

Senior Design Project USRA/NASA/VPI

MAY 1992

PRESSURIZED LUNAR ROVER

ORIGINAL PAGE
COLOR PHOTOGRAPH

N93-18015

Unclas

G3/37 0141624

Kenneth Creel
Jeffrey Frampton
David Honaker
Kerry McClure
Mazyar Zeinali

ADVISORS:

PROFESSOR ANTONY JAKUBOWSKI
DEPARTMENT OF AEROSPACE AND OCEAN ENGINEERING
VIRGINIA POLYTECHNIC INSTITUTE AND STATE UNIVERSITY

DAVY A. HAYNESS
SPACE EXPLORATION INITIATIVE
NASA LANGLEY RESEARCH CENTER

DEPARTMENT OF AEROSPACE AND OCEAN ENGINEERING
VIRGINIA POLYTECHNIC INSTITUTE AND STATE UNIVERSITY

(NASA-CR-192034) PRESSURIZED LUNAR
ROVER (Virginia Polytechnic Inst.
and State Univ.) 106 p

TABLE OF CONTENTS

CONTENTS
PAGE NUMBERS

Abstract	
List of Figures	
List of Tables	
Symbols and Acronyms	
1.0 Introduction	1
1.1 Key Design Requirements	2
1.2 Design Approach	2
1.3 Structural Evolution	3
2.0 Rover Mechanical Systems	6
2.1 Structure	6
2.2 Suspension	10
2.3 Wheels	17
2.4 Steering	18
2.5 Brakes	19
2.6 Motors	20
2.7 Interior	23
2.8 Overall Summary	24
3.0 Power System	26
3.1 System Candidates	29
3.2 PLR Power Supply	33
3.3 Battery Power Supply	40
3.4 Summary	40
4.0 Life Support System	42
4.1 Air Revitalization Module	44
4.2 Water Management Module	54
4.3 Food Provision Module	57
4.4 Waste Disposal Module	58
4.5 Crew Health Module	61
4.6 LSS Summary	62
5.0 Electronic Systems	64
5.1 Communications	64
5.2 Navigation	67
5.3 PLR	70
5.4 Control System	72
6.0 Conclusion	75
References	78
Appendices	82

ABSTRACT

The pressurized lunar rover (PLR) consists of a 7 m long, 3 m diameter cylindrical main vehicle and a trailer which houses the power and heat rejection systems. The main vehicle carries the astronauts, life support systems, navigation and communication systems, directional lighting, cameras, and equipment for exploratory experiments. The PLR shell is constructed of a layered carbon-fiber/foam composite. The rover has six 1.5 m diameter wheels on the main body and two 1.5 m diameter wheels on the trailer. The wheels are constructed of composites and flex to increase traction and shock absorption. The wheels are each attached to a double A-arm aluminium suspension, which allows each wheel 1 m of vertical motion. In conjunction with a 0.75 m ground clearance, the suspension aids the rover in negotiating the uneven lunar terrain. 15 N-m torque brushless electric motors are mounted with harmonic drive units inside each of the wheels. The rover is steered by electrically varying the speeds of the wheels on either side of the rover.

The PLR trailer contains a radioisotope thermoelectric generator providing 6.7 kW. A secondary back-up energy storage system for short-term high-power needs is provided by a bank of batteries. The trailer can be detached to facilitate docking of the main body with the lunar base via an airlock located in the rear of the PLR. The airlock is also used for EVA operation during missions.

Life support is a partly regenerative system with air and hygiene water being recycled. A layer of water inside the composite shell surrounds the command center. The water absorbs any damaging radiation, allowing the command center to be used as a safe haven during solar flares.

Guidance, navigation and control are supplied by a strapdown inertial measurement unit that works with the on-board computer. Star mappers provide periodic error correction. The PLR is capable of voice, video, and data transmission. It is equipped with two 5 W X-band transponders, allowing simultaneous transmission and reception. An S-band transponder is used to communicate with the crew during EVA.

The PLR has a total mass of 6197 kg. It has a nominal speed of 10 km/hr and a top speed of 18 km/hr. The rover is capable of towing 3 metric tons (in addition to the RTG trailer).

LIST OF FIGURES

Figure 2-1	PLR Configuration	7
Figure 2-2	PLR Dimensions	8
Figure 2-3	Composite Cross Section	10
Figure 2-4	Ground Clearance	12
Figure 2-5	Mobility Diagram	14
Figure 2-6	Suspension Diagram	15
Figure 2-7	Wheel Cross Section	15
Figure 2-8	Gear Reduction System	22
Figure 2-9	Interior Layout	25
Figure 2-10	Interior Cross Sections	25
Figure 3-1	Soil Gathering Mission	28
Figure 3-2	Optical Interferometer Mission	29
Figure 3-3	RTG Dimensions	35
Figure 3-4	Power Distribution	37
Figure 3-5	Wiring Position	39
Figure 3-6	Battery Housing	39
Figure 4-1	Life Support	43
Figure 4-2	Humidity Control	43
Figure 4-3	Ceiling Layout	45
Figure 4-4	Thermal Bus	45
Figure 4-5	Heat Exchanger	47
Figure 4-6	Underfloor Layout	53
Figure 4-7	Mass Requirements	53
Figure 4-8	Cross Section	56
Figure 4-9	Bed Layout	56
Figure 4-10	Water Management Diagram	57
Figure 4-11	Trash Compactor	59
Figure 4-12	Toilet	59
Figure 5-1	Earth-Moon Communications	66
Figure 5-2	Communications System	66
Figure 5-3	Underfloor Electronics Layout	69
Figure 5-4	Navigation System	69
Figure 5-5	Camera Placement	71
Figure 5-6	Computer System	71
Figure 5-7	Ceiling Computer Layout	73
Figure 5-8	Control System	73

LIST OF TABLES

Table 2-1	Suspension Mass	17
Table 2-2	Motor Requirements	20
Table 2-3	Motor Candidates	21
Table 2-4	Mechanical Systems Mass	24
Table 3-1	Optical Interferometer Installation	27
Table 3-2	Soil Gathering Mission	28
Table 3-3	Array Parameters	30
Table 3-4	DIPS Parameters	31
Table 3-5	RTG Parameters	33
Table 3-6	Battery Specifications	40
Table 3-7	Power System Mass Summary	41
Table 4-1	Design Loads	42
Table 4-2	Mass and Power Totals	63
Table 5-1	Electronics System Parameters	74

ACRONYMS

ARM-Air Revitalization Module
CC-Charcoal Canister
CL-Camera/Light
CHM-Crew Health Module
EVA-Extra Vehicular Activity
F-Filter for WMM
FA-Fire Alarm
FE-Fire Extinguisher
FPM-Food Provision Module
GN&C-Guidance Navigation and Control
IR-Iodine Remover
IMU-Inertial Measurement Unit
IS-Iodine Supplies
LOH-Lithium Hydroxide Canister
LSS-Life Support System
MLI-Multilayered Insulation
MMB-Multi-Media Bed
PLR-Pressurized Lunar Rover
PWS-Potable Water Storage
RTG-Radioisotope Thermal Generator
TCC-Treated Charcoal Canister
TCCS-Trace Contaminant Control System
TRANS-Transponder
UST-Urinal Storage Tank
WDM-Waste Disposal Module
WMM-Waste Management Module

1.0 INTRODUCTION

As the space program develops, it will become necessary to establish and maintain a lunar base. This base will provide a foothold on the moon, from which further exploration and expansion into space can take place. The space program will involve many endeavors on the moon. Various lunar tasks require a dependable means of transportation. Some of these missions will be in the immediate vicinity of the base and require only a short time to complete. These can be performed by crew using EVA suits and a primitive unpressurized lunar rover. Other missions will involve much longer times and larger distances. These missions require a pressurized lunar rover (PLR). The PLR must provide both shelter for the crew and the equipment to perform a large variety of tasks. In essence, it must be a mobile home for the lunar workers. The rover must be versatile, flexible, and dependable.

The first lunar rover was brought to the moon during the Apollo missions. The vehicle was a crude method of transportation, serving as little more than a go-cart for the astronauts. In the intervening years since the Apollo missions, many methods of lunar surface transportation have been suggested. The next lunar rovers must be rugged and dependable, yet comfortable and safe for the crew.

Recognizing the importance of the PLR to the future of the space program, NASA Langley has suggested a pressurized lunar rover as a senior design project. The main objective is to design a PLR that will effectively serve the needs of the crew and the

lunar residents. NASA has established the following important design parameters for this project.

1.1 KEY DESIGN REQUIREMENTS

1. PLR shall have a nominal operational radius of 500 km (1,000 km range) per mission (lunar day).
2. PLR shall have a nominal operational radius of 50 km (100 km range) for lunar night operations.
3. PLR shall be able to support a nominal crew of four (4).
4. PLR shall have a nominal operational time of 14 days per mission.
5. PLR shall have an airlock to allow EVA and which is compatible with the lunar surface habitat.
6. PLR shall have an emergency one-time range of 2,000 km with a crew of two (2).
7. PLR shall be able to support a crew of six (6) in an emergency with no range requirement (lunar surface safe-haven).
8. PLR shall have storage and consumable provisions to support two (2) EVA suits for 28 hours of use each per mission.
9. PLR shall have a direct communications capability with the Earth (audio, visual, and data).
10. PLR shall be able to tow utility trailers with a mass of up to 2 metric tons.
11. PLR shall have a nominal operational speed of 10 km/hr.

1.2 DESIGN APPROACH

A design philosophy is imposed upon this project by the very nature of the moon. The moon allows no margin of error, and its unforgiving environment punishes mechanical systems. This demands that any system destined for lunar use be impervious to

failure. By keeping the PLR as simple as possible, its weaknesses can be limited.

Since the PLR must be shipped to the moon, it is imperative that its weight be kept to a minimum. Any system's added weight must justify its shipping costs with increased utility. Complex systems are avoided. They not only invite failure, but also add weight to the PLR. Simplicity is the driving principle behind the design of the rover. This simplicity facilitates obtaining the other design goals of reliability and minimum weight.

1.3 CONFIGURATION EVOLUTION

1.3.1 Shell

The most important structural criteria for the rover are high strength, low weight, efficient use of interior space, and simplicity. Spherical, elliptical, rectangular and circular cylinder shell shapes were considered. Although the spherical shape has the best volume to surface area ratio, it would of been very large and unwieldy because of its shape and was thus unsuitable for use. The elliptical shapes were eliminated based on the complexity of construction and extra weight. The rectangular box type shapes would involve stress concentrations at the corners of the structure, requiring a disproportionate weight for the volume obtained. The circular cylinder is the best choice for the shape of the rover because it offered good interior space, low weight, and simplicity. The shell will be made of a multi-layer composite construction. The shell will be

capped by faceted ends constructed of the same composite material.

1.3.2 Suspension

The suspension must provide good mobility, redundancy, simplicity, low weight, and durability. A-arm, trailing arm, solid axle and rigid type suspensions were examined for use on the PLR. A rigid suspension does not provide ample shock absorption during negotiation of rough terrain. The rigid axle suspension prevents independent wheel motion, and severely limits ground clearance. Trailing arm suspensions do not have adequate lateral stiffness for the loads imposed by driving on the moon. The A-arm type was chosen because it offered the greatest ground clearance, an important asset when negotiating the lunar surface. It is very simple, and allows for good mobility (each wheel moves independently).

1.3.3 Drivetrain

Normal multiple wheels, tracks and wheel track combinations were examined. The tracks were ruled out due to their weight and complexity. Six wheels is the optimal configuration for negotiating difficult terrain (Ref. 1). Four-wheeled vehicles can easily become stuck in ruts. Six wheels provide three points of contact along the transverse axis of the PLR, thus increasing mobility. More than six wheels add little advantage, while increasing weight and complexity. Motors could be mounted on the rover body or in the wheels themselves. The latter was chosen since the need for a transmission is eliminated.

1.3.4 Overall Configuration

The PLR will tow a two-wheeled trailer which contains the rover's power supply in the form of an RTG. The placement of the RTG in the trailer has a number of advantages. The amount of shielding needed is considerably less than if the RTG were contained in the main body of the rover. The use of interior space and the weight distribution in the body is significantly improved. The trailer can be detached for safety and docking purposes. The rear cap of the rover will contain the airlock which is used for both EVA and docking purposes.

2.0 ROVER MECHANICAL SYSTEMS

2.1 STRUCTURE

The first step in the design of the PLR was to decide on a shape and basic configuration that would meet the requirements. Since the rover must be pressurized, the shape of the crew compartment is critical. To keep stress concentrations from the pressurization to a minimum, a cylindrical shape was chosen. The cylinder is capped by eight-section, faceted, semi-hemispherical ends. True hemi-spherical ends pose problems with the placement of windows and airlocks, leading to the use of faceted ends. The faceted ends provide flat surfaces for the windows and airlock, while keeping stresses to a minimum. The basic configuration is shown in Figure 2.1. The PLR is shown with a trailer in tow. The trailer contains the RTG power source and is not pressurized. The cylindrical shape of the trailer is simply a dust shield for the RTG. Top, side and front views of the complete configuration with dimensions are shown in Figure 2.2.

Various materials were researched for use in the construction of the PLR shell. Aluminum alloys, titanium, steel, and composites were examined. The metals were strong, but also heavy. Weight was the most important factor in the materials selection. Of all the materials, the composites had the best properties for this application. The composites are light weight and have very high strength. The choice of the actual composite material is a complicated procedure. Because the composite materials are not isotropic, simple stress formulas can only

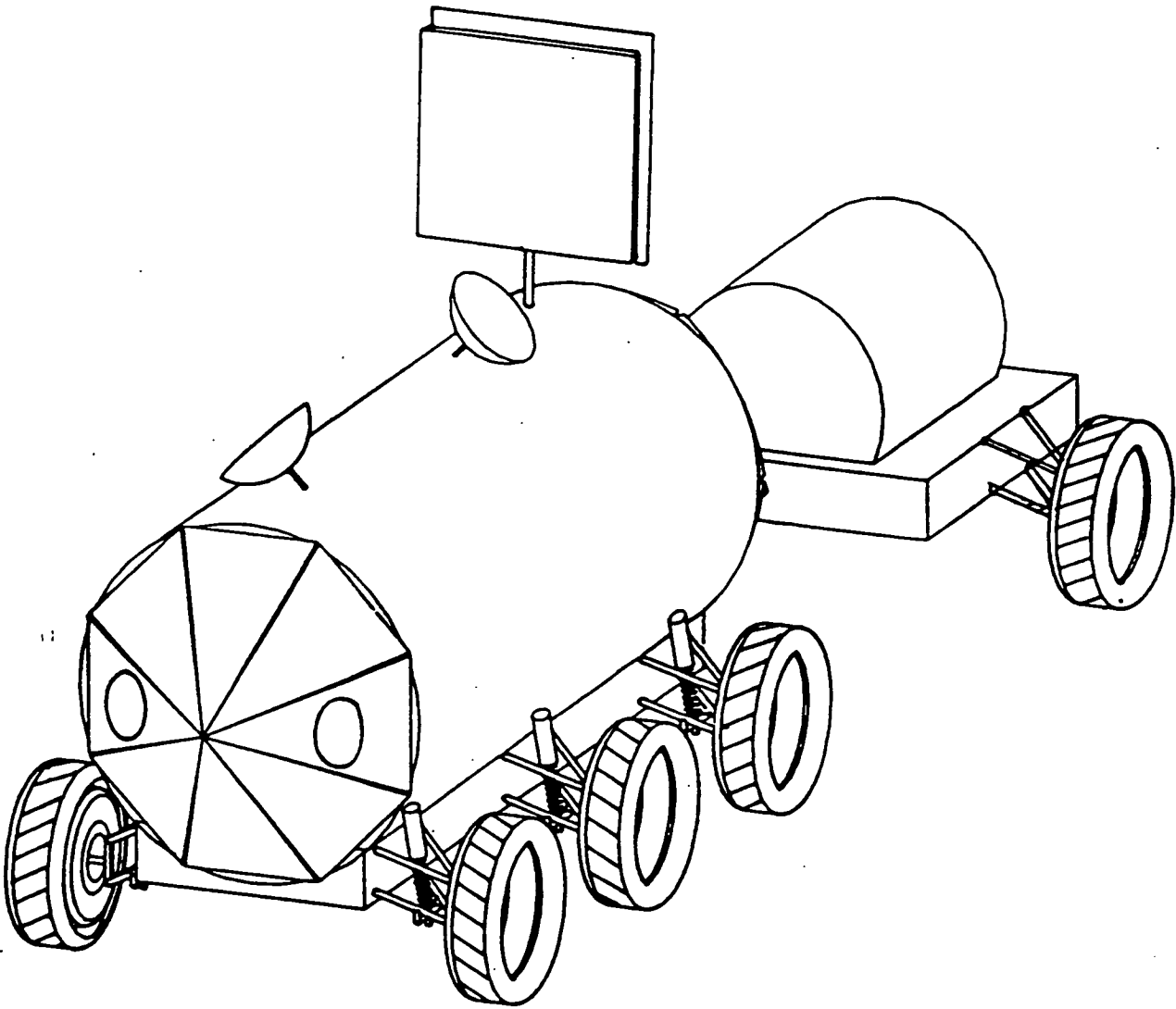

FIGURE 2-1
PLR configuration

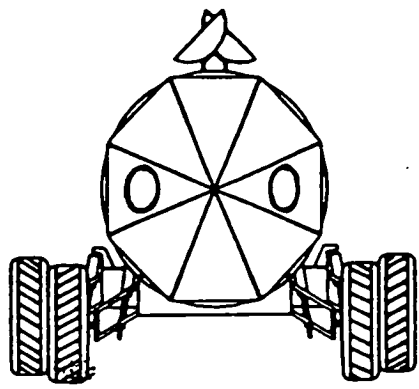
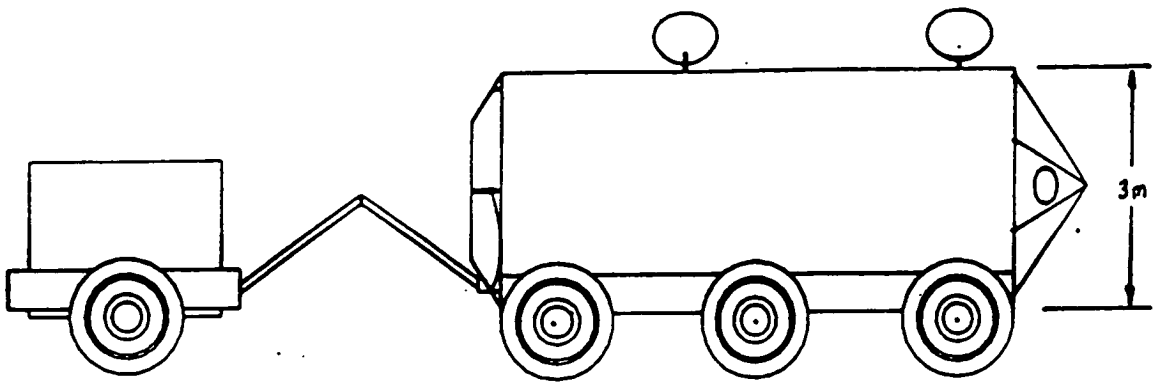
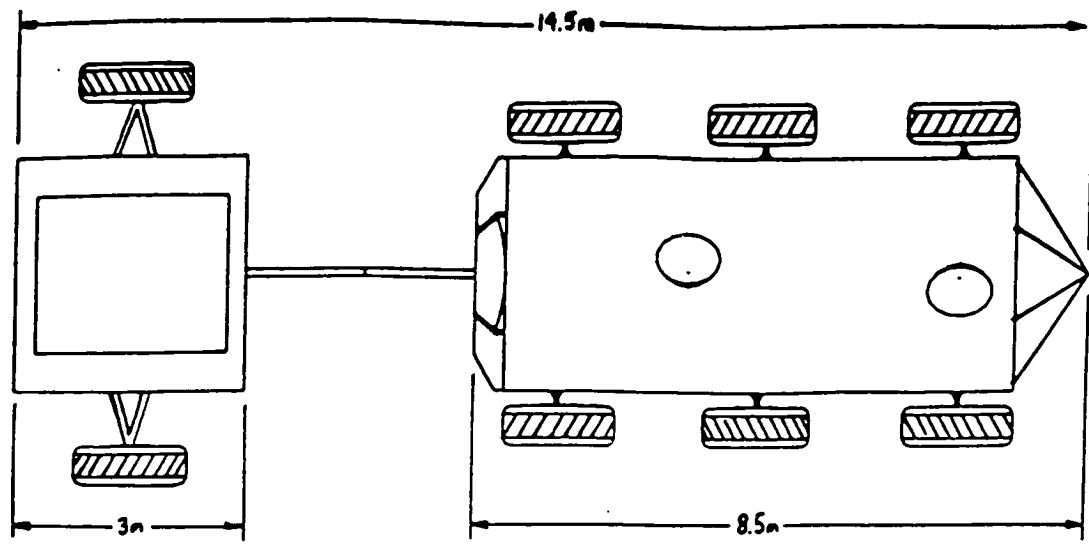
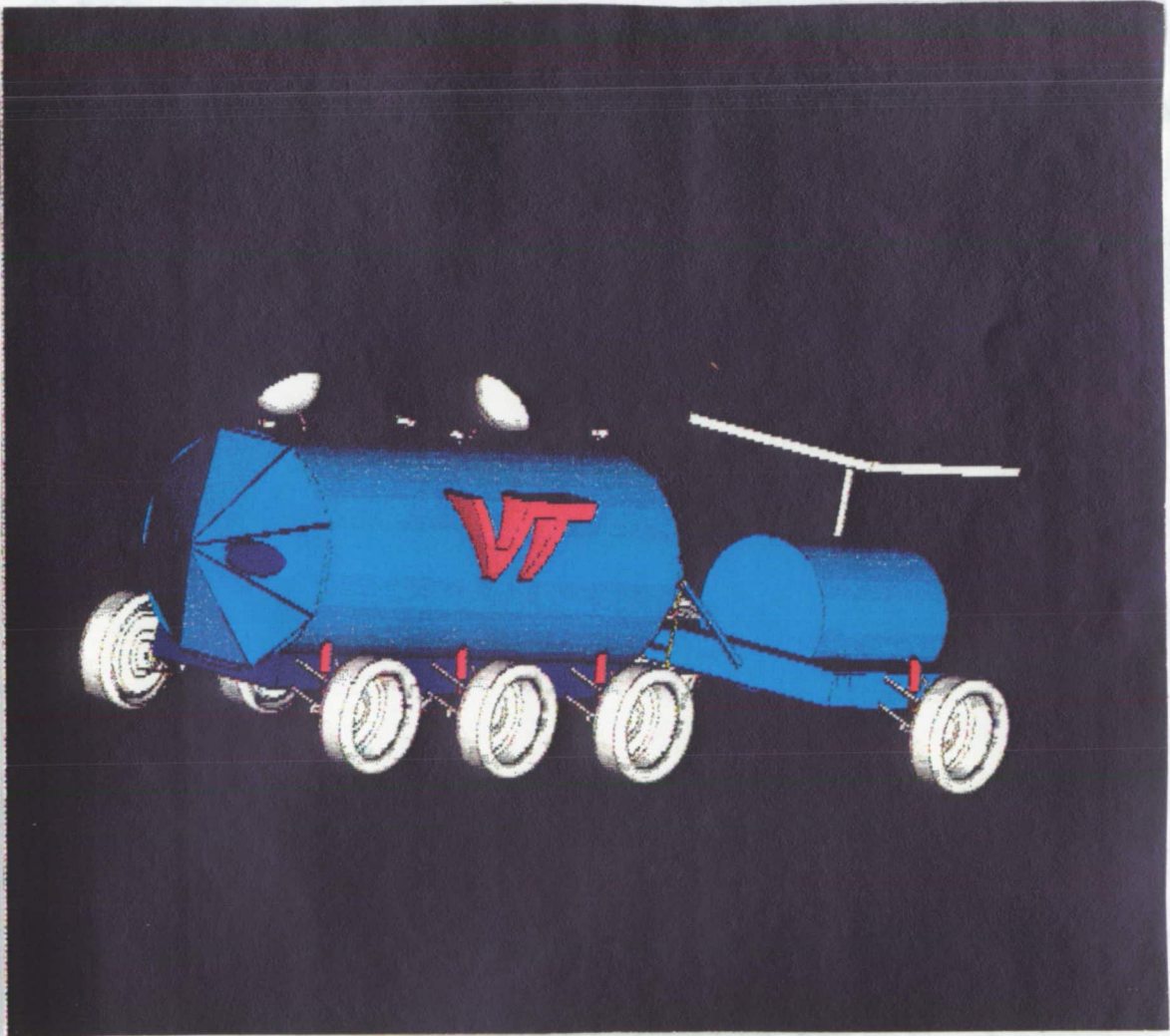

FIGURE 2-2
PLR dimensions

ORIGINAL PAGE
COLOR PHOTOGRAPH



yield rough approximations of the required amount and material type, therefore Chuck Chandler, a composites specialist, was consulted. (Ref. 1) It was recommended that a Carbon Fiber/Foam/Kevlar sandwich structure would be an excellent choice for the PLR shell. The shell would be composed of these materials in layers as shown in Figure 2.3. Included in the shell structure is a layer of water for radiation protection. The layer of water extends from the front of the rover over the crew compartment and creates a safe haven for the crew during a solar flare-up. The carbon fiber provides the majority of the strength and stiffness in the structure and the Kevlar provides protection from micrometeoroids. Both the carbon fiber and the kevlar layers would be made up of several plies of the material oriented in 0°, 45°, and 90° directions to obtain omni-directional strength. The foam between the layers provides both strength and protection. It helps absorb and spread out the force from the impact of a micrometeoroid and also helps insulate the rover. The Kevlar is coated with a layer of gold foil and MLI to reduce radiation degradation and heat transfer through the wall. The carbon fiber layers are coated with a thin thermo-plastic layer to completely seal the fiber and also provide structural strength. The actual composite thicknesses shown were recommendations from Chandler. A detailed finite element computer analysis must be done before a complete and final selection of specific material thickness can be determined. The mass for the composite shell will be 500 kg and it will be 8.5m long and 3m in diameter.

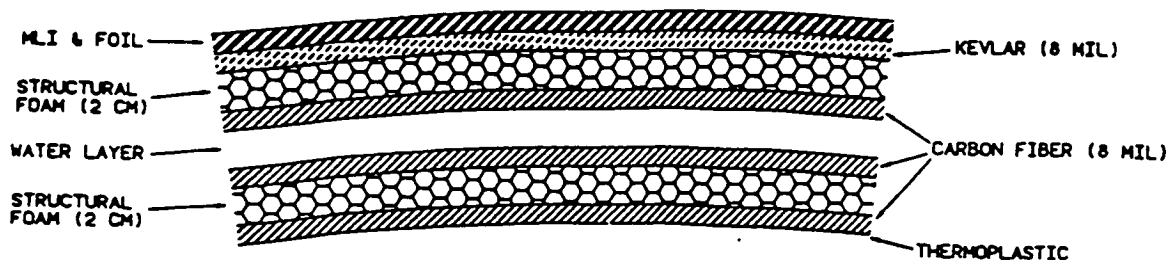

FIGURE 2-3
Composite Cross Section

2.2 SUSPENSION

The mobility of the rover is a major factor because of the moon's rough terrain. Suspension requirements included high ground clearance, reliability, stability and provisions for redundancy. The suspension must allow the PLR to move across the lunar surface with relative ease.

Trailing arm, rigid axle and double A-arms suspension systems were examined. The trailing arm and rigid-axle systems were rejected because of the lack of ground clearance, reduced wheel travel and weight. Specifically, the trailing arm suspension would require a larger cradle under the PLR's shell to obtain the wide wheelbase needed for stability. This larger cradle would increase the PLR's weight. The rigid axle suspension would allow for ground clearance of less than half the wheels height. This would prevent the PLR from moving over many obstacles. The rigid axle suspension would also have limited

wheel travel and the wheels would not move totally independent of each other. A double A-arm suspension was chosen because it satisfies the requirements very well. With this suspension, the ground clearance of the PLR is more than 0.85 meters. Thus the rover can drive over large rocks without changing the position of the crew compartment. The ground clearance is illustrated in Figure 2.4. The A-arm suspension also allows the wheels to move independently of each other. This property combined with the ground clearance allows the PLR to maneuver over hills and valleys while keeping the movement of the crew compartment to a minimum. This is illustrated in Figure 2.5. An isometric view of the suspension of one wheel is shown in Figure 2.6. The A-arms are of equal length and are parallel when viewed from the front or back. They are connected to the PLR with simple pivot joints that allow for up and down motion only. They are also connected to the kingpin by the same kind of joints. The kingpin is the vertical member closest to the wheel from which the motor shaft extends. The A-arm shape allows for the placement of the shock inside of the arms. The lower part of the shock is attached to the middle of the lower A-arm and the upper part to the PLR shell. As the wheel moves over a bump, the shock is compressed as the A-arms pivot. The wheel remains vertical as it is displaced up or down and there is very little motion of the wheel in the horizontal direction due to the length of the A-arms. This prevents the wheels from rubbing in and out and reduces friction when the wheel is displaced up or down. The A-arms and the kingpin are

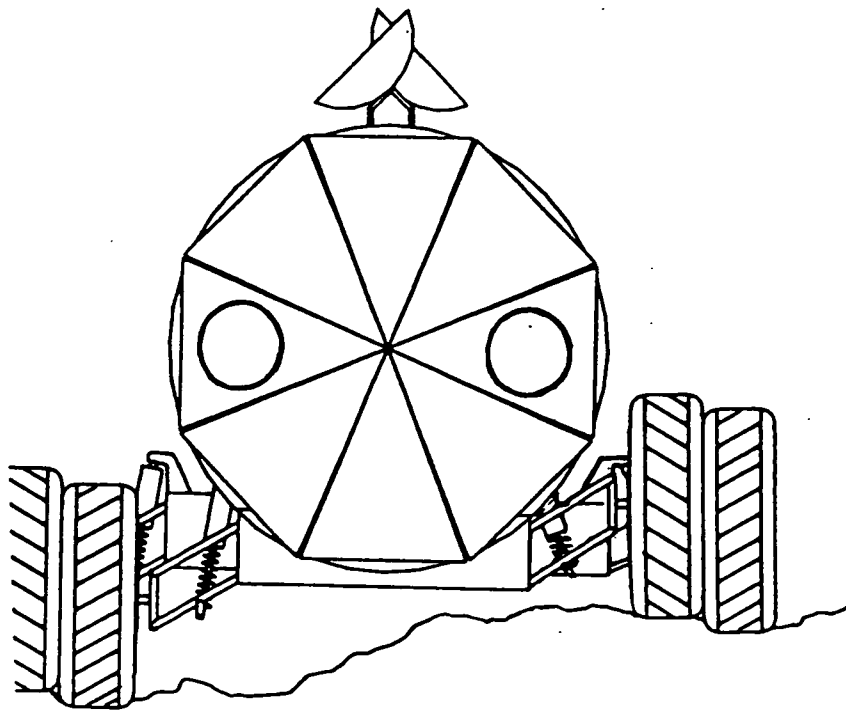
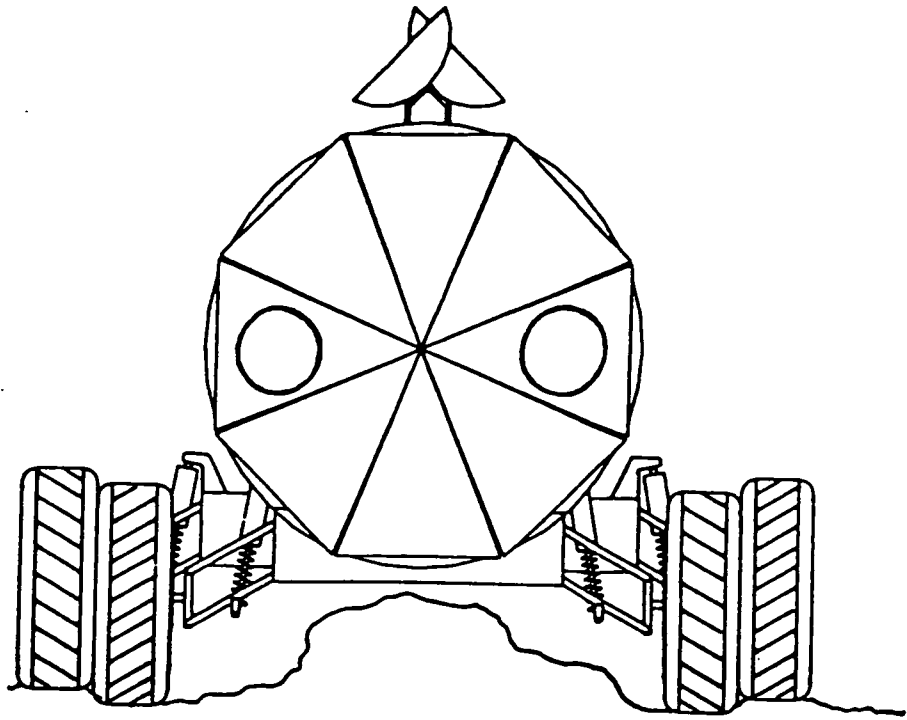

FIGURE 2-4
Ground Clearance

made of aluminum 2014-T6 series alloy. The A-arms are made from thin-walled tubing 5 cm in diameter. The kingpin is made from aluminum and the shaft for the wheel is made from steel. This type of suspension provides for great mobility because each wheel moves independently of the others which allows the rover to ride over a rough surface and large obstacles. The wheels can remain in contact with the surface, minimizing traction loss. Each individual wheel can travel up and down one meter and thus would be able to clear most obstacles. The shock that would be used as shown would be of the spring/damper type. The addition of a fully active suspension would improve the mobility even further, although this gain is not justified by the added weight and complexity. The chosen design provides effective performance with minimal mechanical complexity, thus minimizing the chance of a suspension failure.

The number of wheels on the PLR was determined by the mass and mobility characteristics. Based on the carrying capacity of each wheel, the mass of the PLR requires that there be at least six wheels to share the load. Terramechanics references showed that the best possible configuration for an off-road vehicle like the PLR was to also have six wheels. (Ref. 2) The dimensions and weights of the suspension parts per set are listed in Table 2.1.

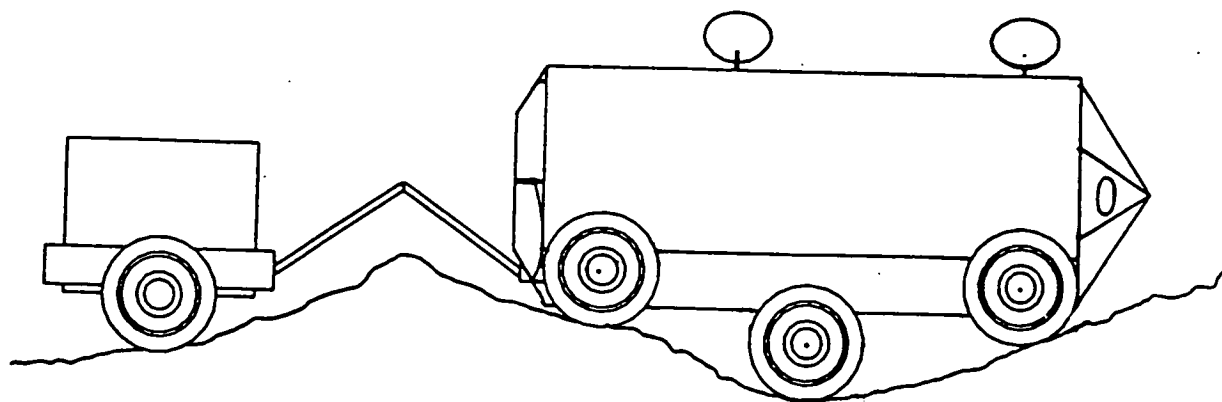
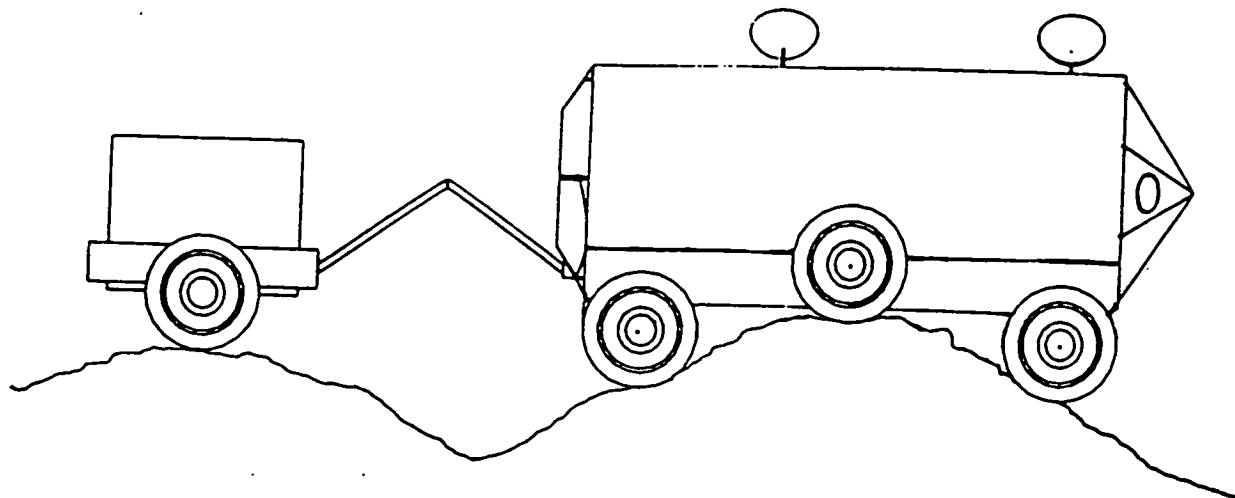

FIGURE 2-5
Mobility Diagram

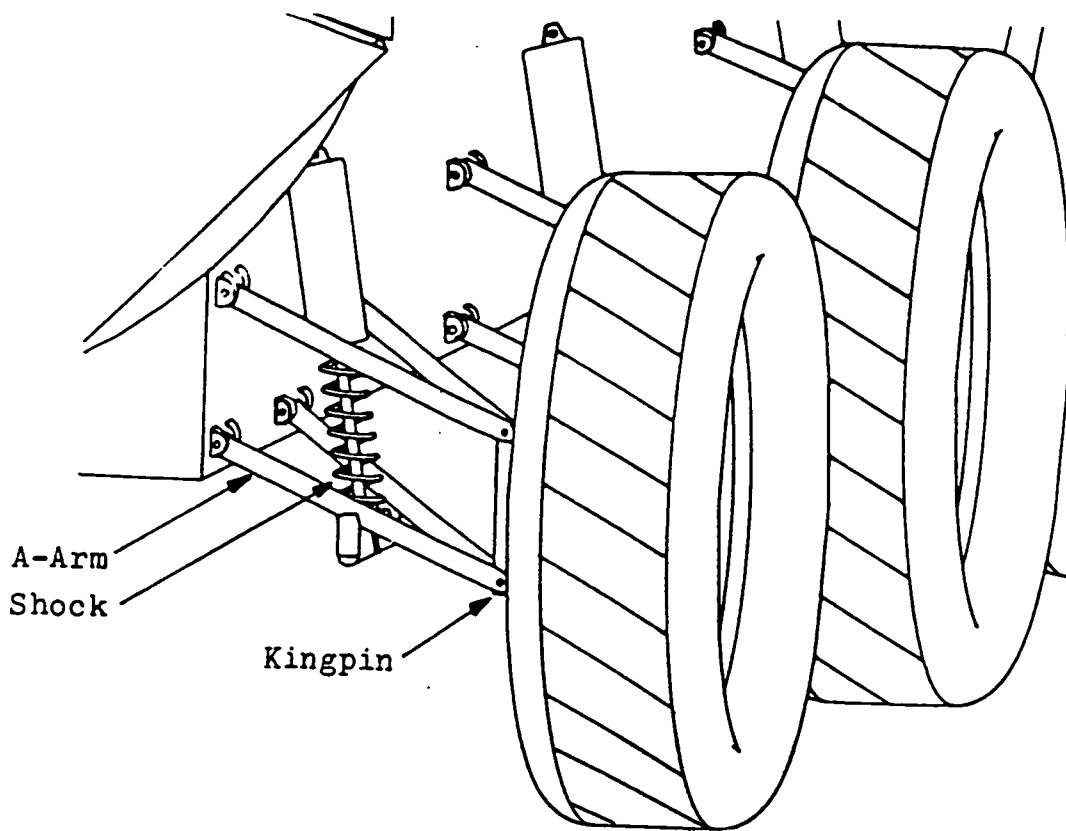

FIGURE 2-6
Suspension Diagram

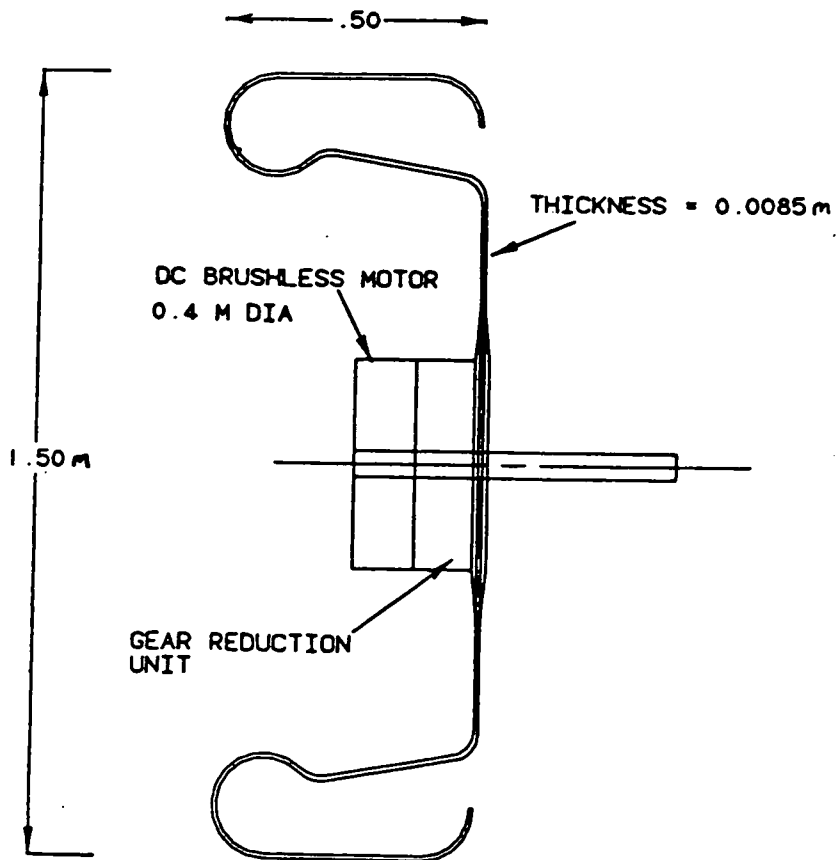

FIGURE 2-7
Wheel Cross Section

TABLE 2.1: Suspension mass

	Length	Width	Diameter	Thickness	Mass
A-Arms	0.8 m	0.4 m	0.05 m	0.002 m	10 kg
Shock		--	0.08 m	--	7 kg
Kingpin	0.4 m		0.05 m	solid	5 kg
TOTAL PER SET					22 kg

2.3 WHEELS

The wheel should be light, flexible, and capable of handling both rocky and sandy terrain. The wheel that was used on the Apollo missions lunar rover was used as a nucleus for the PLR wheel design. The wheel shown in Figure 2.6 was created from a collection of sketches and ideas. The wheel's unique design is made possible through the use of a composite flexible plastic matrix that is both light and strong. The wheel has 150 radial slots in the outer surface that allow it to flex under the vehicle weight. This flexing action absorbs some of the surface irregularities and also creates a surface intelligent contact patch. On a rough or soft surface, the tire will flex to create a larger contact patch that will improve traction and prevent sinkage. On harder surfaces where not as much traction is required, the contact patch will not be as large and thus friction will be reduced. The tire's contact area provides traction and prevents the PLR from sinking too deeply into the lunar soil. The size of the tires was determined by calculating the amount of sinkage allowed and the contact area required. For a sinkage of approximately 5 cm, the tire has a radius of 1.5 m

and a width of .5 m. To keep the lunar dust from accumulating in the wheel and to protect the motor and gear drive, the wheel has coverings on both the inside and outside. These coverings are made from a flexible and light material. The wheels also have cleats around the outside to aid in traction on softer lunar soil. These cleats are shaped so as to aid in traction in the forward and reverse motion of the PLR but also minimize friction when the PLR engages in a turn.

The drive motors will be placed inside of the wheels as shown in Figure 2.7. By placing the motors in the wheels, the need for a complicated transmission is eliminated, reducing the weight of the system. This design also provides built in redundancy. In the case of one or two motor failures, the remaining four to five motors could return the rover to the lunar base for repairs.

2.4 STEERING

The steering of the rover could be accomplished by several means. A mechanical steering system where two or more wheels would turn could be used or a total electrical system where the speeds of the motors on opposite sides of the rover would be varied could be employed. The electrical system is simpler than the mechanical system. It requires only electronic controllers for each wheel and a central controlling computer to steer the PLR. Calculations show that there would be sufficient power from the motors to overcome the friction imparted on the wheels as they dragged during a turn (Appendix 2.1). Each wheel needs to

supply a torque of 521 Nm to turn the PLR within its own length with zero forward velocity. This is a conservative estimate but the torque required was still less than 800 Nm which can be supplied if needed. If the crew desires to make a gradual turn to the right or left, the motors on the opposite side simply turn at a faster rate to accomplish the direction change. For tighter turns, the motors on one side turn faster and the motors on the opposite side are slowed down. This type of steering is similar to that used by tanks and bulldozers. The rover can theoretically turn around within its own length. On softer lunar soil, the wheels rounded cross-sectional shape prevents them from digging into the soil as they are dragged sideways. They should be able to float on top of the soil minimizing friction during a turn. On the harder lunar soils, the tires will sit up on the cleats and the friction will be low allowing the PLR to turn easily.

2.5 BRAKES

Since electric motors that have the ability to reverse their torque were chosen for the drive system, the need for a mechanical breaking system is eliminated. To slow or stop the PLR, the motors are used as generators. By varying the current and voltage across the motor, the PLR is slowed or stopped while the batteries are charged. There is no need for any added mechanical systems to assist in braking which it turn would add weight to the PLR.

2.6 MOTORS

This section of the PLR mechanical system deals with the selection of motors and motor controllers. The performance capabilities of the vehicle with the selected motor and controller is analyzed in detail to insure they are able to perform in the harsh lunar environment.

2.6.1 Motor Selection Criteria

The criteria set by NASA dictated that the rover must have a nominal speed of 10 km/hr, be capable of towing 2 metric tons of cargo, and have the ability to traverse the harsh lunar surface. However, other requirements were developed in conjunction with other subsystems of the rover. These requirements are listed in Table 2.2 below:

TABLE 2.2: Motor Requirements

1. 10 km/hr nominal speed
2. Maximum torque of 831.1 N-m
3. Maximum power of 3.08 kw
4. Maximum input voltage of 300 V
5. Maximum input current of 20 A
6. Long life
7. Low weight

2.6.2 Motor Candidates and Selection

Two general types of motors are considered for the PLR, DC brushless and DC brush. Through the research of existing literature, including manuals supplied by Inland Motors Corporation(Ref. 3), Globe Motors(Ref. 4), Inertial Motors Corp.(Ref. 5), and Industrial Drives(Ref. 6), brushless motors turn out to be the best choice for lunar applications. Brushless motors are superior under heat stress because the magnets are not in contact with the windings and the operational life is slightly longer than that of the brush design. Using the criteria previously identified, six candidate motors, all manufactured by Inland Motors, were chosen. This company was chosen because Inland Motors designs high performance motors for rigorous environments whereas the other companies manufacture motors for commercial applications. The motor candidates are listed in Table 2.3 below:

TABLE 2.3: Motor Candidates

1. BMS-7101
2. BMS-7401
3. BMS-11801
4. BMS-12901
5. RBE-04502-B50
6. RBE-06202-B50

After initial calculations the BMS-7101, BMS-7401, BMS-11801, and RBE-04502-B50 motors were eliminated. The BMS-7101, BMS-7401, and the BMS-04502-B50 do not have the continuous operating capabilities to supply the 10 km/hr nominal speed required by

NASA. The BMS-11801 is not acceptable due to its extreme mass. The remaining two motors are investigated in detail in Appendices 2-2 and 2-3.

The deciding factor in choosing the motor was the motor mass and size. The mass of the BMS-12901 is 72.55 kg while the mass of the RBE-06202-B50 is 20.40 kg. The unhoused BMS-12901, this motor comes without a specifically designed housing, has a diameter of 62.23 cm and a depth of 10.67 cm while the housed RBE-06202-B50 has a diameter of 25.72 cm and a depth of 11.56 cm. Thus, since each motor is fully capable performing the functions needed, the RBE-06202-B50 was chosen because of its smaller mass and dimensions. Specifications for the selected motor are provided in Appendix 2-4. Fig. 2.8 shows the schematic for the gear reduction system used to provide the torque required for the RBE-06202-B50 motor. Each of the large gears multiplies the torque output of the motors by a factor of 5.57 to step up the torque to the output needed for various inclines. The gear system will add another 10 kg per wheel.

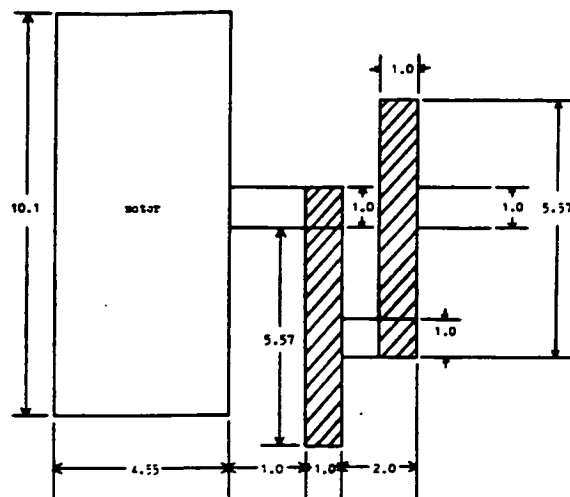

Figure 2.8 Gear Reduction System

2.6.3 MOTOR CONTROLLER SELECTION

The only criteria for the servo amplifier is that it be able to output a maximum of 300 V and 30 A. These criteria are satisfied by the BLR-9000 Servo Amplifier manufactured by Inland Motors. This motor controller has a mass of 11.34 kg and is over 90% efficient. The specifications for this servo amplifier are shown in Appendix 2-5.

2.6.4 MOTOR SUMMARY

The drivetrain will consist of six model RBE-06202-B50 Motors and six model BLR-9000 Servo Amplifiers. The total mass for the motors is 122.4 kg and the total mass for the amplifiers is 68.04 kg. To keep the motor temperature within the acceptable 155°C cooling water is pumped over the motor housing to dissipate heat during strenuous operating conditions. The motors will also have encapsulated windings, manufactured by Inland Motors, to prevent the lunar dust from being trapped in the windings and causing the motor to malfunction.

2.7 INTERIOR

The interior layout of the PLR is shown in Figure 2.9. The command center from where the PLR is controlled by the crew is located in the front two meters. The command center is also used as a safe haven for the crew in case there is a solar flare warning. The exterior shell is shielded with the layer of water explained earlier and the interior is separated by a aluminum divider. When there is no danger, the aluminum divider is kept open to create more space. Immediately behind the command center

is the lab area on the right and the first pair of bunks on the left. This area is two meters in length. The next section contains the galley on the right and storage on the left. The bathroom is adjacent to the galley on the right. The rearmost portion of the PLR is where the airlock and the last two bunks are located.

The layout lacks dividers between sections, providing an open space throughout the length of the PLR that creates a feeling of spaciousness. When not in use, the two upper bunks can be folded down to create two couches for the crew to relax or eat on. The bottom bunk serves as the seat and the top serves as the back of the couch. The bunks can also be used for storage space when the crew is not occupying them. Cross sectional views of the interior are presented in Figure 2.10.

2.8 SUMMARY

The complete structure and mechanical system mass is shown in the Table 2.6.

TABLE 2.6: Suspension Mass Summary

Complete Shell	500 kg
6 A-arm sets	60 kg
6 Shocks	42 kg
6 Wheels	240 kg
6 Motors	122 kg
6 Gear units	60 kg
6 Controllers	66 kg
TOTAL MASS	1090 kg

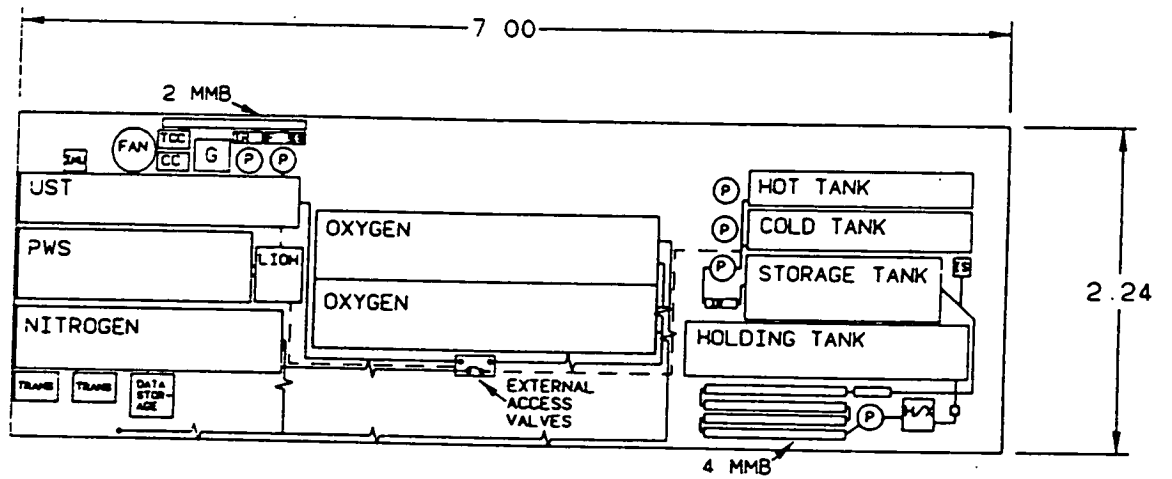
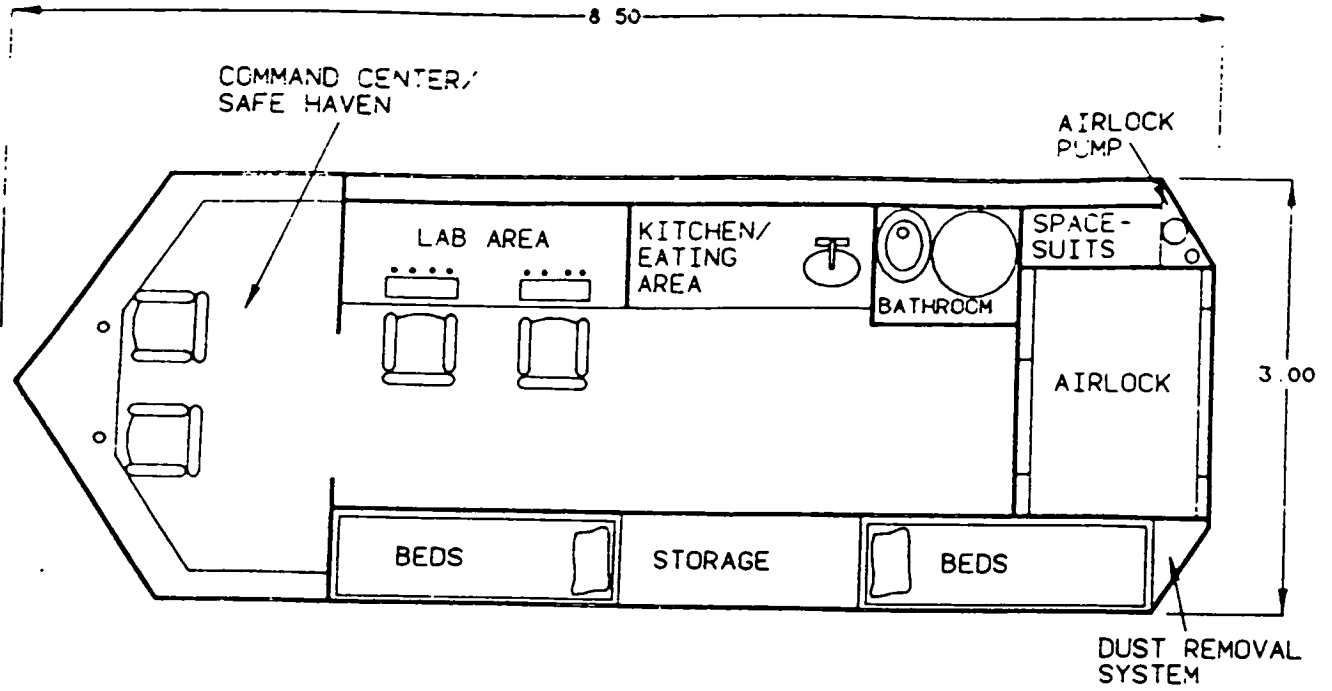

FIGURE 2-9
Interior Layout

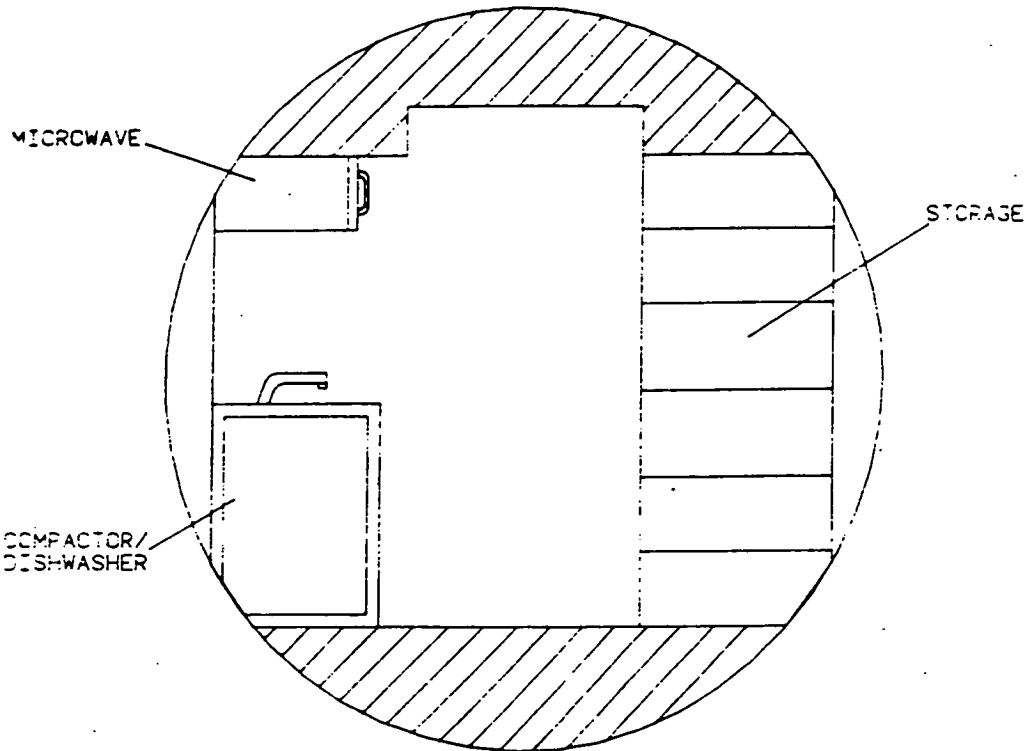
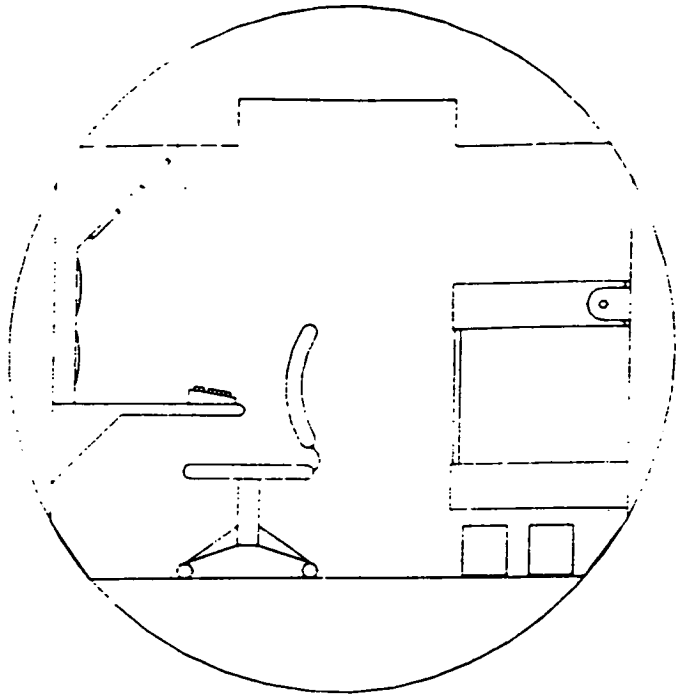

FIGURE 2-10
Interior Cross Sections

3.0 POWER SYSTEM

The power system of the PLR will:

- a) Support a 500 km operations radius
- b) Provide auxiliary emergency power
- c) Support a 50 km radius lunar night operations
- d) Provide power for life support and communications

The power system will supply power to four major systems. These areas and the respective required power are listed below.

Life Support	1.5 kW
Communications/Controls/lights	1.0 kW
Drive System	4.5 kW ave. / 8 kW max
Battery Charging	0.2 kW

The average power requirement is derived by examining some possible PLR missions. Two such missions are optical interferometer installation (long duration, 12 days) and soil sample mission (short duration, 1 day). Mission tasks are listed in Tables 3.2.1a and 3.2.1b respectively.

Using the mission tasks, a power distribution for the soil gathering mission is constructed Figure 3.2.2a. For the optical interferometer mission, a typical 3 day power profile is plotted which represents the 12 day power use (Fig 3.3.2b).

Drive time consists of negotiating varying terrain up to 30 degree inclinations and accounts for different power requirement while driving. Nominal power is derived by adding 200 watts to average power for battery charging (calculations in Appendix 3.1).

Table 3.2.1a

Optical Interferometer Installation*

-
- tow 2 metric tons a total distance of 300 km @ 10 km/hr
 - day -- 15 hr drive (4.5 kw average, 8 kw peak)
9 hr rest
 - day -- 15 hr drive (4.5 kw average, 8 kw peak)
9 hr rest
 - install 6 interferometer units/day assisted by robotic arm for 6 days
 - day 3-8 -- install iterferometer units (1 kw /day)
 - check and test installation 2 days
 - day 9-10 -- testing (1kw/day)
 - return to base
 - day 11 -- 15 hr drive (4.5 kw average, 8 kw peak)
9 hr rest
 - day 12 -- 15 hr drive (4.5 kw average, 8 kw peak)
arrive at base

*Life support is assumed to be in operation at all times and not listed in the above table. Therefore an additional 1.5 kW must be added to each day for the total daily power need.

The drive time power usage for the soil sample mission is assumed to be the same as the interferometer installation mission.

Table 3.2.1b
Soil Gathering Mission

day 1
7 hrs drive (reach destination)
4 hrs gather soil samples
3 hrs rest/eat
7 hrs drive (return to base)

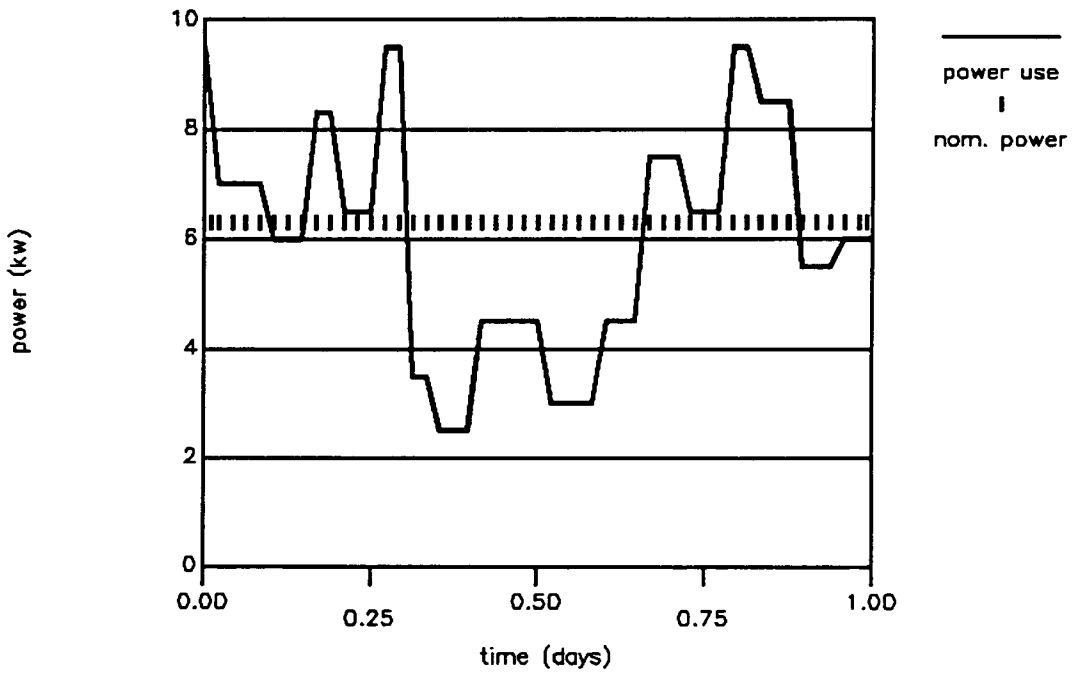

Soil gathering mission
Figure 3.2.2a

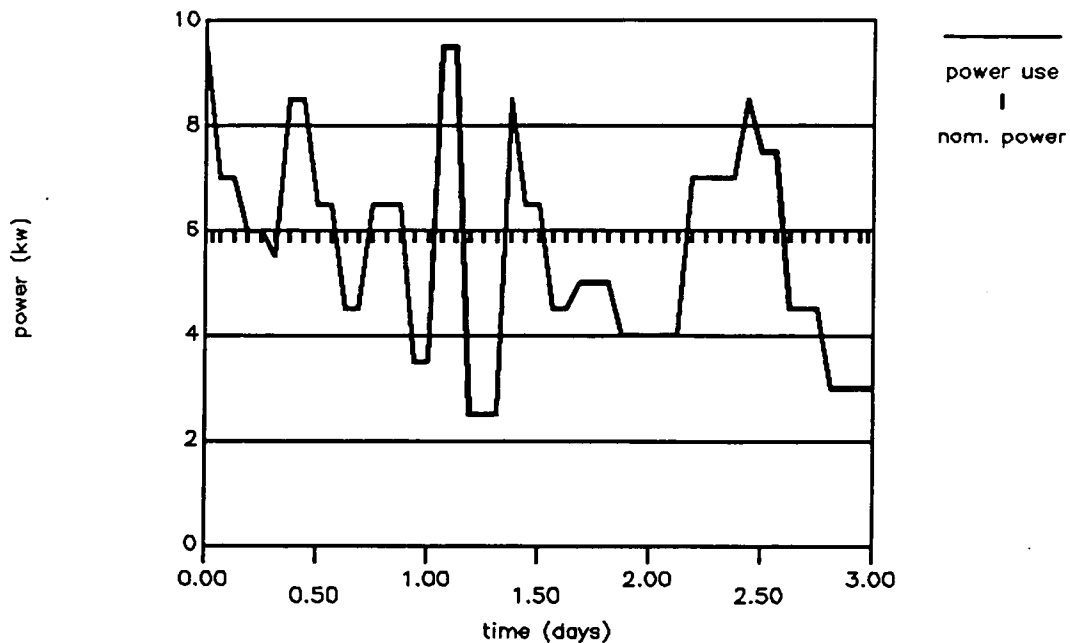

Optical interferometer mission
Figure 3.2.2b

We can see from Figures 3.2.a & b that the PLR nominal power is 6.7 kw and the peak power is 9.5 kw. The nominal power is used in system candidate design and the peak power for secondary system design (Section 3.5).

3.1 SYSTEM CANDIDATES

Three systems were considered to meet the PLR power requirements. They are: Photovoltaic, Dynamic Isotope power system(DIPS), and Modular Radioisotope Thermoelectric Generator(RTG).

3.1.1 Photovoltaic

This system consists of a solar array for normal power requirements and batteries for peak and emergency power use. Two types of photovoltaic cells are considered for this system: amorphous silicon (a-Si), and gallium arsenide (GaAs). Table 3.3.1 summarizes the array parameters. The calculations are based on an average solar intensity of 1.37 kW/m².

TABLE 3.3.1
ARRAY PARAMETERS (Ref. 11, 12)

Cell type	a-Si	GaAs
Cell efficiency	9.2 %	17.5 %
Array efficiency	7.0 %	14.0 %
Power output	6.7 kW	6.7 kW
Array area	73.6 m ²	37 m ²
Specific power	10 We/kg	15 We/kg
Array mass	670 kg	447 kg

Although it is relatively light, Table 3.3.1 shows that an a-Si solar array would not be feasible because of the large array size needed to supply nominal power.

The attributes of the GaAs photovoltaic system are its light weight and feasible array size. Although these are desirable features, this system was rejected for the PLR primary power source. The photovoltaic system requires an alternate power supply for lunar night operations which will add significant mass to the PLR. For a 36 hour lunar night operation, the PLR

requires an additional 804 kg of batteries (Appendix 3.2). Therefore, a photovoltaic power system was rejected for the PLR primary power supply.

3.1.2 Dynamic isotope power system (DIPS)

The DIPS system uses a general purpose heat source (GPHS) which converts the heat supplied by radioisotope elements into electrical energy with the use of a dynamic conversion system (i.e. a generator).

Two DIPS systems are considered for the PLR are: Brayton cycle engine (BC), and a stirling cycle engine (SC). Table 3.3.2 summarizes the DIPS parameters.

TABLE 3.3.2
DIPS PARAMETERS (Ref. 12, 13, 14)

Engine	Brayton cycle	Stirling cycle
Power output	6.7 kw	6.7 kw
Specific power	7.5 w/kg	8.0 w/kg
Conversion eff.	20.5%	23%
Dimensions:		
length	7 m	6.5 m
diameter	4.3 m	4.1
System mass	1235 kg	1100 kg

We can see that both the BC and the SC DIPS system have high conversion efficiencies. Although these efficiencies are encouraging, the DIPS mechanical complexity eliminates this as the choice for our PLR power system. A single point failure in

the dynamic engine could result in complete loss of power. In order to guard against such failures multiple spares would have to be supplied (Ref. 12) which would result in unwanted excess mass. For example, to insure redundancy of a drive shaft, the PLR needs to have spare for which would add considerable mass and occupy much needed volume. For this reason the DIPS system was rejected as the PLR power supply.

3.1.3 Radioisotope Thermoelectric Generator (RTG)

An RTG also uses a GPHS, but unlike the DIPS system, it converts heat directly into electrical energy. The RTG does not require a dynamic conversion system and therefore the fear of total power loss due to a single failure does not exist. With the modular RTG, the total power will be supplied by several power modules. Hence if a single module should fail, the PLR will not lose total power and will continue to be operational.

In case of module failure, the PLR could return to the lunar base using the remaining power. The performance characteristics of the PLR will change under this circumstance, but the PLR will remain operable.

Two RTG systems were considered: alkali metal converter design (ARTG) and silicon germanium (SRTG). Table 3.3.3 lists the system attributes.

The RTG meets all of the design criteria for the PLR. Unlike the photovoltaic system, it does not require a second source for primary power for lunar night operations. Also, the

RTG provides the needed redundancy system survivability, eliminating the need for excess mass spare parts.

Because of the attributes listed above and its higher efficiency than the ARTG, the SRTG will be the primary PLR power supply.

TABLE 3.3.3
RTG PARAMETERS (Ref. 15, 16, 17)

System	ARTG	SRTG
Power output	6.7 kw	6.7 kw
Specific power	7.0 w/kg	8.5 w/kg
Conversion efficiency	9%	10.5%
Dimensions:		
length	3.5 m	2.5 m
diameter	2.0 m	2.0 m
System mass	1100 kg *	1000 kg
* includes wiring mass		

3.2 PLR POWER SUPPLY

The primary design parameter to consider with the use of the RTG is crew safety. This factor is one of two which lead to the use of the RTG in tow. The second is the versatility of having the RTG in tow.

If the RTG should fail, the crew will not be in immediate danger and the RTG could be detached from the PLR for safety.

The RTG is towed by the PLR in a 2 wheeled trailer. The trailer houses the RTG and the required thermal controls of the thermoelectric generator. Because of its external deployment, less radiation shielding is required. The RTG shielding consist of multi layer foil system in order to protect the crew. This, in combination with the foil shielding of the PLR, will provide adequate radiation protection for the crew members.

The external positioning of the RTG creates versatility. Because the RTG is in tow, the PLR can leave the power source at a remote battery charging station away from the lunar base. This performs three desired tasks; 1) the RTG power can be used to charge lunar base batteries when the PLR is not in operation, 2) the lunar base will be safer with the RTG at a distance, and 3) docking to the lunar base will be less complex with the trailer unhooked. Also, the RTG can be used as a power supply for many other needs, such as construction machinery, when the PLR is not operational. The towing trailer is illustrated in Figure 3.4.1.

ORIGINAL PAGE
COLOR PHOTOGRAPH

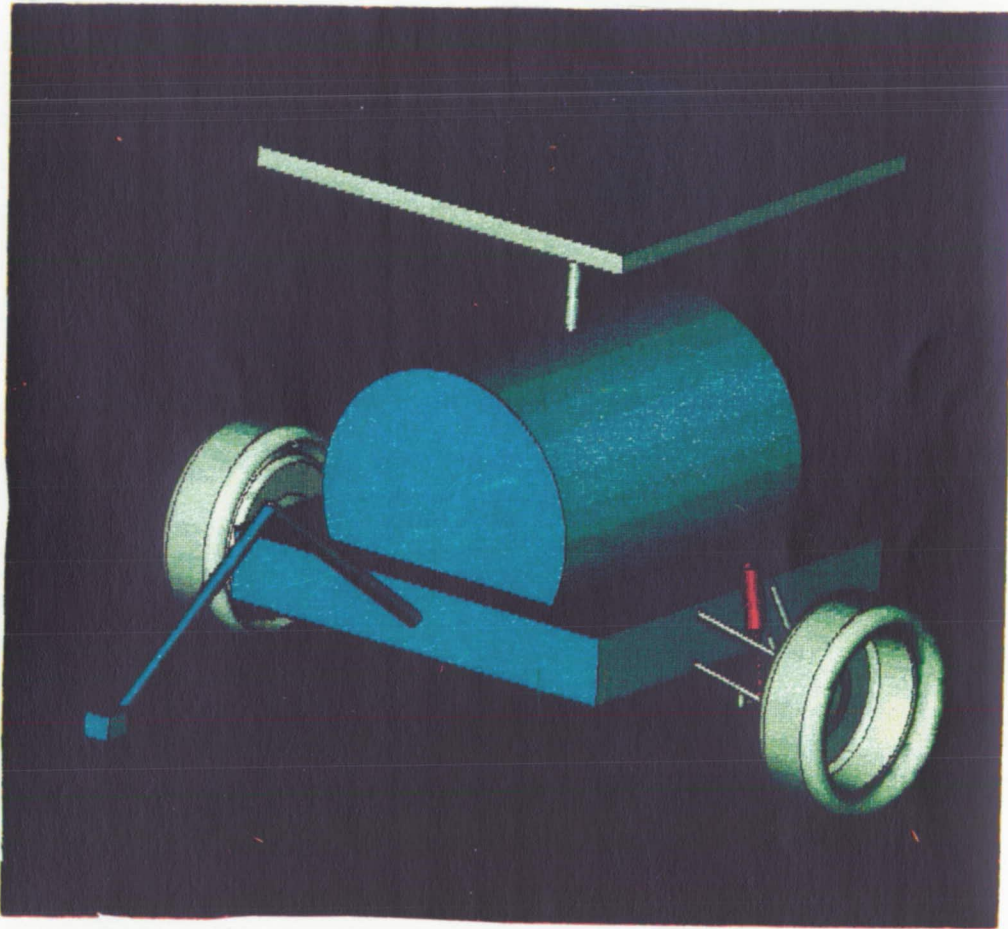

PRECEDING PAGE BLANK NOT FILMED

The diagram below illustrates the power distribution of the rover.

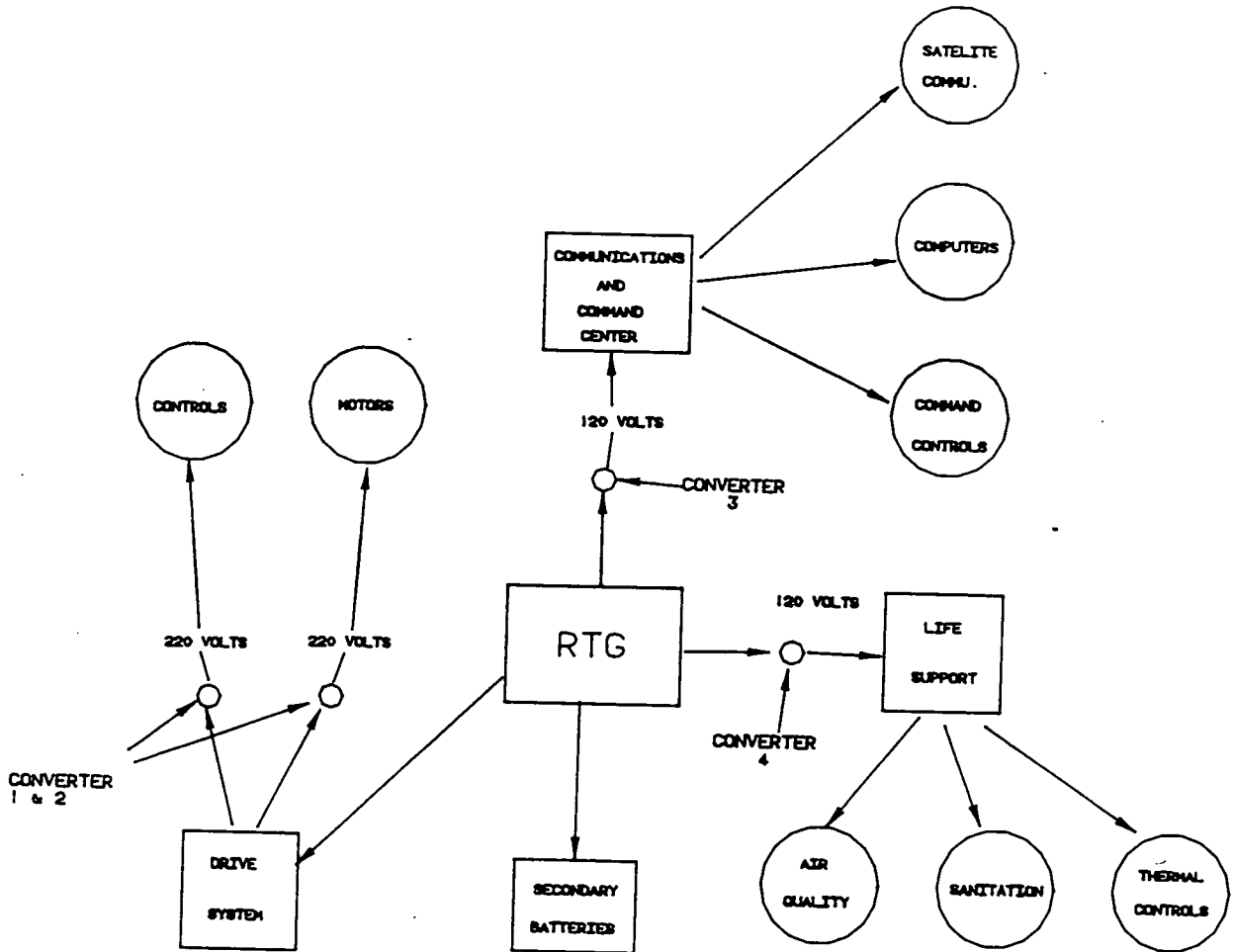

RTG POWER DISTRIBUTION

Figure 3.4

We can see that the drive train requires the bulk of the power. When the PLR is stationary, the excess power is used to charge the on-board batteries.

There are 4 separate converters (Figure 3.4). Converters 1 and 2 are used to supply power at the needed voltages to the drive system. DC-to-AC converter 4 supplies power to the life support components and converter 3 supplies power for the communications and command center.

The motor wiring is at the bottom right and bottom left beneath the flooring of the PLR and spans the length of the PLR. Life support and communications wiring span the PLR in the top panels through a wiring harness(Fig 3.4.2).

The PLR requires an additional 3 kw for peak power demands (Section 3.2). This power will be supplied by the on board batteries.

The secondary batteries are continuously charged by the RTG at 200 watts. A small array placed on the thermal control radiator shield will be used for battery charging when the RTG is detached (Fig. 3.4.3). The radiator shield is pointed towards space, away from the sun. Therefore, the array always faces the sun, providing maximum solar exposure.

The RTG is liquid cooled. The required radiator area is 9 m² (Appendix 3.1). The radiator is positioned on a boom on top of the RTG housing and is connected to the RTG by a thermal joint which allows the radiator to be steered.

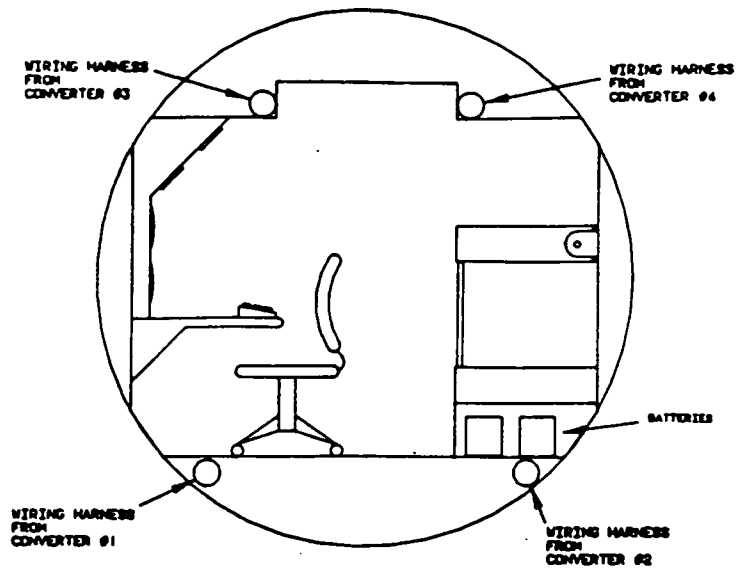

WIRING POSITION
FIGURE 3.4.2

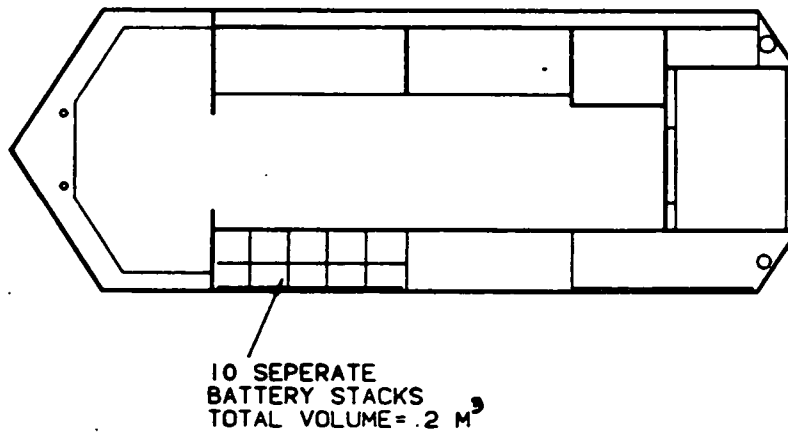

BATTERY HOUSING
FIGURE 3.4.3

3.3 BATTERY POWER SUPPLY

The PLR's peak power supply is provided by batteries. Two battery types were considered: nickel-hydrogen (NiH₂) and lithium sulfur dioxide (Li-SO₂). Table 3.5.1 lists their parameters (see Appendix 3.2 for details). The Li-SO₂ was chosen because of its higher discharge tolerance and its energy density.

Table 3.5.1*
Battery specifications (Refs. 19 and 20)

Battery type	Li-SO ₂	NiH ₂
Energy density	300 w.h/kg	70 w.h/kg
Degree of discharge	70 %	60 %
Number of cycles	1000	1500
Total mass	200 kg	350 kg

There are ten separate stacks, each containing 10 cells in series to supply 6 kW-hrs (Appendix 3.2). These batteries are placed under the crew beds in the midsection of the PLR. The crew is able to easily service them through access panels (Figure 3.4.3). Each battery has the dimensions of .3m x .15 m x .15 m. Total battery volume is .2 m³.

3.4 SUMMARY

The PLR's power needs are met by a modular radioisotope thermoelectric generator. The RTG is in tow, mounted on a two wheeled trailer. Converters are placed at the back of the PLR

to regulate the voltage needs of the components of drive train, life support, and communications systems.

Peak power is met by the use of a secondary battery supply. These batteries are charged by the RTG continuously. A system mass summary is shown below.

Power System Mass Summary

RTG	1000 kg
Wiring	150 kg
Radiator system	150 kg
Batteries	200 kg
Total system mass	1500 kg

4.0 LIFE SUPPORT SYSTEM

The PLR requirements place great demands on the Life Support System (LSS). The LSS must maintain a comfortable and pure atmosphere, supply water for PLR operations and crew health and hygiene, provide nourishing and appealing food, sanitarily dispose of all waste products, and maintain the crew's mental and physical health. In addition, the LSS must perform these requirements with simplicity, reliability, and minimum system mass and power consumption. Table 4-1 details the design loads.

The LSS breaks into five modules, each focusing on a major LSS requirement. The five modules are:

Air Revitalization Module
 Water Management Module
 Food Provision Module
 Waste Disposal Module
 Crew Health Module

Figure 4-1 is a functional diagram of the LSS.

TABLE 4-1: Design Loads (Refs. 21, 22, 23; App. 4-1)

Max. Heat Load	2.540 kW	EVA O ₂	0.55 kg/m-E
Electronics	0.544 kW	Metabolic O ₂	1.66 kg/m-d
LSS	1.717 kW	Air Leakage	2.27 kg/day
Max. Environment	0.279 kW	Airlock Loss	0.60 kg/use
Perspiration H ₂ O	1.82 kg/m-d	EVA CO ₂	0.67 kg/m-E
Handwash H ₂ O	1.81 kg/m-d	Metabolic CO ₂	2.00 kg/m-d
Drinking H ₂ O	1.90 kg/m-d	Hygiene H ₂ O	0.44 kg/m-d
Dishwasher H ₂ O	5.67 kg/m-d	Urinal Flush	0.49 kg/m-d
Food Prep. H ₂ O	0.72 kg/m-d	Shower H ₂ O	5.50 kg/m-d
EVA Wastewater	0.91 kg/m-E	EVA H ₂ O	4.39 kg/m-E
Trash	0.82 kg/m-d	Food Mass	1.18 kg/m-d
Trash Volume	0.0028 m ³ /m-d	Urine	1.50 kg/m-d

m-E = man-8 hr EVA

m-d = man-day

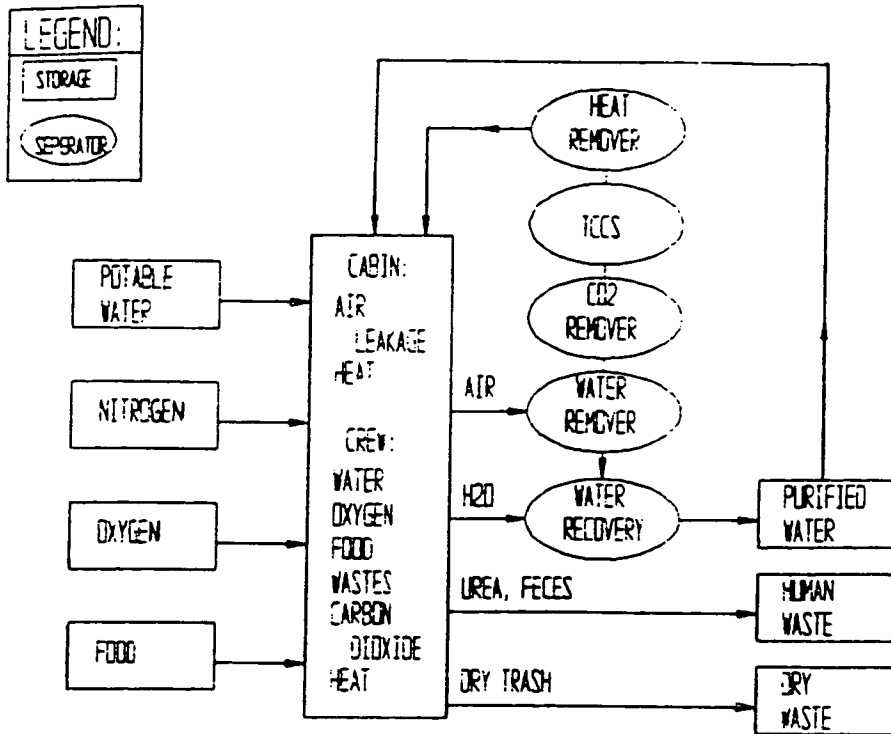

FIGURE 4-1: LSS FUNCTIONAL DIAGRAM

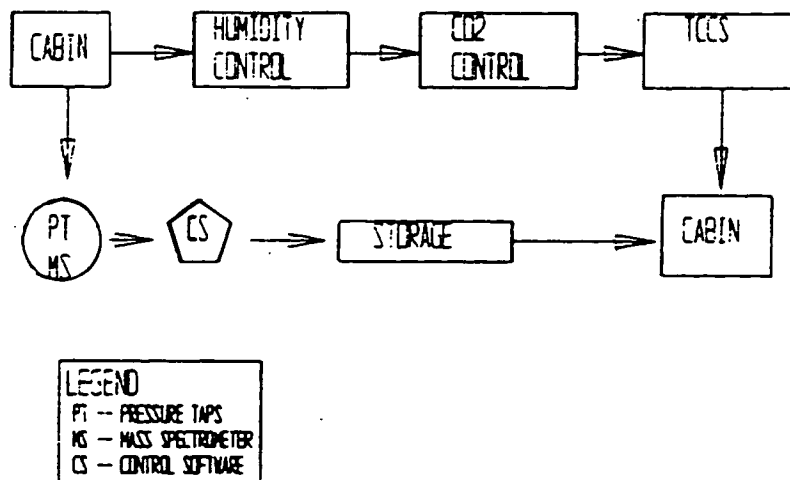

FIGURE 4-2: ARM FUNCTIONAL DIAGRAM

4.1 AIR REVITALIZATION MODULE

The Air Revitalization Module (ARM) maintains a cabin atmosphere with nominal characteristics of (Refs. 23, 24, 25):

Pressure	-- 1.0 atm
Temperature	-- 295 K
Relative Humidity	-- 50 Percent
Composition:	-- 79 Percent Nitrogen
	-- 21 Percent Oxygen

To accomplish these requirements, the ARM employs six systems that replenish cabin oxygen and extract heat, water vapor, carbon dioxide, and trace contaminants from the cabin. In addition, the ARM checks air quality and detects fires. The six systems that comprise the ARM are:

- Thermal Control System
- Humidity Control System
- Carbon Dioxide Removal System
- Trace Contaminant Control System
- Pressure and Content Control System
- Fire Detection and Prevention / Quality Control System

Except for the Pressure and Content Control System, all of the above systems are interconnected, as Figure 4-2 displays. In addition, Figure 4-3 details the ARM's interconnected systems layout above the cabin ceiling.

4.1.1 Thermal Control System

This system regulates cabin temperature and circulates air. The lunar climate requires a flexible thermal control system. While the sun's radiation strikes the PLR, the Thermal Control System removes excess heat due to solar radiation, lunar radiation, lunar-reflected solar radiation, crew metabolism, and electronics. The maximum excess heat load is 2540 W (Table 4-1).

LEGEND	
—	COOLANT LOOP
---	AIRFLOW LINES
	DUCTING
	FAN
	HEAT EXCHANGER
	LION CANISTER
	CHARCOAL CANISTER
	BLOWER
	TREATED CHARCOAL CAN
	CO OXIDIZER
	QUALITY CONTROL
	PUMP
	HEAT PUMP
	WALL COOLANT
	FLOOR COOLANT
	CEILING COOLANT

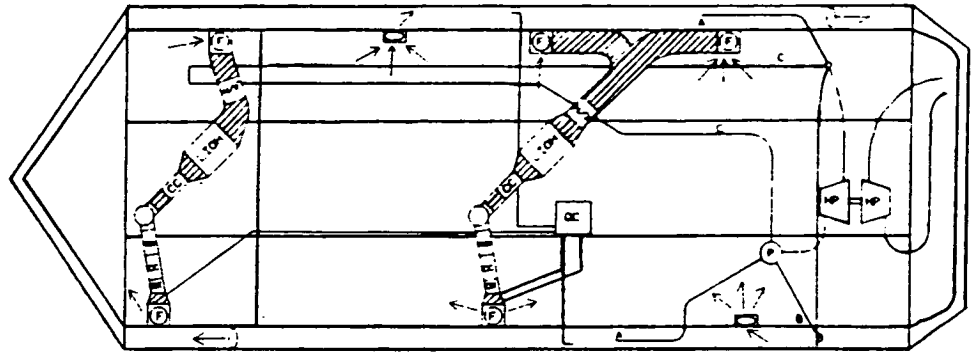
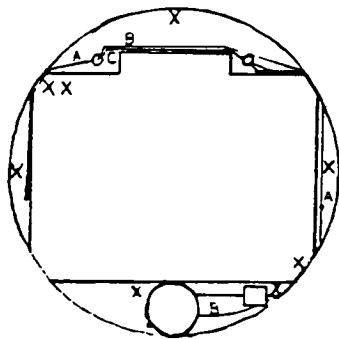

FIGURE 4-3: ARM CEILING LAYOUT

LEGEND	
A	WALL COOLANT
B	FLOOR COOLANT
C	CEILING COOLANT
X	FIRE ALARM
O	LOOP JUNCTURE



FRONT VIEW

TOP VIEW

SIDE VIEW

FIGURE 4-4: THERMAL BUS

The heat extraction and circulation systems are basically seven fans and a condensing heat exchanger (Refs. 23, 25). Two fans are for circulation purposes only. The remaining five fans bring air through cabin vents, through the ARM systems, and then return the air to the cabin. The three entrance vents located in the command center, galley, and bathroom have screens that prevent lint and dust from contaminating the condensing heat exchanger. After passing through the vents, the airstream enters the condensing heat exchanger which removes excess heat. Fan speed sets the cooling rate and fan orientation forms the circulation pattern. Once the airstream exits the ARM systems (discussed below), it leaves through two exit vents, located in the command center and above the sleeping quarters. The entrance and exit vents provide a good circulation pattern for the rover (see Fig. 4-3). Four fans between the cabin walls and rover inner shell provide additional circulation. Cooling loops behind the walls extract waste heat. The loops transfer the heat to the radiator system which radiates the heat to empty space. Figures 4-2 and 4-3 show the Thermal Control System in conjunction with other ARM systems. Figure 4-4 details the thermal bus.

The lunar climate has the potential to inflict large positive and negative heat fluxes on the PLR. However, to reduce this potential, thirty layers of Multi-Layer Insulation (MLI) reflect solar radiation and greatly reduce conductive heat transfer (Ref. 23). The use of the MLI results in much less loads on the Thermal Control System and thus reduces the system's mass and power consumption which drives down launch costs.

In disposing excess heat, a heat pump augmented radiator system proves to be superior to a radiator-alone system. Heat pumps, either electrically or thermally driven, increase the radiator's temperature with heat from a high temperature source. The best thermal heat pumps (Fig. 4-5) are hermetically sealed to minimize fluid leakage and utilize a Rankine-Rankine cycle which is superior to other cycles (Stirling, Brayton) with respect to mass, performance, and efficiency. An electrically driven heat pump uses a Rankine cycle and operates with on-board power. For both types of heat pumps, the best performing fluid is a blend of non-azeotropic fluids (Ref. 26). The thermally driven heat pump system is chosen on the basis of power consumption and minimum leakage. The heat pump is located above the ceiling (Fig. 4-3). The RTG supplies heat to the heat pump. A loop runs from the heat pump to the RTG's radiator and is clamped to the hitch connecting the PLR and trailer. The loop gains its heat through conduction with a small portion of the radiator's area. In the

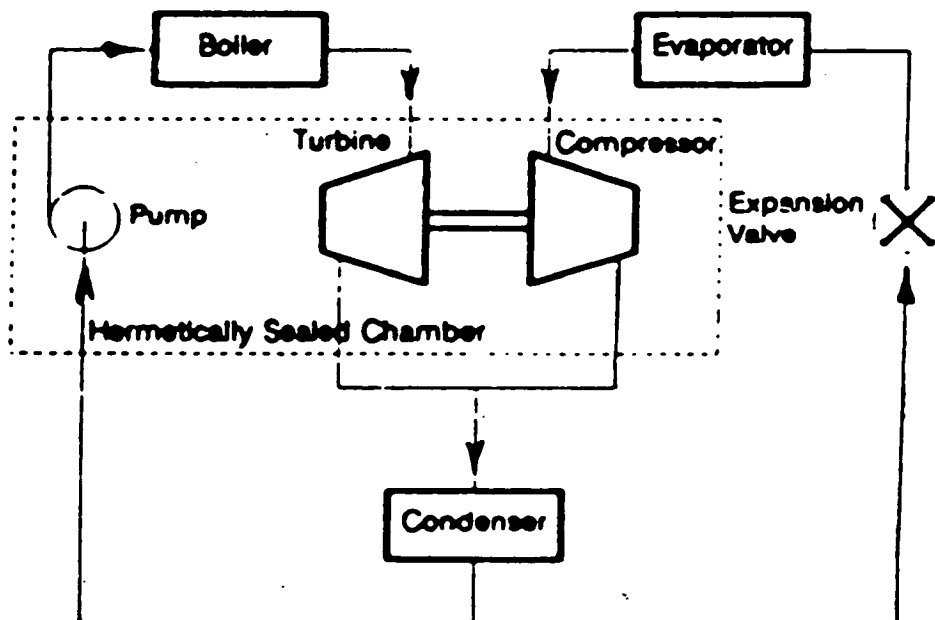

FIGURE 4-5: THERMALLY-DRIVEN HEAT PUMP

unlikely event of an RTG emergency, the secondary heat supply (below) provides heat for the heat pump.

The heat pump results in less system mass and radiator area because radiative heat is proportional to the fourth power of temperature (Ref. 26). A radiator-alone system, rejecting 2.54 kW at 300 K, requires a radiator area of 10.39 m². In contrast, the heat pump augmented radiator system, rejecting 2.54 kW at 400 K, needs a radiator area of 3.283 m² (Ref. 26). The area reduction produces radiator mass reductions on the order of 10 kg/m². Since the heat pump mass is 11 kg/kW-cooled, there is a net mass savings of 43 kg. See Appendix 4-1 for the above calculations. In conclusion, the design calls for a thermally-driven heat pump augmented radiator (3.283 m²), which is mounted on top the PLR (Fig. 2-1). To effectively radiate heat, the radiator must point toward empty space. The radiator is shaded from the sun by a solar shield. The solar shield uses a solar sensor to orient the shield toward the sun; hence, the radiator is pointing away from the sun.

Note, the RTG's radiator could be used for cooling the PLR, but this option is ruled out for several reasons. First, in the case of an RTG emergency, the trailer is disconnected and the PLR runs on secondary power. In such an event, the PLR needs a back-up radiator to dispose of excess heat. Thus, in this respect, there is no advantage in using the RTG's radiator to dispel the PLR's excess heat. Second, the RTG's radiator operates at very high temperatures and thus the working fluid leaving the radiator is too hot to cool the PLR. It is possible to cool the fluid,

but not without added complexity, mass, and power consumption. Third, the RTG coolant system is radioactive. Thus, if the RTG and PLR Thermal Control Systems are directly linked, the PLR coolant system is radioactive. As a result, additional shielding in the PLR is required. Therefore, the PLR and RTG Thermal Control Systems are not directly linked.

The PLR may encounter missions that require a heat supply. For example, a lunar night mission with endothermic experiments or a lunar night mission with an airlock door failure would require a heat source. In such scenarios, the Thermal Control System supplements electronic and metabolic heat to maintain temperature. Several options provide heat. The ideal solution sends heat from the RTG to the PLR. A second option uses exothermic chemical reactions to provide heat. A third option uses latent heat storage to release heat over time. The design calls for a combination of the above. The loop that supplies heat to the heat pump during day missions supplies heat during such scenarios. This serves as the primary system. The loop transfers heat to some of the coolant loops which become heating loops. Additionally, during the PLR radiator is by-passed. A latent heat storage system serves as the secondary system. This system is comprised of insulated canisters that contain phase changing material. The chosen material is N-Eicosane which melts at 309.7 K. N-Eicosane is chosen because of its high density and thermodynamic qualities (Ref. 27). The N-Eicosane canisters are charged with heat at the base and/or during lunar day. The canisters are properly insulated such that the cabin temperature

stabilizes near 295 K. Since N-Eicosane's melting temperature is higher than the desired PLR temperature, the canisters supply heat two ways. First, the canisters lose sensible heat while the temperature drops to 309.7 K. Then they lose latent heat as the N-Eicosane solidifies. Then the canisters lose sensible heat as the temperature drops to 295 K. The canisters are placed near the heat pump system to facilitate charging and heat distribution (Fig. 4-3). Appendix 4-1 gives calculations associated with the N-Eicosane analysis.

4.1.2 Humidity Control System

Once the fan system draws air from the cabin, it flows into the Humidity Control System (Figs. 4-2, 4-3) which removes the desired amount of water vapor by cooling the airstream such that some of the water vapor condenses. The Thermal Control System's condensing heat exchanger serves as the Humidity Control System's water extraction device (Ref. 28). The fan speed controls the rate of extraction. Once removed, the water goes to the Water Recovery System. The Humidity Control System removes 1.82 kg of water per man-day (Table 4-1).

4.1.3 Carbon Dioxide Removal System

After exiting the Humidity Control System, the airstream enters the Carbon Dioxide Removal System (Figs. 4-2, 4-3) which removes carbon dioxide (CO₂) and odors. As Table 4-1 shows, the peak required removal rate of CO₂ is 2.0 kg per man-day plus 0.67 kg per man-8 hour EVA. For this system there are two options.

The first option is based on the Space Station design which removes CO₂ and uses a Bosch reactor to produce carbon and water

(Ref. 29). Due to the complexity, mass, power, and volume of such a system, it is eliminated from consideration.

The chosen option uses lithium hydroxide (LiOH) and activated charcoal sorption beds which remove CO₂ and odors, respectively (Ref. 30). Since the nominal airstream condition for this system is fifty percent relative humidity, it proceeds the Humidity Control System. The beds need periodic replacement because this system is non-regenerative.

4.1.4 Trace Contaminant Control System (TCCS)

Upon exiting the Carbon Dioxide Removal System, the airstream enters the Trace Contaminant Control System (Figs. 4-2, 4-3) which removes any contaminants from the air that may harm the crew, in particular carbon monoxide (CO). Research performed at the George C. Marshall Space Flight Center and the Skylab system are the basis of this system's design (Refs. 29, 31). This system is also non-regenerative and requires periodic component replacement.

There are three segments to the TCCS. The first is a sorption bed containing 1.8 kg of activated charcoal treated with phosphoric acid (2 mmol/ mol). The second is a sorption bed containing 2.38 kg of activated charcoal. The third is a bed that contains 0.336 kg of activated charcoal with a 2 percent platinum catalytic oxidizer. The catalyst requires at least a 0.02 second bed residence time for 100 percent oxidation of CO.

Additionally, if the PLR is not depressurized at the lunar base, it is necessary for the base to occasionally operate a high temperature oxidizer to consume the PLR's methane build-up.

4.1.5 Pressure and Content Control System

The Pressure and Content Control System maintains cabin pressure and composition by accounting for air leakage and oxygen consumption. Table 4-1 gives the leakage and consumption rates. The system monitors cabin pressure and composition with pressure taps and a mass spectrometer (Refs. 32, 33). Control software in the LSS control computer use the measurements to decide if, and how much, nitrogen (N_2) and oxygen (O_2) should be released into the cabin from storage tanks. Appendix 4-2 contains the N_2 and O_2 storage tank dimensions. Figure 4-6 shows the placement of the N_2 and O_2 storage tanks and the lunar resupply network.

4.1.6 Fire Detection and Prevention/Quality Control System

Finally, the Fire Detection and Prevention System detects fires and alerts the crew. Fire detectors are located throughout the PLR (Fig. 4-4, each marked by an X). The detectors are simple battery operated detectors and GC-Mass Spectrometer systems. When an alarm indicates a fire, the crew may use an on-board CO_2 fire extinguisher (Refs. 25, 34).

The Quality Control System ensures environmental integrity. This system monitors the quality of the air that exits the ARM (Figs. 4-2, 4-3). It includes the mass spectrometer used by the Pressure and Content Control System.

4.1.7 Air Revitalization Module Conclusion

This concludes the overview of the Air Revitalization Module. The module is installed between cabin ceiling and rover inner shell (Fig. 4-3). There are two sets of Thermal, Humidity, Carbon Dioxide, and Trace Contaminant Control Systems for several

reasons (Fig. 4-3). First, the safe haven requires its own ARM. Second, it reduces the ducting system's complexity. Finally, it provides redundancy against partial system failure.

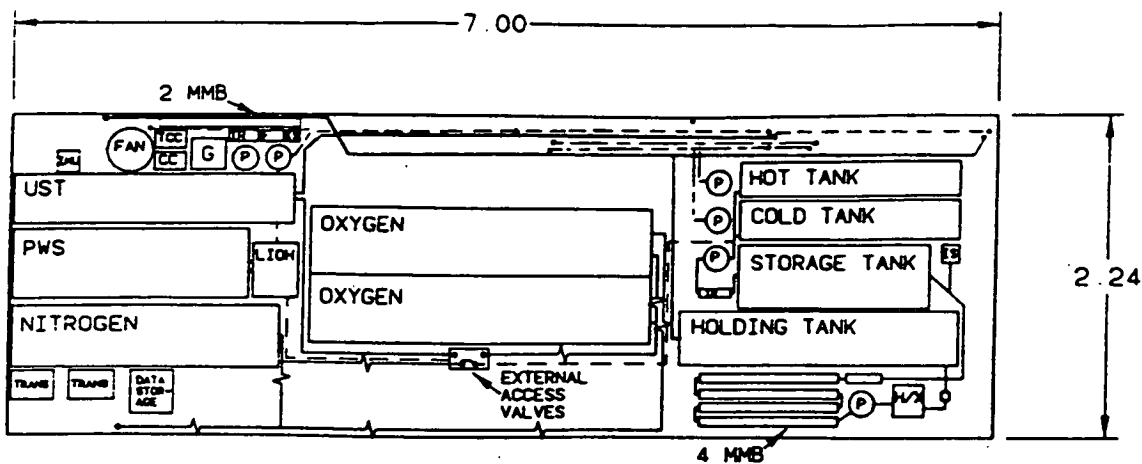

FIGURE 4-6: FLOOR LAYOUT
(See App. 4-4 for symbol definition)

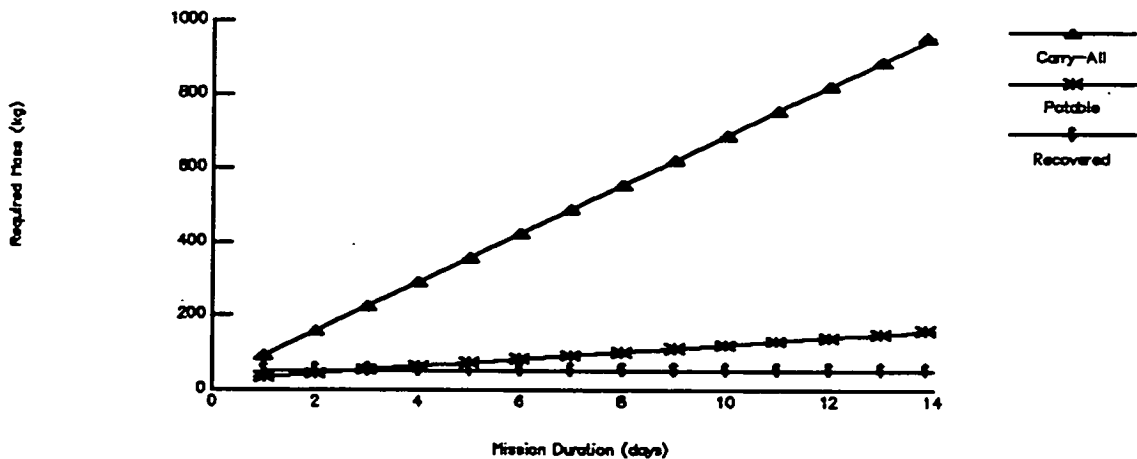

FIGURE 4-7: WMM OPTIONS COMPARISON

4.2 WATER MANAGEMENT MODULE

The Water Management Module (WMM) provides potable water for drinking, cooking, EVA, cleaning, and hygiene purposes. Table 4-1 gives the system loads. At the forefront of the WMM design, the issue of recycling emerges. An investigation of the subject shows that it is advantageous to use a recycling system.

As Figure 4-7 shows, a non-recycling system (denoted by the Carry-All line) requires a substantial greater initial supply of water. This produces much larger storage tanks and added structural complexity. This results in larger vehicle mass, and thus increases the amount of power required to propel the rover, in addition to increasing launch costs.

A recycling system, on the other hand, results in lower vehicle mass, smaller vehicle size, lower launch costs, and less strain on the lunar base's water reserves. In Figure 4-8, the potable line is the initial water supply that is recycled throughout the mission. The recovered line represents required potable water supply which is not mixed with the recycled water for redundancy purposes.

Therefore, as a result of this analysis, a recycling system is chosen over a non-recycling system. The recycling system consists of two parts: a potable water supply and a water recovery system.

4.2.1 Potable Water Supply

The potable water supply (PWS, Fig. 4-6) consists of a storage tank containing 0.3 m^3 of water for drinking, food preparation, and EVA purposes.

4.2.2 Water Recovery System

This system supplies water for various cleaning and hygiene purposes. The water recycling, or recovery, system chosen for the PLR is based on research and design performed at the Umpqua Research Company in Myrtle Creek, Oregon (Refs. 35, 36, 37). Figure 4-8 shows the system. The wastewater goes through a filter (100 mesh polyester) and collects in a holding tank which is heated to 355 K to retard microbe growth. The water then goes through a heat exchanger which cools the flow. A pump drives the water through a series of four multi-media sorption beds (MMB, 1" radius, 40" length). The MMB's remove all contaminants except alcohols. Figure 4-9 shows a diagram of the multi-media bed, or unibed design. The flow rate through the beds is 79 cc/min and the average velocity through each bed is 3.9 cm/min, which gives a contact time of 26 minutes (See Appendix 4-3). One MMB exhausts its media every 140 hours of processing; this is because the usage rate of the absorption media is 3.1 cc/liter of processed water. At this rate, a bed requires replacement roughly every 10 days of operation (See Appendix 4-3). However, this system operates adequately without four usable MMB's.

After the water exits the MMB's, a catalyst removes alcohols. Then the water enters a storage tank and iodine is added to ensure sterility. Next, the water enters an iodine removal bed and goes into either a cold or hot storage tank. The water leaves the tanks as demanded. Prior to the first mission, the lunar base half fills the hot and cold tanks with water.

CROSS SECTION VIEW (2.22" = 1 m)

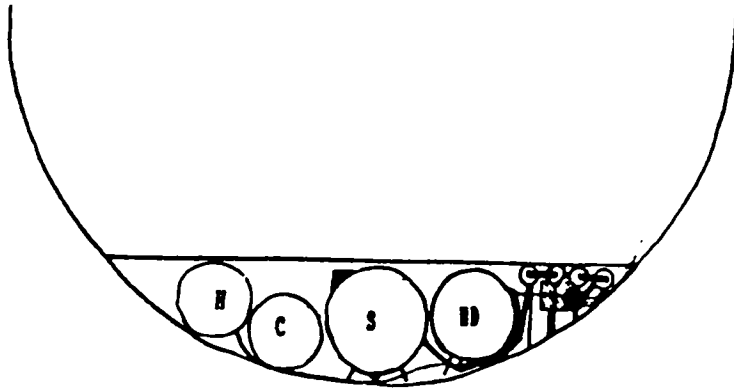

TOP VIEW (1.25" = 1 m)

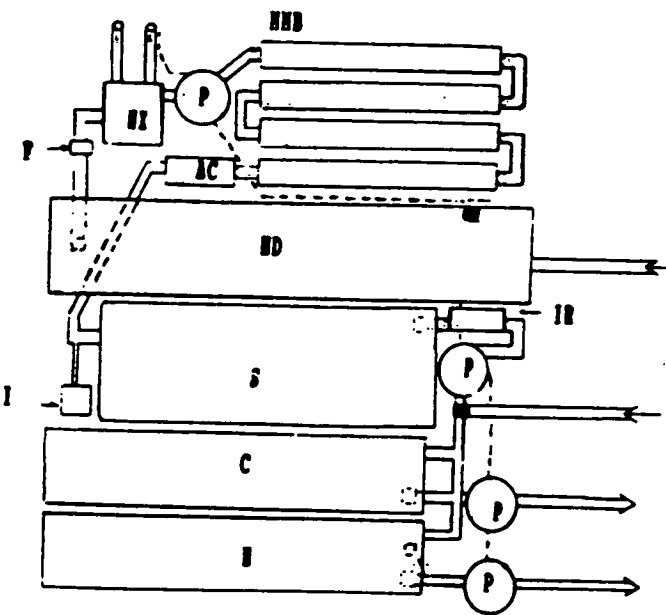

LEGEND :

- | | |
|--------------------------------|-----------------------|
| AC - Alcohol Removing Catalyst | I - Iodine Adder |
| C - Cold Water Tank | IR - Iodine Remover |
| P - Filter | MND - Multi-Media Bed |
| H - Hot Water Tank | P - Pump |
| HD - Holding Tank | S - Storage Tank |
| HX - Heat Exchanger | V - Electrical Wire |

FIGURE 4-8: WATER RECOVERY SYSTEM

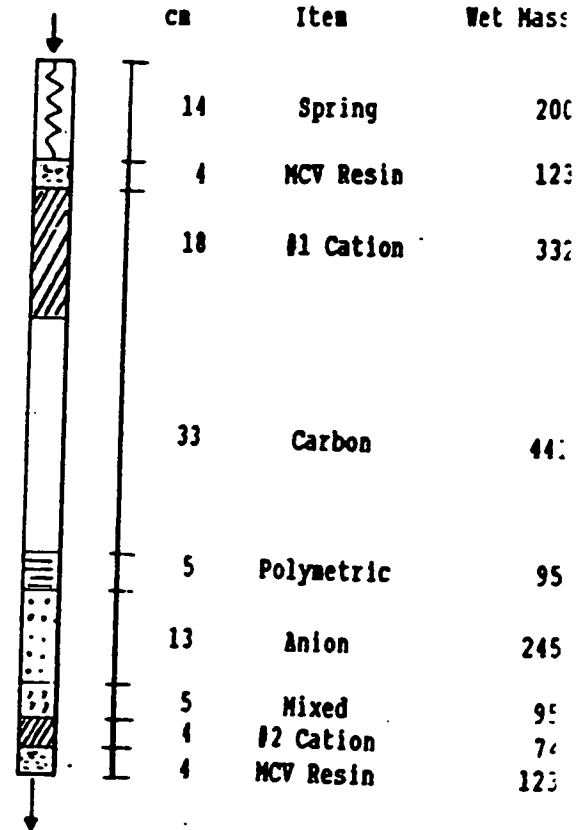

Total Bed Mass = 1728 g
 + Housing 250 g
 Net Total Mass = 2 kg

FIGURE 4-9: MMB DESIGN

4.2.3 Water Management Module Summary

The WMM is comprised of two components, a potable water supply and a water recovery system. The PWS supplies potable water. Between PLR missions the lunar base supplies the potable water. A system of non-regenerative multi-media beds compose the water recovery system. Figure 4-6 shows the layout of the WMM and the resupply network. Figure 4-10 is the rover's water distribution network. Appendix 4-2 contains computations for each system's tank dimensions.

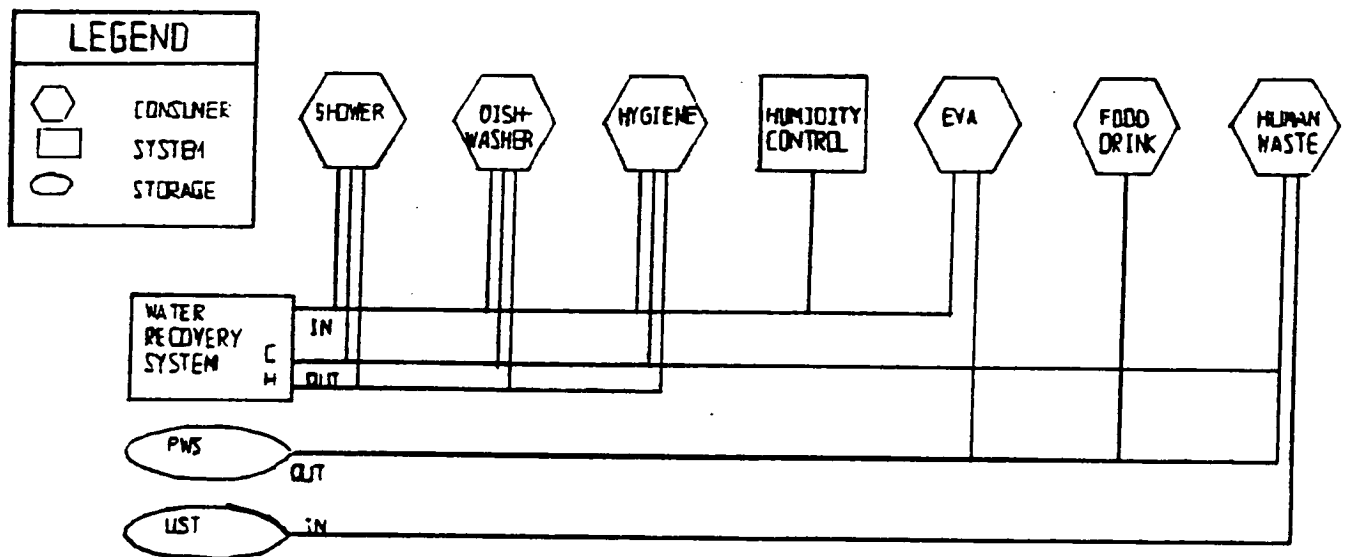

FIGURE 4-10: WATER DISTRIBUTION NETWORK

4.3 FOOD PROVISION MODULE

The Food Provision Module (FPM) provides the crew with nourishing and acceptable food and drink. The lunar base supplies the food and powdered drinks. This module has been

designed under the assumptions that the supplied food is dehydrated, canned, and/or storable at ambient conditions (Ref. 38). An energy-efficient microwave prepares food. To reduce the amount of trash, the packaging should be kept to a minimum. Furthermore, non-disposable eating utensils are used and cleaned with a compact, energy-efficient dishwasher.

4.4 WASTE DISPOSAL MODULE

The Waste Disposal Module (WDM) disposes waste materials in a sanitary method that ensures crew health. In addition, the WDM stores wastes in such a manner that facilitates recycling at the lunar base. This system handles two types of waste: dry waste and human waste. Accordingly, two waste disposal systems, Dry Waste Disposal and Human Waste Disposal, comprise the WDM.

4.4.1 Dry Waste Disposal

Dry waste disposal may be achieved by simple trash cans. However, PLR space constraints eliminate this option. A compactor is the next logical option because the PLR's type of trash is easy to compact. Two compactor options are examined. Figure 4-11 shows each compactor.

The first compactor option is an electric trash compactor. Power and mass estimates based on a SEARS model (72 kg, 780 W) eliminate this option from consideration (Ref. 39).

The second option is a hand crank compactor. This model operates easily and requires zero electrical power.

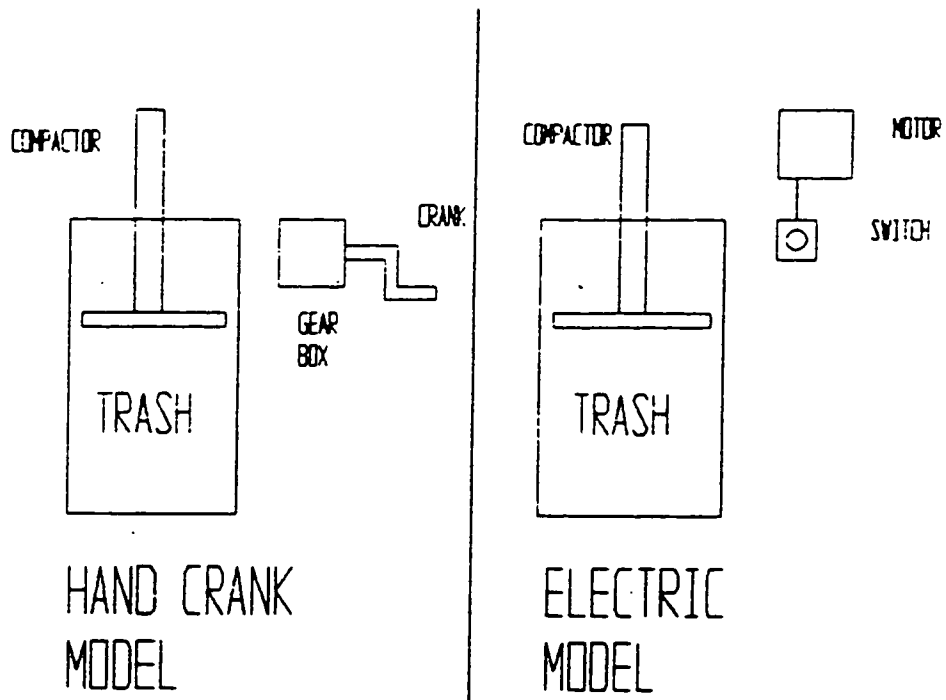

FIGURE 4-11: COMPACTOR OPTIONS

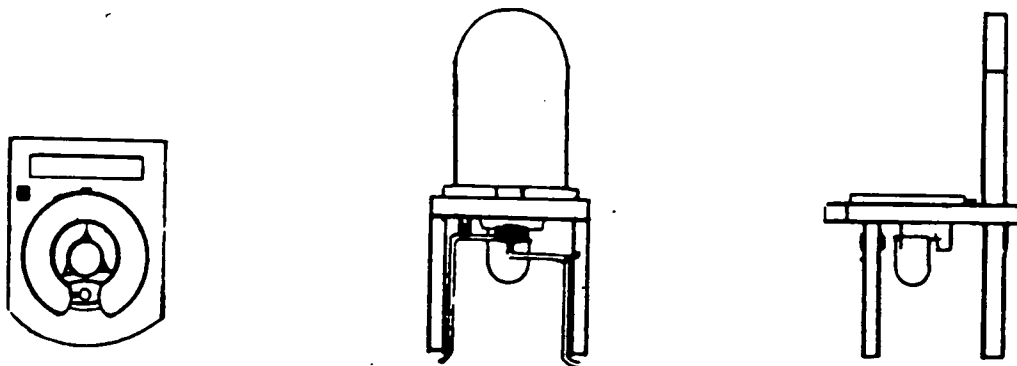

FIGURE 4-12: TOILET DESIGN

4.4.2 Human Waste Disposal

The Human Waste Disposal System acquires and stores human wastes in a sanitary manner. Because complexity eliminates an on-board waste recycling system from consideration, the design assumes recycling at the lunar base. This leaves two open-loop options for the PLR.

The first option employs an earth type toilet which uses water to store the wastes. The second option employs a system similar to the space station designs (Ref. 40). This system collects feces in bags and then compacts them. It collects urine separately with a personalized cup attached to a tube that connects to a urinal storage tank (UST, Fig. 4-6).

Each system has both advantages and disadvantages. The earth style toilet is simple and familiar to the crew but the storage system may develop maintenance problems. The second system uses less water and facilitates handling and recycling at the base but its compactor system is somewhat complex.

The design solution is a compromise between the two systems. It combines the earth model's simplicity and the space station model's ease of recycling and water savings. A personalized cup collects urea and a water-iodine mixture carries the urea to the UST. Collection bags collect feces and vomitus. Crew members, after each use, remove the collection bag, 'zip-loc' it, and deposit it into the sanitary storage box. Finally, a new bag is put into place so the toilet is ready for the next use, which facilitates an emergency. Figure 4-12 displays the design concept and Figures 4-6 and 4-10 detail the UST. Figure 4-6

details the piping network associated with the UST which the lunar base uses to remove the urea-water mixture from the PLR and send it to the base's recycling system. Appendix 4-2 contains calculations for the UST dimensions.

4.5 CREW HEALTH MODULE

The Crew Health Module (CHM) serves to improve crew morale and maintain health. For crew morale, many options exist, which include playing cards and exercise equipment. The design calls for an exercise bike which serves two purposes. First, it provides a complete workout for each crew member. Second, during operation, it charges the PLR's batteries. A system such as an exercise bike connected with a generator or battery charger is advantageous because it provides exercise to the crew and, at the same time, eases the load on the power supply systems.

For crew health, the design focus is radiation shielding. The shielding protects the crew from RTG radiation, nominal solar radiation, micrometers, and solar flare events. The RTG's shielding adequately protects the PLR from the power system's radiation. The thirty MLI layers (Section 4.1.1) block nominal solar radiation from the PLR. The PLR shell provides micrometer protection. Finally, the PLR's safe haven section provides solar flare protection. The safe haven encompasses the shell around command module and uses a 2.5 cm layer of water to shield the crew (See Fig. 2-3). Inside the PLR, an aluminum bulkhead stops flare particles that enter through the unshielded PLR section.

4.6 LSS SUMMARY

In conclusion, the LSS uses an active thermal control system coupled with sorption beds to maintain a comfortable and clean cabin environment which enables the crew to better perform their mission tasks. The LSS provides a potable water supply through the use of a non-regenerative recovery system and storage tanks. The LSS disposes waste products sanitarily via storage tanks and enables convenient extraction for recycling at the lunar base. Additionally, the LSS employs an exercise bike to provide exercise. Finally, various shieldings protect the crew from harmful radiation and micrometeors.

The LSS's mass and power totals are (from Table 4-2):

Mass : 765.0 kg (empty), 1,489.9 kg (stocked)

Power: 2,330.0 W (peak), 1,378.3 W (average).

The mass total does not include the shielding (see Structures).

TABLE 4-2: Mass and Power Totals

Item	Mass (kg)	Power (W)	Time (h)
ARM:			
Thermal Control:			
Fans (11)	14.85	330.0	24
Piping, pumps, etc	22.00	70.0	24
Radiator System	100.00	250.0	24
Heat Supply	150.00	0.0	N/A
Humidity Control	6.40	0.0	N/A
CO ₂ Control	60.00	0.0	N/A
TCCS	20.00	40.0	24
Pressure Control	9.00	0.0	N/A
Fire P+D/QC	150.00	400.0	24
WMM:			
Potable Supply	8.00	20.0	neglect
Water Recovery	49.80	100.0	12-14
FPM:			
Cabinets, etc	12.00	0.0	N/A
Microwave	10.00	600.0	neglect
Dishwasher	25.50	600.0	0.5
WDM:			
Dry Waste	8.00	0.0	N/A
Human Waste	20.70	20.0	neglect
CHM:			
Exercise Bike	25.00	0.0	N/A
Lights	6.00	300.0	18
Extra Supplies (App. 4-4):	67.75	0.0	N/A
Stocking (from Table 4-1):			
Air (N ₂ , O ₂)	223.80	0.0	N/A
Water	388.79	0.0	N/A
Food	112.34	0.0	N/A
TOTALS:			
(Dry)	765.00	2330.00	
(Stocked)	1489.93	1377.75	(Average P)

5.0 ELECTRONIC SYSTEMS

The PLR's electronic systems provides functions crucial to successful missions. The communications system allows the rover to maintain contact with both the lunar base and Earth during the mission. The navigational system provides important information on the rover's position and heading. The rover computer is an integral part of many systems, ranging from motor control to life support.

5.1 COMMUNICATIONS

Communication ability is a critical part of the PLR's overall functioning. The rover occupants must be able to report to, and receive instructions from both the lunar base and Earth. The requirements state that the PLR must be able to conduct direct voice, video, and data communication with Earth. In addition to providing person-to-person communication, the link sends data from science experiments to Earth or the lunar base. The rover is also equipped with short-range communications ability for EVA operations.

5.1.1 Earth-Moon Communication

The communications system takes advantage of lunar relay satellites assumed to be orbiting the Moon. This assumption is valid, since a pressurized lunar rover would only be in use in an advanced space program. Such a program would have many uses for communications satellites (i.e. far-side lunar projects). These satellites will be placed at the two lunar libration points (Ref. 47) providing both near and far-side coverage (Fig. 5-1). The

lunar relay satellites allow a significant reduction in the power needed to send signals to Earth.

The communications system uses X-band (8400-8500 MHz) for all the links. S-band was is not suitable because of the lower data transmission rates. K and Ka band provide very high transmission rates, but rely heavily on unproven technology (Ref 47). X-band has low power requirements while maintaining a relatively high data transmission rate of 20 Mbps. This data rate allows low quality television images to be transmitted. X-band gives good performance with proven technology. Using the on-board computer, compression and coding techniques are employed to reduce the size of the data to be transmitted. Data is sent in digital form to increase accuracy and eliminate error.

Two on-board transponders, allow simultaneous transmission and reception through two 0.9 m antennas. Dual transmission or dual reception is also possible. Figure 5-2 illustrates the communications system. Both signals are in X-band, but operate at frequencies at opposite ends of the X-band spectrum. This double-transponder, double-antenna design gives the system a measure of redundancy. If one antenna or transponder were to fail, the other could be used to alternately transmit and receive.

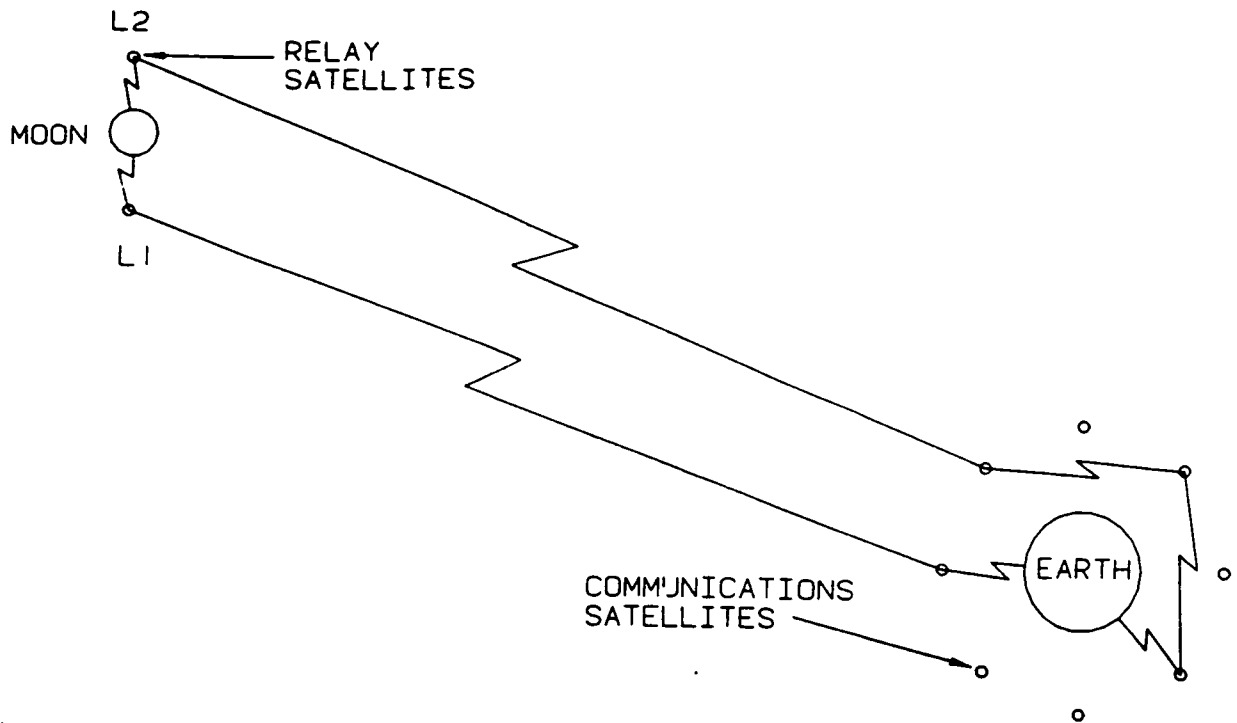

Figure 5-1: Earth-Moon Communications

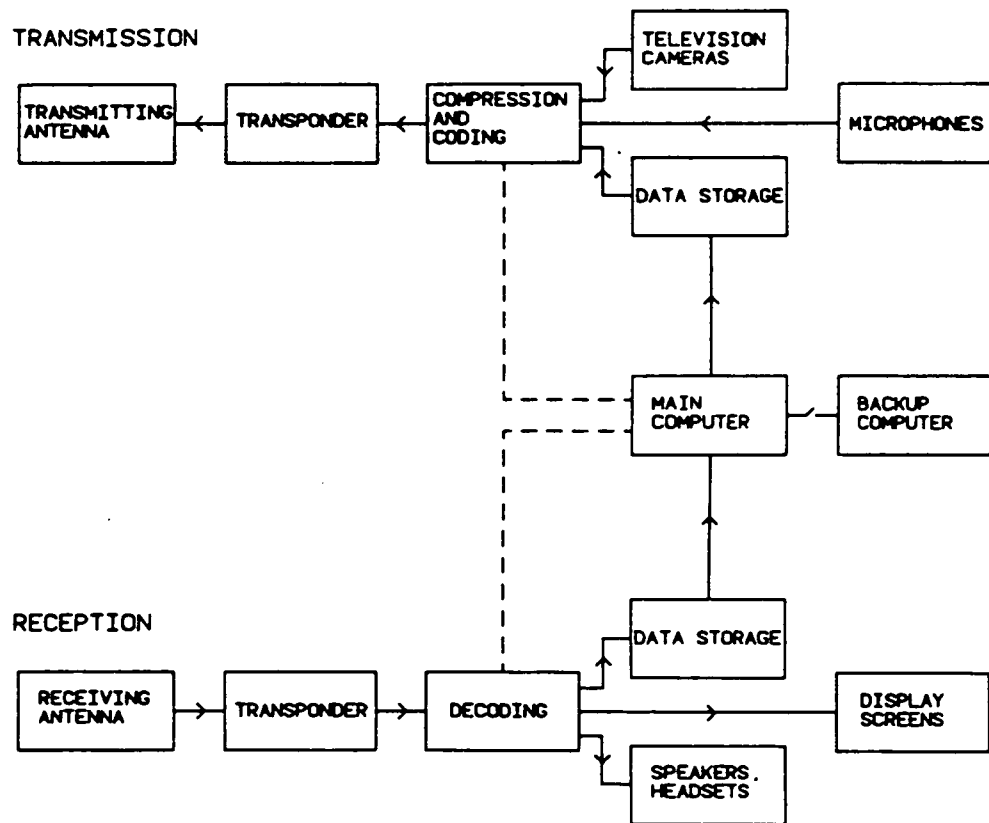

Figure 5-2: Communications System

5.1.2 EVA Communication

The PLR occupants use S-band to communicate with crew doing EVA work. S-band is technically simple and well-suited for short-range voice communication. The transponder operates through an omnidirectional 0.1 m whip antenna mounted on the rover exterior.

5.1.3 Communications Summary

The entire communications system weighs 25 kg, and has a maximum power output of 10 W operating on a 125 V AC source. The EVA transponder has dimensions of 0.1 X 0.1 X 0.1 m (Ref. 49). The two long-range transponders each occupy a space measuring 0.3 X 0.3 X 0.4 m (Ref. 48). The transponders are installed under the floor of the rover (Fig. 5-3). The transponders rarely operate at maximum power, since most signals are sent to one of the lunar satellites. If a satellite malfunctions, the transmitters have sufficient power to transmit directly to Earth satellites. This capability is crucial, since it allows the PLR to operate independently of the lunar satellites under many circumstances.

5.2 NAVIGATION

To effectively perform its mission and return to the lunar base, the PLR accurately tracks its position on the moon. A navigational system is obviously required to perform these duties. The system must not only give the rover's present location, but also assist the crew in negotiating the terrain.

5.2.2 Lunar Navigation

The heart of the PLR navigational system is the inertial measurement unit. This works by measuring the rotation and acceleration in all three dimensions. Traditional gimballed systems are large, heavy, and inefficient (Ref. 51). A strapdown system was chosen to reduce the size, weight, and mechanical complexity of the unit. This type of system is fixed to the body of the PLR. The computer is used to resolve the output into an inertial frame. The strapdown system consists of three laser gyroscopes and three accelerometers. The laser gyroscopes are superior to the mechanical type in that they are insensitive to vehicle vibration, have fewer moving parts, and require less power (Ref. 51).

A problem with inertial measurement systems is that the position error increases over time. During a typical PLR mission, the error becomes so large as to be intolerable. Some sort of correction is needed. Two star mappers mounted on the exterior of the rover periodically correct the position. These work by recording the position of certain stars in view, and comparing these with star maps stored in memory. The spacecrafts inertial position can then be determined.

The computer receives data from both the inertial measurement unit and the star sensor. The computer then compares the data, resolves errors, and outputs the PLR position (Fig. 5-4).

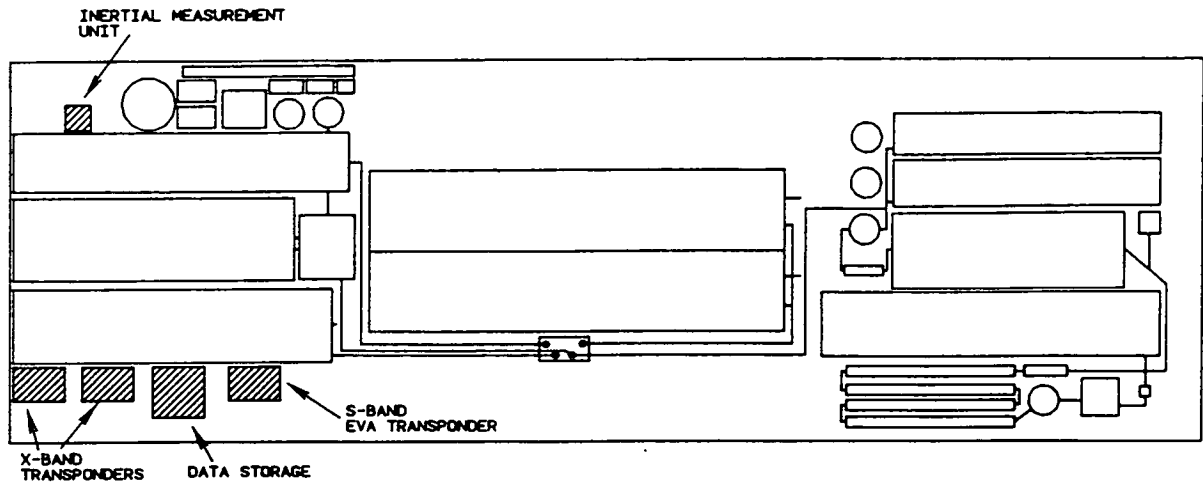

Figure 5-3: Underfloor Electronics Layout

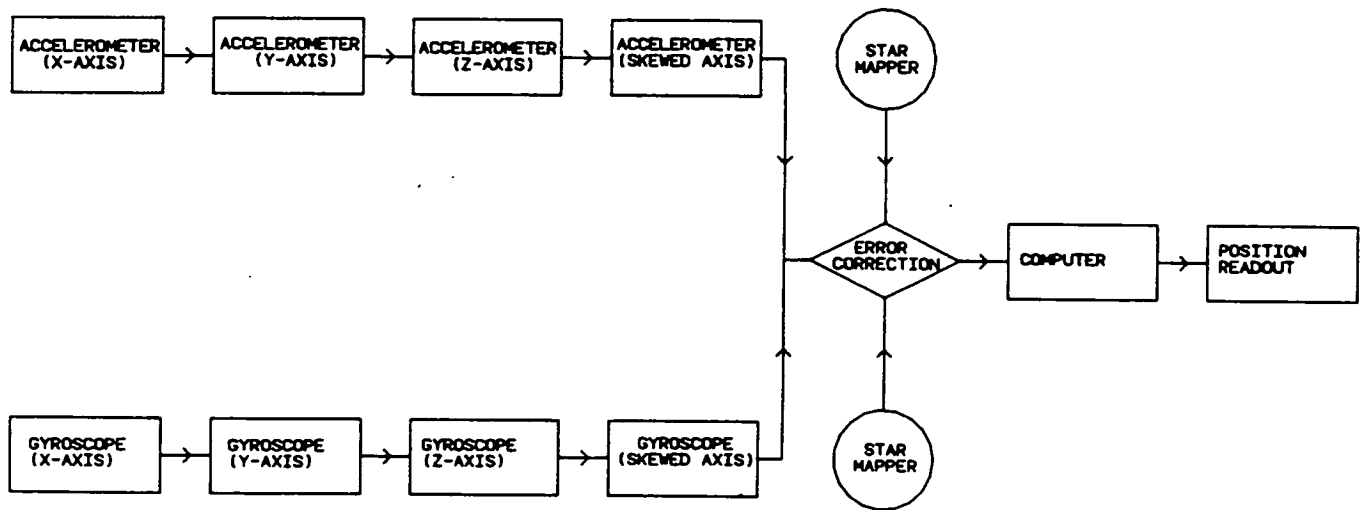

Figure 5-4: Navigation System

5.2.3 Local Navigation

Four cameras mounted on the PLR exterior provide information on the local terrain (Fig 5-5). Servo mounts allow the cameras to swivel. The rover occupants direct the cameras towards areas of interest. The camera views are displayed in both the command center and the lab area.

The rover also has a laser rangefinder assembly mounted on top of the PLR. This mechanism is used to determine the distance of objects, and with the aid of a computer, a rough topological map can be generated. This aids the astronauts in driving the rover across the lunar surface.

5.2.3 Navigation Summary

The entire navigational system weighs 35 kg and consumes 80 W of power (Ref. 48). The star sensors are mounted on the outside of the PLR in a such a position to give a unobstructed view of the sky. The inertial measurement unit is mounted inside the rover under the floor (Fig. 5-3). The laser rangefinder will be mounted towards the front of the rover in a position that will allow it to scan the oncoming terrain.

5.3 PLR COMPUTER

The PLR computer is a vital part of many of the vehicle systems. Almost all of the electrical systems within the rover depend on the computer for monitoring and control (Fig. 5-6). In addition to these demands, the crew also utilizes the computer for various projects and for personal use. The computer must have multi-tasking capability to

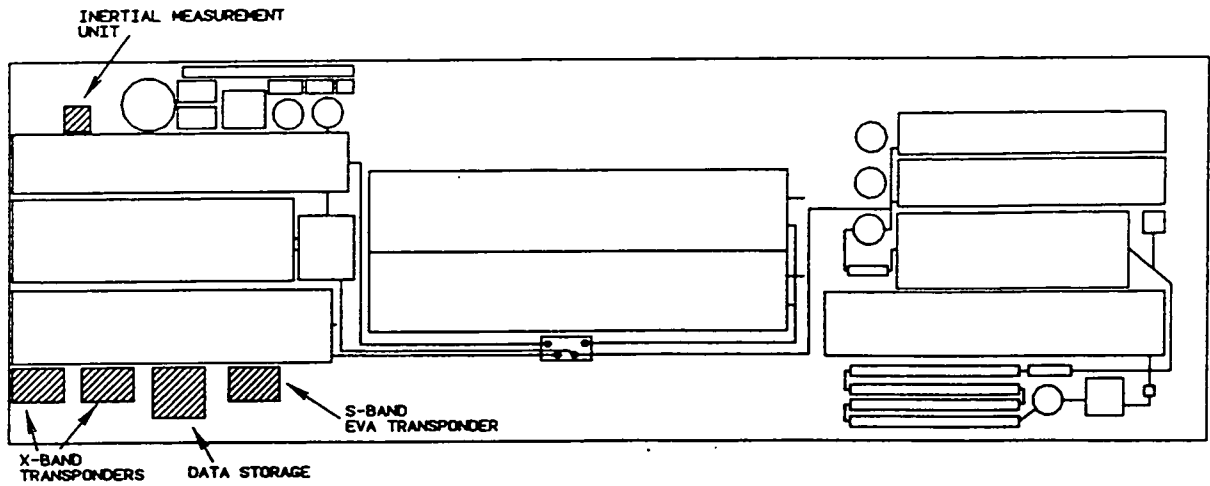

Figure 5-3: Underfloor Electronics Layout

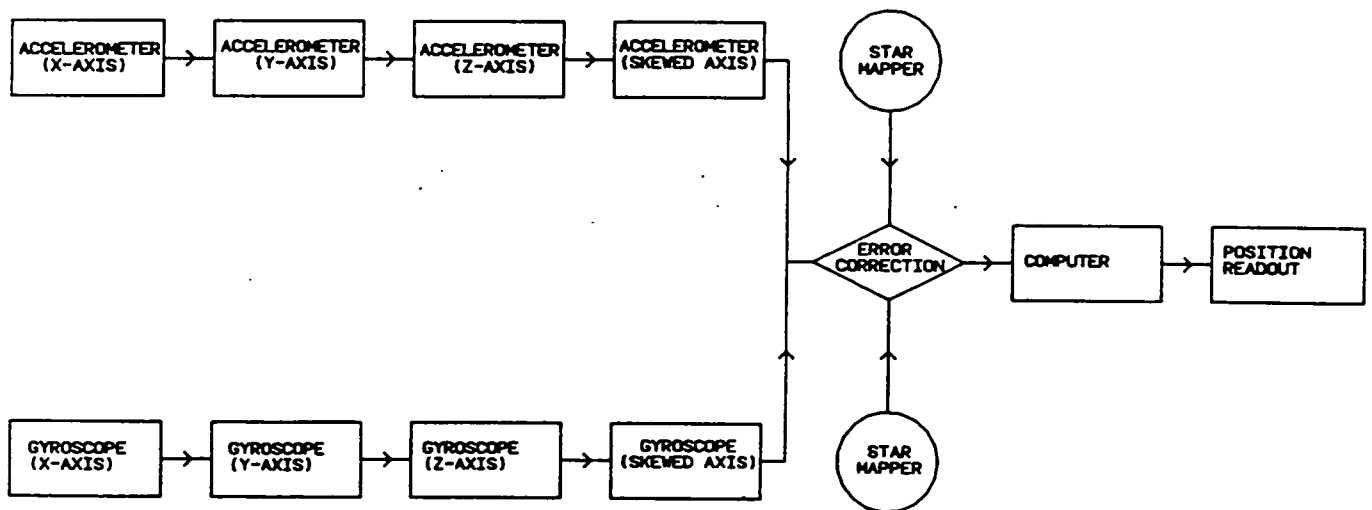

Figure 5-4: Navigation System

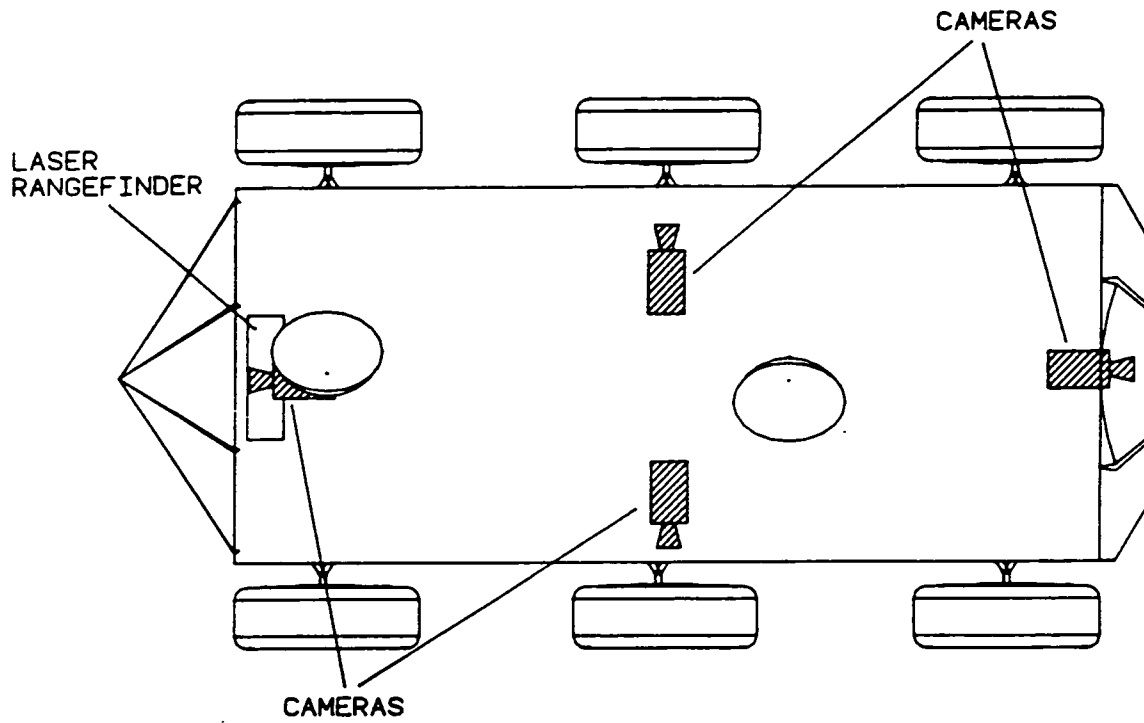

Figure 5-5: Camera Placement

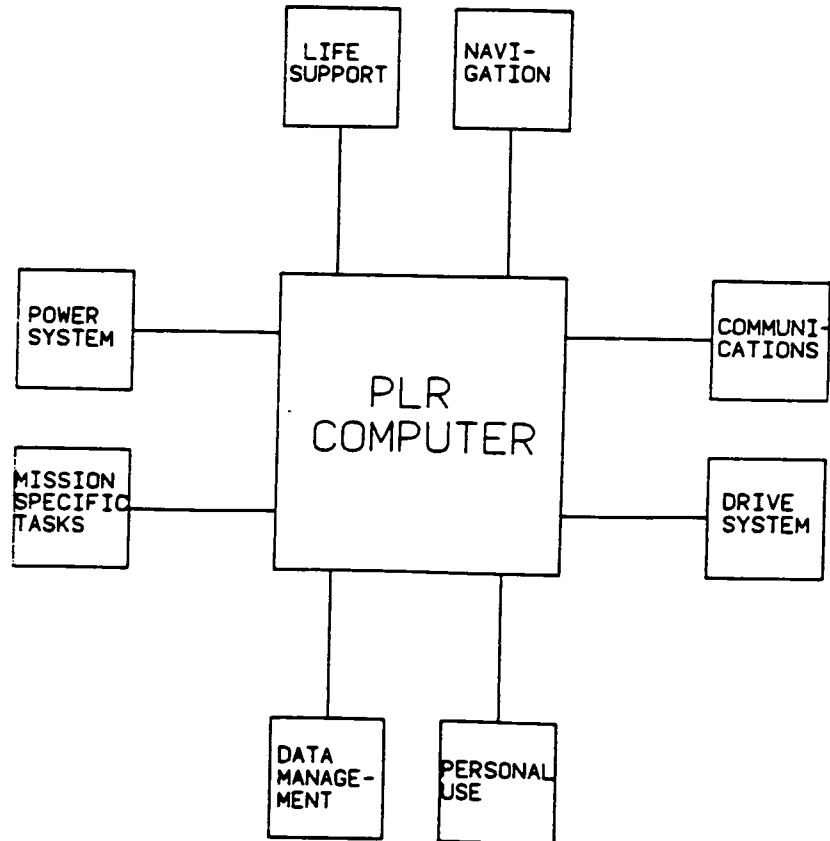

Figure 5-6: Computer System

allow it to perform its duties. A data storage system is required to contain the large amount of information pertaining to the rover's operation.

A computer meeting the needs of the rover is similar to Earth-based "mini-computers". The system weighs 25 kg and draws 200 W of power (Ref. 48). The system occupies about 0.1 X 0.3 X 0.4 m. A backup computer is also carried aboard the rover in case of primary computer failure. This emergency system is only capable of maintaining the basic needs of the rover while it returns to base. The primary computer is installed above the floor in the command center. This location allows easy access for repairs and system checks. The backup computer is stored in the ceiling of the rover (Fig. 5-7). It operates from that location.

Problems too large to be solved by the on-board computer are sent to Earth via the data link. After calculation on Earth, the solution is sent back.

A solid-state data storage system is used for information storage and retrieval. A solid-state system lowers the possibility of mechanical failure and increases system reliability. The data storage system is mounted under the floor of the PLR (Fig. 5-3).

5.4 CONTROL SYSTEM

The controls for the rover electronics are centrally located. The control system functions through the the PLR computer (Fig. 5-8). The computer interprets data from

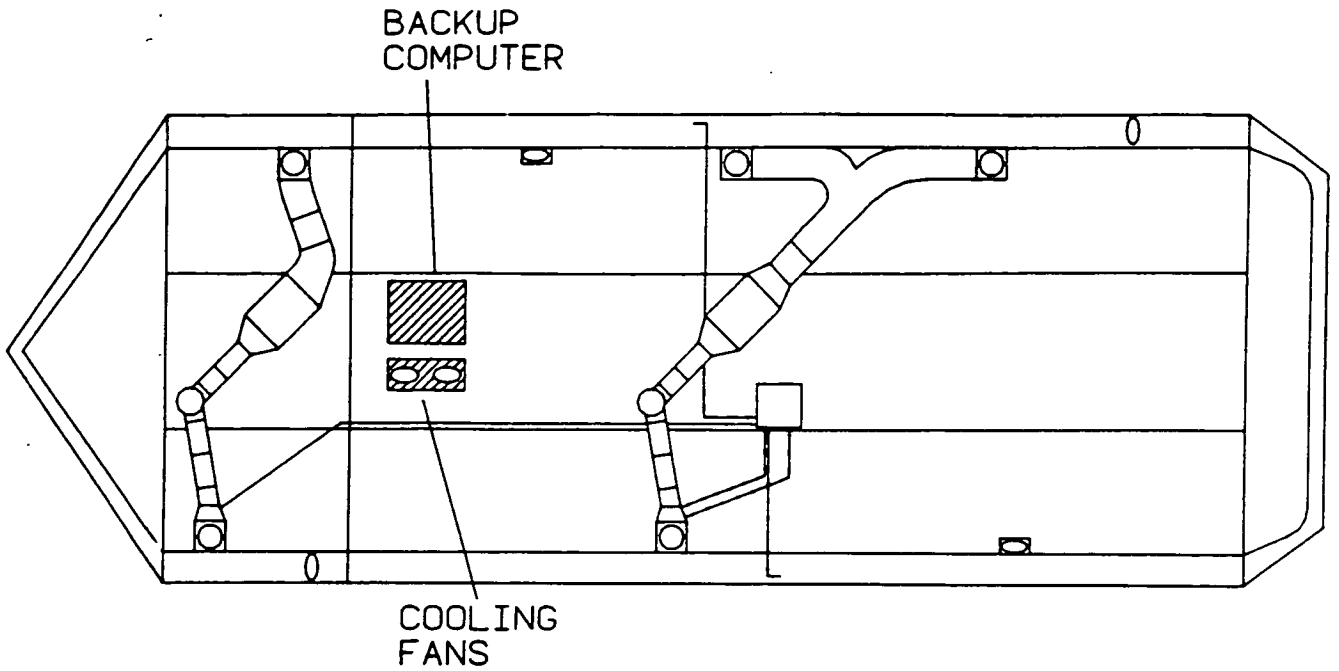

Figure 5-7: Ceiling Computer Layout

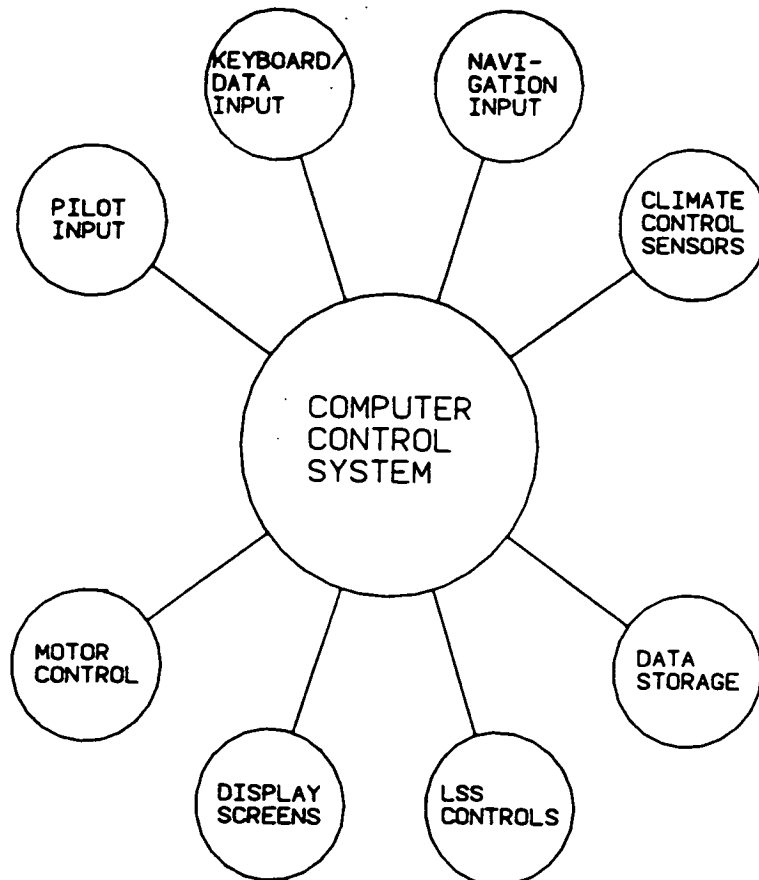

Figure 5-8: Control System

system sensors, and displays the pertinent information. Much of the control system is autonomous, only needing the crew's attention if a situation out of the ordinary should occur. A bank of display screens is used interchangeably to show camera, computer, and navigation outputs. Flat-screen technology is utilized to reduce the size and weight of the screens. Keyboards provide computer control. Dial controls allow manipulation of the cameras.

5.5 ELECTRONICS SYSTEM SUMMARY

TABLE 5-1: Electronics System Specifications

Component	Mass(kg)	Power(W)	Dimensions (m)
Transponder(2)	10	10	0.1 X 0.2 X 0.3
EVA Transponder	3	1	0.1 X 0.1 X 0.1
Parabolic Ant.(2)	25	0	1.0 diameter
EVA Antenna	0.5	0	0.8 long
IMU	10	50	0.1 X 0.1 X 0.1
Star Sensor	5	10	0.1 X 0.1 X 0.2
Laser Rangefinder	20	40	0.1 X 0.3 X 0.3
Cameras(4)	30	20	0.15 X 0.15 X 0.3
Main Computer	20	200	0.2 X 0.4 X 0.4
Backup Computer	15	100	0.2 X 0.3 X 0.3
Data Storage	8	3	0.2 X 0.3 X 0.2
Display Screens(4)	60	60	0.1 X 0.4 X 0.4
Control System	150	50	n.a.
Total:	356.5	544	

6.0 Conclusion

Using the principles of simplicity, versatility, and reliability, a PLR was designed that adheres to the requirements set forth by NASA. The rover is fully capable of meeting the needs of the lunar occupants and performing the many tasks required for the exploration of the moon.

The design of the rover resulted in a two-piece vehicle. A large pressurized cylindrical body houses the equipment and crew living space. This six-wheeled body tows a two-wheeled trailer which contains the power source in the form of an RTG. This configuration gives the PLR added versatility.

Minimizing weight was a primary objective in the design of the PLR. Composites are used throughout the rover to achieve this goal. The weight summary of the PLR is given in Table 6-1.

The rover is driven by six motors mounted in the wheels. This design offers versatility and performance. The performance characteristics of the PLR are shown in Table 6.2.

The internal systems of the PLR include life support, electronics, and controls. These systems allow the crew to perform their mission while insuring their safety. The internal layout of the rover is designed to be functional and pleasing to the lunar astronauts.

The PLR is an effective tool for lunar exploration. Its design allows it to perform a variety of tasks safely and effectively. The rover can easily meet the demands placed upon it by the space program.

TABLE 6-1: Mass Summary (all masses in kg)

body	
shell	500
suspension	102
wheels	240
motors	122
gear units	60
controllers	68
<hr/>	
<u>interior</u>	
walls, dividers, floor	490
<hr/>	
life support	
water requirements	388
food	112
oxygen	177
equipment	813
Total life support system (full load):	1490
<hr/>	
power system	
RTG	1000
batteries	200
wiring system	150
radiator system	150
Total power system:	1500
<hr/>	
shielding	
water shielding	400
foil shielding	20
<hr/>	
electronics	
computer(s)	35
monitors	60
transponders	13
data storage	8
antenna(s)	25
control system	150
GN&C	65
Total Electronics System Mass:	356
<hr/>	
other weights	
occupants	300
external equipment	250
EVA suits	65
trailer body	150
<hr/>	
<u>TOTAL PLR MASS:</u>	6113

TABLE 6-2: PLR PERFORMANCE CHARACTERISTICS

Top speed -----	18 km/hr
Nominal speed -----	10 km/hr
Maximum climbable incline -----	35 deg.
Turn radius -----	7 meters
Ground clearance -----	0.85 meters
Maximum output power -----	9.5 kw
Nominal output power -----	6.5 kw
Range (lunar day, @ 18 km/hr) -----	3192 km radius
Range (lunar day, @ 10 km/hr) -----	1680 km radius
Range (lunar night, @ 18 km/hr) -----	3192 km radius
Range (lunar night, @ 10 km/hr) -----	1680 km radius
Towing capacity (@ 6 km/hr, 30 deg.) -----	4.2 metric tons

REFERENCES

- 1 Chuck Chandler, Composite Materials Specialist, Virginia Tech Composites Lab, Interview 1992
- 2 Ageikin, IA.S. Off-The-Road Mobility of Automobiles, Washington D.C., Amerind Pub. Co., 1987.
- 3 Inland Motor: Kollmorgen Corporation. Brushless D.C. Motors and Servo Amplifiers, Revision 1. Radford, Virginia: 1990.
- 4 Globe Motors: Labinal Components and Systems, Inc. Product Catalog M-100. Dayton, Ohio: 1991.
- 5 Inertial Motors Corporation. D.C. Servo Motors and Amplifiers. Doylestown, Pennsylvania: 1991.
- 6 Industrial Drives: Kollmorgen Corporation. Motion Control Products. Radford, Virginia: 1991.
- 7 Andreas, John C. Energy Efficient Electric Motors. New York, New York: Marcel Dekker, Inc., 1982.
- 8 Cengel, Yunus A. and Boles, Michael A. Thermodynamics An Engineering Approach. New York: McGraw Hill, Inc., 1989.
- 9 Inland Motor: Kollmorgen Corporation. Brushless D.C. Motor Application Notes, Revision 1. Radford, Virginia: 1989.
- 10 Beer, F.P. and Johnston, E.R. Mechanics Of Materials. New York: McGraw-Hill, Inc., 1981
- 11 Hickman, J.M. and Bloomfield, H.S. "Comparison of Solar Photovoltaic and Nuclear Reactor Power Systems For a Human-tended Lunar Ovsevatory." NASA document N89-23397
- 12 Determan, W.R. and Harty, R.B. "DIPS Spacecraft Integration Issues."
- 13 Bailey, Patrick G. "A Comparison of 5-30 KWE space Nuclear Power Systems and Associated Requirements."
- 14 Cengel, Yunus A and Boles, Michael A. Thermodynamics an Engineering Approach. New York: McGraw-Hill, Inc., 1989.
- 15 Sievers, R.k. "Radioisotope Powered Alkali Metal Thermoelectric Converter design for Space Systems."
- 16 Hartman, Robert F. "Current Satus of Mod-RTG Program."
- 17 Heshmatpour, B. "Fabrication of Advanced Technology Silicon Germanium Thermoelectric Devices."

- 18 Scaringe, R. P., J. A. Buckman, and L. R. Grzyll
"Investigation of Advanced Heat Pump Augmented Spacecraft
Heat Rejection Systems."
- 19 Levy, E. Jr. "U.S. Air Force Design Nickel-Hydrogen Cells -
Flight Status and Recent Improvements."
- 20 Dagarin, B.P. "Galileo Probe Battery Systems Design."
- 21 Eagle Engineering. "Maintenance and Supply Options." NASA
Document N88-29837.
- 22 NASA Document N89-18983.
- 23 Ferro, Claudio, and Antonio Moscatelli. "Hermes Thermal
Control Subsystem--Design Concepts." SAE Report 90-1365.
- 24 Rothmeyer, Markus, Antonius Winkeljiann, and Werner
Hofacker. "Thermal Analysis for the Habitable Volumes of
HERMES." SAE Report 89-1520.
- 25 Hienerwadel, K. O., and G. Kring. "Design of the
Environmental Control and Life Support Systems for the
Columbus Pressurized Modules." SAE Report 90-1531.
- 26 Scaringe, R. P., J. A. Buckman, L. R. Grzyll, E. T. Mahefkey,
and J .E. Leland. "Investigation of Advanced Heat Pump
Augmented Spacecraft Heat Rejection Systems." AIAA 89-0072.
- 27 Solar Energy Information Services. Thermal Energy Storage:
Design and Installation Manual. Revised 2nd ed. Sacramento,
CA: Solar Energy Information Services, 1981.
- 28 Petter, Frederich, and Christine Planert. "Condensing Heat
Exchangers as Main Components in LSS for Manned Spacecraft."
SAE Report 90-1284.
- 29 Roberts, B. C., R. L. Carrasquillo, M. Y. DuBiel, K. Y. Ogle,
J. L. Perry, and K. M. Whitley. "Phase III Simplified
Integrated Test Detailed Report." NASA Document N90-22593.
- 30 Aerospace Medicine. Sept. 1968, p. 937.
- 31 Phone conversation with J. L. Perry, George C. Marshall
Space Flight Center, Huntsville, AL.
- 32 Abele, Hermann, Klaus Ammann, and Jochen Franzen.
"Atmosphere Trace Gas Contamination Management for the
Columbus Pressurized Modules." SAE Report 90-1288.
- 33 Phone conversation with Dr. Kingston, Chemistry Department,
Virginia Polytechnic Institute and State University.

- 34 Hienerwadel, K. O., and S. Rainer. "Evaluation of the Suitability of CO Measurement for Fire Detection in Space." SAE Report 90-1285.
- 35 Phone conversations with Gerald V. Colombo, Umpqua Research Company, Myrtle Creek, OR.
- 36 Putnam, David F., and Gerald V. Colombo. "Pre- and Posttreatment Techniques for Spacecraft Recovery Water." NASA Document N87-25766.
- 37 Putnam, David F., Clifford D. Jolly, Gerald V. Colombo, and Don Price. "Recovery of Hygiene Water by Multifiltration." SAE Report 89-1445.
- 38 Bourland, Charles T., Michael Fohey, Vickie Kloeris, and Rita Rapp. "Designing a Food System for Space Station Freedom." Food Technology. Feb. 1989, pp. 76-81.
- 39 Sears Catalog. Sears, Roebuck, and Co. Spring 1991.
- 40 Traxler, Gerhard. "The Development of the Human Waste Collection Assembly for HERMES." SAE Report 90-1287.
- 41 The New Encyclopedia Britianica. 15th ed, Chicago, 1988.
- 42 Kutner, Marc L., Astronomy. A Physical Perspective. John Wiley & Sons, Toronto, 1987.
- 43 Wertz, John R. and Wiley J. Larson. Space Mission Analysis and Design. Kluwer Academic Publishing, Boston, 1991.
- 44 Raznjecvik, Kuzman. Handbook of Thermodynamic Tables and Charts. Hemisphere Publishing Corp., St. Louis, 1989.
- 45 Beaton, C. F. and G.F. Hewitt. Physical Property Data for the Design Engineer. Hemisphere Publishing Corp. Philadelphia, 1989.
- 46 McGraw-Hill Encyclopedia of Science and Technology. 6th ed., St. Louis, 1987.
- 47 Ponchak, D., Zurek, J, Whyte, W., Spence, R., and Sohn, P. "A Technology Assessment of Alternative Communications Systems for the Space Exploration Initiative. NASA Document N90-27736.
- 48 Space Mission Design and Analysis.
- 49 Conversation with Charles Moses, Virginia Polytechnic Institute and State University.
- 50 "Spacecraft Telemetry Mass Estimates" NASA Document N88-18784.

- 51 Linkwitz, K., and Hangleiter, U. High Precision Navigation. Springer-Verlag, 1989.
- 52 Conversation with N. Kirchbaum, Department of Aerospace and Ocean Engineering, Virginia Polytechnic Institute and State University.
- 53 Koelle, H. H. Handbook of Astronautical Engineering. McGraw-Hill Book Company, 1961.
- 54 "Mars Manned Transportation Vehicle" NASA Document N89-20545.
- 55 NASA Document N89-20545.
- 56 NASA Document N90-26332.
- 57 Seifert, H. S. Space Technology. Chapman and Hall Limited, 1959.
- 58 "U.S. Planetary Rover Status: 1989" NASA Document N90-25353.

APPENDIX 2-1: CALCULATIONS

Differential speed steering calculations:

u = friction coefficient..... 0.5
 W = weight of PLR..... 6000 kg
 g_m = moons acceleration..... 1.635 m/s²
 r = wheel radius..... 0.75 m
 F = frictional force per tire
 f = force required per tire
 T = torque required per tire

$$F = u*(W*g_m)/36 = 817.5 \text{ N}$$

$$2*f + 2*f*\cos 26 + 2*f*\cos 63 = 4*F$$

$$4.7*f = 3270 \text{ N}$$

$$f = 695 \text{ N}$$

$$T = f*r = 695 * .75$$

$$T = 521 \text{ N*m}$$

APPENDIX 2-2: MOTOR CALCULATIONS

Constants:	mass(m)	=	6200 kg
	weight(w)	=	10137 N
	wheel radius(r)	=	0.75 m
	rolling resistance coeff.(p)	=	0.18
	angle of slope(a)	=	5° to 30°
	torque sensitivity(K _T) of 12901	=	4.75 N-m/amp
	" " of 06202	=	1.34 N-m/amp
	back EMF constant(K _B) of 12901	=	4.75 V/rad/s
	" " " of 06202	=	1.34 V/rad/s

Formulas: Torque(T_{wheel}) = [w*r*cos(a)*(p+tan(a))/6] N-m
 Resistive Force(F_{wheel}) = [T_{wheel}/r] N
 Voltage(V) = K_B*speed(rad/s) V
 Current(I) = T_{output}*(1/K_T) A
 Power(P_{wheel}) = Voltage * Current

Sample Calculations: RBE-06202-B50 Motor, 0° incline, 10 km/hr

T_{wheel} = 10137*0.75*cos(0)*(0.18+tan(0))/6
 T_{wheel} = 228.08 N-m
 F_{wheel} = 228.08/.75
 F_{wheel} = 304.11 N
 Voltage = 1.34*1097*2*3.1416/60
 Voltage = 153.9 V
 Current = 5.37*1/1.34
 Current = 4 A
 P_{wheel} = 153.9 * 4
 P_{wheel} = 0.616 kw

APPENDIX 2-3: MOTOR PERFORMANCE DATA

The BMS-12901 and RBE-06202-B50 motors are compared over varying inclines, torques, and vehicle speeds to determine their voltage, current, and motor speed variations. It must be noted that neither of these two motors are capable of the high torques needed, thus a harmonic gear drive system of the appropriate gear ratio will be used with each motor. Table A and Table B along with the following figures, show the results of those investigations.

TABLE A: Performance of BMS-12901 Motor

----- BMS-12901 DC Brushless Motor w/9.5:1 Gear Reduction System -----						
Incline (deg)	Vehicle speed (km/hr)	Motor torque (N-m)	Wheel speed (rpm)	Motor speed (rpm)	Voltage (Volts)	Current (Amps)

30	4	89	14.15	135	67.2	18.6
	6	89	21.22	202	100.5	18.6
	8	89	28.29	269	133.8	18.6
	10	89	35.37	336	167.1	18.6
	12	89	42.44	404	201.0	18.6
	14	89	49.52	471	234.3	18.6
	16	89	56.59	538	267.6	18.6

0	4	18	14.15	135	67.2	5.2
	6	18	21.22	202	100.5	5.2
	8	18	28.29	269	133.8	5.2
	10	18	35.37	336	167.1	5.2
	12	18	42.44	404	201.0	5.2
	14	18	49.52	471	234.3	5.2
	16	18	56.59	538	267.6	5.2

TABLE B: Performance of RBE-06202-B50 Motor

RBE-06202-B50 Brushless Motor w/31:1 Gear Reduction System						
Incline (deg)	Vehicle speed (km/hr)	Motor torque (N-m)	Wheel speed (rpm)	Motor speed (rpm)	Voltage (Volts)	Current (Amps)
30	4	26.8	14.15	439	61.6	20.0
	6	26.8	21.22	658	92.3	20.0
	8	26.8	28.29	878	123.2	20.0
	10	26.8	35.37	1097	153.9	20.0
	12	26.8	42.44	1316	184.7	20.0
	14	26.8	49.52	1535	215.4	20.0
	16	26.8	56.59	1754	246.1	20.0
0	18	26.8	63.66	1974	277.0	20.0
	4	7.36	14.15	439	61.6	5.5
	6	7.36	21.22	658	92.3	5.5
	8	7.36	28.29	878	123.2	5.5
	10	7.36	35.37	1097	153.9	5.5
	12	7.36	42.44	1316	184.7	5.5
	14	7.36	49.52	1535	215.4	5.5
16	7.36	56.59	1754	246.1	5.5	
18	7.36	63.66	1974	277.0	5.5	

From the two tables above it can be seen that each of these motors are capable of running at the required nominal speed without drawing more current or voltage than allotted. In fact, they can exceed this speed if the need arises. The RBE-06202-B50 is capable of a slightly higher speed and thus has a slight edge in performance. The following figures illustrate motor requirements and the capabilities for the BMS-12901 and RBE-06202-B50 motors.

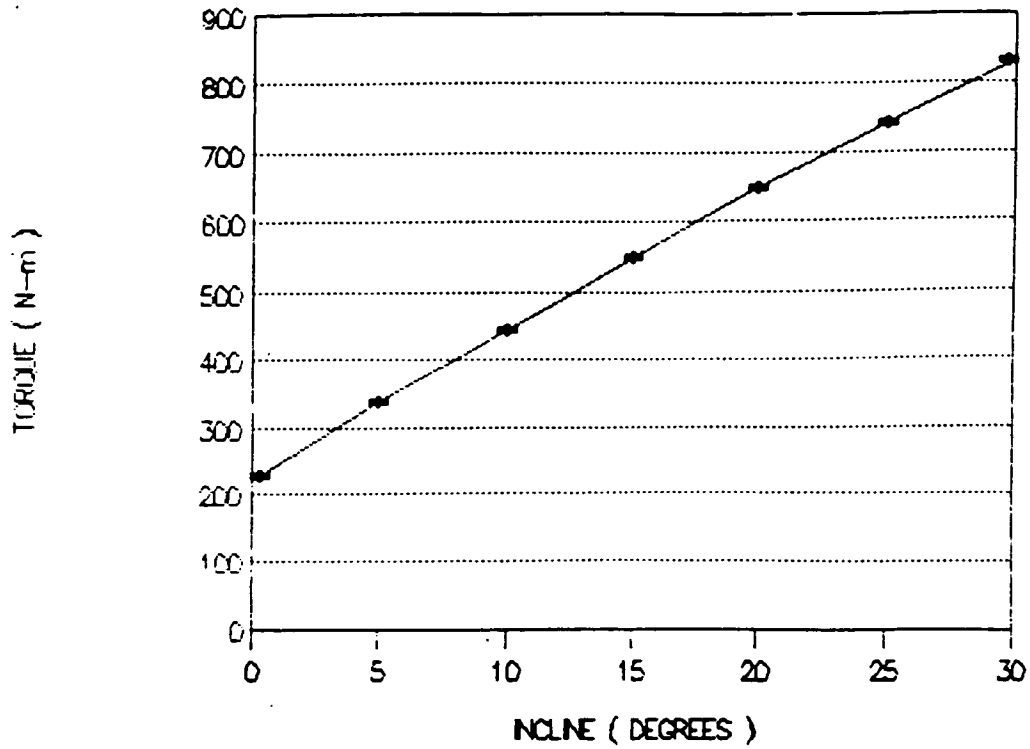

Figure A Torque Required per Wheel For Climbing

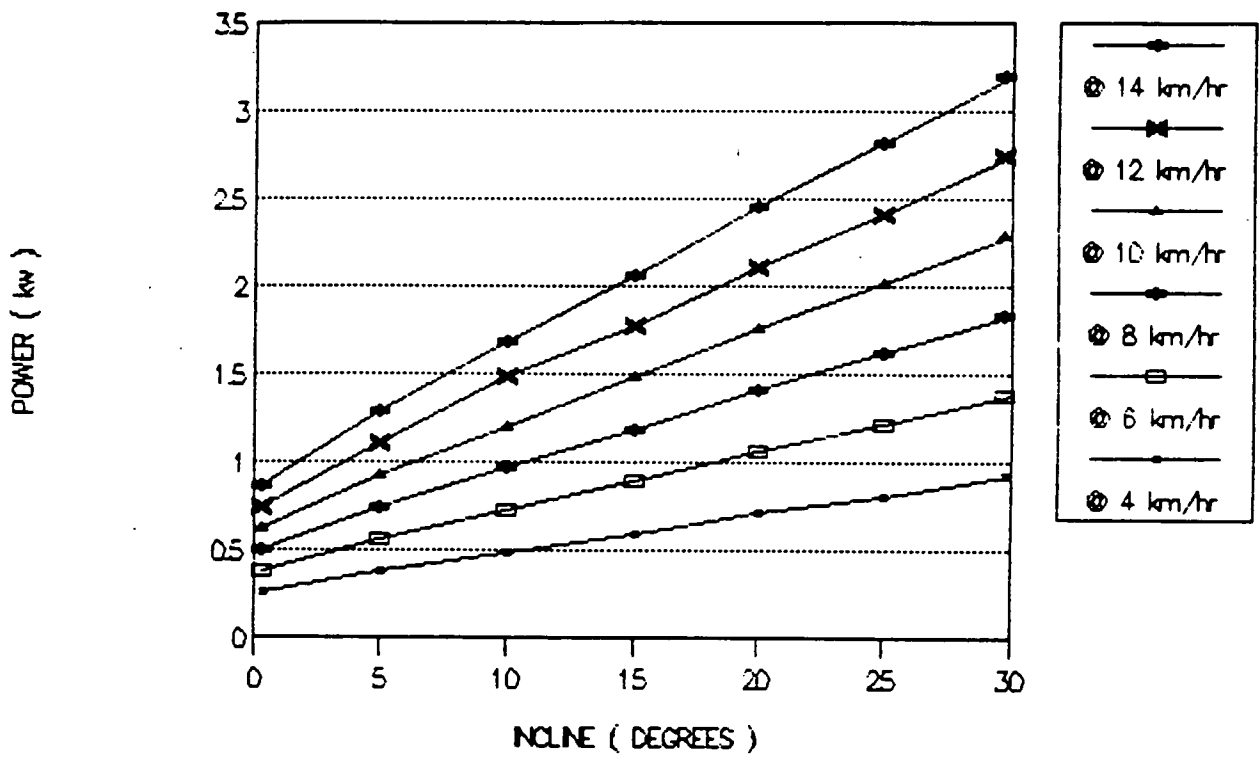

Figure B Power Required For Driving

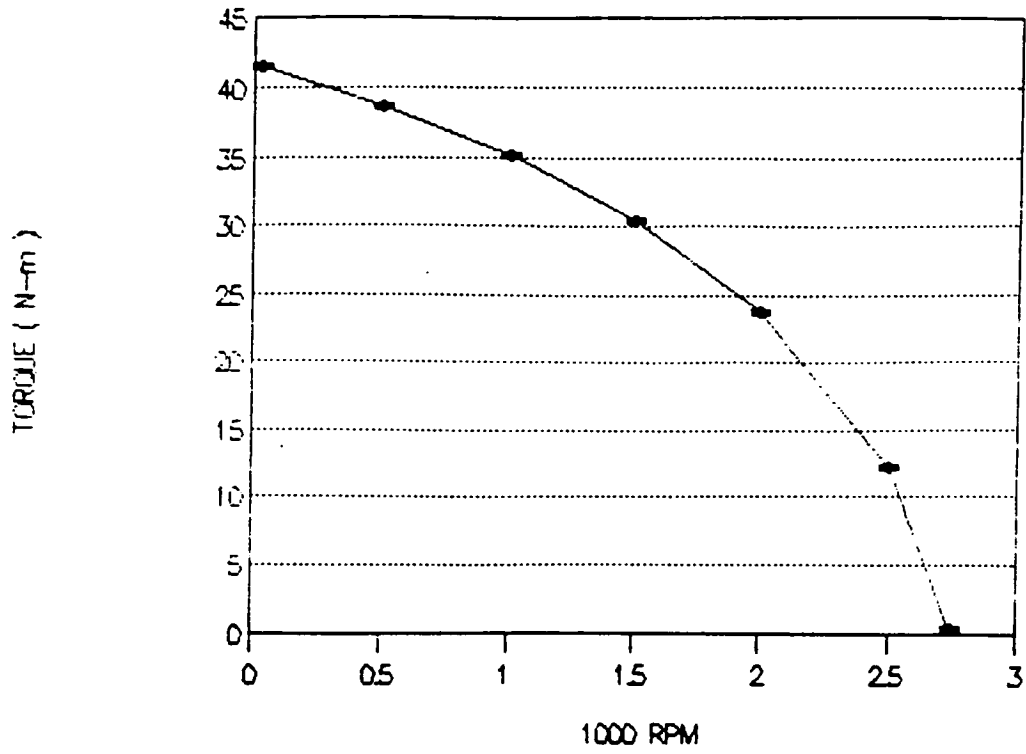

Figure D Continuous Duty Cycle For RBE-06202-B50

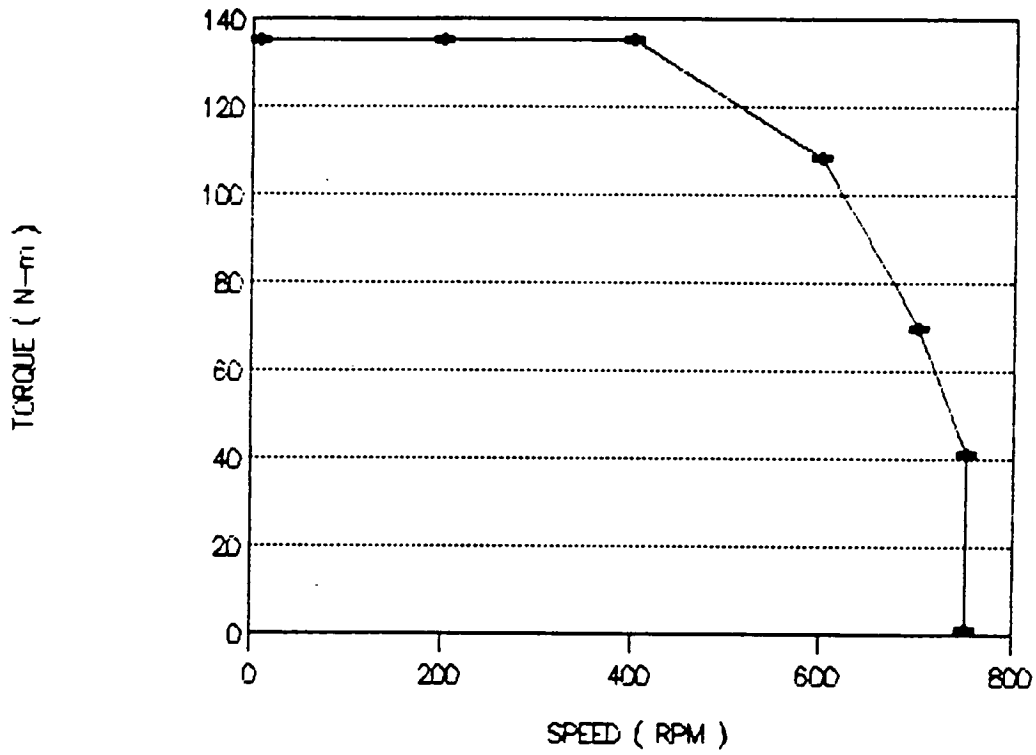
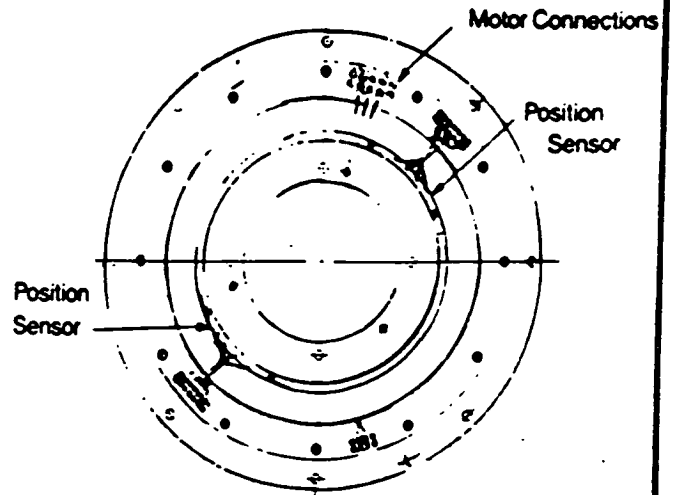
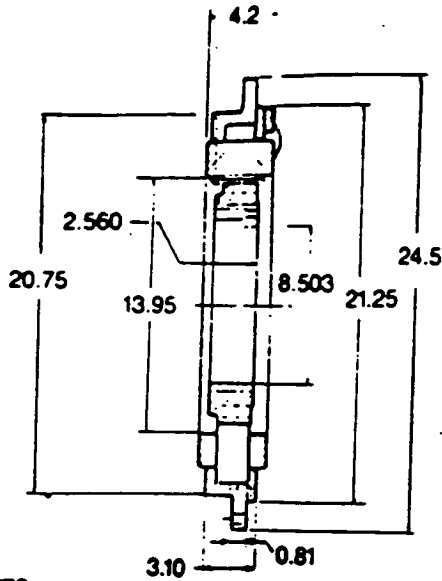

Figure C Continuous Duty Cycle For BMS-12901

From the required torque curve and the continuous duty cycles for each motor it can be seen that each motor is capable of reaching the torque required. The BMS-12901 must use a 9.5:1 gear ratio and the RBE-06202-B50 must use a 31:1 gear ratio. Appendix 2-2 above shows the equations used in calculating the performance parameters.



NOTES:

- 1 MOTOR SHIPPED FULLY ASSEMBLED WITH SHIPPING CLAMPS IN PLACE AND SHIMS IN AIR GAP. CAUTION: REMOVE CLAMPS AND SHIMS BEFORE OPERATING MOTOR.
- 2 CAUTION REQUIRED FOR HANDLING AND MOUNTING. STRONG MAGNETIC FORCES PRESENT

Size Constants	Value	Units
Peak Torque Rating - T_p	100	lb.ft
Power Input, Stalled at T_p (25°C) - P_p	204	watts
Motor Constant - K_M	7.00	lb.ft/ $\sqrt{\text{watt}}$
Number of Phases	3	
Electrical Time Constant - τ_e	20.0	ms
Static Friction (Max.) - T_s	2.5	lb.ft
Damping Coefficient Zero Impedance - F_0	66.5	lb.ft per rad/s
Maximum Winding Temperature	155	°C
Temperature Rise per Watt-TPR	0.17	°C/watt
Winding Connection	Delta	
Number of Poles	28	
Rotor Inertia - J_M	0.170	lb.ft.s ²
Motor Weight	160	lb

Recommended Drive Electronics: BLM 2000/BLR 6000

Continuous Operation Curve

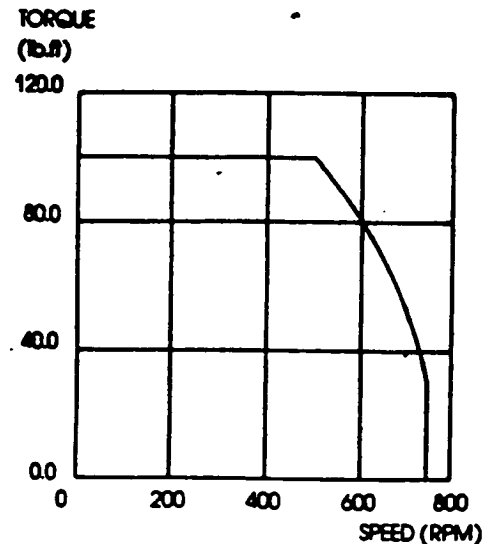

CURVE BASED ON 25 DEGREE C AMBIENT. MOUNTED MOTOR TPR USED.

Winding Constants

Winding Designation

	Units	Tolerances	A	B	C	D	E	F
Voltage, Stalled at T_p (25°C) - V_p	volts	Nom.	7.15					
Peak Current - I_p	amperes	Rated	28.6					
Torque Sensitivity - K_T	lb.ft/amp	± 10%	3.50					
Back EMF Constant - K_e	V per rad/s	± 10%	4.75					
DC Resistance (25°C) - R_M	ohms	± 10%	0.25					
Inductance - L_M	mH	± 30%	5.0					

Housed Motor

MODEL	LENGTH
RBE--06202--00	4.550 (115.6)

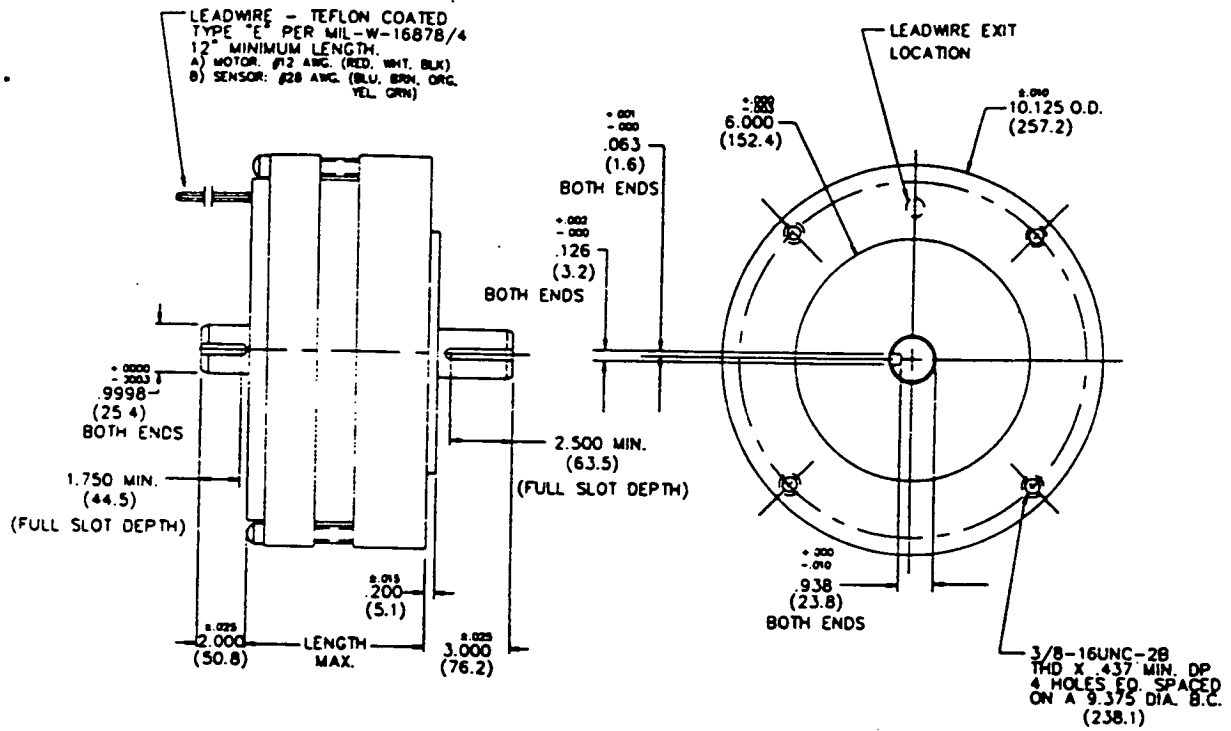

NOTE. DIMENSIONS IN PARENTHESIS REPRESENT MILLIMETERS

High Performance / High Torque
RBE(H) 06200 MOTOR SERIES

SIZE CONSTANTS

PARAMETERS	MODEL NO.	UNITS	RBE-06202-850
Peak Rated Torque, $\pm 25\%$		Fl-lb	173.3
		Nm	234.8
Power at Peak Rated Torque		Kw	5.4
Max. Continuous Stall Torque, T_s		Fl-lb	32.7
		Nm	44.3
Max. Continuous Output Power		Watts	3025
Motor Constant, $\pm 15\%$, K_m		Fl-lb/ \sqrt{W}	2.33
		Nm/ \sqrt{W}	3.15
TPR, $\pm 15\%$ †		(°C/A)	0.37
Viscous Damping, F_v		Fl-lb/RPM	4.0×10^{-4}
		Nm/RPM	5.4×10^{-4}
Hysteresis Drag Torque, T_d		Fl-lb	0.67
		Nm	0.91
Max. Cogging Torque		Fl-lb	0.68
		Nm	0.92
Frameless Motor	Inertia, J_m	Fl-lb-sec ²	11.1×10^{-3}
		Kg-m ²	15.0×10^{-3}
Frameless Motor	Weight	Lb	25.6
		Kg	11.6
Housed Motor	Inertia, J_m	Fl-lb-sec ²	17.1×10^{-3}
		Kg-m ²	23.2×10^{-3}
Housed Motor	Weight	Lb	45.0
		gm	20.4
No. of Poles			12

145 VOLT 'B' WINDING CONSTANTS

Peak Torque, $\pm 25\%$, T_s		Fl-lb	173.3
		Nm	234.8
Peak Current, $\pm 15\%$, I_p		Amps	173
Torque Sensitivity, $\pm 10\%$, K_t		Fl-lb/Amp	1.0
		Nm/Amp	1.34
No Load Speed, $\pm 10\%$		RPM	1030
Voltage Constant, $\pm 10\%$, K_v		V/Rad/sec	1.34
		V/KRPM	140
Terminal Resistance, $\pm 12\%$, R_m		ohms @ 25°C	0.18
Terminal Inductance, $\pm 30\%$, L_m		mH	1.7
Max. Continuous Output Power	Power	Watts	3020
	Torque	Fl-lb	21.5
		Nm	29.1
Speed	RPM	990	

C-2

Servo Amplifiers
MODEL NUMBER BLR-9000

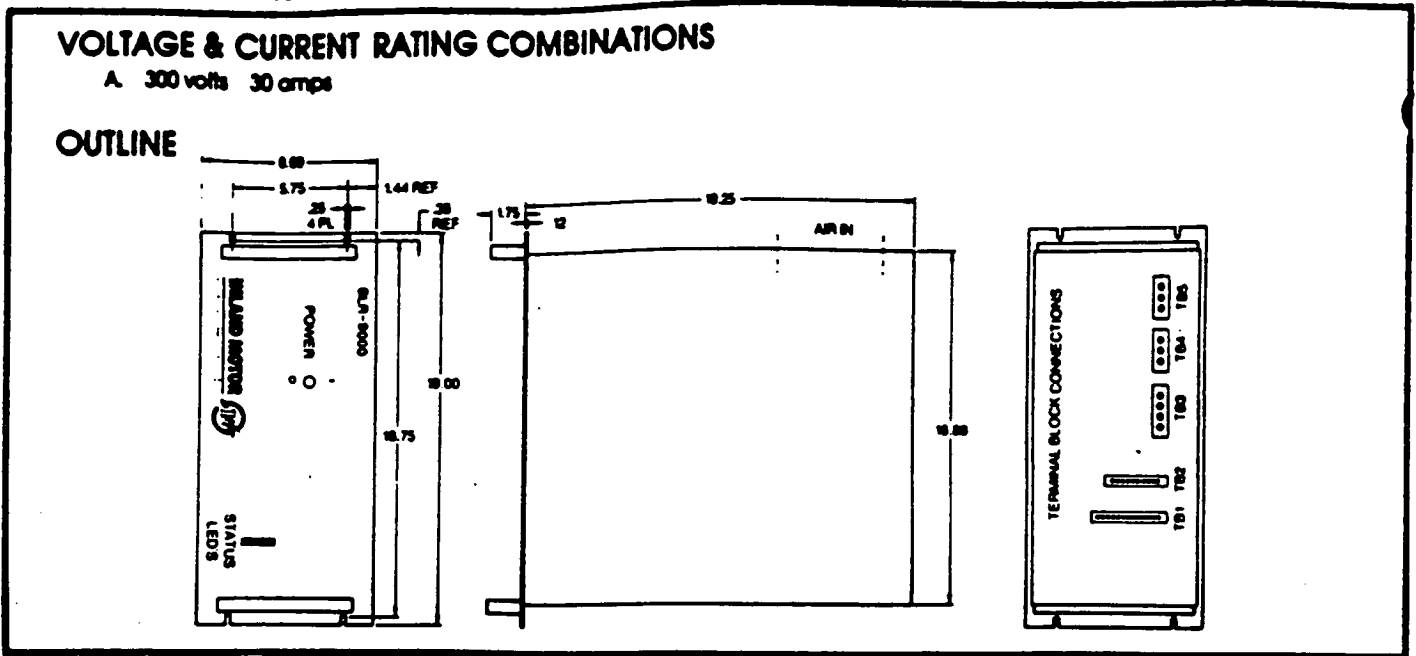

FEATURES

- Current Loop Operation
- Velocity Loop Operation with Tachometer, Hall Devices, or Encoder
- Frequency Locked Loop Operation
- 20 KHz PWM Frequency
- Status Indicators for Over-temperature and Over-current
- Logical Enable
- Fault Logic
- 19" Rack Mount
- Greater than 90% Efficient
- Four Quadrant Operation
- Integral Power Supply
- Regeneration Protection

SPECIFICATIONS

POWER OUTPUT

	A 300 volts/30 amps
MAX VOLTS	300
AMPS CONT.	30
AMPS PEAK	30
WATTS CONT.	9000
WATTS PEAK	9000

POWER INPUT

BUS VOLTAGE	220 VAC 50/60 Hz
CURRENT	0-48 A
CONTROL VOLTAGE	None Req'd.
CURRENT	None Req'd.

LOAD

MIN. INDUCTANCE	1 mH
-----------------	------

MECHANICAL

SIZE	19" w x 8.7" h x 1 9/16" d
WEIGHT	25 lb
SIGNAL CONNECTOR	Term. Strips
POWER CONNECTOR	Term. Strips

**COMMUTATION: Six Sequence or Sinusoidal
 CONTROL CONFIGURATIONS**

	COMMAND INPUT	EXTERNAL FEEDBACK	ADJUSTMENTS
CURRENT LOOP	±10V	(NONE)	Command Scaling
VELOCITY LOOP (BRUSH TACH)	±10V	Brush Tach	Command Scaling, DC Offset Feedback Scaling, AC Gain Current Limit
VELOCITY LOOP (BRUSHLESS TACH)	±10V	Brushless Tach	Command Scaling, DC Offset Feedback Scaling, AC Gain Current Limit
VELOCITY LOOP (ENCODER)	±10V	Encoder	Command Scaling, DC Offset Feedback Scaling, AC Gain Current Limit
VELOCITY LOOP (HALL SENSORS)	±10V	Hall Sensors	Command Scaling, DC Offset Feedback Scaling, AC Gain Current Limit
FREQUENCY LOCKED VELOCITY LOOP	Ref. Freq.	Hall Sensors Or Encoder	(Factory Pre-set)

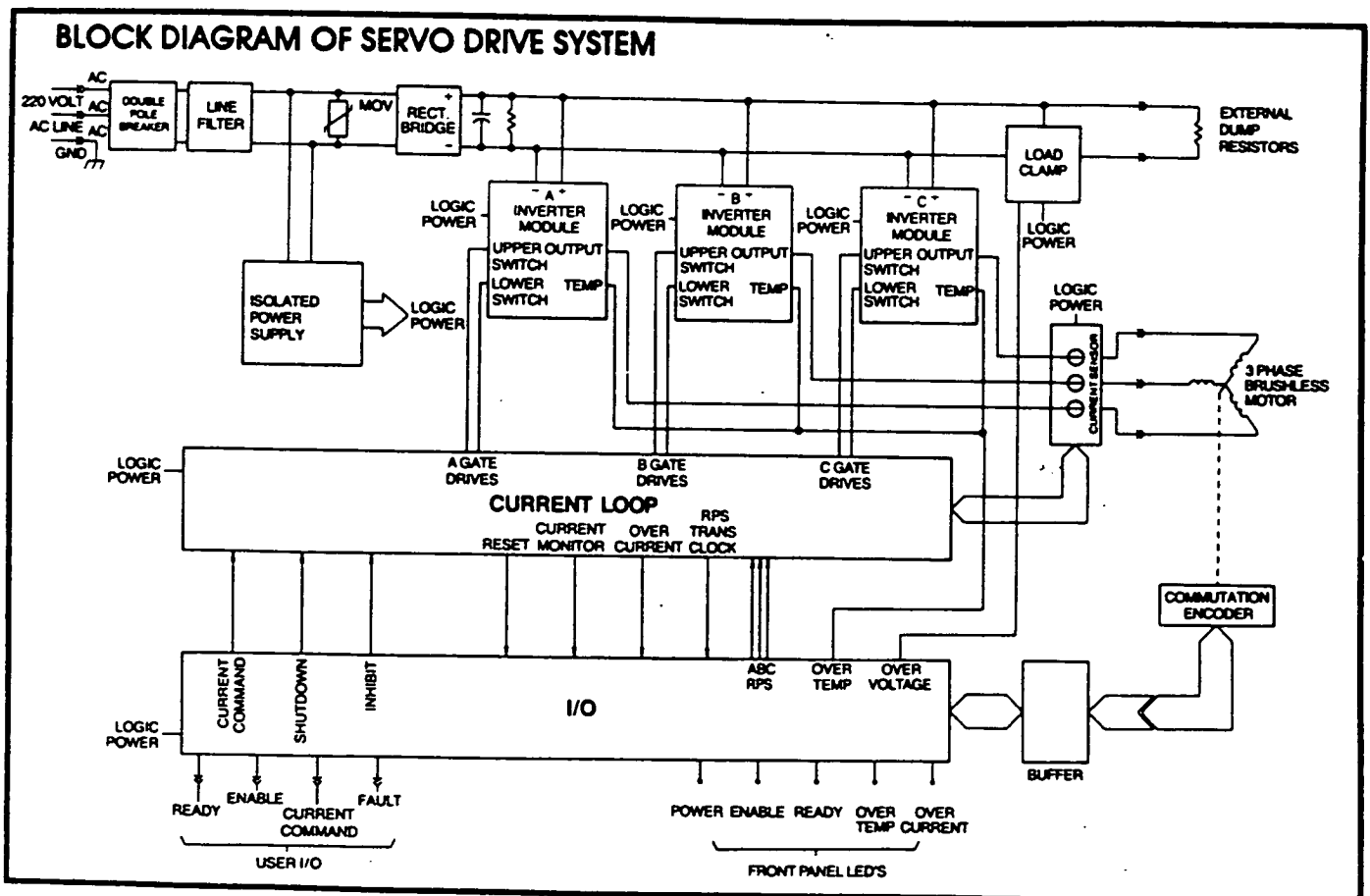

APPENDIX 3.1

** RADIATOR AREA CALCULATIONS (Ref. 18)

$$q = (\epsilon \sigma (T_{\text{rad}}^4 - T_{\text{sink}}^4))$$

where:

- q is the heat flux per unit area (W/m^2)
- σ is the Stefan-Boltzmann constant ($\text{W}/\text{m}^2\text{-K}^4$)
- ϵ is the emissivity of the radiator surface
- T_{rad} is the radiator temperature (K)
- T_{sink} is the effective sink temperature (K)

Using:

$$T_{\text{rad}} = 20 \text{ K}$$

$$T_{\text{sink}} = 1300 \text{ K}$$

$$q = 1.309 \times 10^5$$

using a 1100 kW cooling requirement, radiator area = 8.403 m^2

APPENDIX 3.2

** Excess battery mass calculations for Photovoltaic system

power := 6.7 kW

missionduration := 36 hrs

battery energy density := .3 kW.hrs/kg

Therefore Total battery weight := power $\frac{\text{missionduration}}{\text{density}}$

weight = 804 kg

** Secondary power battery calculations

cell type = L150

cell characteristics

voltage := 1.2 volts at 6.5 amp.hrs

Using $n = \frac{p}{v \cdot i}$

where:

n = number of required cells
p = required power
i = required output current
v = cell voltage

Therefore

p := 3000 watts
i := 30.0 amps
v := 1.2 volts

$$n := \frac{p}{v \cdot i} \quad n = 83.333$$

To supply power for the required 2 hours, x number of cells must be in series

Where:

x = maximum required current*time/cell current output

current := 30 amps
time := 2 hrs
cellcurrent := 6.5 amps

$$x := \frac{\text{current} \cdot \text{time}}{\text{cellcurrent}} \quad x = 9.231$$

Surface Area Calculations:

$$\begin{aligned}
 A_{\text{CONNECTIONS}} &= 0.01 \text{ m}^2 & A_{\text{ENDS}} &= \text{PI} \cdot (r(r^2+h^2)^{.5} + (r-.5)^2 \\
 A_{\text{WINDOWS}} &= 0.60 \text{ m}^2 & &+ 2 \cdot (r+r-.5)/2 \cdot (2(r-1)^2)^{.5}) \\
 A_{\text{CYL}} &= 2 \cdot \text{PI} \cdot r \cdot l = 65.9734 \text{ m}^2 & &= 17,190554 \text{ m}^2 \\
 \text{Total: } A_S &= 83.2 \text{ m}^2
 \end{aligned}$$

PLR Surface Temperature:

a = albedo L = luminosity s = sun m = moon P = PLR
 E = energy d = separation distance T = temperature

Assume: 50% PLR bottom surface covered with lunar dust/soil
 $1-a_{\text{ptop}} = 0.020$ $L_s = 3.83\text{E}+33 \text{ erg/sec}$
 $1-a_{\text{pbot}} = 0.4735$ $L_m(400\text{K}) = 5.51\text{E}+23 \text{ erg/sec}$
 $d_{\text{m-p}} = 173800150 \text{ cm}$ $d_{\text{s-p}} = 1.4665\text{E}+13 \text{ cm}$ $1-a_m = 0.927$

$$\begin{aligned}
 dE/dt|_{\text{rec}} &= dE/dt|_{\text{s-p}} + dE/dt|_{\text{m-p}} + dE/dt|_{\text{s-m-p}} \\
 dE/dt|_{\text{s-p}} &= (L_s/4 \cdot \text{PI} \cdot d^2) \cdot (A_S/2) \cdot (1-a_{\text{ptop}}) = 1.18\text{E}+10 \text{ erg/sec} \\
 dE/dt|_{\text{m-p}} &= (L_m/4 \cdot \text{PI} \cdot d^2) \cdot (A_S/2) \cdot (1-a_{\text{pbot}}) = 2.96\text{E}+11 \text{ erg/sec} \\
 dE/dt|_{\text{s-m-p}} &= dE/dt|_{\text{s-p}} \cdot (1-a_m) \cdot (1-a_{\text{pbot}})/(1-a_{\text{ptop}}) \\
 &= 2.59\text{E}+11 \text{ erg/sec}
 \end{aligned}$$

$$\begin{aligned}
 dE/dt|_{\text{rec}} &= 5.668\text{E}+11 \text{ erg/sec} \\
 dE/dt|_{\text{rad}} &= A_S \cdot o \cdot T_{\text{EFF}}^4 \quad \text{Energy received} = \text{Energy radiated} \\
 \text{Thus, } T_{\text{EFF}} &= [dE/dt|_{\text{rec}} / (A_S \cdot o)]^{1/4} = 331.08 \text{ K}
 \end{aligned}$$

Computing Heat Flux in/out of PLR:

Q = heat R = thermal resistance k = thermal conductivity

$$\begin{aligned}
 Q_{\text{shell}} &= (T_{\text{out}} - T_{\text{in}}) / R_{\text{tot}} \\
 R_{\text{tot}} &= \text{SUM: } \ln(r_o/r_i) / (2 \cdot \text{PI} \cdot k \cdot L) = R_{\text{safe haven}} + R_{\text{rest PLR}} \\
 R_{\text{sh}} &: 3 \text{ Carbon}(x: 8 \text{ mils, } k: 1.6 \text{ W/mK}), 2 \text{ Foam}(.5", .0231), \\
 &30 \text{ MLI}(1.3 \text{ mils, } 0.00029), \text{ and } 1 \text{ H}_2\text{O}(2.5 \text{ cm, } .597) \\
 R_{\text{rp}} &: R_{\text{sh}} - \text{H}_2\text{O layer. Length} = 5.8 \text{ m instead of } 1.2 \text{ m} \\
 R_{\text{tot}} &= 0.4022398 \text{ K/W} + 0.082729 \text{ K/W} = 0.4849688 \text{ K/W} \\
 Q_{\text{shell}} &= (T_{\text{out}} - T_{\text{in}}) \cdot 2.0619882 \text{ W/K} \\
 \\
 Q_{\text{windows}} &= (T_{\text{out}} - T_{\text{in}}) / R_{\text{tot}} \\
 R_{\text{tot}} &: \text{SUM: } x/kA = (1/A) \cdot \text{SUM: } (x/k) \\
 &3 \text{ glass}(k: 0.896 \text{ W/mK}), 2 \text{ air}(0.02512), \text{ each } x=3/40" \\
 R_{\text{tot}} &= 0.2632172 \text{ K/W} \\
 Q_{\text{windows}} &= (T_{\text{out}} - T_{\text{in}}) \cdot 3.7991444 \\
 \\
 Q_{\text{ends}} &= (T_{\text{out}} - T_{\text{in}}) / R_{\text{tot}} \\
 R_{\text{tot}} &= \text{SUM: } x/kA = 4.51238 \text{ K/W} \quad \text{See } R_{\text{rp}} \text{ data, } A = 17.19 \text{ m}^2 \\
 Q_{\text{ends}} &= (T_{\text{out}} - T_{\text{in}}) \cdot 0.2216125 \text{ W/K} \\
 \\
 Q_{\text{conn}} &= (T_{\text{out}} - T_{\text{in}}) \cdot kA/x \quad (A=0.01 \text{ m}^2, x=3/8", k=1.6 \text{ W/mK}) \\
 Q_{\text{conn}} &= (T_{\text{out}} - T_{\text{in}}) \cdot 1.6810667 \text{ W/K} \\
 \\
 Q_{\text{PLR}} &= \text{SUM } (Q_i) = (T_{\text{out}} - T_{\text{in}}) \cdot 7.763812 \text{ W/K}
 \end{aligned}$$

References: 41, 42, 43, 44, 45

PLR Radiator Heat Load:

Assume all power consumed is dissipated as heat.
 LSS power consumption = 1375 W Thus, let $Q_{LSS} = 1375$ W
 Electronic consumption = 544 W Thus, let $Q_{ELECT} = 544$ W

Additional heat sources: crew metabolism and PLR heat flux
 $Q_{CREW} = 342$ W $Q_{PLR} = 7.7638 * (T_{OUT} - T_{IN})$
 $T_{IN} = 295$ K maximum $T_{OUT} = 331$ K minimum $T_{OUT} = 80$ K

Sum up all heat sources to find total heat load.
 Thus, $Q_{MAX} = 2540.4972$ W $Q_{MIN} = 591.78048$ W

PLR Radiator Area Calculations:

Equations: $q = e * \sigma * (T_{rad}^4 - T_s^4)$ $A = Q / q$

Variables:

q - heat flux (W/m^2) Q - PLR heat load
 T_s - effective sink temp (K) A - radiator area
 T_{rad} - rad temperature (K) e - rad emissivity
 σ - Stefan-Boltzmann constant ($W/m^2 * K^4$)

Calculations (Area FS = 1.5):

$T_{space} = 4$ K Assume moon view factor = 0.15
 $T_s = 0.85 * (4 \text{ K}) + 0.15 * (400 \text{ K}) = 63.4$ K
 $q(T_{rad}=300 \text{ K}) = 0.8 * 5.67 * 10^{-8} * (300^4 - 63.4^4) = 366.7$ W/m^2
 $A = FS * 2540.50 \text{ W} / 366.70 \text{ W/m}^2 = 10.39$ m^2

$q(T_{rad}=400 \text{ K}) = 0.8 * 5.67 * 10^{-8} * (400^4 - 63.4^4) = 1160.5$ W/m^2
 $A = FS * 2540.50 \text{ W} / 1160.5 \text{ W/m}^2 = 3.283$ m^2

Heat Pump's Mass Savings:

Mass Decrease = $10 \text{ kg/m}^2 * (10.39 - 3.283) = 71.07$ kg
 Mass Increase = $11 \text{ kg/kW-cooled} * 2.540 \text{ kW} = 27.94$ kg

Net Mass Reduction:

Decrease - Increase = $71.07 - 27.94 = 43.13$ kg

N-Eicosane Calculations:

Characteristics:

$T_{melt} = 309.7$ K $C_{psol} = 2210$ J/kg K
 $T_{max} = 368.0$ K (arbitrary) $C_{pliq} = 2010$ J/kg K
 $T_{min} = 292.0$ K density = 856 kg/m^3
 $h_f = 247000$ J/kg

Heat Stored:

$Q(J) = m * [C_{psol} * (T_{melt} - T_{min}) + C_{pliq} * (T_{max} - T_{melt}) + h_f]$
 $= m * 403.3$ kJ/kg

Install 2 canisters: $m = 72.03$ kg vol = 0.08415 m^3

References: 46, 26, 27, Table 4-1

APPENDIX 4-2: Storage Tank Dimensions

2 Oxygen (O₂) Tanks:

$M_{O_2} = 176.27 \text{ kg}$
 $P_{\text{tank}} = 2215 \text{ psi} = 15284000 \text{ N/m}^2$
 $T = 294 \text{ K}$
 $R_{O_2} = 259.8 \text{ J/kg-K}$
 Using perfect gas law,

Result: $r = 0.24 \text{ m}$, $l = 2.44 \text{ m}$

1 Nitrogen (N₂) Tank:

$M_{N_2} =$
 $P_{\text{tank}} = 2215 \text{ psi} = 15284000 \text{ N/m}^2$
 $T = 294 \text{ K}$
 $R_{N_2} = 296.8 \text{ J/kg-K}$
 Using perfect gas law,

Result: $r = 0.214 \text{ m}$, $l = 1.87 \text{ m}$

Water Tanks:

Potable Water Tank:

$M_{H_2O} = 297.534 \text{ kg}$ ----- $\text{Vol} = 0.297534 \text{ m}^3$

Result: $r = 0.24 \text{ m}$, $l = 1.65 \text{ m}$

Water Recovery Tanks:

Load: initial (91.256kg) + humidity (1.82 kg/m-d)
 + EVA (0.91 kg/m-E) = (FS = 1.2) = 220.112 kg
 Total Volume = 0.220112 m³

Results:

Holding Tank : $r = 0.1875 \text{ m}$, $l = 2.00 \text{ m}$
 Storage Tank : $r = 0.225 \text{ m}$, $l = 1.39 \text{ m}$
 Hot/Cold Tanks: $r = 0.150 \text{ m}$, $l = 1.56 \text{ m}$

Urinal Storage Tank:

Load: Flush (0.50 kg/m-d) + Urine (1.50 kg/m-d)
 = 190.4 kg -----> $\text{Vol} = 0.1904 \text{ m}^3$

Result: $r = 0.177 \text{ m}$, $l = 1.95 \text{ m}$

All values computed using figures from Table 4-1, 4 men, 14 days, and a factor of safety of 1.7, unless stated otherwise.

APPENDIX 4-3: Water Management Calculations

Bed Flow:	
Vel in bed	= 3.9 cm/sec -- equivalent to 79 cc/min
Vol of bed	= $2.0546 \times 10^{-3} \text{ m}^3$
Contact time	= $2.0546 \times 10^{-3} \text{ m}^3 / 79 \text{ cc/min} = 26 \text{ min}$
Media Usage Rate -- 3.1 cc media / l processed H ₂ O	
Replace a canister every 663 liters processed H ₂ O	
H ₂ O Processed Daily:	4m(1.81 + 5.5 + 5.67 + 1.81 + 0.44)kg + 6E(0.91)kg = 66.38 l (max in one day)
No EVA:	60.92 l
# of Days between canister replacement: 663/66.38 = 10 days	
# of Days bt. canister replacement (no EVA) = 10.9 days	
Daily Operation Time: 66.38 l / 79 cc/min = 14 hrs	
Daily Operation Time (no EVA): 12 hrs, 51 min	

APPENDIX 4-4: Extra Supplies (See Fig. 4-6)

S	QTY	ITEM	SYMBOL	MASS (kg)
F	1	WMM Filter	F	0.10
F	2	Pumps	P	3.00
F	2	Fans	FAN	2.70
F	2	Multimedia bed	MMB	4.00
F	1	Iodine Remover Bed	IR	1.00
F	1	Generator	G	4.00
F	1	LiOH canister	LiOH	20.00
F	2	Charcoal canister	CC	6.00
F	1	Treated charcoal canister	TCC	3.00
F	1	Iodine Supplies	IS	0.25
W	1	Camera/Lights	CL	5.00
W	1	Tool Kit	TK	15.00
W	1	Fire Alarm	FA	0.25
W	1	Fire extinguisher	FE	3.00
W	1	AA batteries for FA	BAT	0.10
W	1	Set of System Manuals	MAN	0.10
W	1	Human waste bags	WB	0.25
W	1	Generic urinal cup	CUP	0.25
W	1	Tissue paper	TP	0.50
W	1	Soap/Shampoo/etc	SS	0.50

S	- Storage Area
F	- Under Floor Storage
W	- Behind walls/Storage for easy crew access
QTY	- Quantity

APPENDIX 5-1

Calculation of antenna size

For parabolic reflector:

$$G=17.8+20*\log(D)+20*\log(f)$$

(efficiency=0.55)

G=maximum gain

D=diameter of dish

f=frequency of signal

For X-band:

f=8.20 GHz (average power for band)

G=35.0 dB

$$35.0=17.8+20*\log(D)+20*\log(8.20)$$

Solving for D yields:

$$D=0.9055 \text{ m}$$