

59-63
150409

N93-22215 14

A New Approach for Designing Self-Organizing Systems and Application to Adaptive Control

P.A. Ramamoorthy, Shi Zhang, Yueqing Lin and Song Huang
Department of Electrical and Computer Engineering
University of Cincinnati, M. L. 30
Cincinnati, Ohio 45221-0030
FAX:(513) 556-7326; TEL: (513) 556-4757
Email: pramamoo@nest.ece.uc.edu

Abstract

There is tremendous interest in the design of intelligent machines capable of autonomous learning and skillful performance under complex environments. A major task in designing such systems is to make the system plastic, and adaptive when presented with new and useful information and stable in response to irrelevant events. A great body of knowledge, based on neuro-physiological concepts, has evolved as a possible solution to this problem. Adaptive resonance theory (ART) is a classical example under this category. The system dynamics of an ART network is described by a set of differential equations with nonlinear functions.

An entirely new approach for designing self-organizing networks characterized by nonlinear differential equations is proposed in this paper. Similar to the neuro-physiological approach, the method presented here relies upon another area - that of passive nonlinear network theory. A passive nonlinear network is formed by proper interconnection of various nonlinear elements where each and every nonlinear element is constrained to be lossless or lossy. When energy storing elements are present in such a network, we can obtain a set of Input/Output relationships as nonlinear differential equations. The basic property that the network is lossy (consumes energy) ensures that the nonlinear differential equations obtained from the network would represent absolutely stable systems and this property holds as long as the individual element values are maintained in their permissible range of values. Thus, to design complex nonlinear systems (a complex nonlinear plant plus a controller to optimize its performance, for example) and self-organizing systems, one simply has to force the system dynamics to mimic the dynamics of a properly constructed passive nonlinear network, a process akin to reverse engineering.

In our research which is in its early stages, we have developed the basis for the above approach and applied it with relative ease to a number of problems leading to encouraging results. The fruits of such an approach seem to be endless. For example, the approach can be applied to linear and nonlinear controller design (for linear and nonlinear plants), self tuning controllers, model reference adaptive controllers, self-organizing networks, adaptive IIR filter design, adaptive beam-forming, two-dimensional systems, fuzzy systems etc. In this paper, we provide some details of this approach and show results from some of these topics to show the power of this approach.

1 Introduction

There is currently tremendous interest and research activity in the areas of neural networks and fuzzy logic. The major driving force behind all these efforts is the hope that they can provide creative and novel solutions to the design of complex, autonomous and self-organizing systems. Fuzzy logic tries to mimic human approach to decision making when presented with fuzzy and often conflicting data and rules. Neural networks have originated from efforts to mimic neuro-physiological behavior.

From a functional point of view, both neural networks and fuzzy expert systems implement a mapping $f: u \rightarrow y$, where u is an input vector, y the output vector and f is the mapping function which in general is a highly nonlinear function. In the case of fuzzy expert systems, the mapping is achieved through higher order logical relations between the inputs and the outputs where as in the case of neural networks, it is achieved through simple but repetitive linear and nonlinear operations. Fuzzy expert systems by themselves are feed-forward systems but their use in applications such as control lead to systems with feedback. Neural net architectures can either be feed-forward architectures or architectures with feedback. The system dynamics of feedback (also known as recurrent) neural networks are in general represented by a set of differential equations with nonlinear terms. Self-organizing techniques through which fuzzy rules and membership functions are learnt or improved are conceptually similar to the learning or training procedures in the neural network domain.

When we deal with systems with feedback, **the object of this paper**, stability becomes an important issue and has to take precedence over learning or self-organizing. However, it is not easy to establish stability of large-scale nonlinear systems. In fact, it is known that a first-order nonlinear equation with just one parameter can lead to stable, unstable and chaotic situations depending upon the value of that parameter. In this paper, we establish a frame work for designing such **feedback or recurrent systems that are guaranteed to be stable** with relative ease and show how it can be incorporated into fuzzy expert systems and neural networks with self-organizing capability.

2 The Basic Philosophy

As indicated before, our desire to mimic human cognition and functioning of neuro-physiological architectures has led to the two areas: Fuzzy logic and neural networks. The basic philosophy behind our new approach is to use "Passive Nonlinear Network Theory" to build new neural architectures with internal feedback. As will be shown, it leads to a new paradigm that is easier to handle (at least for engineers and computer scientists) than neuro physiology or human cognition.

A passive nonlinear network is simply an electrical network formed by proper interconnection of various nonlinear elements. The nonlinear elements in the network are constrained to be either lossless or lossy and the interconnections are such that the basic circuit laws are obeyed. As an example, the equation

$$i_R(t) = G \tan^{-1}(v_R(t)) \quad (1)$$

represents a two-terminal passive nonlinear resistor since

$$p(t) = i_R(t)v_R(t) \geq 0 \quad \text{for all } t$$

indicating that the element consumes power all the time. In addition to the already known passive nonlinear resistors, we have defined a number of passive nonlinear elements. When such elements are interconnected with dynamic elements as shown in Fig.1, we can write down the dynamic equations for the network as a set of stable nonlinear equations:

$$[PI]\dot{X} = F[X, U] \quad (2)$$

where

$$X = [i_{L_1}, i_{L_2}, \dots, i_{L_L}, v_{C_1}, v_{C_2}, \dots, v_{C_C}]^T$$

$$P = [L_1, L_2, \dots, L_L, C_1, C_2, \dots, C_C]$$

$$U = [I_1, I_2, \dots, I_I, V_1, V_2, \dots, V_V]$$

I, an identity matrix of size $(L_L + C_C) * (L_L + C_C)$

F, a vector of nonlinear functions of X and U

and

'.' indicates differentiation.

It can be observed that the set of equations given in (2) represents a stable network or system as long as the element values are in the permissible range so as to retain the lossy or lossless property. The stability property holds good even if we incorporate complex, exotic nonlinear elements. If such a system is turned on with only initial stored energy in the dynamic elements, the state variables will all go to zero as time progresses.

Reader familiar with the ART networks [1-4] will recognize immediately the similarity in the structure of the set of equations (2) obtained from the passive network and the set of equations characterizing ART networks:

$$\epsilon \dot{x}_k = -x_k + (1 - Ax_k)J_k^+ - (B + Cx_k)J_k^- \quad k = 1 \text{ to } M + N \quad (3)$$

$$\dot{Z}_{ij} = k_1 f(x_j)[-E_{ij}Z_{ij} + h(x_i)] \quad i = 1 \text{ to } M; \quad (4)$$

$$\dot{Z}_{ji} = k_2 f(x_j)[-E_{ji}Z_{ji} + h(x_i)] \quad j = i \text{ to } M + 1 \quad (5)$$

where the descriptions of the various terms can be found in the references. However, a major difference between ART dynamic equations and the set of equations derived from

the passive networks is that the former has been derived from an understanding of difficult cognition processes and slow evolution (ART-1 to ART-2 and so on). The passive network approach enables us to come up with a number of entirely different sets of equations with relative ease as will be obvious from the examples given. Another difference is that the ART equations are written in such a way that some state variables are forced to reach saturation (similar to introducing activity or nonlossy property in some of the elements in the network). The "Winner-Take-All" portion of the ART network belongs to this category.

The basic philosophy behind our design approach is to 1) define a number of nonlinear elements obeying the lossless or lossy condition, 2) form a generic network architecture that would lead to most general form of nonlinear state equations and 3) force the state equations corresponding to the system under consideration to obey the form given in equation (2). The property that the equations represent a stable network whether they are set to a fixed mode or in a self-organizing mode makes this approach unique and promising.

3 Simulation Examples

In this section, we provide a number of examples to illustrate the applicability of the approach to a number of problem domains.

3.1 Nonlinear/Adaptive Controller Design

Consider a single-degree-of-freedom manipulator represented by a 2nd - order transfer function as shown in Fig.2. The task is to design an adaptive controller which will force the manipulator to follow a desired trajectory.

The classical approach in adaptive control is to define a control input

$$T(t) = -k_1q - k_2\dot{q} \quad (6)$$

and adapt the coefficients $K=[k_1, k_2]^T$ using

$$[\dot{k}] = -c \frac{\partial e^2}{\partial k} \quad (7)$$

where e corresponds to the tracking error.

A network based controller using the same form for control input as in (6) is given by

$$\begin{aligned} \dot{k}_1 &= -(k_1 + \frac{4}{\pi} \tan^{-1}(k_1)) + q\dot{q} + k_2 + 1 \\ \dot{k}_2 &= -(k_2 + \frac{4}{\pi} \tan^{-1}(k_2)) - k_2 + 3 \end{aligned} \quad (8)$$

where the controller equations have been obtained so as to force the plant and the controller combination mimic a fourth-order passive nonlinear dynamic network ¹ and assuming that the desired output of the plant as $q_d, \dot{q}_d = 0$. The constants in the equations are chosen to let k_1, k_2 to 1 as $t \rightarrow \infty$.

Another set of controller equations based on the network approach is given by

$$\dot{k}_1 = -(k_1 + \frac{4}{\pi} \tan^{-1}(k_1)) + q\dot{q} + k_2 + 1 \quad (9)$$

$$\dot{k}_2 = -(k_2 + \frac{4}{\pi} \tan^{-1}(k_2)) + \dot{q}^2 - k_2 + 3$$

We provide this addition controller expression simply to illustrate how easy it is to derive alternate forms.

We have shown some simulation results in Figs. 3A-C using the controller expressions in (8). The simulations were carried out assuming different initial values for q, \dot{q} and some initial values for k_1 and k_2 and the task of the controller is to move the manipulator to location zero. Figs. 3A and 3B shows q, \dot{q} as a function of time and Fig 3C shows a phase plane plot (q Vs \dot{q}) of the manipulator. It can be noted that the adaptive controller does a good job of controlling the manipulator. Though we are not including the results, we have performed the simulations with a) error in the plant coefficient values, b) a sudden change in the values of the friction and compliance coefficients and c) unmodeled dynamics represented by another second-order transfer function. The results were really impressive and showed the robustness of the nonlinear adaptive controller obtained using the network approach. It should be noted here that nonlinear functions such as $\tan^{-1}(k_1)$, initial and final values for k_1 and k_2 etc were chosen randomly with no efforts to optimize anything.

3.2 Application to Fuzzy Control

Fuzzy logic [5] has been used to design controllers for various systems and processes [ref. 6, for example]. The classical approach is to find the difference between the actual and desired outputs and the derivatives of the outputs and use a fuzzy expert system to generate the control input(s) (see Fig. 4A). Thus, the plant and the controller form a closed loop and the stability of the feedback system could become an issue. The architecture could be easily modified to mimic a passive network (as shown in Fig. 4B) and hence guarantee stability.

To illustrate this concept, we have taken a third order model example used in ref.[7], retained only the two dominant poles and used the fuzzy look-up table given in that paper with some modifications to generate the fuzzy controller output $F(e, \dot{e})$. Denoting the transfer function of the plant as

¹We are not going into complete details of deriving the equations as we are in the process of patenting some of the nonlinear elements and their applications.

$$H(s) = \frac{b}{s^2 + as + b} = \frac{Y(s)}{U(s)} \quad (10)$$

with u as input to the plant, and y the output of the plant, the dynamics of the complete system is given by

$$\begin{aligned} \dot{y} &= y_1 \\ \dot{y}_1 &= -by - ay_1 + u \\ u &= kF(e, \dot{e}) \\ \dot{k} &= -y_1F(e, \dot{e}) - k - \frac{4}{\pi} \tan^{-1}(k) + u_1 \end{aligned} \quad (11)$$

where u_1 is chosen to force k to a particular value as the plant output moves to the target value. The responses of the plant using the classical fuzzy control approach and the new network based approach for two values of $k(\infty)$ are shown in Fig 5. It can be noted that there is some improvement in the response². However, the key point here is that the system represented by equation (11) will remain stable and robust for external disturbances.

3.3 Application to Model Reference Adaptive Control (A Simple Self-Organizing System)

Here we consider the application of the passive network approach to model reference adaptive control (MRAC) where the aim is to design a controller such that the combined system (plant + controller) mimics a given model. The problem is quite simple if the plant model and the parameters are known precisely. If that is not the case or if the parameters vary with respect to time, an adaptive controller is the preferred solution. The set-up for the classical adaptive control as well as the new network based approach are shown in Fig. 6. The classical approach is to use a gradient based technique to update the controller parameters but is known to be prone to instability etc.

The set of equations comprising the whole adaptive system based on the network approach is given by footnote We used subscripts m , p , t to denote closed-loop-model, plant and time-evolving model respectively.

$$\begin{aligned} \theta_m &= \theta_t(t) + k && \text{(closed-loop-model requirement)} \\ \dot{x}_p &= -\theta_p x_p - k x_p + r && \text{(plant dynamics)} \\ \dot{x}_t &= -\theta_t x_t - k x_p + r = k(x_t - x_p) - \theta_m x_t + r \\ &&& \text{(dynamics of the time-evolving model of the plant)} \end{aligned} \quad (12)$$

$$\dot{k} = x_p x_p + (x_p - x_t) x_t - F_1(x_p - x_t) \left(k + \frac{4}{\pi} \tan^{-1}(k) \right) - x_m^2$$

²It appears that the original fuzzy controller has already been optimized very well.

(controller dynamics)

where

$$F_1(x_p - x_t) = \begin{cases} 1 & \text{when } |x_p - x_t| \geq 1 \\ |x_p - x_t| & \text{otherwise} \end{cases}$$

Again, the expression for the controller dynamics was obtained by forcing the three different dynamics to mimic a highly coupled passive network. The set of equations were simulated using some initial values for x_p, x_m, x_t, k and $r(t)$, a sinusoidal function. The time evolution of $k(t)$ is shown in Fig.7. It can be noted that k tends to its expected value of 0.5 in nearly 1500 iterations, a nice feat for an almost randomly chosen controller function. The key point to be noted from this example is that self-organizing networks can also be designed very easily using the new approach.

It is noted above that the classical MRAC approach can lead to instability under certain conditions. This could probably be explained using network concepts by noting that there are two closed loops in the whole system, one involving the plant and the controller and the other involving the plant, adaptive control law and the controller. The two loops were formed by some mathematical considerations and do not seem to be coupled as well as a network based approach and the complete system is not constrained to be passive and lossy. Hence the possibility for instability.

4 Summary

An entire new and exciting approach for designing nonlinear systems and self-organizing networks is proposed in this paper. The approach is based on a simple yet powerful concept that of using properties of properly constructed nonlinear passive networks. We have shown examples from different areas indicating how the approach can be applied to many different areas and the possible applications seem to be endless. The preliminary results obtained so far are very encouraging. We believe that it is just the beginning of a new era for a powerful methodology which can compete with approaches mimicking human cognition.

5 Reference

1. S. Grossberg, "Adaptive pattern classification and universal recoding II; Feedback, expectation, olfaction and illusions," *Biol. Cyber.* 23, 187, 1976.
2. G. A. Carpenter and S. Grossberg, "A massively parallel architecture for a self-organizing neural pattern recognition machine," *Comp. Vision, Graphics, and Image Proc.*, vol. 37, pp. 54-115, 1987.
3. G. A. Carpenter and S. Grossberg, "ART2: self-organization of stable category recognition codes for analog input patterns," *Applied Optics*, vol. 26, pp. 4919-4930, 1987.

4. G. A. Carpenter and S. Grossberg, "ART3: hierarchical search using chemical transmitters in self-organizing pattern recognition architectures," *Neural Networks*, vol. 3, pp. 129-152, 1990.
5. L. Zadeh, "Outline of a new approach to the analysis of complex systems and decision processes," *IEEE Trans. Sys., Man, Cybern.*, vol. smc-3, pp. 28-44, 1973.
6. S. Chiu, S. Chand, D. Moore and A. Chaudhary, "Fuzzy logic for control of roll and moment for a flexible wing aircraft," *IEEE Control Systems Magazine*, pp. 42-48, June 1992.
7. S. Tzafestas and N. P. Papanikolopoulos, "Incremental Fuzzy Expert PID Control," *IEEE Trans. on Industrial Electronics*, pp. 365-371, vol. 37, No. 5, Oct. 1990.

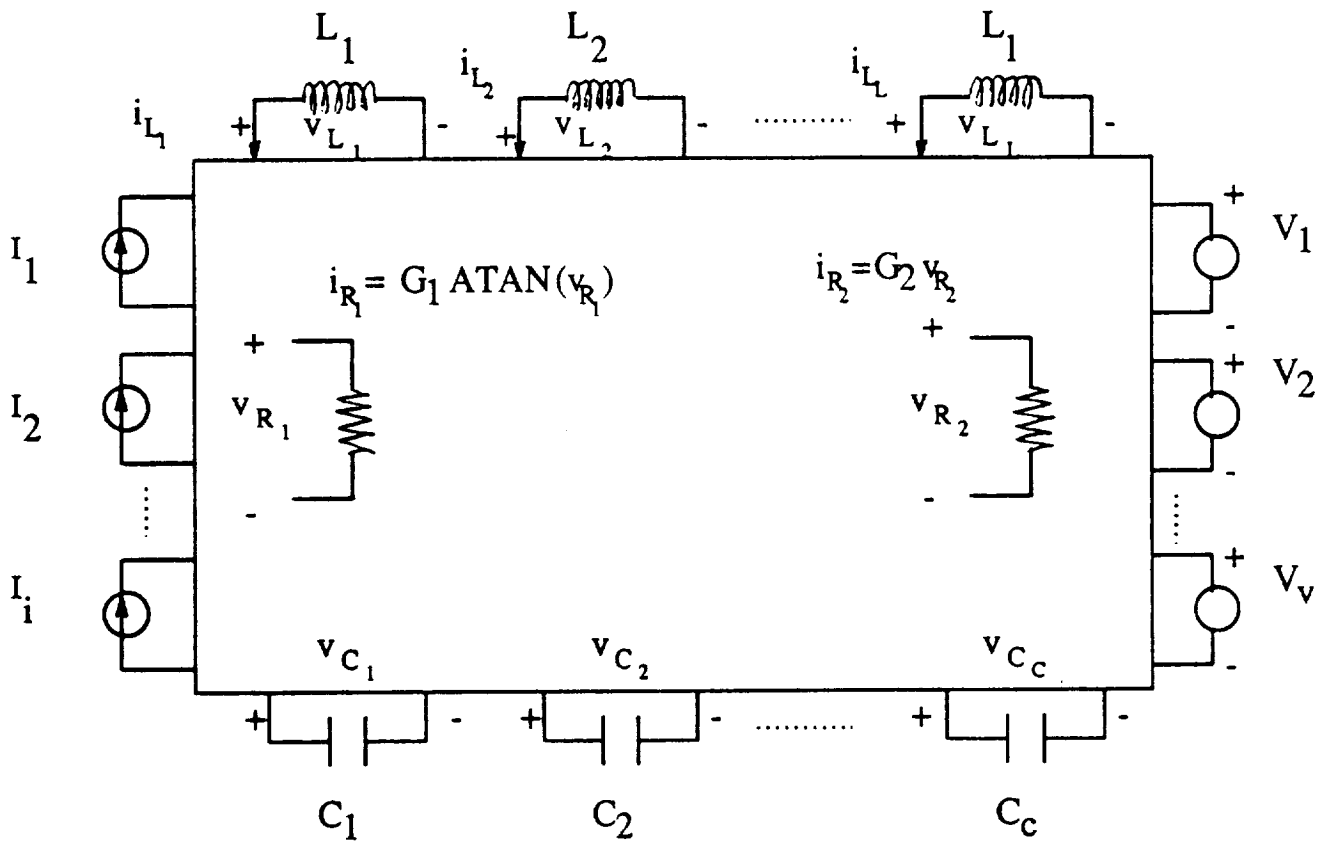
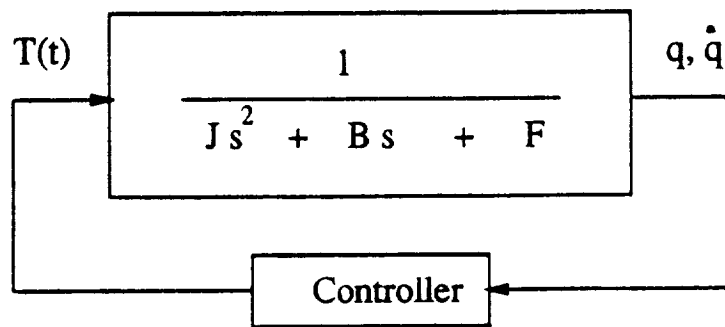

Fig. 1 A passive nonlinear dynamical network.



q : joint angle J : moment of inertia = 1
 \dot{q} : joint velocity B : viscous friction = 5
 $T(t)$: applied torque F : compliance coefficient = 0.7

Fig. 2 A manipulator with a single degree of freedom.

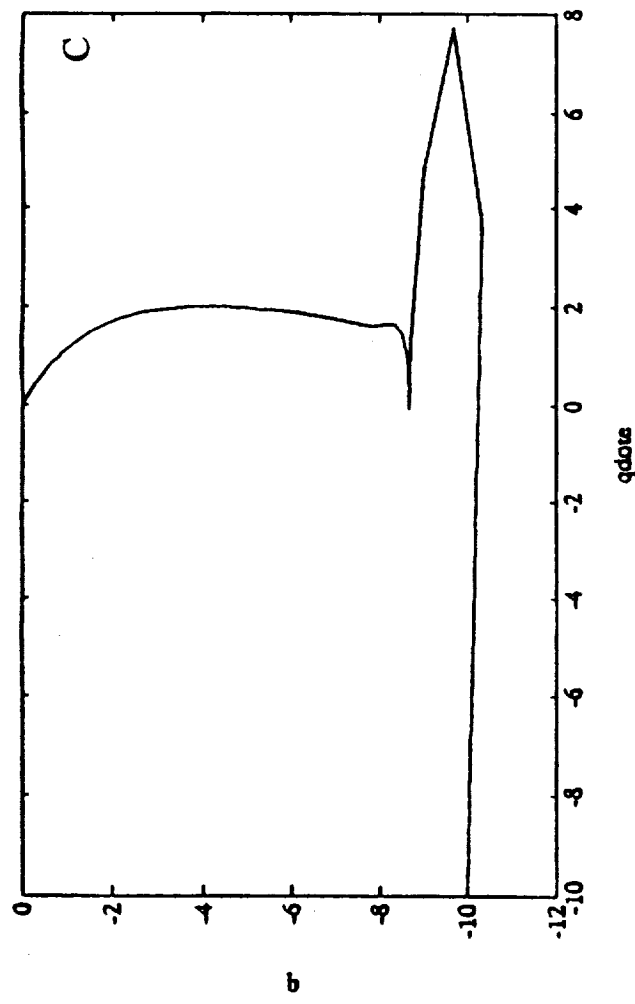
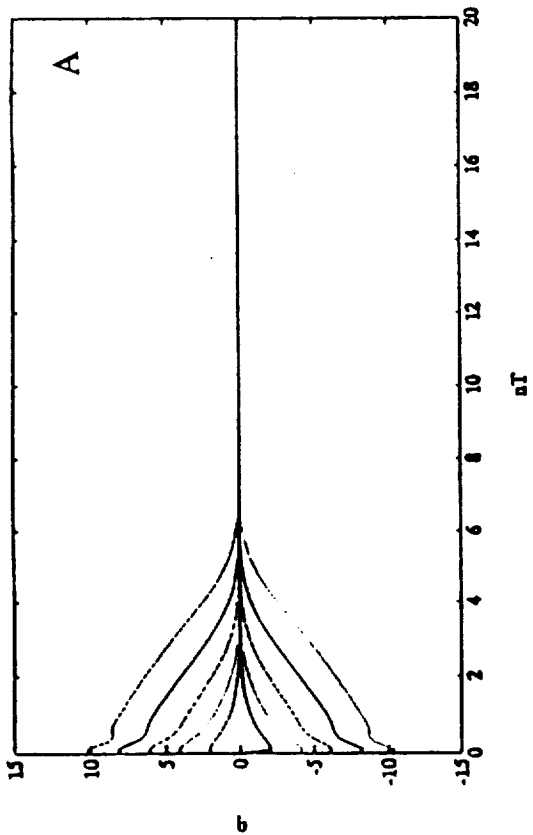
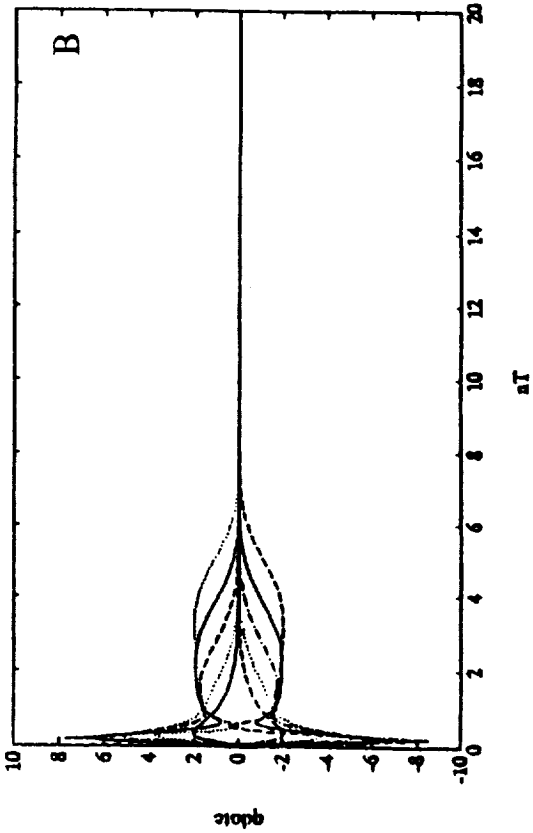
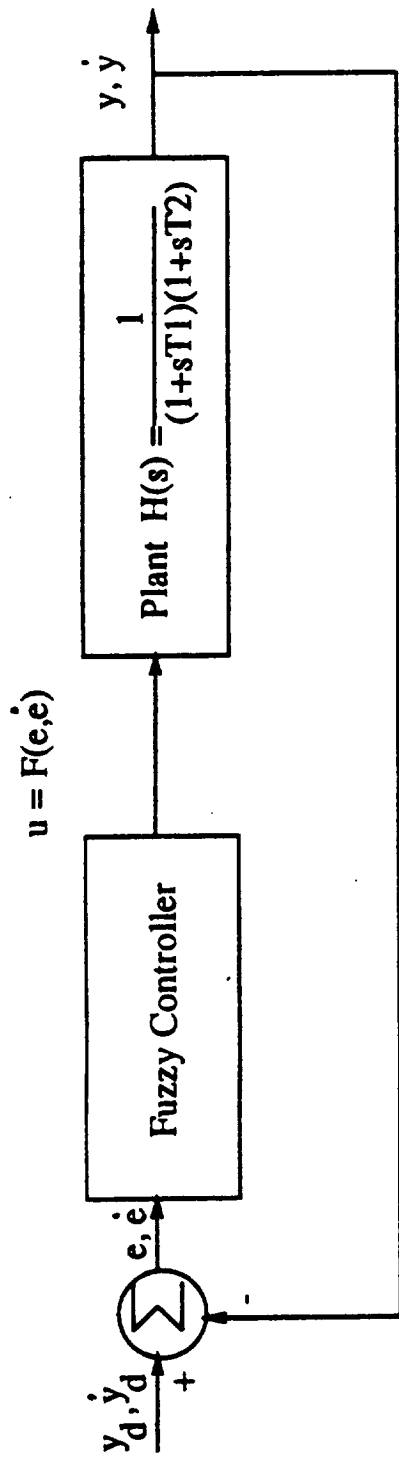
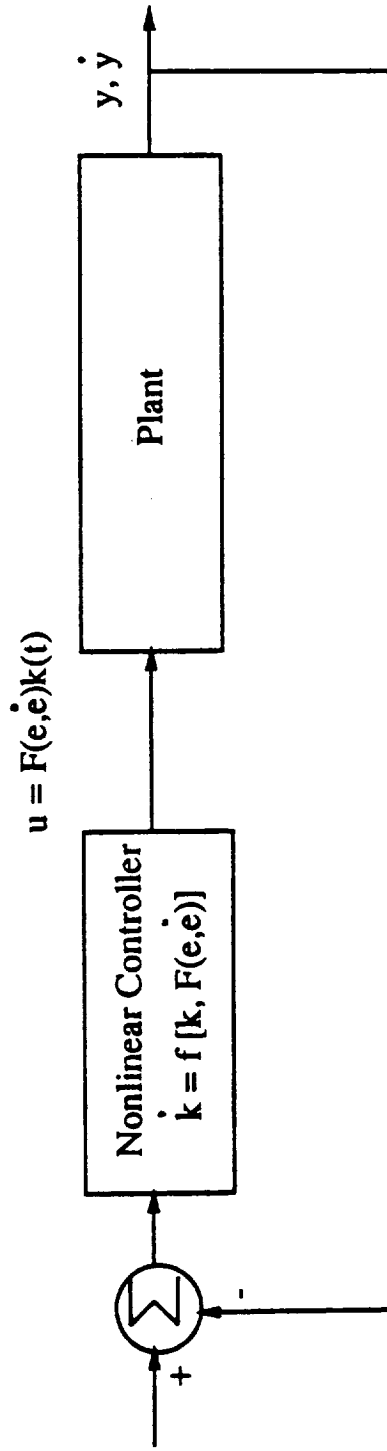

Fig. 3 A. The plant response as a function of time. B. The derivative of the plant as a function of time. C. phase-plane plot of the plant.



A. Classical Fuzzy Control Approach.



B. New Nonlinear Network Based Approach.

Fig. 4 Application to Fuzzy Control.

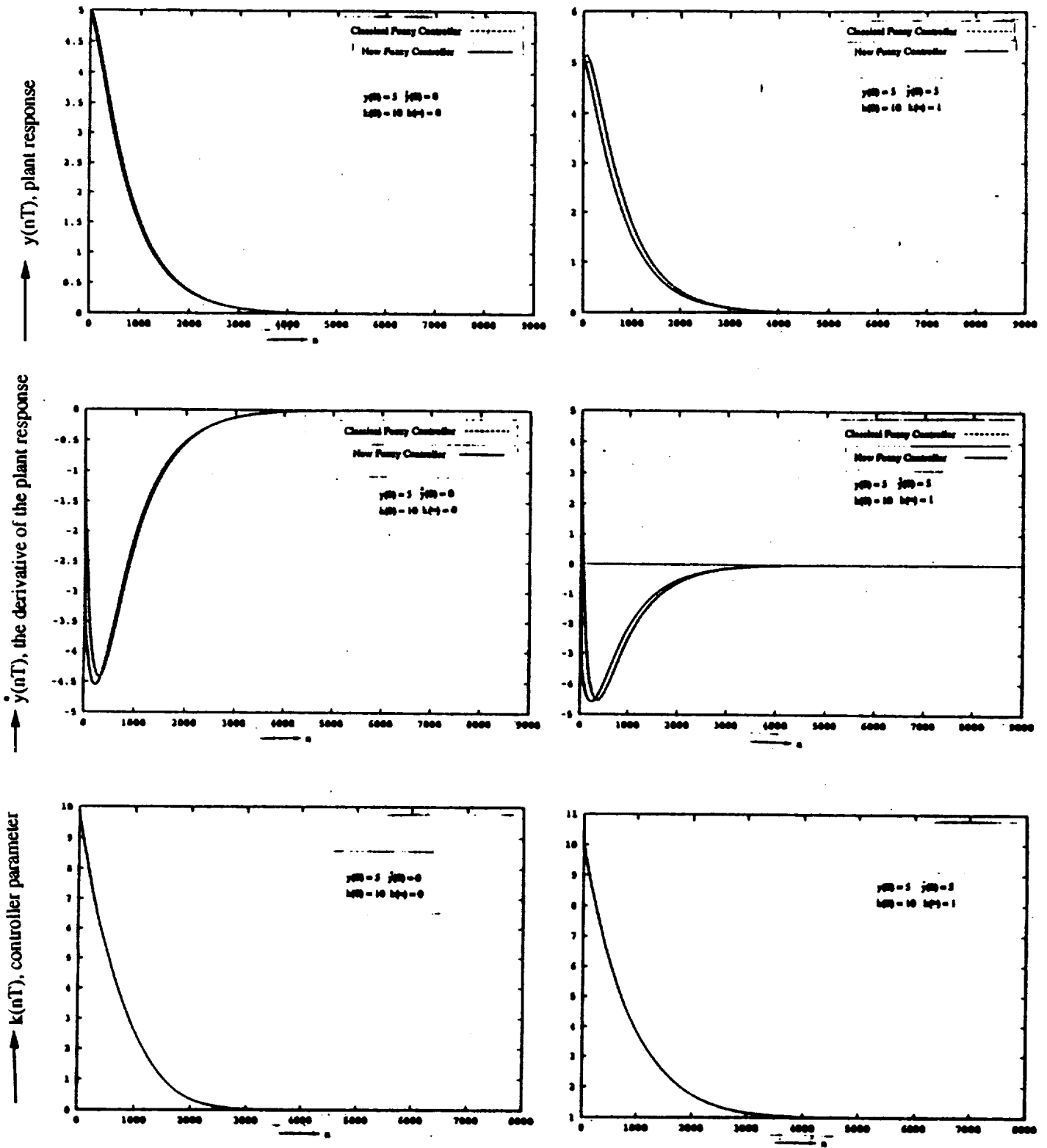

Fig. 5 Response of the plant using classical and network based fuzzy controller.

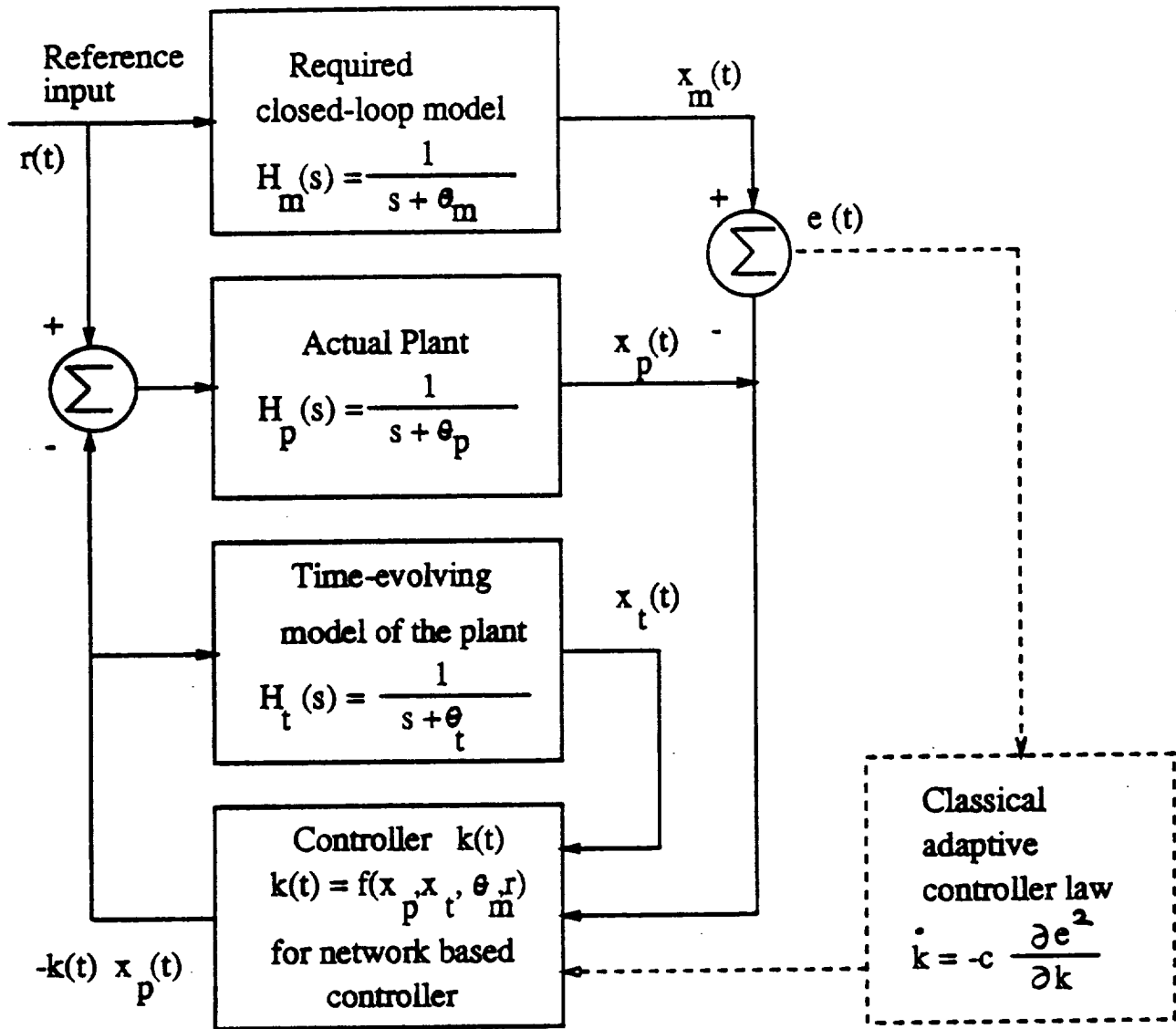

Fig. 6 Model reference adaptive control using classical adaptive control law and the new network based approach. $\theta_m = 1$, and $\theta_p = 0.5$ used in the simulation.

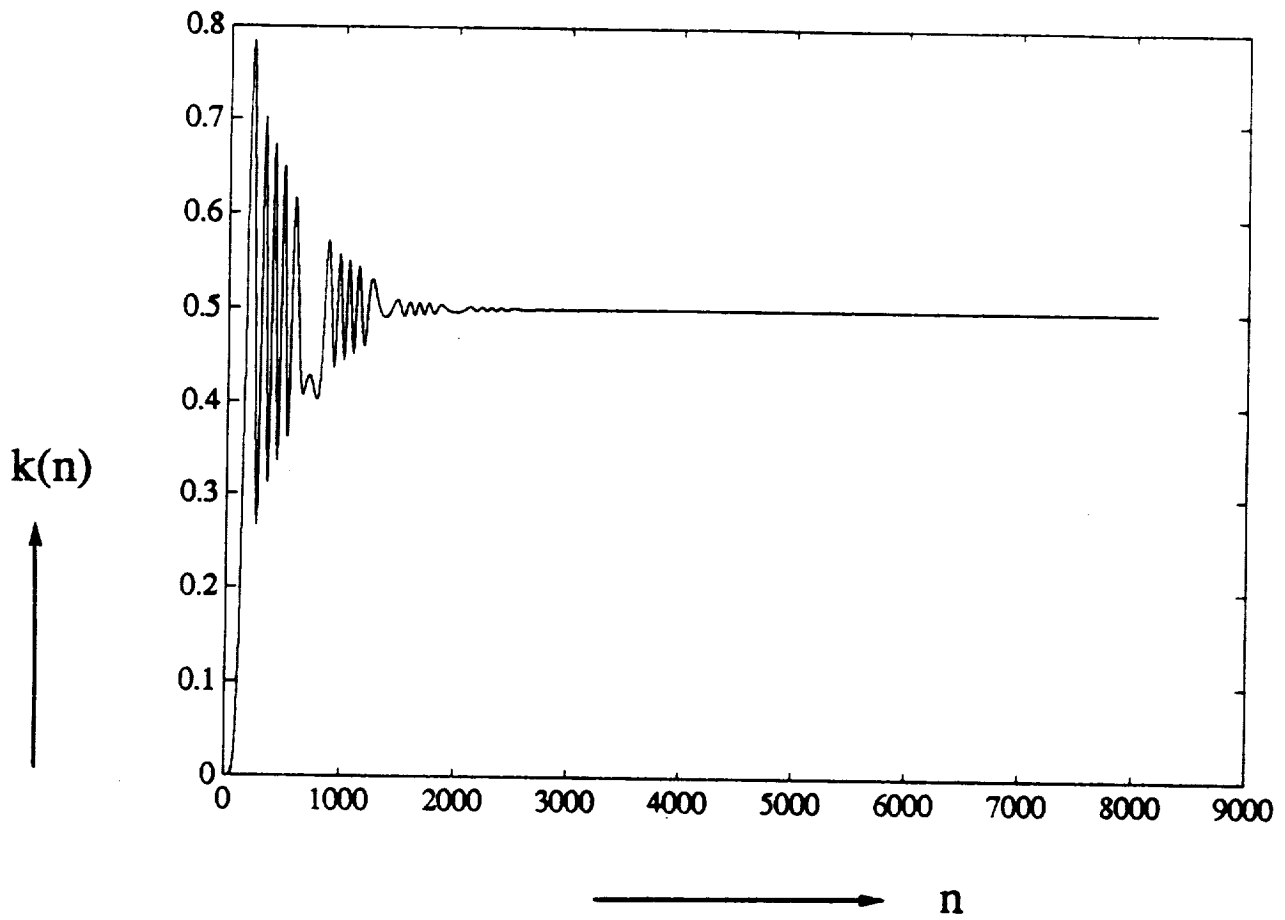

Fig. 7 Time evolution of the controller parameter k .