

FI lib
11/91
1-93
P. 224

A Compilation Of The Abstracts
Submitted For The
**NASA Automated Rendezvous
And Capture Review**

INFORMATION SCIENCES LIBRARY
AMES RESEARCH CENTER
MOFFETT FIELD, CALIF.

DEC 19 1991

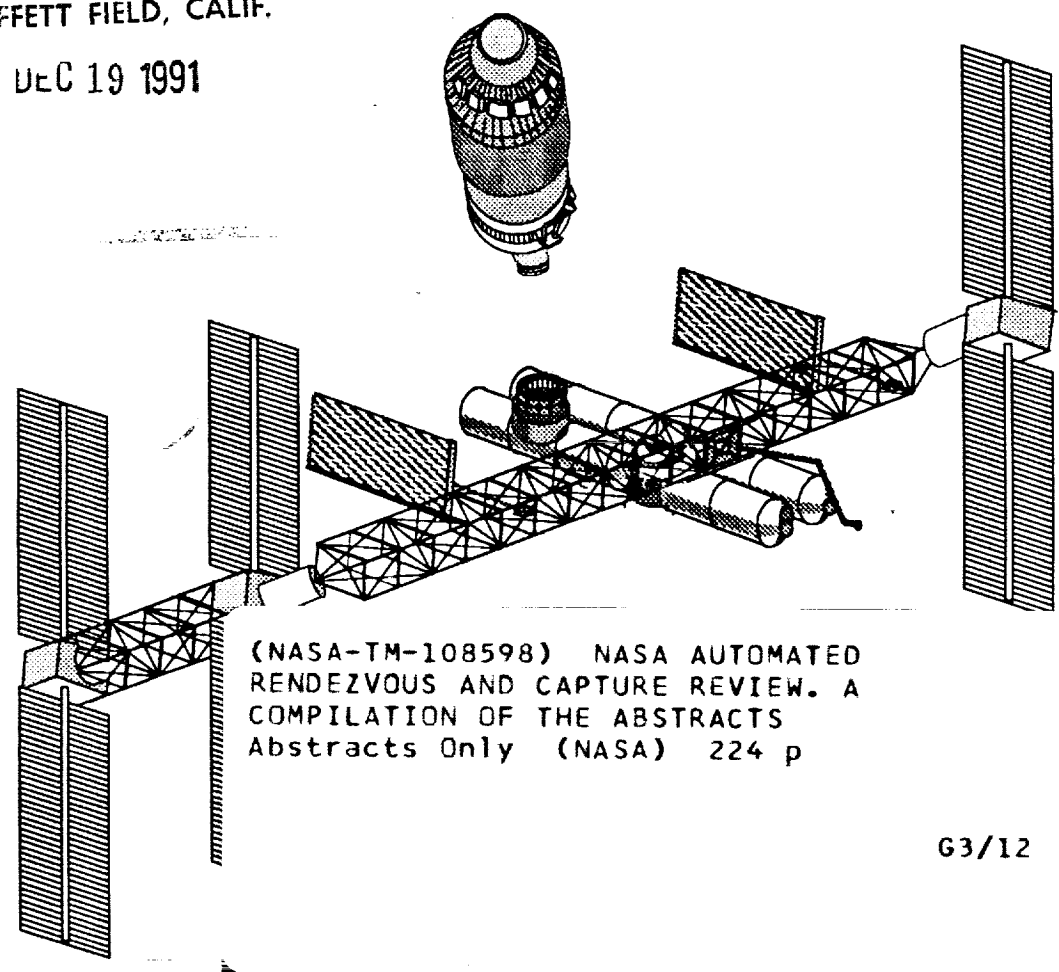

(NASA-TM-108598) NASA AUTOMATED
RENDEZVOUS AND CAPTURE REVIEW. A
COMPILATION OF THE ABSTRACTS
Abstracts Only (NASA) 224 p

N93-22226
--THRU--
N93-22321
Unclas

G3/12 0146711

Ft. Magruder Inn
Williamsburg, VA
19-21 November 1991

Acknowledgement

This document was prepared for distribution at the NASA Automated Rendezvous and Capture (AR&C) Review at the Ft. Magruder Inn in Williamsburg, VA on November 19-21, 1991. The document is a compilation of all abstracts submitted to the organizing committee for the NASA AR&C Review. The compilation was accomplished by personnel at SRS Technologies in Arlington, VA under contract NASW - 4341 at the direction of Ms. Barbara Askins, Advanced Program Development Division, NASA Headquarters, Washington, DC.

PRIMARY

PREFACE

This document presents a compilation of abstracts of papers solicited for presentation at the NASA Automated Rendezvous and Capture Review held in Williamsburg, VA on November 19-21, 1991. Due to limitations on time and other considerations, not all abstracts could be presented during the review. The organizing committee determined however, that all abstracts merited availability to all participants and represented data and information reflecting state-of-the-art of this technology which should be captured in one document for future use and reference. The organizing committee appreciates the interest shown in the review and the response by the authors in submitting these abstracts.

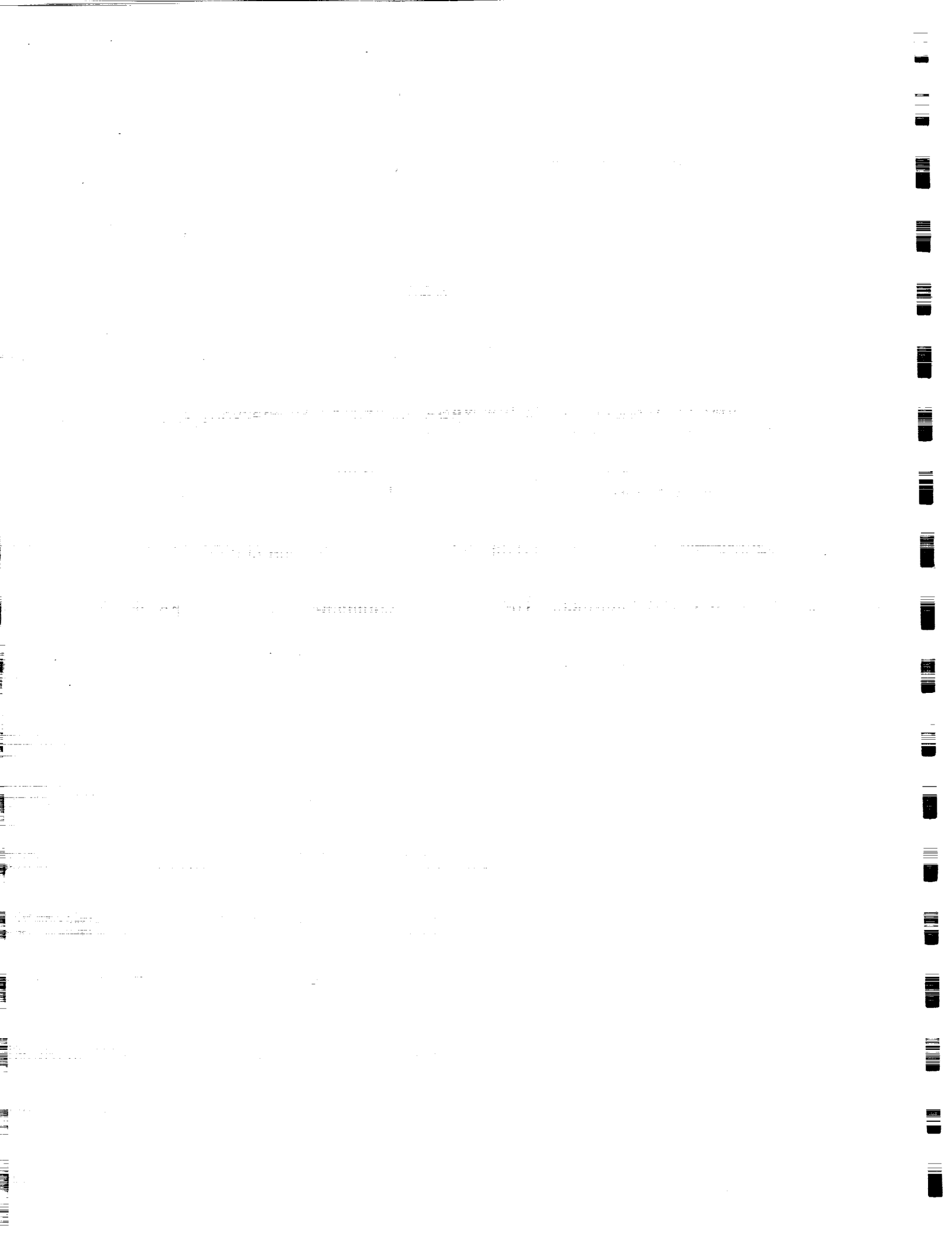

Automated Rendezvous & Capture Review

Abstract No.

Title

- 01 DEMONSTRATION OF AUTOMATED PROXIMITY AND DOCKING TECHNOLOGY
- 02 CARGO TRANSFER VEHICLE RCS PROPELLANT CONTAMINATION ISSUES
- 03 HYBRID NEURAL NETWORK AND FUZZY LOGIC APPROACHES FOR RENDEZVOUS & CAPTURE IN SPACE
- 04 AN AUTOMATED SYSTEM FOR SPACECRAFT PROXIMITY OPERATIONS
- 05 SIX DEGREE OF FREEDOM TEST FACILITY
- 06 A STRONGLY GOAL-ORIENTED CLOSE RANGE VISION SYSTEM FOR SPACECRAFT DOCKING
- 07 MANNED MANEUVERING UNIT APPLICATIONS FOR AUTOMATED RENDEZVOUS AND CAPTURE
- 08 MANNED VERSUS UNMANNED RENDEZVOUS AND CAPTURE
- 09 AUTONOMOUS RENDEZVOUS AND CAPTURE DEVELOPMENT INFRASTRUCTURE
- 10 NATIONAL LAUNCH SYSTEM OVERVIEW WITH FOCUS ON THE CARGO TRANSFER VEHICLE
- 11 AUTOMATED TECHNOLOGIES NEEDED TO PREVENT RADIOACTIVE MATERIALS FROM REENTERING THE ATMOSPHERE
- 12 AUTONOMOUS PREALIGNMENT OF A DOCKING MECHANISM
- 13 U.S. AUTOMATED RENDEZVOUS AND CAPTURE CAPABILITIES REVIEW REMOTE UMBILICAL SYSTEM ABSTRACT
- 14 AUTOMATED TARGET RECOGNITION AND TRACKING USING AN OPTICAL PATTERN RECOGNITION NEURAL NETWORK
- 15 APPLICABILITY OF RELATIVE GPS TO AUTOMATED RENDEZVOUS BETWEEN THE SPACE SHUTTLE AND SPACE STATION
- 16 AUTONOMOUS RENDEZVOUS AND DOCKING-A COMMERCIAL APPROACH TO ON-ORBIT TECHNOLOGY VALIDATION
- 17 REAL-TIME SIMULATIONS FOR AUTOMATED RENDEZVOUS AND CAPTURE
- 18 AUTONOMOUS RENDEZVOUS AND CAPTURE SYSTEM DESIGN
- 19 IMP, A PERFORMANCE CODE
- 20 CONTROL OF A VARYING THRUST SPACECRAFT FOR AUTONOMOUS SPACE RENDEZVOUS
- 21 LASER DOCKING SENSOR ENGINEERING MODEL
- 22 RENDEZVOUS STRATEGY IMPACTS ON CTV AVIONICS DESIGN, SYSTEM RELIABILITY REQUIREMENTS, AND AVAILABLE COLLISION AVOIDANCE MANEUVERS
- 23 THE REAL-TIME OPERATIONS OF THE SPACE SHUTTLE ORBITER DURING RENDEZVOUS AND PROXIMITY OPERATIONS
- 24 COHERENT DOPPLER LIDAR FOR AUTOMATED SPACE VEHICLE, RENDEZVOUS, STATION KEEPING AND CAPTURE
- 25 A SYNTHETIC ENVIRONMENT FOR VISUALIZATION AND PLANNING OF ORBITAL MANEUVERS
- 26 AUTONOMOUS RENDEZVOUS AND DOCKING OPERATIONS OF UNMANNED EXPENDABLE CARGO TRANSFER VEHICLE WITH SPACE STATION FREEDOM
- 27 TRAC BASED SENSING FOR AUTONOMOUS RENDEZVOUS
- 28 FLIGHT SUPPORT SYSTEM (FSS) DOCKING AND UMBILICAL SERVICES SYSTEMS
- 29 ON-BOARD FAULT MANAGEMENT FOR AUTONOMOUS SPACECRAFT
- 30 IMAGE BASED TRACKING APPROACHES TO AR&C AT THE JOHNSON SPACE CENTER
- 31 AUTOMATED RENDEZVOUS AND PROXIMITY OPERATIONS
- 32 "LADAR VISION TECHNOLOGY FOR AUTOMATED RENDEZVOUS AND CAPTURE"
- 33 A "PARC" SYSTEM FOR TERMINAL DOCKING
- 34 DESIGN AND FABRICATION OF AN AUTONOMOUS RENDEZVOUS AND DOCKING SENSOR USING OFF-THE-SHELF HARDWARE
- 35 VIRTUAL REALITY APPLICATIONS TO AUTOMATED RENDEZVOUS AND CAPTURE

1962

DEPARTMENT OF CHEMISTRY

PHYSICAL CHEMISTRY

LABORATORY

PHYSICAL CHEMISTRY

LABORATORY

LABORATORY

LABORATORY

LABORATORY

LABORATORY

LABORATORY

LABORATORY

LABORATORY

LABORATORY

LABORATORY

LABORATORY

LABORATORY

Automated Rendezvous & Capture Review

Abstract No.	<u>Title</u>
36	USE OF NON-SPHERICAL GRAVITY HARMONICS FOR RELATIVE MOTION GN&C
37	GN&C TRANSLATION AND ROTATION CONTROL PARAMETERS FOR AR&C
38	RESULTS OF PROTOTYPE SOFTWARE DEVELOPMENT FOR AUTOMATION OF SHUTTLE PROXIMITY OPERATIONS
39	SOVIET AUTOMATED RENDEZVOUS AND DOCKING SYSTEM OVERVIEW
40	ON-ORBIT DEMONSTRATION OF AUTOMATED CLOSURE AND CAPTURE USING EXISTING ESA-DEVELOPED PROXIMITY OPERATIONS TECHNOLOGIES AND AN EXISTING, SERVICABLE NASA EXPLORER PLATFORM SPACECRAFT
41	VIDEO GUIDANCE SENSOR FOR AUTONOMOUS CAPTURE
42	TALON AND CRADLE - SYSTEMS FOR THE RESCUE OF TUMBLING SPACECRAFT AND ASTRONAUTS
43	SPACE SHUTTLE PROGRAM - AUTOMATED RENDEZVOUS, PROXIMITY OPERATIONS, AND CAPTURE
44	CTV RENDEZVOUS TECHNIQUES
45	ON-ORBIT OPERATIONAL SCENARIOS, TOOLS AND TECHNIQUES
46	AN AUTONOMOUS RENDEZVOUS AND DOCKING SYSTEM USING CRUISE MISSILE TECHNOLOGIES
47	OPTICAL CORRELATORS FOR AUTOMATED RENDEZVOUS & CAPTURE
48	AUTOMATIC RENDEZVOUS & CAPTURE SYSTEM DEVELOPMENT IN A MANNED ENVIRONMENT
49	PERFORMANCE CAPABILITIES OF A "PHASE ONE" AUTOMATIC RENDEZVOUS AND CAPTURE SYSTEM
50	RELATIVE NAVIGATION REQUIREMENTS FOR AUTOMATIC RENDEZVOUS AND CAPTURE SYSTEMS
51	AUTOMATED RENDEZVOUS AND CAPTURE SYSTEM
52	A COMPARISON OF LASER BASED RANGING SYSTEMS FOR AR&C
53	NEW DEVELOPMENTS IN ASTRODYNAMICS ALGORITHMS FOR AUTONOMOUS RENDEZVOUS
54	ONBOARD NAVIGATION RENDEZVOUS EXPERT SYSTEM
55	AN OVERVIEW OF AUTONOMOUS RENDEZVOUS AND DOCKING SYSTEM TECHNOLOGY DEVELOPMENT AT GENERAL DYNAMICS
56	AUTONOMOUS DOCKING GROUND DEMONSTRATION
57	RENDEZVOUS RADAR FOR THE ORBITAL MANEUVERING VEHICLE
58	AUTONOMOUS RENDEZVOUS TARGETING TECHNIQUES FOR NATIONAL LAUNCH SYSTEM APPLICATION
59	INTELLIGENT SYSTEMS TECHNOLOGY INFRASTRUCTURE FOR INTEGRATED SYSTEMS
60	DGPS FOR SPACE AND RETURN
61	AN AUTOMATED RENDEZVOUS AND CAPTURE SYSTEM DESIGN CONCEPT FOR THE CARGO TRANSFER VEHICLE AND SPACE STATION FREEDOM
62	SUPERVISED AUTONOMOUS RENDEZVOUS AND DOCKING SYSTEMS
63	A NAVIGATION AND CONTROL SYSTEM FOR AN AUTONOMOUS RESCUE VEHICLE IN THE SPACE STATION ENVIRONMENT
64	OPTICAL PHASE MEASURING SENSORS FOR AUTOMATED RENDEZVOUS & CAPTURE
65	MAGNETIC END EFFECTORS FOR SPACE OPERATIONS
66	USE OF AUTOMATED RENDEZVOUS TRAJECTORY PLANNING TO IMPROVE SPACECRAFT OPERATIONS EFFICIENCY
67	AN INTEGRATED AUTONOMOUS RENDEZVOUS AND DOCKING SYSTEM ARCHITECTURE USING CENTAUR MODERN AVIONICS
68	COLLISION AVOIDANCE FOR CTV REQUIREMENTS AND CAPABILITIES
69	PILOTING DECISION AID FOR SPACECRAFT PROXIMITY OPERATIONS
70	SPACECRAFT RENDEZVOUS OPERATIONAL CONSIDERATIONS AFFECTING VEHICLE SYSTEMS DESIGN AND CONFIGURATION

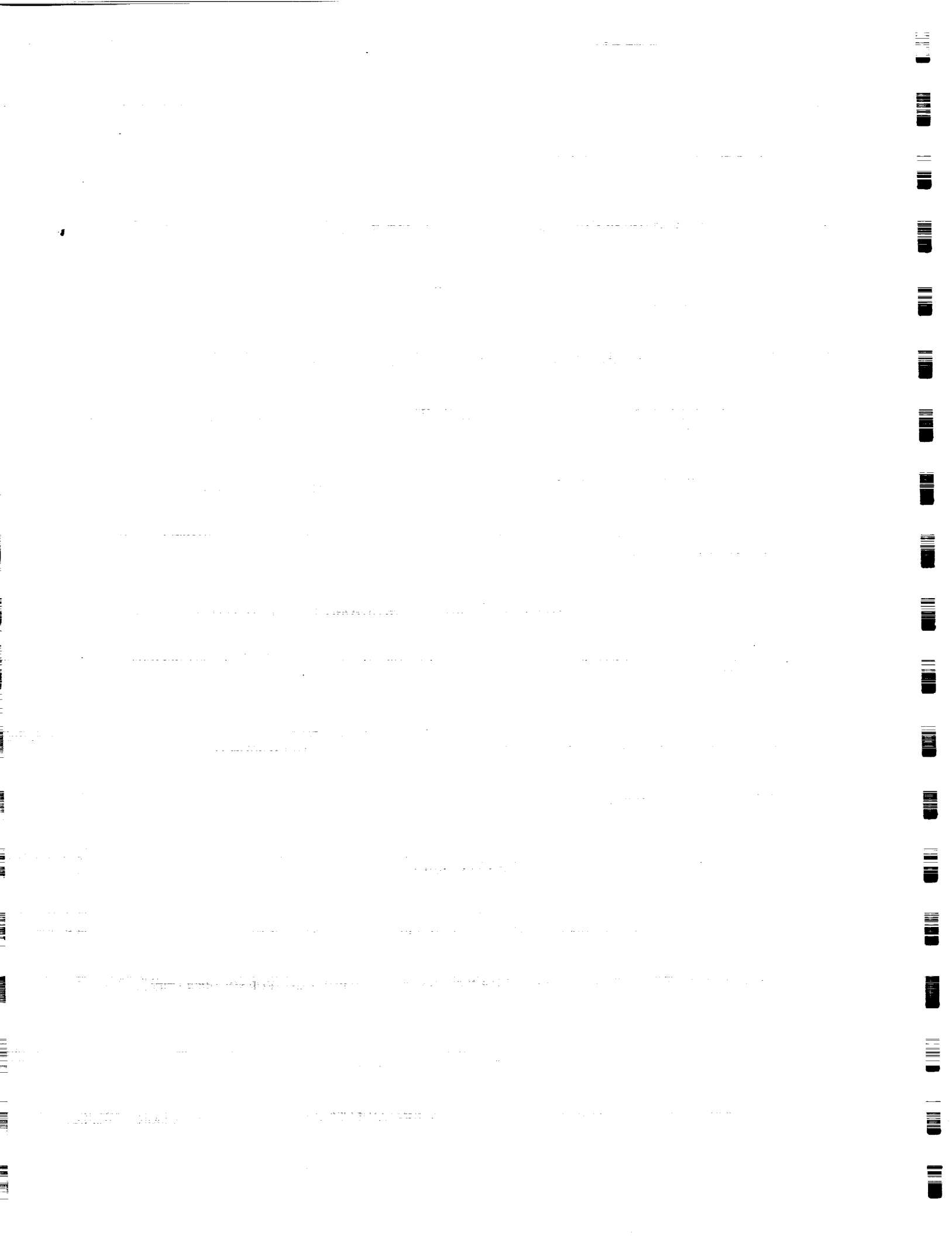

Automated Rendezvous & Capture Review

Abstract No.	Title
71	APPROACH RANGE AND VELOCITY DETERMINATION USING LASER SENSORS AND RETROREFLECTOR TARGETS
72	AUTOMATED RENDEZVOUS AND DOCKING WITH VIDEO IMAGERY
73	6DOF SIMULATION SYSTEM FOR EVALUATING AUTOMATED RENDEZVOUS AND DOCKING SPACECRAFT
74	PROPOSED CTV DESIGN REFERENCE MISSIONS IN SUPPORT OF SPACE STATION FREEDOM
75	OFFICE OF SPACE FLIGHT STANDARD SPACEBORNE GLOBAL POSITIONING SYSTEM USER EQUIPMENT PROJECT
76	THE DEVELOPMENT OF AN AUTONOMOUS RENDEZVOUS AND DOCKING SIMULATION USING RAPID INTEGRATION AND PROTOTYPING TECHNOLOGY
77	PHOTONIC CORRELATOR PATTERN RECOGNITION: APPLICATION TO AUTONOMOUS DOCKING
78	SIMULATION MODELS FOR AUTONOMOUS RENDEZVOUS AND CAPTURE
79	AUTOMATING AN ORBITER APPROACH TO SPACE STATION FREEDOM TO MINIMIZE PLUME IMPINGEMENT
80	CONTACT DYNAMICS TESTING OF AUTOMATED THREE POINT DOCKING MECHANISM
81	EXPERIMENTAL VALIDATION OF DOCKING AND CAPTURE USING SPACE ROBOTICS TESTBEDS
82	PROXIMITY OPERATIONS CONSIDERATIONS AFFECTING SPACECRAFT DESIGN
83	THE MSFC SPACE STATION/SPACE OPERATIONS MECHANISM TEST BED
84	THE ROLE OF SMART SYSTEMS IN RENDEZVOUS, CLOSE PROXIMITY OPERATIONS AND DOCKING MANEUVERS
85	GUIDELINE REQUIREMENTS FOR SERVICEABLE SPACECRAFT GRASPING/BERTHING/DOCKING INTERFACES BASED ON SIMULATIONS AND FLIGHT EXPERIMENTS
86	AUTOMATIC RENDEZVOUS SYSTEM TESTING AT THE FLIGHT ROBOTICS LABORATORY
87	THRUSTER CONFIGURATIONS FOR MANEUVERING HEAVY PAYLOADS
88	ELECTRO-OPTICAL RENDEZVOUS AND DOCKING SENSORS
89	CONCURRENT-SCENE/ALTERNATE PATTERN ANALYSIS FOR ROBUST VIDEO-BASED DOCKING SYSTEMS
90	AUTONOMOUS RECONFIGURABLE GPS/INS NAVIGATION AND POINTING SYSTEM FOR RENDEZVOUS AND DOCKING
91	A BERTHING AND FASTENING STRATEGY FOR ORBITAL REPLACEMENT UNITS
92	FULLY AUTONOMOUS NAVIGATION FOR THE NASA CARGO TRANSFER VEHICLE
93	EMPLOYING LIGHTING TECHNIQUES DURING ON-ORBIT OPERATIONS
94	METHODS FOR MODELING CONTACT DYNAMICS OF CAPTURE MECHANISMS
95	AR&D IMAGE PROCESSING SYSTEM

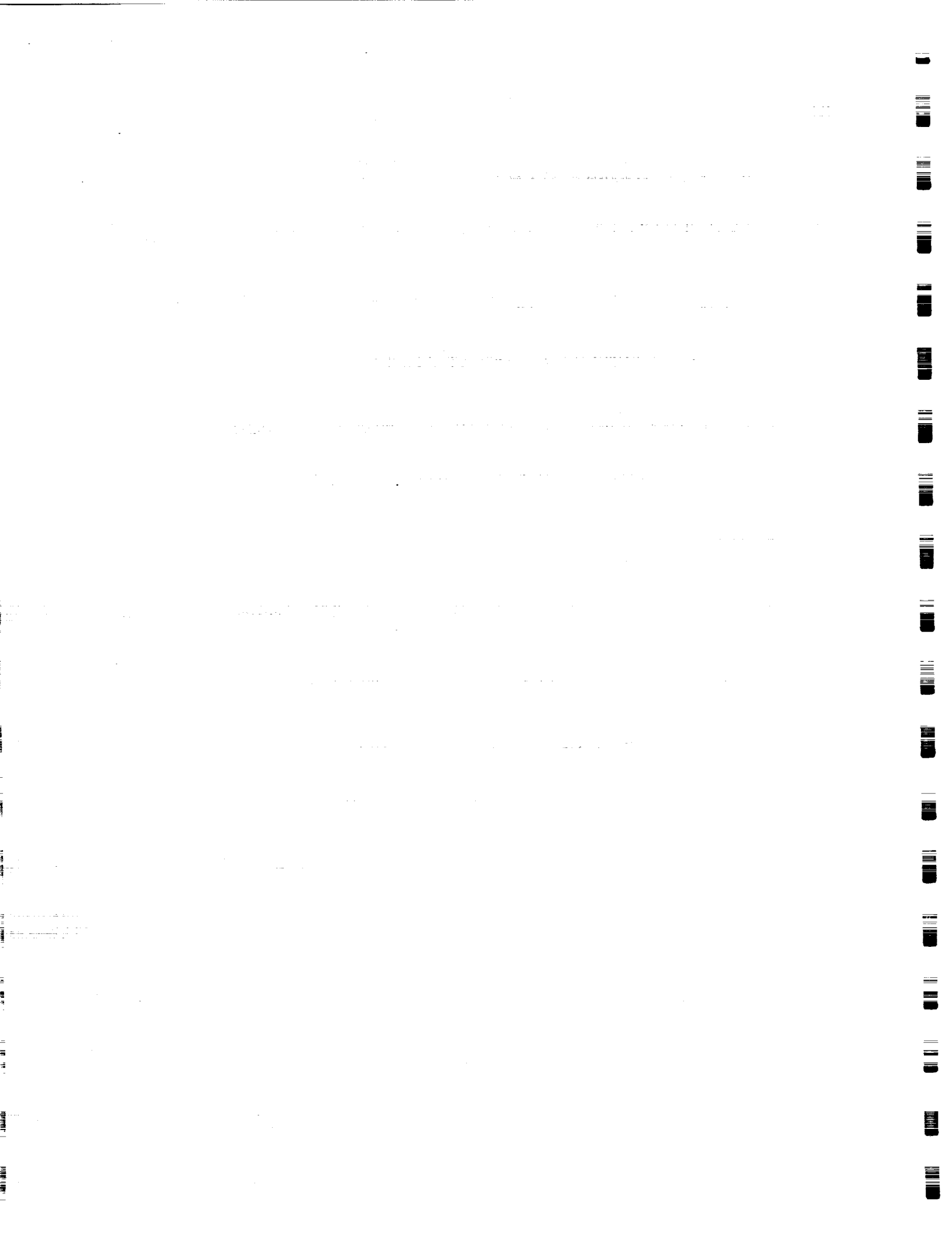

DEMONSTRATION OF AUTOMATED PROXIMITY AND DOCKING TECHNOLOGY

Robert L. Anderson
Roy K. Tsugawa



Federal Systems Division
1 Space Park Bldg. R11/2337
Redondo Beach, CA 90278
(213)812-2630 Phone
(213)812-8016 FAX

Thomas C. Bryan
NASA
MSFC EB24
Huntsville, AL 35812
(205)544-3550 Phone
(205)544-3801 FAX

SI-13
HBS ONLY
146712
P-2

Statement of technical details of the capability being described

Automated spacecraft docking operations are being performed using a full scale motion based simulator and an optical sensor. This presentation will discuss the work in progress at TRW and MSFC facilities to study the problem of automated proximity and docking operations. The docking sensor used is the MSFC Optical Sensor and simulation runs are performed using the MSFC Flat Floor Facility. The control algorithms and six degree of freedom (6DOF) simulation software were developed at TRW and integrated into the MSFC facility.

Key issues being studied are the quantification of docking sensor requirements and operational constraints necessary to perform automated docking maneuvers, control algorithms capable of performing automated docking in the presence of sensitive and noisy sensor data, and sensor technologies for automated proximity and docking operations. As part of this study the MSFC sensor characteristics were analyzed and modeled so that off line simulation runs can be performed for control algorithm testing. Our goal is to develop and demonstrate full 6DOF docking capabilities with actual sensors on the MSFC motion based simulator.

We present findings from actual docking simulation runs which show sensor and control loop performance as well as problem areas which require close attention. The evolution of various control algorithms using both phase plane and Clohessy-Wiltshire techniques will be discussed. In addition, 6DOF target acquisition and control strategies will be described.

History of the origins and evolution of the capability

The initial 6DOF automated control laws were developed and integrated into the motion based simulator at the MSFC Flight Robotics Laboratory in 1989. Since then, added capabilities and new algorithms have continued to be added to the system. The motion based simulation system allows the integration and closed loop demonstration of automated docking system components such as docking sensors, control algorithms, and operational groundrules. Through the use of this facility, we have refined and validated our automated docking system concepts and requirements.

The level of maturity of the capability

The motion based simulation facility is fully functional and has been in use each year since its inception. It provides a very powerful testbed for developing and evaluating sensor designs and validating mission design parameters and onboard computer algorithms. As automated docking components are developed, they are tested and validated using the motion based simulation facility.

Test experience and/or experimental results

The motion based simulations have provided a wealth of data for establishing autodocking and automated proximity operations system requirements. The results of our testing have allowed the characterization of the optical docking sensor performance and has enabled a more robust, higher performance docking sensor design to be created. The experimental results have also contributed to the evolution and design of the control algorithms and operational procedures for automated docking. Based on our findings, we conclude that automated docking is a viable capability which can be implemented using current technology.

Source/sponsorship and current funding estimates

Over the past several years TRW has continued to invest in the development of automated proximity and docking technologies. We are currently addressing key issues that will result in a mature, automated proximity and docking capability.

Cargo Transfer Vehicle RCS Propellant Contamination Issues

by
Richard O. Ballard
Sverdrup Technology / MSFC Group

S2-28
NBS. SNLY
146713

ABSTRACT

P. 1

The purpose of this report is to address CTV RCS contamination issues and contribute to the resources necessary to optimize the vehicle and propulsion systems required in the Cargo Transfer Vehicle (CTV) of the National Launch System (NLS) Heavy Lift Launch Vehicle (HLLV). This study reviews the thruster-induced contaminants; their transportation from the thrust chamber to the vehicle, payload, and SSF; and the mechanism by which damage is inflicted on their components.

The effect of both monopropellant and bipropellant RCS rocket exhaust plumes on a spacecraft and related functional surfaces has been the subject of considerable study over the years. It is recognized that the RCS rocket produces contaminants which can significantly degrade the performance of optical windows, solar cells, thermal-protective coatings and other external vehicle components. This is particularly true when the rocket is operating in the pulse mode. The exhaust plume impingement pressure and heat-transfer phenomena also complicate the environment to which the vehicle and its functional surfaces are exposed, but are not addressed in this study.

Bipropellant contamination presented several modes of damage to incident surfaces, which can pose a long-term deleterious consequence to CTV payloads and the Space Station Freedom (SSF). Monopropellant contamination did not pose any significant long-term issues other than the possibility of aniline deposition. The use of either bipropellant and monopropellant propulsion systems can have a design impact on the CTV propulsion system with respect to maneuvering operations in the proximity of SSF.

SECRET

TO: SAC, NEW YORK (100-100000) FROM: SAC, PHOENIX (100-100000)

RE: [Illegible]

PHOENIX TELETYPE TO NEW YORK, 1/15/68

PHOENIX TELETYPE TO NEW YORK, 1/15/68

PHOENIX TELETYPE TO NEW YORK, 1/15/68

PHOENIX TELETYPE TO NEW YORK, 1/15/68

PHOENIX TELETYPE TO NEW YORK, 1/15/68

PHOENIX TELETYPE TO NEW YORK, 1/15/68

PHOENIX TELETYPE TO NEW YORK, 1/15/68

PHOENIX TELETYPE TO NEW YORK, 1/15/68

PHOENIX TELETYPE TO NEW YORK, 1/15/68

PHOENIX TELETYPE TO NEW YORK, 1/15/68

PHOENIX TELETYPE TO NEW YORK, 1/15/68

PHOENIX TELETYPE TO NEW YORK, 1/15/68

PHOENIX TELETYPE TO NEW YORK, 1/15/68

SECRET

53-63

ABS. ONLY

146714

N 93 - 22229

Hybrid Neural Network and Fuzzy Logic Approaches for Rendezvous and Capture in Space

Hamid R. Berenji*
Timothy Castellano
Artificial Intelligence Research Branch
NASA Ames Research Center
MS: 244-17, Mountain View, CA 94035
e-mail: berenji@ptolemy.arc.nasa.gov, castellano@ptolemy.arc.nasa.gov

1 Background

The non-linear behavior of many practical systems and unavailability of quantitative data regarding the input-output relations makes the analytical modeling of these systems very difficult. On the other hand, approximate reasoning-based controllers which do not require analytical models have demonstrated a number of successful applications such as the subway system in the city of Sendai [5]. These applications have mainly concentrated on emulating the performance of a skilled human operator in the form of linguistic rules. However, the process of learning and tuning the control rules to achieve the desired performance remains a difficult task.

Fuzzy Logic Control is based on fuzzy set theory [6]. A fuzzy set is an extension of a crisp set. Crisp sets only allow full membership or no membership at all, whereas fuzzy sets allow partial membership. In other words, an element may partially belong to a set.

2 Rendezvous and Capture

The Space Exploration Initiative mission architectures outlined in the Synthesis Group Report (Stafford report) call for the development of autonomous rendezvous and docking techniques as a critical technology. The National launch System program is sponsoring a workshop to investigate the technology readiness level of the technology in support of the cargo transfer vehicle element of the National Launch System.

To date the US has no experience whatsoever in this field although extensive research has been carried out. The Soviets have been employing AR&D since 1967 with their unmanned Progress tankers that resupply the Mir space station with consumables. Autonomous is

*Sterling Federal Systems

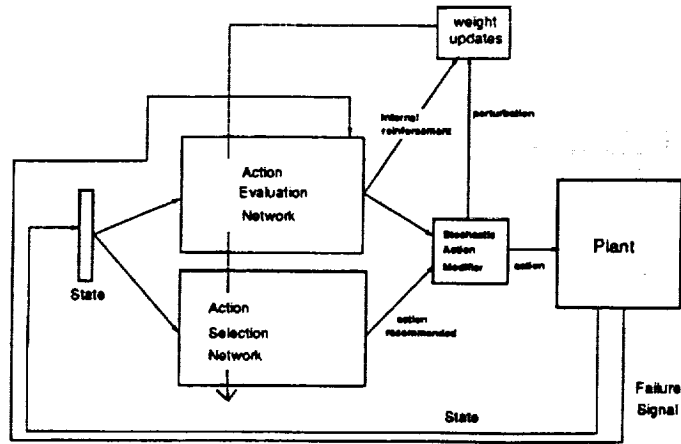

Figure 1: The Architecture of GARIC.

defined in this context as closed loop control onboard one of the two vehicles (target or chaser) without ground intervention or onboard operator control.

3 Approach

A true systems approach will be undertaken to explore and expand AR&D mission requirements based on program high level goals. A study of Soviet practical flight experience and US research efforts will be undertaken to set a framework for the requirements analysis and system level trade studies.

Once conventional techniques are understood, an evaluation will be made of advanced artificial intelligence techniques such as GARIC (Generalized Approximate Reasoning-based Intelligent Control) architecture [3] which has been developed at Ames for potential application in this domain. GARIC determines a control action by using a neural network which implements fuzzy logic inference. In this way, prior expert knowledge can be easily incorporated. This knowledge is allowed to be faulty or damaged. Another neural net will learn to become a good evaluator of the current state and will serve as an internal critic. Both networks will adapt their weights concurrently so as to improve performance. The architecture of GARIC is schematically shown in Figure 1. It has three components:

- The Action Selection Network maps a state vector into a recommended action, using fuzzy inference.
- The Action Evaluation Network maps a state vector and a failure signal into a scalar score which indicates state goodness. This is also used to produce internal reinforcement.
- The Stochastic Action Modifier uses both the selected action and the internal reinforcement to produce an action which is applied to the plant.

Our recent experience [1] in applying a hybrid neural network and fuzzy logic control architecture [2] to a fuzzy logic controller developed at Johnson Space Center (JSC) for attitude control of the space shuttle [4], will assist us in evaluating GARIC for rendezvous and capture.

Advanced techniques have the potential for providing a more robust operational system that may safely dock in the presence of hardware faults or unanticipated conditions. The relative merits of these systems will be evaluated. The impact of the chosen technique on the entire vehicle system will be evaluated including hardware, operations, mass, power, communication, tracking, consumable expenditures etc.

Collaborations with scientists and engineers throughout the Information Sciences, Human Factors and Flight Systems and Simulation Division of the Aerospace Systems Directorate of NASA Ames Research Center is anticipated because of the tremendous in house expertise of these organizations.

Long term Goals A software simulation and or hardware docking simulation that allows the evaluation of various techniques will be developed based on tools used by the flight dynamics organization at JSC.

References

- [1] H. Berenji, Y. Jani, and R. Lea. Approximate reasoning-based learning and control for proximity operations and docking in space. In *AIAA Guidance, Navigation and Control Conference*, New Orleans, Louisiana, August 12-14, 1991.
- [2] H.R. Berenji. An architecture for designing fuzzy controllers using neural networks. *International Journal of Approximate Reasoning*, 1991 (in press).
- [3] H.R. Berenji and P. Khedkar. Learning and tuning fuzzy logic controllers through reinforcements. (*Under review for journal publication*), 1991.
- [4] R. Lea, J. Hoblit, and Y. Jani. Performance comparison of a fuzzy logic based attitude controller with the shuttle on-orbit digital auto pilot. In *North American Fuzzy Information Processing Society*. Columbia, Missouri, May 1991.
- [5] S. Yasunobu and S. Miyamoto. Automatic train operation by predictive fuzzy control. In M. Sugeno, editor, *Industrial Applications of Fuzzy Control*, pages 1-18. North-Holland, Amsterdam, 1985.
- [6] L. A. Zadeh. Fuzzy sets. *Information and Control*, 8:338-353, 1965.

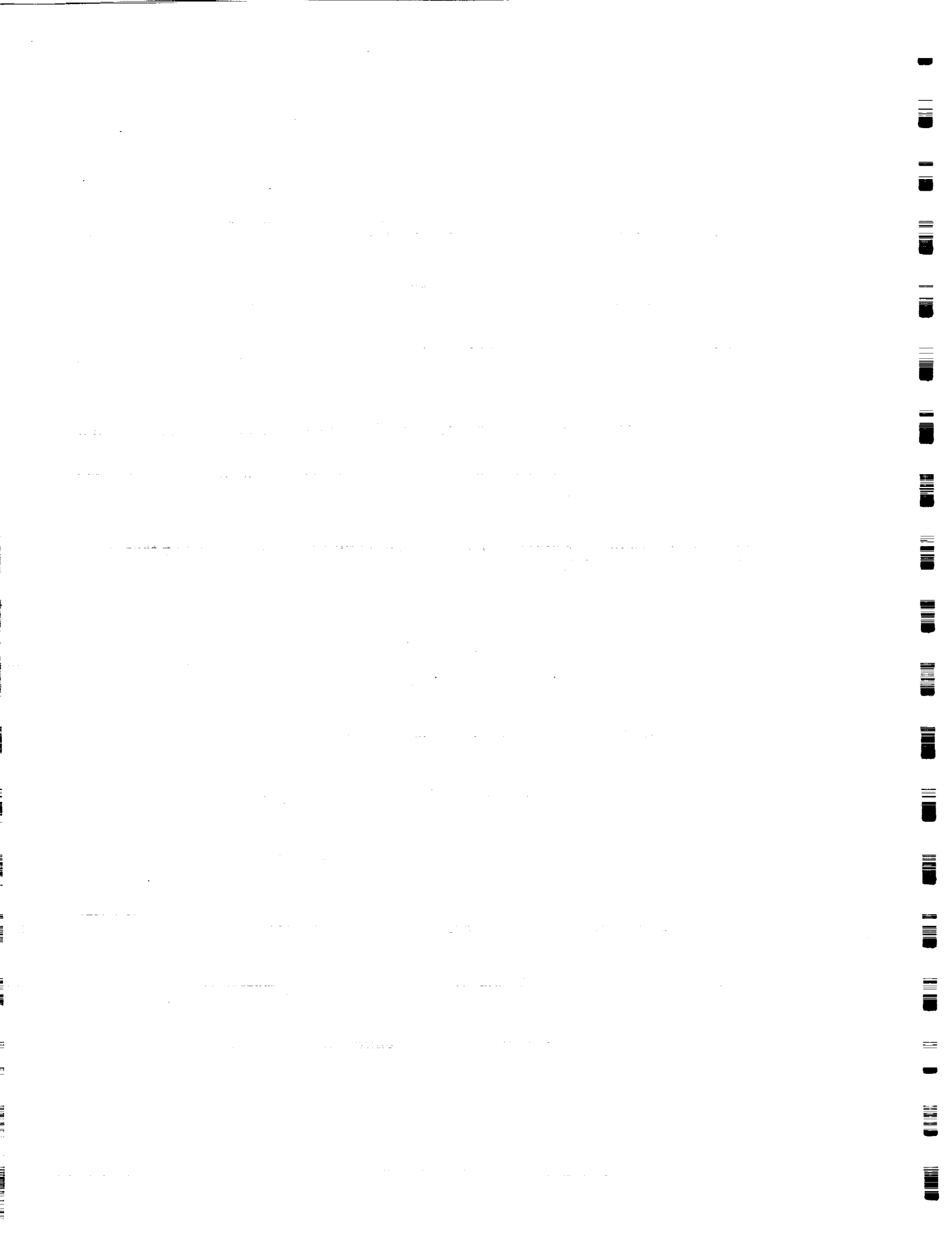

54-18
HAS ONLY
N 93 - 22230
P 3

**AN AUTOMATED SYSTEM
FOR SPACECRAFT PROXIMITY OPERATIONS**

E. Bergmann
The Charles Stark Draper Laboratory, Inc.

With the advent of multiple-vehicle operations in support of the space station, on-orbit refurbishment, and several other missions, there is a need to intelligently plan proximity operations trajectories that will conserve limited available fuel while avoiding collisions. Upon reaching the objective, the capture process entails several unique considerations, such as coordinating motion with a tumbling target, the capture itself, and adapting to control of the new configuration resulting from the capture operation. This paper outlines a systematic process of technical development over several years at the Draper laboratory, culminating in a capability to perform manual augmented or fully autonomous rendezvous, capture, and control of the resulting configuration.

This proximity operations system incorporates five main elements: a sequencing function, an automated proximity operations planner and execution system, a plume impingement and collision avoidance algorithm, the grapple system, and an adaptive autopilot. The grapple system will not be addressed here.

The A* node search method has been chosen for the proximity operations trajectory planner for several reasons. By its nature, the A* algorithm can develop the most fuel efficient trajectory while avoiding obstacles or other constraints. The A* algorithm is more global than gradient search methods in its optimization, and it is much less likely to converge on a local minimum. Because of these factors, the A* algorithm is a good approach to the proximity operations trajectory planning problem.

For reaction control vehicles, a finite number of effectors and variations in mass properties imply that control authority is a function of direction. The Shuttle, for example, has more control authority in roll than in pitch or yaw, and has more control authority in z than in -x. Relative authority levels also can change significantly with a change in mass properties, jet failures, or deselection of jets to avoid plume impingement. The actual geometry of the relative control authority can be hard to visualize, and only in rare circumstances is the maximum control authority aligned with the body axes.

The conventional assumption of uniform control authority may result in very costly trajectories compared to optimal trajectories. The planner must incorporate substantial information from the autopilot to take best advantage of the vehicle effectors in performing proximity operations. An adaptive autopilot, based on a system successfully flight tested on

Shuttle, is used with the planner. This autopilot is capable of operating complex and changing reaction control jet configurations to obtain fuel optimal control. It is through this autopilot that the system gains the ability to handle jet failures, changing mass properties and deselection of jets to avoid plume impingement.

A spacecraft must avoid contacting other vehicles or obstacles as it performs its maneuvers. With simple, compact vehicles (such as the Apollo spacecraft), it was not difficult to find docking trajectories that would avoid vehicle collisions. However, with more complicated vehicle shapes or multiple vehicles, attaining mission objectives while avoiding collisions becomes a more challenging problem. A collision avoidance algorithm is incorporated into the system to avoid undesired contact between the vehicle and target. As a byproduct of this process, plume impingement on the target can be anticipated and jets deselected to avoid such impingement.

After grappling the target, the attitude control system must stabilize the new configuration. If the target is significant in size and mass properties relative to the active vehicle, this may entail significant accommodation. The control authorities will change significantly, and several jets may be inhibited to avoid plume impingement. The previously mentioned adaptive autopilot is capable of meeting both needs if the properties of the new configuration are known. A mass property identification scheme has also been incorporated into the system for the case where the target is uncertain, or the target is grappled in an orientation other than anticipated. This algorithm "learns" the new configuration mass properties by comparing anticipated and actual vehicle response to jet firings. This information is then used by the autopilot to maintain efficient control of the new configuration.

The effectiveness of the proximity operations system was demonstrated on the Draper Space Systems Simulator. The Space Systems Simulator is a high-fidelity simulation of on-orbit motion of two vehicles. The space systems simulator independently integrates the equations of motion in six degrees of freedom using a fourth order Runge-Kutta algorithm. The outputs of the Space Systems Simulator include plots of each component of the vehicle state and fuel use. The simulator also has the capability of graphically depicting the maneuver as it is executed from any point of view or viewing distance.

There are several potential uses for the system. First, it could be used prior to flight to assist in flight planning by providing suggested trajectories that may not otherwise be obvious. The system could also be used on the ground during mission contingencies. If, for example, a jet unexpectedly fails, the system could be used to help obtain an alternate trajectory more quickly than might be possible using other methods.

When sufficient confidence is gained in the system, it could be used as a "pilot's associate," implemented onboard. When a situation arises for

which a clear plan of action is not apparent, the pilot's associate could develop alternative plans, subject to current objectives and constraints for the pilot to evaluate. The pilot could then either follow the plan, or allow the system to execute it automatically.

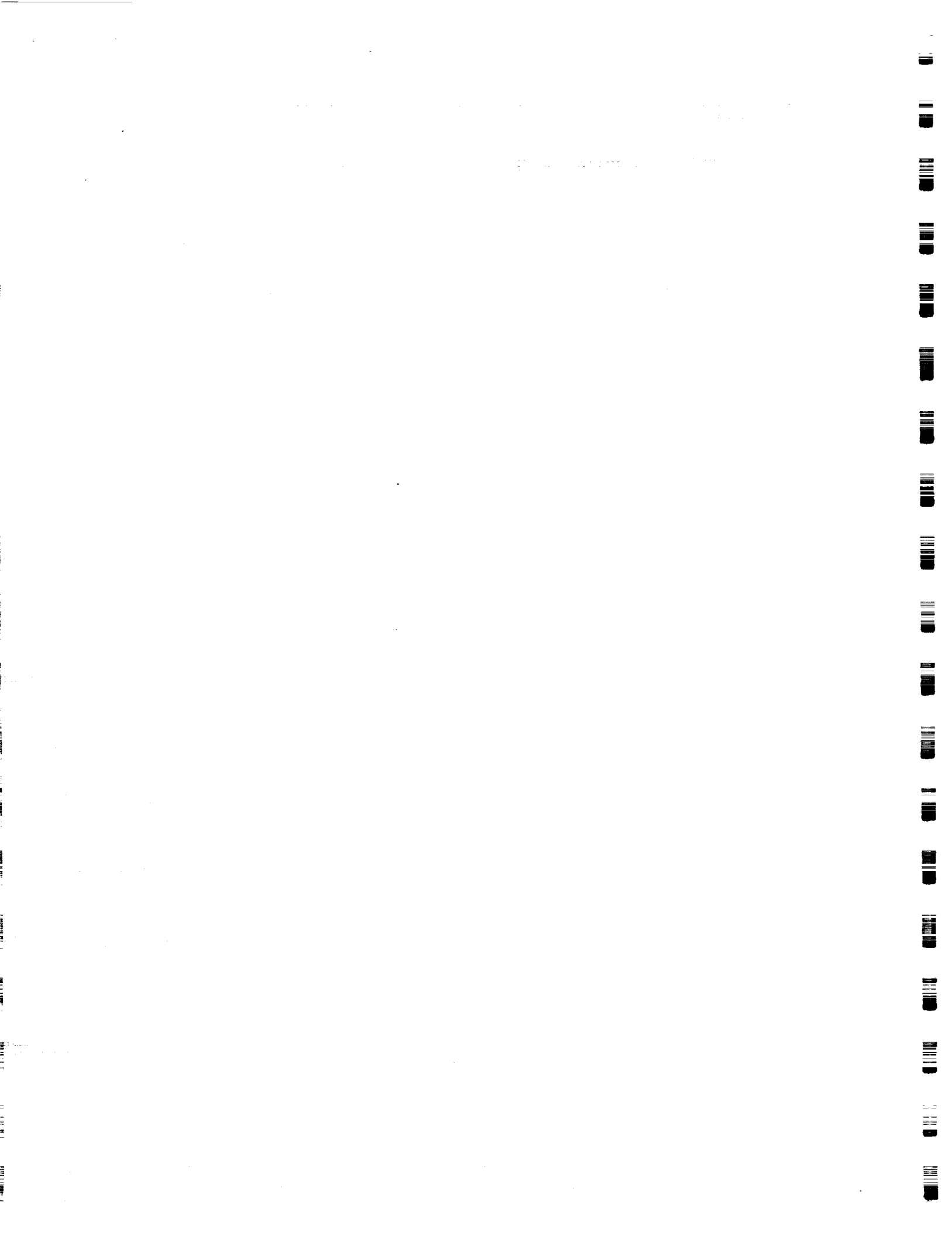

ABSTRACT TITLE: Six-Degree of Freedom Test Facility

AUTHOR: Michelle A. Bittel

AFFILIATION: Lockheed Engineering & Sciences Company

TELEPHONE/FAX: (713) 483-7492/(713) 483-5830

55-14
ABS ONLY
146716
N 93 - 22231

Shuttle to Space station docking has become an important issue in the last few years. Docking sensors have been proposed that will provide high precision measurements required for the fuel efficient rendezvous and docking of space vehicles. These sensors will also be used for satellite servicing and orbital assembly. The performance of the docking sensors must be tested before they are implemented in a space environment. A Six-Degree-of-Freedom(6-DOF) Test Facility has been developed at the Tracking & Communications Section, Johnson Space Center to test the static and dynamic accuracies of docking sensors. A candidate sensor is evaluated by comparing the sensor's static position and velocity measurements to the more accurate 6-DOF system.

The hardware comprising the facility is very robust. An air-bearing 12-meter granite rail system highlights the system. Five rotary stages provide rotational movement. Additional hardware supporting the facility include a Global Positioning System (GPS) Time Receiver, a rate meter, and a metrology system. A centralized computer with associated software controls the facility. The 6-DOF facility can provide one degree of translation (range) and five degrees of rotation (bearing angles and attitude). Range accuracies are 10.0 microns/meter while rotational accuracies are +/- 0.001 degrees.

The 6-DOF Test Facility's hardware is fully integrated. Software has been developed in-house to support system operation. The system has been tested statically and the operational parameters verified. System accuracies remain to be determined. Dynamic testing of the facility is expected to begin shortly. Several companies such as McDonnell Douglas, Autonomous Technologies, and General Dynamics, are scheduled to test sensors in the next few months. The 6-DOF facility will be available for use in November 1991.

This presentation will describe the subcomponents, operation, and capabilities of the 6-DOF Test Facility. Discussions will be held on system accuracies. Additional applications of the 6-DOF system will also be addressed.

1. The first part of the document discusses the importance of maintaining accurate records of all transactions and activities. It emphasizes the need for transparency and accountability in financial reporting.

2. The second part of the document outlines the various methods and techniques used to collect and analyze data. It includes a detailed description of the experimental procedures and the tools used for data collection.

3. The third part of the document presents the results of the study, including a comparison of the different methods and techniques used. It discusses the strengths and weaknesses of each method and provides a summary of the findings.

4. The fourth part of the document discusses the implications of the study and provides recommendations for future research. It highlights the need for further investigation into the effectiveness of the different methods and techniques used.

5. The fifth part of the document provides a conclusion and a summary of the key findings. It reiterates the importance of maintaining accurate records and the need for transparency and accountability in financial reporting.

6. The sixth part of the document provides a list of references and a bibliography. It includes a list of all the sources used in the study and provides a detailed description of each source.

7. The seventh part of the document provides a list of appendices and a bibliography. It includes a list of all the appendices used in the study and provides a detailed description of each appendix.

8. The eighth part of the document provides a list of figures and a bibliography. It includes a list of all the figures used in the study and provides a detailed description of each figure.

9. The ninth part of the document provides a list of tables and a bibliography. It includes a list of all the tables used in the study and provides a detailed description of each table.

10. The tenth part of the document provides a list of references and a bibliography. It includes a list of all the sources used in the study and provides a detailed description of each source.

56-74
ABS ONLY
N 93-22232
p. 3

A Strongly Goal-Directed Close-Range Vision System for Spacecraft Docking

K. L. BOYER
Signal Analysis & Machine Perception Laboratory
Department of Electrical Engineering
The Ohio State University
Columbus, OH 43210
kim@ee.eng.ohio-state.edu
(614) 292-7947; FAX 292-7596

R. E. GODDARD
Jet Propulsion Laboratory
California Institute of Technology
Pasadena, CA 91109
goddard@csi.jpl.nasa.gov
(818) 354-0415; FAX 393-4440

Abstract

In this presentation we will propose a strongly goal-oriented stereo vision system to establish proper docking approach motions for automated rendezvous and capture (AR&C). From an input sequence of stereo video image pairs, the system produces a current best estimate of:

- Contact position
- Contact vector
- Contact velocity
- Contact orientation

The processing demands imposed by this particular problem and its environment dictate a special case solution; such a system should necessarily be, in some sense, minimalist. By this we mean the system should construct a scene description just sufficiently rich to solve the problem at hand and should do no more processing than is absolutely necessary. In addition, the imaging resolution should be just sufficient. Extracting additional information and constructing higher level scene representations wastes energy and computational resources and injects an unnecessary degree of complexity, increasing the likelihood of malfunction. We therefore take a departure from most prior stereopsis work, including our own, and propose a system based on associative memory. The purpose of the memory is to immediately associate a set of motor commands with a set of input visual patterns in the two cameras. That is, rather than explicitly computing point correspondences and object positions in world coordinates and trying to reason forward from this information to a plan of action, we are trying to capture the essence of *reflex behavior* through the action of associative memory. The explicit construction of point correspondences and 3D scene descriptions, followed by online velocity and point of impact calculations, is prohibitively expensive from a computational point of view for the problem at hand. Learned patterns on the four image planes, left and right at two discrete but closely spaced instants in time, will be used directly to infer the spacecraft reaction. This will be a continuing online process as the docking collar approaches.

The essential concept behind an associative memory implementation of reflexive behavior is this. We will store some sizeable set of reference patterns derived from possible input image

foursomes. Each of these patterns will describe a physical configuration of the domain of responsibility for the memory. For our purposes, the description of the configuration of this domain should include whether or not a viable docking position is present and, if so, what its current relative position and velocity vectors are. This does not mean that we need to compute position and velocity explicitly. Rather, it means that the patterns we extract should implicitly contain that information. The set of patterns we store should effectively cover the domain of responsibility; holes in the coverage will correspond to windows of vulnerability for the spacecraft; appropriate action is impossible if the physical configuration of the domain of responsibility is not recognized. Associated with each pattern is information specifying the appropriate reflexive action based on the current state of the environment.

The presentation will discuss the following issues:

- System Design Criteria and Assumptions
- System Design Specifics (an example)
 - Pattern Construction and Imaging Resolution
 - Selecting the Reference Patterns: General Principles
 - Selecting the Reference Patterns: Specifics
 - Physical Constraints: Limiting the Choices
 - Accuracy Considerations
 - Counting the Reference Pattern Set
 - Total Memory Size and Topological Structure

The background for this work is the extensive prior work of the first and second authors in computer vision and robotics, respectively. We have conducted a design feasibility study for the related problem of robotic avoidance, retreat, or resistance to an incoming airborne projectile. In that particular example, we were able to design a system storing 100,000 patterns, each having 44 bits for the reference pattern and 20 bits to specify the necessary action. The resulting associative memory capacity requirement was about 800KBytes, which is certainly reasonable. Of course, that problem is different in many respects than the AR&C problem, but the result is encouraging.

Finally, we offer a few comments about topological structuring. Since the image foursomes are built from overlapping pairs (the second pair of one foursome is the first pair of the next) we can immediately restrict our attention to that portion of the memory containing reference patterns whose "heads" approximate the current "tail." Additionally, we can restrict the search within this region to that subregion containing those patterns whose tails are possible (or most likely) given physical constraints on motion and disparity changes. The memory should be organized to take advantage of this natural structure. This is an area of ongoing study, as are the crucial accuracy issues.

Selected References

1. R. E. Goddard, K. L. Boyer, and H. H. Hemami, "Collision Strategies for Robotic Retreat and Resistance," to appear in *Microprocessors in Robotic and Manufacturing Systems*, S. G. Tzafestas, (ed.) Kluwer Academic Publishers, 1991.
2. R. C. Nelson, "Visual Homing Using an Associative Memory," *Proceedings of the DARPA Image Understanding Workshop*, pp. 245-262, 1989.
3. S. Sarkar and K. L. Boyer, "On Optimal Infinite Impulse Response Edge Detection Filters," *IEEE Transactions on Pattern Analysis and Machine Intelligence*, Vol. 13, No. 11, November 1991 (in press)
4. S. Sarkar and K. L. Boyer, "Optimal Infinite Impulse Response Zero Crossing Based Edge Detectors," *CVGIP: Image Understanding*, Vol. 54, No. 2, pp. 224-243, September 1991.
5. D. H. Ballard and A. Ozcandarli, "Eye Fixation and Early Vision: Kinetic Depth," *Proceedings Second International Conference on Computer Vision*, pp. 524-531, 1988.
6. S. V. Raman, S. Sarkar, and K. L. Boyer, "Tissue Boundary Refinement in Magnetic Resonance Images Using Contour-Based Scale Space Matching," *IEEE Transactions on Medical Imaging*, Vol. 11, No. 2, pp. 109-121, June 1991.
7. K. L. Boyer, G. E. Sotak, and A. F. Schenk, "Structural Stereopsis: Potential for Automatic Stereo Camera Calibration," *Optical Engineering*, Vol. 30, No. 3, pp. 288-299, March 1991.
8. D. M. Wuescher and K. L. Boyer, "Robust Contour Decomposition Using a Constant Curvature Criterion," *IEEE Transactions on Pattern Analysis and Machine Intelligence*, Vol. 13, No. 1, pp. 41-51, January 1991.
9. K. L. Boyer, D. M. Wuescher, and S. Sarkar, "Dynamic Edge Warping: Recovering Disparity Maps in Weakly Constrained Systems," *IEEE Transactions on Systems, Man, and Cybernetics*, Vol. 21, No. 1, pp. 143-158, January/February 1991.
10. K. L. Boyer and A. C. Kak, "Structural Stereopsis for 3D Vision," *IEEE Transactions on Pattern Analysis and Machine Intelligence*, Vol. 10, pp. 144-166, March 1988.

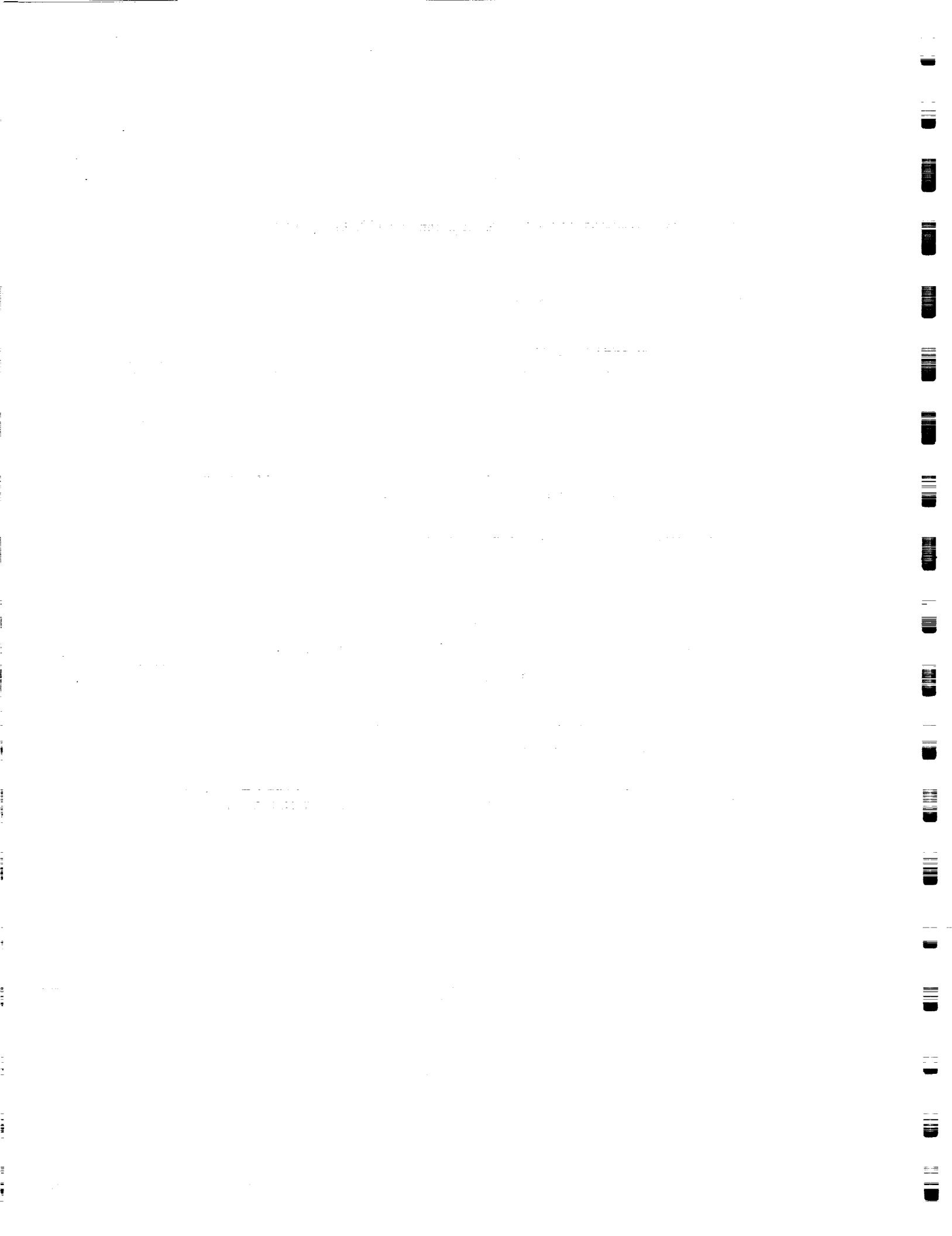

57-18
1135.0047

**MANNED MANEUVERING UNIT APPLICATIONS
FOR**

AUTOMATED RENDEZVOUS AND CAPTURE N 93-22233

**DONALD L. BREHM, JOHN A. CUSEO, JOSEPH A. LENDA, LEX RAY
MARTIN MARIETTA ASTRONAUTICS GROUP**

**C. EDWARD WHITSETT
NASA, JOHNSON SPACECRAFT CENTER**

Background

Automated Rendezvous and Capture (AR&C) is an important technology to multiple National Aeronautics and Space Administration (NASA) programs and centers. The recent Johnson Spacecraft Center (JSC) AR&C Quality Function Deployment (QFD) has listed **on-orbit demonstration** of related technologies as a near term priority. Martin Marietta has been evaluating use of the Manned Maneuvering Unit (MMU) for a low cost near term on-orbit demonstration of AR&C technologies such as control algorithms, sensors and processors as well as system level performance.

The MMU Program began in 1979 as the method of repairing the Space Shuttle (STS) Thermal Protection System (the Tiles). The units were not needed for this task, but were successfully employed during three (3) Shuttle flights in 1984: a test flight was flown in February as proof of concept, in April the MMU participated in the Solar Max Repair Mission, and in November the MMUs returned to space to successfully rescue the two (2) errant satellites, Westar and Palapa. In the intervening years, the MMU simulator and MMU Qualification Test Unit (QTU) have been used for Astronaut training and experimental evaluations. The Extra-Vehicular Activities (EVA) Retriever has used the QTU, in an unmanned form, as a free-flyer on the Johnson Space Center (JSC) Precision Air Bearing Floor (PABF).

Currently, the MMU is undergoing recertification for flight. The two (2) flight units were removed from storage in September, 1991 and evaluation tests were performed. The tests demonstrated that the units are in good shape with no discrepancies that would preclude further use. The Return to Flight effort is currently clearing up recertification issues and evaluating the design against the present Shuttle environments.

MMU Applications for Automated Rendezvous and Capture

The Manned Maneuvering Unit can be used as a controlled free-flying platform for AR&C experiments outside the Shuttle Cargo Bay. One concept involves a foot locker sized (approximately - 23 x 23 x 40 inches and 450 lbs.) avionics package attached to the MMU, similar in size and mass to the IMAX camera canister, containing docking sensors, processors, batteries, and a data recorder and/or transceiver. Adequate control authority exists on the MMU to allow for the installation of the module between the control arms. An interface between the avionics package and the MMU through the hand controllers and ground test connectors can be made, so that the MMU propulsion and control electronics systems can be accessed by the AR&C systems within the avionics module (similar to the method used by the EVA Retriever). An MMU pilot

would have the capability of transitioning control of the MMU between automated and manned operations during the on-orbit demonstration. In this manner, the MMU pilot can monitor the experiment and take over manual control of the MMU as the backup return and safety system in the event of an AR&C system malfunction. Various docking/capture targets could be mounted on the orbiter RMS for emulation of target spacecraft dynamics in various lighting conditions. MMU control authority can be degraded by pulsing thrusters to simulate the Orbiter or Cargo Transfer Vehicle (CTV) so as to use similar gains in the system evaluation. The recharge capability of the MMU will make it possible for repeated experiments to be performed during a six (6) hour EVA.

The on-orbit demonstration can also be performed in an unmanned manner using only the MMU and avionics module. The EVA Retriever experiments conducted by JSC on the PABF during recent years have demonstrated the MMU's capability to be used as an autonomous conveyer for payloads. These experiments have developed the software necessary for the operation of the MMU through electrical interface between the payload and the MMU Control Electronics Assembly (CEA). The payload can be mechanically interfaced with the MMU through the existing Personal Life Support Systems (PLSS) latch and electrically interfaced through the Hand Controller connectors. The Control Arms can be removed to increase the payload capacity and expand the payload envelope. To simplify the experiment itself, the second MMU not fitted out for autonomous operation can be used as a retriever in the event of failure. A simple docking device on the payload and MMU would be sufficient for capture and return to the Shuttle as long as the experiment is within the MMU range capabilities (< 300 ft. from the Shuttle Orbiter).

Design, development, integration, test and training for such missions can be performed using existing MMU simulation facilities. The Space Operations Simulation (SOS) Laboratory at Martin Marietta Astronautics in Denver can model each element of the avionics package and provide the moving base for MMU flying tasks and algorithm development. Hardware testing and fit checks of experiments can be performed on the High Fidelity Mockup and Air Bearing Simulator (MMU - QTU) at JSC. Shuttle Cargo Bay operations such as installation on and interface with the MMU can be accomplished in the Water Emission Test Facility (WETF) also at JSC. Detail flight training and evaluation of the integrated system, the MMU and the avionics package, can be done in the SOS Laboratory.

Conclusion

The MMU is a proven performer that can be used as a tool for near term On-Orbit Automated Rendezvous and Capture experiments. The system has a track record from the satellite retrieval missions and EVA Retriever experiments for both manned and unmanned flight operations. Facilities exist, both at Martin Marietta and NASA, which are capable of evaluating designs, and providing operational training to Astronauts for either manned or unmanned flights.

Manned versus Unmanned Rendezvous and Capture

U.S. Automated Rendezvous and Capture Capabilities Review
Williamsburg, VA
November 19-21, 1991

Adam R. Brody
Sterling Software
NASA Ames Research Center
MS 262-2
Moffett Field, CA 94035-1000
415-604-5751
FAX 415-604-3323
brody@eos.arc.nasa.gov

Abstract

Rendezvous and capture (docking) operations may be performed either automatically or under manual control. In cases where humans are far from the mission site, or high-bandwidth communications lines are not in place, automation is the only option. Such might be the case with unmanned missions to the moon or Mars that involve orbital docking or cargo transfer. In crewed situations where sensors, computation capabilities, and other necessary instrumentation are unavailable, manual control is the only alternative. Power, mass, cost, or other restrictions may limit the availability of the machinery required for an automated rendezvous and capture. The only occasions for which there is a choice about whether to use automated or manual control are those where the vehicle(s) have both the crew and instrumentation necessary to perform the mission either way.

The following discussion will focus on the final approach or capture (docking) maneuver. The maneuvers required for long-range rendezvous operations are calculated by computers. It is almost irrelevant whether it is an astronaut, watching a count-down timer who pushes the button firing the thruster or whether the computer keeps track of the time and fires with the astronaut monitoring. The actual manual workload associated with a mission that may take as long as hours or days to perform is small. The workload per unit time increases tremendously during the final approach (docking) phase and this is where the issue of manual versus automatic is more important.

The decision over whether a mission will be under automatic or human control will not be made for technological reasons. The Soviets pioneered automatic docking in October 1967 when Kosmos (Cosmos) 186 docked with Kosmos 188 automatically. Clearly current American capabilities in this area, though unproven in space, should be at least as high as Soviet abilities of 24 years ago. However, all Gemini and Apollo docking operations, and all satellite rendezvous and capture maneuvers performed by the space shuttle were performed under manual control. The rationale for using manual control as opposed to automatic control have their origins in the Right Stuff, lack of automatic capability, and human factors. (Incidentally, the common perception that the Soviets use automatic control for all of their docking operations is not correct. When cosmonauts are in the approaching vehicle, they take over from the automatic system when the range is a few hundred meters. The Progress resupply vehicles dock automatically, but the crew are very carefully monitoring the situation and are ready to take control if necessary. (Newkirk, 1990))

NASA commanders and pilots have historically (and most likely will continue to) come from a military pilot background. They have the Right Stuff and they want their hands on the "wheel." They do not want to sit idly by and watch the automatic system perform the maneuver

58-13

NBS. ONLY

N 93-22234

146 117

P-3

for them. This philosophy is not restricted to future docking operations. The space shuttle and many commercial jet airliners have an automatic landing capability. (Landing an aircraft is roughly analogous to a spacecraft docking operation as they both involve terminal guidance.) In the space shuttle's case, this automatic landing capability has never been used. Commercial airline pilots typically take out the automatic system only periodically, rather than routinely, to make sure it still works. While one might argue that a docking is more deterministic (there are no crosswinds, rain, snow, or other obstacles) and therefore easier to be automated, the fact remains that in more mundane environments than space, human nature prevents the use of automatic pilot systems.

Automatic docking with space station *Freedom* is almost a non issue. Docking could probably be performed with passive reflectors on the station, as Marshall Space Flight Center researchers have been simulating on the air-bearing floor for many years. However, with a target as valuable as the manned station, an active targeting system would most likely be an imperative. Unfortunately, the laser rangefinder for docking was removed from the station design early on its design. Without this device, or something similar, automatic docking will not be performed.

In addition to the Right Stuff justifications, and the lack of essential targeting hardware, there are human performance reasons for using manual control when possible. Humans are good controllers but poor monitors. There is a very real fear, particularly in commercial aviation, of automating pilots out of the loop. The existence of accidents in nuclear power facilities and subway systems serves to support this contention. (Wiener, 1988)

The following extended quotation relating to manual control was taken from (Brody, May 1991, pp. 4-5).

The importance of manual control aspects of spaceflight operations, such as rendezvous and docking, was recognized early in the United States space program. After only three manned flights in the Mercury Program, the Technical Director of the Behavioral Sciences Laboratory, Aerospace Medical Research Laboratories, Wright-Patterson AFB concluded that "men can contribute greatly to the successful accomplishment of many types of space missions. . . . the Mercury astronauts were able to manually compensate for equipment malfunctions and thereby complete missions which otherwise would have failed or terminated prematurely" (Grether, 1963, p. 79). As Gemini XII and Apollo XI astronaut Buzz Aldrin explains, "Manned orbital rendezvous was a vital field, because any way you cut it, if we were going to assemble large interplanetary spacecraft, we'd have to master the techniques of space rendezvous—bringing two or more separately launched spacecraft together in orbit. With computers we could reduce the blizzard of spherical geometry and calculus equations down to automated rendezvous procedures. But I'd seen enough autopilots malfunction during my flying career to realize that the spacecraft NASA planned to use for Earth orbital lunar spaceflight would need some kind of manual backup" (Aldrin & McConnell, 1989, p. 67). The Soviets also value the flexibility that manual control allows in "the capabilities of man to see three dimensions and to evaluate the situation better than a machine for flight conditions that have not been provided for by the program" (Meshcheryakov & Minaev, p. 804). Gemini X and Apollo XI astronaut Michael Collins advocates manual control as follows: "was this not a noble cause, to build an autonomous capability, to allow a manned spacecraft to roam free of ground control, to compute its own maneuvers? Was not the very name of the game, in manned space flight, to put the pilots in control" (Collins, 1974, p. 169)?

Further justification for manual control may be found in the airline industry where "pilots still manually fly even the most highly automated aircraft, if only to maintain their flying skills in the case that they are called on if the automatics fail" (Nagel, 1988, pp. 293-4). Also, the adaptive capability that humans bring to control tasks adds further weight to the decision to use manual control instead of automation.

While automation is and will continue to be an important aspect of manned space flight,

It is unlikely that the pilot will be eliminated, any more than will the operator of a nuclear power plant. Our society believes that humans should have ultimate responsibility for control of complex systems even if inserting the human degrades overall system performance most of the time. The human is still the ultimate back-up system. While machines that are overloaded fail abruptly, people degrade gracefully under excessive levels of workload. Thus it seems prudent to include human operators, even if only as the sub-system of last resort that can "pull the plug." Furthermore, there are also strong political forces to keep humans employed. (Kantowitz & Casper, 1988, p. 183)

A number of studies have been performed recently to quantify the human performance envelope involved with piloting a spacecraft docking maneuver. (Brody, 1987, 1989ab, 1990ab, 1991; Brody and Ellis, 1990, 1991ab, in press) Many factors affect the ability of a crewperson to perform such a maneuver including: thruster magnitude, braking gates, control mode, impact velocity, docking port location. With a better understanding of how these factors affect performance, mission and hardware designers will be able to take action to increase safety, performance, reliability, and productivity while reducing cost. Benefits from this work, such as reduced operational costs, will greatly enhance the United States space program.

References

- Aldrin, B. & M. McConnell. (1989). Men From Earth. New York, Bantam Books.
- Brody, A. R. (1987). Spacecraft Flight Simulation: A Human Factors Investigation into the Man-Machine Interface Between an Astronaut and a Spacecraft Performing Docking Maneuvers and Other Proximity Operations. Unpublished Master's thesis, Massachusetts Institute of Technology, Cambridge, MA. see also NASA CR-177502, Sept. 1988.
- Brody, A. R. (1989a). The Effect of Initial Velocity on Manually Controlled Remote Docking of an Orbital Maneuvering Vehicle to a Space Station. American Institute of Aeronautics and Astronautics, Paper 89-0400, Washington, DC:
- Brody, A. R. (1989b). Remote Operation of an Orbital Maneuvering Vehicle in Simulated Docking Maneuvers. Third Annual Workshop on Space Operations Applications and Research (SOAR '89). Washington, DC: National Aeronautics and Space Administration, NASA CP-3059.
- Brody, A. R. (1990a). "Evaluation of the "0.1% rule" for Docking Maneuvers." Journal of Spacecraft and Rockets. 27(1): pp. 7-8.
- Brody, A. R. (1990b). Recovery from an Anomalous Thruster Input During a Simulated Docking Maneuver. Fourth Annual Workshop on Space Operations Applications and Research (SOAR '90). Washington, DC: National Aeronautics and Space Administration, NASA CP-3103.
- Brody, A. R. (1991). Quantitative and Qualitative Comparison Between Acceleration Control and Pulse Control in Spacecraft Docking. Unpublished Master's thesis, San Jose State University, San Jose, CA.
- Brody, A. R. & S. R. Ellis. (1990). "Effect of an Anomalous Thruster Input During a Simulated Docking Maneuver." Journal of Spacecraft and Rockets. 27(6): pp. 630-633.
- Brody, A. R. & S. R. Ellis. (1991a). A Comparison of Acceleration Control and Pulse Control in Simulated Spacecraft Docking Maneuvers. Washington, DC: American Institute of Aeronautics and Astronautics, 91-0787.
- Brody, A. R. & S. R. Ellis. (1991b). Logistics and Operations Implications of Manual Control of Spacecraft. Washington, DC: American Institute of Aeronautics and Astronautics, 91-4094.
- Brody, A. R. & S. R. Ellis. (in press). "A Comparison of Acceleration Control and Pulse Control in Simulated Spacecraft Docking Maneuvers." Journal of Spacecraft and Rockets.
- Collins, M. (1974). Carving the Fire An Astronaut's Journeys. New York: Bantam Books.
- Grether, W. F. (1963). Human Performance Capabilities for Military Operations in Space. In Lectures in Aerospace Medicine. Brooks Air Force Base, TX: USAF School of Aerospace Medicine, Aerospace Medical Division.
- Kantowitz, B. H. & P. A. Casper. (1988). Human Workload in Aviation. Human Factors in Aviation. San Diego: Academic Press, Inc.
- Meshcheryakov, I. P. & Minaev, S. A. (1976). "Construction and Investigation of an Information Model of the Process of Approach of Piloted Spacecraft." 15: 804-807.
- Nagel, D. C. (1988). Human Error in Aviation Operations. Human Factors in Aviation. San Diego: Academic Press, Inc.
- Wiener, E. L. (1988). Cockpit Automation. Human Factors in Aviation. San Diego: Academic Press, Inc.

1945

1946

1947

1948

1949

1950

1951

1952

1953

1954

1955

1956

1957

1958

1959

1960

1961

1962

AUTONOMOUS RENDEZVOUS AND CAPTURE DEVELOPMENT INFRASTRUCTURE

Thomas C Bryan Fred Roe Cindy Coker Pam Nelson B. Johnson
(205) 544-3550 544-351 544-3541 544-3645 544-3518

NASA- Marshall Space Flight Center [FAX (205) 544-5864]

In the development of the technology for Autonomous Rendezvous and Docking, key infrastructure capabilities must be used for effective and economical development. This involves facility capabilities, both equipment and personnel, to devise, develop, qualify, and integrate ARD elements and subsystems into flight programs. One effective way of reducing technical risks in developing ARD technology is the use of the ultimate test facility, using a Shuttle-based reusable free-flying testbed to perform a Technology Demonstration Test Flight which can be structured to include a variety of additional sensors, control schemes, and operational approaches. This conceptual testbed and flight demonstration will be used to illustrate how technologies and facilities at MSFC can be used to develop and prove an ARD system.

Conceptual Demonstration Testbed

Structured to leverage on flight experiment experience and qualified equipment, the concept uses the existing Multi Purpose Experiment Support Structure (MPES) or Shuttle Pallet Satellite (SPAS), as a Shuttle deployable /retrievable target vehicle (with a cold-gas Three-axis stabilization system) with accommodation for assorted sensors and subsystem tests. A small automated chase vehicle can be adapted from a Lightsat to carry ARD equipment and will fly various 6 Degree-of-Freedom separations and approaches. GPS can be used for rendezvous, MSFC's Video Guidance Sensor for final approach, the OMV-derived Three Point Docking Mechanism for docking, and the Automated Fluid Interface system for umbilical connection. The chase vehicle is docked and locked onto the pallet after testing and integration, allowing the shuttle crew and the ground processing to handle the experiment as a single integrated payload. Using this demonstration concept as a strawman program, the potential utilization of various facility capabilities at MSFC will be discussed.

Flight Robotics Laboratory

The Flight Robotics Laboratory, also known as the "Flat Floor", will continue two decades of developing and applying ARD and servicing technology to various programs. The Lab has

a 28m x 13m precision epoxy flat floor which can support various simulators and low-friction air-bearing platforms to support actual flight hardware with cold-gas thrusters.

The Spacecraft Air-bearing Simulator with self-contained power, propulsion, communications, guidance, navigation, and control, will be used for docking Mechanism and video guidance development, calibration, and demonstration. Designed to overcome limitations of air-bearing simulators, the Dynamic Overhead Telerobotic Simulator can dynamically position up to 500Kg of mockups, sensors, or flight hardware through the 50m x 15m x 9m facility with 1cm accuracy at computer-controlled velocities for realtime simulation of orbital dynamics, lighting, and body dynamics. Not only can the DOTS support mechanism and sensor development, orbital operations can be modelled dynamically and flight hardware and software can be evaluated and verified. Final system checkout can be done with both testbed vehicles active by simply floating the actual experiment carrier-target on the flat floor and "flying" the integrated small chase vehicle through simulated approach, station-keeping, docking, and separation operations, mounted on the DOTS and driven by a math model responding to actual vehicle generated thruster commands.

Space Operations / Mechanisms Test Bed

The Space Operations and Mechanism Test Bed, also known as the "6DOF", plays a critical role in developing and validating docking/berthing/grappling mechanisms and operations from Skylab to Shuttle and Space Station. The 6DOF simulation provides high fidelity simulation of the contact and body dynamics for full-scale docking/berthing mechanism evaluations. The six degree-of-freedom (6DOF) platform which carries the mechanism under evaluation is moved by hydraulics controlled by high-speed computer math models with extremely accurate force-moment sensor feedback. Additionally, video and graphic simulations support manned system operations such as crew monitoring and operations initiation as well as advanced control system analysis.

Optical Instrumentation Facilities

MSFC has a strong optical infrastructure, with many unique facilities including stray light vacuum tunnel, coherent lidar facility, video/camera laboratory and related development capabilities used to support various programs from Apollo, Skylab, HEAO era to the Great Observatories Program, Laser Atmospheric Wind Sounder, Space Station Freedom assembly, and Launch Systems preparation. These capabilities will be used for video guidance sensor testing and rendezvous laser radar development and evaluation.

RF System Test Facilities

MSFC's RF capabilities, including a 120/800m antenna range, 108000 cu.ft. microwave anechoic chamber, and various bench laboratories, will be used to support RF radar & tracking analysis-design-development-test-evaluation as well as command/telemetry system design-development-test-sustaining engineering.

Environmental Testing

The environmental testing using various thermal-vacuum chambers and structural test stands will support system analysis with ARD component qualification, target & chase vehicle testing, structural modal survey, component vibration evaluation, and integral demo vehicle modal-acoustic-vibration testing. Contingency EVA provisions and procedures will be validated and crew training performed in the Neutral Buoyancy Simulator.

These MSFC facilities will utilize their civil servant staff and experts to support the ARD development and check-out activities. Additional support can be obtained from the Army Redstone Arsenal to perform long range airborne rendezvous and tracking evaluation and integrated system tests utilizing local helicopter crews, missile test ranges, and restricted airspace & airstrip.

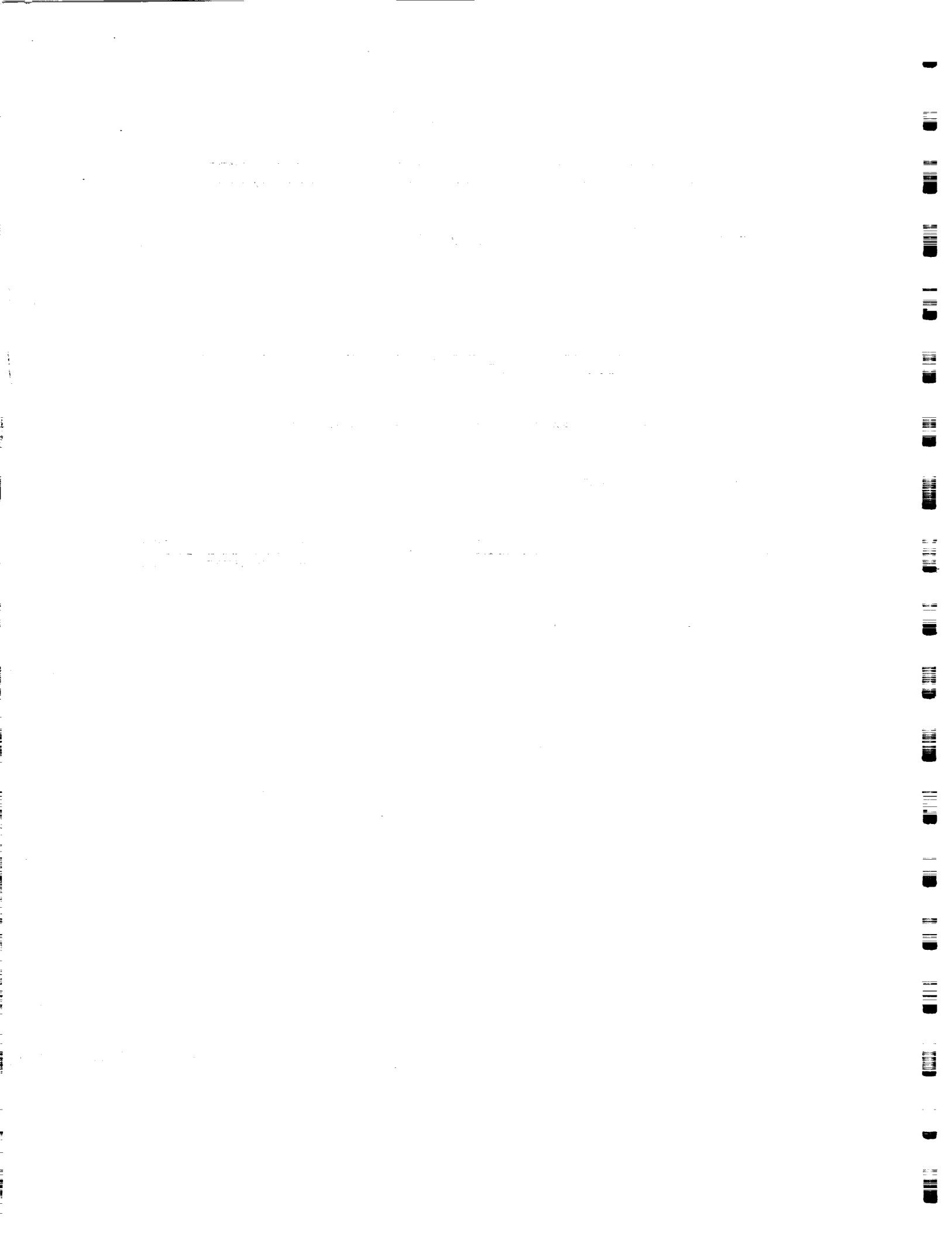

NATIONAL LAUNCH SYSTEM OVERVIEW
WITH
FOCUS ON CARGO TRANSFER VEHICLE

S10-15
ABS. ONLY
146721
P-2

N 93 - 22236

Harry Buchanan,
Marshall Space Flight Center

As a result of the Augustine Committee's recommendation to the National Space Council, the NASA and the DOD have embarked on a joint program to provide the nation with a new capability for transporting payloads into space. The National Launch System (NLS) consists of a family of modular launch vehicles, combining elements of current launchers (Titan and Shuttle) with newly developed components. This family consists of 1) NLS-1 (a vehicle capable of delivering 80k to SSF), 2) NLS-2 (a vehicle capable of delivering 50k to LEO) and 3) NLS-3 (a vehicle capable of delivering 20k to LEO). Management of the program is shared between the two agencies with a Joint Program Office carrying out the Level II management and integration function while both the NASA and Air Force field organizations are charged with the various development and operational responsibilities.

For cargo delivery to SSF, the CTV is an integral and necessary part of the NLS. It performs two distinct functions: 1) first it provides the necessary delta vee to circularize the payload in a phasing orbit which will cause it to rendezvous with the SSF; 2) once this rendezvous has taken place, the CTV is responsible for bringing the cargo close to the station and holding it for capture by the SSF mobile arm. In addition the CTV will be responsible for disposal of the unloaded cargo carrier and any SSF trash that has been placed on board.

AS many of you know the CTV program has had two NASA precursors, the Teleoperator Retrieval System (TRS), which was designed to reboost the Skylab space station and the more recent Orbital Maneuvering Vehicle (OMV). Both of these vehicles were designed to be remotely piloted using a video image transmitted from the vehicle to a pilot console. The pilot then used hand controllers to fly the vehicle for docking or other proximity maneuvers. While both of these programs were cancelled, this basic scheme was found to be generally workable although it was complex in implementation.

Because the CTV is an unmanned vehicle carrying out repetitive maneuvers with SSF, it can benefit substantially from automated rendezvous and capture technology such as that being discussed at this conference. A remotely piloted system, in which the pilot constitutes an integral part of the flight control system, results in complex interactions between questions involving communication, on board redundancy, control console/pilot redundancy, etc. In an automated design systems can be simpler to design, failure modes are easier to define and plan for and the verification of the flight control system is a more manageable job. From a SSF point of view the amount of CTV related gear required on the SSF can generally be reduced since most of the system can be built into the CTV. This of course translates into a simpler interface that is easier to manage.

**AUTOMATED TECHNOLOGIES NEEDED TO PREVENT RADIOACTIVE
MATERIALS FROM REENTERING THE ATMOSPHERE**

N 93522237

David Buden
Idaho National Engineering Laboratory
P.O. Box 1625
Idaho Falls, ID 83415-1550
(208) 525-5626
Fax (208) 525-5616

IBS ONLY
146722
P- 6

Dr. Joseph A. Angelo, Jr.
Science Applications International Corporation
700 Babcock Street-South (Suite 300)
Melbourne, FL 32901
(407) 676-3102
Fax (407) 676-1628

Project SIREN (Search, Intercept, Retrieve, Expulsion Nuclear) has been created to identify and evaluate the technologies and operational strategies needed to rendezvous with and capture aerospace radioactive materials (e.g., a distressed or spent space reactor core) before such materials can reenter the terrestrial atmosphere and then to safely move these captured materials to an acceptable space destination for proper disposal. A major component of the current Project SIREN effort is the development of an interactive technology model (including a computerized data base) that explores in building block fashion the interaction of the technologies and procedures needed to successfully accomplish a SIREN mission. This SIREN model will include appropriate national and international technology elements-both contemporary and projected into the next century. To permit maximum flexibility and use, the SIREN technology data base is being programmed for use on 386-class PCs.

As suggested in recent national studies, space nuclear reactors can provide unique power and propulsion options for advanced space applications such as lunar bases and Mars expeditions and surface bases, interplanetary transportation systems, deep Solar System exploration missions, and large-scale Earth orbiting civilian platforms and defense missions. When used at sufficiently high orbits, the radioactive fission products created in the operation of such space nuclear reactors can decay by natural processes to insignificant, harmless levels prior to any atmospheric reentry of the aerospace system centuries or millennia later. However, there are other important space missions that will require the start of the reactor operations while the aerospace system is still at orbits lower than those considered sufficiently high to accommodate fission product decay. In the past, a chemical booster system has been incorporated into these lower altitude satellites. Unfortunately, as shown by operational experience (i.e., COSMOS 954 and 1402 see Fig.1) these booster mechanisms can fail. Furthermore, it may not always be desirable to incur the mass-penalty associated with an on-board booster system as may be the case on the vehicle used for a manned Mars expedition. Project SIREN is, subsequently, being investigated as an external,

independent means to capture and expel spent or distressed aerospace nuclear sources under these circumstances and similar situations that could arise with the expanded use of nuclear power systems in space in the next century.

Previous SIREN studies have identified (on a first order basis) credible technical solutions for the acquisition and disposal portions of a SIREN mission. The major technical elements for a successful SIREN mission include: ground and space-based tracking; launch vehicles of needed payload capacity; telerobotics systems; sensors; capture technologies; and space transport and disposal.

Although no dedicated "SIREN-type" capability is in place today to prevent the errant reentry of a distressed space nuclear power source, many components necessary for a successful SIREN mission exist or are now planned as part of the emerging national and international aerospace technology infrastructure. Functional and operational requirements of many of the technical components of a SIREN capability are evolving to consonance with the 21st Century space infrastructure needed to accomplish the advanced civilian and defense missions. However, SIREN will also impose specialized requirements including the use of dextrous aerospace systems capable of properly functioning in intense radiation and thermal environments. Another interesting SIREN technology requirement will be the ability of SIREN hardware to function universally - that is both cooperatively and effectively on space nuclear systems of all nations.

It is also anticipated that the advanced automated rendezvous and capture technologies necessary to perform SIREN will support many other important space missions in the 21st century, such as on-orbit spacecraft maintenance and servicing and space debris remediation activities.

The SIREN data base now being constructed in building block fashion (for example, see Figs.2 to 4) will cover all the principal technology elements needed to successfully accomplish a SIREN mission. Inputs to these building block categories should also provide a valuable stimulus to those now investigating automated rendezvous and capture technology and operational requirements.

This work is sponsored by the Strategic Defense Initiative Organization. Current funding level is approximately one million dollars over a two year period.

Re-Entries of Soviet Space Nuclear Power Sources

<u>Name</u>	<u>Launch Date</u>	<u>Reentry Date</u>	<u>Type of Power Source</u>	<u>Comments</u>
.	25 Jan 1969	25 Jan 1969	Reactor	Possible launch failure of RORSAT
Cosmos 300	23 Sep 1969	27 Sep 1969	Radioisotope	One or both of these payloads may have been a Lunokhod and carrying a 210Po heat source. Upper stage malfunction prevented payloads from leaving Earth orbit.
Cosmos 305	22 Oct 1969	24 Oct 1969		Probable launch failure of RORSAT.
.	25 Apr 1973	25 Apr 1973	Reactor	Payload malfunction caused reentry near Great Slave Lake in Canada.
Cosmos 954	18 Sep 1977	24 Jan 1978	Reactor	Payload failed to boost to storage orbit on 28 Dec 1982. Spacecraft structure reentered at 25°S, 84°E. Fuel core reentered at 19°S, 22°W.
Cosmos 1402	30 Aug 1982	23 Jan 1983 (spacecraft) 7 Feb 1983 (reactor core)	Reactor	

Bennett 7th SNPS Proceedings, 1990

TRACKING SENSOR

System: SENSOR Type	Class: [Radar, Imaging]	Type: [Laser, IR]
Operational Availability: [Day, Night, 24 Hours]		
Field Of View		
Minimum: [Deg]	Maximum: [Deg]	
Angular Resolution		
Minimum: [Deg]	Maximum: [Deg]	
Spectral Response		
Minimum: [mm, μ m, nm]	Maximum: [mm, μ m, nm]	
Detection Threshold: [Object Size, Radiance, Maximum Range]		
Data Rate: [Hz]		
Data Output: [Range, Radiance, Image, Temperature, Size, Orientation, Target Dynamics (Spin, Tumble, Vibration, Wobble)]		

TRACKING FACILITY

System: Tracking Facility		Class: [Ground, Space]	Type: [AMOS, Firepond]
Ground Based		Space Based	
Latitude:	Longitude:	Altitude: [m]	Orbit Type:
		Altitude: [km]	Inclination:
Affiliation: [AF, ARMY, etc.]			
Key Personnel:			
POC			
Address			
Phone, etc.			
Availability: [Dates, Times,...]			
Blackout Periods: [Dates, Times,...]			
Tracking Assets: [ASSET_Type, ASSET_Type,...]			

CAPTURE VEHICLE DATA SHEET

CAPTURE VEHICLE - ID: OMV		Class: Capture Vehicle	Type: OMV
Thrust:	Mass:		Volur
Pre-deployment Dimension-X _i :	Pre-deployment Dimension-X _j :		Pre-deployment Dimension-X _j :
Post-deployment Dimension-X _i :	Post-deployment Dimension-X _j :		Post-deployment Dimension-X _j :
Moment of Inertia-X _i :	Moment of Inertia-X _j :		Moment of Inertia-X _j :
Isp Capabilities/Fuel Type:	Rad Hard Limits:		Temperature Limits:
Sensor Types:	Shutters:		Power:
Deployment Vehicle:			Fuel Capacity:
Communication:	Maneuver Capabilities:		G-Load Limit:
Latch-up Limits:	Survivability Limits:		Operational Orbits:
Alt-change Capabilities: (If this is a transfer Vehicle)	Inclination Change: (If this is a transfer Vehicle)		Payload:
Grapping Device Description:			

CAPTURE VEHICLE CAPABILITIES			
Mass:	Thrust		Volume:
Dimension-X _i :	Dimension-X _j :		Dimension-X _j :
Time Required for Latch-up:	Fine Tuning for Latch-up:		Disposable:
Catcher System Description:			

572-18
ABS ONLY
746723
P- 2

N 93 - 22238

Autonomous Prealignment Of A Docking Mechanism

Presenters: Monty B. Carroll, John A. Thompson
Lockheed Engineering and Sciences Company
2400 NASA Road One
Houston, Texas 77058
(713) 483-8452

Abstract:

Proposed future space exploration, such as lunar and martian expeditions, will require autonomous docking of space vehicles. One proposed candidate method of autonomous docking utilizes a actively controlled parallel manipulator. Operation of the proposed docking manipulator can be segmented into four (4) successive events: Prealignment, Capture/Latching, Attenuation, and Structural Rigidization. This paper discusses the development and testing of a digitally controlled, six-degree-of-freedom (6-DOF), parallel manipulator for the prealignment segment of a docking spacecraft.

The manipulator, generically called a Stewart Platform, incorporates eight (8) electro-mechanical linear actuators operating in tandem to maneuver a mechanical docking interface in 3-dimensional space. The system is controlled by a central master controller overseeing eight digital servo controllers, one dedicated to the positioning of each actuator. A machine vision system is used to provide real-time position and orientation commands to the master controller. An optical target on a passive docking interface is sensed by the vision system via a CCD camera attached to the Stewart Platform. The vision system tracks the relative position and orientation between the target and the CCD camera providing 3-dimensional target position and orientation information to the master controller.

The master controller computes the desired Stewart platform position and orientation minimizing the misalignment between the passive and the active, i.e., Stewart platform, docking interfaces. It then converts the desired platform position and orientation into position commands for each of the eight linear actuators controlled by individual low level digital servo control circuit boards.

The system has been implemented on two prototypes. One prototype is a small-scale version used to develop the vision, control, and kinematic software, as well as low level servo control circuit boards. On this system a robotic arm is used to maneuver the passive

interface while the docking manipulator responds to its movements. The second prototype is used as a full-scale demonstration system. A docking facility located within the Structures and Mechanics Division at NASA, Johnson Space Center provides motion simulation of the passive interface for this prototype.

Several tests were performed on the demonstration system. The passive docking interface was cyclically rotated and translated to assess the tracking capability of the docking system. Tests designed to simulate typical vehicle approach/closing conditions were also conducted.

Results from the testing were favorable. System resolution and response were well within acceptable ranges. Key to successful system operation was the calibration of the vision system. Vision system difficulties were experienced with regard to lighting. Although calibration corrected for most of these problems, the robustness of the vision algorithm was of concern. Hardware performance also lacked the desired response. However, this problem was beyond our control since the Stewart platform used in the demonstration prototype was unalterable, and had been developed for a previous unrelated program.

Several worthwhile observations can be made about the design and development process of this project. During the development of the system, cycle update time, which includes processing video signals, computing docking kinematics, error checking, communications, and servo control, was dramatically reduced. The rapid loop rate achieved resulted from algorithm optimization (to be presented in a complete paper), and provided good system response and stability.

Additional conclusions can be drawn from more of a management philosophical viewpoint. Throughout the project efforts were made to utilize existing and/or off-the-shelf hardware. As such, minimal development time and costs were realized. Concurrent engineering techniques were also employed, further reducing development time. Finally, the small-scale prototype built to test software and control system proved to be invaluable as a cost saver.

Future work is to include the study of the remaining three phases of docking, i.e., capture/latching, attenuation, and structural rigidization. In addition, alternate vision algorithms which are less sensitive to lighting variation are to be investigated. A change in the control architecture is being initiated also.

513-13
#1133 ONLY
N93-22239
14624

U. S. AUTOMATED RENDEZVOUS AND CAPTURE CAPABILITIES REVIEW

REMOTE UMBILICAL SYSTEM ABSTRACT

P. 2

DATE: September 27, 1991

Author: Eduardo Lopez del Castillo Phone: (407) 867-4156
NASA , Kennedy Space Center Fax: (407) 867-2217
DM-MED-12
Kennedy Space Center, FL 32899

Technical details to be discussed:

This document will describe the technology developed at Kennedy Space Center (KSC) to demonstrate automatic tracking, docking and mating of umbilical systems. Specifically the use of a real time six degree of freedom (6DOF) target tracking vision system, (developed by Adaptive Automation, Inc. under contract to KSC), will be discussed in detail. The paper will also describe the use of mechanical compliance in the docking, mating and tracking - after- mating operations.

The vision system computes six coordinates that define the position and orientation of a three dimensional target using data from a single CCD camera. The camera is mounted on a 6DOF robot arm. After target coordinates are computed, they are transmitted to a supervisory computer which controls the robot motion in real time. Details of the image processing algorithms, image processing hardware, and target configuration used in the vision system are discussed in the paper.

The motion of the space vehicle relative to the service structure after mating led us to the development of a compliant system that allows enough displacement of the target relative to the camera so that tracking after mating may continue. This reduces internal stresses between flight and ground hardware.

Origins and Evolution of KSC tracking, mating and docking capabilities:

Umbilical systems are used in the space industry to supply fuel, power and life support systems to space vehicles during ground servicing operations. They save space vehicles that use liquid propellants in the event of an abort. In 1983 KSC began to investigate the possibility of automating umbilical mating operations mainly because it is desirable to disconnect prior to launch to insure there will be no disconnect problems. However in the case of an abort it is necessary to immediately reconnect to save the vehicle by downloading the propellants. Other disadvantages of current umbilicals are the dangerous and time consuming nature of the operation. Existing dangers include exposure of personnel to hazardous environment and the use of pyrotechnics to separate the T-0 umbilicals from the vehicle during lift-off. The goal was to develop an automatic system to successfully mate ground and flight side umbilical plates. Some of the constraints were:

1. Space vehicles on launch pads move relative to service structure due to wind, solar and thrust factors.
2. Cleaning and verification of fluid lines must be automated.
3. Mating is required in all weather and light conditions.

From 1983 to 1985, KSC detailed the requirements of a vision system and a 6DOF robot working together to follow a target moving in two dimensional space. ASEA Robotics and Adaptive Automation worked together to deliver the system. Testing revealed that much mechanical compliance was necessary with the system for the mating operation to work. Between 1985 and 1987 KSC decided to develop a 6DOF vision/force tracking capability to minimize mechanical compliance requirements. Adaptive Automation developed a 6DOF vision tracking system which is not manipulator dependent. This means that the algorithms can be used by robots other than the ASEA IRB-90 for which it was developed.

Today KSC has captured the technology that allows us to track, dock and mate a 200# ground umbilical plate to a flight plate moving at 3 in/sec. This was done combining the 6DOF vision system with mechanical compliance.

Level of maturity:

The 6DOF vision tracking technology is operational and a video tape with a demo is available for review.

System testing:

Testing has been done to quantify the system performance using an ASEA IRB-90 robot and a 200# payload on the arm. Results of tracking errors vs tracking speeds will be presented. Testing has also been conducted to quantify speed of data transfer between the vision system, the supervisory computer, and the robot controller. Results will also be discussed in the paper.

Fund sources:

The development of this technology was financed by the following groups: ETB, Code R, Advance Development and Shuttle production.

Current Funding Estimates:

Implementation of this technology for the Space Transportation System is not financially attractive. Therefore KSC has decided to stop further work on this project until an economically feasible application emerges. This could be the automation of umbilical systems for future space vehicles or the automation of tracking, docking, and mating operations required in space. Current funding levels will allow some further testing to be conducted to draw important conclusions which could be used at a later time.

**Automated Target Recognition and Tracking Using
an Optical Pattern Recognition Neural Network**

Tien-Hsin Chao

Jet Propulsion Laboratory
California Institute of Technology
Pasadena, CA 91109
Phone (818) 354-8614 Fax (818) 393-4820

514-74
HBS. ONLY
146725
N 93P-22240

Optical Automatic Target Recognition and Tracking System

The on-going development of an automatic target recognition and tracking system at the Jet Propulsion Laboratory is presented. This system is an optical pattern recognition neural network (OPRNN) that is an integration of an innovative optical parallel processor and a feature extraction based neural net training algorithm. The parallel optical processor provides high speed and vast parallelism as well as full shift invariance. The neural network algorithm enables simultaneous discrimination of multiple noisy targets in spite of their scales, rotations, perspectives and various deformations. This fully developed OPRNN system can be effectively utilized for the automated spacecraft recognition and tracking that will lead to success in the Automated Rendezvous and Capture (AR&C) of the unmanned Cargo Transfer Vehicle (CTV).

One of the most powerful optical parallel processors for automatic target recognition is the multichannel correlator. With the inherent advantages of parallel processing capability and shift invariance, multiple objects can be simultaneously recognized and tracked using this multichannel correlator. This target tracking capability can be greatly enhanced by utilizing an powerful feature extraction based neural network training algorithm such as the neocognitron. The OPRNN, currently under investigation at JPL, is constructed with an optical multichannel correlator where holographic filters have been prepared using the neocognitron training algorithm. The computation speed of the neocognitron-type OPRNN is up to 10^{14} analog connections/sec that enabling the OPRNN to outperform its state-of-the-art electronics counterpart by at least two orders of magnitude.

Origin and Evolution of the OPRNN System Capability

The Optical Processing Group of the Microelectronic Device Laboratory (MDL) at JPL started its development of a multichannel optical correlator a few years ago with the support of NASA RTOP funding. A 9 channel optical correlator was built and tested successfully for the simultaneous tracking of multiple objects. This multiple correlator was designed for potential NASA applications including orbiter and lander navigation and guidance of future planetary exploration missions as well as spacecraft rendezvous and docking.

Recently, the Strategic Defense Initiative Organization/Innovative Science and Technology Office (SDIO/IST) sponsored a program, through an agreement with NASA, to develop an OPRNN for the discrimination and tracking of SDI laser radar targets. Due to the complex nature of this problem, a neocognitron-type OPRNN was proposed for this application. The neocognitron uses a feature-extraction approach to discrimination. The evidence extracted by individual image features is fused in stages and, at each stage, allowance is given to scale and aspect angle variations. As a result, the neocognitron-type OPRNN is able to robustly recognize input images over a large range of scales and aspects.

We have devised an innovative system architecture that is able to implement the neocognitron-type OPRNN with shift invariance. A multichannel optical correlator is used as the basic building block of the OPRNN since shift invariance is an inherent advantage of the optical correlator.

In order to provide large system capacity and high speed thresholding detection for the neocognitron-type OPRNN, a binary optic grating and a thresholding detector array has been developed at the MDL. The binary optic grating is fabricated with an e-beam lithography system that is able to replicate an input image into a 9 x 9 uniform array such that 81 features of an input image can be processed simultaneously. With further development of this binary optics technology, up to 400 multichannel processing capability can be achieved. A 32 x 32 thresholding photodetector array chip has been designed, fabricated and tested. This photodetector array consists of 32 x 32 array cells each containing a photo-transistor for photon detection, comparator circuitry for thresholding control and digital circuitry for address reporting. This detector is able to process all the incoming signals in parallel by detecting and reporting, within two milliseconds. Further research is underway to design up to 128 x 128 photodetector array with submillisecond response time.

Level of Maturity

A prototype breadboard of a neocognitron-type OPRNN has been integrated at JPL. This system consists of a liquid crystal television spatial light modulator (LCTVSLM), a 9 x 9 binary optic grating, a thermoplastic holographic camera, and a 32 x 32 thresholding detector array. Simultaneous development of the binary optic grating and photodetector array is being continued to further enhance the system capability. Additional funding will be needed for conducting system packaging work to develop a full-functional compact system that is suitable for airborne and spaceborne operation.

Experimental Results

We have performed experimental investigations using a multilayer neocognitron-type OPRNN for discrimination of laser radar images of SDI objects such as re-entry vehicles and decoys. Experimental results demonstrate that, with the appropriate selection of the training features and our innovative multilayer processing scheme, successful recognition and tracking of multiple SDI objects with intra-class deformation tolerance and inter-class discrimination capability are achievable.

This experimental demonstration shows that the shift invariant OPRNN can be easily extended to applications useful to NASA missions involving spacecraft rendezvous and docking.

Source/sponsorship and Current Funding Estimates

The current level of support for the OPRNN system components development and breadboard demonstration is about \$300k/year funded by SDIO/IST and DARPA. Additional funding will be necessary to accelerate the technology development as well as the compact system integration such that it will be suitable for operation in a spaceborne environment.

513-17
N93-22241
NASA ONLY
1/26/72

Applicability of Relative GPS to Automated Rendezvous between
the Space Shuttle and Space Station

P-2

by Fred D. Clark and Ann Christofferson, both of Lockheed Engineering & Sciences Co. 2400 NASA Rd. 1, Houston, TX 77058
Phone- (713) 333-6284 & (713) 333-6377 respectively.
Fax- (713) 333-6908

Technical

The purpose of this study is to determine the adequacy of the Global Positioning System (GPS) in providing relative navigation for automated rendezvous and proximity operations. The study was performed using the Proximity Operations Simulator (POS), Lockheed's high-fidelity, 6 degree of freedom simulation of the space shuttle and space station.

This simulation includes identical models of GPS receivers for each vehicle. The navigation software in each vehicle includes identical Kalman filters. Each filter computes the absolute state of its vehicle, and the relative state vector is obtained by simply subtracting absolute states.

The GPS model includes errors in the ephemeris and clocks of the GPS satellites. Receiver clock errors and receiver noise are modeled, as well as ionospheric errors. Multipath and obscuration effects, however, are not modeled. The receivers can be modeled with either the precise positioning service (p-code), or with the standard positioning service (C/A code). Both filters include three state vector components for position, velocity, and unmodeled acceleration bias, one component for clock bias, and one component for clock frequency error.

The Shuttle Operational Rendezvous (SOR) profile was simulated with two exceptions. First, the orbiter was targeted to cross the +Rbar below the station and intercept the +Vbar 500 feet in front of the station, rather than targeted directly to the station. Second, when the angle between the line of sight to the station and the +Vbar reached 45 degrees, the orbiter was commanded by the guidance to remain on a 45-degree glideslope for the remainder of the trajectory.

In the simulations, five different dispersions in position and velocity were used to initialize the orbiter at a range of about 100 nmi. from the station. Simulations were run with both p-code and C/A code models and two different glideslope approach controller gains. Also, in one set of runs, estimated orbiter Reaction Control System (RCS) delta-v was used instead of Inertial Measurement Unit (IMU) data.

We found that relative GPS is adequate for controlling the trajectory of the shuttle along a 45-degree glideslope until quite close to the station. A sensor capable of estimating range, range rate, and bearing would be needed to complete the final phase of an automated rendezvous and capture.

Historical

The capability to use relative GPS for orbital relative navigation has been studied for several years. About a dozen GPS satellites are currently on orbit. The full constellation will be completed before first launch of the first space station elements. Lockheed's capability to simulate GPS navigation was first developed in 1984-5 and has evolved to a mature simulation.

Sponsorship

This work was supported by the Guidance and Prox Ops section of the Navigation & Guidance Systems branch of the Navigation, Control, & Aeronautics division at the Johnson Space Center.

Clark, Christofferson;

516-13

ABS. ONLY
N 93-22242
146/27

**Autonomous Rendezvous and Docking -
A Commercial Approach To On-Orbit Technology Validation**

P-1

P. Tchoryk, Jr., M.E. Dobbs, D.J. Conrad, D.J. Apley

Environmental Research Institute of Michigan (ERIM)
Space Automation & Robotics Center (SpARC)
P.O. Box 134001
Ann Arbor, Michigan 48113-4001
(313) 994-1200 x2738
(313) 665-6559 (Fax)

R.P. Whitten

NASA Headquarters, Office of Commercial Programs
Commercial Development Division (Code CC)
Washington D.C. 20546

ABSTRACT

The Space Automation and Robotics Center (SpARC), a NASA-sponsored Center for the Commercial Development of Space (CCDS), in conjunction with its corporate affiliates, is planning an on-orbit validation of autonomous rendezvous and docking (ARD) technology. The emphasis in this program is to utilize existing technology and commercially available components whenever possible. The primary sub-systems that will be validated by this demonstration include GPS receivers for navigation, a video-based sensor for proximity operations, a fluid connector mechanism to demonstrate fluid resupply capability, and a compliant, single-point docking mechanism.

The focus for this initial experiment will be expendable launch vehicle (ELV) based and will make use of two residual Commercial Experiment Transporter (COMET) service modules. The first COMET spacecraft will be launched in late 1992 and will serve as the target vehicle. The ARD demonstration will take place in late 1994, after the second COMET spacecraft has been launched. The service module from the second COMET will serve as the chase vehicle.

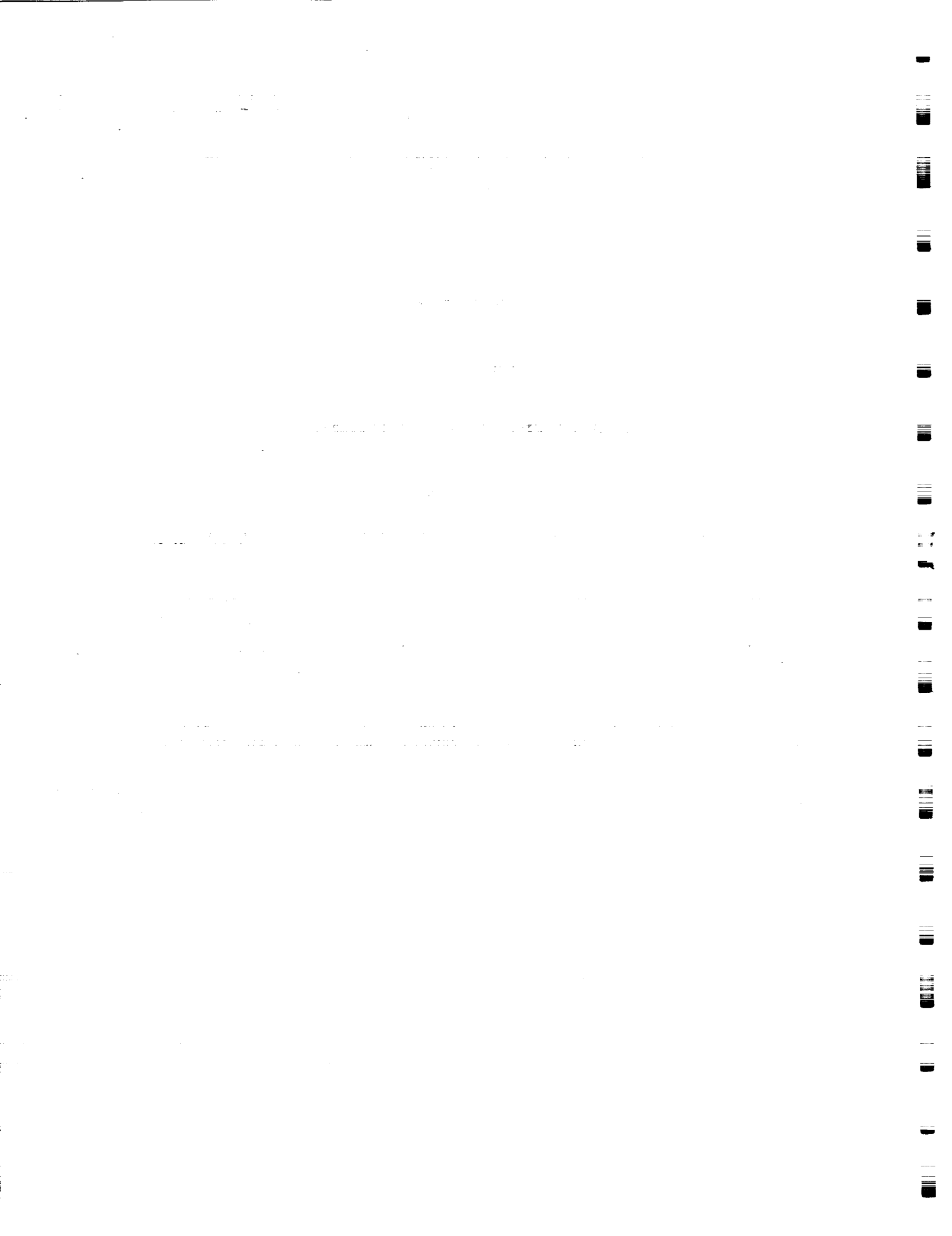

**REAL-TIME SIMULATIONS
FOR
AUTOMATED RENDEZVOUS AND CAPTURE**

**JOHN A. CUSEO (303-971-9302)
SPACE OPERATIONS SIMULATION LABORATORY
MARTIN MARIETTA ASTRONAUTICS GROUP**

17-13
ABS. ONLY
146728
N 93-22243

Although the individual technologies for automated rendezvous and capture (AR&C) exist, they have not yet been integrated to produce a working system in the United States. Thus, real-time integrated systems simulations are critical to the development and pre-flight demonstration of an AR&C capability. Real-time simulations require a level of development more typical of a flight system compared to purely analytical methods, thus providing confidence in derived design concepts. This presentation will describe Martin Marietta's Space Operations Simulation (SOS) Laboratory, a state-of-the-art real-time simulation facility for AR&C, along with an implementation for the Satellite Servicer System (SSS) Program.

The SOS Laboratory simulations use a combination of hardware and software to provide a high-fidelity testbed for development and analysis of AR&C systems including autonomous control algorithms, sensor subsystems, propulsion systems and docking mechanisms. The SOS Laboratory simulations also provide man-in-the-loop control (i.e., teleoperation) in addition to autonomous control for evaluation of supervised AR&C systems.

A major component of the simulation architecture is the moving base carriage (MBC). The MBC provides six degrees-of-freedom to simulate the rotational and translational state of the chase vehicle (i.e., CTV/STV), and its AR&C sensors, with respect to the target vehicle (i.e., SSF, STS, etc.). The MBC has a maneuvering volume of over 14,000 cubic feet to simulate approaches from 60 feet full scale. Simulation scales up to 100:1 are used to simulate approaches from 6000 feet. The target vehicles used in the simulations can be mounted on a single-axis or three-axis servo-driven gimbal system to increase the degrees-of-freedom available to facilitate simulation of maneuvers such as 360 degree fly-arounds or tumbling satellite retrieval. The MBC and target gimbals are controlled by an Encore 32/9750 simulation controller which also executes the software that models the spacecraft systems and orbital environment. This includes models of the chase and target vehicles GN&C system, propulsion subsystem, inertial measurement systems and mass properties. Other key components of the simulation architecture include the on-orbit and ground control supervisory control consoles. These consoles are integrated into the real-time simulation and provide all the functions required to teleoperate a free-flying spacecraft and/or supervise the operations of an autonomous system during rendezvous and capture.

The elements of the SOS Laboratory described above have been integrated to provide a real-time integrated systems end-to-end simulation for the Satellite Servicer System program. The simulation includes all elements of the SSS Flight Demonstration

program: autonomous rendezvous and capture, supervised autonomous orbital replacement unit (ORU) replacement, supervised autonomous fluid resupply and proximity operations. The end-to-end simulation of the flight demonstration involves deployment of the satellite servicer system and target vehicle from STS, separation and subsequent autonomous rendezvous and capture, supervised autonomous ORU replacement and fluid resupply, and ending with retrieval of the satellite servicer system and target vehicle by STS.

A six minute videotape titled "Satellite Servicer System End-to-End Simulation" will also be presented which highlights the SOS Laboratory's capabilities with respect to autonomous rendezvous and capture.

518-18
N 93 22244
146729
P. 3

Abstract submission for the AR&C conference at Williamsburg,
VA on Nov. 12-21, 1991.

CATEGORY 2: Software Systems: Guidance/Navigation and Control

Title: Autonomous Rendezvous and Capture System Design

By: Richard W. Dabney phone 205-544-1473; FTS 824-1473
MSFC/ED13 FAX 205-544-0236; FTS 824-0236

Marshall Space Flight Center has a long history of involvement in the design of Autonomous Rendezvous and Capture (AR&C) systems. The first extensive studies were begun in the late seventies, incrementally leading to the development of an assortment of Guidance, Navigation, and Control (GN&C) concepts and algorithms suitable for a variety of mission requirements and spacecraft capabilities, with a strong emphasis placed upon flexible system-level design. These efforts have led to the development of sophisticated algorithms for docking with tumbling targets, and simple but efficient algorithms for stabilised spacecraft; each has been tested and validated using dynamic system simulation, with hardware in the loop when practical. Recent investigations include the use of neural networks for video image interpretation, and fuzzy logic for control system implementation.

In the late seventies, there was a desire for an ability to dock with tumbling spacecraft using a small teleoperated vehicle which would be flown from the Shuttle aft flight deck. Its mission objectives included docking with and reboosting the Skylab space station, which had lost its attitude control system. Pilot-in-the-loop ground simulations indicated that this was a difficult task for a human operator because of the high angular rates present on the target vehicle. There was a clear need for an automatic system which could perform the necessary maneuvers with a greater degree of speed, precision, and flexibility. A survey (reference 1) was made to evaluate the state-of-the-art in sensor technology, and several design concepts were identified as promising. Video-based sensors were chosen for detailed study, because of the low cost and low development risk involved. The next step would be selection of a suitable docking target, along with appropriate image processing/interpretation and GN&C algorithms. A study was made of three candidate schemes (reference 2), resulting in the selection of a three-point target consisting of radio-activated strobe lights, viewed by a monochrome vidicon camera with synchronous scanning. A very robust control algorithm was used; it consisted of a standard phase-plane function driven by a goal-setting logic, which effectively determined the shape

of the approach trajectory by establishing a dynamic "aim point" on the target docking axis. A Kalman filter was used to smooth sensor noise and facilitate continued flight during brief data interruptions. A comprehensive series of dynamic simulations established the ability of the system to capture tumbling targets and identified weaknesses for which fixes were devised (reference 3). A series of hardware-in-the-loop runs defined the attainable sensor performance, and served as the basis for further software upgrades (references 4 and 5).

To avoid over-dependence upon a particular technology, a low-level parallel study of radio-frequency (RF) -based sensors was conducted. They offer the advantage of being totally immune to lighting problems, although typically more expensive and less accurate. A then-new device known as a "nonlinear reflector" was evaluated for docking purposes (reference 6); although a passive device, it returns an RF wave on a integer multiple of its original frequency. Three of these reflectors attached 120 degrees apart around the front of the target spacecraft allow measurement of all six degrees of relative freedom.

In 1987 a cooperative effort with Richard T. Howard of MSFC's Information and Electronic Systems lab led to the first known full-scale hardware-in-the-loop demonstration of AR&D with a totally passive target. The use of a passive target provides a capability of docking with a totally dead spacecraft, which is important for servicing missions, such as the Solar Max repair of the early 80's. A video-based technology was chosen because of the low cost and extensive experience accumulated during the decade. A passive target was devised consisting of a standard RMS (remote manipulator system) target with pieces of reflective tape attached to the center post and the ends of the baseplate. This target was later patented (no. 5,020,876), being the first known target suitable for piloted and automatic operation alike. Two video trackers were tested; a CCD-based unit with multiple-wavelength laser illuminators was developed to provide complete clutter rejection. A proportional-derivative control algorithm with rate limiting proved suitable for this application, which involved docking with stable targets from 100 feet or less. The complete system (reference 7) has been subjected to extensive testing and is now considered ready for flight demonstration.

Current efforts in AR&C software at MSFC are directed at the exploitation of new technology such as neural networks and fuzzy logic to improve the performance, flexibility, and reliability of AR&C systems. A neural network has already been developed to derive relative attitude and position data from the target video coordinates (ref. 8). The brute force approximation previously in use was neither as accurate or computationally efficient. It is possible in fact to replace all of the existing image pro-

cessing, GN&C, and thruster selection algorithms with neural networks, and achieve significant improvements in computational speed, mission flexibility and redundancy. The goal of these efforts is a hardware-in-the-loop demonstration or AR&C involving neural nets and fuzzy logic wherever beneficial, illustrating each of these features.

- REFERENCES:
1. "Study of Automated Rendezvous and Docking Technology", final report contract JPL-955363
 2. "Development of an Autonomous Video Rendezvous and Docking System", phase I final report contract number NAS8-34679, MCR-82-569
 3. "Automatic Rendezvous and Docking: A Parametric Study", NASA technical paper 2314
 4. "Development of an Autonomous Video Rendezvous and Docking System", phase II final report contract number NAS8-34679, MCR-83-584
 5. "Development of an Autonomous Video Rendezvous and Docking System", phase III final report contract number NAS8-34679, MCR-84-502
 6. "Polarised-Interferometer Feasibility Study", final report contract number NAS8-34960, July 1983
 7. "Development of a Video-Based Automatic Rendezvous and Docking System", by Richard Dabney and Richard T. Howard, SME Robotics and Space Conference, Jan. 1988.
 8. "Autonomous Rendezvous and Docking System Design and Simulations", by Richard W. Dabney, Autonomous Rendezvous and Docking Conference, J.S.C. 8/15/90

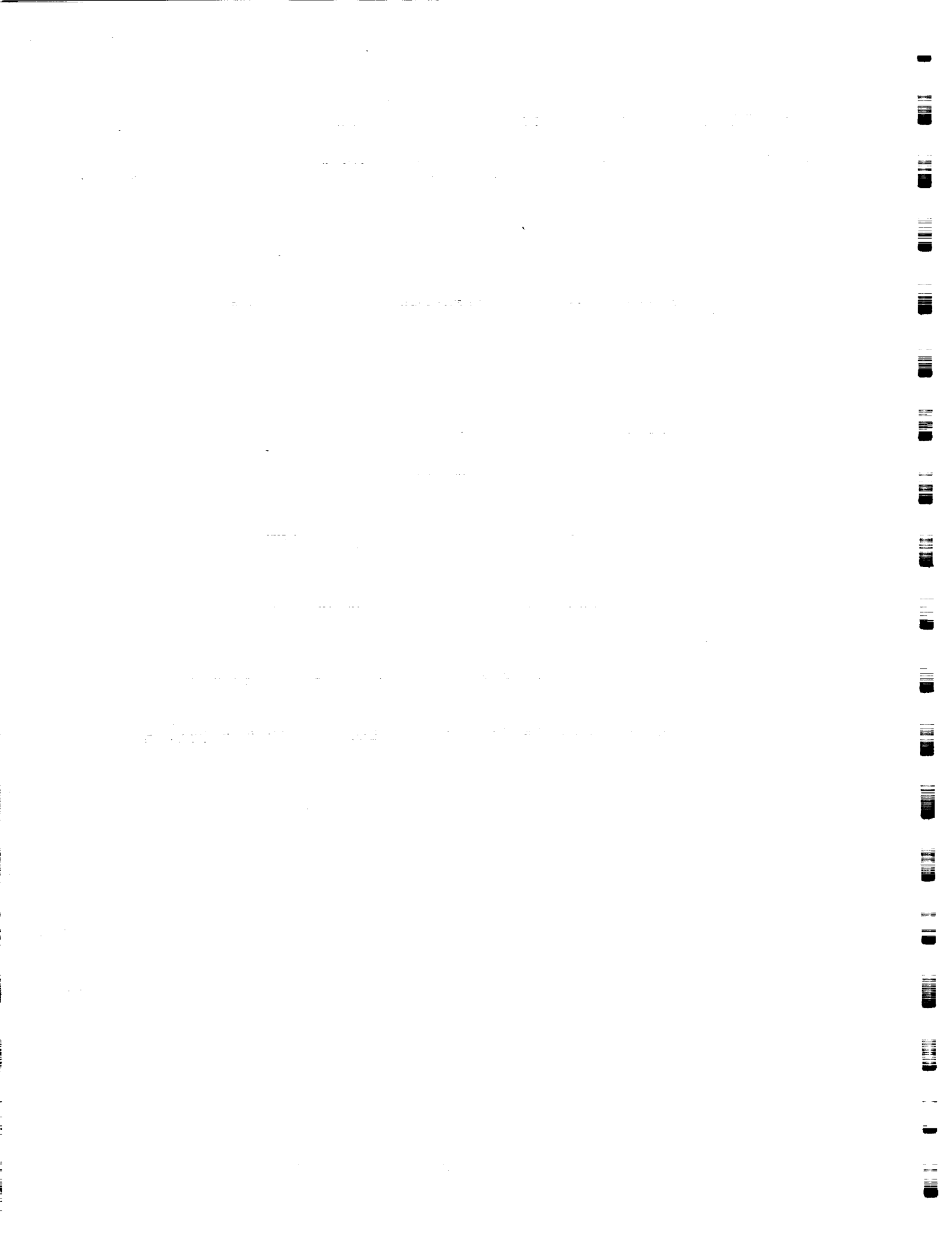

517-13
ABS ONLY

N 93-22245
146730

ABSTRACT FOR SUBMISSION TO THE U. S. AUTOMATED RENDEZVOUS & P. 2
CAPTURE CAPABILITIES REVIEW

IMP, A Performance Code

Vincent A. Dauro, Sr.

ABSTRACT

OVERVIEW

"IMP" (Integrated Mission Program) is a simulation language and code used to model present and future Earth, Moon, or Mars missions. The profile is user controlled through SELECTION from a large menu of events and maneuvers. A Fehlberg 7/13 Runge-Kutta integrator with error and step size control is used to numerically integrate the differential equations of motion (DEQ) of three spacecraft, a main, a target, and an observer. Through selection, the DEQ's include guided thrust, oblate gravity, atmosphere drag, solar pressure, and Moon gravity effects. Guide parameters for thrust events and performance parameters of velocity changes (Delta-V), propellant usage (maximum of five systems) are developed as needed. Print, plot, summary, and debug files are output.

APPLICABILITY

Events of particular interest to Automated Rendezvous are:

- INTERCEPT: The main craft maneuvers to intercept a point with respect to the target.
- FORMATION: The main craft intercepts then maneuvers to be coelliptic, (at the same relative point at a later time).
- PHASE: Checks phase angle between the main and target crafts, coasts until desired value reached.
- SIGHT: Compute line of sight (LOS), main, target, and observer.
- RENDEZVOUS: Seven different rendezvous algorithms are preprogrammed.

HISTORICALLY

"IMP" was initially coded for "MSFC SE-AERO-G" by the author while employed by Northrop Services Incorporated, Huntsville, AL (1970). In 1981, it was revived by the author, installed on the UNIVAC 1108, then the DEC VAX 11/780 at MSFC. Since then, it has been continuously improved and upgraded. Recently a version was submitted to COSMIC at the University of Georgia for sale to the public. A universal version in Fortran 77 has been debugged and is available to run on most mainframes and PC's with very little modification.

EXPERIENCE

Mission profiles and performance parameters developed by "IMP" have been used in studies of the following craft or systems.

OMV	Orbital Maneuvering Vehicle
CTV	Cargo Transfer Vehicle
STV	Space Transfer Vehicle
SIRTF	Solar Infrared Telescope Facility
LLT	Lunar Transit Telescope
SSF	Space Station Freedom (assembly and resupply)
HLLV	Heavy Lift Vehicle
SH-C	Shuttle-C
AFE	Aeroassist Flight Experiment
SEI	Space Exploration Initiative

IMP can generate profiles from liftoff to touchdown (soft or hard). Although not an interplanetary code, profiles to the Moon and to the Earth-Moon or Earth-Sun libration points may be obtained. The author will gladly discuss improvements and additions to the code.

Travis E. Dawson, Jr.

220
ABS only
146731
N93-22246
p-1

AR&C Review Presentation Abstract
November 19-21, 1991, Williamsburg, Virginia

Control of a Varying Thrust Spacecraft
for Autonomous Space Rendezvous

Before the use of autonomous rendezvous will be allowed as a substitute for man-in-the-loop control, adequate safety and mission performance will have to be guaranteed. Most autopilots for autonomous rendezvous of spacecraft assume constant thrust reaction control system (RCS) thrusters. This assumption implies either true constant thrust RCS thrusters or thrusters whose thrust levels vary very slowly. The ongoing work described in this presentation examines the autonomous rendezvous problem when varying thrust RCS thrusters are inherent in the system equations of motion. We begin with the linearized planar relative motion equations

$$\ddot{X} = 2\omega\dot{Y} + \frac{u_x(t)}{m}$$

$$\ddot{Y} = 3\omega^2 Y - 2\omega\dot{X} + \frac{u_y(t)}{m}$$

where

m = mass of body in relative motion, and
 ω = the orbital angular rate.

We then assign state variables and derive a matrix equation of motion of the form

$$\dot{x} = Ax + bu$$

where

x is the state variable vector,
A, b are the plant definition matrices, and
u is the set of control inputs.

Using this basic matrix equation, a control theory is applied which incorporates the variable nature of the RCS thrusters and develops a control law that insures global stability and optimal performance.



Faint, illegible text at the top of the page, possibly a header or title.

A line of faint text, possibly a date or a reference number.

Faint text in the lower middle section of the page.

A line of faint text near the bottom of the page.

A line of faint text at the very bottom of the page.

521-36

ABSTRACT TITLE: Laser Docking Sensor Engineering Model

N 93-22247

AUTHORS: Kent Dekome and Joseph M. Barr

146732

AFFILIATION: NASA Johnson Space Center and Lockheed Engineering & Sciences Company

P. 1

TELEPHONE/FAX: (713) 483-1453/(713) 483-5830 and (713) 483-7490/(713) 483-5830

NASA JSC has been involved in the development of Laser sensors for the past ten years in order to support future rendezvous and docking missions, both manned and unmanned. Although many candidate technologies have been breadboarded and evaluated, no sensor hardware designed specifically for rendezvous and docking applications has been demonstrated on-orbit. It has become apparent that representative sensors need to be flown and demonstrated as soon as possible, with minimal cost, to prove the capability of the technology in meeting NASA's future AR&C applications. Technology and commercial component reliability have progressed to where it is now feasible to fly hardware as a detailed test objective minimizing the overall cost and development time.

This presentation will discuss the ongoing effort to convert an existing in-house developed breadboard to an engineering model configuration suitable for flight. The modifications include improving the ranger resolution and stability with an in-house design, replacing the rack mounted galvanometric scanner drivers with STD-bus cards, replacing the system controlling personal computer with a microcontroller, and repackaging the subsystems as appropriate. The sensor will use the performance parameters defined in previous JSC requirements working groups as design goals and be built to withstand the space environment where fiscally feasible. Testing of the in-house ranger design is expected to be completed in October. The results will be included in the presentation. Preliminary testing of the ranging circuitry indicates a range resolution of 4mm. is possible. The sensor will be mounted in the payload bay on a shelf bracket and have command, control, and display capabilities using the payload general support computer via an RS422 data line.

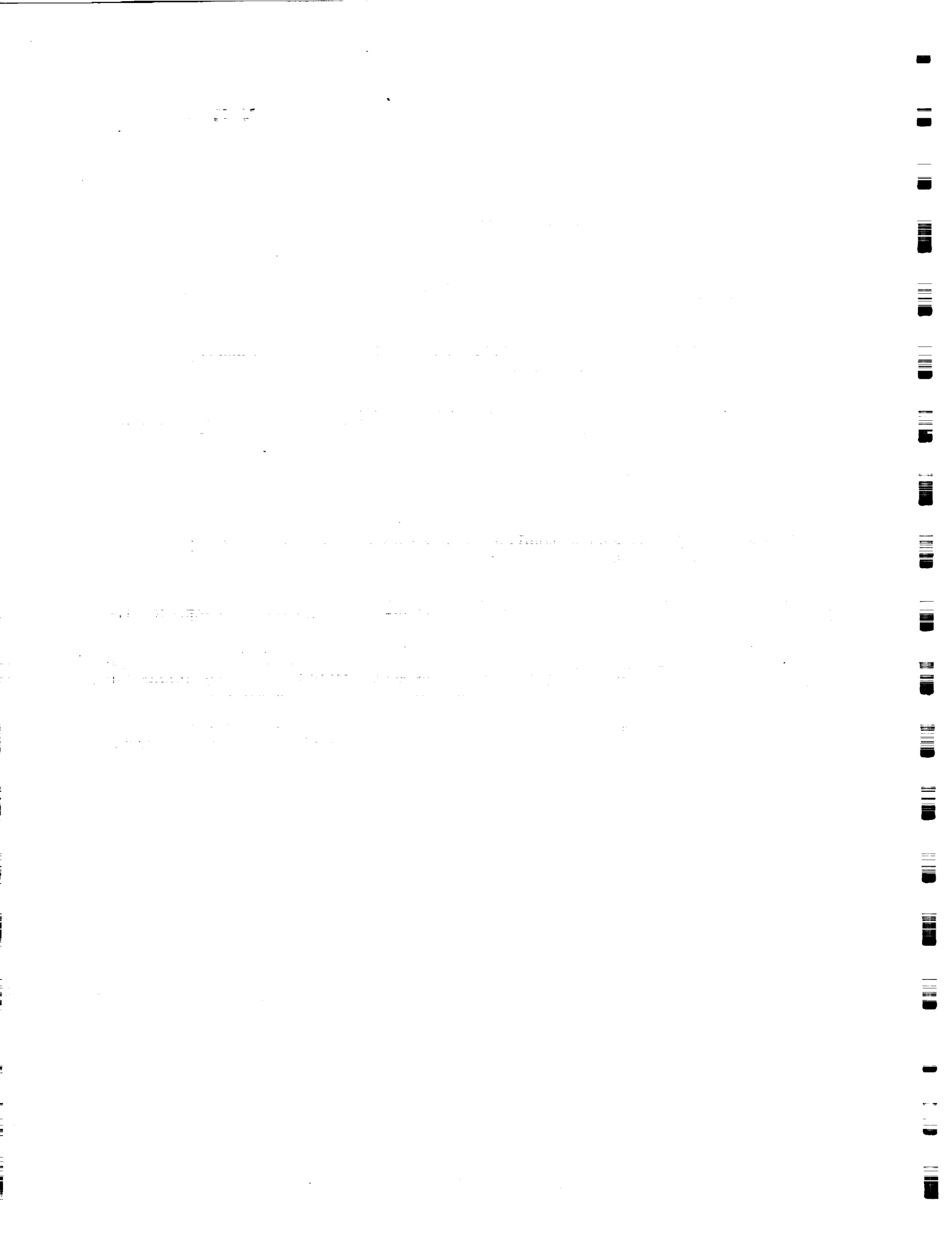

522-18
N93-22248
146733
p. 3

ABSTRACT

Title: Rendezvous Strategy Impacts on CTV Avionics Design, System Reliability Requirements, and Available Collision Avoidance Maneuvers

Author: William J. Donovan and John E. Davis, Rockwell International, Autonetics Strategic Systems Division, Telephone (714)762-2472, FAX (714)762-0766

Technical Details: Architectural studies and rendezvous trajectory modeling have indicated that the CTV approach trajectory and collision avoidance methodology will have a major impact on the design and reliability requirements of the avionics.

History: These results are based on continuing studies to define vehicle guidance, navigation and control architectures that provide high value while meeting all mission requirements.

Current Status: Initial trajectory modeling of velocities and control requirements has defined an avionics architecture. More detailed analysis and consideration of specific reliability impacts will continue.

Funding: The investigation is funded by Rockwell at \$250,000 per year.

Rockwell International is conducting an ongoing program to develop avionics architectures that provide high intrinsic value while meeting all mission objectives. Studies are being conducted to determine alternative configurations that have low life-cycle cost and minimum development risk, and that minimize launch delays while providing the reliability level to assure a successful mission. This effort is based on four decades of providing ballistic missile avionics to the United States Air Force and has focused on the requirements of the NASA Cargo Transfer Vehicle (CTV) program in 1991. Current CTV analysis efforts draw on a number of internally funded programs. Support from internal research and development (IR&D) funding to the CTV program is currently budgeted at \$250,000 in FY92.

During the development of architectural concepts it became apparent that rendezvous strategy issues have an impact on the architecture of the avionics system. This is in addition to the expected impact on propulsion and electrical power duration, flight profiles, and trajectory during approach.

A number of approach trajectories have been developed with the CTV moving from a higher orbit down to Space Station Freedom (SSF) by decelerating and with the CTV moving upward to SSF by accelerating. While all of these trajectories require similar guidance, navigation, and control (GN&C), their impact on required reliability differs markedly. Many types of system failures when accelerating from a lower orbit will result only in the CTV failing to rendezvous. If it is necessary to abort an

approach from below, the resulting CTV orbit will have an apogee that is below the orbit of SSF. However, the deceleration associated with an approach from a higher orbit will result in the CTV eventually crossing the orbit of SSF. If this orbital crossing follows a system failure resulting in a total loss of control it presents a potential risk. Any orbit for the CTV that will intersect the orbit of SSF places additional requirements on the CTV design. The impact on the avionics (and related attitude control system components) is to require a higher level of fault tolerance to assure continued control when in an orbit at or above the orbit of SSF.

While the direction of approach has the ability to minimize the possibility of collision, the inclusion of a collision avoidance maneuver (CAM) has proven to still be required. A wide range of possible CAM methodologies has been developed and evaluated based on the safety provided versus their impact on system design. Many relatively straightforward concepts prove either to be difficult to implement or to require major portions of the system to remain operational through faults. Because a CAM will often result from an extensive failure of the system, an optimum solution will require a minimal hardware set to remain operational.

The CAM concept developed by Rockwell that best meets these requirements is based on an approach from a lower orbit and an approach guidance mechanization with a closing velocity decreasing with distance from SSF. The approach from below allows a reversal of the approach by decelerating the CTV. An approach from a higher orbit would require a CAM consisting of either an acceleration to a higher orbit that could deteriorate to a crossing orbit, a lateral divert that could result in a crossing orbit, or a deceleration to pass below SSF that could also create a crossing orbit. Maneuvers that depend on passing SSF must also consider available clearance. The proposed approach guidance concept includes a velocity decreasing with distance in order to allow sufficient time for the CAM system to reverse the closing velocity at all distances.

In any type of CTV failure it can be assumed that the CAM control system has available the attitude, velocity, and position of the CTV. From this information the CAM system can determine what thruster or thrusters can best counteract the motion towards SSF and decelerate the CTV to a lower orbit. If a total system failure occurs, these data may be what was last recorded prior to the failure. While this data will not be current, its accuracy will be sufficient to allow the CAM to proceed. Preliminary analysis of the mass properties of the CTV has indicated that firing of thrusters without the guidance or control system being functional would be effective in countering the motion toward SSF. Prolonged firing without other controls would eventually result in a loss of stability. However, this will occur after a sufficient decrease in velocity to allow clearance. A CAM while departing SSF (without a payload) would result in the same thrust being applied to a lesser mass. This will cause a loss of stability in less time. However, the greater acceleration of the lesser mass would provide an acceptable displacement before stability was lost.

This concept continues to be refined in greater detail. It currently provides an

effective CAM with a simplified system architecture. Additional analysis will translate the system and reliability impacts to a detailed system architecture. Open issues remain in the de-orbiting following CAM and possible reentry over land areas.

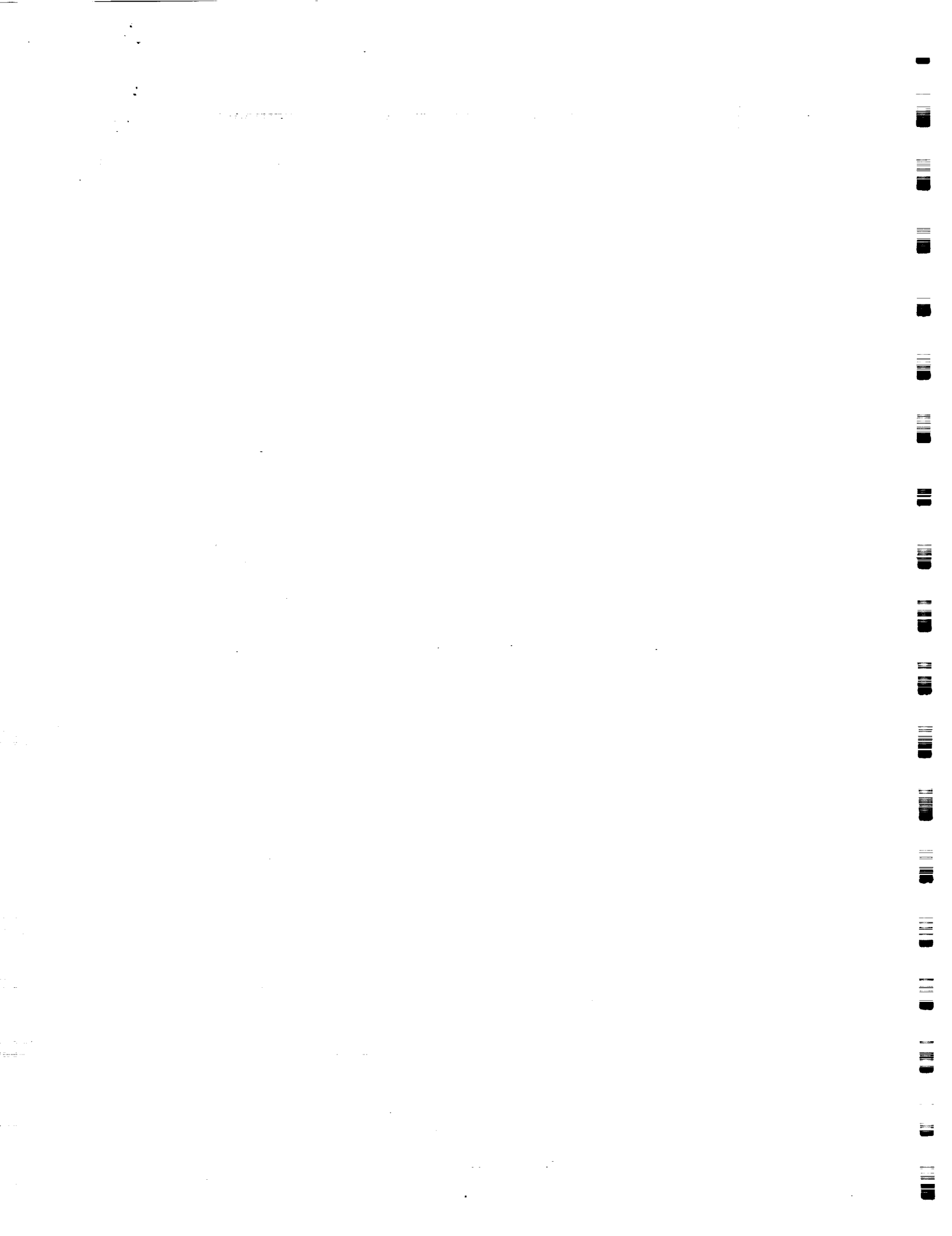

22-10
N 93 A 22249

146734
P-3

To: Barbara Askins, NASA/HQ, Code MD, AR&C Review
Chairperson

From: Andrew Dougherty, NASA/Goddard, Code 441, Mission
Systems Engineering Manager

Date: September 30, 1991

Subject: Abstract Submittal for AR&C Review

Title: The Real-time Operations of the Space Shuttle
Orbiter during Rendezvous and Proximity Operations

Authors: Andrew Dougherty Chris Meyer
 NASA/Goddard, MC 441 Rockwell Space Ops Co.
 (301) 286-1334 (713) 483-0875
 fax: (301) 286-2014
 ADOUGHERTY on GSFCMail

Details: The Space Shuttle Orbiter is the only U.S. spacecraft in operation today that routinely performs an orbital rendezvous with another spacecraft. The trajectory planning and training of both flight crews and ground operations personnel required to achieve a 100% success rate is considerable. The preflight planning and training can be reduced through very simple design considerations of a new space vehicle.

History: The rendezvous capability of the Space Shuttle Program was inaugurated in 1983 with the successful deployment and retrieval of the SPAS-01 satellite. The capability to rendezvous with, capture, and then repair a satellite in-orbit was demonstrated in 1984 with the repair of the Solar Maximum satellite. The program expanded the capabilities of the Orbiter with the successful SPAS/IBSS STS-39 mission. This mission demonstrated the flexibility of the software onboard the Orbiter during the 38 hour free flight of the SPAS/IBSS satellite which contained more than 20 orbital burns to study the plume contours of the Orbital Maneuvering Engines of the Orbiter. The Orbiter remained in the close vicinity of the SPAS during the entire freeflight while performing these precise maneuvers.

Maturity: The flight software of the SSP Orbiter is very mature and under configuration control at the Johnson Space Center. It is extensively tested with each new OI software delivery. It uses the Lambert targeting methodology.

The ground software used by controllers in the Mission Control Center also uses Lambert Targeting, but contains many features not found in the flight software. It allows much greater flexibility in planning and trajectory redesign than the onboard software. Few enhancements to either the flight or ground software have been made. Mostly due to the complexity of the change process and the significant cost of those changes.

Results: The successful operation of the Space Shuttle Orbiter are accomplished by utilizing both the onboard and ground software, but the software is different. There is little commonality between the software, different user interfaces (the very same software used for premission planning and real-time operations have vastly different interfaces), significantly different capabilities. This means maintaining two or more sets of software. Much can be gained by unifying the software used in flight and premission operations.

The knowledge and techniques required to execute an orbital rendezvous and capture is vastly different than the ascent, aborts, and re-entry phases. Specialization to an on-orbit pilot and reflight of crews with rendezvous experience would reduce the amount of training required.

In ground operations, a specialized cadre of controllers is used in Shuttle operations during rendezvous operations. The responsibilities and functions of the controllers is still spread among several positions. This is due to the decades old software and hardware used in the Mission Control Center. A modern, distributed, workstation based control center should be mandated. The ability to easily and quickly upgrade both the software and the hardware it is hosted on should be designed into the infrastructure of the program. The use of graphical displays and expert system-like software to assist the controllers in fault detection, isolation, and reconfiguration should be used. The premission planning and onboard software should be similar, if not identical, to enable the premission design team and the real-time controllers to be the same people and reduce the amount of software configuration management required.

Spacecraft operations must be included in the design requirements of any new spacecraft capable of Rendezvous and Capture operations. Unless considered early in the design phase, these requirements impose very costly redesign efforts or very restrictive limitations on the operations of the vehicle. You could end up like Space Station Freedom whose solar arrays are damaged during an Orbiter approach due to plume impingement effects. Another example of plume effects was on the OMV, where the short range radar and

communication antennas were in the direct flowfield of the orbit transfer engines, probably with the same result as the SSF solar arrays.

Another example from OMV was the requirement for a high level of autonomy in the onboard rendezvous software, but the solar array/battery combination was so underpowered that the vehicle had to be 'put to sleep' for so much of the orbital mission that little of the autonomy was ever realized by the program. The OMV is a pretty good place to look to find out how not to build a new vehicle for rendezvous and capture operations.

Funding: All the experience gained of the Rendezvous and Proximity Operations capabilities of the Space Shuttle Orbiter were gained at the Johnson Space Center.

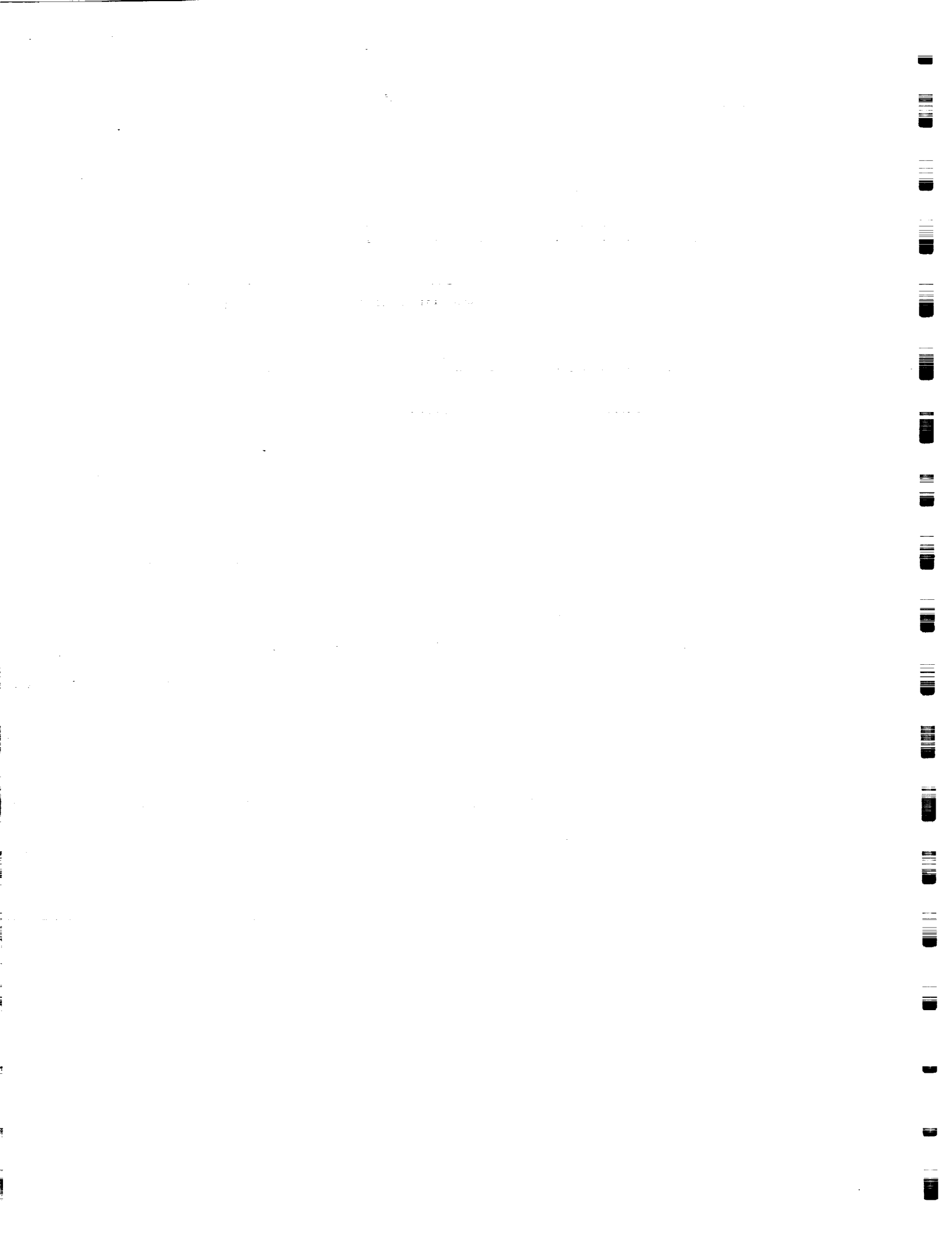

24-36

NBS ONLY
146735

N93-22250

TITLE: COHERENT DOPPLER LIDAR FOR AUTOMATED SPACE VEHICLE,
RENDEZVOUS, STATION-KEEPING AND CAPTURE

AUTHOR: JAMES A. DUNKIN

MAIL CODE: EB23

ORGANIZATION: NASA/MARSHALL SPACE FLIGHT CENTER

PHONE: (205) 544-3690

FAX: (205) 544-2659

ABSTRACT:

A number of studies dating back as early as the late 1960's have documented the potential of lidar as an enabling technology for automated space vehicle rendezvous, and capture. Few of these studies considered the use of coherent lidar. Coherent lidars are lidars which incorporate lasers with line widths narrow enough to permit direct measurement of velocity via doppler shift. Although coherent lidar has been used for ground based atmospheric velocity measurements for over twenty years, the technology involved CO₂ gas lasers, which because of problems with packaging and consumables, were not well suited to rendezvous and capture applications.

Recent advances in eye-safe, short wavelength solid-state lasers offer real potential for the development of compact, reliable, light-weight, efficient coherent lidar. Laser diode pumping of these devices has been demonstrated, thereby eliminating the need for flash lamp pumping, which has been a major drawback to the use of these lasers in space based applications. Also these lasers now have the frequency stability required to make them useful in coherent lidar, which offers all of the advantages of non-coherent lidar, but with the additional advantage that direct determination of target velocity is possible by measurement of the doppler shift. By combining the doppler velocity measurement capability with the inherent high angular resolution and range accuracy of lidar it is possible to construct doppler images of targets for target motion assessment.

A coherent lidar based on a Tm,Ho:YAG 2-micrometer wavelength laser was constructed and successfully field tested on atmospheric targets in 1990. This lidar incorporated an all solid state (laser diode pumped) master oscillator, in conjunction with a flash lamp pumped slave oscillator. Solid-state laser technology is rapidly advancing, and with the advent of high efficiency, high power, semiconductor laser diodes as pump sources, all-solid-state, coherent lidars are a real possibility in the near future.

MSFC currently has a feasibility demonstration effort under way which will involve component testing, and preliminary design of an all-solid-state, coherent lidar for automatic rendezvous, and capture. This two year effort, funded by the Director's Discretionary Fund is due for completion in 1992.

A Synthetic Environment for Visualization and Planning of Orbital Maneuvers

Stephen R. Ellis
Aero-Space Human Factors Research Division
NASA Ames Research Center, Moffett Field, CA 94035
and U.C. Berkeley School of Optometry
email: silly@eos.arc.nasa.gov
fax: 415 604-3729
voice 415 604-6147

S25-14
HRS ONLY
H16736
P, 2

Arthur J. Grunwald
TECHNION
Haifa, Israel
and Aero-Space Human Factors Research Division
NASA Ames Research Center

Abstract:

An interactive proximity operations planning system, which allows on-site planning of fuel-efficient, multi-burn maneuvers in a potential multi-space-craft environment has been developed and tested. This display system most directly assists planning by providing visual feedback in a synthetic virtual space that aids visualization of trajectories and their constraints. Its most significant features include 1) an "inverse dynamics" algorithm that removes control nonlinearities facing the operator and 2) a stack-oriented action-editor that reduces the order of control and creates, through a "geometric spreadsheet," the illusion of an inertially stable environment. This synthetic environment provides the user with control of relevant static and dynamic properties of waypoints during small orbital changes allowing independent solutions to otherwise coupled problems of orbital maneuvering.

The display provides a format for conveniently visualizing, creating or editing multiburn orbital maneuvers. An experiment has been carried out in which briefly trained operators were required to plan a trajectory to retrieve an object accidentally

separated from a dual-keel space station. The time required to plan these maneuvers was found to be predicted by the direction of the insertion thrust and did not depend on the point of separation from the space station. Analysis of the operators' performance also indicates that while they are able to quickly plan feasible solutions to complex orbital problems, optimal solutions for multiburn maneuvers will require additional display enhancements. Current work is directed to developing these new symbolic enhancements as well as improving the human interface to the display. Formal papers in archival journals of test results have been accepted for publication and should appear in mid 1992..

Versions of the display software have been distributed to a number of industrial and government laboratories within the U.S. and abroad. This project has developed from previous work on visualization tools for air traffic and has been funded by OAET R&D and Space Exploration Initiative funds. Cuts in '92 SEI budget for human factors may jeopardize the future of this research and development. Funding requirements are

approximately \$70K/year for 1 - 2 years to complete work in progress.

References:

Ellis, Stephen R. and Grunwald, Arthur J. (1989)
The dynamics of orbital maneuvering: design and evaluation of a visual display aid for human controllers. Proceedings of the AGARD FMP symposium on Space Vehicle Flight Mechanics. 13-16 November, 1989 Luxembourg, 29-1 - 29-13.

Grunwald, Arthur J. and Ellis, Stephen R.(1988)
Interactive orbital proximity operations planning system NASA TP 2839, NASA Ames Research Center.

Grunwald, Arthur J. and Ellis, Stephen R.(1992) A visual display aid for orbital maneuvering: design considerations. AIAA Journal of Guidance and Control (forthcoming)

Grunwald, Arthur J. and Ellis, Stephen R.(1992) A visual display aid for orbital maneuvering: experimental evaluation. AIAA Journal of Guidance and Control (forthcoming).

U.S. Automated Rendezvous and Capture Capabilities Review
Category 4 - Operations

Abstract Title: Autonomous Rendezvous and Docking Operations of Unmanned Expendable Cargo Transfer Vehicles (e.g. Centaur) with Space Station Freedom

Author: Brian R. Emmet

Affiliation: General Dynamics, Space Systems Division
P.O. Box 85990, San Diego, Ca. 92186-5990
M.Z. C1-8360
Telephone: (619) 547-3865
FAX: (619) 547-7162

Technical Details:

This paper describes the results of the feasibility study of using Centaur or other CTV's to deliver payloads to the Space Station Freedom (SSF). During this study we examined the requirements upon unmanned cargo transfer stages (including Centaur) for phasing, rendezvous, proximity operations and docking/berthing (capture).

Phasing - We examined different ascent trajectories and phasing options to determine:

- Performance
- Velocity requirements
- Power requirements
- Time on orbit
- Contingency operations
- Launch windows

Crew Control Capabilities - We examined different command modes for the transfer vehicle.

- Fully Autonomous
- Fully Manual
- Supervised Automatic
- Preprogrammed Operations

Control Locations - We explored various options for centralizing the primary control authority of the transfer vehicle.

- Ground Based Teleoperated
- SSF Based Teleoperated
- SSF Based Automatic
- Vehicle Based Automatic

SSF Operational Constraints - We researched the SSF constraints regarding operations in close proximity with this manned base.

- Collision Avoidance
- Contamination Avoidance
- Systems Safing
- SSF Control Authority

Historical Origin of Capabilities:

General Dynamics has been involved in space transportation vehicle operations for thirty years, beginning with Air Force ICBM work. Throughout that time GD has worked on various studies and programs related to space platforms, manned and unmanned space transportation vehicles, components of space transportation architectures (e.g. boosters), and space exploration. One of our more recent company funded efforts into the Autonomous Rendezvous and Docking area stems from our feasibility study of *"Atlas Deliveries to Space Station Freedom"*.

Level of Maturity/Current Funding:

The results of this study were intended to provide top level requirements to assess the feasibility of using Atlas and Centaur in a SSF resupply role. GD currently has 3 and 6 DOF simulations to study Autonomous Rendezvous and Docking (AR&D), however no studies are currently underway at this time. Continuation of the Atlas/Centaur operational studies are anticipated pending SSF Program Office incorporation of Expendable Launch Vehicles into the logistics program. We also anticipate analyses of the CTV in support of the National Launch System (NLS) activities.

527-13
ABS ONLY
N 8 - 22253
P-1

TRAC BASED SENSING FOR AUTONOMOUS RENDEZVOUS

by

Louis J. Everett¹
and
Leo Monford²

ABSTRACT

This paper describes a TRAC (Targeting Reflective Alignment Concept) based sensing system for use in an autonomous rendezvous and docking experiment. The proposed experiment will utilize a COMET (COMmercial Experiment Transporter) based target satellite and a second chase vehicle. The sensor system consists of a target mounted on the target vehicle and a vision based sensor on the chase vehicle. The target has both active and passive components to enable the evaluation of both technologies. The chase vehicle will possess structured lighting and a single off the shelf camera.

Lighting will be provided by several strategically placed "kilo-bright" LEDs capable of emitting 2500 millicandela with 40 milliwatts of input. The structured lighting will be used to eliminate background illumination caused by earth shine and solar glare. The proposed CCD camera will utilize a fixed focal length, variable iris lens and a bandpass filter tuned to the LED color. Complex vision processing can be avoided using the structured lights, therefore data is expected to be obtained at a rate of several cycles per second.

Preliminary tests indicate the targeting system is capable of providing data from 1 meter to 300 meters range.

¹Associate Professor, Mechanical Engineering Department, Texas A&M University, College Station, Texas 77843

²NASA JSC, VAN Bld Room E3, Houston, Texas 77058

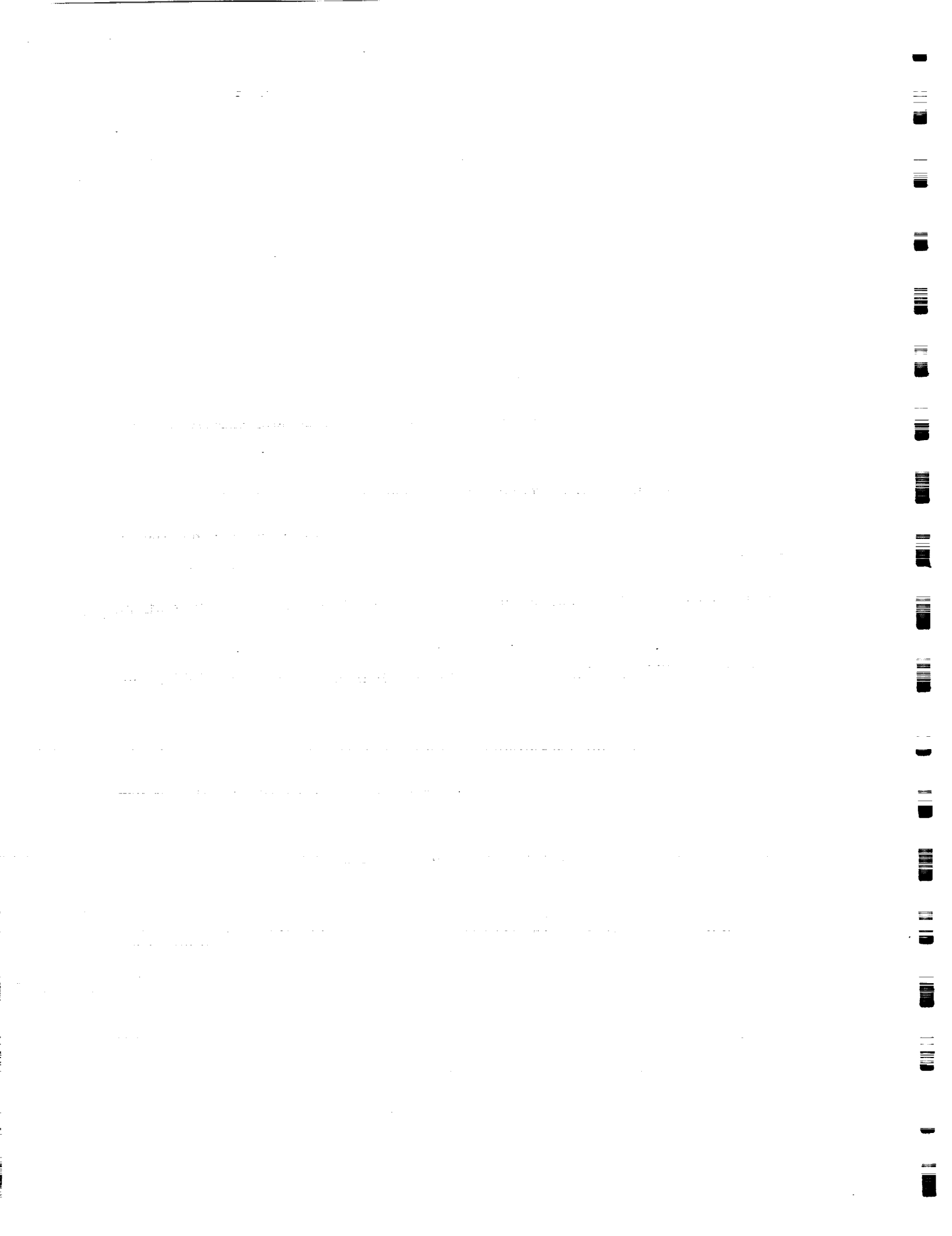

208-18

ABS ONLY

N 93-22254

P. 1

Edward Falkenhayn
Goddard Space Flight Center

ABSTRACT FOR THE U.S. RENDEZVOUS AND CAPTURE CAPABILITIES REVIEW

Abstract: Flight Support System (FSS) Docking and Umbilical Services Systems

The Satellite Servicing Project at GSFC in the early 80's developed a facility for servicing observatories in orbit when docked on the shuttle. The facility includes a three point docking ring and one or two umbilicals to provide power, data and command capability to docked payloads. This facility was used in the 1984 repair of the Solar Maximum satellite. It will be used for the Hubble repair mission in 1993, and it is planned to be used on the Explorer Platform retrieval mission in 1995 and for servicing AXAF in the late 90's.

The basic three point docking mechanisms and umbilical interfaces were adopted by the OMU Project for that vehicle's remote rendezvous and docking mission capability. This would have assured a common interface for a serviceable payload for either shuttle based or remote servicing, i.e. HST. For OMU remote servicing, quick reaction docking latches were under development when that Project was canceled.

Although there is no remote servicing capability being funded at present, the EOS spacecraft configuration does include three pins compatible with the FSS latches as a contingency planning measure.

A presentation for the 3-day, Williamsburg review, would include:

- a. a complete description of the three point docking configuration
- b. a description of the docking alignment tolerances of the system
- c. a description of the existing electric umbilical configuration, operation, and services available therewith
- d. a description of the refueling umbilical being procured for testing this winter

Faint, illegible text, possibly bleed-through from the reverse side of the page. The text is arranged in several horizontal lines across the middle of the page.



ON-BOARD FAULT MANAGEMENT FOR AUTONOMOUS SPACECRAFT

Lorraine M. Fesq
Amy Stephan
Susan C. Doyle
Eric Martin
Suzanne Sellers



Engineering and Test Division
One Space Park
Bldg. R9/1869
Redondo Beach, CA 90278
(213) 814-6073 Phone
(213) 814-8068 FAX

52-18
ABS. ONLY
146740
P. 2
N93-22255

Statement of technical details of the capability being described

The dynamic nature of the Cargo Transfer Vehicle's (CTV) mission and the high level of autonomy required mandate a complete fault management system capable of operating under uncertain conditions. Such a fault management system must take into account the current mission phase and the environment (including the target vehicle), as well as the CTV's state of health. This level of capability is beyond the scope of current on-board fault management systems.

This presentation will discuss work in progress at TRW to apply artificial intelligence to the problem of on-board fault management. The goal of this work is to develop fault management systems that can meet the needs of spacecraft that have long-range autonomy requirements.

We have implemented a model-based approach to fault detection and isolation that does not require explicit characterization of failures prior to launch. It is thus able to detect failures that were not considered in the failure and effects analysis. We have applied this technique to several different subsystems and tested our approach against both simulations and an electrical power system hardware testbed.

We present findings from simulation and hardware tests which demonstrate the ability of our model-based system to detect and isolate failures, and describe our work in porting the Ada version of this system to a flight-qualified processor. We also discuss current research aimed at expanding our system to monitor the entire spacecraft.

History of the origins & evolution of the capability

TRW has been actively researching the application of artificial intelligence to on-board fault management since 1987. Initial work focused on rule-based and fault-modeling approaches, but because these methods can only detect a subset of possible failures, they were deemed inadequate for autonomous fault monitoring. In 1988, we began to examine a model-based fault-management technique called constraint suspension and have success-

fully used this technique to isolate faults in both simulations and an electrical power system testbed. We have developed a tool for building model-based diagnostic systems, called MARPLE, and used this tool to build in-house fault management systems as well as a contingency analysis monitoring system for the NASA LeRC Space Station Freedom power testbed.

The level of maturity of the capability

The MARPLE fault management approach is in its third year of development. It has been through the design, code, and prototype phases. We are currently addressing the remaining issues to make MARPLE a realizable on-board system. These issues include verification and validation, real-time response, and integration into a flight software package.

Test experience and/or experimental results

The MARPLE system has been through two years of prototype testing. A MARPLE-based power diagnostic system was first tested against a software electrical power system simulator. This simulator enabled extensive testing of many fault scenarios, including sensor failures, component degradations, and external threats such as laser and pellet attacks. This same diagnostic system was then integrated into a hardware power system testbed, and failures were induced into the actual hardware (to the extent allowed by the power engineers). These hardware tests demonstrated one of the major strengths of the MARPLE-based technique -- its ability to isolate failures without characterizing the symptoms a priori.

Capabilities and limitations of the MARPLE technique were realized through these tests. Modifications are currently planned to enable MARPLE to realize its own limitations and thereby avoid false diagnoses.

Source/sponsorship and current funding estimates

This effort is being pursued on Internal Research and Development funds. In addition, NASA LeRC sponsored a contract effort to apply the results of this IR&D to the Space Station Freedom Power System.

Image Based Tracking Approaches to AR&C at the Johnson Space Center

Timothy E. Fisher
NASA Johnson Space Center
Tracking and Communications Division
Phone: 713/483-1456
FAX: 713/483-5830
Email: fisher@ttb.jsc.nasa.gov

530-19
ABS-ONLY
1467/41
P: 3

Alan T. Smith
Lockheed Engineering and Sciences Company
Phone: 713/483-1497
Email: smith@ttb.jsc.nasa.gov

Automated Rendezvous and Capture (AR&C) requires the determination of the six degrees of freedom relating two free bodies. Sensor systems that can provide such information have varying sizes, weights, power requirements, complexities and accuracies. One type of sensor system which can provide several key advantages is an *image based* tracking system, or better known as a machine vision system. By *image based tracking* we mean that the sensor is some imaging device such as one or more video cameras, from which the tracking parameters necessary to support the rendezvous and capture operations (range, attitude, etc.) can be derived. Image based tracking offers many advantages such as relative hardware simplicity and reprogrammability. These advantages must be weighed against the disadvantages of these systems, such as limited operational range, poorer accuracy at greater distances and sensitivity to lighting conditions. However, with properly designed algorithms and targets these disadvantages can be minimized for many important applications. Rigorous testing in realistic environments can further increase the robustness and reliability of these systems. This presentation describes the facilities used at JSC to support AR&C image based tracking development and the details of our binocular stereo approach to image based tracking.

At the Johnson Space Center (JSC), we have developed the Image Based Tracking Laboratory (IBTL) to explore these issues and to develop realistic, robust and functional automated rendezvous and capture image based tracking systems. A key element of our laboratory is the ability to accurately simulate the visual environment encountered in space. This environment is simulated by a large flat black room with six strategically located 1500 Watt lamps to simulate various sun angles, and a 5000 Watt spot light to create the harsh shadows and lighting conditions experienced in orbit. For completeness, we have also added starfield and earth backgrounds, a Martian landscape and various spacecraft models. The IBTL is equipped with various image

processing equipment for developing image based tracking algorithms and mobile robots to simulate spacecraft. A Pipelined Image Processing Engine provides rapid prototyping of algorithms and is augmented with a Datacube based blob analysis system and various PC based frame grabbers and image processors. The laboratory provides JSC researchers the capability to rapidly explore image based tracking algorithms in a realistic environment.

The image based tracking approaches being pursued by JSC include an optical correlator for non-cooperative model based recognition, passive stereo, passive and active monocular techniques for cooperative target recognition. This presentation will discuss the passive stereo techniques for determining the range and attitude measurements necessary to support AR&C. The optical correlator and some monocular techniques are described in separate presentations at this technical review.

In these techniques we must operate within the limitations imposed upon us by the system. Since the operational range of image based tracking systems is limited, we must assume that some form of tracking ability exists that will bring the two spacecrafts to within 100 meters of each other. We also assume that the approach to the target does not require our sensors to look into the sun. We do not, however, require an empty space background for our target vehicle; we can accommodate Earth, moon and star field backgrounds. For simplicity, we have also assumed that coarse attitudes of both the target and rendezvous vehicles are known so that the docking target will be visible to the rendezvous vehicle. If this were not the case, we would have to maneuver the rendezvous vehicle around the target vehicle until the docking target came into view.

Under these assumptions, we are developing a stereo based range and attitude determination system. This system utilizes three parallel looking video cameras in a stereo configuration. The three cameras are spaced so that two cameras are as far apart as possible (on opposite sides of the vehicle) to yield the greatest range accuracy at long ranges. The third camera is placed between the other cameras to provide a shorter baseline for the terminal phase of the AR&C and also serves as a redundant camera should one of the outer cameras fail. During the initial rendezvous phase we use the outer cameras to provide range and bearing information to the target vehicle. As the vehicles get closer, the docking target will become resolvable and accurate attitude information will be available. The docking target is a pattern of markings in a known geometry. The three-dimensional coordinates of the markings are calculated after locating them in the left and right cameras of the stereo pair. Since the geometry of the marks is known, the ranges and bearing angles to the individual marks will allow us to determine the attitude of the docking target.

This work is still in the developmental phase. We have successfully provided range and attitude measurements in our laboratory for small distances (less than 10 meters) and simple backgrounds. The system has been interfaced to a mobile robot which can simulate a rendezvous with the docking target in the IBTL. The system

accuracy has been measured using the very accurate six degree-of-freedom positioner available at JSC. Additional work will include the improvement of the target segmentation--the extraction of the alignment target from a complex image. This will include complicated backgrounds at infinite range, complicated spacecraft backgrounds and specular reflections off of the target spacecraft. Additional research will be conducted to develop alternate passive targets which ease the segmentation task and improve the robustness of the system.

Image based tracking offers many attractive features for an AR&C navigation and guidance system. These systems require minimal changes to the existing spacecraft hardware by making use of available cameras and adding a video processor to the rendezvous vehicle and a passive alignment target to the target vehicle. Still, with these advantages, image based tracking must prove that it can function reliably and robustly enough to achieve mission success. Future JSC research is intent on addressing these issues and demonstrating that image based tracking is, indeed, reliable and robust enough for real automated rendezvous and capture missions.

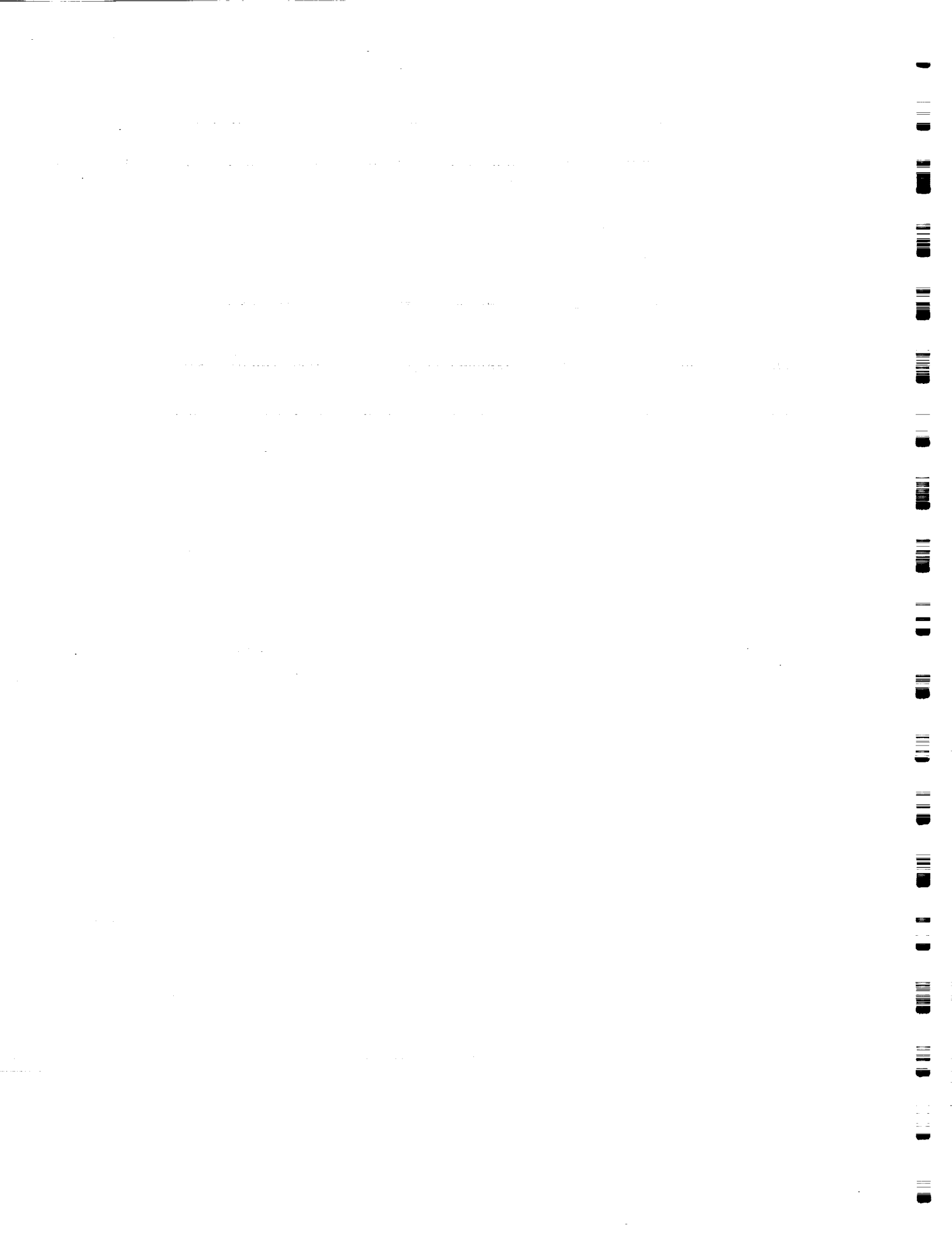

Automated Rendezvous and Proximity Operations

531-18

ABS ONLY
N 93-22257
14619

Anton F. Flecklin, II
Rockwell International
Space Systems Division
12214 Lakewood Blvd
Downey, CA 92649 Mail Code FC94

P. 3

Tel: (213) 922-0238
FAX: (213) 922-0472

Overview

IR&D efforts in recent years have focused on effective means of performing automated rendezvous and proximity operations. The primary focus for application has been to the Space Shuttle Orbiter and potential derivations, such as the Reusable Cargo Vehicle (RCV), studied in FY 1990. All candidate vehicle mission scenarios have included approach to docking or berthing with the Space Station Freedom (SSF). Results to date indicate that application of appropriate guidance algorithms can reduce docking contact or relative offset conditions, resulting in potential simplification of capture systems.

Historical Development

Mr. G. Carden/Rockwell-SSD developed guidance algorithms for a controlled approach to target vehicles under 1988 and 1989 IR&D studies to review the contact conditions expected for Orbiter-SSF docking. These candidate algorithms (Guided V-Bar, Guided R/V-Bar, Range Gate, Parallel V-Bar, and Bearing Guidance) were incorporated in the Docking and Berthing Simulation (DBSIM) and executed using a "paper pilot." In order to assure equivalence between the guidance computations, a nominal relative navigation state was used, equivalent to the assumption of a laser-based docking sensor (LDS). Figure 1 presents an overview of the simulation configuration.

The resulting contact conditions were then compared to determine the algorithms exhibiting at least acceptable performance relative to the docking contact or stability conditions for berthing as defined at that time (see Figure 2). As a rule, automated control achieved or significantly improved upon the desired contact or stability criteria.

Additional considerations for automated docking or berthing included Reaction Control System (RCS) propellant consumption and plume impingement. Runtime orbiter-equivalent thruster firings were recorded and assessed using a plume impingement program to determine the total forces and moments applied to the target vehicle. Total delta velocity (Δv) was also recorded and totalled for the approach profile to estimate the equivalent propellant requirements. This was of additional benefit in determining the sensitivity of the approach technique while demonstrating recovery to the desired approach profile given dispersed initial conditions.

Future Application

Current plans are to incorporate the automated rendezvous and proximity operations guidance algorithms into the Avionics Development Laboratory (ADL). The commands will then be used to drive ADL hardware, emulating the relative translational motion of an approaching vehicle to a capture mechanism. This provides for a three degree-of-freedom (3 DOF) motion assessment of the contact conditions, with later incorporation of an air-bearing device to provide the remaining capability to assess 6-DOF relative dynamics. ADL capability to integrate LDS hardware and incorporate sensed relative navigation signals is also under consideration in order to demonstrate fully closed-loop proximity operations with candidate sensor suites.

The ADL provides a future host site for assessing and/or validating candidate guidance and navigation concepts during rendezvous and proximity operations. Present IR&D efforts, while focused on utilization in the RCV, are applicable to studies of other potential vehicles and missions, such as lunar return, Mars visit, or even unmanned transfer vehicles. Incorporation of the driving algorithms into the ADL will provide rapid study of approach and separation techniques where the level of automation or autonomy require system level definition.

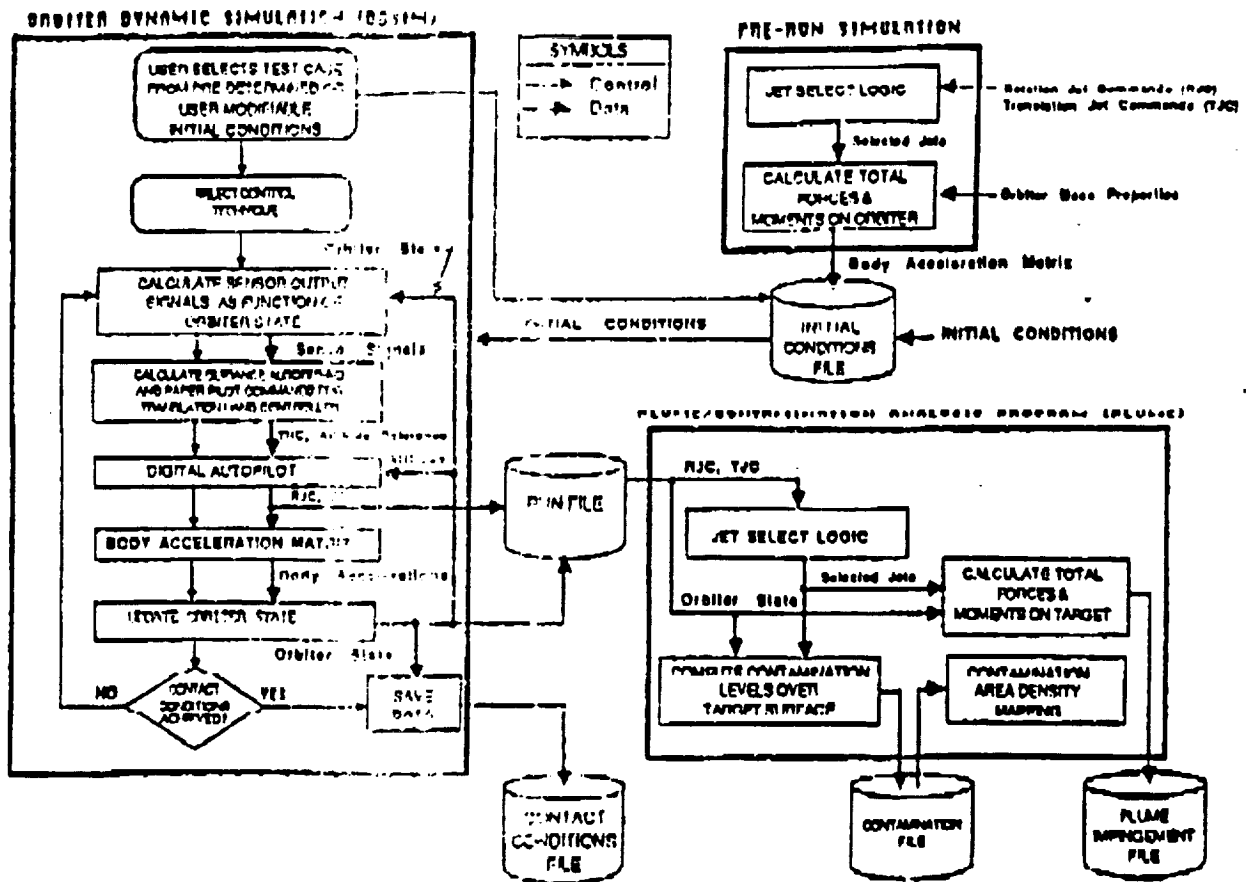

Figure 1. Docking/Berthing Simulations

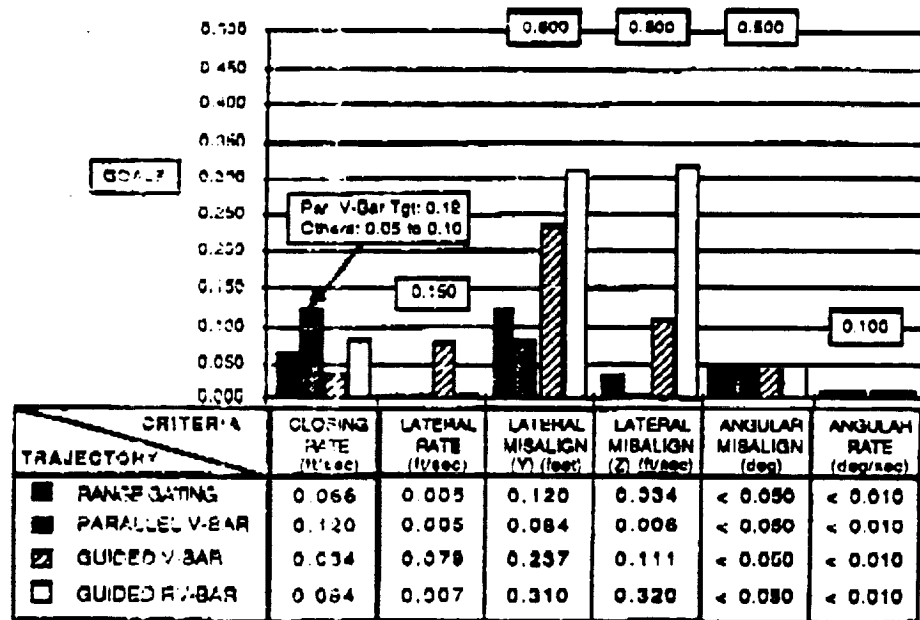

Figure 2. Contact Conditions vs. Selected Trajectory

ORIGINAL PAGE IS OF POOR QUALITY

[Faint, illegible text covering the majority of the page, likely bleed-through from the reverse side.]



532-36
ADS. ONLY
N93-222583

"LADAR Vision Technology for Automated Rendezvous and Capture"

Randy W. Frey

P. 1

Autonomous Technologies Corporation Orlando, FL
Phone 407-281-1262, Fax 407-282-9510

LADAR Vision Technology at Autonomous Technologies Corporation consists of two sensor/processing technology elements: high performance long range multifunction coherent Doppler laser radar (LADAR) technology; and short range integrated CCD camera with direct detection laser ranging sensors. Algorithms and specific signal processing implementations have been simulated for both sensor/processing approaches to position and attitude tracking applicable to AR&C. Experimental data supporting certain sensor measurement accuracies have been generated.

Application of LADAR technology to rendezvous and docking was first addressed by ATC personnel in 1983 when Martin Marietta studied a LADAR system for Orbital Maneuvering Vehicle (OMV). A 10 Watt/5 inch CO₂ LADAR was shown to provide 50 km acquisition against a non-augmented Hubble Space Telescope sized target. Development issues were determined to be significant for such a system however, and advances in technology were desired. ATC was formed in 1985 and innovations in LADAR technology addressing AR&C were proposed via the Small Business Innovation Research (SBIR) Program from 1987 to the present.

A single sensor solution (1 cu.ft./50#) to AR&C has been proposed (1990) that meets the Laser Docking Sensor Flight Experiment Program requirements where target enhancements (retro-reflectors) are permitted. A high performance Carbon Dioxide (CO₂) laser heterodyne Doppler radar system has been prototyped under a NASA/JSC SBIR Phase II technology program. Hardware scaling to an LDS flight configuration was shown to be supported by current military programs. Simulations for this CO₂ LADAR has shown capability for LDS long range (100 nmi.) rendezvous acquisition and position tracking through close range 6DOF Pose tracking for proximity operations (near zero range) addressing capture/bearthing.

A 6DOF tracking approach not requiring target enhancements (skin track) is also being developed by ATC under SDIO SBIR sponsorship. This LADAR Vision Processor technology implements a CAD model based tracking approach utilizing the 3D geometry of objects. Robotic adaptive grasping based on 6DOF track of both object and end-effector has been demonstrated in a laboratory setting. Experimental evaluation of the sensor and processing technology is planned for simplified scenarios employing both enhanced and non-cooperative targets. Further development is required to extend this basic capability to address specific applications with complex configurations. Recent work is examining a much simpler, low cost approach for short range 6DOF tracking utilizing an integrated CCD camera and solid state or semiconductor laser rangefinder.

ATC proposes a program to simulate Cargo Transfer Vehicle (CTV) AR&C operations including evaluation of critical sensor/processor parameters critical to CTV/NLS requirements.

1. The first part of the document discusses the importance of maintaining accurate records of all transactions.

2. It is essential to ensure that all entries are supported by appropriate documentation and receipts.

3. Regular audits should be conducted to verify the accuracy of the records and identify any discrepancies.

4. The second part of the document outlines the procedures for handling disputes and resolving conflicts.

5. It is important to establish clear communication channels and protocols for addressing any issues that arise.

6. The third part of the document provides a detailed overview of the financial statements and their components.

7. This section includes a breakdown of the income statement, balance sheet, and cash flow statement.

8. The fourth part of the document discusses the various factors that can impact the overall financial performance of the organization.

9. It highlights the importance of strategic planning and budgeting in achieving long-term success.

10. The fifth part of the document concludes with a summary of the key findings and recommendations.

11. It emphasizes the need for continuous monitoring and evaluation of the financial health of the organization.

12. The final part of the document provides a list of references and sources used in the analysis.

13. This section includes a list of relevant literature, reports, and other documents that informed the study.

14. The document concludes with a statement of appreciation to the individuals and organizations that provided support and assistance throughout the project.

33-18

N 93-22259
A133 ONLY
146744

1-3

A "PARC" SYSTEM FOR TERMINAL DOCKING

by

John A. Gilbert and Cheryl D. Bankston¹

A Panoramic viewing system for Automated Rendezvous and Capture (PARC) has been proposed as a visual information feedback system for terminal docking/berthing. The system relies on a unique Panoramic Annular Lens (PAL) which captures an image of its surroundings in real time.

This paper describes the evolution of the PAL along with technical details of its imaging capabilities. Several examples are given of radial metrology, where PAL imaging systems are used to perform visual inspections and measurements. Digital image acquisition and processing techniques, used to interpret various features appearing in the images and to transform images for improved human viewing, are also included. These discussions are followed by a potential application for PARC involving berthing of active and passive mechanical assemblies associated with Space Station Freedom.

The first attempt to design a system for panoramic imaging was made by Mangin in 1878.¹ Since that time, numerous devices have been patented.² These endeavors can be divided into two main groups: those in which the imaging device or a part of it is rotated around its axis to scan the area of interest, and those which utilize combinations of optical elements to obtain a single panoramic view. These optical elements may have several refracting/reflecting parts with collinear optical axes or may consist of a single block having several refracting and reflecting surfaces. Unfortunately, these compound systems are often difficult to manufacture and miniaturize if high quality panoramic images are needed. Scanning techniques^{3,4} also have disadvantages; beside the need for a rotating mechanism, no simultaneous viewing of the entire space is possible. These constraints severely limit functional and real-time capabilities. Fortunately, many of the drawbacks of both compound and scanning systems were eliminated in the development of the panoramic annular lens (PAL).⁵

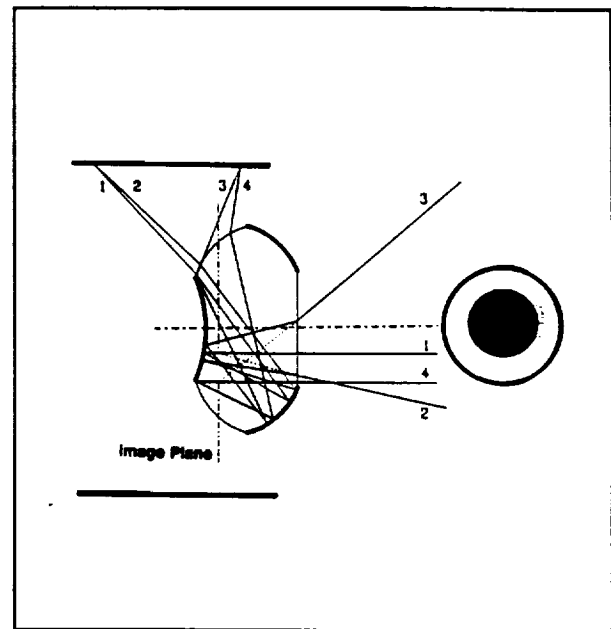

Figure 1. A ray diagram of the PAL.

The PAL is a single element lens, with spherical surfaces, which collects light for imaging and then forms an internal virtual image of its surroundings. Figure 1 shows some rays traced through the PAL, and the location of the virtual image. Since the annular image is formed within the PAL itself, it must be transferred to an image capturing device using a collector lens. Figure 2 shows that the field of view for a typical PAL extends from 20° below the horizon to 25° above the horizon, 360° around. Figure 3 shows an image taken with the PAL to demonstrate its unique characteristics.

¹ John is a professor of Mechanical Engineering and director of the Holography, Applied Mechanics, and Photonics Laboratories at the University of Alabama in Huntsville, Huntsville, Alabama 35899. He also serves as president of Optechonology, Inc., Gurley, Alabama, 35748. Cheryl is a research assistant in the College of Engineering at the University of Alabama in Huntsville, Huntsville, Alabama 35899.

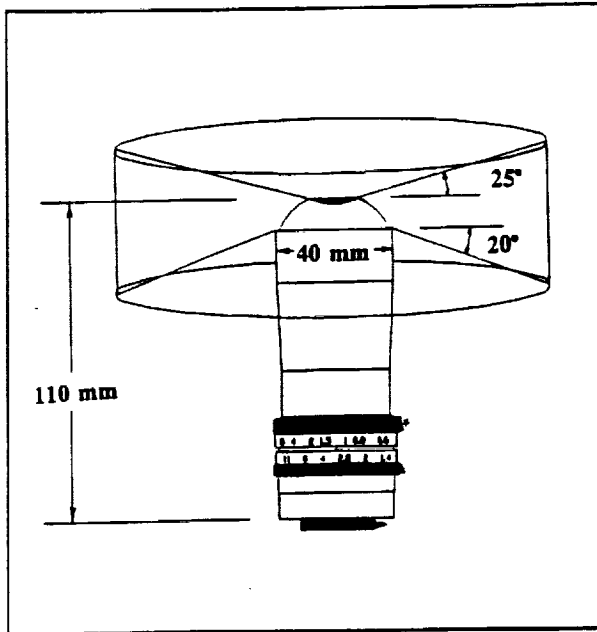

Figure 2. A PAL imaging system. Figure provided courtesy of Optechnology, Inc.



Figure 3. An image of the Alabama Space and Rocket Center taken with a PAL camera.

Various tests and experiments have been performed to illustrate that the PAL can be used as a profilometer,^{6,7} for panoramic imaging and visual inspection;⁸⁻¹⁰ and, in conjunction with speckle,^{11,12} moire,¹³ and holographic^{14,15} measurement techniques. Computer algorithms for linearizing the annular images have also been developed.¹⁰

These studies form the basis for a PARC system which is being considered for applications involving terminal berthing/docking associated with Space Station Freedom, and other space-based operations connected with the Space Exploration Initiative.

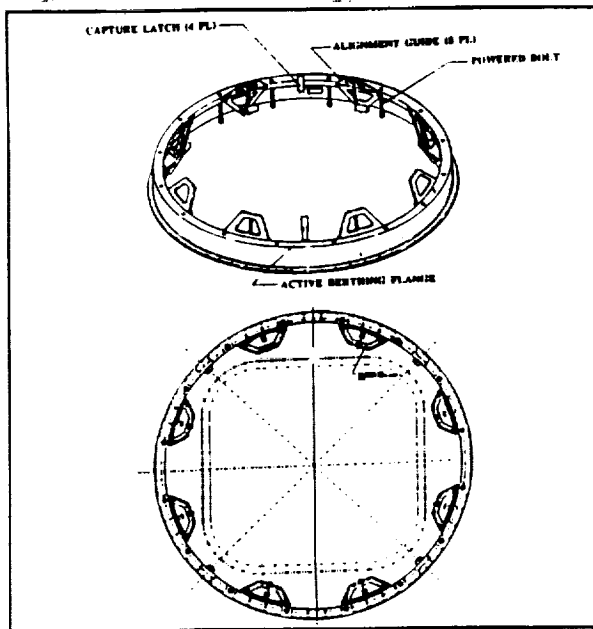

Figure 4. Active berthing assembly showing alignment guides (petals), latches, and berthing flanges.

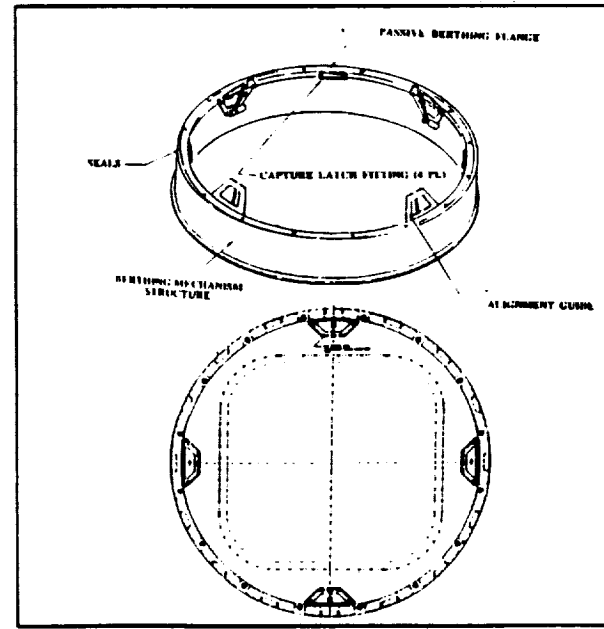

Figure 5. Passive berthing assembly showing alignment guides (petals), latches, and berthing flanges.

Figures 4 and 5, for example, show the current designs proposed for active and passive berthing mechanisms on space station. The petals on the assemblies are used as alignment guides; a critical need exists to sense the relative positions of the petals with respect to the flanges in order to facilitate berthing and to ensure that the modules are sealed properly. A multi-camera system can be used to monitor this operation; however, placement of the hardware and synchronization of the images pose significant problems.

An alternate approach has been proposed to the Marshall Space Flight Center in which a PARC imaging system is mounted on the hatch of an active module. Plans call for mounting the PAL adjacent to the viewing window and capturing images using a CCD camera. Near term feasibility tests include a 6-degree of freedom simulation with hardware in the loop.

References

1. Mangin, F., French Pat. 1:5.374, 1878.
2. Hill, R., Brit. Pat. 225.398, 1924; Schultz, H., DRP 620.538, 1935; Merle, A., DRP 672.393, 1939; Buchelle, D.R., US Pat. 2.638.033, 1950; Majoros, S., Hung. Pat. 143.538, 1954; Brachvogel, H., PRD Pat. 1.135.677, 1960; Bargavist, N., US Pat. 3.984.178, 1976; Wolf, R., Gebrauchsmuster BRD 7.819.433, 1978; Merke, W., Richter, R., von Rohr, M., Das Photographische Objektiv, Edward Brothers Inc., Ann Arbor 1948; Oharek, F., "Annular projection lens for 360° nonprogrammed visual display," in the Report of SORL Space Optics Research Lab, Chelmsford, Massachusetts 1982.
3. Rees 20 Subminiature CCTV Camera System, Rees Instruments Ltd., Old Woking, England.
4. Downhole TV Camera TT 300, Terratest, Lausanne, Switzerland.
5. Greguss, P., U.S. Patent No. 4,566,763, 1984.
6. Gilbert, J.A., Greguss, P., Lehner, D.L., Lindner, J.L., "Radial profilometry," Proc. of the Joint BSSM/SEM International Conference on Advanced Strain Measurement Techniques, London, England, August 24-27, 1987, Whittles Publishing, pp. 97-107.
7. Greguss, P., Gilbert, J.A., Matthys, D.R., Lehner, D.L., "Developments in radial metrology," Proc. of SPIE International Symposium on Optical Engineering and Industrial Sensing for Advanced Manufacturing Technologies, Vol. 954, Dearborn, Michigan, June 25-30, 1988, pp. 392-398.
8. Gilbert, J.A., Matthys, D.R., Greguss, P., "Optical measurements through panoramic imaging systems," Proc. of the 1990 Int. Conf. on Hologram Interferometry & Speckle Metrology, Baltimore, Maryland, November 4-7, 1990, pp. 164-171.
9. Gilbert, J.A., Matthys, D.R., Lehner, D.L., Hendren, C.M., "Panoramic imaging systems for nondestructive evaluation," Proc. of the Third Conference on Nondestructive Evaluation for Aerospace Requirements, Huntsville, Alabama, June 4-6, 1991.
10. Matthys, D.R., Gilbert, J.A., Puliparambil, J., "Endoscopic inspection using a panoramic annular lens," Proc. of SPIE's 1991 International Symposium on Optical & Optoelectronic Applied Science & Engineering, San Diego, California, July 21-26, 1991.
11. Matthys, D.R., Greguss, P., Gilbert, J.A., Lehner, D.L., Kransteuber, A.S., "Radial metrology with a panoramic annular lens," Proc. of SPIE's 33rd. Annual International Symposium on Optical & Optoelectronic Applied Science & Engineering, San Diego, California, August 6-11, 1989.
12. Gilbert, J.A., Greguss, P., Matthys, D.R., Lehner, D.L., "Recent developments in radial metrology: a computer-based optical method for profiling cavities," Proc. of Optika '88, Third Int. Symp. on Modern Optics, Volume II, Budapest, Hungary, September 13-16, 1988, pp. 413-418.
13. Gilbert, J.A., Matthys, D.R., Lehner, D.L., "Moire measurements using a panoramic annular lens," Proc. of SPIE's 1991 International Symposium on Optical & Optoelectronic Applied Science & Engineering, San Diego, California, July 21-26, 1991.
14. Gilbert, J.A., Greguss, P., Kransteuber, A.S., "Holo-interferometric patterns recorded through a panoramic annular lens," Proc. of SPIE's International UNESCO Seminar on 3-D Holography, Volume 1238, entitled 3-D Holography '89, Kiev, USSR, September 5-8, 1989.
15. Gilbert, J.A., Matthys, D.R., Hendren, C.M., "Displacement analysis of the interior walls of a pipe using panoramic holo-interferometry," Proc. of SPIE's 1991 International Symposium on Optical & Optoelectronic Applied Science & Engineering, San Diego, California, July 21-26, 1991.

1. The first part of the document discusses the importance of maintaining accurate records of all transactions.

2. It is essential to ensure that all entries are supported by appropriate documentation and receipts.

3. Regular audits should be conducted to verify the accuracy of the records and to identify any discrepancies.

4. The second part of the document outlines the procedures for handling cash and other assets.

5. All cash receipts should be recorded immediately and deposited in a secure bank account.

6. Disbursements should be made only for authorized purposes and supported by proper vouchers.

7. The third part of the document describes the methods for calculating and reporting financial results.

8. Financial statements should be prepared on a regular basis and reviewed by management.

9. The fourth part of the document provides information on the legal requirements for record-keeping.

10. It is important to comply with all applicable laws and regulations regarding financial reporting.

11. The fifth part of the document discusses the role of internal controls in preventing fraud and errors.

12. Strong internal controls are necessary to ensure the integrity and reliability of the financial data.

13. The sixth part of the document concludes with a summary of the key points and a call to action.

14. It is the responsibility of all staff to adhere to these guidelines and maintain the highest standards of accuracy.

DESIGN AND FABRICATION OF AN AUTONOMOUS RENDEZVOUS AND DOCKING SENSOR USING OFF-THE-SHELF HARDWARE

Dr. Gary E. Grimm



Applied Technology Division
1 Space Park Bldg. R1/2054
Redondo Beach, CA 90278
(213)812-9639 Phone
(213)812-0109 FAX

Thomas C. Bryan
Richard T. Howard
Michael L. Book
NASA
MSFC EB24
Huntsville, AL 35812
(205)544-3550 Phone
(205)544-3801 FAX

N 9 3 5 2 2 2 6 0

ABS. ONLY

146746

P. 3

Statement of technical details of the capability being described

NASA Marshall Space Flight Center (MSFC) has developed and tested an engineering model of an automated rendezvous and docking sensor system composed of a video camera ringed with laser diodes at two wavelengths and a standard remote manipulator system target that has been modified with retro-reflective tape and 830 and 780 nm optical filters. TRW has provided additional engineering analysis, design, and manufacturing support, resulting in a robust, low cost, automated rendezvous and docking sensor design. We have addressed the issue of space qualification using off-the-shelf hardware components. We have also addressed the performance problems of increased signal to noise ratio, increased range, increased frame rate, graceful degradation through component redundancy, and improved range calibration.

Next year, we will build a breadboard of this sensor. The phenomenology of the background scene of a target vehicle as viewed against earth and space backgrounds under various lighting conditions will be simulated using the TRW Dynamic Scene Generator Facility (DSGF). Solar illumination angles of the target vehicle and candidate docking target ranging from eclipse to full sun will be explored. The sensor will be transportable for testing at the MSFC Flight Robotics Laboratory (EB24) using the Dynamic Overhead Telerobotic Simulator (DOTS).

History of the origins and evolution of the capability

As stated earlier, the TRW design evolved from an existing NASA design developed at MSFC EB24. This design was modified to further improve performance and to support manufacture, verification, and space qualification.

TRW has a long history in the design and fabrication of space qualified sensors, guidance, acquisition, and tracking systems for military and non-military applications as the following table indicates.

Program	Item	Comments
OMV	Rendezvous & berthing sensor & operations	Proposal
GEODSS	Visible cameras & space object tracking hardware & software	Part of nation tracking network
VUE	Commercial visible CCD, tracking hardware & software	Space qualified & flown
DSP	IR detection & tracking sensor hardware & software	Long lived space system part of national defense network
Brilliant Pebbles	Tracking & homing sensor, optics hardware, firmware & software	Prototype built
IRAD	Space qualification of visible CCD camera	In progress
IRAD	Sensor performance simulation facility	Existing hardware & software for evaluation of active & passive sensors
IRAD	Sensor test facility	Existing hardware & software for evaluation of active & passive sensors
IRAD	Millimeter wave aircraft landing sensor	Hardware, software, & simulation completed
IRAD	6DOF simulation software & hardware upgrade & requirements definition	Existing full scale mock up docking simulation

During the OMV program TRW developed operations and sensor concepts for rendezvous and docking of space vehicles. We have built prototype hardware for Brilliant Pebbles program consisting of a miniaturized processor and sensor for use on a space based interceptor. Similar hardware and software will be used for the rendezvous docking system. On VUE, we were able to design, build, and fly a space based visible sensor for tracking space objects in 18 months by using a maximum amount of off the shelf commercial and military hardware. Several of our current IRAD efforts have direct applications to rendezvous and docking sensors.

The level of maturity of the capability

We have a specification list of minimum requirements for the automated rendezvous and docking system. We have developed an analytical model of the sensor design to verify that the system performance will meet the docking system requirements. We have a parts list for all elements of the automated rendezvous and docking sensor system. We have an optical bench on which to assemble the breadboard. Other simulation and analysis tools as well as available laboratory hardware include visible CCD cameras and a laser ranging system. The Sensor Test Facility includes a dynamic scene generator in which the effects of jitter, drift, and sensor motion on overall sensor performance can be measured and tested.

Test experience and/or experimental results

TRW has experience conducting autodocking simulations using DOTS to: 1) integrate and calibrate new algorithms, 2) characterize the autodocking components, 3) validate autodocking requirements, 4) demonstrate sensor driven autonomous docking, 5) expand the docking sensor's operational envelope, 6) test new coordinated six degree of freedom algorithms, and 7) exercise the extended translational range of the simulation facility.

Tools and methods were developed to integrate TRW's 6 degree of freedom orbit dynamics simulator with the DOTS and the engineering model of the sensor in order to perform closed loop docking runs with real sensor data. We expect to use the DOTS facility to evaluate the TRW rendezvous and docking sensor performance. Test and verification requirements were derived from similar optical sensor qualification and test requirements and build heavily on our VUE experience and our experience with the TRW Sensor Test Facility. On the VUE program, we space qualified a commercial CCD focal plane array. Producibility assessment for the automated rendezvous and docking sensor proceeds from our survey of existing space qualified sensors and our experience in space qualification of similar systems and payloads with similar components. In September of 1991, TRW successfully completed space qualification of a commercial off-the-shelf (Pulnix) CCD camera system.

Source/sponsorship and current funding estimates

This effort is being pursued on Internal Research and Development funds.

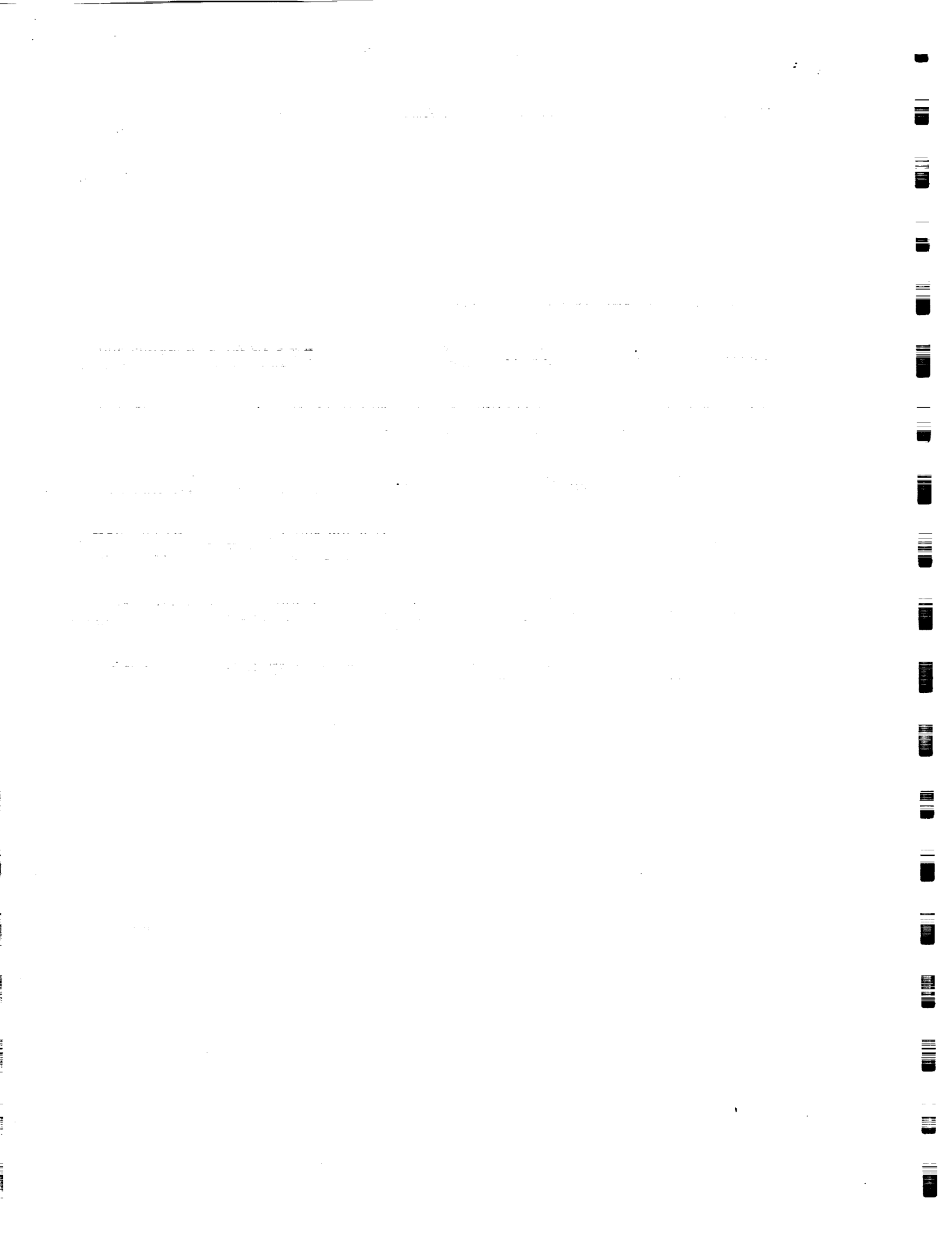

SBS-13
MSFC ONLY
N 93-22261

Virtual Reality Applications to Automated Rendezvous & Capture

P. 3

Joseph Hale, MSFC, EO23
Daniel O'Neil, MSFC PT31

Virtual Reality (VR) is a rapidly developing Human/Computer Interface (HCI) technology. The evolution of high-speed graphics processors and development of specialized anthropomorphic user interface devices, that more fully involve the human senses, have enabled VR technology. Recently, the maturity of this technology has reached a level where it can be used as a tool in a variety of applications. This paper provides an overview of: VR technology, VR activities at Marshall Space Flight Center (MSFC), applications of VR to Automated Rendezvous and Capture (AR&C), and identifies areas of VR technology that requires further development.

VR is a computer generated three-dimensional graphic environment that senses a user's behavior and updates the display of that environment accordingly. Head-mounted color monitors with wide-angle binocular optics displays the environment to the user. Changes in hand and head position and attitude are the basic user inputs sensed by a VR system. When the user moves or turns his or her head, the computer generated view shifts accordingly. With a hand gesture, the user can "fly" his/her point-of-view to another location within the virtual environment and "grab" virtual objects to move or re-orient them.

Ames Research Center (ARC) developed a prototype VR system, the Virtual Interface Environment Workstation (VIEW). It consists of a DataGlove and a Head Mounted Display (HMD). Thomas G. Zimmerman and L. Young Harvill created the DataGlove at VPL Research, Inc. Fiber optic cables, embedded in the glove, bend with the fingers and produce varying light levels, much as a bend in a water hose will decrease the flow of water [1]. The varying light levels provide the positional data for the fingers. In 1987, VPL Research extended this concept to the whole body with the DataSuit [2]. Polhemous Navigation Sciences Division of McDonnell Douglas Corporation created the sensor that tracks the position and orientation of the hand and head. Head mounted computer graphics display systems were first developed by Ivan Sutherland at MIT in 1967 [2]. Scott Fisher developed the VIEW HMD at the ARC [1]. Other ARC VR activities include the Convolvotron, a 3-D audio system. [4]

MSFC is currently developing the capability to apply VR as a tool in Human Factors analyses, hardware development, operations development,

training, and mission operations. The VR system consists of the VPL DataGlove and Eyephones, a Silicon Graphics 4D/310 VGX, and a Macintosh II computer. MSFC has developed a low fidelity virtual mockup of Space Station Freedom.

Virtual Reality has a number Automated Rendezvous and Capture (AR&C) applications. Primary applications are in the areas of system development, operations development, training, and mission operations.

During the development phase of the AR&C system, designers, reviewers, and users can "enter" the 3-D graphic models of the system. Hardware configuration concepts and designs can be evaluated in this Virtual World. Form and fit for assembly and both Orbital and Line Replaceable Unit (ORU and LRU) changeout can be tested. Haptic and tactile feedback devices will enhance these analyses by providing the user with the sense of touch. VPL and UNC have both developed this type of user interface. [1,3] This virtual mockup can also assist in the analysis of viewing, dynamic work envelopes, and restraints and mobility aids.

Operations concepts can develop concurrently with hardware design development. This ensures operations input to early hardware design, where it is most effective. A person can monitor an unpiloted Cargo Transfer Vehicle (CTV) as if he/she were on the vehicle or the target. An observer could view an AR&C task from inside or outside the activity. In "Project Grope", a molecular docking system at UNC, the team determined that "the most valuable result from using Grope III for Drug Docking is probably the radically improved situational awareness" [3].

Techniques and technologies developed during the systems and operations development phase could also be utilized during mission operations to enhance situational awareness. The Stafford committee report identified VR techniques in conjunction with robotic precursor missions. Telemetry from the remote system would allow the operator to see through the eyes of the robot, use the end effectors as if they were their own, and feel the objects that the system manipulates. A person could also rehearse an AR&C maneuver, in a real-time simulation, and record the command sequences for later uplink and execution on an autonomous AR&C mission.

Interfaced with training simulators, VR can add a new dimension to the training environment. Trainees can gain insights into how the system functions from the CTV, target, or 3rd person point-of-view. UNC reported a two-fold increase in task performance, using VR, over traditional graphic systems. [3]

More than one person can enter the same Virtual World at the same

time without necessarily being in the same physical location. For example, a designer at a remote location might call a reviewer at MSFC and say, "Put on your Eyephones, I have a design modification I want to show you." Both could then view the same design, the reviewer could watch as the designer manipulates the virtual mockup, then the designer could watch as the reviewer manipulates the object. Each participant is able to interactively control aspects of this mutual world. Operations development, remote training, and even teleconferencing can benefit from shared virtual worlds.

Key areas of VR that require further development include: 1) An ability to model and render object behavior and dynamics attributes, with greater accuracy, 2) Refinement of user interfaces that more fully incorporate the user's senses (e.g., force-reflective/tactile feedback, improved visual resolution, 3-D audio), 3) A capability to translate existing CAD databases into VR databases, and 4) Full utilization of state-of-the-art graphics engines' capabilities (e.g., illumination and reflections, textures, "realism") while, at the same time, reducing time delay and increasing frame rate. Developments in these areas should lead to VR graphic libraries, tools, standardization, commonality, and communication protocols.

This paper has demonstrated that VR is a technology that is ready to be incorporated into space systems development and operations. It has described applications of VR to AR&C projects. Also, it has identified required development efforts that would refine VR techniques and technologies to increase the fidelity of these AR&C applications.

REFERENCES

- [1] The Second Computer Revolution: Visualization. Richard Mark Fried Hoff and William Benson. Harry N. Abrams, Inc., New York, 1989
- [2] Virtual Reality. Howard Rheingold, Summit Books: 1991.
- [3] "Project Grope - Haptic Displays for Scientific Visualization", Frederick P. Brooks, Jr., Ming Ouh-Young, James Batter, and P. Jerome Kilpatrick; Dept. of Computer Science, University of North Carolina at Chapel Hill.
- [4] Convolvotron: contact: Elizabeth M. Wenzel, NASA ARC MS 262-2, Moffet Field CA. 94035

1. The first part of the document discusses the importance of maintaining accurate records of all transactions.

2. It is essential to ensure that all data is entered correctly and consistently across all systems.

3. Regular audits should be conducted to verify the accuracy and integrity of the information.

4. The second section outlines the various methods used to collect and analyze data, including surveys and interviews.

5. These methods are designed to gather comprehensive information about the subjects being studied.

6. The results of these analyses are then used to identify trends and patterns in the data.

7. This process is critical for making informed decisions and developing effective strategies.

8. The final part of the document provides a summary of the findings and offers recommendations for future research.

9. It is hoped that these insights will be valuable to other researchers in the field.

10. The document concludes with a statement of appreciation to the participants and funding agencies.

11. The authors express their gratitude for the support and assistance provided throughout the project.

12. This work was made possible through the generous contributions of the following organizations.

13. The authors would like to thank the reviewers for their constructive feedback and suggestions.

14. Their comments have greatly improved the quality and clarity of this document.

15. Finally, the authors wish to thank their families and friends for their unwavering support and encouragement.

Use of Non-spherical Gravity Harmonics for Relative Motion GN&C. (Category 2)

David M. Henderson
TRW Houston
Phone: 713-333-3133
FAX 713-333-1875

536-18
ABS: ONLY
N 93-22262
146747
p. 2

Abstract:

Detailed analysis of the Automatic Rendezvous and Capture problem indicate a need for three different regions of mathematical description for the GN&C algorithms: (1) multi-vehicle orbital mechanics to the rendezvous interface point, i.e. within 100 nm, (2) relative motion solutions (such as Clohessy-Wiltshire type) from the far-field to the near-field interface, i.e. within 1 nm and (3) close proximity motion - the near-field motion where the relative differences in the gravitational and orbit inertial accelerations can be neglected from the equations of motion. Limit boundaries to these regions can be precisely defined by further analysis and will be functions of the tracking measurement accuracies and the computer resources available for the solution of the algorithms.

This paper analyzes the relative motion in Regions 2 and 3 above and presents the derivation and discussion of the general case of non-spherical gravitational perturbed relative motion. Mathematical deviations from the numerically integrated spherical gravity case and solutions from the Clohessy-Wiltshire equations are presented in the analysis. Based upon this preliminary analysis, it is recommended that further efforts be used to assess the relative position and velocity differences in Region 2 due to non-spherical gravity harmonics and that viable GN&C algorithms be developed to

include these gravity perturbations (especially the effects of the first gravity harmonic, J₂).

Future GN&C systems for the AR&C using relative motion sensor measurements from either an onboard laser tracking system or the GPS will be able to detect these perturbations in the relative motion. Commensurate with the accuracy of these sensor measurements, the GN&C algorithms must also be able to predict the relative motion using the gravity perturbations due to the non-spherical gravity harmonics. Increases in RCS performance (by using less rocket propellant) during AR&C operations can also be expected by the use of these more accurate GN&C systems.

Current Status:

Supporting engineering analysis proof-of-concept programs have been developed and are resident on the CRAY XMP computer system at JSC/NASA. These engineering analysis programs and concepts are described in the document, "Reference Equations of Motion for Automatic Rendezvous and Capture," by David Henderson, NASA/JSC Internal Note, to be published in October 1991.

Source / Sponsorship:

This work is under development by TRW Houston under contract to NASA/JSC Navigation, Control and Aeronautics Division.

GN&C Translation and Rotation Control Parameters for AR&C (Category 2).

David M. Henderson
TRW Houston
Phone: 713-333-3133,
FAX 713-333-1875

537-18
N 93 222263

146748

A-1

Abstract:

Detailed analysis of the Automatic Rendezvous and Capture problem indicate a need for three different regions of mathematical description for the GN&C algorithms: (1) multi-vehicle orbital mechanics to the rendezvous interface point, i.e. within 100 nm, (2) relative motion solutions (such as Clohessy-Wiltshire type) from the far-field to the near-field interface, i.e. within 1 nm and (3) close proximity motion, the nearfield motion where the relative differences in the gravitational and orbit inertial accelerations can be neglected from the equations of motion.

This paper defines the reference coordinate frames and control parameters necessary to model the relative motion and attitude of spacecraft in the close proximity of another space system (Regions 2 and 3) during the Automatic Rendezvous and Capture phase of an orbit operation.

The relative docking port target position vector and the attitude control matrix are defined based upon an arbitrary spacecraft design. These translation and rotation control parameters could be used to drive the error signals in the guidance system for control inputs to the vehicle flight control systems.

Measurements for these control parameters would become the basis for an autopilot or FCS design for a specific spacecraft.

The docking port relative position and velocity target vectors as outlined in this work couples the effects of the translation and rotation control activity. Based on analysis of these preliminary control parameters, it is recommended that guidance and control systems functions couple translation and attitude control in Region 3 for safe docking maneuvers. In Region 2, the relative range between the docking port targets is large enough so that translation and rotation guidance and control functions can be independent of one another.

Current Status:

Supporting engineering analysis proof-of-concept programs have been developed and are resident on the CRAY XMP computer system at JSC/NASA. These engineering analysis programs and concepts are outlined in the document, "Reference Equations of Motion for Automatic Rendezvous and Capture," by David Henderson, JSC/NASA Internal Note, to be issued in October 1991.

Source / Sponsorship:

This work is under development by TRW Houston under contract to NASA/JSC Navigation, Control and Aeronautics Division.

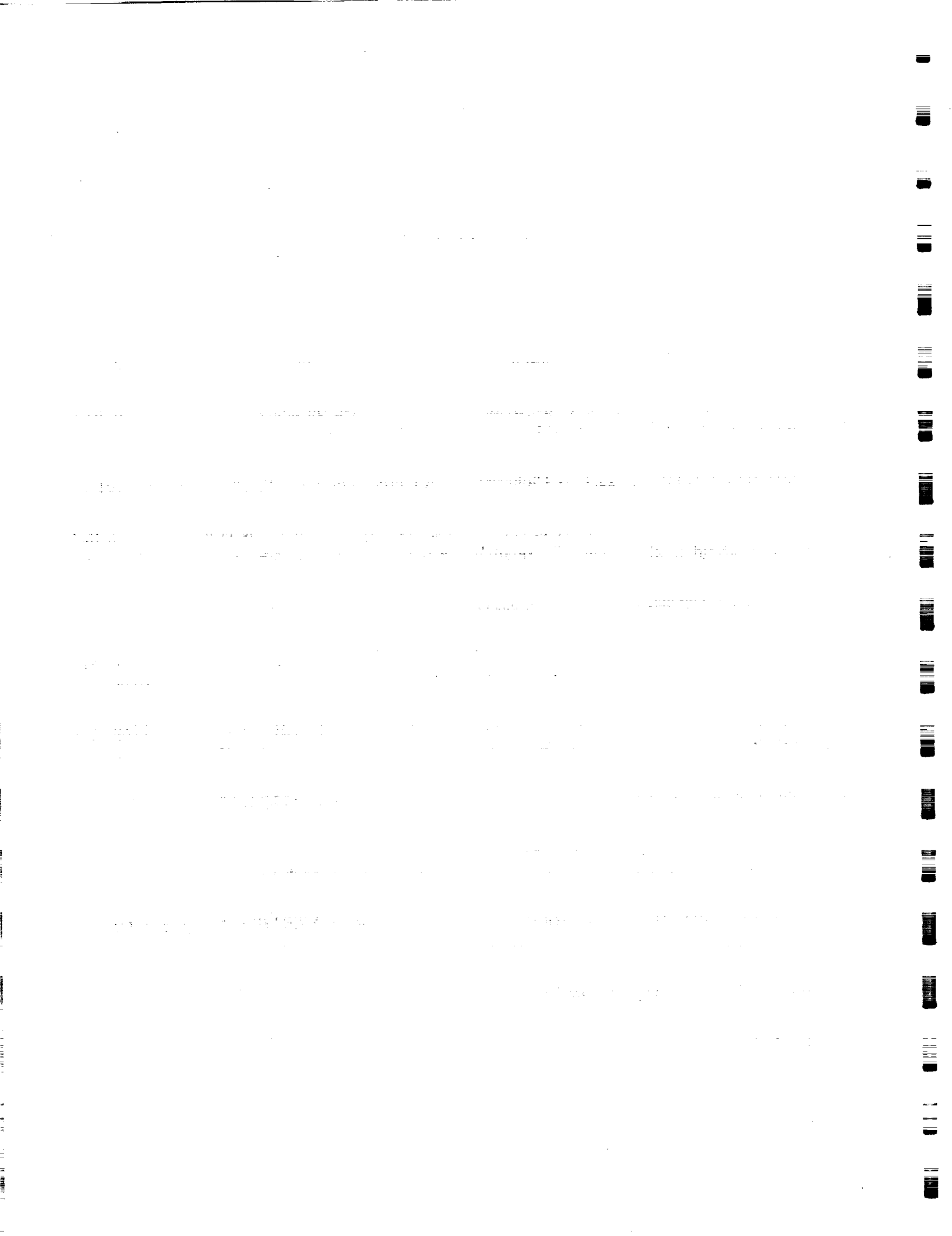

ABSTRACT

33-61
ABS. ONLY
N 93 - 22264

TITLE: RESULTS OF PROTOTYPE SOFTWARE DEVELOPMENT FOR
AUTOMATION OF SHUTTLE PROXIMITY OPERATIONS P. 2

AUTHORS' NAMES:

H. K. HIERS; NASA JSC/ER2; Phone:713-483-2036; FAX:713-483-3204; E-Mail ID:HIERS_HARRY@A1@CTSD2 (All-in-One)

O. W. OLSZEWSKI; LESC/C19; Phone:713-333-6218; FAX:713-333-7201; E-Mail ID:OLSZEWSKI@LOCK.JSC.NASA.GOV (All-in-One)

TECHNICAL DESCRIPTION:

A Rendezvous Expert System (REX) was implemented on a Symbolics 3650 processor and integrated with the 6 DOF, high fidelity Systems Engineering Simulator (SES) at the NASA Johnson Space Center in Houston, Texas. The project goals were to automate the terminal phase of a shuttle rendezvous, normally flown manually by the crew, and proceed automatically to docking with the Space Station Freedom (SSF). The project goals were successfully demonstrated to various flight crew members, managers, and engineers in the technical community at JSC. The project was funded by NASA's Office of Space Flight, Advanced Program Development Division.

Because of the complexity of the task, the REX development was divided into two distinct efforts. One to handle the guidance and control function using perfect navigation data, and another to provide the required visuals for the system management functions needed to give visibility to the crew members of the progress being made towards docking the shuttle with the LVLH stabilized SSF.

The Clohessy-Wiltshire targeting equations for relative motion were selected as the basic formulation for the guidance function. With minor modifications, the same CW algorithm was found to be sufficiently accurate not only to do standard Prox Ops targeting, but final approach, docking and even station keeping during the final approach.

Typical errors noted during the Vbar and Rbar approaches through docking with both shuttle Digital Autopilots will be reviewed. Results of off-line testing of the REX guidance algorithm with 100 worst case nav error IC vectors will be discussed, as well as modifications made to the CW guidance to allow straight line Line-of-Sight (LOS) final approaches like Vbar, Rbar, and TEA (torque equilibrium angle) to SSF.

To simplify the mode of operations with the shuttle GNC, REX was designed to operate in the minimum impulse mode with both the standard and latest alternate shuttle Digital Autopilot (DAP). REX was also capable of operation in Monitor and Automatic modes. In the Monitor mode, REX would only recommend pulses for manual crew execution via the translation hand controller (THC). In the Automatic mode, it would send the recommended pulses to the shuttle DAP for execution. The crew could take over control of the shuttle at any time by placing REX in the Monitor mode or turning off the guidance by pushbutton entries.

The rationale for breaking the proximity operations phase into the following four sub-phases will be discussed:

- a. Insure Line-of-Approach (LOA) crossing, where LOA is Vbar (or Rbar)
- b. LOA Capture
- c. Vbar or Rbar final approach or stationkeeping
- d. Docking

A discussion of how the shuttle systems were managed and the overall operations monitored will be conducted. The various trajectory and systems displays designed and implemented in REX will be discussed. These include real time plots of in-plane and out-of-plane relative motion; display of nav sensor data; display and selection of the guidance features; and plots of RCS propellant consumed and plume impingement loads on SSF as compared with previous simulation results by flight crews.

Other crew aids to be discussed include a pictorial display of the translation hand controller (THC) recommended pulses (backed up by a speech synthesizer), trajectory predictor icons that would indicate where the shuttle would be 5 and 10 minutes later (for collision avoidance and risk assessment), delta V pulse predictors to help crews in trajectory shaping, target icons drawn over a COAS representation for navigation error assessment, nav sensor health and status, and automated checker of crew procedures.

A feature added as the project matured was the RCS fuel saver. This feature checked the nav error, and if time to docking was sufficiently far in the future, would allow the errors to be corrected slowly and fuel used more efficiently. However, if time to docking was imminent, the fuel saver feature was automatically disabled and lateral errors reduced quickly in preparation for docking. A discussion of its operation and implementation will be conducted.

In regards to capture, the similarities and differences, from a guidance point of view, between docking and berthing after a final approach will be discussed.

SOVIET AUTOMATED RENDEZVOUS AND DOCKING SYSTEM OVERVIEW

Elaine M. Hinman and David M. Bushman
NASA Marshall Space Flight Center

P. 4

The Soviets have been performing automated rendezvous and docking for many years. This paper will present an overview and brief history of the Soviet AR&D system, based on the open literature and publicly available sources.

The unmanned Progress resupply ships regularly dock with the current Mir space station. Analysts believe that the earliest docking attempts by the Soviets were made in 1967 with the Soyuz 1 and 2 crafts. Soyuz 1 developed stabilization problems so the docking attempt had to be cancelled. The first successful Soviet docking between two unmanned vehicles was in late October of 1967 when Cosmos 186 and 188 docked in orbit.

Soyuz 3 (manned) maneuvered to within 200 meters of the unmanned Soyuz 2 in October of 1968. Soyuz 4 and 5, both manned, docked and two cosmonauts transferred from Soyuz 5 to 4 via EVA. This represented the first Soviet manned docking. In the US space program, Gemini 8 docked to an Agena target vehicle in March of 1966.

In 1971, an unspecified AR&D system was used to bring the Soyuz 10 spacecraft to within 180 meters of the Salyut 1 space station. A cosmonaut then took over and completed the dock. Several missions were flown in 1973 and 1974 to prepare for the Apollo-Soyuz Test Project flight in July of 1975. For the initial docking, the Apollo acted as the active spacecraft. Later in the mission, the two spacecraft separated and docked again with the Soyuz as the active craft.

A Cosmos 772 (an unmanned Soyuz craft) autodocked to the Salyut 4 space station in September 1975 in order to validate AR&D for future unmanned flights, such as the Progress resupply modules. The first Progress resupply ship docked and transferred fuel to the Salyut 6 in January of 1978.

During the course of the Soviet space program, the autodocking system has evolved. The earlier IGLA system has been replaced with the current KURS system. Both systems are radar-based. The variation in strength between antennas is used for computing relative positions. The active spacecraft has a transponder. From discussions with Soviet engineers, it seems the docking process can be controlled either from the ground or the active (docking) spacecraft's onboard computer.

The chase vehicle flies a constant bearing approach to the target, maintaining a "guidance plane" between the two vehicles. The IGLA system required that a line-of-sight (los) be maintained between the docking faces of the two vehicles. The KURS system,

however, does not require los between the two vehicles during closure. The attached diagrams indicate a potential docking trajectories using the IGLA and KURS systems. As can be seen, more fuel can be consumed due to the spacecraft "chasing" the docking port of the MIR.

The docking requires two to three burns to adjust the trajectory. The first is at about 97 km from the station. The approaching spacecraft flies a ballistic trajectory to a point 1.5 km from the Mir. If during the trajectory there is a loss of the main radar system, the onboard computer switches to the secondary (redundant) radar system and continues the docking process.

Approximately 100 parameters are checked (once per second) by the onboard computer to insure the craft's systems are working correctly. If any one of these parameters becomes out of range, the docking is aborted. The spacecraft is removed back out to about 100 km and the docking is re-attempted. This involves a delay of about 2 days. Any decision to increase tolerances for a particular parameter is made by the ground control center engineers. This has been done in a few instances. The orbital docking position is chosen based on several factors including the position of at-sea control ships, and the position of the sun so that docking can be performed while not in the Earth's shadow.

Roll damping of the approaching spacecraft is performed between 5000 and 200 m relative distance. From 1.5 km to 200 m from the target vehicle, one slowing maneuver and angular stabilization are performed. The KURS system is active until just at contact, at which point the engines are used to "push" the spacecraft together. During the last 10 meters of closing between the chase and target vehicles, the relative velocity is about 0.2 m/s. Some parameters at contact between the Mir and an approaching spacecraft are an approach velocity of 0.1 to 0.3 m/s, lateral velocity less than 0.1 m/s with a lateral misalignment of 0.15 to 0.3 m. The angular velocity in roll is kept below 0.7 deg/s, and in pitch and yaw (summed) less than 0.6 deg/s. These numbers are based on documentation of contact between the Mir and a Kvant spacecraft.

Despite the regular autodockings of the unmanned Progress ships with the Mir and Salyut space stations, autodockings of manned vehicles with the stations have not been overly successful. The Soyuz T spacecraft was designed for full AR&D, however the autodock system has been routinely overridden in order to perform manual docking. Computer data overloads, loss of radar signal and antennae failures have been cited as reasons for failure of the AR&D system.

It is likely that the Soyuz T spacecraft incorporated the IGLA system, and the later Soyuz TM and Progress M series craft incorporated the KURS. The Mir has both systems installed. The first Soyuz TM dock occurred in May of 1986, while the first Progress M docked in September of 1989.

POTENTIAL TRAJECTORIES

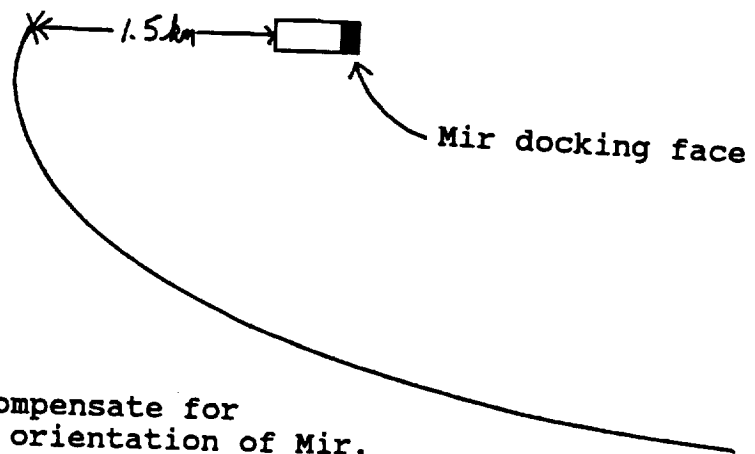
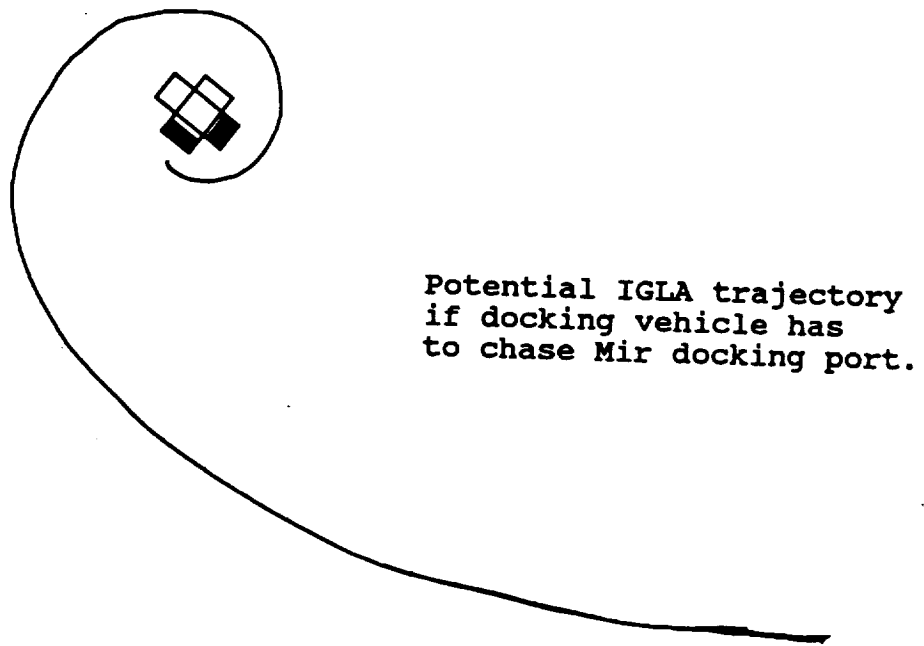

REFERENCES

Soviet Manned Orbital Stations class notes. E. Crawley (MIT Professor in charge), V. Karrask, N. Anfimov, T. Tsurikov, S. Shaevich, S. Rummyantsov, MIT July 1991.

Automated Rendezvous Techniques -- Soyuz Operations, G. Avvento, Master's Thesis, University of Houston, 1986.

Soviet Space Programs: 1981-87 Piloted Space Activities, Launch Vehicles, Launch Sites, and Tracking Support, E. Hollings, Chairman, Committee on Commerce, Science, and Transportation--US Senate, May 1988.

Spacelog 1957-1987, Volume 23, Editor T. Thompson, TRW

The Soviet Manned Space Program, P. Clark, 1988.

N 93 - 222663
NAS 074
146751
P. 3

Abstract for NASA

On-orbit Demonstration of Automated Closure and Capture Using ESA-Developed Proximity Operations Technologies and an Existing, Servicable NASA Explorer Platform Spacecraft

Bill Hohwiesner, Fairchild Space (301) 353-8924 [fax: (301) 353-1343]
Bernard Claudinon, Matra Marconi Space 011- 33-6139-6064

Statement of the Technical Details

The European Space Agency (ESA) has been working to develop an autonomous rendezvous and docking capability since 1984 to enable Hermes to automatically dock with Columbus. As a result, ESA with Matra, MBB, and other Space Companies have developed technologies that are also directly supportive of the current NASA initiative for Automated Rendezvous and Capture. Fairchild and Matra would like to discuss the results of the applicable ESA/Matra rendezvous and capture developments, and suggest how these capabilities could be used, together with an existing NASA Explorer Platform satellite, to minimize new development and accomplish a cost effective automatic closure and capture demonstration program.

Several RV sensors have been developed at breadboard level for the Hermes/Columbus program by Matra, MBB, and SAAB. For example, the Matra laser proximity operation sensor, developed with Matra and CNES funding is based upon a flight qualified CCD sensor working together with a pulsed laser to illuminate retroreflectors mounted on the target docking side. The CCD operates in a Flash-During-Transfer(FDT) mode, enabling operation even with sunlight in the sensor FOV. The sensor has demonstrated good results at ranges out to 1 Km and at proximity operation relative velocities, even with the sun in the FOV. The sensor recently demonstrated the following at 10 m: range accuracy to .35% of range (3 sigma); elevation/azimuth accuracy better than 0.01° (3 sigma); and attitude angles of the target to better than 0.15° (3 sigma) using five optical retroreflectors in a 15 cm wide pattern.

Detailed algorithms for automatic rendezvous, closure, and capture have been developed by ESA and CNES for application with Hermes to Columbus rendezvous and docking, and they currently are being verified with closed-loop software simulation. The algorithms have multiple closed-loop control modes and phases starting at long range using GPS navigation. Differential navigation is used for coast/continuous thrust homing, holdpoint acquisition, V - bar hopping, and station point acquisition. The proximity operation sensor is used for final closure and capture. A subset of these algorithms, comprising the proximity operations algorithms, could easily be extracted and tailored to a limited objective closure and capture flight demonstration.

The software to implement the automatic operations has been written in C, and closed loop performance tests are currently in progress. These tests include the software for final approach operations (100m to a few cm), and testing is to be complete by November 1991.

Potential Cooperative Flight Demonstration

Fairchild and Matra suggest that by combining ESA and NASA resources, a complimentary, cost effective flight demonstration program to demonstrate Automated Closure and Capture could readily be structured. This joint, cooperative program would use the automated guidance and proximity operations system developed by Matra for ESA and the existing Explorer Platform (EP) developed by Fairchild for NASA. These two system elements would be integrated by Fairchild with an EP-mounted docking module receiver and a maneuvering payload module (PLM) to close with and dock to the EP receiver.

The proposed program would have Fairchild build the docking module that would be attached on-orbit to the EP (figure 1); build the Payload Module with a maneuvering capability (figure 2) that performs the docking with the the EP-attached docking module, using the Fairchild developed Resupply Interface Mechanism (RIM, figure 3); complete development of the STS procedures for on-orbit EP payload changeout to remove the current EUVE payload and attach the docking module; and accomplish the overall system integration. ESA/Matra would provide the proximity operations sensor; the guidance software; and verify the satisfactory flight hardware closure and capture on the European Proximity Operations (EPOS) simulator and/or on the CNES 6 degree-of-freedom (DOF) Dynamic Docking Test Facility (DDTF) (figure 4). The EPOS simulator allows simulation of final approach (from 25m) with a realistic lighting environment and with large angular and position errors. The DDTF allows simulation of final approach (from 7m) and the subsequent docking dynamics with full representativity in 6 DOF. The test facility is capable of velocities up to 10 cm/sec and contact forces up to 2000 N. This testing would verify the compatibility between the GNC accuracy and the RIM docking interface, enable final tailoring of the software, and verify in real-time the system performance. Final validation of closure and capture would be done at MSFC.

Once in orbit the Shuttle crew would (1) use the RMS to change out the EP payload, removing the EUVE payload from EP and mounting the docking module to EP; (2) use the RMS to release the PLM, at 1000 ±100 meters in trail from the EP and co-altitude ±100 meters; and then (3) supervise the automatic

closure and docking to EP. From 1000 meters the closure and docking is the same whether injected by ELV or carried to orbit by the STS. For subsequent missions following injection, the PLM maneuvers to rendezvous with EP (1000± 100 meters in trail and co-altitude ±100 meters) using GPS positioning (receiver on each of EP and PLM) to provide guidance information to the rendezvous algorithms developed by ESA and Matra.

From 1000 m the laser proximity operation sensor acquires EP and provides guidance to the PLM to enable approach to the 100 meter point. From 100 meters in to contact, the proximity sensor provides the continuous positioning required by the payload guidance system to maintain position on target boresight (\bar{v}) and to control closure velocity to effect a soft (.5 cm/sec) docking.

The program makes maximum use of existing resources within both NASA and ESA, with NASA providing the EP, the docking module and payload module, and the STS launch. ESA would provide the laser sensor, the proximity operating algorithms and software, and support docking system integration on the DDTF.

The benefits of the program would be to (1) validate an automatic rendezvous and capture capability and (2) establish payload module compatibility and use with the existing Explorer Platform (EP) spacecraft. Following the demonstration mission, payload modules would be capable of automatically rendezvousing and docking with the Explorer Platform, following orbit injection by either a Taurus-class ELV or the Shuttle. Spent payload modules would automatically detach from the Explorer Platform and either de-orbit or, if retrieval was desired, adjust their orbit to rendezvous with the Shuttle to be retrieved by the Shuttle RMS.

The docking module (figure 1) is a module, similar to the existing EP Platform Equipment Deck module, that attaches the RIM active interface (docking device, figure 3)) and supporting subsystems to the EP, which becomes the passive, stationary target for the maneuvering payload module.

The payload module (figure 2) is a new development using existing technology to house the laser proximity sensor, power, attitude control, and propulsion subsystems and the RIM passive interface. Subsystems are at Table 1.

Structure	Honeycomb outer shell with internal thrust tube
Power	NiCd Battery Body-mounted Solar Array
Attitude Control	Three axis RIGA Fine Sun Sensor Magnetometer
Propulsion	Hydrazine
Navigation	GPS receiver
Command & Data	FS386 (NASA RPP derivative)
Communications	5 Kbps transceiver
Thermal	
Harness	
RIM - Passive	

Table 1 Payload Module Subsystems

Historical Statement on the Origins and Evolution of the Capability

The Explorer Platform spacecraft, built by Fairchild Space, is a derivative of the NASA Multimission Modular Spacecraft. EP has been designed for on-orbit payload changeout, and the first launch is scheduled for December 1991 with the Extreme Ultraviolet Explorer payload. The EUVE Payload, until this summer, was to have been replaced on-orbit in 1994 with the XTE Payload. Historical data from previous MMS flights shows that EP can be expected to last at least nine years with .71 probability. At present, XTE is to fly on a dedicated spacecraft, which permits EP to be used for other missions.

Development of STS on-orbit changeout procedures was accomplished by Fairchild under contract to NASA for the Solar Max repair mission. Fairchild has been under contract to NASA to develop the STS change-out procedures for the current Explorer Platform for the EUVE-XTE changeout mission. These procedures are nearly identical to those that would be required to put a docking module, instead of XTE, onto EP.

The satellite Resupply Interface Mechanism (RIM) (figure 3) was built by Fairchild to provide a means of connecting a satellite tanker to the satellite. It provided for the simultaneous mating of multiple connectors and couplers, and was designed to accept misalignments of up to ±2 inches laterally, and ±10° axially. The RIM was demonstrated in 1989 for NASA at JSC to evaluate mating, demating, interface operation and to demonstrate several RMS berthing modes. A small amount of additional development is required to streamline / miniaturize the latching mechanisms.

Source / Sponsorship and current funding estimates

We recommend that NASA and ESA allocate funding to the program as follows

NASA responsibility:

- Explorer Platform
- Docking Module design, development, and test:
- Payload Module design, development, and test:
- Program Management & Systems Engineering
- STS launch and orbit operations

ESA responsibility:

- Laser proximity operations sensor (s)
- Algorithm tailoring for demonstration mission
- Guidance software
- Verification of hardware on EPOS and/or DDTF

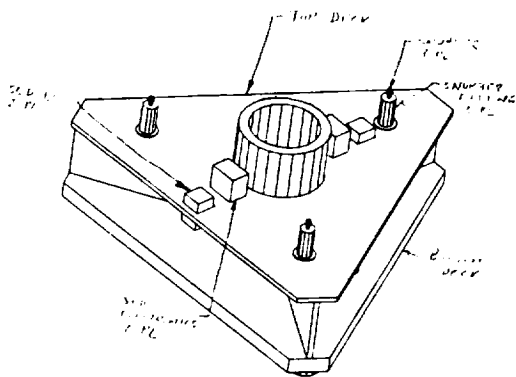

Figure 1 EP-attached Docking Module with RIM Active Interface

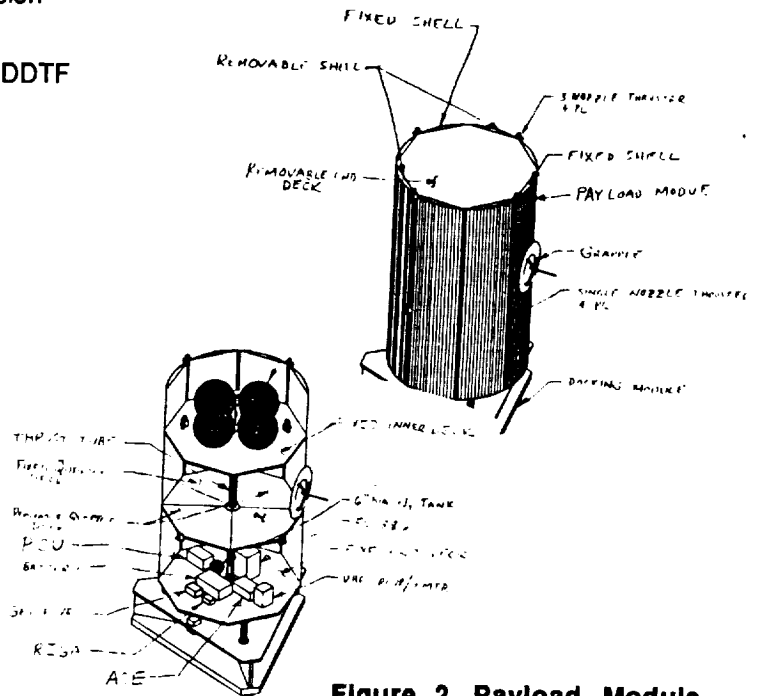

Figure 2 Payload Module

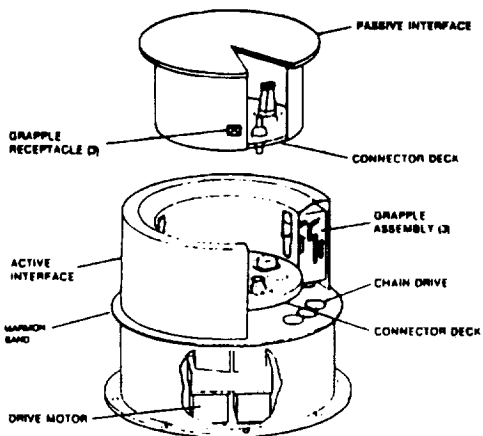

Figure 3 Resupply Interface Mechanism (RIM)

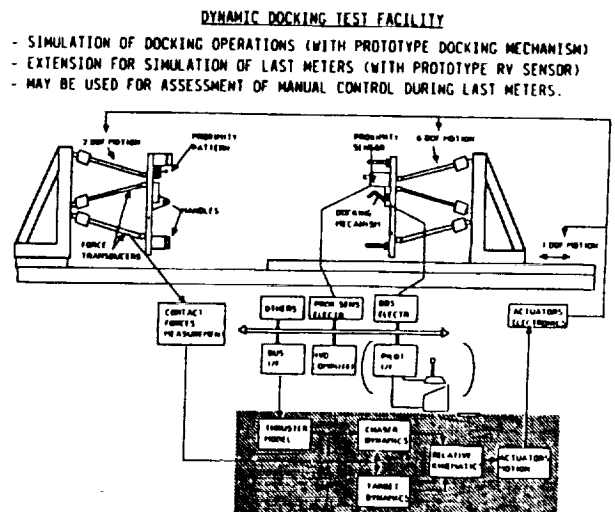

Figure 4 CNES Dynamic Docking Test Facility

1981

1982

1983

1984

1985

1986

1987

1988

1989

1990

1991

1992

1993

1994

1995



Abstract submission for the AR&C conference at Williamsburg,
Virginia on Nov. 19-21, 1991.

N 93-22267

SAI-19

ABS ONLY

146752

P. 2

Category 1: Hardware Systems: Sensors and Targets

Title: Video Guidance Sensor for Autonomous Capture

By: Richard T. Howard Michael L. Book NASA/MSFC
Ph: (205) 544-3536 Ph: (205) 544-3699 FAX: (205) 544-5864
FTS: 824-3536 FTS: 824-3699

A video-based sensor has been developed specifically for the close-ranged maneuvering required in the last phase of autonomous rendezvous and capture. The system is a combination of target and sensor, with the target being a modified version of the standard target used by the astronauts with the Remote Manipulator System (RMS). The system, as currently configured, works well for autonomous docking maneuvers from approximately forty feet in to soft-docking and capture.

The sensor was developed specifically to track and calculate its position and attitude relative to a target consisting of three retro-reflective spots, equally spaced, with the center spot being on a pole. This target configuration was chosen for its sensitivity to small amounts of relative pitch and yaw and because it could be used with a small modification to the standard RMS target already in use by NASA.

Work began on this system under the Research and Technology Objectives and Plans (RTOP) program in 1987 under an Automation and Robotics task. The system was to use a Charge Injection Device (CID) as its detector, laser diodes as illuminators, and corner-cube retro-reflectors for the target. Eventually, the Retro-reflector Field Tracker (RFT) was available for use, and it already utilized a CID sensor and laser diode illuminators. Its target was retro-reflective tape, which was even easier to use with the RMS target than corner-cubes. The sensor was used in a closed-loop mode for automatic docking at MSFC's Flight Robotics Laboratory in December of 1987. The RFT was a sensor that flew on the shuttle in the Solar Array Flight Experiment in 1984. It worked very well for automated docking, but only with an entirely black background. That would not do for a sensor that would be facing highly reflective satellites. The next step was to develop a sensor that could acquire and track a target despite reflections from other things in the background, most notably the multi-layer insulation on many spacecraft. A new sensor was built around a standard Charge-Coupled Device (CCD) camera, two different wavelengths of laser diodes, and retro-reflectors with optical narrow-band-pass filters in front of them, designed to pass one of the two laser diode wavelengths.

The current sensor works by turning on one set of laser diodes, at 830nm wavelength, and digitizing a picture of the illuminated target; then the sensor turns on the second set of laser diodes at 780nm and digitizes a second picture. Since there is a narrow-optical-bandpass filter in front of the retro-

reflectors on the target, the laser light is returned by the three target spots at 830nm but not at 780nm. The second picture is then subtracted from the first picture to give a low-noise image of the target spots. From the centroids of these three spots, and the knowledge of the actual physical configuration of the reflectors, the position and attitude of the target relative to the sensor are calculated for all six-degrees-of-freedom. This information can be fed into a guidance routine to allow automatic docking/berthing or it can be put on a screen to facilitate man-controlled docking/berthing.

The system has been used for large-scale autonomous docking simulations and tests at MSFC's Flight Robotics Laboratory. It was first used to autonomously guide an Air-Bearing Vehicle (ABV) with freedom in the X, Y, and Yaw axes. The ABV, which weighs 2000kg, is powered by batteries on board and propelled by compressed air thrusters. The sensor was later integrated into the Orbital Maneuvering Vehicle (OMV) model on the Dynamic Overhead Simulator, which has six-degrees-of-freedom and a longer range of travel than the ABV. Some of the work on the OMV application involved TRW, the OMV prime contractor prior to its cancellation. Their work mostly involved automated guidance routines as well as integration of the sensor data into the OMV's guidance system.

As currently configured, the system has a maximum range of approximately 12 meters and a 30x30 degree field-of-illumination. The camera in the sensor has a field-of-view of 45x45 degrees, and the video signal from that camera is available for use in manned supervision. With the same sensor, by using a larger target and corner cube reflectors, a range of 45 meters has been tested. Various other options are available to obtain different ranges and depths of operation, including changing the lens used in the sensor, increasing the number and/or power, of the laser diodes, changing the illumination field of the laser diodes, using more than one lens or camera, or making the target larger and with more than one sub-target.

The funding for this research has been from Code RC under the Autonomous Rendezvous and Docking RTOP program. Also, one sensor was funded by the Space Station program for use in testing the SSF module berthing and evaluating the sensor as a possible aid to the actual berthing process. As of now there is no firm amount of funding for FY92 to continue research in this area.

The research and experimentation on this system has been ongoing for over four years, and the next step in the evolution of a system such as this one is a flight test or the use of this system with a real application. Further research will more closely define the parameters of operation of the system and reveal more of the possible configurations, but without an actual application, there is not a target to capture.

TALON AND CRADLE - SYSTEMS FOR THE RESCUE OF TUMBLING
SPACECRAFT AND ASTRONAUTS

542-54
ABS ONLY
146753
P, 1

Dunning Idle V, Ph.D.

Advanced pressure suit and tool designs are beginning to allow extravehicular astronauts to repair space vehicles and so increase mission life and system reliability. A common spacecraft failure that is a severe challenge to the rescue mission planner is loss of attitude control resulting in tumbling motion. If an extravehicular astronaut flying the Manned Maneuvering Unit (MMU) "falls" into a tumble, the result could be loss of life.

TALON (Tumble Arresting Large Oscillation Nullifier) is a device capable of capturing a target in an uncontrolled three-axis tumble. CRADLE (Concentric Rotating Astronaut Detumble Lifesaving Equipment) is a similar device sized to rescue a suited astronaut. The two rescue vehicles work on the same basic principle. They are structural shells with articulated limbs which can surround a tumbling target and thus align both the chaser and target centers of mass (CM).

Adjusting chaser mass geometry to match the target principal Inertia Moment Ratios (IMRs) enables the chaser to spin up into a torque free tumble that is identical to that of the target. The target will be motionless in the chaser frame and thus be easily grappled.

To automate TALON or CRADLE requires a knowledge of the target attitude, attitude rates, and inertia moment ratios. These can be obtained through computer analysis of data provided by either stereo video cameras or a laser range finder. By observing three non-colinear target surface points, we can use standard numerical estimation techniques to derive the target tumble state parameters, as well as the location of the center of mass.

Initializing the estimator requires *a priori* information concerning the target state. Consecutive body frame attitude can be used to find the direction and magnitude of angular velocity. This information, along with the direction of target angular momentum, can be used to find the locations of principal axes of inertia, as well as the ratios between principal moments of inertia. Searching for the body fixed point that travels the smallest distance in inertial space over the observation interval will lead to the location of the target CM.

CLEARED - ABSTRACT ONLY

FINAL PAPER MUST BE
SUBMITTED FOR REVIEW

PL/PA 25 FEB 91

CLEARANCE OF ABSTRACT DOES
NOT SATISFY REQUIREMENT FOR
CLEARANCE OF ENTIRE PAPER.

[Faint, illegible text covering the majority of the page, likely bleed-through from the reverse side.]



Space Shuttle Program - Automatic Rendezvous, Proximity
Operations, and Capture (Category 3)

5/13/13
ABS. ONLY
146754
P. 3

W. L. Jackson; JSC/EG;
Phone: 713-483-8303; FAX 713-483-6134;
Electronic Mail ID: JACKSON_WILLIAM (All-in-One)

R. Lee; TRW Houston;
Phone: 713-333-3133; FAX: 713-333-1875;
Electronic Mail ID: LEE_ROSCOE (All-in-One),
RLEE (NASAMAIL)

O. W. Olszewski; LESC/C19;
Phone: 713-333-6218; FAX: 713-333-7201;
Electronic Mail ID: Olszewski@LOCKJSC.NASA.GOV
(All-in-One)

R. E. Eick; TRW Houston;
Phone: 713-333-3133; FAX: 713-333-1875;
Electronic Mail ID: EICK_RICHARD (All-in-One)

J. L. Prather; JSC/EE;
Phone: 713-483-1483; FAX: 713-483-5830;
Electronic Mail ID: PRATHER_JOSEPH@A1@TCD
(All-in-One)

J. V. Hallstrom; RSOC/R14E;
Phone: 282-4578; FAX: 713-282-4095

D. L. Rue; TRW Houston;
Phone: 713-333-3133; FAX: 713-333-1875;
Electronic Mail ID: DRUE (NASAMAIL)

H. K. Hiers; JSC/ER2;
Phone: 713-483-2036; FAX: 713-483-3204;
Electronic Mail ID: HIERS_HARRY@A1@CTSD2
(All-in-One)

K. J. Zimmer; JSC/ER3;
Phone: 713-483-1718; FAX: 713-483-3204;
Electronic Mail ID: ZIMMER_KARL@A1@CTSD2

J. P. McManamen; JSC/ES6;
Phone: 713-483-8958; FAX: 713-483-6216;
Electronic Mail ID: MCMANAMEN_JOHN@A1@SMD
(All-in-One)

Abstract:

The NASA Johnson Space Center is actively pursuing the development and demonstration of capabilities for automatic rendezvous, proximity operations, and capture (AR&C) using the Space Shuttle as the active vehicle. This activity combines the technologies, expertise, tools, and facilities of the JSC Tracking and Communications Division (EE), Navigation, Control and Aeronautics Division (EG), Automation and Robotics Division (ER), and Structures and Mechanics Division (ES) of the Engineering Directorate and the Flight Design and Dynamics Division (DM) of the Mission Operations Directorate.

Potential benefits of AR&C include more efficient and repeatable rendezvous, proximity operations, and capture operations; reduced impacts on the target vehicles (e.g., Orbiter RCS plume loads); reduced flight crew work loads; reduced ground support requirements; and reduced operational constraints.

This paper documents the current JSC capabilities/tools/facilities for AR&C and describes a proposed plan for a progression of ground demonstrations and flight tests and demonstrations of AR&C capabilities. This plan involves the maturing of existing technologies in tracking and communications; guidance, navigation and control; mechanisms; manipulators; and systems

management and integrating them into several evolutionary demonstration stages.

The systems/disciplines which are key to AR&C include: tracking and communications, GN&C, docking mechanisms, manipulators, operations management, systems management, and system integration. The white paper describes the current capabilities and associated technology readiness levels, system tradeoffs, key development needs, tools and facilities (in place and needed), development schedules, and related industry activities for each of these systems and disciplines.

The key technology needs for each of these systems for the proposed set of AR&C demonstrations are summarized as follows:

Tracking and Communications:

- Development of laser sensors (e.g., range finder, proximity operations sensors, and capture/release sensors)

- GPS development, ground test, and flight test

GN&C:

- Selection of applicable proximity operations translational state targeting and guidance
- Upgrade of Orbiter proximity operations navigation (e.g., incorporate GPS and/or laser sensor)
- Upgrade of Orbiter On-Orbit Flight Control System for automatic stationkeeping and blended translation/rotation control

Docking Mechanisms:

- Increased sophistication in controllers/sensors (e.g., active docking mechanisms, contact sensors, mechanisms controllers)
- Integration of sensors and controllers with mechanisms

Manipulators:

- Addition of real-time sensors (e.g., point of resolution position and attitude, force and torque sensors, proximity operations sensors) to support an enhanced autosequence mode
- Automated track and capture capability for SRMS

Systems Management:

- Enhanced displays for monitoring and control during proximity operations (e.g., Crew Optical Alignment Sight (COAS)/Target icon display, relative motion trajectory plots)

- Real-time collision risk assessment for capture/release operations

Operations Management:

- Flight qualifiable automatic mission replanning expert system

The key AR&C system development and integration needs include:

- Development of operations ground rules and flight rules for candidate automatic systems
- Merging software point designs and related hardware prototypes into integrated systems
- Incorporation of AR&C demonstration hardware and software into the host vehicle (e.g., Orbiter) without compromising the integrity of the operational flight system
- Development of a Rapid Integrated Prototyping Environment (RIPE) Lab for integrating AR&C analyses
- Establishment of criteria and plans for system verification methods (e.g., engineering analysis/simulations, ground demonstration, and flight demonstrations)

Source / Sponsorship:

The proposed demonstration activity is being sponsored by NASA/JSC with the lead integration and GN&C development effort being sponsored by the Navigation, Control and Aeronautics Division. Other JSC divisions including the Tracking and Communications Division, Automation and Robotics Division, Structure and Mechanics Division, and the Flight Design and Dynamics Division are sponsoring their contributing activities.

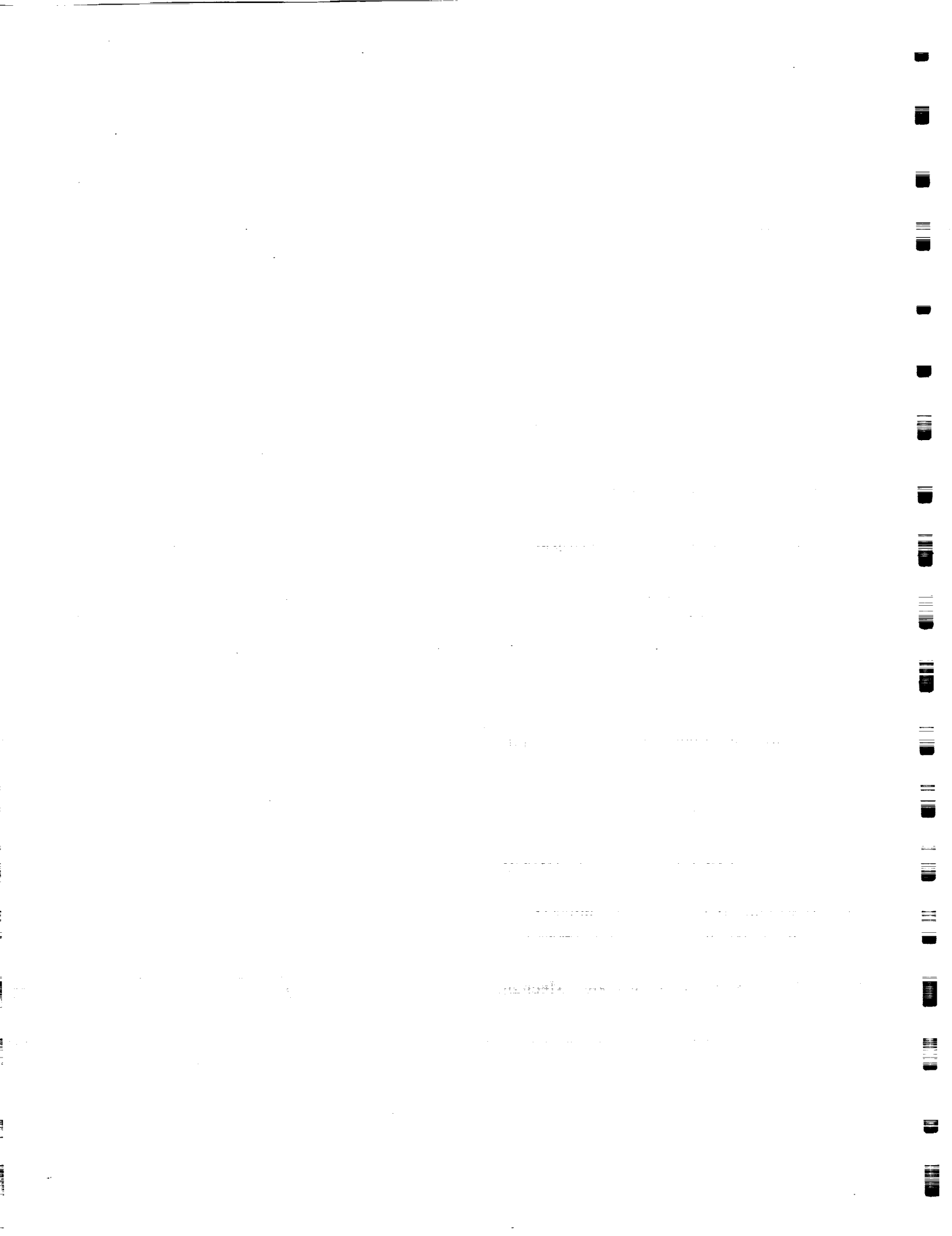

CTV RENDEZVOUS TECHNIQUES

Jerry L. Jennings
Robert L. Anderson



Federal Systems Division
1 Space Park Bldg. R11/2337
Redondo Beach, CA 90278
(213)812-2627 Phone
(213)812-8016 FAX

544-13
N 93-22270
ABS. 6/27

1416755

P-2

Statement of technical details of the capability being described

The cargo transfer vehicle (CTV) requires the capability to perform automated rendezvous with Space Station Freedom (SSF) using onboard sensors and algorithms. The current approach to CTV rendezvous applies techniques developed during the orbital maneuvering vehicle (OMV) program which have been mechanized for automatic, onboard execution. The initial catch up sequence can be described as a passive rendezvous without explicit time of arrival control. The ultimate requirement for this rendezvous technique is to place the CTV on the SSF V-bar axis at some specified downrange distance. The launch vehicle will use yaw steering during orbit injection to achieve the proper phantom plane for nodal biasing. This presentation describes the primary components of the CTV rendezvous scheme.

The CTV rendezvous scheme is composed of 6 primary components which are:

- a. Perigee adjustment - initial injection into the phasing orbit following main engine cutoff (MECO)
- b. Rendezvous phasing - phasing coast varying from a few to many tens of hours with delta-V maneuvers performed only for maintaining the J2 bias plane
- c. Apical translation - a targeted adjustment of the phasing perigee into an intermediate phasing orbit which guarantees that perigee will occur at a required target relative phase angle after a specific number of intermediate phasing revolutions
- d. Stable orbit injection - a targeted transfer from the intermediate phasing orbit perigee to the target V-bar stable orbit axis outside of the SSF proximity control zone
- e. Stable orbit rendezvous - a series of targeted transfers which cause travel along the target V-bar stable orbit axis and terminates in close proximity to the target
- f. Proximity operations - final, 6 degree of freedom (6DOF) closed loop control in close proximity to the target.

Each of the above rendezvous segments will be discussed and key issues and design drivers which affect the CTV functional requirements will be presented. Results from analysis and 6 DOF simulations will be given to show the characteristics of this rendezvous scheme.

History of the origins and evolution of the capability

TRW has broad experience in the area of autonomous proximity operations, autonomous docking, auto rendezvous, and 6 DOF control of maneuvering spacecraft. This experience is derived from the OMV contract and TRW IRAD programs.

The level of maturity of the capability

The capability for autonomous rendezvous and autonomous proximity operations is currently evolving and requirements are being generated and validated through extensive simulations. TRW's IRAD program is currently addressing the issues of autonomous proximity and docking technologies as well as automated rendezvous. In addition, TRW is supporting the CTV study efforts.

Test experience and/or experimental results

The automated guidance, navigation, and control algorithms have been implemented in the orbital maneuvering and servicing simulator (OMSS) at TRW. In addition, CTV configurations and mission scenarios have been generated and are being evaluated using the OMSS.

Source/sponsorship and current funding estimates

This work is currently supported by the CTV study contract.

ON-ORBIT OPERATIONAL SCENARIOS, TOOLS AND TECHNIQUES

by Jerry Jennings & Jim Walker

TRW
Space and Technology Group
Federal Systems Division
1 Space Park Dr., R11/1313
Redondo Beach, California
(213)812-0852 Phone
(213)812-7296 FAX

545-12
ABS ONLY
N 93-22271
146756
P. 3

Statement of technical details of the capability being described

This paper concentrates on methods and techniques used to the develop operational scenarios for orbital missions, including development of models to analyze alternatives, modification of tools and refinement of techniques for future missions. Many of these tools and techniques have been derived from previous tools, techniques and experience from the Orbital Maneuvering Vehicle (OMV) program. Results from use of these tools show the current Cargo Transfer Vehicle nominal mission scenario, with 95 discrete events defined for the CTV mission from the NLS Heavy Lift Launch Vehicle(HLLV) to Space Station Freedom(SSF).

History of the origins and evolution of the capability

The capabilities were originally developed for use on the OMV program in order to assess missions and parameters. The tools and techniques were used to define, analyze and refine the sequences of events for the twelve (12) design reference missions defined for the OMV. In addition, the capabilities proved valuable in analysis completed for other OMV studies such as "Manrating OMV", Shuttle C studies and the OMV/ELV compatibility study.

The preliminary orbital mission definition for the Cargo Transfer Vehicle (CTV) was defined by a NASA/MSFC data package dated May 28, 1991. The on-orbit missions defined for the CTV are payload deployment and delivery of payload to Space Station Freedom(SSF). These missions are very similar to some of the OMV design reference missions mentioned previously. The requirements for the CTV/SSF mission are stabilization, attitude reference, transfer of a 100,000 lb payload from the NLS Heavy Lift Launch Vehicle (HLLV) to the Space Station control zone, rendezvous, proximity operations and stabilization for berthing by the SSF. Alternatives for completion of this mission are described along with the tools used to complete the tradeoffs. Operational drivers for the CTV design include the Space Station location(altitude and ascending node),

ON-ORBIT OPERATIONAL SCENARIOS, TOOLS AND TECHNIQUES (Page 2) by Jerry Jennings and Jim Walker

History of the origins and evolution of the capability (continued) mission time, time for phasing to the Space Station, holds near the Space Station, return phasing coming back to the SSF after a recovery mission, approach to and interfaces with the SSF, propellant requirements for the nominal and alternative missions and the resulting power requirements (driven by time and the vehicle state). A design reference (worst case) sequence of events has been defined for requirements development purposes. These sequences are shown on detailed tables which illustrate use of the tools developed to to quickly assess alternatives and summarize mission plans. These tools will be refined and expanded for the current CTV/Space Station delivery mission and future CTV mission requirements.

The level of maturity of the capability

The tools and techniques described in this paper were very mature when developed for the OMV program. The evolving tools and techniques for the CTV program are, because of the similarity to OMV mission requirements, very mature compared to other NLS program tools and techniques. There will be a period of refinement of the tools and techniques as the CTV program continues to develop.

Test experience and/or experimental results

To illustrate the capabilities described, a comparison of the primary mission options & para versions of the CTV mission are shown. Techniques for accomplishing the mission are discussed in detail including how the tools are used, alternatives developed, requirements for phasing back to the Space Station after a disposal mission, and the cumulative mission planning effects of long "holds" currently baselined for the mission. Conclusions are presented which identify future refinements recommended for these tools and techniques.

Source/sponsorship and current funding estimates

These tools and techniques were initially developed on the OMV program under contract to NASA/MSFC. Refinement is continuing as part of the NLS Definition Study funded by NASA/MSFC through April, 1992.

ON-ORBIT OPERATIONAL SCENARIOS, TOOLS AND TECHNIQUES (PAGE 3)

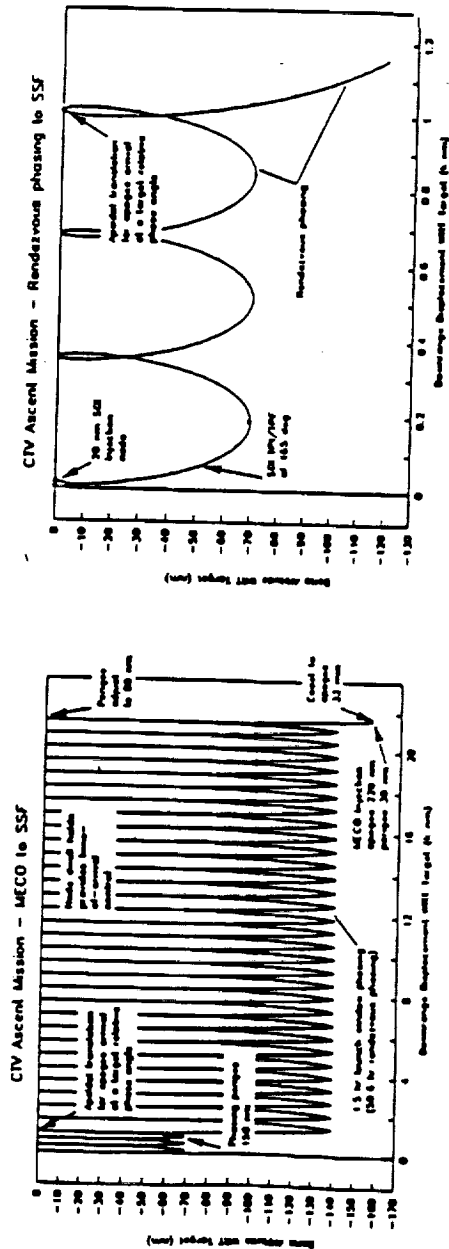

COMPARISON OF MISSION SCENARIOS MSFC VS. TRW ALTERNATIVES

PARAMETER	UNITS	MSFC REFERENCE 5/28/91	TRW VERSION 8/19/91	TRW ALTERNATE #1 (20 PIM L/W)	TRW BASELINE (1.5 PIM L/W 9/19/91)	DISPOSE OF PAYLOAD CONTINGENCY
INITIAL ORBIT						
L/W PHASING ORBIT	M _T X M _T	30 X 200	30 X 200	30 X 220	30 X 220	30 X 220
RENDEZ PHASE ORBIT	M _T X M _T	100 X 200	100 X 200	80 X 220	80 X 220	80 X 220
COAST-L/W PHASING	M _T X M _T	200 X 200	200 X 200	80 X 220	150 X 220	150 X 220
HOLD OUTSIDE CCZ	HOURS	10.5 HR	10.5	10.5	48.3	48.3
TIME-BERTH AT SSF	HOURS	0	40	40	48	48
TIME OF DEORBIT BURN	HR:MM:SS	15:01	57:07	54:47	112:20	N/A
TIME-DEORBIT TO BERTH	DO:MM:SS	14:21:40	16:13:36	16:10:16	19:01:10	4:20:07
UNLOAD TIME AT SSF	MM:SS	3:42	14:44	13:09	31:00**	31:00**
TOTAL ELAPSED TIME	DO:MM:SS	14:28:00	17:04:20	14 DAYS	14 DAYS	N/A
TOTAL DELTAV	FPS	1463	1892	1892	20:08:25	01:11:20***
ST. TOTAL ENERGY	KG-O-WAITS	28	41	39	83	1093
COMMENTS:		MSFC baseline in MRA Contractors' package	Includes Delta V need to phase back to SSF after disposal		** Includes an additional 12 hrs held prior to entering SSF CCZ	*** Includes 3 attempts to berth, then disposal of P/L's and return to SSF

ORIGINAL PAGE IS
OF POOR QUALITY

TRW Federal Systems
Space & Technology Group

DRAFT
CTV MISSION TIMELINE

Event	Time (hr:min:sec)	Duration (hr:min:sec)	Start (hr:min:sec)	End (hr:min:sec)	Notes
0	00:00:00	00:00:00	00:00:00	00:00:00	Start of Mission
1	00:00:00	00:00:00	00:00:00	00:00:00	MECO Injection
2	00:00:00	00:00:00	00:00:00	00:00:00	Coast to SSF
3	00:00:00	00:00:00	00:00:00	00:00:00	Rendezvous Phasing
4	00:00:00	00:00:00	00:00:00	00:00:00	Coast to SSF
5	00:00:00	00:00:00	00:00:00	00:00:00	Time to Berth
6	00:00:00	00:00:00	00:00:00	00:00:00	Unloading
7	00:00:00	00:00:00	00:00:00	00:00:00	Disposal
8	00:00:00	00:00:00	00:00:00	00:00:00	End of Mission

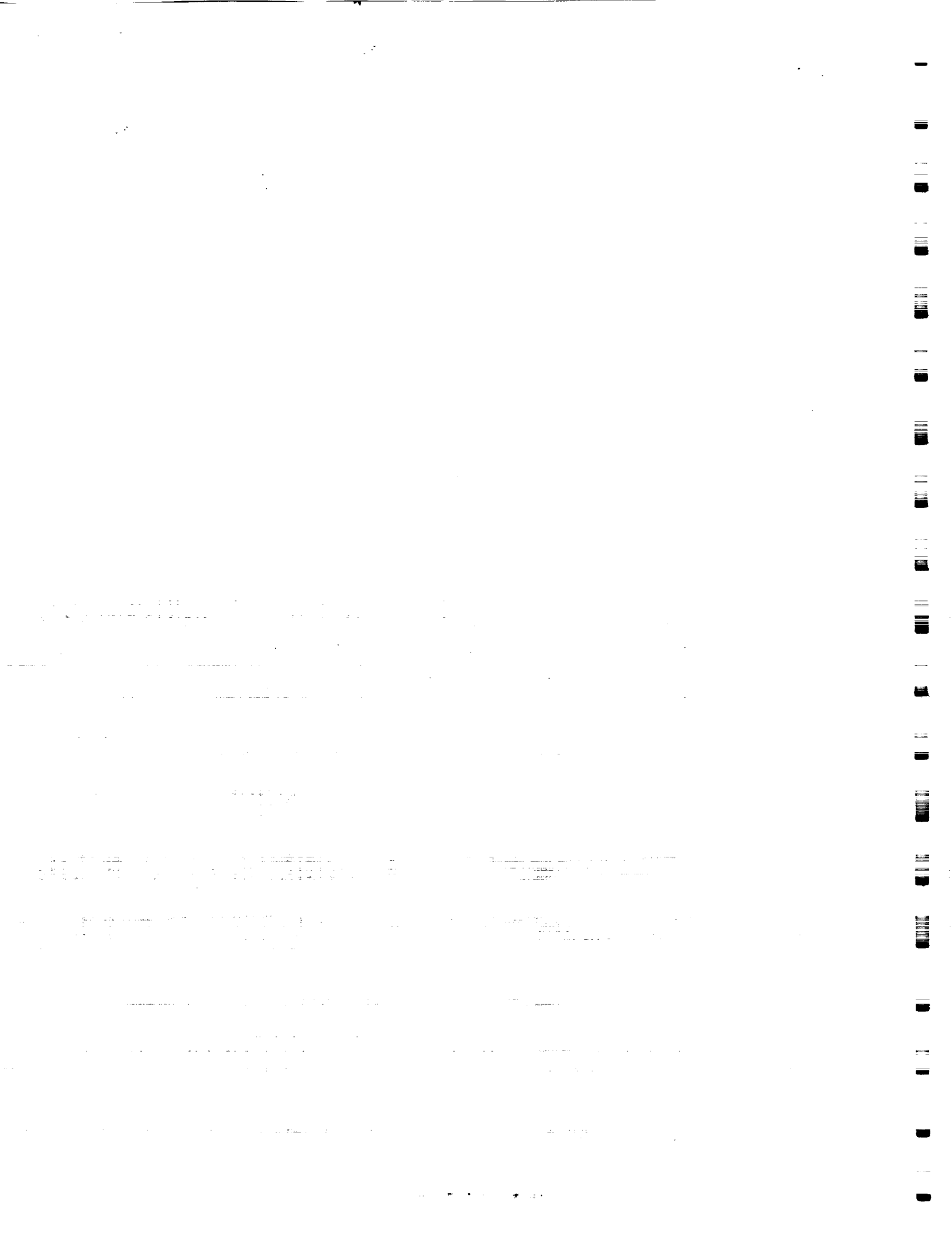

U.S. Automated Rendezvous and Capture Capabilities Review
Category 3 - Integrated Systems

546-13
146920

P. 2

Abstract Title: An Autonomous Rendezvous and Docking System
Using Cruise Missile Technologies

Author: Ruel Edwin Jones

N 93 - 22272

Affiliation: General Dynamics, Space Systems Division
P.O. Box 85990, San Diego, Ca. 92186-5990
MZ 24-8710

Technical Details:

In November 1990 the Autonomous Rendezvous & Docking (AR&D) system was first demonstrated for members of NASA's Strategic Avionics Technology Working Group. This simulation utilized prototype hardware from the Cruise Missile and Advanced Centaur Avionics systems. The object was to show that all the accuracy, reliability and operational requirements established for a space craft to dock with Space Station Freedom could be met by the proposed system. The rapid prototyping capabilities of the Advanced Avionics Systems Development Laboratory were used to evaluate the proposed system in a real time, hardware in the loop simulation of the rendezvous and docking reference mission. The simulation permits manual, supervised automatic and fully autonomous operations to be evaluated. It is also being upgraded to be able to test an Autonomous Approach and Landing (AA&L) system. The AA&L and AR&D systems are very similar. Both use inertial guidance and control systems supplemented by GPS. Both use an Image Processing System (IPS), for target recognition and tracking. The IPS includes a general purpose multiprocessor computer and a selected suite of sensors that will provide the required relative position and orientation data. Graphic displays can also be generated by the computer, providing the astronaut / operator with real-time guidance and navigation data with enhanced video or sensor imagery.

Historical Background:

The Cruise Missile avionics have evolved, since 1971, to a system, currently in flight test, that uses a similar suite of sensors as the baseline Autonomous Rendezvous and Docking system. This Cruise Missile system, combines a GPS referenced inertial guidance system with an Image Processing System (IPS). The GPS has added considerable robustness to system performance by providing very accurate and consistent position data. The IPS can use video, ladar and \ or FLIR to provide the required accuracy during the terminal guidance phase.

The advanced Centaur avionics system has evolved very rapidly over the past four years. It now has a scaleable architecture utilizing state-of-the-art

strap-down inertial sensors and processor technology. The baseline AR&D system uses a Triple Modular Redundant configuration to meet the projected reliability requirements for an Expendable Launch Vehicle servicing Space Station Freedom..

Technology Maturity:

The Centaur and Cruise Missile avionics systems have been evolving for twenty years. Integration of GPS into both systems has been underway for over five years with a follow-on cruise missile system currently in flight test. Rendezvous and Docking related studies have been conducted for over five years in support of the Advanced Upper Stage, OMV and other IR&Ds. The system and AR&D simulator demonstrated to the SATWG has been upgraded considerably under two IR&D programs in 1991. New acquisition and tracking algorithms have added the necessary robustness to the image processor control loop so different sensors and interfacing filters to the autopilot can be evaluated. New interactive summary displays were added to allow real time monitoring and post test system performance analysis.

Test Experience:

The Centaur and Cruise Missile avionics systems have been tested and operationally validated for over twenty years. The combined AR&D system has been under development and testing for a year. A Joint NASA / GD ARD&L System Test Program is currently being planned to validate several aspects of system performance in three different NASA test facilities in 1992.

Sponsorship and Funding:

Currently, the development of the integrated rendezvous and docking system is being pursued on IR&D funding. General Dynamics is working with Johnson Space Center, Marshall Space Flight Center, and Langley Research Center in a cooperative test and demonstration effort. This multi-center program combines the expertise and testing capabilities to establish and validate a performance baseline for autonomous rendezvous, docking and landing systems.

Biography:

Edwin Jones received the B.S. and M.S. degrees from Brigham Young University in 1965 and 1969 in Physics and Psychology, (Human Engineering)..Mr. Jones has worked on aerospace programs for over thirty years. His assignments have ranged from teaching GAM 77 air launched cruise missile systems to system design, payload integration and launch site integration at Vandenberg AFB on the Space Shuttle Program. During the Apollo Soyuz program, he taught the Docking system to NASA astronauts, flight controllers, and Soviet Cosmonauts. Eds current assignment is principle investigator on the joint General Dynamics / NASA Autonomous Rendezvous, Docking and Landing System Test Program.

Optical Correlators for Automated Rendezvous and Capture

Richard Juday
 NASA Johnson Space Center
 Tracking and Communications Division
 Phone: 713/483-1486
 FAX: 713/483-5830
 Email: juday@ttb.jsc.nasa.gov

547-74
 NBS ONLY
 146757
 P - 2

Two dimensional image correlation is a robust technique for recognizing known objects and determining their position with respect to the sensing platform. This capability is of paramount importance to vehicles which must rendezvous and capture using only on-board sensors and processors. Standard digital processors can provide the necessary correlations, but their speed, weight, size and power consumption make them undesirable components of an on-board tracking system. Optical correlators provide correlation results comparable to digital systems, but with a fraction of the size, weight and power and often many times faster. This presentation discusses the application of optical correlators to Automated Rendezvous & Capture (AR&C), and the specific work being done at the Johnson Space Center and DARPA in developing optical correlator technology.

The Johnson Space Center (JSC) has been pursuing hardware and algorithm development for optical correlators since 1985. JSC has pioneered key hardware developments in the form of Spatial Light Modulators (SLMs) and algorithms for building "smart" correlation filters. JSC is also closely involved with a multi-million dollar Defense Advanced Research Projects Agency (DARPA) effort to build optical correlators for fieldable systems. JSC is providing SLM hardware development, filter theory and operational considerations for the DARPA effort. This DARPA project will result in two optical correlator systems which will be small enough and rugged enough to fit inside a missile and will perform hundreds of correlation measurements per second. Comparable digital implementations would be significantly larger and slower. These optical correlators will be complete in the Fall of 1993. This time frame and form factor make optical correlation a very attractive technology for NASA's near-term automated missions requiring Automated Rendezvous and Capture (AR&C) capability such as Lunar/Mars missions, Cargo Transfer Vehicle (CTV) and others.

While DARPA is providing the optical correlator optics and system electronics, JSC has been developing SLM hardware and filter algorithms to insert into these systems. Spatial Light Modulators are the electro-optic devices which encode the image or filter information onto the laser beam. Once the information is encoded onto the laser beam, the physics of optics and the propagation of light perform the necessary processing. It is this ability to encode the image information onto the laser beam which has made *optical* correlators viable. JSC has been pioneering the development of a

specific type of spatial light modulator with Texas Instruments (TI) known as a Deformable Mirror Device (DMD). The TI DMD provides orders of magnitude greater light efficiency, light processing capability and size reduction over competing SLMs. The DMD development is proceeding in parallel with the hardware being developed by DARPA and will be ready to support the final systems in 1993.

Currently available DMDs have been used in our research at JSC for over four years. In that time, we have developed sophisticated algorithms to not only compensate for the realistic performance of the device, but also for optimizing the correlation process in the presence of various types of noise. This optimization of the correlation process with realistic devices has given us significant signal to noise improvements and has allowed us to do more with a filter than just compare an input scene with a reference object. With these techniques we can improve the robustness of the correlation process to compensate for distortions in the input scene (in-plane and out-of-plane object rotations and magnification differences). In addition, we can apply multiple filters to a scene to *estimate* these distortion parameters allowing us to recognize the target and its pose with reduced filter storage requirements. These techniques combine to improve the robustness of the optical correlation process while reducing its storage requirements.

Correlation by itself is a very powerful target identification technique. Optical correlators have significantly improved the size, weight and power requirements, increased the operating speed, and maintain comparable accuracy of digital systems. Optical implementations of correlators are becoming very mature. The DARPA correlators will demonstrate the form factors achievable with optics, and JSC's involvement with the program will ensure that they are thoroughly tested in NASA's applications.



548 13
1135 ONLY
146758
N 93-22274

**Automatic Rendezvous and Capture System Development
in an
Manned Environment**

by

Peter M. Kachmar, C.S. Draper Laboratory
William Jackson, NASA - Johnson Space Center

ABSTRACT

This paper presents the development of a "Phase One" AR&C system capability as a logical outgrowth of Rendezvous and Proximity Operations (R&PO) system development for manned space programs. The continuity of the approach to R&PO across the Apollo, Skylab, Apollo-Soyuz, and Shuttle programs is traced and lessons learned which are applicable to AR&C discussed. Use of the Shuttle as a test bed for Automatic Rendezvous and Capture capabilities and technology demonstrations is discussed. A status of the current Phase One System design and brief overview of its capabilities is presented.

Draper Laboratory (formerly the M.I.T. Instrumentation Laboratory), designed the Apollo IGN&C rendezvous system and, with NASA Johnson Space Center, developed the operational procedures and final rendezvous profile for the Apollo missions. The Apollo system was initially developed as an automatic system. Modifications were subsequently made to provide the flexible manned operational capability successfully demonstrated throughout the program. Following Apollo, Draper has had a principal role with JSC in the development of IGN&C rendezvous systems for the major U.S. space programs.

IGN&C rendezvous system development from Gemini, Apollo, Skylab and Shuttle has provided the unique opportunity to design and evaluate most of the component systems of a complete automatic rendezvous and capture system. On-orbit operational experience with these integrated systems during actual rendezvous and proximity operations has provided an opportunity to demonstrate rendezvous and proximity operations capabilities and validate the design methodologies employed.

Development and testing of flight proven IGN&C systems using computer simulation has required the development of a rule-based expert system to perform the manual system operations as well as the development of an automated (digital) pilot to perform the trajectory control functions during proximity operations. These development

applications have matured to a level that, coupled with the proven designs of the IGN&C flight systems themselves, provide the requisite capabilities of a "Phase One" AR&C system.

Since this Phase One AR&C system was initially developed to simulate manned rendezvous and proximity operations, as an automated system it may be easily monitored by human operators and can be implemented with the capability of manned takeover should the need arise.

Authors:

Peter M. Kachmar

IGN&C Systems Section Head, C.S.Draper Laboratory
555 Technology Square Cambridge, MA. 02139

Phone: 617-258-2431 FAX: 617-565-8674

William Jackson

Guidance/Proximity Operations Section Head

NASA Johnson Space Center Houston, Tx 77058

Phone: 713-483-8303 FAX: 713-483-6134



549-18
ABS ONLY
N 93-22275
P-2

Performance Capabilities
of a
"Phase One" Automatic Rendezvous and Capture System

by

Peter M. Kachmar, Draper Laboratory
Robert J. Polutchko, Draper Laboratory
Martin Matusky, Draper Laboratory

ABSTRACT

This paper presents an analysis of the performance of the existing "Phase One" AR&C system developed at the C.S. Draper Laboratory for both the rendezvous and proximity operations mission phases. This material has been developed as a result of Draper Laboratory involvement through NASA's Johnson Space Center in the development of the flight proven IGN&C rendezvous systems for Apollo, Skylab, and Shuttle. The development of these systems using Draper computer simulations has required automation of all crew inputs to the IGN&C system and thus provided the unique opportunity to develop and test those system capabilities required for AR&C. This paper expands upon the material in the papers presented by the authors at the NASA Autonomous Rendezvous and Docking Conference held at JSC on August 15-16, 1991.

As an introduction, the IGN&C architecture of Automated Rendezvous and Capture system which has evolved out of Draper's extensive experience with manned IGN&C rendezvous systems is reviewed. Changes and additions to the current Space Shuttle IGN&C system implemented in this "Phase One" system to provide an AR&C capability are highlighted. Since this system has evolved from a manned approach to rendezvous and proximity operations, it is shown that provisions for human operators to monitor operation and a manned take-over capability are easily incorporated.

Performance data for this "Phase One" AR&C system will be presented in order to assess operations throughout the approach profile, from the initiation of the rendezvous mission phase through the proximity operations phase, to the capture condition. Figures of merit for rendezvous and proximity operations performance are identified and employed to compare the performance of the system in several rendezvous and proximity operations

scenarios. A comparison to manned system performance is established. Performance of an AR&C capable Shuttle during operations with SSF is addressed.

This performance data presented has been generated at the Draper Laboratory using linear covariance and deterministic analysis simulations of a Space Shuttle vehicle. The asymmetrical mass properties and complex set of RSC jets make the Space Shuttle an excellent example of a highly coupled "generic" spacecraft. Under contract to NASA Johnson, these simulations have been used to support flight techniques development, to define performance bounds for flight rules, to assess system performance and capability, to provide signature data for flight software verification, and to conduct detailed post-flight analyses.

Planned enhancements to this "Phase One" system, and additional capabilities required by a flight ready AR&C system are outlined in terms of a phased approach to AR&C capability development .

Authors:

Peter M. Kachmar

IGN&C Systems Section Head, C.S.Draper Laboratory

555 Technology Square Cambridge, MA. 02139

Phone: 617-258-2431 FAX: 617-565-8674

Robert J. Polutchko

IGN&C Systems Technical Staff, C.S.Draper Laboratory

555 Technology Square Cambridge, MA. 02139

Phone: 617-258-3177 FAX: 617-565-8674

Martin M. Matusky

IGN&C Systems Technical Staff, C.S.Draper Laboratory

555 Technology Square Cambridge, MA. 02139

Phone: 617-258-2440 FAX: 617-565-8674



550 17
ABS ONLY
-146760
N 93 - 22276
P

Relative Navigation Requirements
for
Automatic Rendezvous and Capture Systems

by

Peter M. Kachmar, Draper Laboratory
Robert J. Polutchko, Draper Laboratory
William Chu, Draper Laboratory
Moises Montez, NASA - Johnson Space Center

ABSTRACT

This paper will discuss in detail the relative navigation system requirements and sensor trade-offs for Automatic Rendezvous and Capture.

Rendezvous navigation filter development will be discussed in the context of navigation performance requirements for a "Phase One" AR&C system capability. Navigation system architectures and the resulting relative navigation performance for both cooperative and uncooperative target vehicles will be assessed. Relative navigation performance using rendezvous radar, star tracker, radiometric, laser and GPS navigation sensors during appropriate phases of the trajectory will be presented. The effect of relative navigation performance on the Integrated AR&C system performance will be addressed. Linear covariance and deterministic simulation results will be used.

Evaluation of relative navigation and IGN&C system performance for several representative relative approach profiles will be presented in order to demonstrate the full range of system capabilities.

The material in this paper is the result of Draper Laboratory involvement with NASA Johnson Space Center in the development of flight proven IGN&C rendezvous systems for Apollo, Skylab and Shuttle. The performance data has been obtained from linear covariance and deterministic analysis simulations. These simulations have also been used to support flight techniques development, definition of performance bounds for flight rules, system performance capability assessment, and to provide signature data for flight software verification.

A summary of the sensor requirements and recommendations for AR&C system capabilities for several programs requiring AR&C will be presented.

Authors:

Peter M. Kachmar

IGN&C Systems Section Head, C.S.Draper Laboratory

555 Technology Square Cambridge, MA. 02139

Phone: 617-258-2431 FAX: 617-565-8674

Robert J. Polutchko

IGN&C Systems Technical Staff, C.S.Draper Laboratory

555 Technology Square Cambridge, MA. 02139

Phone: 617-258-3177 FAX: 617-565-8674

William Chu

IGN&C Systems Technical Staff, C.S.Draper Laboratory

555 Technology Square Cambridge, MA. 02139

Phone: 617-258-2438 FAX: 617-565-8674

Moises M. Montez

Gudance and Navigation Branch Senior Staff

NASA Johnson Space Center Houston, Tx 77058

Phone: 713-483-0460 FAX: 713-483-6134

ABSTRACT

257-18
ABS. ONLY
N93-22277

AUTOMATED RENDEZVOUS AND CAPTURE SYSTEM

P. 3

BY

UNITED TECHNOLOGIES - USBI
AND THE CENTER FOR APPLIED OPTICS
OF THE UNIVERSITY OF ALABAMA, HUNTSVILLE

Author: Jac B. Kader, Senior Engineer, United Technologies/MSFC 4707
(205-544-0869) (Fax 205-544-3152)

Co-Authors: John H. Caulfield, Director - CAO/UAH

Chandra S. Vikram, Research Scientist - CAO/UAH
(205-895-6102)

Steve Patrick, Research Engineer - UT-USBI
(205-721-5573)

For Presentation at the
U.S. AUTOMATED RENDEZVOUS AND CAPTURE
CAPABILITIES REVIEW

NOVEMBER 1991
WILLIAMSBURG, VIRGINIA

Discussion:

AUTOMATED RENDEZVOUS AND CAPTURE - ARC Category 1: Hardware Systems

Statement:

This paper describes an ARC system that is an attempt to simplify operation, reduce energy requirements, reduce weight, and provide longterm use and reliability.

The ARC system is a laser/optical/holographic (LOH) control system for guidance, rendezvous, and docking (RVD).

The LOH/RVD utilizes a hologram, residing at the target platform. Excited by a laser diode, the hologram projects an image at a given distance from the platform. A vision system in the automated chase vehicle sees the projected image and, by optical comparisons, guides the chase vehicle to that image, reaching a proximity conducive to soft docking. The vision system then shifts to a second hologram image holding at close proximity (2mm) to the target platform and guides to it for controlled, precise docking at the rendezvous point.

The holographic image projections from the target platform, are composed of color hues and may be circular, triangular or of any other shape and texture that may enhance the ability of the chase vehicle's vision system to analyze information pertinent to velocity, attitude, and roll of the target platform. Any movement of the image, whether planned or errant, will be translated by the vision system into synchronous adjustments throughout the vehicle approach path.

Maturity:

The LOH/RVD system began conceptual research in 1985 by J.B. Kader. In 1990 the project came under the auspices of United Technologies' USBI and the Center for Applied Optics at the University of Alabama, Huntsville. The optics necessary and the first model of a relevant hologram were developed. The prototype test stand of the LOH/RVD system was assembled, and several successful experiments were conducted.

Test Experience:

Using an image of a cross inside a ring, the test experiment recorded several holograms projected at different distances. These holograms were used to reconstruct images for the chase vehicle as well as the target platform. An HeNe laser (wavelength 632.8 nm) was used for the recording as well as reconstruction at this concept demonstration stage. When observed through a CCD camera (see Figure), the hologram projects two images. When they superimpose, the system becomes perfectly aligned at a pre-determined location. Preliminary observations indicate that holography can be a powerful tool for the recapture and related sensing applications.

DEMONSTRATION (REDUCTION TO PRACTICE)

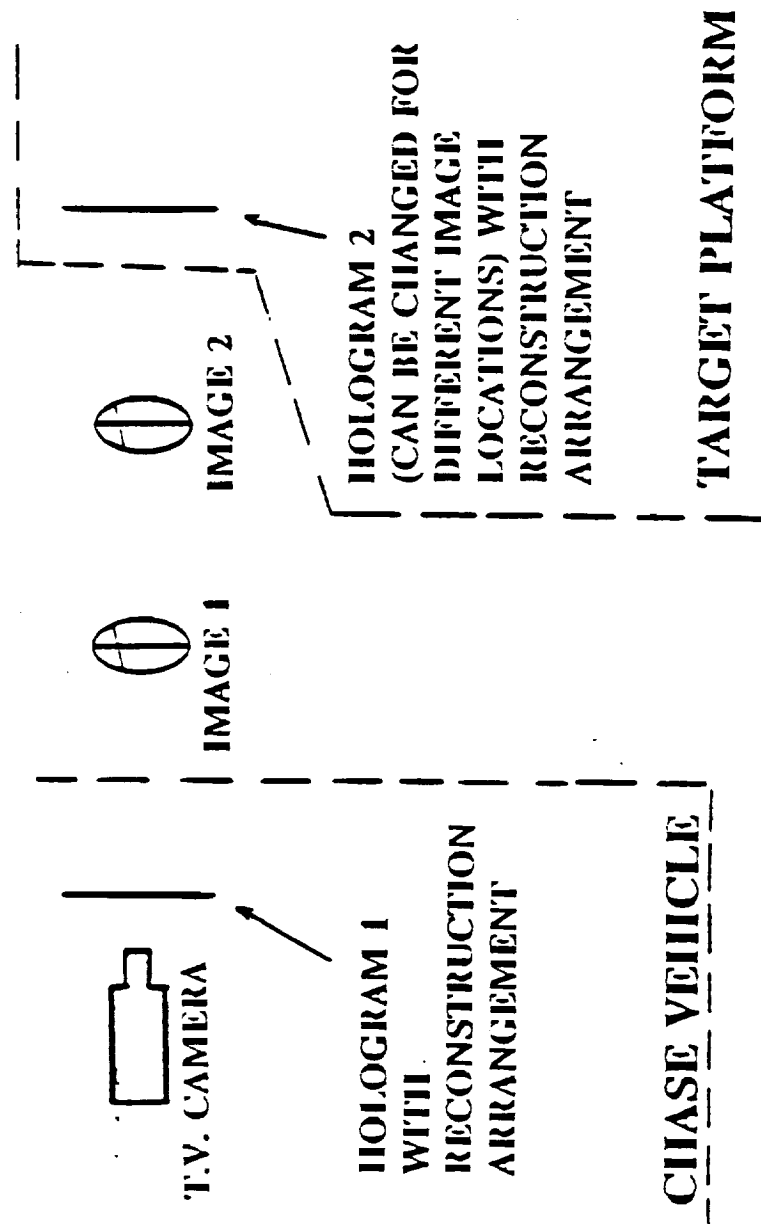

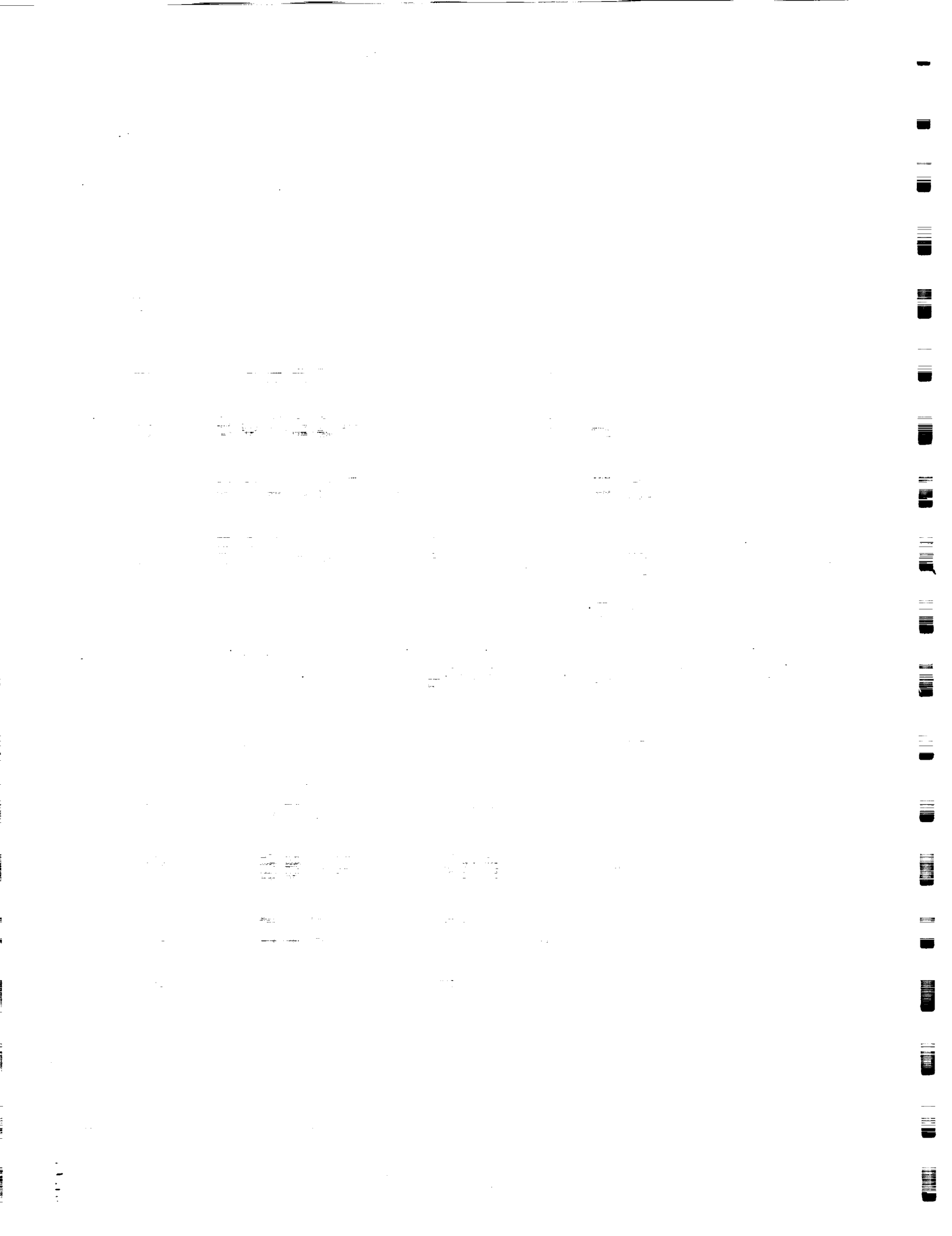

A Comparison Of Laser Based Ranging Systems For AR&C Category I: Hardware

N 93 - 502278
ABS ON27
146762
P - 1

Stephen J. Katzberg and Pleasant W. Goode IV
Information Systems Division/Flight Systems Directorate
NASA-Langley Research Center
(804) 864-8207
FTS 928-8207
NASAMAIL: SJKATZBERG
FAX: (804) 864-8203
FAX: FTS 928-8203

Abstract:

The benefits of incorporating range information in space applications come in several areas. For example, in automatic docking systems range maps are useful to resolve ambiguities in target identification, while for maneuvering, closure and docking in space vehicles, ranging systems are highly useful for quantitative assessment of the proximity environment as well as simple qualitative knowledge for obstacle avoidance, alarm functions, etc. Many optical techniques have been proposed for these applications, with varying degrees of expected performance and effectiveness. With the recent addition of laser-sensor technology to the automation tool-box, very compact and simple robotic sensors are now available.

From the earliest LED/detector combinations to the latest laser radar and fiber optic techniques, electro-optical technology has proven its utility. It is possible, with time-of-flight, TOF, CW-Tone modulated and FM-CW coherent laser radars to measure fractions of a centimeter or less with speeds in the 10's to 100's of samples per second from short to considerable range. However, the practical behavior of these techniques has not always been as good as expected. An analysis of each of these techniques will be given that includes the effects of laser performance on the ability of the systems to perform their ranging function.

This paper will present some aspects of the effect of inherent laser effects on the performance of these two techniques. It will be shown that performance of these techniques is affected in different ways inherent laser characteristics and previous comparisons of the techniques should be modified to reflect more realistic conditions.

An overall survey of laser ranging will be given to place the CW and FM-CW techniques in perspective. It will be seen that the newly introduced FM-CW laser radar has potentially far superior performance to CW-Tone modulated systems now proposed for use in space rendezvous and capture systems.

STATE OF TEXAS
COUNTY OF DALLAS

Know all men by these presents, that _____ of the County of _____ State of _____ do hereby certify that _____ of the County of _____ State of _____ is the true and correct owner of _____

WITNESSETH my hand and seal of office this _____ day of _____ 19____.

Notary Public in and for the State of Texas, My Commission Expires _____

My Comm. Expires _____

My Comm. Expires _____

My Comm. Expires _____

My Comm. Expires _____

My Comm. Expires _____

My Comm. Expires _____

My Comm. Expires _____

My Comm. Expires _____

My Comm. Expires _____

My Comm. Expires _____

My Comm. Expires _____

My Comm. Expires _____

553-61
ABS ONLY
N93-22279 p-4

NEW DEVELOPMENTS IN ASTRODYNAMICS ALGORITHMS FOR AUTONOMOUS RENDEZVOUS

For

U.S. Automated Rendezvous and Capture Capabilities Review
Fort Magruder Inn
Williamsburg, Virginia
1991 November 19-21

By

Allan R. Klumpp*
Jet Propulsion Laboratory
California Institute of Technology
Pasadena, California

At the core of any autonomous rendezvous guidance system must be two algorithms for solving Lambert's and Kepler's problems, the two fundamental problems in classical astrodynamics. Lambert's problem is to determine the trajectory connecting specified initial and terminal position vectors in a specified transfer time. The solution is the initial and terminal velocity vectors. Kepler's problem is to determine the trajectory that stems from a given initial state (position and velocity). The solution is the state at an earlier or later specified time.

To be suitable for flight software, astrodynamics algorithms must be totally reliable, compact, and fast. Although solving Lambert's and Kepler's problems has challenged some of the world's finest minds for over two centuries, only in the last year have algorithms appeared that satisfy all three requirements just stated.

This paper presents an evaluation of the most highly regarded Lambert and Kepler algorithms known to me. One Lambert and one Kepler algorithm are clear winners. All algorithms are available on request on floppy disks or by electronic mail.

Lagrange is credited with deriving the first analytic expression for the Lambert time of flight in 1778. In 1801, Gauss devised a method for solving Lambert's problem and used it to determine the orbit of the planetesimal Ceres from a 3° arc traversed in 41 days. He published solutions for both problems in his *theoria motus* in 1809. Hundreds of solutions have been published; improved methods continue to appear frequently.

* Section Staff, Guidance and Control

The outstanding recent contributions on Lambert's problem came from E. R. Lancaster and R. C. Blanchard¹, and on Kepler's problem from W. H. Goodyear^{2,3}, both in the 1960s. Recently, Robert H. Gooding⁴ of the Royal Aerospace Establishment has made major improvements in the Lancaster-Blanchard algorithm. Francis M. Stienon⁵ of the Jet Propulsion Laboratory has improved the Goodyear algorithm to handle high-energy hyperbolic trajectories, which caused the original Goodyear algorithm to overflow. I have made minor corrections for special cases to Gooding's and Stienon's solutions. The resulting algorithms are equal or superior, in every respect, to all other algorithms evaluated, hence are the clear winners. No cases have been found that the Gooding algorithm will not handle. The Stienon algorithm degrades only for extremely high-energy hyperbolic trajectories, more so for trajectories inbound with respect to the central body than for trajectories outbound (Stienon's original case is essentially outbound).

Other major contributions have been made by Richard H. Battin, his thesis students at the Massachusetts Institute of Technology, and Stanley W. Shepperd of the C. S. Draper Laboratory. Battin and Shepperd⁶ improved the Lancaster-Blanchard algorithm in a number of ways. Most significantly, the Battin-Shepperd algorithm eliminates a singularity for transfer angles that are a multiple of 180° . Battin and Vaughan^{7,8} improved Gauss' 1809 Lambert algorithm so that it converges for virtually all realizable trajectories. Battin and Loechler⁹ extended the Gauss algorithm to handle multiple-orbit transfers, but this extension is not implemented in the algorithm evaluated here because the extension substantially complicates the algorithm. Shepperd¹⁰ developed a universal-variable equivalent of the Goodyear Kepler algorithm. Battin and Fill^{11,12} extended Gauss' 1809 Kepler algorithm to trajectories not necessarily reckoned from periape in which the eccentricity and arc length are arbitrary. Improved versions of these algorithms were published in Battin's 1987 book¹³. I further improved the Battin-Vaughan Lambert algorithm, and extended the Battin-Fill Kepler algorithm to trajectories for which the original did not converge^{14,15,16}.

Unfortunately, each of the algorithms of the preceding paragraph falls short of those by Gooding and Stienon in one or more important ways. The Battin-Shepperd Lambert algorithm is slower than the Gooding algorithm, and less accurate in some extreme cases. The Battin-Vaughan Lambert algorithm requires up to 660 iterations and a great deal of time for minimum-energy orbits approaching 360° transfer angle, whereas the Gooding algorithm handles all single-orbit transfers in five iterations (more precisely, five evaluations of normalized time). Furthermore, the Gooding algorithm is much more compact, and, again, far more accurate in some extreme cases. Shepperd's Kepler algorithm, although slightly faster than Stienon's for more-common trajectories, is much slower and much less accurate for high-energy hyperbolic trajectories. My

extension of the Battin-Fill Kepler algorithm is very robust, but the Stienon algorithm is just as robust, many times faster, and more compact.

REFERENCES

1. E. R. Lancaster and R. C. Blanchard, "A Unified Form of Lambert's Theorem", NASA TN D 5368, Goddard Space Flight Center, Greenbelt, MD, 1969 September.
2. W. H. Goodyear, "Completely General Closed-For Solution for Coordinates and Partial Derivatives of the Two-Body Problem", *The Astronomical Journal*, Vol 70 Number 3, 1965 April.
3. W. H. Goodyear, "A General Method for the Computation of Cartesian Coordinates and Partial Derivatives of the Two-Body Problem", NASA CR-522, prepared under contract No. NAS 5-9762 by International Business Machines Corp., Greenbelt, Maryland, for Goddard Space Flight Center, 1966.
4. R. H. Gooding, "A Procedure for the Solution of Lambert's Orbital Boundary-Value Problem", *Celestial Mechanics and Dynamic Astronomy* 48, 1990.
5. F. M. Stienon, "A Fault in TWOBODY, A Conic State Vector Propagation Subroutine", IOM 314-366, (internal document), 1985 April 12.
6. R. H. Battin, "Lambert's Problem Revisited", *AIAA Journal*, Vol. 15, 1977 May.
7. R. M. Vaughan, "An Improvement of Gauss' Method for Solving Lambert's Problem", Master of Science Thesis, Massachusetts Institute of Technology, 1983 May.
8. R. H. Battin and R. M. Vaughan, "An Elegant Lambert Algorithm", *Journal of Guidance, Control, and Dynamics*, Vol 7 Number 6, 1984 November-December.
9. L. A. Loechler, "An Elegant Lambert Algorithm for Multiple Revolution Orbits", Master of Science Thesis, Massachusetts Institute of Technology, 1988 May.
10. S. W. Shepperd, "Universal Keplerian State Transition Matrix", *Celestial Mechanics* 35, 1985.
11. T. J. Fill, "Extension of Gauss' Method for the Solution of Kepler's Equation", Master of Science Thesis, Massachusetts Institute of Technology, 77 Massachusetts Ave., Cambridge, MAS 02139, 1976 May.

12. R. H. Battin and T. J. Fill, "Extension of Gauss' Method for the Solution of Kepler's Equation", *Journal of Guidance and Control*, 1979 May-June.
13. R. H. Battin, "An Introduction to the Mathematics and Methods of Astrodynamics", American Institute of Aeronautics and Astronautics, Inc., 1633 Broadway, New York, N.Y. 10019, 1987.
14. A. R. Klumpp, "Universal Lambert and Kepler Algorithms for Autonomous Rendezvous", AIAA/AAS Astrodynamics Conference, Portland, Oregon, 1990 August 20-22. Also presented at the Autonomous Rendezvous and Docking Conference, Johnson Space Center, Houston, Texas, 1990 August 15-16.
15. A. R. Klumpp, "An Autopsy of the Extended Gauss Kepler Algorithm", IOM 314.1-0307-ARK, (internal document), 1989 August 23.
16. A. R. Klumpp, "Universal Lambert and Kepler Procedures in Ada", JPL D-7470, (internal document), 1990 June.

Version of 91 Sep 24 11:49 PST

Onboard Navigation Rendezvous Expert System

Michele Kocen, Rockwell Space Operations Company
600 Gemini, Houston, TX 77058
(713) 282-3271, Fax (713) 282-4575

554-13
NBS ONLY
1462164
N 93-22280
p

The Onboard Navigation rendezvous expert system is designed to aid the ground flight controller in monitoring the shuttle onboard navigation system. The system is designed to keep track of the navigation sensors and relative state vectors. In addition, the system also keeps an event log and fills out forms usually handled by the flight controller. This expert system is one of the few rendezvous specific systems being developed for the Mission Control Center.

The expert system has been in development for six years. Through these years the system has seen hardware, software, and personnel changes. Initial development was done by the Information Systems Directorate (ISD) and Mission Operations Directorate (MOD) at Johnson Space Center. As of October 1, 1991 the system has been turned over to MOD.

The system is completely developed except for some minor adjustments to the user interface. The rule base is in the verification stage with total certification of the system due to be completed by May 1992.

Test cases for verification are obtained by saving data used for flight controller integrated simulations. The actual data comes from both the shuttle mission simulator and the Mission Control Center Computer. So far no actual flight data has been available.

This paper covers all aspects of the system from the development history to the current hardware, software, and use of the system.

The first part of the document discusses the importance of maintaining accurate records of all transactions. It emphasizes that every entry should be supported by a valid receipt or invoice. This ensures transparency and allows for easy verification of the data.

In the second section, the author outlines the various methods used to collect and analyze the data. This includes both manual and automated processes. The goal is to ensure that the data is as accurate and reliable as possible.

The third part of the document provides a detailed breakdown of the results. It shows that there has been a significant increase in sales over the period covered. This is attributed to several factors, including improved marketing strategies and better customer service.

Finally, the document concludes with a series of recommendations for future actions. These include continuing to invest in marketing, improving operational efficiency, and maintaining the high standards of data accuracy that have been established.



U.S. Automated Rendezvous and Capture Capabilities Review
Introduction to General Dynamics Presentations

555-13
N93-22281
PR5 ONLY
146765
P-2

Abstract Title: An Overview of Autonomous Rendezvous and Docking System Technology Development at General Dynamics

Author: Fred Kuenzel

Affiliation: Director of Avionics
General Dynamics, Space Systems Division
P.O. Box 85990, San Diego, Ca. 92186-5990
MZ 24-8630

Overview Summary:

This short overview should precede the General Dynamics briefings chosen for presentation. It will last about 15 minutes, use several pictures and eliminate the need for the following General Dynamics presentors to cover the same historical aspects of their programs.

Historical Background:

The Centaur avionics suite is undergoing a dramatic modernization for the commercial, DoD Atlas and Titan programs. The system has been upgraded to the current state-of-the-art in ring laser gyro inertial sensors and Mil-Std-1750A processor technology. The Cruise Missile avionic system has similarly been evolving for many years. Integration of GPS into both systems has been underway for over five years with a follow-on cruise missile system currently in flight test. Rendezvous and Docking related studies have been conducted for over five years in support of OMV, CTV, and Advanced Upper Stages, as well as several other internal IR&Ds. The avionics system and AR&D simulator demonstrated to the SATWG in November of 1990 has been upgraded considerably under two IR&D programs in 1991.

Test Experience:

The Centaur modern avionics system is being flown in block upgrades which started in July of 1990. The Inertial Navigation Unit will fly in November of 1991. The Cruise Missile avionics systems have been fully tested and operationally validated in combat. The integrated AR&D system for space vehicle applications has been under development and testing since 1990. A Joint NASA / GD ARD&L System Test Program is currently being planned to validate several aspects of system performance in three different NASA test facilities in 1992.

Sponsorship and Funding:

Currently, the development of the integrated rendezvous and docking system is being pursued on IR&D funding from the Space Systems, Convair and Electronics divisions. General Dynamics is working with Johnson Space Center, Marshall Space Flight Center, and Langley Research Center in a cooperative test and demonstration effort. This multi-center program combines the expertise and testing capabilities to establish and validate a performance baseline for autonomous rendezvous, docking and landing systems.

56 13

ABS ONLY

N93-22282

146766

P, 2

ABSTRACT

U. S. AUTOMATED RENDEZVOUS AND CAPTURE CAPABILITIES REVIEW

TITLE: AUTONOMOUS DOCKING GROUND DEMONSTRATION (Category 3)

AUTHORS NAMES:

- o S. L. LAMKIN; JSC/EG; Phone: 713-483-6284; FAX 713-483-6134; Electronic Mail ID: LAMKIN_STEVE (All-in One)
- o R. E. EICK; TRW Houston; Phone: 713-333-3133; FAX: 713-333-1875; Electronic Mail ID: EICK_RICHARD (All-in-One)
- o J. M. BAXTER; TRW Houston; Phone: 713-333-3133; FAX: 713-333-1875; Electronic Mail ID: BAXTER_JIM (All-in-One)
- o M. G. BOYD; LESC/C62; Phone: 713-483-7708; FAX: 713-483-2162; Electronic Mail ID: (Paper Mail)
- o F. D. CLARK; LESC/C87; Phone: 713-333-6284; FAX: 713-333-6908; Electronic Mail ID: CLARK_FRED@A1@LOCK (All-in-One)
- o T. Q. LEE; JSC/EG; Phone: 713-483-8304; FAX: 713-483-6134; Electronic Mail ID: LE_THOMAS (All-in-One)
- o L. T. OTHON; JSC/ES; Phone: 713-483-6396; FAX: 713-483-5196; Electronic Mail ID: (Paper Mail)
- o J. L. PRATHER; JSC/EE; Phone: 713-438-1483; FAX: 713-483-5830; Electronic Mail ID: PRATHER_JOSEPH@A1@TCD (All-in-One)
- o P. T. SPEHAR; LESC/C87; Phone: 713-333-6540; FAX: 713-333-6908; Electronic Mail ID: SPEHAR_PETE@A1@LOCK (All-in-One)
- o R. J. TEDERS; LESC/B14; Phone: 713-333-6380; FAX: 713-333-8038; Electronic Mail ID: TEDERS_REBECCA@A1@LOCK (All-in-One)

TECHNICAL DESCRIPTION

The NASA Johnson Space Center (JSC) is involved in the development of an autonomous docking ground demonstration. The demonstration combines the technologies, expertise and facilities of the JSC Tracking and Communications Division (EE), Structures and Mechanics Division (ES), and the Navigation, Guidance and Control Division (EG) and their supporting contractors.

U. S. Automated Rendezvous and Capture Capabilities Review - Abstract
9/26/91

The autonomous docking ground demonstration is an evaluation of the capabilities of the laser sensor system to support the docking phase (12ft to contact) when operated in conjunction with the Guidance, Navigation and Control software . The docking mechanism being used was developed for the Apollo Soyuz Test Program. This demonstration will be conducted using the Six-Degrees of Freedom (6-DOF) Dynamic Test System (DTS). The DTS environment simulates the Space Station Freedom as the stationary or target vehicle and the Orbiter as the active or chase vehicle. For this demonstration the laser sensor will be mounted on the target vehicle and the retroreflectors on the chase vehicle. This arrangement was used to prevent potential damage to the laser. The sensor system, GN&C and 6-DOF DTS will be operated closed-loop. Initial condition to simulate vehicle misalignments, translational and rotational, will be introduced within the constraints of the systems involved.

Detailed description of each of the demonstration components (e.g. Sensor System, GN&C, 6-DOF DTS and supporting computer configuration) including their capabilities and limitations will be discussed. A demonstration architecture drawing and photographs of the test configuration will be presented.

The test runs are tentatively scheduled to be conducted in late October-early November 1991. If this occurs, videos of the demonstrations and preliminary results will be presented.

TEST EXPERIENCE/RESULTS:

The sensor system being used is a brassboard version of the laser docking sensor that was being developed for application in the Lunar/Mars programs. The laser system being used has been tested in the Six-DOF Sensor Test Bed (granite rail) in Building 14 at NASA/JSC. The results of these tests will be presented. Further laser docking system development is not presently funded.

SOURCE/SPONSORSHIP AND CURRENT FUNDING:

Funding for this ground demonstration was provided as Research and Technology Operating Project (RTOP) funding by NASA Headquarters, Code R. Funding for FY92 is not planned.

507-32
ARS ONLY

146267
N93-22,283

Abstract Title:
Rendezvous Radar for the Orbital Maneuvering Vehicle

Authors' Names:
John W. Locke, Keith Olds and Howard Parks

Affiliation:
Motorola Inc., Strategic Electronics Division

Phone #: 602-732-4057 and 602-732-3018
FAX #: 602-732-2148

This paper describes the development of the Rendezvous Radar Set (RRS) for the Orbital Maneuvering Vehicle (OMV) for the National Aeronautics and Space Administration (NASA). The RRS was to be used to locate, and then provide vectoring information to, target satellites (or Shuttle or Space Station) to aid the OMV in making a minimum-fuel-consumption approach and rendezvous. The RRS design is that of an X-Band, all solid-state, monopulse tracking, frequency-hopping, pulse-Doppler radar system. The development of the radar was terminated when the OMV prime contract to TRW was terminated by NASA. At the time of the termination, the development was in the circuit design stage. The system design was virtually completed, the PDR had been held.

The RRS design was based on Motorola's experiences, both in the design and production of radar systems for the US Army and in the design and production of hi-rel communications systems for NASA space programs. Experience in these fields was combined with the latest digital signal processor and micro-processor technology to design a light-weight, low-power, spaceborne radar. The antenna and antenna positioner (gimbals) technology developed for the RRS is now being used in the satellite-to-satellite communication link design for Motorola's Iridium™ telecommunications system.

The RRS design effort was sponsored by NASA via TRW, the OMV prime contractor.

1950

1. The first part of the report deals with the general situation of the country and the progress of the work during the year. It is divided into two main sections: the first section deals with the general situation and the second section deals with the progress of the work.

2. The second part of the report deals with the results of the work during the year. It is divided into two main sections: the first section deals with the results of the work in the field of research and the second section deals with the results of the work in the field of administration.

3. The third part of the report deals with the financial situation of the organization during the year. It is divided into two main sections: the first section deals with the income and the second section deals with the expenditure.

4. The fourth part of the report deals with the personnel situation of the organization during the year. It is divided into two main sections: the first section deals with the recruitment and the second section deals with the promotion.

5. The fifth part of the report deals with the general conclusions and recommendations of the organization during the year. It is divided into two main sections: the first section deals with the general conclusions and the second section deals with the recommendations.

6. The sixth part of the report deals with the general remarks of the organization during the year. It is divided into two main sections: the first section deals with the general remarks and the second section deals with the general remarks.

7. The seventh part of the report deals with the general remarks of the organization during the year. It is divided into two main sections: the first section deals with the general remarks and the second section deals with the general remarks.

8. The eighth part of the report deals with the general remarks of the organization during the year. It is divided into two main sections: the first section deals with the general remarks and the second section deals with the general remarks.

558-13
146768

N 9 3 - 2 2 2 8 4

**AUTONOMOUS RENDEZVOUS TARGETING TECHNIQUES
FOR NATIONAL LAUNCH SYSTEM APPLICATION**

James J. Lomas
and
A. Wayne Deaton
NASA Marshall Space Flight Center

ABSTRACT

This paper describes the rendezvous targeting techniques that can be utilized to achieve autonomous guidance for delivering a cargo to Space Station Freedom (SSF) using the National Launch System's (NLS) Heavy Lift Launch Vehicle (HLLV) and the on-orbit Cargo Transfer Vehicle (CTV). This capability is made possible by advancements in autonomous navigation (Global Positioning System - GPS) on-board the CTV and SSF as well as the new generation flight computers.

This paper describes how the HLLV launch window can be decoupled from the CTV phasing window. The performance trades that have to be made to determine the length of the launch window and the phasing window between the CTV and SSF are identified and recommendations made that affect mission timelines.

1948

1949

1950

1951

1952

1953

1954

1955

1956

1957

1958

1959

1960

1961

1962

1963

Intelligent Systems Technology Infrastructure for Integrated Systems

Dr. Henry Lum, Jr.
NASA Ames Research Center
(415) 604-6544
Fax: (415) 604-6997
NASAmail Address: HLUM

559-93
N93-22285
196-169
P-3

Significant advances have occurred during the last decade in intelligent systems technologies (a.k.a. knowledge-based systems, KBS) including research, feasibility demonstrations, and technology implementations in operational environments. Evaluation and simulation data obtained to date in real-time operational environments suggest that cost-effective utilization of intelligent systems technologies can be realized for Automated Rendezvous and Capture applications. The successful implementation of these technologies involve a complex system infrastructure integrating the requirements of transportation, vehicle checkout and health management, and communication systems without compromise to systems reliability and performance.

The resources that must be invoked to accomplish these tasks include remote ground operations and control, built-in system fault management and control, and intelligent robotics. To ensure long-term evolution and integration of new validated technologies over the lifetime of the vehicle, system interfaces must also be addressed and integrated into the overall system interface requirements. An approach for defining and evaluating the system infrastructures including the testbed currently being used to support the on-going evaluations for the evolutionary Space Station Freedom Data Management System will be presented and discussed. Intelligent system technologies to be discussed include artificial intelligence (real-time replanning and scheduling), high performance computational elements (parallel processors, photonic processors, and neural networks), real-time fault management and control, and system software development tools for rapid prototyping capabilities. Generic applications of these technologies are focused on distributed, real-time avionics architectures; avionics software capable of autonomous operations for long duration periods; vehicle health management and control (including reconfiguration); and, advanced landing and recovery systems. Examples of each of the on-

going efforts in these technology areas/applications will be discussed with the current application status.

The on-site supporting testbeds have been developed to support the sponsored efforts for Space Station Freedom, OAET (AI, Data Systems, Photonics), OAET/OSF Strategic Avionics Technology Program, and the Defense Advanced Research Projects Agency (DARPA). The Automation Sciences Research Facility (ASRF), a 60,000 laboratory dedicated to the development of intelligent systems technologies, recently became operational in October 1991 and provides the laboratory and research environments for the technology efforts described above. In addition, the ASRF is integrated with the Human Performance Research Laboratory (HPRL) to provide an integrated research environment to address the human's interaction/interface with highly automated systems and the merger of intelligent systems technologies with "conventional" technologies. The configuration/status/capability of the individual technology testbeds as well as the integrated ASRF/HPRL testbed will be described. Specific technology deliverables and system demonstrations conducted in operational environments to demonstrate the cost-effectiveness of the technology implementations will be discussed. Examples of fielded technology demonstrations to be discussed include Constrained-based Scheduling for Space Shuttle, Automated Thermal Control System for Space Station Freedom, and Real-time Fault Management and Control for the F-18. Aerospace contractors such as IBM, Rockwell, Lockheed, and McDonnell Douglas have expressed an interest in using the testbed capabilities resident at Ames when they become operational during early CY-92 for "external" utilization.

Personnel within the Division supporting the above efforts number approximately 120 researchers. The AI research group is among the best in the United States with international recognition and acceptance. The computational sciences research group is rapidly gaining international recognition and has released significant software tools to the NASA, academic, and industrial communities. Significant technology software products have been delivered both to the NASA operational centers and to the aerospace industry for use and evaluation in aerospace mission applications. Typical examples of these deliverables and the cost benefits obtained from each will be described.

Funding to support the current research efforts including the demonstration efforts and the rapid prototyping capabilities are provided by the following sources: OAET, Code RC; OSF, Codes MT and MD; O SSA, Code SE; and, the Defense Advanced Research Projects Agency (DARPA). Annual funding from these sources exceed \$15M per year.

U.S. Automated Rendezvous and Capture Capabilities Review
Category 1 - Hardware Systems

580-18
N 93-22286
1153-22286
146770
p. 1

Abstract Title: DGPS For Space And Return
Author: Stanley C. Maki
Affiliation: General Dynamics, Space Systems Division
P.O. Box 85990, San Diego, Ca. 92186-5990
MZ 24-8710
(619) 547-5364
(619) 974-4000 (FAX)

Technical Details:

A different type of differential GPS (DGPS) configuration is described and compared to the standard DGPS configuration.

Implementation options for either configuration for space and return are discussed.

Historical Background:

DGPS has been studied by numerous organizations as a highly sought after accuracy improvement to standard GPS, particularly with selective availability applied. Flight tests of DGPS have been conducted by NASA LaRC and NASA JSC.

Technology Maturity:

This is a first look at a different type of DGPS configuration. Promising analysis results should be followed up with experimental field testing. Implementation options will address use of current and near term technology.

Sponsorship and Funding:

Currently, the development of the DGPS For Space And Return is being pursued on IR&D funding.

Biography:

Stanley C. Maki, as Advanced Avionics senior engineering specialist, is performing studies pertaining to low-cost application of the Global Positioning System (GPS)/Inertial Navigation System to space boosters. He was responsible for the Orbital Transfer Vehicle (OTV) avionics predesign with GPS application; more recently, he has been involved in Centaur GPS experiments and system analysis for the Multi-Path Redundant Avionics Suite (MPRAS) study, including a GPS element. Mr. Maki has been continuously engaged in space vehicle guidance and control since 1956, starting with design of the first space-flown solid-state digital flight sequencer for the Atlas intercontinental ballistic missile. He has a BSEE from the University of Minnesota and an MS in Engineering from the University of California at Los Angeles.

Faint, illegible text, possibly bleed-through from the reverse side of the page. The text is arranged in several paragraphs and is mostly centered on the page.



561-18

N 93 - 22287

146721

P-3

ABSTRACT

AN AUTOMATED RENDEZVOUS & CAPTURE SYSTEM DESIGN CONCEPT FOR THE CARGO TRANSFER VEHICLE AND SPACE STATION FREEDOM

BY

R. FUCHS AND S. MARSH
LOCKHEED MISSILES AND SPACE COMPANY

A rendezvous sensor system concept was developed for the CTV to autonomously rendezvous with and be captured by SSF. This paper describes the development of requirements, the design of a unique Lockheed developed sensor concept to meet these requirements and the system design to place this sensor on the CTV and rendezvous with the SSF.

The system design is based upon the CTV mission scenario guidelines which are currently being defined by Marshall Space Flight Center. The guidelines are a product of study contracts let by MSFC to establish specifications for the National Launch System, NLS. The system design concept also meets the preliminary Avionics System Requirements which are a product of the same MSFC study contracts. These requirements include the safety aspects of man-rating (for operation near and while attached to the SSF).

These evolving scenarios under the development direction of MSFC for rendezvous of the CTV with SSF include six modes: 1. rendezvous phasing of the CTV to catch up with SSF; 2. injection to a stable orbit point at 20nm from the SSF; 3. transfer to a stable orbit point 1nm from the SSF; 4. transfer to a stable orbit point at 1000 ft from the SSF; 5. proximity operations, approach from 1000ft to a capture area; and 6. manual grappling with the SSF ARM to capture and berth (attach) the CTV to the SSF.

The classic system design process was applied: flow down of the mission scenario guidelines and NLS requirements to establish the rendezvous sensor requirements. These sensor requirements were derived by taking advantage of measurements that are available from other sources, such as prelaunch SSF position data provided to the CTV, and guidance and navigation instruments planned for the CTV to meet other requirements. This reduced the range requirement on the rendezvous sensor from acquiring at the initial orbit injection point which is 20,000 km away from SSF. The CTV has Global Positioning System, GPS, for navigation. The baseline SSF does not have GPS. However, since GPS may be added to SSF, a second set of requirements were developed for this possibility. These two sets of assumptions produced two very different sets of requirements for the automated rendezvous and capture, AR&C, sensor. The baseline set requires a sensor that has a range of 56 nm, whereas the second assumption (GPS on SSF) only requires that the sensor have a range of 1nm. This large difference is due to the large uncertainty in the SSF position, 36nm, without GPS, compared to 30 meters with GPS. In both cases the sensor must provide measurements to the capture area, near 0 distance. In addition to range other measurements are required: range rate, and bearing angle. Relative attitude measurement is not required for capture as it is for

docking. The accuracy of all measurements was established by analysis and confirmed by simulation.

Previous approaches have met the large operating range requirement with the use of two or more devices, e.g. microwave radar for long range and visual imaging for close in. However, this requires that the long range sensor hand over to the close in sensor at a possibly dangerous point in the mission scenario. To avoid this problem we were interested in determining if a single sensor concept could be used over the entire range(s) for safety and simplicity. Sensor concepts that are applicable are described in references 1. and 2., but none appeared to meet our single sensor requirement over the large dynamic range with a simple design. The solution was found in a Lockheed developed measurement device that is based on laser interferometry and employs modulated optical phase. This device was built and tested under contract to SDIO for an application that is different than rendezvous (measurement of mirror flatness). When we applied the concept to designs to meet the sensor specifications we found that they could be met with reasonable design parameters. We had to invent techniques for obtaining range, bearing, and range rate and relative attitude. From these techniques the design parameters of the sensor were defined such as: laser power, laser broadcast solid angle, detector performance (NEP) to meet the two sets of system requirements. The electronic filtering and processing were similar to the original SDIO developed sensor, but with fewer channels. The processing power for this application was determined. It proved to be quite small, ~ 2 k flops which is less than 1% of a typical space computer capacity. In summary the sensor was found to have the following advantages: simple mechanical design(no moving parts) ,simple electronic design ,high accuracy(not effected by signal amplitude), large dynamic range(operates from acquisition to capture), low processing power, high noise rejection, and low laser power.

The technical risk of this concept is very low. The concept we selected exploits technology developed under SDIO and requires no additional technology innovations. It employs a relatively straight forward projection and detection of a modulated interferometry pattern to accuracies well within the SOA.

Three implementation architectures were defined. The first places the lasers on the CTV and a passive target board with retroreflectors on the SSF that send the signals back to the CTV where they are detected and processed. The second architecture places the laser on the SSF and the detectors and processing on the CTV. The third has the laser on the CTV and the detectors on the SSF. The SSF processes the signal and sends control commands to the CTV. The latter two concepts provide a built in passive collision avoidance capability. Lack or loss of commands or laser signals would abort the rendezvous.

The integration of the sensor with the CTV was defined and analyzed. Integration analysis performed was with structure (physical location and boresight direction for the signal laser and FOV's of the detectors), attitude control system, and the reaction control system. The CTV attitude reference was switched from local horizontal to SSF oriented at the 1nm point. A comparison was made for three different "final" approaches, V-bar, R-bar and Constant Bearing. The variation of

propellant usage with approach angle is quantified. The inherent safety of each approach is compared in the event of need to abort. The optimum CTV /Payload carrier vehicle orientation during the final approach is also determined for several sets of RCS thruster configurations.

The system design, analysis and simulation of the described system was developed initially by Lockheed using discretionary funds ,and is currently partially funded as part of MSFC 's National Launch System system definition study contract . The development of optical phase measurement was performed under contract to SDIO. The application of modulated optical phase to the specific designs to meet CTV/ SSF rendezvous requirements, and CTV integration was accomplished entirely with LMSC discretionary funds.

-
1. Rendezvous and Capture of Station Keeping Platform, JPL , IOM 343-89-030, R. Van Bezooijen
 2. Sensor Trade Study, Vol 1: Autonomous Rendezvous and Docking, JSC, 216900-8-F1

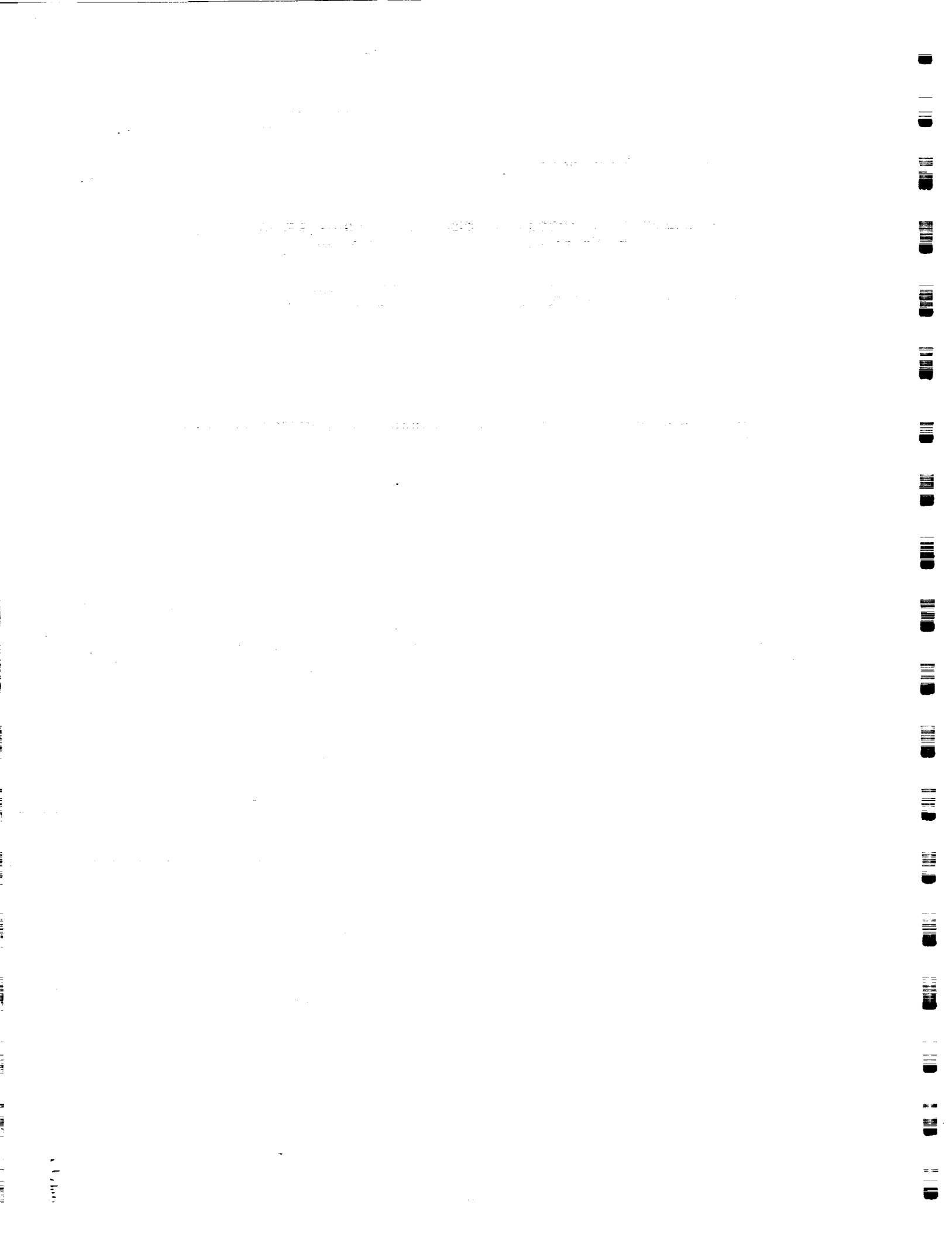

SUPERVISED AUTONOMOUS RENDEZVOUS AND DOCKING SYSTEMS

TECHNOLOGY EVALUATIONS*

Neville I. Marzwell
 NASA/ Jet Propulsion Laboratory
 California Institute of Technology
 4800 Oak Grove Drive, Pasadena, California
 (818) 354- 6543

S-62-18

ABS. ONLY

146772

P-1

ABSTRACT

The Jet Propulsion Laboratory, employing the technology assessment that resulted from the "Autonomous Rendezvous and Docking Conference" held at the Lyndon B. Johnson Space Center (Aug15-16, 1990) as the basis undertook a literature search and contacts with major national and international aerospace companies to perform an assessment of the existing technologies and those that are needed to accomplish supervised autonomous rendezvous and docking in space.

The presentation will cover five issues: a) Lessons Learned, b) Technology assessment for navigation and guidance sensors for Autonomous Rendezvous and Docking (AR&D), c) Technology assessment of Guidance, Navigation and Controls (GN&C) techniques for rendezvous and docking, d) Docking mechanisms and e) Space and Ground Operations.

Although concepts for rendezvous and docking sensors, architecture, protocol and mechanism exist, the choices of demonstrated capabilities are limited. The trade analysis of software and hardware leaves a lot to be desired because of inconsistency in the data base and the simulation efforts. Current mechanism designs are targetted to manned-module docking. There is a need to achieve soft docking of a wide range of free-flying spacecraft and space-borne devices and assemblies. The need for autonomous docking has identified the need, in particular, for closer system integration of sensors and control software to make the mechanism respond to real-time relative displacement, body interactive dynamics and rate data. Neural Network offers tremendous potential for true autonomy but the technology capability need to be verified.

* This work was funded by the New Initiative Office at the Johnson Space Center (Task No. 906-00-00).

1. The first part of the document discusses the importance of maintaining accurate records of all transactions.

2. It is essential to ensure that all data is entered correctly and consistently across all systems.

3. Regular audits should be conducted to verify the accuracy and integrity of the information.

4. The second section covers the various methods used to collect and analyze data.

5. These methods include surveys, interviews, and focus groups, each with its own strengths and limitations.

6. The choice of method depends on the specific research objectives and the nature of the data being collected.

7. It is important to select the most appropriate method to ensure the reliability and validity of the results.

8. The third part of the document addresses the challenges associated with data collection and analysis.

9. These challenges include issues such as data quality, response rates, and the complexity of the data.

10. Strategies are provided to overcome these challenges and ensure the success of the research project.

11. The final section discusses the importance of ethical considerations in research.

12. Researchers must adhere to strict ethical guidelines to protect the rights and privacy of their participants.

563-11
ABS. ONLY

N 93-22289

P-2

A Navigation and Control System for an Autonomous Rescue Vehicle
in the Space Station Environment

Lawrence Merkel

Intelligent Systems Department, C19
Lockheed Engineering and Sciences Co.
2400 NASA Road 1
Houston, Texas 77058
(713) 333-6800

Abstract

A navigation and control system was designed and implemented for an orbital autonomous rescue vehicle envisioned to retrieve astronauts or equipment in the case that they become disengaged from the space station. The rescue vehicle, termed the Extra-Vehicular Activity Retriever (EVAR), has an on-board inertial measurement unit and GPS receivers for self state estimation, a laser range imager (LRI) and cameras for object state estimation, and a data link for reception of space station state information. The states of the retriever and objects (obstacles and the target object) are estimated by inertial state propagation which is corrected via measurements from the GPS, the LRI system, or the camera system. Kalman filters are utilized to perform sensor fusion and estimate the state propagation errors.

Control actuation is performed by a Manned Maneuvering Unit (MMU). Phase plane control techniques are used to control the rotational and translational state of the retriever. The translational controller provides station-keeping or motion along either Clohessy-Wiltshire trajectories or straight line trajectories in the LVLH frame of any sufficiently observed object or of the space station.

The software has been used to successfully control a prototype EVAR on an air bearing floor facility, and a simulated EVAR operating in a simulated orbital environment. The design of the navigation system and the control system are presented. Also discussed are the hardware systems and the overall software architecture.

Background

There exists during EVA operations the potential for an EVA crewperson or piece of equipment to separate from the Space Station. It was determined that a significant probability would exist for the loss of a crewperson(s) if a retrieval by a crewperson were attempted. The EVA Retriever is conceived as an autonomous vehicle which could perform the retrieval task, avoiding risk to a crewperson. The EVAR incorporates various capabilities including task scheduling, world modeling, path planning, and image processing. A navigation and control system capable of performing the necessary maneuvers is required.

Current Status

The core of the navigation and control system has been designed, implemented, and tested. Further development will be towards more sophisticated measurement noise models (utilized by the Kalman filters) for phenomena such as range effects on the LRI accuracy and unmeasured plume impingements effects, namely on the target object. Additional development will be towards reducing propellant consumption by performing simultaneous translational and rotational accelerations when feasible.

Test Experience

The software has been used to successfully control a prototype EVAR on an air bearing floor facility (at Johnson Space Center, Houston). The software has also been used to successfully control a simulated EVAR operating in a simulated orbital environment including modeled sensor errors and plume impingement effects.

Funding

The work was performed under NASA contracts NAS 9-15800 and NAS 9-17900.

ABSTRACT

064-74
ABS. ONLY
N 93 - 22290
p. - 2

OPTICAL PHASE MEASURING SENSORS
FOR AUTOMATED RENDEZVOUS AND CAPTURE
BY
W. METHENY & M. MALIN
LOCKHEED MISSILES AND SPACE COMPANY

A technique is described for sensing relative spatial orientations of approach and target vehicles, using optical phase mensuration (in the interferometric sense, as opposed to LIDAR), in place of the more conventional intensity, image, or transit time measurements. This approach permits the parameters to be measured with great accuracy with relatively simple, small sensors having no moving components. A suite of sensors operating on this principle can produce all desired data using either active detection on the target or passive retroreflection to the detectors on the approach vehicle.

These optical phase measurements can be applied to determine bearing angle (location of the target vehicle in the approach vehicle coordinates), range, and attitude (orientation of the target vehicle with respect to the line-of-sight). The first two quantities require the approach vehicle to project a modulated interference pattern into space. The bearing angle is determined for a selected point on the target by measuring the phase of the interference pattern at that point using either a detector on the target or a retroreflector on the target and a detector at the transmitter. The range is found by measuring differential bearing angles to predetermined relative instrumentation sites. Two interferometers, a coarse and a fine ranger are required to resolve the 2π ambiguity.

Determination of the attitude requires two interferometers (one each for pitch and yaw) to be mounted on the target vehicle. The approach vehicle projects a laser beam (with the modulation imposed on one polarization) instead of a fringe pattern with the interference generated with the same technique, only at the target. Once again, detection can be done either locally or back at the transmitter via retroreflection.

The interferometers themselves are of a simple design using birefringent Savart plates. They depend on photoelastic modulation of one polarization state to extract the phase of the signal using Fourier analysis of the detected radiation. This technique was initially developed under the Monocle Relay Mirror Control Concepts and Technology Demonstration Program (USASDC

contract DASG60-85-C-0024) to serve as the figure sensor for a large space based relay mirror. It was implemented as a set of grazing incidence interferometers with 40mm diameter optics and thoroughly tested in a series of experiments in vacuo. The phases of the measured wavefronts were determined to accuracies in excess of 1 part in 2000.

Wayne Metheny, o/97-30
Lockheed Missiles & Space Company
3251 Hanover Street
Palo Alto, CA 94304-1187
(415) 424-2111
FAX: (415) 354-5400

Mark Malin, o/66-01
Lockheed Missiles & Space Company
1111 Lockheed Way
Sunnyvale, CA 94089
(408) 756-4514
FAX: (408) 742-5008

-65-19

ABS: ONLY

146775

MAGNETIC END EFFECTORS FOR SPACE OPERATIONS

Leo Monford,
Lyndon B. Johnson Space Center

N 93 - 22291

Edward L. Carter,
Lockheed Engineering & Sciences Company
Houston, TX

The Magnetic End Effector (MEE) to be flown as part of the Dexterous End Effector (DEE) flight experiment has been designed to operate with the Shuttle Remote Manipulator System (SRMS). Grappling or attachment of payloads is accomplished magnetically with two fault tolerant operation. The small magnetic grapple plate weighs far less than the standard grapple fixture; allows stacking and close spacing of payloads and eliminates secondary release mechanisms. In addition to specifics regarding the MEE, the DEE project, Magnetic Attachment Tool (MAT), RMS-Force Torque Sensor (RMS-FTS) and Targeting and Reflective Alignment Concept (TRAC) will be discussed.

The first part of the document discusses the importance of maintaining accurate records of all transactions. It emphasizes that every entry should be supported by a valid receipt or invoice. This ensures transparency and allows for easy verification of the data.

In the second section, the author details the various methods used to collect and analyze the data. This includes both manual and automated processes. The goal is to ensure that the data is as accurate and reliable as possible.

The final part of the document provides a summary of the findings and conclusions. It highlights the key trends and insights that were discovered during the analysis. The author also offers some recommendations for future work and improvements.



566-13
N 93 - 22202

**Use of Automated Rendezvous Trajectory Planning
to Improve Spacecraft Operations Efficiency**

146776
P 3

by

Tom A. Mulder
McDonnell Douglas Space Systems Company – Houston Division
16055 Space Center Blvd.
Houston, Texas 77062-6208
(713) 283-4315
Fax # (713) 283-4020

Abstract

The current planning process for space shuttle rendezvous with a second Earth-orbiting vehicle is time consuming and costly. It is a labor-intensive, manual process performed pre-mission with the aid of specialized maneuver processing tools. Real-time execution of a rendezvous plan must closely follow a predicted trajectory, and targeted solutions leading up to the terminal phase are computed on the ground. Despite over 25 years of Gemini, Apollo, Skylab, and shuttle vehicle-to-vehicle rendezvous missions flown to date, rendezvous in Earth orbit still requires careful monitoring and cannot be taken for granted. For example, a significant trajectory offset was experienced during terminal phase rendezvous of the STS-32 Long Duration Exposure Facility retrieval mission.

Rendezvous of an unmanned spacecraft with Space Station Freedom (SSF) during permanently-manned operations will become a routine activity, occurring with greater frequency than rendezvous flights currently performed by the space shuttle. The current shuttle rendezvous process from conceptual mission design to real-time target vehicle grapple carries too high a price for repetition over the lifetime of the SSF. The bulk of this bill is paid during many months of preflight rendezvous trajectory analysis before the shuttle ever leaves the ground. Several improvements can be introduced to the present rendezvous planning process to reduce these costs, produce more fuel-efficient profiles, and increase the probability of mission success.

Realization of the above benefits requires incorporation of an automated or autonomous rendezvous and docking capability. Several organizations are presently developing sensors, mechanisms, and algorithms to aid in the execution of pre-computed rendezvous plans. However, a sometimes-overlooked effort is needed for reduction of the manpower necessary to generate the optimum maneuver plans—especially real-time trajectory replanning based on unforeseen problems and dispersions.

The Rendezvous/Proximity Operations Trajectory Control Expert System (RENEX), the Expert First Guess component of the Expert Flight Analysis System (XFAS), and the rendezvous planning segment of the Autonomous Operations (AUTOPS) project were NASA/JSC attempts at reducing the flight design effort through use of expert systems. These concepts engaged predefined rules that applied to orbital situations for "catching up" or "falling back" to the target vehicle. The Autonomous Rendezvous Planner (ARP), under development at McDonnell Douglas for the Navigation, Control, and Aeronautics Division of the Engineering Directorate at NASA/JSC, however, steps beyond this approach by producing a mathematically-optimum

rendezvous trajectory that meets flight-specific constraints which are determined pre-mission. A first guess from which to converge need not be provided and rule bases are unnecessary. Prior to ARP, application of mathematical trajectory optimization techniques to flight design tools and approaches for vehicle-to-vehicle rendezvous has, for the most part, been neglected.

Key to the trajectory optimization for ARP is the McDonnell Douglas-developed Optimal Maneuver Analysis of Trajectories (OMAT) program. Under development since 1985, OMAT uses Primer Vector Theory in minimizing spacecraft Δv or fuel for n maneuvers, where n can be pre-defined, and either impulsive or finite burns can be selected. OMAT has been used for orbit transfer problems at LaRC, the Aerospace Corp., and for the National Aerospace Plane. Recent improvements have made OMAT a better tool for addressing real-world rendezvous applications. However, the code is still under development while a comprehensive set of 165 new rendezvous constraints is being mathematically defined and incorporated. These constraints will allow the user to optimize a spacecraft's trajectory within controlled points along its path. Currently, for example, a trajectory can be optimized within the constraints of not dropping below a defined minimum altitude while meeting a specified phase angle, at a certain time, relative to a target vehicle. The latest results show that a small savings in propellant can be obtained for near-circular, near-coplanar orbits, and a significant savings can be obtained for orbits that are non-circular and non-coplanar, when compared against current rendezvous planning tools.

ARP has the potential to significantly streamline both the preflight and real-time ground planning processes. The architecture of ARP is being designed to facilitate integration into a spacecraft's onboard software to expand the spacecraft's level of autonomy; thus, reducing its reliance on ground assistance solely to the uplink of navigation data.

ARP Architecture

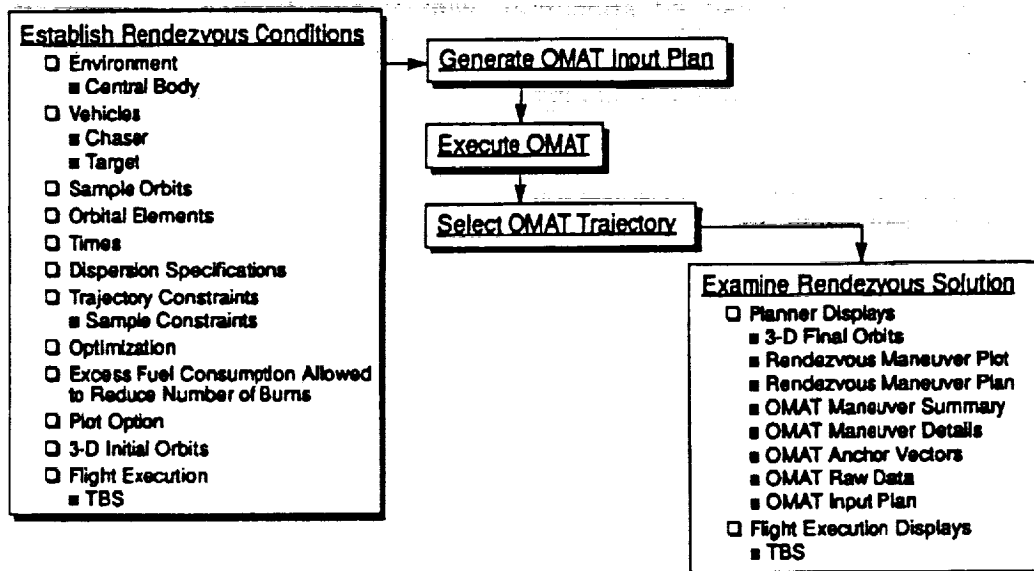

ARP incorporates chaser and target vehicle characteristics, state vector data, and pre-defined orbital constraints. It takes these inputs and generates a maneuver plan that is executed by other parts of the GN&C system. This process repeats itself after each rendezvous maneuver or navigation update until proximity operations begins.

The flexibility to quickly react to minor or even major real-time adjustments to complex schedules and vehicle states significantly enhances the probability of carrying out a successful mission. This need is a realistic one, given the large number of rendezvous missions expected of a generic resupply spacecraft. ARP's approach differs considerably from OMV targeting software, which consisted of pre-defined co-elliptic orbits with a limited ability to respond to orbital trajectory perturbations.

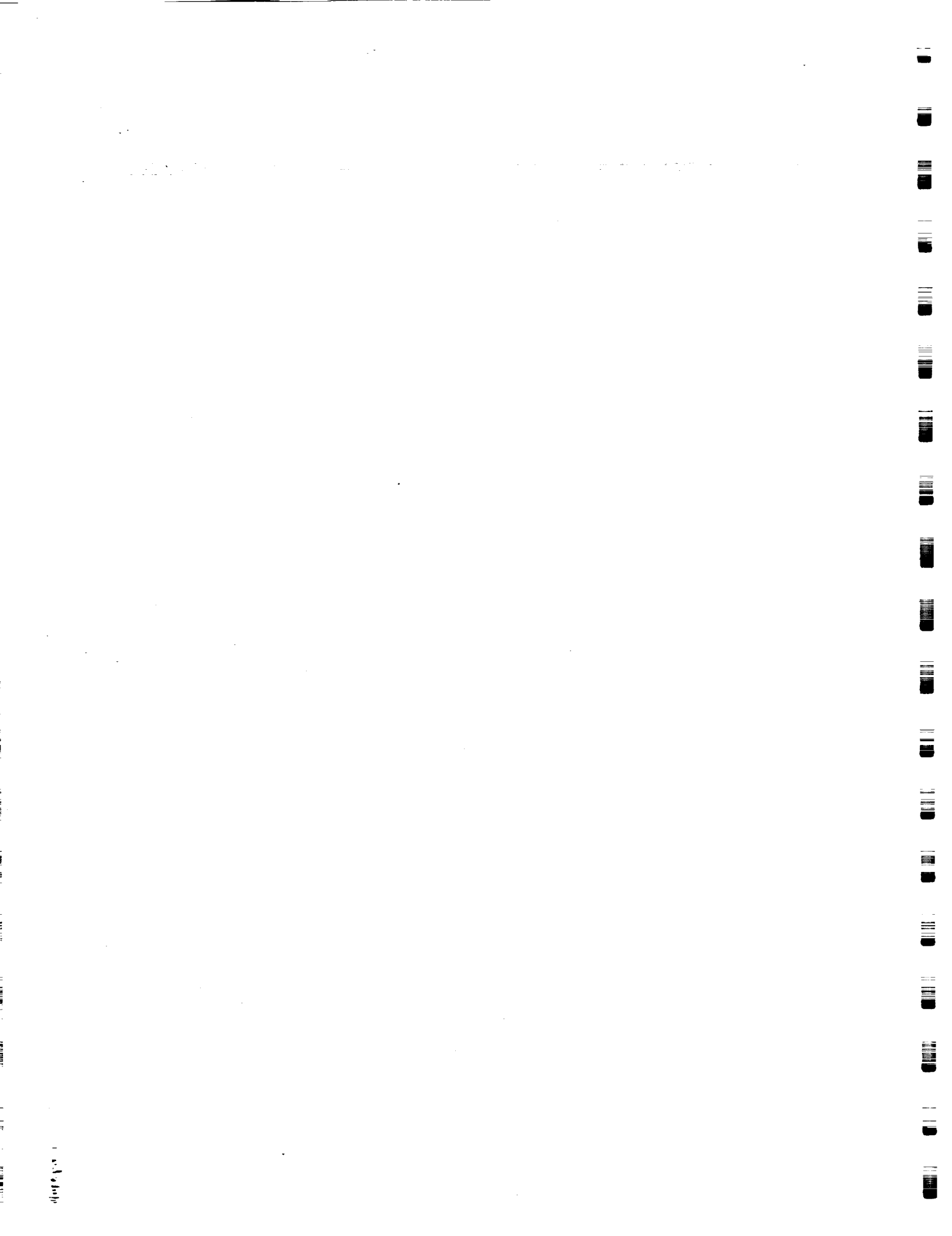

**U.S. Automated Rendezvous and Capture Capabilities
Review**

267-13
ABS. ONLY
146777
N 93 - 22293

Category 3 - Integrated Systems

Abstract Title: An Integrated Autonomous Rendezvous and Docking System Architecture Using Centaur Modern Avionics.

Author: Kurt Nelson

Affiliation: General Dynamics, Space Systems Division

Phone: 619 496-7386

Fax: 619 496-7676

Technical Details:

The avionics system for the Centaur upper stage is in the process of being modernized with the current state-of-the-art in strapdown inertial guidance equipment. This equipment includes an integrated flight control processor with a ring laser gyro based inertial guidance system. This inertial navigation unit (INU) uses two MIL-STD-1750A processors and communicates over the MIL-STD-1553B data bus. Commands are translated into load activation through a Remote Control Unit (RCU) which incorporates the use of solid state relays. Also, a programmable data acquisition system replaces separate multiplexer and signal conditioning units. This modern avionics suite is currently being enhanced through independent research and development programs to provide autonomous rendezvous and docking capability using advanced cruise missile image processing technology and integrated GPS navigational aids. A system concept has been developed to combine these technologies in order to achieve a fully autonomous rendezvous, docking and autoland capability. This paper will discuss the current system architecture and the evolution of this architecture using advanced modular avionics concepts being pursued for the National Launch System.

Historical Background:

The Centaur avionics suite has undergone a dramatic modernization over the last four years. Current state-of-the-art in strapdown inertial sensors and processor technology has been incorporated into the new Inertial Navigation Unit (INU). In addition to the Centaur avionics modernization program, substantial investment has been made in technologies focused at enhancing the capabilities of the Centaur avionics suite. These technologies include fault tolerance & redundancy management, and the integration of GPS and image processing sensors. The combination of these technologies integrated into an avionics suite can provide a very viable solution for an Autonomous Rendezvous & Docking system.

An advanced avionics architecture is also being developed by General Dynamics under the Multi-Path Redundant Avionics Suite (MPRAS) Advanced Development Program for the Advanced Launch System (ALS). This technology provides the architecture for the next generation launch vehicle systems. As this technology matures, the Centaur modern avionics architecture can be evolved to incorporate these advanced technologies.

Technology Maturity:

The technologies being utilized for the demonstrated autonomous rendezvous capability currently exist and are being flown on launch vehicles and military systems today. The advanced MPRAS architecture is in the development stage and is targeted to support the NLS vehicles. A technology evolution plan has been developed to transition from Centaur modern avionics to the advanced MPRAS architecture as it matures.

Test Experience:

The autonomous rendezvous and docking proof of concept has been demonstrated in a closed loop dynamic simulation using the image processing hardware, a representative flight control processor system, and a high fidelity vehicle model. A successful space station docking simulation has been developed and demonstrated.

The integration of the GPS position and velocity data into the inertial navigation unit is in progress and is scheduled for completion by the end of this year.

Sponsorship and funding:

Currently, the development of the integrated rendezvous and docking system is being pursued on IR&D funding. General Dynamics is working with Johnson Space Center, Marshall Space Flight Center, and Langley Research Center in a cooperative effort to combine the expertise and laboratory capabilities of each center to organize a multi-center test and demonstration program of this system.

N 93 - 22294

ABS ONLY
146778

P. 3

COLLISION AVOIDANCE FOR CTV REQUIREMENTS AND CAPABILITIES

Thomas P. Nosek



Engineering and Test Division
1 Space Park Bldg. R11/2384
Redondo Beach, CA 90278
(213)813-9028 Phone
(213)813-0415 FAX

Statement of technical details of the capability being described

CTV operations near Space Station Freedom will require positive collision avoidance maneuver (CAM) capability to preclude any chance of collision, even in the event of CTV failures. This paper discusses the requirements for CAM, and reviews the CAM design approach and design of the Orbiting Maneuvering Vehicle (OMV); this design met requirements for OMV operation near the Space Station, provided a redundant collision avoidance maneuver capability. Significant portions of the OMV CAM design should be applicable to CTV. The paper will summarize the key features of the OMV design and relate the CTV mission design to that of OMV's.

CAM is a defined sequence of events executed by the CTV to place the vehicle in a safe position relative to a target such as the Space Station. CAM can be performed through software commands to the propulsion system, or thorough commands pre-stored in hardware. Various techniques for triggering CAM are considered, and the risks associated with CAM enable and execution in phases are considered. OMV CAM design featured both hardware and software CAM capability, with analyses conducted to assess the ability to meet the collision-free requirement during all phases of the mission.

History of the origins and evolution of the capability

The OMV operated autonomously in the phase from Shuttle deployment through transfer orbit (although with ground command capability for certain operations) and then under pilot command after reaching a transfer point near the Space Station or target satellite for the purpose of final closure and docking. CAM protection was required in both phases of the mission with the system specification requiring "the capability to move safely away from a target payload or base of operations . . . ". OMV CAM design addressed the requirement that CAM operation could be initiated by the pilot on command, or automatically in the programmed mode of operation if critical failures occurred. Redundancy management onboard detected and responded to failures; the paper will describe this logic. To provide for fail-safe operation in both piloted and automatic modes, a dual mode CAM was designed: 'software' CAM, controlled by the onboard computers, and 'hardware' CAM, using updated parameters stored in hardware (registers) providing firing commands to the thrusters which would move the vehicle to a safe position.

Hardware CAM was designed to provide full fail-safe operation in the event of dual failures that made the vehicle impossible to control, notably in the computers. Onboard computers kept updated firing commands stored in the hardware CAM registers which would provide safe separation maneuvers in the event of complete failure in the onboard computing and control system. Superimposed on the dual mode CAM operation was an intermediate automatic backaway maneuver designed to operate in the event of communication link loss during rendezvous and docking operation. During terminal phase operation, the TV link providing the remote pilot with visual data is obviously critical, and the link loss mode, which would lead to automatic stationkeeping at a safe range, added an additional capability to provide safe operation while not requiring full CAM operation.

The level of maturity of the capability

Figures 1 and 2 illustrate the logic flow of the OMV CAM operation. Performance estimates were made of the CAM operation in various scenarios, including phases of automatic rendezvous operation (with the OMV under the control of the primary rendezvous sensor, a radar) and terminal rendezvous phases under pilot control (via the communications link through TDRS to the ground).

Test experience and/or experimental results

Software CAM, which is basically a form of the rendezvous guidance mechanization for OMV, can be initiated by the pilot and will transfer the vehicle to a point on the V bar at an operator selected distance. Performance verification of this CAM mode was accomplished by exercising the rendezvous guidance algorithms, using various V bar standoff distances, for selected closing scenarios (range and range rate). Hardware CAM evaluation was performed by computing the stored engine firing commands for various scenarios, and then simulating the response of the OMV to hardware CAM initiation. Trajectories of the vehicle were computed and confirmation of collision avoidance was confirmed. Hardware CAM registers were designed, built and tested, providing test firing commands in sequence to the attitude control thrusters.

Source/sponsorship and current funding estimates

TRW's OMV work was supported under contract to Marshall Space Flight Center. Current work on CTV applications and requirements is being supported under contract to MSFC as part of the NLS program and by IR&D funds in the area of servicing vehicles and autonomous spacecraft design.

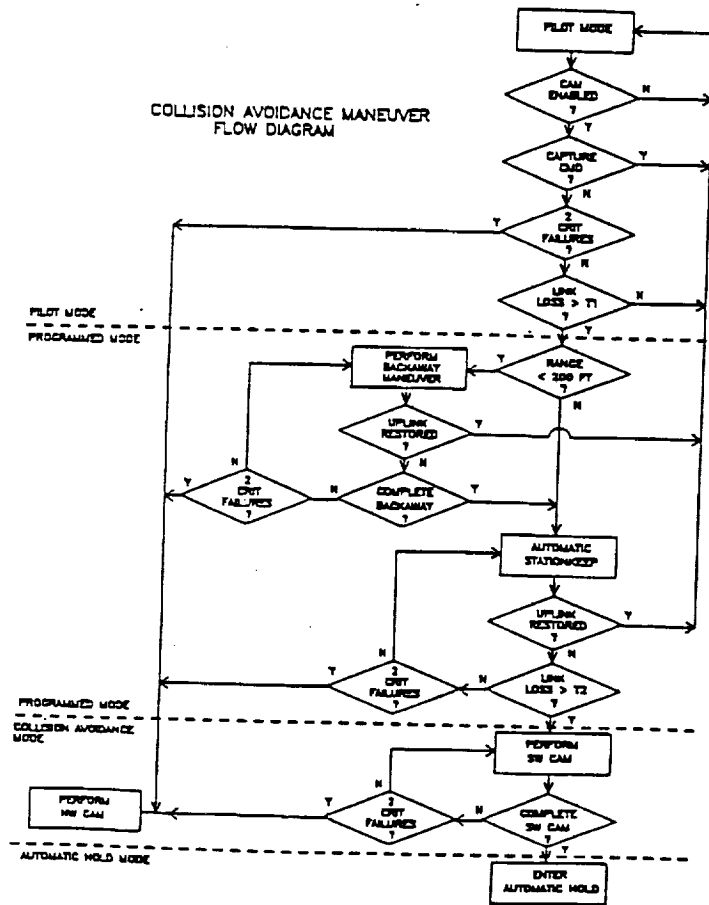

Figure 1

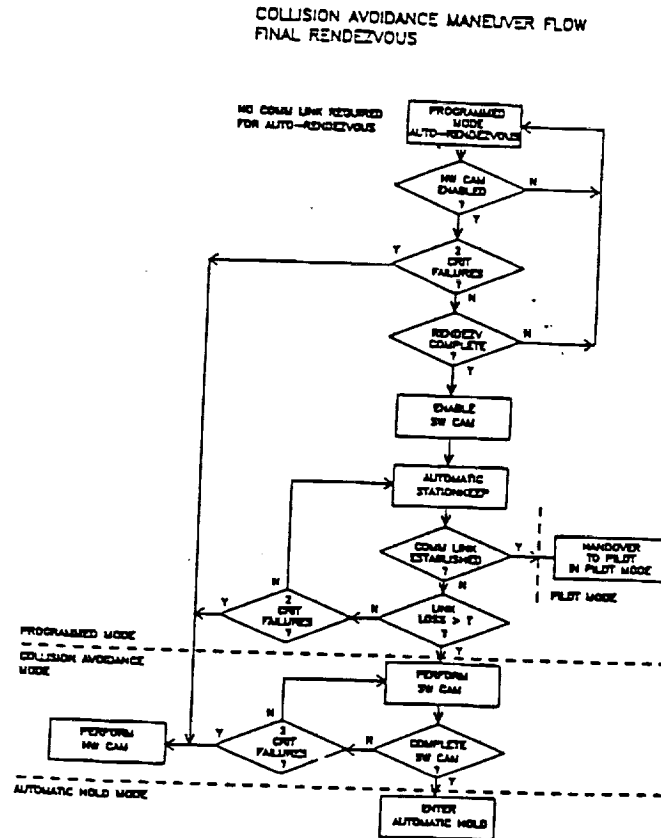
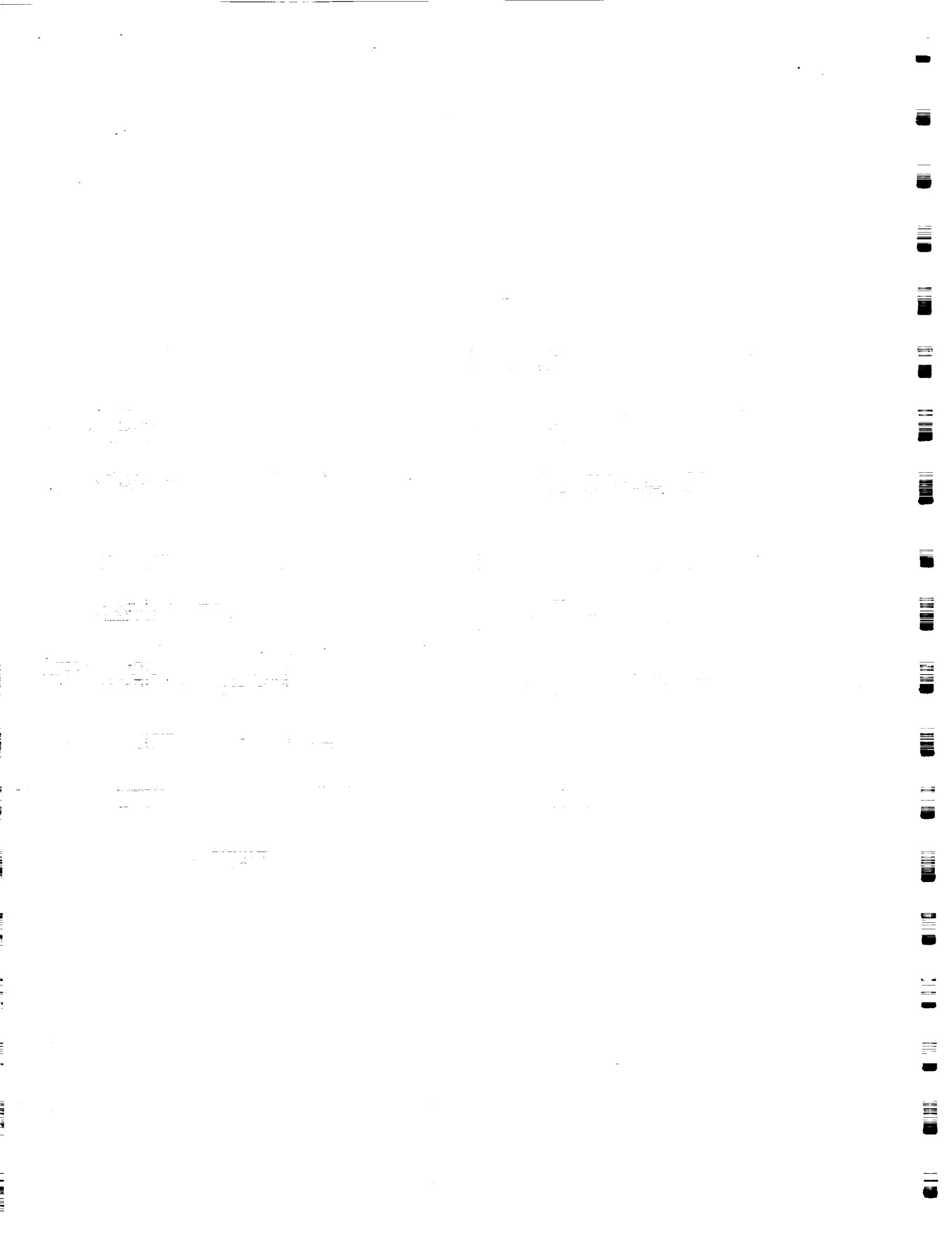

Figure 2



569-13

N 93-22295
146779

PILOTING DECISION AID FOR SPACECRAFT PROXIMITY OPERATIONS

Cole J. Pierce
McDonnell Douglas Space Systems Company
Houston, Texas 77062
MC: TB2EK / (713) 283-4087
FAX: (713) 283-4020

C-3

Abstract

BACKGROUND

The concept of a decision aid to assist the piloting of a powered vehicle during a near-field (< 2000 feet) rendezvous to another spacecraft is discussed.

Using Space Shuttle rendezvous with an orbiting satellite as an example, extensive practice is normally required to successfully effect such a rendezvous with a minimum of propellant. As a rule, variations on a "point and shoot" technique are optimized and used as much as possible.

A piloting decision aid (PDA) to assist in the pointing process has been conceived and is in the preliminary stages of development. This concept may be applied to Space Shuttle proximity operations for berthing with Space Station Freedom (SSF), for Shuttle rendezvous with other spacecraft, or for autonomous rendezvous of any unmanned vehicle with SSF.

The concept originated with a task order from NASA JSC for an automated piloting procedure and was influenced by an early air-to-air missile envelope display.

DESCRIPTION

[All references to the pilot may be applied to an autopilot, as well.]

Referring to Figure 1, the pilot is presented with a computerized view of the target, e.g., SSF. This view generally corresponds to what would be seen through the overhead window of the Space Shuttle during a Shuttle rendezvous.

Superimposed over this model is a *steering circle* which defines the cone into which the vehicle must fly in order to effect the rendezvous. The offset angle limits decrease with decreasing range, allowing more tolerance at greater distance and increasing precision at close ranges. The circle is centered on the berthing facility and collapses as the vehicle nears the target.

The steering circle is modeled by a tangent function which closely approximates published acceptable angle errors for a spacecraft approaching SSF. In the PDA program, however, a maximum radius of 200 feet is assigned. At approximately 711 feet range, the circle begins to collapse, reaching a minimum of 0.5 feet when the range is zero. See Figure 2.

State vector data may be displayed on the screen. The left side is used for this purpose in the example. Crosshairs may be used to display the v-bar of the chaser vehicle.

The key to the advantage of this concept is the utilization of a steering dot. As depicted in the figure, the steering dot indicates where, if there were no more propulsive burns, the vehicle would intersect the yz-plane at the target. The steering dot is augmented by a cruciform pattern of small circles which depict where the steering dot would be located if a burn were initiated in each direction. This is to enable the proper timing of y- and z- burns in the manual mode and to monitor correct responses in the automatic mode.

A speed bug is displayed at top of the display to assist the pilot in keeping the closure rate of the spacecraft within allowable limits. The closure rates are range-dependent, varying from (range/2000) feet per second down to 0.275 fps (maximums) and from (range/2000 - 0.35) fps down to 0.02 fps (minimums).

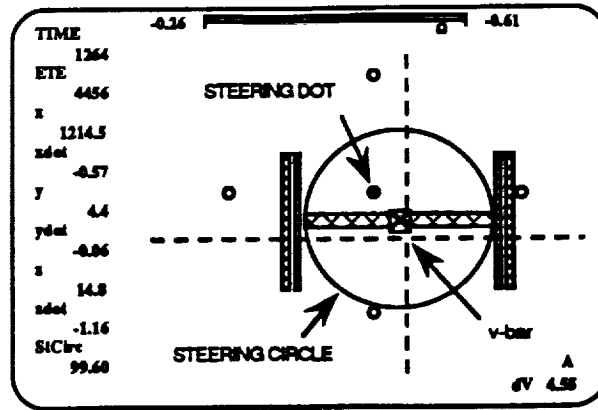

Figure 1.

The process then becomes one of simply flying the dot into the circle. Rather than experimentation and educated guessing, the pilot needs only to command burns to fly the dot into the circle and, as the circle shrinks, keep it there.

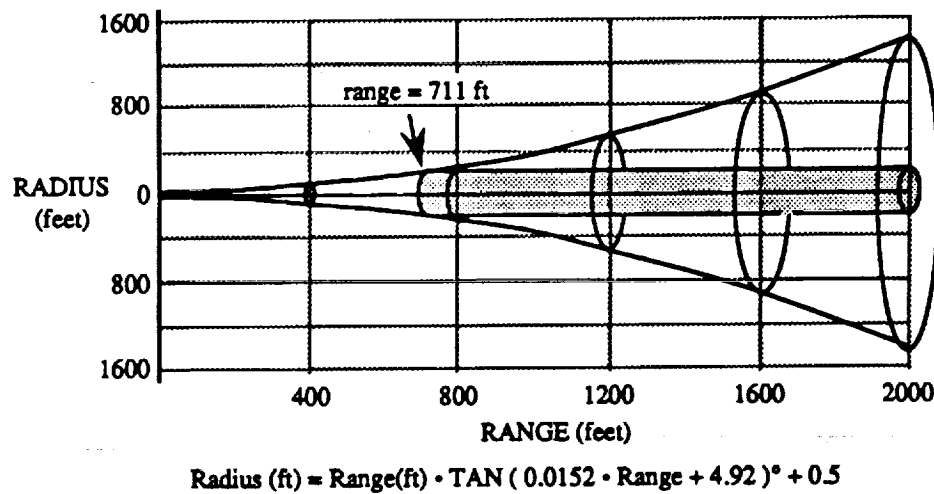

Figure 2.

The program is modularized into the following segments: (1) introduction; constants and variables defined; (2) orbital parameters defined or computed; (3) local atmospheric density and differential drag computed; (4) initial state vector defined; (5) output display generated; (6) trajectory propagated; (7) corrections computed; (8) state vector updated; and (9) output display updated.

Clohesy-Wiltshire equations of relative motion are used. The C-W equations are linearized formulations of orbital mechanics and generally accurate to better than 1 part in 100,000 at ranges of several miles. Their accuracy and speed lend

themselves reliably and efficiently to application in this simulation. A relative drag factor is included.

Propulsive impulses are currently 0.10 fps in the y and z directions and 0.25 in the x. These generally conform to current simulation assumptions, although the final installation of the program will utilize the mass properties and thruster positioning and vectoring of real and simulated vehicles for a true 6-DOF simulation.

In order to propagate the position of the yz-intercept, some means of estimating the time to intercept is necessary. From the allowable maximum and minimum range rates, an average is determined which is integrated over the existing range. The resulting equation of time as a function of range closely approximates the actual times required as recorded on a series of simulations.

RESULTS

Preliminary results are promising:

Initial range	2000 ft
Initial y-offset (out-of-plane)	10 ft
Initial z-offset	20 ft
Initial x-velocity	-1.5 fps
Initial y-, z- velocities	0.0 fps
Position (y, z) tolerance at termination	± 0.5 ft

Total ΔV required for rendezvous:

10.55 fps for +vbar approach
13.75 fps for -vbar approach

For a Shuttle-type vehicle, this equates to a propellant burn of less than 100 pounds. Due to the visual cues provided, manual operation should be able to attain this efficiency with minimal practice.

CONTINUING DEVELOPMENT

In order to implement the PDA in actual systems, a precise range/range rate sensor capable of 0.1 fps resolution and a relative position sensor accurate to 0.1 foot or 0.05% are required. More accurate sensors obviously would improve the performance of the system. In addition, integration of the algorithms with existing sensor and graphics software and hardware would be necessary. Initial positioning errors and sensor inaccuracies are easily handled, as y and z errors of 200 feet at a range of 700 feet are within allowable tolerances. Errors in excess of these figures will normally only require a single initial burn to effect a nominal near-field rendezvous. An abort algorithm has been considered and would be relatively simple to implement.

The program is currently PC-based, with capability to support both CGA and VGA graphics, but is being rewritten in C as it becomes fully developed and verified. Although currently limited to point masses and unit vector propulsion, the program is being expanded and will be included in the NASA/JSC Orbital Operations Simulator (OOS) man-in-the-loop, real-time, 6-DOF simulation. Meanwhile, the PC-based versions will serve as stand-alone proof-of-concept programs as well as providing a demonstration capability at the desktop.

This work is being funded by the Systems Engineering Branch of the Engineering Directorate, NASA/JSC.

Dear Sir,

I am writing to you regarding the matter of the contract between us.

I have reviewed the terms and conditions of the contract and find them acceptable.

Yours faithfully,

[Signature]

[Name]

[Title]

[Address]

[Address]

[Address]

[Address]

[Address]

[Address]

[Address]

[Address]

[Address]

[Address]

[Address]

[Address]

[Address]

[Address]

[Address]

[Address]

[Address]

[Address]

[Address]

[Address]

[Address]

[Address]

[Address]

[Address]

[Address]

[Address]

[Address]

[Address]

[Address]

[Address]

570-18
 N 93422296
 146780

Spacecraft Rendezvous Operational Considerations Affecting Vehicle Systems Design and Configuration

Ellen E. Prust
 McDonnell Douglas Space Systems Company - Houston, Texas
 (713) 283-4277 / MC: MDCB2AI / Fax: (713) 283-4020

P. 3

Introduction

One lesson learned from OMV program experience is that Design Reference Missions must include an appropriate balance of operations and performance inputs to effectively drive vehicle systems design and configuration. Rendezvous trajectory design is based on vehicle characteristics (e.g., mass, propellant tank size, mission duration capability) and operational requirements, which have evolved through the Gemini, Apollo, and STS programs. This presentation summarizes operational constraints affecting the rendezvous final approach.

The two major objectives of operational rendezvous design are vehicle/crew safety and mission success. Operational requirements on the final approach which support these objectives include:

- tracking/targeting/communications
- trajectory dispersion and navigation uncertainty handling
- contingency protection
- favorable sunlight conditions
- acceptable relative state for proximity operations handover
- compliance with target vehicle constraints

A discussion of the ways each of these requirements may constrain the rendezvous trajectory follows. Although the constraints discussed apply to all rendezvous, the trajectory presented in "Cargo Transfer Vehicle Preliminary Reference Definition" (MSFC, May 1991) was used as the basis for the comments below.

Discussion

Figure 1 is a target-centered relative motion plot of the ground-up rendezvous trajectory. Operational constraints to be considered in design of the final approach are illustrated on the figure.

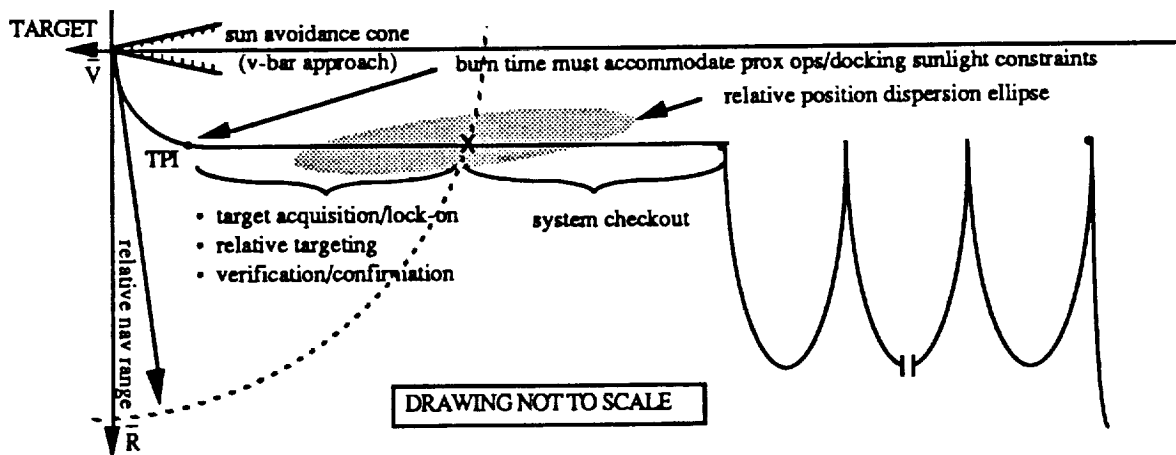

FIGURE 1. Rendezvous Operational Constraints

Tracking / Targeting / Communications

Adequate time for tracking, targeting, and necessary communications must be allotted prior to terminal phase initiation (TPI) and midcourse burns. As shown on Figure 1, the TPI burn may not take place until the chaser has been within relative navigation range for sufficient time to acquire and lock-on to the target vehicle, and for TPI burn targeting to be completed and verified. For example, the terminal phase trajectory shown in the CTV Preliminary Reference Document (300° transfer initiated from 20 nmi below the SSF) requires a radar range of ~100 nmi, assuming 15 minutes for target acquisition, lock-on, and confirmation. Alternatives to reduce the radar range requirement include inserting higher to reduce the target/chaser Δh at TPI, or initiation of TPI at a "stable orbit point" on the target v-bar.

Additionally, the final approach (pre-TPI through TPF) trajectory must provide favorable conditions for accurate target tracking. This includes advantageous relative motion, target background, and sunlight conditions, if required.

Tracking, targeting, and communications requirements all extend the rendezvous timeline. Target tracking needs also influence navigation sensor selection and insertion altitude specification (which affects onorbit fuel requirements).

Trajectory Dispersion and Navigation Uncertainty Handling

The final approach design must provide a satisfactory trajectory for the expected range of dispersions (an example relative position dispersion ellipse is illustrated on Figure 1). To preclude premature contact between the chaser and target vehicles, the chaser/target relative position must remain safely outside the envelope of predicted dispersions during the entire final approach. Additionally, the chaser-to-target range must remain greater than the navigation range uncertainty.

The relative trajectory is controlled by maneuver placement and target offset points. The TPI offset point should be chosen so that an acceptable trajectory can be flown for any point within the predicted dispersion ellipse. For the STS, the TPI downrange offset was chosen large enough to prevent collision with the target vehicle prior to TPI, and the radial offset was defined to ensure a positive separation rate from the target under 3σ dispersed conditions. After TPI, dispersions can be reduced by targeting midcourse burns, which correct TPI burn errors and adjust the trajectory based on current navigation data.

Dispersion and navigation uncertainty handling may influence insertion altitude and the onorbit trajectory, impacting both propellant and mission timeline requirements.

Contingency Protection

Since it is impossible to plan for every contingency, each spacecraft program must define planned contingencies and the time allotted to resolve them. Planned contingencies may include late or missed burns, navigation and communication failures, timeline delays, and other system failures.

Passive collision avoidance protects against inadvertent contact between the chaser and target in a chaser system failure scenario. Using passive collision avoidance, the trajectory is designed so the chaser trajectory won't intercept the target unless the terminal phase sequence is initiated. Coelliptic and stable orbit trajectories which use passive collision avoidance are shown in Figure 2 below. In each case, the dotted line shows the trajectory followed if the TPI burn is not executed.

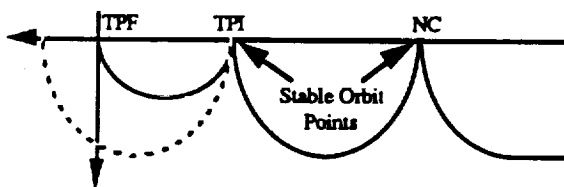

FIGURE 2a. Stable Orbit Approach

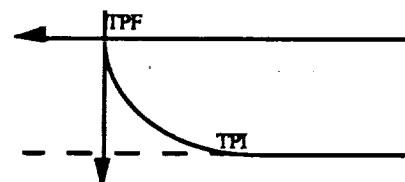

FIGURE 2b. Coelliptic Approach

The ability to halt and then restart the rendezvous increases the probability of mission success in the case of any contingency which prevents completion of the rendezvous at the nominal time (e.g., relative navigation, communication, or docking system failure). Although a contingency plan can be developed for any approach trajectory, the stable orbit approach has the advantage of one or more stopping points built into the nominal profile. After resolution of a contingency, the chaser may resume its *nominal* terminal phase trajectory with minimal fuel impact. Operational simplicity is a high priority for rendezvous, especially for automated or autonomous operations.

After TPI, the chaser and/or target must be capable of performing collision avoidance maneuvers in case of a contingency which prevents completion of the rendezvous. Again, it is desirable to maintain the ability to complete the rendezvous at a later time while minimizing fuel and time requirements, and operational complexity.

Contingency protection allowances primarily impact mission duration and fuel requirements.

Favorable Sunlight Conditions

Although sun lighting of the target during proximity operations and docking may be desirable, direct or reflected sunlight may interfere with optical sensors. An example sun avoidance cone is depicted on Figure 1. The final approach trajectory must set up correct lighting conditions for proximity operations and docking. A strategy used by the STS to achieve desirable lighting conditions is inclusion of a coelliptic phase before the final sequence of rendezvous maneuvers. This sequence is then initiated at a time such that future lighting requirements are satisfied. Sunlight concerns may affect selection of navigation sensors as well as the mission timeline.

Proximity Operations Handover

The terminal phase must provide a relative state (position and velocity) at transition from near field to proximity operations which complements proximity operations piloting capabilities. The relative state at proximity operations handover is a function of terminal phase target offset points and transfer angles. Terminal phase trajectory design influences both timeline and propellant requirements.

Target Vehicle Constraints

The final approach trajectory must comply with all target constraints, such as target orientation. For rendezvous with the SSF, command and control zone rules must be observed, as well as other station operations requirements. Target constraints may result in insertion altitude, propellant or timeline constraints, and may also influence selection of navigation sensors.

Summary

Vehicle/crew safety and mission success goals dictate many operational requirements not directly related to vehicle performance. The resulting constraints place strict limitations on the rendezvous final approach trajectory, which must be accommodated by vehicle hardware and software design. All operational requirements discussed above affect the rendezvous timeline to some extent, which dictates vehicle battery lifetime. Tracking requirements, dispersion handling, and SSF command and control zone requirements may directly influence chaser insertion altitude, and therefore onorbit propellant requirements. Trajectory modifications to accommodate contingency protection and dispersion handling capabilities may impose additional propellant requirements. Sunlight and tracking considerations, as well as target vehicle constraints, should be factors in selection of navigation sensors. It is hoped that the above discussion will enhance understanding of rendezvous issues affecting vehicle design, and that these issues will be considered in the early design stages of future rendezvous vehicles.

[The page contains extremely faint and illegible text, likely bleed-through from the reverse side of the document. The text is too light to be accurately transcribed.]



ABSTRACT

571-36
ABS. ONLY
N 93/422297

Title: Approach Range and Velocity Determination Using Laser Sensors and Retroreflector Targets.

Author: L. Race, K. J. Kim, J. Wang, W. Schoknecht, and W. J. Donovan, Rockwell International, Telephone (714)762-2472, FAX (714)762-0766

Technical Details: Laser Sensors can be used to provide range and velocity determination for the Cargo Transfer Vehicle (CTV) while in proximity to Space Station Freedom (SSF). These new design sensors combine a random-modulation continuous wave diode laser with a binary optical scanner to provide a low-power, eye-safe alternative to conventional laser systems.

History: These results are based on continuing studies to define automated tracking, rendezvous, station keeping, and berthing/capture systems. The studies were initiated, by Rockwell electro-optical specialists, in response to the space shuttle requirement for automatic docking systems.

Current Status: A demonstration unit design is underway. Ongoing simulation and modeling are further defining system operational parameters. Specific range, accuracy, and reliability issues are under consideration relating to the CTV application.

Funding: The investigation is funded by Rockwell at \$200,000 per year.

Rockwell International is conducting an ongoing program to develop Laser Docking Sensors (LDS) that provide high performance and high intrinsic value while meeting all mission objectives. These LDS systems are now being required to aid future spacecraft docking, station keeping, and berthing/capture systems. Improved automated tracking, rendezvous, soft docking, and capture will be required in the construction and support of SSF and future orbiting platforms. The development of a practical LDS requires an easy-to-operate, low-cost, compact system. The current LDS program draws on a number of internally funded programs. Support from internal research and development (IR&D) funding is currently budgeted at \$200,000 in FY'92.

A wide range of options for laser range detection equipment, ranging from commercial technology to specialized military systems, has been evaluated. This evaluation focused on both direct applicability of existing systems and usability of specific technologies contained in these systems. From these efforts it was determined that a new approach provided the greatest promise of fulfilling all mission requirements at the lowest life-cycle cost.

This new LDS approach combines a random-modulation continuous wave diode laser with a binary optical scanner. It requires only a low input power level and provides eye-safe operation. The target is a conventional design retroreflector. The current design incorporates smart, autonomous on-board processing using techniques of pattern recognition and automatic ranging and alignment to provide high performance in a compact, low-cost system. Use of retroreflectors minimizes the equipment that must be placed on SSF.

Current performance analysis indicates range errors and velocity errors will both be less than one percent. Maximum range will be in excess of 500 feet with longer ranges possible if required in the CTV design. All components are based on existing technology and are space qualifiable. Operation does not produce, and is not affected by radio frequency interference.

In the CTV application, attitude information can be obtained by triangulation to multiple targets. In a normal operating mode, each of three LDS systems would track its own target. This configuration provides maximum update rates while allowing each system to remain in lock on its target. To support graceful degradation it is possible to track multiple targets with the same LDS if the lower update rate and time to reacquire each target between measurements are allowed by a lesser closing velocity between the CTV and SSF.

Open study issues remain on definition of exact ranges required for the CTV mission. Consideration of long-term space effects on the optical surfaces retroreflectors is also required with consideration of alternative material technologies most likely to resolve this issue.

Automated Rendezvous and Docking with Video Imagery

572-13
ABS ONLY
146782
P-1

**Mike Rodgers
Larry Z. Kennedy
Applied Research, Inc.
Huntsville, Alabama**

N 93 - 22298

For rendezvous and docking, assessing and tracking relative orientation is necessary within a minimum approach distance. Special target light patterns have previously been considered for use with video sensors for ease of determining relative orientation. This work is a generalization of those approaches. At certain ranges, the entire structure of the target vehicle constitutes an acceptable target; at closer ranges, substructures will suffice. Acting on the same principle as the human intelligence, these structures can be compared with a memory model to assess the relative orientation and range. Models for comparison are constructed from a CAD facet model and current imagery. This approach requires fast image handling, projection, and comparison techniques which rely on rapidly developing parallel processing technology.

Relative orientation and range assessment consists of successful comparison of the perceived target aspect with a known aspect. Generating a known projection from a model within required times, say subsecond times, is only now approaching feasibility. With this capability, rates of comparison used by the human brain can be approached and arbitrary known structures can be compared in reasonable times.

Future space programs will have access to powerful computation devices which far exceed even this capability. For example, the possibility will exist to assess unknown structures and then control rendezvous and docking, all at very fast rates. We now take the first step which has the current utility, namely applying this to known structures.

1950

1950

1950

1950

1950

1950

1950

1950

1950

1950

1950



6DOF SIMULATION SYSTEM FOR EVALUATING AUTOMATED RENDEZVOUS AND DOCKING SPACECRAFT

146783

Kenneth H. Rourke
Roy K. Tsugawa

P. 3



Federal Systems Division
1 Space Park Bldg. R11/2337
Redondo Beach, CA 90278
(213)812-2628 Phone
(213)812-8016 FAX

Statement of technical details of the capability being described

Future logistics supply and servicing vehicles such as CTV must have full 6 degree of freedom (6DOF) capability in order to perform requisite rendezvous, proximity operations and capture operations.

The design and performance issues encountered when developing a 6DOF maneuvering spacecraft are very complex with subtle interactions which are not immediately obvious or easily anticipated. In order to deal with these complexities and develop robust maneuvering spacecraft designs, a simulation system and associated family of tools are used at TRW for generating and validating spacecraft performance requirements and guidance algorithms. This presentation provides an overview of the simulator and tools. These are used by TRW for autonomous rendezvous and docking research projects including CTV studies.

The TRW high fidelity 6DOF spacecraft dynamics simulator is called the orbital maneuvering and servicing simulator (OMSS). This simulator is supported by various analysis tools which are used for top level mission and configuration design and initial condition generation. These tools include an interactive targeting trajectory design tool, thruster configuration and evaluation tools, and control loop response and gain selection tools.

The OMSS includes models for all of the key guidance, navigation, control, and propulsion systems for the maneuvering vehicle. Full 6DOF orbital dynamics are simulated for multiple independent vehicles (chaser and multiple targets). The environmental models include J2 gravity, provision for atmosphere and drag models, sun position, and TDRS locations. The OMSS is a high fidelity 6DOF simulator with sufficient accuracy and functionality to have been suitable for deriving orbital maneuvering vehicle (OMV) system and man-in-the-loop technical requirements. All of the autodocking, autonomous proximity operations, and automated rendezvous algorithms developed by TRW Federal Systems Division have been implemented and tested on the OMSS. The OMSS includes a Kalman filter for processing the simulated sensor inputs from the rendezvous sensor, radar, or GPS. An automated mission sequencer has been installed for simulating automated rendezvous with possible midcourse corrections, and the

transition to proximity operations. The OMSS has also been interfaced to an actual docking sensor and is used to drive the full-scale motion based simulator at MSFC. The OMSS retains the capability for man in the loop operations.

The primary mission planning support tool which is used to generate initial condition data for the OMSS is the targeting tool called Target. Target is an interactive, graphics based tool which runs on an IBM PC and quickly generates and displays orbital trajectories for rendezvous and phasing. Target includes J2 gravity perturbations and takes J2 biasing into account when performing Lambert transfers. Target allows a user to very quickly see the effects of transfer angles, elevation angles, and downrange displacements on the trajectory shape and delta-V required. Target may be used as a simple initial condition calculator to convert between orbital elements, rectangular ECI, and target relative LVLH coordinates; as a propagation tool for forwards and backwards state vector propagation; and as a mission segment planning tool. By stringing mission segments together, Target allows complicated mission profiles to be developed.

Vehicle thruster configurations are evaluated using two tools - a thruster response spreadsheet, Thrust, and a jet select table evaluation program, Jet_pick. The spreadsheet, Thrust, is especially useful for providing acceleration data when maneuvering heavy payloads with a large center of gravity (CG) displacement from the thruster planes. Thrust allows the rapid selection of thruster sizes and lever arms necessary in order to achieve acceptable control authority. Jet_pick is used to grade the acceleration response from a thruster configuration and jet select table. Any errors within the 728 elements of a jet select table are flagged. This is an important tool since an error in a single maneuver combination might be too small to be detected just by monitoring the simulation results from the OMSS. Jet_pick also allows a quick method for evaluating the effects of thruster output or mounting errors and CG displacements on the resulting vehicle accelerations. Jet_pick uses the same data format as the OMSS for ease of data transfer.

A final set of support tools are the control loop gain selection and evaluation tools. These tools are a spreadsheet, Control1, which allows the user to select the proper gains for either the translational or rotational control loops, and a 2 axis control loop response simulation program, Control2. Control1 allows the user to specify desired deadbands and maneuver rates and computes the control loop gains which correspond to these desired limits. In addition, an indication of control loop stability and limit cycle period is provided based on the estimated control accelerations. The 2 axis control loop simulation, Control2, simulates the cross coupling or a translational axis and a rotational axis (+Z and +Pitch for example). The control loop duty cycle times, effective translational accelerations, stability, and damping are easily observable by examining the output or plotting the data. The response data is presented in two formats, a strip chart which shows position and attitude versus time, and Lotus compatible numeric position, velocity and control loop activity data.

History of the origins and evolution of the capability

These simulations and tools provide a powerful foundation for deriving and validating performance requirements, designing and prototyping algorithms, and evaluating spacecraft performance characteristics. The legacy for these tools dates to the Phase B contract for the OMV and related TRW IRAD projects. Throughout the OMV program the simulation was refined and validated. The OMSS formed the basis for the OMV prototype ground control console which was used to develop flight procedures and human/machine interfaces. The other tools were developed more recently for TRW IRAD projects and the CTV study.

The level of maturity of the capability

All of the tools and simulations mentioned above are mature and fully developed. They continue to evolve with enhancements and added capabilities being incorporated as needed.

Test experience and/or experimental results

TRW has extensive simulations experience. The tools and simulations described here are in current use and are providing data for automated rendezvous and docking requirements development and for CTV configuration and mission evaluation. Figures 1 and 2 show actual OMSS output data for a representative data run. The figures show the approach profile for a heavily loaded CTV with no forward propulsion module. This simulation run begins at the end of a stable orbit rendezvous from 1 nmi to 1000 ft behind the space station. This rendezvous results in a 2 ft/s radial approach velocity to V-bar which the CTV must null out while maintaining LVLH attitude hold.

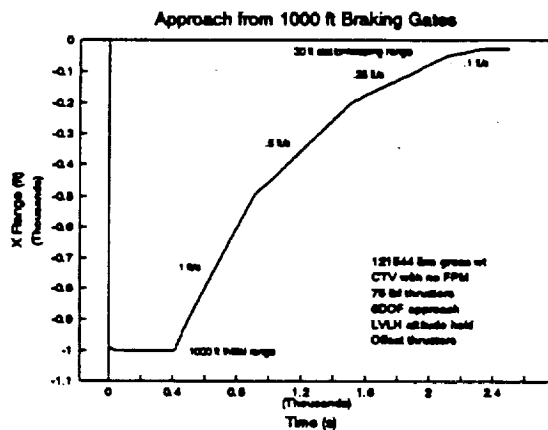

Figure 1.

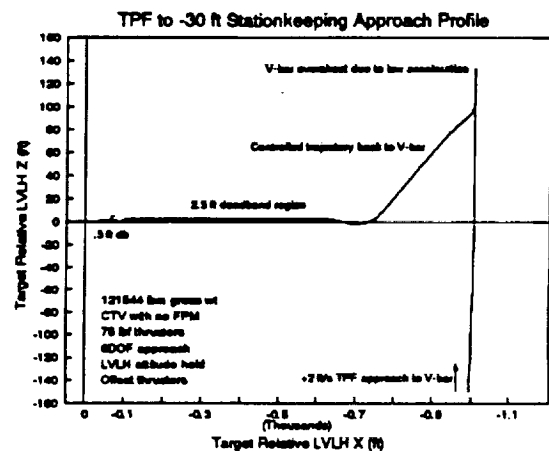

Figure 2.

Source/sponsorship and current funding estimates

The tools described were developed on TRW IRAD funds. During the OMV program, additional capabilities were added to enhance the simulation system. The simulation system is currently being used to support TRW IRAD and the CTV study.

1. The first part of the document discusses the importance of maintaining accurate records of all transactions.

2. It is essential to ensure that all data is entered correctly and that the system is regularly updated.

3. The second part of the document outlines the various methods used to collect and analyze data.

4. These methods include surveys, interviews, and focus groups, each with its own strengths and weaknesses.

5. The third part of the document describes the different types of data that can be collected and how they are used.

6. This includes primary data, which is collected directly from the source, and secondary data, which is collected from existing sources.

7. The fourth part of the document discusses the various techniques used to analyze data and the importance of choosing the right technique.

8. These techniques include statistical analysis, content analysis, and grounded theory, among others.

9. The fifth part of the document describes the different types of data visualization and how they are used to present data.

10. This includes bar charts, line graphs, pie charts, and scatter plots, each with its own advantages and disadvantages.

11. The sixth part of the document discusses the various methods used to collect and analyze data.

12. These methods include surveys, interviews, and focus groups, each with its own strengths and weaknesses.

13. The seventh part of the document describes the different types of data that can be collected and how they are used.

14. This includes primary data, which is collected directly from the source, and secondary data, which is collected from existing sources.

15. The eighth part of the document discusses the various techniques used to analyze data and the importance of choosing the right technique.

16. These techniques include statistical analysis, content analysis, and grounded theory, among others.

17. The ninth part of the document describes the different types of data visualization and how they are used to present data.

18. This includes bar charts, line graphs, pie charts, and scatter plots, each with its own advantages and disadvantages.

Proposed CTV Design Reference Missions in Support of
Space Station Freedom
(Abstract)

574-1B
ABS ONLY
146784
N93-22800

R.J. Saucillo
MDSSC Engineering Services Division
(301)670-7925

W.M. Cirillo
NASA LaRC SSFO Advanced Programs Office
(804)864-1938

Use of design reference missions (DRMs) for the CTV in support of Space Station Freedom (SSF) can provide a common baseline for the design and assessment of CTV systems and mission operations. These DRMs may also provide baseline operations scenarios for integrated CTV, Shuttle, and SSF operations. This presentation describes proposed DRMs for CTV, SSF, and Shuttle operations envisioned during the early post-PMC time frame and continuing through mature, SSF evolutionary operations. These proposed DRMs are outlines for detailed mission definition; by treating these DRMs as top-level input for mission design studies, a range of parametric studies for systems / operations may be performed.

CTV-SSF design reference missions for the early post-PMC time frame relate to NLS delivery of SSF resupply logistics. In this scenario, an NLS-based CTV delivers SSF logistics via autonomous rendezvous and is temporarily berthed at SSF until return to Earth by the Shuttle. A second potential mission is the atmospheric disposal of SSF waste by the CTV. Prior to return to Earth by the Shuttle, the CTV delivers SSF waste to an orbit providing near term atmospheric entry; the CTV then returns to SSF. Potential CTV-SSF design reference missions for the SSF evolution time frame include:

- Delivery of SSF growth elements
- In-situ or SSF-based free flyer servicing
- SEI support including transport of crew/cargo to an assembly node.

Shuttle flight design experience, particularly rendezvous flight design, provides an excellent basis for DRM operations studies. To begin analysis of the DRMs, Shuttle trajectory design tools have been used in "single case" analysis to define CTV performance requirements. A summary of these results is presented herein.

100



100

575-17
ABS ONLY

Office of Space Flight
Standard Spaceborne Global Positioning System User Equipment Project

Penny E. Saunders
Tracking and Communications Division
Engineering Directorate
Johnson Space Center
National Aeronautics and Space Administration
(713)483-1485
FAX (713)483-5830

N 98-22301
P-1

The Global Positioning System (GPS) provides users autonomous, real-time navigation capability. A vehicle equipped with GPS user equipment can receive and process signals transmitted by a constellation of GPS satellites and derive from the resulting measurements the vehicle's position and velocity. Specified accuracies range from 16 to 76 meters and 0.1 to 1.0 meters/second for position and velocity, respectively. In a rendezvous and docking scenario, the use of a technique called relative GPS can provide range and range rate accuracies on the order of 1 meter and 0.01 meters/second, respectively. Relative GPS requires both vehicles to be equipped with GPS user equipment and a data communication link for transmission of GPS data and GPS satellite selection coordination information. Through coordinated satellite selection, GPS measurement errors common to both users are cancelled and improved relative position and velocity accuracies are achieved.

NASA has spent many years pursuing the incorporation of GPS into its space vehicles. The Space Shuttle is scarred for two strings of GPS user equipment. The Space Station has baselined GPS to provide Space Station position and velocity, time reference data, and relative tracking of cooperative, unmanned vehicles within the Station's command and control zone. Consideration is being given to the use of GPS in the Assured Crew Return Vehicle and in the various launch and orbital transfer vehicles. Johnson Space Center (JSC) has worked with NASA Headquarters and several field centers to develop the concept of a standard GPS user equipment set designed to be used in multiple space vehicle programs. The decision was made by the Associate Administrator for the Office of Space Flight (Code M) to pursue a standard GPS development for use in Code M space vehicles.

The standard GPS design approach is to use off-the-shelf GPS user equipment and modify the design to provide a modular architecture, the required NASA vehicle interfaces, and the capability for growth to include future user requirements. Over half a dozen GPS user equipment manufacturers responded to a request for information regarding the approach manufacturers would take in the development of standard spaceborne GPS user equipment. All vendors responded with proposals to modify an existing design.

The standard GPS project definition phase is planned for FY92-93 with the development phase beginning in FY94 and the production phase beginning in FY96. The project is managed by the Advanced Development Office (Code MD) with JSC designated as the lead center for managing the technical aspects of the project. The project is funded for FY92-93. Funding for the development and production phase is uncertain. Definition phase activities include the preparation of a request for proposal with the associated procurement specification, the performance of required trade studies, and the testing of candidate GPS user equipment sets.

This presentation describes the background, the design approach, the expected performance and capabilities, the development plan, and the project status. In addition, a description of relative GPS, the possible GPS hardware and software configurations, and its application to automated rendezvous and capture is presented.

1. The first part of the document discusses the importance of maintaining accurate records of all transactions.

2. It is essential to ensure that all data is entered correctly and consistently across all systems.

3. Regular audits should be conducted to verify the accuracy and integrity of the information.

4. The second section outlines the various methods used to collect and analyze data.

5. These methods include surveys, interviews, and the use of specialized software tools.

6. Each method has its own strengths and weaknesses, and they are often used in combination.

7. The third part of the document provides a detailed overview of the data analysis process.

8. This process involves identifying patterns, trends, and anomalies within the collected data.

9. Statistical techniques are often employed to draw meaningful conclusions from the data.

10. The final section discusses the importance of communicating the results of the analysis.

11. Clear and concise reporting is crucial for ensuring that the findings are understood and acted upon.

12. This section also touches upon the ethical considerations surrounding data collection and analysis.

13. It is important to be transparent about the methods used and to protect the privacy of the data subjects.

14. In conclusion, this document provides a comprehensive guide to effective data management and analysis.

15. By following the principles and practices outlined here, organizations can maximize the value of their data.

U.S. Automated Rendezvous and Capture Capabilities Review
Category 5- Supporting Infrastructure

5976-13
ABS ONLY
146786
N93-22302

Abstract Title: The development of an Autonomous Rendezvous and Docking Simulation using Rapid Integration and Prototyping Technology

Author: John H. Shackelford, John D. Saugen, Michael J. Wurst and James Adler.

Affiliation: General Dynamics, Space Systems Division
P.O. Box 85990, San Diego, Ca. 92186-5990
Phone: (619) 496-7240
Fax: (619) 496-7676

Technical Details:

A generic planar 3 degree of freedom simulation has been developed that supports hardware in the loop simulations, guidance and control analysis, and can directly generate flight software. This simulation was developed in a small amount of time utilizing rapid prototyping techniques. This paper describes the approach taken to develop this simulation tool, the benefits seen using this approach to development and will also describe on-going efforts to improve and extend this capability.

The simulation is composed of 3 major elements: (1) Docker dynamics model, (2) Dockee dynamics model, (3) Docker Control System. The docker and dockee models are based on simple planar orbital dynamics equations using a spherical earth gravity model. The docker control system is based on a phase plane approach to error correction.

The simulation development took advantage of the hierarchical nature of the development environment by reusing model structures. For example, the translation dynamics model for the Docker is the same as the Dockee - on orbit masses driven either by thruster forces or gravity acceleration. Software reuse was also used in the Docker Control System Development.

The simulation was developed in order to support hardware in the loop simulations. This means that any avionics hardware that may be ready for use be integrated into the simulation and tested under real-time conditions. Examples of avionics hardware that may be used include a rendezvous sensor, flight computer, hardware controller units, and navigation sensors. Further, if the hardware elements have software germane to the rendezvous and docking problem, they can be designed, developed and tested within this environment.

An important aspect of the simulation system is how the basic model elements are integrated into the hardware in the loop version of the simulation. Version includes inputs for handcontrollers, image processors, real time simulation computer and avionics flight computer. A powerful interface to drive impressive 3D images has also been developed. The 3D imaging is important not just from the point of view of

understanding what is occurring in the simulation but can also be used to test rendezvous and docking sensors based on video processing.

The simulation as a whole is readily extensible to include other disturbances and effects. These other disturbances will become important during the development of a robust autonomous rendezvous and docking system.

Historical Background:

The development approach taken on this project was developed under an ALS/NLS advanced technology project known as Adaptive Guidance, Navigation and Control Project 2203. The goal of that project was to investigate methods to drive the cost to develop GN&C systems by either making the process of design more efficient and better integrated or by increasing the adaptiveness or robustness of the flight control system so that mission to mission changes are not required. The simulation itself was developed to demonstrate the capabilities RIP to develop spin off applications for the high-energy Centaur upperstage.

Technology Maturity:

Elements of Rapid Integration and Prototyping (RIP) technology is mature enough to be used on production programs today. The integration of these design technologies is the area that needs development.

Test Experience:

The simulation described in this paper/presentation has been developed by the AGNC team in the advanced avionics department of GDSS. It has been operated in real-time. It is currently under further development to support simulation and design studies for autonomous rendezvous and docking.

Sponsorship & Funding:

The Rendezvous and Docking simulation was developed on GDSS discretionary funds during 1990. Enhancements to the simulation model, in particular a rendezvous and docking sensor model is under development funded by a NASA/JSC CRAD. The development methodology and environment (Rapid Integration and Prototyping) concept was defined and developed on the Adaptive Guidance, Navigation and Control Advanced Development Project. The Advanced Avionics group at GDSS plans an IR&D for 1991 that will further develop and enhance RIP capabilities.

Photonic Correlator Pattern Recognition:
Application to Autonomous Docking

Gary W. Sjolander

(303) 971-3257
FAX (303) 977-1921

Martin Marietta Astronautics Group
Denver, Colorado USA

577-19
ABS ONLY
N93-22803
p. 3

Technology and Application--Optical correlators for real-time automatic pattern recognition applications have recently become feasible due to advances in high speed devices and filter formulation concepts.

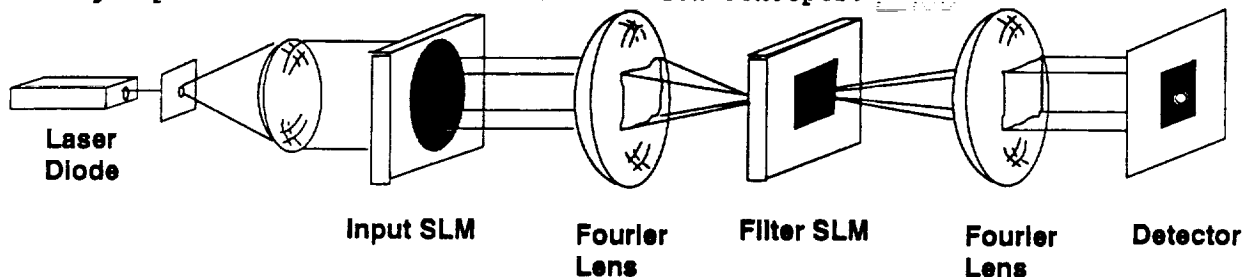

Figure 1. Typical optical correlator architecture.

The most common correlation system architecture is shown in Figure 1. This system correlates the Fourier transforms of an input pattern and a stored pattern 'filter' and passes the result to an optical detector. A significant peak on the detector indicates a high confidence match between the input pattern and the database pattern. The peak amplitude is the key indicator for probability of detection and is normalized for specific applications. Information also exists in the sidelobe structure of the correlation peak, information which has been shown to be useful to a neural network in controlling the performance of the optical processing module. The input scene (docking patterns or spacecraft structure) can be binary, ternary (3-level) or gray-scale (256 levels). Lenses perform the required Fourier transforms, and the filter is written onto a spatial light modulator (SLM) placed in the filter (frequency) plane between these lenses. Recent improvements in the switching speed and resolution of SLMs now allow implementation of filters with these devices such that the operation of the total correlator is in real time.

The the optical correlation process provides a two dimensional pattern recognition capability in real time (30 to 500 frames per second) that has application for both cooperative and non-cooperative docking. The example shown in Figure 2 illustrates a Space Transfer Vehicle scenario for autonomous docking of the Lunar Excursion Vehicle with the Lunar Transfer Vehicle at low lunar orbit. A variety of docking patterns have been used or investigated, but the "star" pattern (Jet Propulsion Laboratory) appears to be ideal for optical correlation due to its insensitivity to scale and rotation.

Autonomous Docking: Optical Correlator

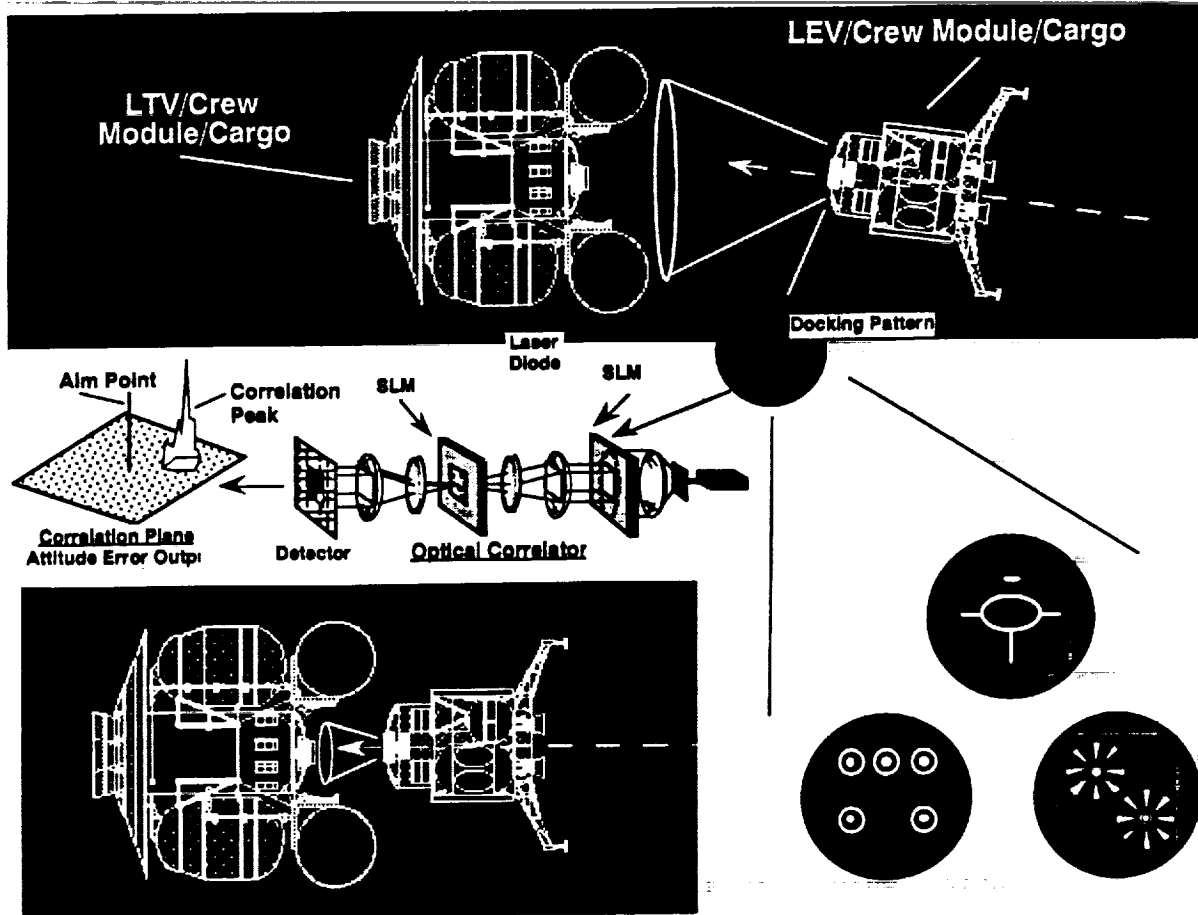

Figure 2. Optical correlator assisted docking.

History of Martin Marietta Photonic Systems--Since 1988, The Martin Marietta Corporation has committed to the development and implementation of advanced optical correlators (photonic correlators) based processing systems that will meet the demands of future high data throughput. To meet this objective, the corporation has assembled a team of recognized experts to develop advanced pattern recognition technology. This team is comprised of industrial and university scientists and engineers who are developing optical correlation technology, neural networks, hardware components, and related image processing techniques. Team members include the University of Colorado Optoelectronic Computing Systems Center and the University of Dayton Research Institute. Photonic Systems is leading the state-of-the-art in pattern recognition technology that uses coherent optical processing.

Maturity--The Photonics team is currently performing a Government contracted effort to build, evaluate, and flight test a ruggedized optical processing module for pattern recognition. In addition, we are building four compact optical systems for mobile platforms and three new systems for table-top use. These systems perform pattern recognition on diverse applications ranging from military target recognition to signal processing to human chromosome identification. The Photonics Systems Center was established to transfer this

highly promising pattern recognition technology into systems applications. This Center possesses every state-of-the-art electro-optical component for advanced image processing and over 300 software programs dedicated to simulation of potential application of optical processing to pattern recognition. In the near future, our photonics technology will be combined with system level simulation capability utilizing our robotics laboratory and the Space Operation Simulation Laboratory.

The need for optical correlators that are used outside the laboratory has stimulated many advances in optical correlator architectures. The first major advance was the use of a telephoto lens system to shorten the correlator optical path from 4 meters to 1 meter. This resulted in practical implementation of the optical correlators to realistic table-top applications.

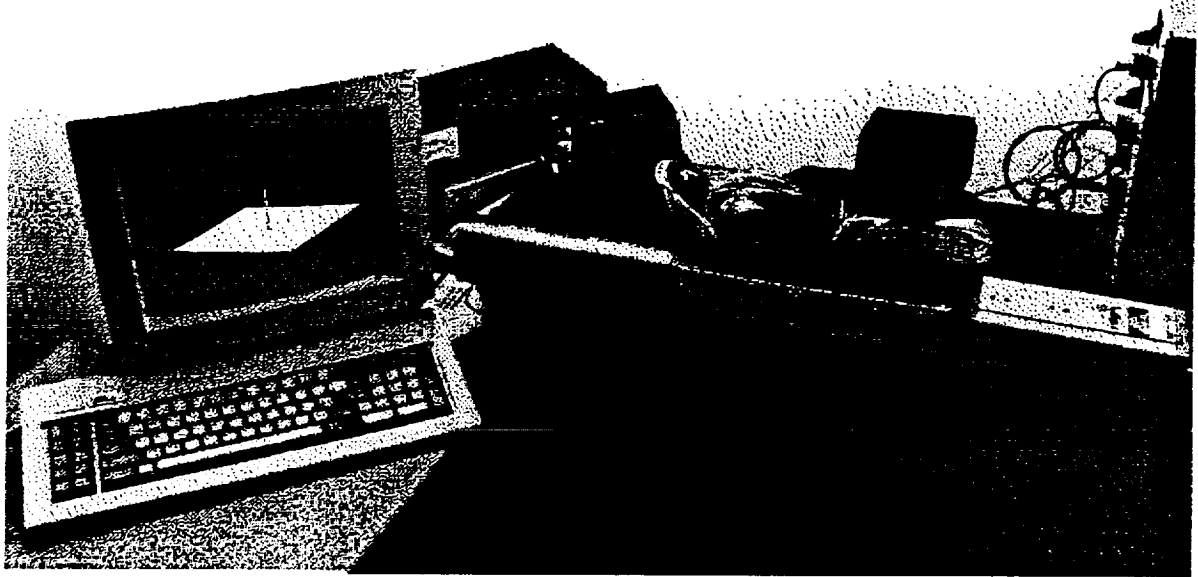

Figure 3. Martin Marietta programmable portable correlator.

During 1990, we developed the first portable programmable correlator, which has a length of 11.5 inches from the input SLM to the detector plane and is shown in Figure 3. This portable correlator uses magneto-optic spatial light modulators (MOSLMs) and is capable of operating on binary or ternary input images at a 500 frame per second filter rate.

In 1991, Martin Marietta developed a new compact correlator that uses ferroelectric liquid crystal (FLC) spatial light modulators capable of frame rates in excess of 1,000 Hz. This breadboard unit has been further refined and a prototype unit is being assembled. The FLC SLMs being used are reflective and electrically addressed. The projected capability for FLC SLMs is for 512x512 pixel frames operating at 10,000 frames per second by the end of 1992.

Source/sponsorship--The initial source of funding for photonics technology was provided by IR&D and corporate monies. This investment resulted in a DARPA contracted activity just under \$3M over a period of 32 months that is part of their Transfer of Optical Processing to Systems (TOPS) program.

1. The first part of the document discusses the importance of maintaining accurate records of all transactions.

2. It is essential to ensure that all data is entered correctly and consistently.

3. Regular audits should be conducted to verify the accuracy of the information.

4. The second section covers the various methods used to collect and analyze data.

5. These methods include surveys, interviews, and focus groups.

6. Each method has its own strengths and weaknesses, and they should be used in combination.

7. The third part of the document describes the process of data analysis.

8. This involves identifying patterns, trends, and correlations in the data.

9. Statistical tools and software are often used to facilitate this process.

10. The final section discusses the importance of reporting the results of the analysis.

11. Clear and concise communication is key to ensuring that the findings are understood.

12. The report should include a summary of the key findings and recommendations.

13. It is also important to discuss the limitations of the study and any potential biases.

14. The document concludes by emphasizing the value of data-driven decision making.

15. By following these guidelines, organizations can ensure that their data is used effectively.

578 13
N 93 - 22304
7135 ONLY
146 788--

SIMULATION MODELS FOR AUTONOMOUS RENDEZVOUS AND CAPTURE

Nick G. Smith, Jim A. McKinnis, Sid M. Early
Martin Marietta Civil Space and Communications
Denver, Colorado
Phone: (303)971-6873
FAX: (303)977-1893

P-3

Autonomous rendezvous and capture (AR&C) is a critical space technology with significant application to a variety of missions. Martin Marietta Astronautics Group (MMAG) has been developing AR&C technical capability in support of several recent NASA contracts. AR&C for the Mars Rover / Sample Return (MRSR) mission has been studied through a contract with Johnson Space Center. Incorporation of AR&C in the Space Transportation Vehicle (STV) lunar mission has been studied through a contract with Marshall Space Flight Center. MMAG has also been developing AR&C simulation capability under independent research and development studies. Simulation development has been driven by two goals - comprehensive software simulation of the autonomous rendezvous and capture mission from launch to final capture, and integration of an overall software and hardware simulation to support an AR&C flight demonstration. This presentation will highlight the AR&C software simulation tools, and analysis results from their application to the STV lunar mission. Plans for an integrated software and hardware simulation will also be summarized.

Comprehensive software simulation of autonomous rendezvous and capture must include ascent, orbital phasing, terminal rendezvous, station keeping, approach, and capture. Software tools have been developed to simulate each of these AR&C mission phases. POST, a program to optimize simulated trajectories, is a long-standing tool recognized industry wide for optimizing launch vehicle ascent trajectories. GENREN, an orbital phasing program, has been used on MRSR, Satellite Servicer System (SSS), Manned Mars Mission (MMM), and STV studies to generate parametric performance data. SEART, simulation and error analysis of rendezvous trajectories, has been used to perform sensor evaluations and sensitivity analyses for MRSR, SSS, MMM, and STV studies. PACS, a proximity operations and capture software simulation, has been derived from the high-fidelity, real-time, hardware-in-the-loop simulation in Martin Marietta's Space Operations Simulation (SOS) Laboratory.

These tools have been and are currently being used to provide parametric performance data for the STV lunar mission study. POST provided insight into the trade between launch window timing, ascent maneuvering, and on-orbit maneuvering to support autonomous rendezvous and capture for a dual launch STV configuration. GENREN was used to generate STV orbital phasing parametrics for evaluating alternative orbital phasing techniques. SEART examined STV terminal rendezvous options with a detailed Monte-Carlo analysis. Figure 1 shows the in-plane, target-relative trajectory dispersions from the Monte-Carlo study for terminal phase rendezvous between circular orbit altitudes of 260 and 295 km, using a Shuttle-type radar sensor. PACS is currently being used to perform trade studies of attitude control systems, guidance and navigation algorithms, on-board processors, and close-range sensors to support the STV lunar mission study. Figure 2 displays a typical propellant and ΔV time history for an approach from 300 m in front of the target vehicle.

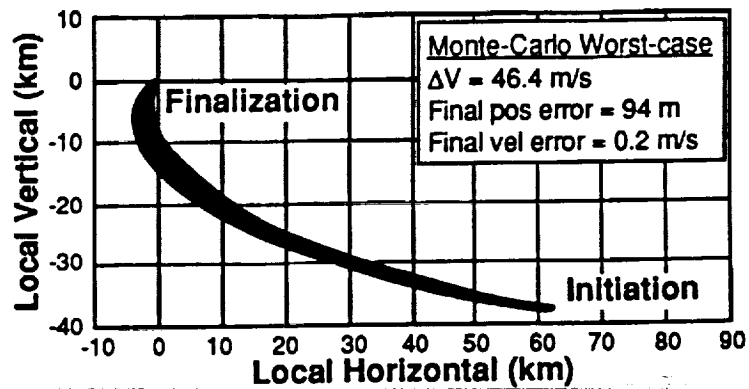

Figure 1 - LEO target-relative terminal rendezvous profiles (100 trajectories)

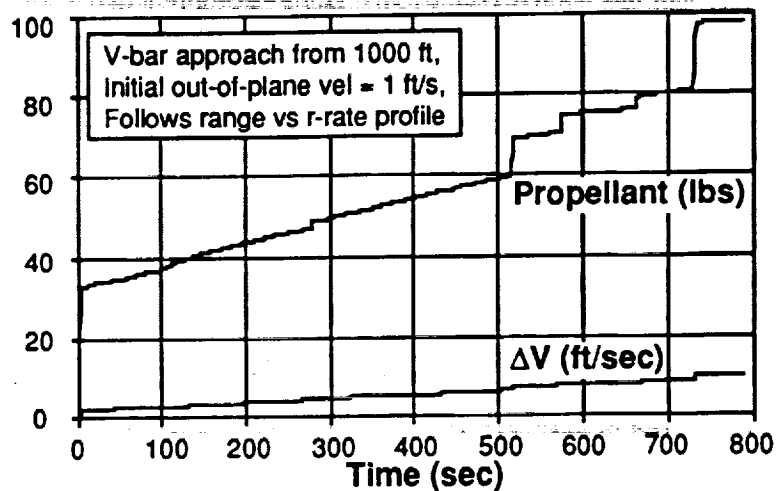

Figure 2 - Approach propellant and ΔV time history

In addition to maintaining a comprehensive set of software tools, Martin Marietta is committed to expanding our current hardware demonstration capability by integrating the critical AR&C technologies into a single, high-fidelity, real-time hardware/software simulation. This simulation will provide a test-bed not only for developing the key AR&C technologies, but for providing proof-of-concept for AR&C flight systems as well. Table 1 highlights the key technologies to be integrated in the AR&C demonstration at Martin Marietta. The SOS Lab will facilitate development of autonomous operations, including supervised autonomy to allow for operator intervention if required. The SOS Lab will also house range sensors and perform target image processing for the integrated simulation. Docking mechanism evaluation may also be performed in the SOS Lab. The Avionics Lab will provide IMU, star tracker, and CPU hardware and software simulation capability. The Robotics Lab will select appropriate computer vision algorithms for target recognition and pose estimation. Evaluation of capture techniques and hardware (berthing and docking) will be performed in the Robotics Lab. The Robotics Lab may also develop neural networks and model-based reasoning methods for sensor fusion, path planning, and optimization. The Photonics Lab will examine hardware and software for

application of advanced image correlation and processing to support AR&C requirements. And finally, the Propulsion Lab will provide hardware and software simulation of ACS hot and cold gas thrusters. These labs will be connected with a fiber optic network to support the real-time, high-fidelity simulation of key AR&C elements.

Table 1 - Integrated AR&C hardware and software simulation

Facility	Key Technology
SOS Lab	Autonomous operations, range sensor, image processor, docking mechanism
Avionics Lab	Inertial measurement unit, star tracker, central processor unit
Robotics Lab	Computer vision, berthing mechanism controls, docking mechanism dynamics, neural networks, model-based reasoning
Photonics Lab	Advanced image correlation and processing
Propulsion Lab	Attitude control system hot and cold gas thrusters

In summary, Martin Marietta has developed a comprehensive AR&C software and hardware simulation capability. The software capability provides for simulation of each AR&C mission phase, including launch, orbital phasing, terminal rendezvous, and capture. The hardware simulation capability provides for examination of autonomous operations, sensors, processors, and capture mechanisms. These tools will be integrated into a single, real-time, high-fidelity hardware/software simulation that will provide an environment for developing AR&C technologies and a test-bed for validating AR&C flight concepts.

THE UNIVERSITY OF CHICAGO LIBRARY

1000 S. EAST ASIAN LIBRARY

5408 S. UNIVERSITY AVENUE

CHICAGO, ILLINOIS 60637

TEL: 773-936-3000

WWW.CHICAGO.LIBRARY.EDU

UNIVERSITY OF CHICAGO PRESS

549-13
- ABS. ONLY
N93-22309
P-3

Automating an Orbiter Approach to Space Station Freedom to Minimize Plume Impingement

by Peter T. Spehar of Lockheed Engineering & Sciences Co. Phone- (713) 333-6540 Fax- (713) 333-6908 and T. Quan Le of NASA-JSC Phone- (713) 483-8304 Fax- (713) 483-6134.

Technical

Space shuttle orbiter Reaction Control System (RCS) plume impingement during proximity operations with Space Station Freedom (SSF) is a structural design driver for the SSF solar panels and radiators. A study underway at the Johnson Space Center (JSC) is investigating whether the use of an automated approach controller could result in the reduction of plume impingement induced loads during orbiter approach to SSF. Ongoing real time man-in-the-loop (MIL) simulations of an orbiter approaching SSF show that orbiter trajectory control can vary significantly from one pilot to the next. This variation is a cause for concern since current analyses predict that plume impingement loads resulting from MIL orbiter approaches may exceed the solar panel and radiator load limits. The use of an automated approach controller is expected to reduce peak loads by both minimizing orbiter translational jet firings in certain directions and controlling the frequency at which they occur during various phases of the approach.

An automated glideslope approach controller was implemented into the orbiter's Guidance Navigation and Control (GN&C) system in Lockheed's multi-vehicle Proximity Operations Simulator (POS) to control a +Vbar approach of the orbiter to the SSF. Orbiter approaches are also being flown by astronaut and engineering pilots in the real time MIL Systems Engineering Simulator (SES) at JSC. Both the MIL and automated approach simulations are initiated with dispersions in orbiter position and velocity two minutes prior to +Vbar arrival in the manual trajectory control phase of the rendezvous. In this phase, the orbiter approaches from below and in front of SSF with a nominal +Vbar intercept target point range of 400 feet. RCS jet firing histories from the MIL SES runs and automated POS runs are recorded and used to drive high fidelity plume impingement and structural models of SSF so that a structural load comparison can be made.

P. T. Spehar, T. Q. Le

The current groundrules for a nominal orbiter +Vbar approach to SSF require that the orbiter's attitude is tail to earth, payload bay towards the SSF. The Digital Autopilot (DAP) will be in NORMZ or LOWZ mode. NORMZ mode does not restrict any of the orbiter's 38 primary RCS jets (870 lbf each) from firing during attitude or translational control. LOWZ mode inhibits all jets firing towards SSF, thus reducing plume impingement on SSF. However, it provides very inefficient braking and much more fuel is consumed than when in NORMZ. At a range of 75 feet the DAP transitions from LOWZ to NORMZ.

Proximity operations piloting techniques use a combination of rendezvous radar for range and range rate information; payload bay Closed Circuit Television (CCTV) camera angle triangulation or CCTV monitor overlays for range estimation (range rate by back differencing); and the Crew Optical Alignment Sight (COAS) for bearing information. The rendezvous radar is quite noisy and has a minimum range limit of 80 feet for tracking small targets. Performance when tracking a structure as large as SSF may be degraded, but analysis is not yet complete. An orbiter-based laser ranging device would provide the best information and is required for an automated orbiter approach. The addition of a laser is currently being debated.

The glideslope approach controller works by periodically calculating the delta-v required to maintain the orbiter on a trajectory with a constant glideslope angle. The equations for the controller are derived from the Clohessy-Wiltshire (C-W) equations. The glideslope controller requires accurate navigation and therefore we assume that an orbiter-based laser sensor provides the navigation with measurements of range, range rate, and bearing angles.

Preliminary results are promising. The controller can reduce the amount of fuel consumed in proximity operations, and it can reduce peak plume impingement loads on SSF.

P. T. Spehar, T. Q. Le

Historical

The glideslope controller was first developed by T. Quan Le in 1986. The POS is a high fidelity multi-vehicle integrated GN&C simulation which currently contains an orbiter and a space station vehicle. The SES has been used as an engineering, astronaut training, and orbiter procedures development tool for many years.

Sponsorship

This work was supported by the Guidance and Prox Ops section of the Navigation & Guidance Systems branch of the Navigation, Control, & Aeronautics division at the Johnson Space Center.

P. T. Spehar, T. Q. Le

100

THE UNIVERSITY OF CHICAGO LIBRARY

100

100

THE UNIVERSITY OF CHICAGO LIBRARY



CONTACT DYNAMICS TESTING OF AUTOMATED THREE POINT DOCKING MECHANISM

Christopher J. Spitzer



Federal Systems Division
1 Space Park Bldg. R11/1850
Redondo Beach, CA 90278
(213)812-2598 Phone
(213)812-8016 FAX

N 93 ~~5822306~~

ABS ONLY
146790

P-1

Statement of technical details of the capability being described

TRW has conducted an extensive Contact Dynamics Test Program (CDTP) of the Three Point Docking Mechanism (TPDM). The CDTP tested the ability of the TPDM latches to capture and automatically dock to target spacecraft. The target selected was the Hubble Space Telescope (HST). Mock ups of the TPDM with its three latches and the docking interface of the HST were constructed at the Marshal Space Flight Center (MSFC) in Huntsville, Alabama for use in the tests. The tests were performed at the Flat Floor and Six Degree of Freedom (6-DOF) facilities at MSFC.

History of the origins and evolution of the capability

The CDT took place in four stages. The first stage included tests of one and two TPDM latches on the Flat Floor Facility. These tests results were used to validate the tests which were to be performed on the 6-DOF simulator. Following the flat floor tests, single latch docking simulations were performed in the 6-DOF facility and compared to the Flat Floor results. After these tests, the 6-DOF facility was enhanced to improve its fidelity and the single latch tests were repeated. After verifying the single latch results, the full 3 latch tests were conducted.

The level of maturity of the capability

The 6-DOF test facility has been validated and is fully functional. The 3 latch tests examined numerous design parameters and docking conditions to evaluate the design of the TPDM and its latches, and to validate the ability of the TPDM to capture a target spacecraft.

Test experience and/or experimental results

The 3 latch tests validated the docking capability of the TPDM and several design decisions were made based on test results. Data recorded from these tests included numerical data of positions, velocities, accelerations, sensor states, and latch positions and video tapes of the actual test runs.

Source/sponsorship and current funding estimates

The contact dynamics tests were supported by the MSFC Orbital Maneuvering Vehicle contract. Currently TRW is performing IRAD to conduct automated docking using a three point docking mechanism.

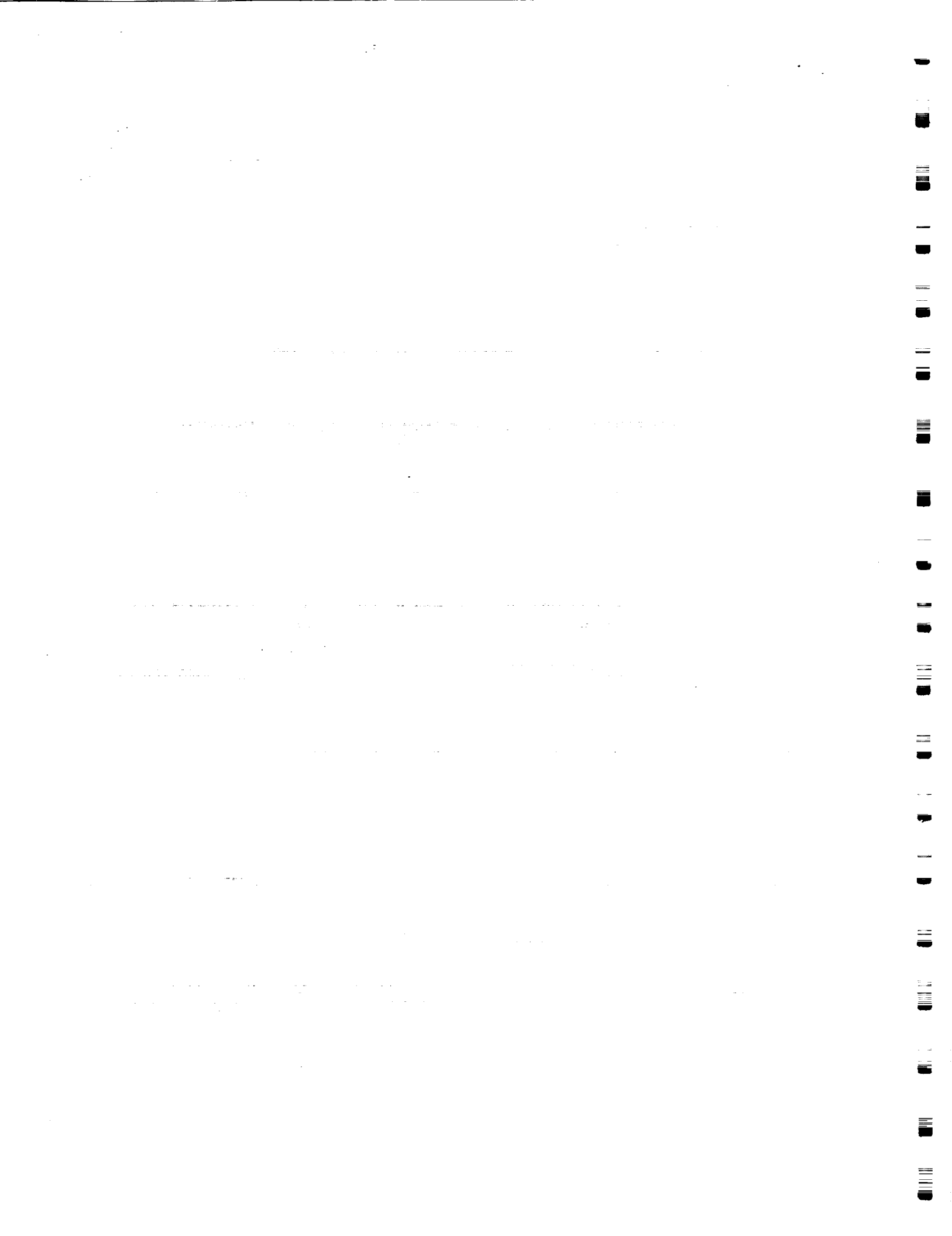

EXPERIMENTAL VALIDATION OF DOCKING AND CAPTURE USING SPACE ROBOTICS TESTBEDS

John Spofford
(303) 971-9319
spofford@den.mmc.com

Eric Schmitz
(303) 971-7144
schmitz@den.mmc.com

William Hoff
(303) 971-2431
hoff@saturn.den.mmc.com

Martin Marietta Civil Space and Communications
Mail Stop 4372, P.O. Box 179
Denver, CO 80201
Fax: (303) 977-4739

581-14
ABS ONLY
1416791

EXTENDED ABSTRACT

p. 3

INTRODUCTION

This presentation describes the application of robotic and computer vision systems to validate docking and capture operations for space cargo transfer vehicles. Three applications are discussed: 1) Air bearing systems in two dimensions that yield high quality free-flying, flexible, and contact dynamics; 2) Validation of docking mechanisms with misalignment and target dynamics; and 3) Computer vision technology for target location and real-time tracking.

All the testbeds are supported by a network of engineering workstations for dynamic and controls analyses. Dynamic simulation of multibody rigid and elastic systems are performed with the TREETOPS code. MATRIXx/System-Build and PRO-MATLAB/Simulab are the tools for control design and analysis using classical and modern techniques such as H-infinity and LQG/LTR. SANDY is a general design tool to optimize numerically a multivariable robust compensator with a user-defined structure. Mathematica and Macsyma are used to derive symbolically dynamic and kinematic equations.

AIR BEARING TESTBEDS

These testbeds provide unconstrained motion in a three degree-of-freedom (DOF) environment with dynamics that closely approximate zero gravity. This allows hardware simulations of contact dynamics with realistic mechanisms, materials, and inertial properties. Large manipulator with link flexibility. The primary flat floor air bearing surface is approximately 20x30 feet and is maintained within a class 10,000 clean area. The surface is made of a two-part epoxy specially formulated for self-leveling properties. A non-contact optical position sensor system is used for performance measurement of all systems operating on the flat floor. An adjacent air bearing surface is located in a thermal chamber for testing hot and cold mechanisms. Smaller air bearing testbeds are located on an optical table with a glass top.

Free-Flying Servicer Vehicle

This testbed is a planar system consisting of a vehicle and two manipulators. The kinetic properties of the servicer testbed are scaled to approximately match those of the Flight Telerobotic Servicer (FTS) mounted on a low-mass vehicle such as the Manned Maneuvering Unit. A high-mass and inertia vehicle is simulated by adding mass to the vehicle frame. The testbed vehicle has three maneuvering DOF: two translational and one rotational. The primary manipulator has four DOF with modular and interchangeable joints and links; link lengths and mass properties can be adjusted to simulate desired manipulator characteristics. The three DOF secondary manipulator has similar capabilities, implemented with flight prototype components. The vehicle has mounting points

for additional test mechanisms and interfaces. These include a docking grapple compatible with the large space manipulator gripper; flexible solar panel appendages; and a generic docking mechanism adapter.

The vehicle has been designed for self contained operation, requiring no external support except for telemetry. Eight cold gas thrusters provide translational and rotational thrust from the onboard nitrogen supply. The thrust level of the thrusters is adjustable. The vehicle also carries a reaction wheel torquer, which consists of a large DC motor coupled to an inertial load. Electrical power is provided by rechargeable batteries to operate the actuators and the processing and control electronics. Air from onboard tanks is used for flotation of the bearings and for the thrusters. The control system is distributed, with the servo-level processing onboard and a wireless communication link for teleoperated and autonomous operation. Accelerometers and a rate gyro measure vehicle motion for closed-loop control. A stereo video camera pair is mounted on a three DOF platform for autonomous vision sensing. The control system is structured hierarchically and incorporates both autonomous vision-based guidance and delayed remote manual control.

Experimental studies have been conducted with the manipulators to examine: 1) inertia matrix decoupling schemes, 2) contact stabilizing controllers, 3) position- and torque-based impedance controllers, 4) the effects of teleoperation force reflection time delays, 5) system identification of large payload mass properties and nonlinear arm dynamics, and 6) control of flexible payloads. The vehicle has been tested on the air bearing floor and is presently receiving upgraded control system electronics.

This testbed provides an integrated validation of vehicle control algorithms, docking sensors, and capture mechanisms. The manipulator may be used as a capture device to avoid an impact type docking procedure. Proximity operations including fly-around can be performed with either a fixed or free-flying target vehicle.

Large Space Manipulator

The LSM testbed is a planar 15 foot long arm with three DOF built to emulate the dynamics of long, crane-like space manipulators such as the Space Shuttle RMS, the Space Station RMS and the (future) Space Crane. In its current configuration with thin flexible links, the fundamental vibration frequency for the arm extended is 0.2 Hz with joints locked. This manipulator also has modular and interchangeable joints and links which can be varied to simulate desired manipulator characteristics. The actuators and link interfaces are identical to the smaller manipulator on the servicer vehicle, allowing a large crane-like arm on the free-flyer.

As a baseline for closed-loop performance, two initial classical control designs have been implemented digitally with a 200 Hz sampling rate. The first controller is a low bandwidth, proportional plus derivative (PD) design using joint position and velocity feedback. Higher closed-loop bandwidth with active control of the arm dominant elastic modes is achieved using an x-y tip position sensor compensation (second-order lead) closed around co-located joint rate feedback loops. Shaping filters are used to gain stabilized the arm higher frequency vibration modes. Future work will demonstrate autonomous capture of a free-flying payload using a vision-based proximity sensor to track the relative position of the end-effector.

With rigid links, this manipulator can simulate relative orbital motion of target vehicle in the orbital plane. In this scenario, the target vehicle is attached to the LSM and the force/position control loop simulates target structural dynamics during docking. This approach integrates the sensing and control aspects of the free-flying vehicle system with realistic relative motion and dynamics of the target.

INTEGRATED TELEAUTONOMY TESTBED

This laboratory contains three commercial 6 DOF electric manipulators whose control systems have been replaced with custom controllers. The largest of these has a reach of several feet with a capacity above 100 lb. Six-axis force/torque sensors are mounted between each manipulator's wrist and end effector. Video cameras are also mounted to the wrist of each manipulator. The control system architecture of this testbed is hierarchical and incorporates servocontrol, trajectory control, path

planning, and task planning layers. Computer vision has been incorporated into the control system for real-time vision-guided manipulation. A multi-level operator interface provides supervisory control of the system at all levels in the controller hierarchy. The servo controllers for the manipulators accept Cartesian position commands from either hand controllers or from a higher-level trajectory generator. The commanded position is modified by an impedance control loop, also known as active compliance, based on the sensed forces and torques.

We have analyzed and simulated the constrained contact dynamics between mechanical components manipulated by robots. These simulation models have been validated using robotic testbeds operating in one, two, and three dimensions. This same capability provides an analytical basis for predicting the operating characteristics of a spacecraft docking system.

This testbed provides the capability to validate the operating regime and performance of docking mechanisms in three dimensions. The mechanisms will be mating at varying velocities with carefully controlled misalignments in position and orientation. The manipulator is controlled with force feedback from the force/torque sensor mounted between the toolplate and the docking mechanism. The force/position control loop can simulate a model of the supporting structure's dynamics. The combined workspace of two manipulators is several feet, allowing moderate free-body reactions to be simulated.

COMPUTER VISION

Accurate estimation of target vehicle position and attitude (*i.e.*, pose) is critical to successful autonomous rendezvous and capture. Computer vision is a sensing technique that can provide accurate pose information at relatively close ranges.

We have developed a variety of experimental and analytic tools to evaluate the accuracy, robustness, and speed of computer vision algorithms running on different processing architectures. We have developed software simulations as well as actual hardware measurement techniques (using laser interferometers and theodolites) to measure the accuracy of camera calibration and pose estimation algorithms. We have integrated a vision system into the NASREM-based Teleautonomy testbed described above, to demonstrate the robustness of vision-guided manipulation tasks. Finally, we have three different image processing systems available to support evaluation of real-time performance: a multiple Digital Signal Processor (DSP)-based system (Androx), a video-rate pipelined system (Datacube), and a massively parallel system with over 12,000 bit serial processors (Martin Marietta's GAPP).

An representative example of our experience in this area was a recent experiment to determine the accuracy of pose estimation from single cameras. We compared five different pose estimation algorithms using real images with very accurate ground truth data. A planar target containing circular markings was moved through a series of positions and measured very accurately (to 0.002" and 0.004°). These images and ground truth data were originally created for the FTS program as part of an effort to develop a visual positioning sensor that would be used to verify the positional accuracy of the robot arm on orbit during Demonstration Test Flight 1. We found that vision is very accurate (better than 0.05" and 0.5°) at very close ranges (2' or less); the translational accuracy scales linearly with range.

By designing appropriate targets (*e.g.*, with high contrast markings), the computational power needed to extract the target features is minimized. In our robotics work, we can estimate target pose at a rate of 10 Hz using a DSP board hosted on a Sun compatible workstation. Faster DSP's, which are available and space qualified, could boost this rate to 30 Hz. This real-time pose estimation capability can be used in either the 2D or 3D testbeds for simulating rendezvous and capture operations.

These capabilities have been developed in the Intelligent Systems and Controls group of our Research and Technology department. Development of the flat floor and air bearing testbeds was done entirely under Martin Marietta internal funding.

[Faint, illegible text, possibly bleed-through from the reverse side of the page. The text is too light to transcribe accurately.]



Proximity Operations Considerations Affecting Spacecraft Design

Steven K. Staas
 McDonnell Douglas Space Systems Company - Houston, Texas
 (713) 283-4264 / MC: MDCB2CHI / FAX: (713) 283-4020

58218
 ABS. ONLY
 N 93-22808
 P-3

Abstract

Background

Experience from several recent spacecraft development programs, such as Space Station Freedom (SSF) and the Orbital Maneuvering Vehicle (OMV) has shown the need for factoring proximity operations considerations into the vehicle design process. Proximity operations, those orbital maneuvers and procedures which involve operation of two or more spacecraft at ranges of less than one nautical mile, are essential to the construction, servicing and operation of complex spacecraft.

Typical proximity operations considerations which drive spacecraft design may be broken into two broad categories; flight profile characteristics and concerns, and use of various spacecraft systems during proximity operations. Proximity operations flight profile concerns include:

- relative approach/separation line
- relative orientation of the vehicles
- relative translational and rotational rates
- vehicle interaction, in the form of thruster plume impingement, mating or demating operations, or uncontrolled contact/collision
- active vehicle piloting

Spacecraft systems used during proximity operations include:

- Sensors, such as radar, laser ranging devices or optical ranging systems
- effector hardware, such as thrusters
- flight control software
- mating hardware, needed for docking or berthing operations

A discussion of how these factors affect vehicle design follows, addressing both active and passive/cooperative vehicles.

Active Vehicle Design Considerations

For proximity operations purposes, an active vehicle may be defined as one which performs translational maneuvers to approach, stationkeep with or depart from another spacecraft. An active vehicle, then, must either be flown by an astronaut onboard, flown by a remotely located pilot, or controlled by an automatic or autonomous flight control system.

Sensors are a critical part of an active vehicle. The ability of a spacecraft to perform proximity operations successfully is dependent on the accuracy of the sensors. With the NSTS Orbiter, for example, accurate range and range-rate information is needed by the

pilot to control the trajectory and exercise control options to minimize plume impingement on the spacecraft being approached or departed from. The rendezvous radar currently provides this information: however, the need for a more precise sensor has led to the study of laser ranging systems and optical ranging devices, which are also applicable to unmanned or autonomous spacecraft. Additionally, sensors must be located on the spacecraft such that an adequate field of view is provided; i.e., no other structure blocks the sensor field of view, and the sensor is oriented in the proper direction.

Flight control hardware and software must also accommodate proximity operations requirements. It is highly desirable for the vehicle to hold its attitude within small tolerances and be able to make fine adjustments to relative translational rates. Fine translational rate adjustment capability is required to ensure that rates compatible with mating hardware specifications are achievable. The size and location of reaction control system thrusters is critical to the vehicle's ability to make fine corrections in velocity, attitude and attitude rate. For example, simulations of the early STS-C unmanned cargo vehicle design showed a need for thrusters at both ends of the vehicle for effective translational control of the vehicle, as full six degree of freedom control was deemed necessary for a vehicle approaching the SSF. A vehicle's flight control software must provide the necessary operating modes for its mission, and should be flexible enough to accommodate I-load changes and further upgrades as needed. Additionally, for automated or autonomous vehicles, the flight software must protect for contingency scenarios, allowing vehicle safing or emergency bail-out procedures as required.

Passive/Cooperative Vehicle Design Considerations

For proximity operations purposes, a passive vehicle may be defined as one which does not perform translational maneuvers, but can (and frequently does) have an attitude control system. The design considerations which apply to passive vehicles mainly involve compatibility with the appropriate active vehicle.

The control system in a passive vehicle, if it has one, must have sufficient control authority to maintain attitude while an active vehicle approaches or departs from it. The passive vehicle will experience disturbances from active vehicle plume impingement and, during mating and demating operations, forces from contact with the active vehicle.

In some cases, control of the passive vehicle by the active vehicle may be necessary to ensure mission success. The capability for the Orbiter to deactivate the SSF control system just prior to manipulator grapple operations is an example: Orbiter manipulator constraints require that spacecraft being grappled may not have their control systems active at that time.

The passive vehicle structure must also be designed for proximity operations. Mating hardware must be compatible, and must be located such that mating and demating can be achieved without other contact between the vehicles. In addition, equipment to be serviced or replaced must be accessible either by remote manipulator or by an astronaut.

History of Spacecraft Performance Assessment

Our early experience with shuttle proximity operations flight design, beginning in the late 1970's, led to the development of our orbital simulation programs for analysis of proximity operations, starting with two-vehicle (orbiter and payload) batch-mode simulations on a desktop calculator. By adding real-time, man-in-loop capability to these tools, the basis for our current analysis capability was established. These simulation tools

were used to design proximity operations techniques and procedures, starting with STS-7, the first dedicated Orbiter proximity operations flight, and are in use currently to assess trajectories, docking and berthing feasibility, spacecraft plume impingement and surface contamination, visual and sensor requirements, and to do preliminary development of flight techniques. Our simulation tools have been modified and used to simulate and analyze various other spacecraft, including the OMV, STS-C, the Assured Crew Return Vehicle (ACRV), the Man-Tended Free-Flyer (MTFF), the Tethered Satellite System (TSS) and the Simplified Aid For EVA Rescue (SAFER). Current work on the Space Station Freedom program includes analysis of Orbiter/SSF interaction during docking and berthing operations, assessment of Orbiter plume-induced loads on the SSF solar arrays, and the establishment of a requirement for a direct Orbiter-to-SSF radio-frequency (RF) command and telemetry link for Orbiter control of unmanned SSF assembly stages.

Summary

Spacecraft which must interact with other space vehicles must incorporate capabilities and features in their design to address the unique requirements of on-orbit proximity operations. Our experience in analyzing proximity operations and vehicle performance for a variety of manned and unmanned spacecraft over the past 14 years has shown that the suitability of a vehicle for proximity operations is linked to how well the vehicle design reflects the sensor accuracies and controllability it will require during actual operations.



THE MSFC SPACE STATION / SPACE OPERATIONS MECHANISM TEST BED

William G. Sutton : Marshall Space Flight Center, EB44, (205) 544-3824

Patrick A. Tobbe : Control Dynamics Co., (205) 882-2650

FAX (205) 882-2683

N 93-22809

ABS ONLY
1467 93

P. 3

The Space Station/Space Operations Mechanism Test Bed consists of a hydraulically driven, computer controlled Six Degree-of-Freedom Motion System (6DOF), a six degree-of-freedom force and moment sensor, remote driving stations with computer generated or live TV graphics and a parallel digital processor that performs calculations to support the real time simulation.

The function of the Mechanism Test Bed is to test docking and berthing mechanisms for Space Station Freedom and other orbiting space vehicles in a real time, hardware-in-the-loop simulation environment. Typically, the docking and berthing mechanisms are composed of two mating components, one for each vehicle. In the facility, one component is attached to the motion system, while the other component is mounted to the force/moment sensor fixed in the support structure above the 6DOF. The six components of the contact forces/moments acting on the test article and its mating component are measured by the force/moment sensor. The force/moment sensor has a dynamic range from less than 1 lb to over 6000 lbs and is interfaced to the real time Alliant computer system. The hydraulic system is capable of generating over 100,000 lbs of force. Each actuator has a closed loop position bandwidth measured at 7 Hz. The test articles are protected with hardware and software safety devices.

The equations of motion describing the berthing or docking process are driven by the measured contact forces/moments, vehicle control system actuators, gravity, and other forcing functions pertinent to the process. These equations are solved numerically for the relative motion between the docking/berthing mechanisms in real time. Actuator leg length commands are computed for the motion system such that the relative motion between the mechanism components in the facility duplicates that of the numerical simulation. In this manner, the general case of two objects moving through space is fully represented.

The numerical docking simulation mathematically models two flexible

bodies moving freely in space. The bodies are acted on by mechanism contact and capture forces/moments, gravity, and vehicle control actuators and thrusters. The code is modular and easily accommodates user defined vehicle control routines. The simulation will also allow man-in-the-loop studies using a control station and a test subject responding to computer driven instruments and computer generated/video images. The non-linear equations of motion were derived using the Boltzmann-Hamel equations, accounting for flexibility through the assumed modes technique.

The numerical berthing simulation is based on a model of the orbiter Remote Manipulator System (RMS). The berthing process is defined by the following scenario. An astronaut will grapple the payload using the RMS and position it within the capture envelope of the berthing mechanism. The RMS will then be placed in limp mode (i.e. power to all motors will be cut off). Capture latches on the active half of the mechanism will reach out, hook the passive mechanism, and pull it towards the active half, thereby back driving the motors of the RMS simulation. The RMS model consists of the controlling flight software modules, joint servo models, and arm/base vehicle dynamics models. The flight software calculates joint rate commands based on tip position and orientation errors. Motor shaft rate errors and simple DC motor models produce resulting actuator torques for each joint. The measured contact forces/moments and simulated motor torques drive the equations of motion describing the flexible RMS and base vehicle. The RMS/base vehicle model is composed of a chain of flexible bodies coupled by torsional springs. These springs simulate flexibility in the joints and the gear boxes between the motors and the joint drive shafts. Body flexibility is incorporated into the equations of motion using a component mode synthesis technique. The payload and base vehicle may also be flexible. The resulting equations are valid for large rotations and translations of each body. Friction/stiction is also included at each joint and motor.

The Mechanisms Test Bed has previously been used to test several docking and berthing mechanisms, ranging in size from a few pounds to large mechanisms weighing in excess of 3500 pounds. These mechanisms include :

- Docking/Berthing Mechanism for Skylab reboost.
- Berthing Mechanism for a 25 KW power module.
- Space Telescope Keel Latch
- RMS Arm End Effector

- Prototype Space Station Docking/Berthing Mechanism with long reach capture latches and electro-mechanical load attenuation devices.
- Docking Mechanism for Orbital Maneuvering Vehicle.
- Prototype Space Station Freedom Docking/Berthing Mechanism

This paper will describe the facility, simulation capabilities, and past test projects.

Control Dynamics has been sponsored in this effort by MSFC EB44 under contracts NAS8 - 36570 and NAS8 - 38771.

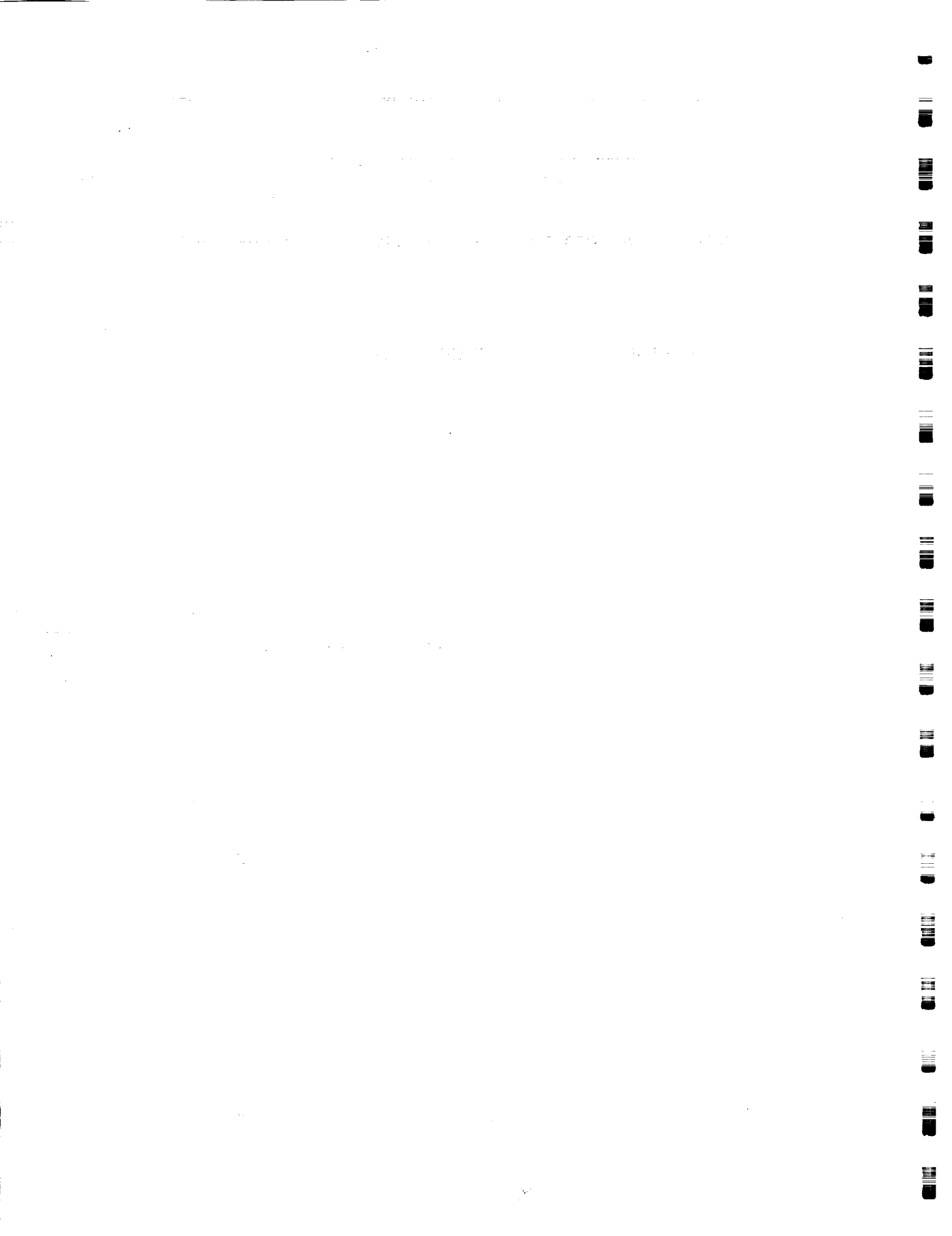

U.S. Automated Rendezvous and Capture Review
Category 2 - Software Systems

DE4-13
ABS ONLY
146794
N 93 - 223 10
p-1

Abstract Title: The Role of Smart Systems in Rendezvous, Close Proximity Operations and Docking Maneuvers

Author: Gerard P. Szatkowski, PhD

Affiliation: General Dynamics, Space Systems Division
P.O. Box 85990, San Diego, Ca. 92138-5990
MZ 24-8660

Technical Details:

Various missions scenarios (Space Station logistics, LEO & GEO services and SEI operation) will involve flexibility in mission management. This means operations will be one or a combination of: autonomous, supervised autonomous and machine aided manual control. Smart Systems will likely play a significant role in making these missions successful from a safety/reliability perspective, and less costly from an operations perspective. This does not imply that Smart Systems need to be super sophisticated. On the contrary, Smart Systems have been described as automated intelligence that if a man had done it wrong, it would be considered stupid. The first part of this paper will describe the types of Smart System techniques involved in AR&CC, their specifications, duties and interactions.

Next will be a discussion of the work performed at GD under the auspice of the ALS Program to further Expert Systems applications imbedded in the control process, NASA/JSC CRAD and other related IRAD projects. This will include issues pertaining to: integration, speed, knowledge encapsulation and cooperative systems.

Finally, a brief description will be offered to outline the major obstacles for the acceptance of Smart Systems in critical applications. Some progress to date in the industry in this regard. And current directions to surmount these problems.

The following information was obtained from the records of the
 Department of the Interior, Bureau of Land Management, on
 the subject of the above-captioned matter.
 The Bureau of Land Management has advised that the
 land described in the above-captioned matter is
 owned by the United States of America and is
 located in the State of California.
 The Bureau of Land Management has advised that the
 land described in the above-captioned matter is
 owned by the United States of America and is
 located in the State of California.
 The Bureau of Land Management has advised that the
 land described in the above-captioned matter is
 owned by the United States of America and is
 located in the State of California.
 The Bureau of Land Management has advised that the
 land described in the above-captioned matter is
 owned by the United States of America and is
 located in the State of California.
 The Bureau of Land Management has advised that the
 land described in the above-captioned matter is
 owned by the United States of America and is
 located in the State of California.



ABSTRACT

585-18
ABS ONLY
N 93-22811

Guideline Requirements for Serviceable Spacecraft Grasping/Berthing/Docking Interfaces Based on Simulations and Flight Experience (Survey Paper)

Allen B. Thompson, PE¹
Martin Marietta
Phone: (303)977-6037
FAX: (303)977-1893

P-1

As space vehicles and structures become larger and more complex, the development of systems to assist humans in assembling, operating, maintaining, and performing space rescue or retrieval of these vehicles and structures becomes increasingly important. With the diversity of international spacecraft, both manned and unmanned, planned to be in orbit in the not too distant future, a set of guidelines for berthing and docking subsystems is mandatory if servicing, resupply and retrieval is to become practical on an international level. Successful interaction between these space systems, and with ground and/or space-based humans, requires standardized and effective operational interface designs, particularly with respect to space grasping/berthing/docking interface mechanisms. This paper defines the spacecraft mechanical interfaces necessary to create a standard dynamic envelope for joining two free-flying spacecraft in a 'hard' berth or dock with each other in space.

A review was made of past space flights and dynamic simulations dating back to 1962 to obtain necessary parameters and their values for successful manually controlled and autonomous spacecraft docking/berthing. The various spacecraft docking/berthing mechanisms and concepts are illustrated along with their dynamic capture and impact tolerances including maximum contact velocity along the approach axis and in the y-z plane; capture linear misalignment tolerances; and maximum capture roll, pitch, and yaw angles. From this data sets of recommended guideline parameters were developed for autonomous and manual impact docking tolerances, non-impact grasping/berthing tolerances (end effectors), berthing contact conditions, and alignment tolerances after rigidizing. Also, detailed requirements were developed for mechanical design interface features, as well as latching, unlatching, and separation tolerances. This data was drafted in the form of a proposed ANSI Standard guideline, reviewed and added to by members of the committee representing several spacecraft manufacturers, NASA, and the USAF, and a consensus was reached.

By defining the active parameters and basic groundrules which all spacecraft designed for docking or berthing should meet, a high level of cross program interoperability and interchangeability will result and lead to the development of standardized and effective operational designs.

¹ Chairman of the Mechanical Interfaces Committee of the NASA-JSC Space Assembly and Servicing Working Group Interface Standards Committee (SASWG-ISC) under the direction of James S. Moore and Charles T. Woolley of the NASA-JSC New Initiatives Office.

AUTOMATIC RENDEZVOUS SYSTEM TESTING AT THE FLIGHT ROBOTICS
LABORATORY

N 93-522312

Patrick A. Tobbe : Control Dynamics Co. (205) 882 - 2650
Fax (205) 882 - 2683

ABS ONLY

146796

Charles B. Naumann : Control Dynamics Co.

p- 2

The Flight Robotics Laboratory of the Marshall Space Flight Center provides sophisticated real time simulation capability in the study of human/system interactions of remote systems. The facility consists of a four thousand square foot precision air bearing floor, a teleoperated motion base, a dynamic overhead target simulator, a remote operator's work station, and various simulation mock ups. This paper will describe the use of the overhead manipulator to study the performance of two automatic rendezvous systems in a real time hardware-in-the-loop simulation. The candidate systems were to be used with the Orbital Maneuvering Vehicle and a servicing satellite for the Polar Platform.

The Dynamic Overhead Target Simulator (DOTS) is an eight degree of freedom, heavy duty electric manipulator capable of traversing over the entire air bearing floor. The system is composed of a precision overhead X-Y crane to which a six degree of freedom robot arm is mounted. A VAX computer is used in real time to convert arm tip position and orientation commands into crane position and arm joint velocity commands. These commands are generated through inverse kinematic relationships and digital control laws housed on the VAX. An elaborate real time safety algorithm is also driven by the VAX to perform collision avoidance and joint position and rate limiting.

In the facility, a mock up of the chase vehicle was placed on the arm tip of the DOTS and a target vehicle mock up was fixed at a location on the edge of the air bearing surface. Both automatic rendezvous approaches used a camera system to generate relative range and orientation data between the vehicles which were interfaced to the real time computer system. For the Polar Platform servicing vehicle, a camera system and infrared LED targets were attached to the mock ups. The OMV system made use of a camera system with infrared laser diodes and passive target reflectors.

The control system for the DOTS and a real time dynamic simulation of the mating vehicles are both on the VAX computer network. The simulation models two rigid vehicles in orbit which may undergo large translations and rotations. The vehicles are acted on by gravitational effects and control system actuators and thrusters. The output of the range/rate sensor is used by the automatic rendezvous algorithm to compute vehicle control system commands, which act as forcing functions in the equations of motion. The equations of motion are solved numerically for the resulting relative position and orientation between the vehicle interface points. This data is then used to compute manipulator tip position and orientation commands such that the resulting motion between the mock ups matches that of the numerical simulation.

This paper will describe the Flight Robotics Facility of NASA/MSFC, the hardware-in-the-loop simulation configuration, and test results.

Control Dynamics has been sponsored in this effort in part by MSFC EB24 under contract NAS8 - 36570.

THRUSTER CONFIGURATIONS FOR MANEUVERING HEAVY PAYLOADS

Roy K. Tsugawa
Michael E. Draznin



Federal Systems Division
1 Space Park Bldg. R11/2337
Redondo Beach, CA 90278
(213)812-2608 Phone
(213)812-8016 FAX

Richard W. Dabney
NASA
MSFC ED13
Huntsville, AL 35812
(205)544-1473 Phone
(205)544-0236 FAX

N 9 3 5 2 2 2 3 1 3

ABS ONLY

146797

P. 2

Statement of technical details of the capability being described

The cargo transfer vehicle (CTV) will be required to perform six degree of freedom (6DOF) maneuvers while carrying a wide range of payloads varying from 100,000 lbm to no payload. The current baseline design configuration for the CTV uses a forward propulsion module (FPM) mounted in front of the payload and the CTV behind the payload so that the center of gravity (CG) of the combined stack is contained between the thruster sets. This allows for efficient rotations and translations of heavy payloads in all directions; however, the FPM is a costly item, so it is desirable to find design solutions which do not require the FPM. This presentation provides an overview of the work performed in analyzing the FPM requirements for the CTV. Specifically, key issues related to thruster configuration requirements for operating CTV without the FPM throughout the 100,000 lbm payload to no payload range will be highlighted.

In this study, only the reaction control system (RCS) thruster configurations are considered and the orbit adjust engines are not addressed. An important output of this study are viable alternative thruster configurations which eliminate the need for the FPM. Initial results were derived using analytical techniques and simulation analysis tools. Results from the preliminary analysis were used as inputs for our 6DOF simulation. The 6DOF simulation was used to validate our design guidelines and to verify the performance of the thruster configurations.

The CTV missions which are used to evaluate the thruster configurations are 6DOF maneuvers with and without payloads of various weights using heavy, beginning of mission, and light, end of mission CTV mass properties. The mission requirements are expressed in terms of acceleration limits needed for proximity operations and stationkeeping for grappling and subsequent berthing at the space station. We identify the key issues which drive the design of the thruster configurations. All of the configurations which are studied allow for fail operational/fail safe performance.

History of the origins and evolution of the capability

TRW has worked extensively on the problem of 6DOF maneuvering with a heavy payload. Initial work was performed during the orbital maneuvering vehicle (OMV) contract and later work was performed during the Shuttle-C study.

The level of maturity of the capability

The guidelines for vehicle control authority requirements have been established and the analytical tools for studying different control configurations are in use. We have the capability of generating thruster configurations and jet select tables and control loop gains to test different design configurations.

Test experience and/or experimental results

The baseline CTV configuration has been implemented in the 6DOF simulator and we have produced simulation results which validate the analytical predictions. From these simulations, performance characteristics of the thruster configurations with different payloads have been derived. Results show that heavy payload operation is possible with the CTV alone (without the FPM) if attention is paid to the maximum and minimum torque requirements.

Source/sponsorship and current funding estimates

The current heavy payload thruster configuration studies are being funded through the CTV study contract. Past efforts have been funded by TRW IRAD.

588 19
N 93 - 22314
11/25/07
146 798
P - 1

Electro-Optical Rendezvous And Docking Sensors

David J. Tubbs, Lynn O. Kesler, and Robert J. Sirko
Advanced Products Development And Technology Division
McDonnell Douglas Space Systems Company
5301 Bolsa Avenue
Huntington Beach, California 92649

Abstract: Electro-optical sensors provide unique and critical functionality for space missions requiring rendezvous, docking, and berthing. McDonnell Douglas is developing a complete rendezvous and docking system for both manned and unmanned missions. This paper examines our sensor development and the systems and missions which benefit from rendezvous and docking sensors. Simulation results quantifying system performance improvements in key areas are given, with associated sensor performance requirements.

A brief review of NASA-funded development activities and the current performance of electro-optical sensors for space applications is given. We will also describe current activities at McDonnell Douglas for a fully functional demonstration to address specific NASA mission needs.



Concurrent-Scene/Alternate-Pattern Analysis for Robust Video-Based Docking Systems

Suraphol Udomkesmalee

Jet Propulsion Laboratory, California Institute of Technology
4800 Oak Grove Drive, Pasadena, California 91109
(818) 354-0614

589-18
N 9,32-228/15

146799

p-2

ABSTRACT

A typical docking target employs a three-point design of retroreflective tape, one at each endpoint of the center-line, and one on the tip of the central post. Scenes, sensed via laser diodes illumination, produce pictures with spots corresponding to desired reflection from the retroreflectors and other reflections. Control corrections for each axis of the vehicle can then be properly applied if the desired spots are accurately tracked. However, initial acquisition of these three spots (detection and identification problem) are non-trivial under a severe noise environment. Signal-to-noise enhancement -- accomplished by subtracting the non-illuminated scene from the target scene illuminated by laser diodes -- can not eliminate every false spot. Hence, minimization of docking failures due to target mistracking would suggest needed inclusion of added processing features pertaining to target locations.

In this paper, we present a concurrent processing scheme for a modified docking target scene which could lead to a perfect docking system. Since the non-illuminated target scene is already available, adding another feature to the three-point design by marking two non-reflective lines -- one between the two end-points and one from the tip of the central post to the center-line -- would allow this line feature to be picked-up only when capturing the background scene (sensor data without laser illumination). Therefore, instead of performing the image subtraction to generate a picture with a high signal-to-noise ratio, a processed line-image based on the robust line detection technique (Hough transform) can be used to fuse with the actively sensed three-point target image to deduce the true locations of the docking target. This dual-channel confirmation scheme is necessary if a fail-safe system is to be realized from both the sensing and processing point-of-views. Detailed algorithms and preliminary results are presented.

Automatic target recognition and pattern recognition research has been the main focus of Dr. Udomkesmalee for the past five years. The original research was funded by MICOM's research directorate to enhance the target identification and tracking performance of an optical correlator-based seeker system, to be employed in the Optical Precision Deep Attack Missile System (OPDAMS). Transferable technologies to AR&C applications are:

1. Portable/programmable optical pattern recognition hardware -- Optical correlator based on Binary Phase-Only Filters with scalable/rotatable raster scan servo to provide a scale/rotation invariant target identification and tracking system.
2. Pre-processing and post-processing algorithms for optical pattern recognition -- Image processing via Fourier's amplitude modulation and blob detection techniques to enhance the input

scene's object-to-background characteristics; and correlation convolution mask definition to enhance the output correlation image.

3. Correlation spots tracker -- PC-based real-time correlation peak detection system to provide position corrections to the optical seeker's inertial platform.

4. Texture and line segments analysis -- High-speed, feature extraction and low-level recognition to isolate object shape and background using Texture energy transform, Hough transform, and Curvature transform.

5. Scale/rotation estimation techniques for unidentified objects -- Object's shape size and orientation estimation using geometrical moments, Fourier extraction, line and curve signatures.

6. PC-based Image processing system -- Optical correlation simulation and image analysis system based on 386PC, Imaging Tech.'s frame grabber, and Eighteen-Eight Laboratories' Array Processor.

Currently at JPL, we are not funded for AR&C research. However, many of the autonomous vision activities at JPL directly benefit the AR&C technology, and there exists an active desire for participation in this technology transfer. Other applicable AR&C technologies from JPL's GNC are:

1. Spatial, High Accuracy, Position Encoding Sensor (SHAPES) -- laser diodes, CCD, and a picosecond streak tube to provide 3-D position sensing and multiple-target tracking capabilities.

2. CRAF/CASINI's Target Star Tracker -- CCD and processing modules to support Spacecraft attitude determination by locating, identifying and computing the position of guide stars and to assist in platform pointing by locating "reference features" for extended targets.

3. ASTROS II Star Tracker -- High efficiency and accuracy CCD-based tracker with extended targets and multiple target tracking capabilities.

910-17
N 98-223/16
A135 ONLY

**AUTONOMOUS RECONFIGURABLE GPS/INS NAVIGATION AND POINTING
SYSTEM FOR RENDEZVOUS AND DOCKING**

146800
P-2

Triveni N. Upadhyay, Stephen Cotterill
Mayflower Communications Company, Reading, MA 01867

and

A. Wayne Deaton
NASA Marshall Space Flight Center, AL 35812

ABSTRACT

This paper describes the results of an integrated navigation and pointing system software development effort sponsored by the NASA Marshall Space Flight Center through a SBIR Phase II Program. The integrated Global Positioning System (GPS)/Inertial Navigation System (INS) implements an autonomous navigation filter that is reconfigurable in real-time to accommodate mission contingencies. An onboard expert system monitors the spacecraft status and reconfigures the navigation filter accordingly to optimize the system performance. The navigation filter is a multi-mode Kalman filter to estimate the spacecraft position, velocity and attitude. Three different GPS-based attitude determination techniques, namely, velocity vector matching, attitude vector matching, and interferometric processing, are implemented to encompass different mission contingencies. The integrated GPS/INS navigation filter will use any of these techniques depending on the mission phase and the state of the sensors. The first technique, velocity vector matching, uses the GPS velocity measurement to estimate the INS velocity errors and exploits the correlation between INS velocity and attitude errors to estimate the attitude. The second technique, attitude vector matching, uses INS gyro measurements and GPS carrier phase (integrated Doppler) measurements during a spacecraft rotation maneuver to determine the attitude. Both of these techniques require only one GPS antenna onboard to determine the spacecraft attitude. The third technique, interferometric processing, requires use of multiple GPS antennae. In order to determine 3-axis body attitude, three GPS antennae (2 no-coplanar baselines) are required.

In the current implementation, the above three techniques are implemented in a multi-mode filter. The software implementation is chosen such that additional new filter modes and processing techniques can be added easily. One addition to the present configuration modes is in the incorporation of relative navigation mode between two spacecraft - a target and a chaser spacecraft - to demonstrate the

capability of GPS to support autonomous rendezvous and docking.

The navigation and attitude determination filter is implemented in Ada programming language. Object oriented software design is used to lay the foundation for the development of a highly reconfigurable embedded Kalman filter software. The software architecture implements two separate software functions: (1) multi-mode navigation Kalman filter, and (2) knowledge-based contingency mission planner. The reconfigurable feature of the software is derived from the use of a real-time interpretive mechanism to execute code threads stored in linked lists. Each code thread defines a navigation filter mode. An embedded expert system stores and executes the knowledge base in real-time. Facts are stored in a network of cross-referenced lists which connect facts to decision modules.

The paper also presents simulation results of the integrated GPS/INS navigation filter for two filter configurations and predicts the spacecraft navigation and attitude determination performance.

**A Berthing and Fastening Strategy for
Orbital Replacement Units**

5-91-18
ABS ONLY

N 93-22817

P-1

**John Vranish
Edward Cheung**

NASA Goddard Space Flight Center, Greenbelt MD

Research in the area of berthing of Orbital Replacement Units (ORUs) at the Goddard Space Flight Center consists of two major parts. First, we concentrate on the development of a comprehensive fastening strategy that can provide both mechanical as well as electrical connection to the ORU. Second, our efforts in robot collision avoidance and motion planning has led to the development of a state-of-the-art capacitive proximity sensor with associated motion control algorithms. These efforts combine to produce a system that allows safe and reliable machine assisted berthing. Although our main emphasis has been on berthing of ORUs, we believe that some of our results can also be applied to docking.

The Work Attachment Fixture/Work Attachment Mechanism (WAM/WAF) allows the fail-safe mating and demating of the ORU with the robot arm. Sensors that are placed onto the ORU box can be connected through the WAM/WAF and used for collision avoidance due to the built in electrical connectors. The WAM/WAF also enables the robot arm to derive power and data from the spacecraft, and can therefore be used as the primary attachment point or "foot" for the robot.

The "Capaciflector" (capacitive reflector) uses a simple extension of an instrumentation technique for controlling stray capacitances. In this instance a capacitive sensing element, backed by a reflector driven at the same voltage as the sensor, is used to reflect the field lines away from the grounded robot arm towards the intruding object, thus dramatically increasing range (greater than 12 inches with the reflector - one inch without) and resolution.

In addition to the ORU, the sensor has also been placed on the body of robot arm manipulators, allowing them to avoid collisions with unknown objects. In addition, due to the excellent resolution at close range, the sensor has shown to be useful in applications as an imaging sensor to locate reference points.

[Faint, mostly illegible text block]

[Faint, mostly illegible text block]

[Faint, mostly illegible text block]

[Faint, mostly illegible text block]

[Faint, mostly illegible text block]

[Faint, mostly illegible text block]

[Faint, mostly illegible text block]



Fully Autonomous Navigation for the NASA Cargo Transfer Vehicle

James R. Wertz and E. David Skulsky
Microcosm, Inc.[†]

ABSTRACT

A great deal of attention has been paid to navigation during the close approach (≤ 1 km) phase of spacecraft rendezvous. However, most spacecraft also require a navigation system which provides the necessary accuracy for placing both satellites within the range of the docking sensors. The Microcosm Autonomous Navigation Systems (MANS) is an on-board system which uses Earth-referenced attitude sensing hardware to provide precision orbit and attitude determination. The system is capable of functioning from LEO to GEO and beyond. Performance depends on the number of available sensors as well as mission geometry; however, extensive simulations have shown that MANS will provide 100 m to 400 m (3σ) position accuracy and 0.03° to 0.07° (3σ) attitude accuracy in low Earth orbit. The system is independent of any external source, including GPS. MANS is expected to have a significant impact on ground operations costs, mission definition and design, survivability, and the potential development of very low-cost, fully autonomous spacecraft.

Because MANS uses on-board attitude sensing hardware, the additional cost for achieving autonomous navigation will be quite low. A single sensor measures the spacecraft attitude as well as the range to the Earth and the relative positions in the spacecraft sky of the Sun and Moon, thus eliminating or reducing many of the principal bias terms which drive attitude and orbit sensing accuracy. MANS is also capable of accepting data from a range of other sensor types (star sensor, GPS receiver, gyros, and accelerometers) and using this data to further enhance its performance. The sensor data is used to provide position and velocity (orbit) data as well as Earth-referenced attitude. MANS outputs the following data at 250 msec intervals:

- Position and velocity
- Attitude and attitude rate (Earth referenced or inertial)
- Sun vector in spacecraft coordinates
- Ground lookpoint of any spacecraft sensor
- Vector in spacecraft coordinates to another satellite whose orbit is known (requires implementation of minor upgrade)

[†] Microcosm, Inc., 2601 Airport Drive, Suite 230, Torrance, California, 90505
Phone: (213) 539-9444, FAX: (213) 539-7268

MANS incorporates a high-fidelity force model which includes high-order geopotential effects, solar/lunar gravitational disturbances, solar radiation pressure, and atmospheric drag. Multiple data checks are executed to ensure the integrity of the output solutions. The software is written entirely in Ada and can reside in either the sensor processor or a flight computer.

The Microcosm Autonomous Navigation System was developed under contract and both flight hardware and software have been delivered. Flight system development began in mid-1989 and was completed in August, 1991, with on-orbit testing expected in late 1992. A ground-based simulation of MANS was developed concurrently and tests are being made to evaluate system performance in a variety of orbit conditions.

REFERENCES

Chory, M. A., Hoffman D. P., and LeMay, J. L., "Satellite Autonomous Navigation—Status and History," *Proceedings of IEEE PLAN (Position, Location, and Navigation) Symposium*, November, 1986.

Chory, M. A., et al, "Autonomous Navigation—Where We are in 1984," Paper No. AIAA-84-1142-CP.

Tai, Frank, and Noerdlinger, Peter D., "A Low-Cost Autonomous Navigation System," *Proceedings of the 12th Annual AAS Guidance and Control Conference*, Keystone, Colorado, February 4-8, 1989.

Tai, Frank, and Barnes, Robert, "The Dual Cone Scanner: An Enhanced Performance, Low Cost Earth Sensor," *Proceedings of the 12th Annual AAS Guidance and Control Conference*, Keystone, Colorado, February 4-8, 1989.

RELATED PATENTS

Autonomous Spacecraft Controller and Related Method, James R. Wertz, March 15, 1988, U.S. Patent No. 4,730,798.

Autonomous Spacecraft Navigation System, James R. Wertz, Patent Allowed.

Satellite Orbit Maintenance System, James R. Wertz, Patent Pending.

EMPLOYING LIGHTING TECHNIQUES DURING ON-ORBIT OPERATIONS

Charles D. Wheelwright/Jennifer R. Toole
Lockheed Engineering & Sciences Co.
Man Systems/Human Factors Engineering Dept.
Houston, Texas 77058

Phone: 713-333-7815/333-7259
FAX: 713-333-6626

N 93-22319

ABS ONLY

146803

(-1)

ABSTRACT

As a result of past space missions and evaluations, many procedures have been established and shown to be prudent applications for use in present and future space environment scenarios. However, recent procedures to employ the use of robotics to assist crewmembers in performing tasks which require viewing remote and obstructed locations have led to a need to pursue alternative methods to assist in these operations. One of those techniques which is under development entails incorporating the use of suitable lighting aids/techniques with a closed circuit television (CCTV) camera/monitor system to supervise the robotics operations. The capability to provide adequate lighting during grappling, deploying, docking and berthing operations under all on-orbit illumination conditions is essential to a successful mission. Using automated devices such as the Remote Manipulator System (RMS) to dock and berth a vehicle during payload retrieval, under nighttime, earthshine, solar or artificial illumination conditions can become a cumbersome task without first incorporating lighting techniques that provide the proper target illumination, orientation, and alignment cues. Studies indicate that the use of visual aids such as the CCTV with a pretested and properly oriented lighting system can decrease the time necessary to accomplish grappling tasks. Evaluations have been and continue to be performed to assess the various on-orbit conditions in order to predict and determine the appropriate lighting techniques and viewing angles necessary to assist crewmembers in payload operations.

1. The first part of the document discusses the importance of maintaining accurate records of all transactions.

2. It is essential to ensure that all data is entered correctly and consistently.

3. Regular audits should be conducted to verify the accuracy of the records.

METHODS FOR MODELING CONTACT DYNAMICS OF CAPTURE MECHANISMS

Philip Williams, Pat Tobbe and John Glaese: Logicon Control Dynamics Co.
600 Boulevard South, Suite 304
Huntsville, AL 35802
(205) 882-2650
FAX: (205) 882-2683

146804
P-2

In this paper, an analytical approach for studying the contact dynamics of space-based vehicles during docking/berthing maneuvers is presented. Methods for modeling physical contact between docking/berthing mechanisms, examples of how these models have been used to evaluate the dynamic behavior of automated capture mechanisms, and experimental verification of predicted results are shown.

Contact force models have been developed for space vehicles using a technique known as the Method of Soft Constraints. In this method, contact forces are computed for any physical contact between capture mechanism surfaces (i.e., docking rings, alignment guides, capture latches, etc...). The docking/berthing ports are defined as an assemblage of surfaces where each surface is considered a geometric constraint with respect to other port surfaces. Contact force calculations are done in 3-dimensional space when any defined surface attempts to pass through another surface. The generated force is mutually normal to the surfaces in contact and its magnitude is proportional to the depth of penetration. These forces are then used to drive the equations-of-motion of the docking/berthing vehicles.

The Method-of-Soft-Constraints has been applied to the following mechanisms: Apollo Probe-Drogue, RMS End-Effector, Orbital Maneuvering Vehicle Three Point Docking Mechanism (OMV TPDM), and Space Station Docking and Berthing Mechanisms. Models for these mechanisms have been used to predict capture envelopes, contact forces, system dynamic response, and vehicle/manipulator control system performance in the presence of contact forces. Hardware-in-the-loop simulation

results have been generated at the MSFC Six DOF Motion Facility for the RMS End-Effector, OMV TPDM, and Space Station Docking Mechanism. These results compared favorably with those predicted by the analytical model. Results from a hardware test of a single latch version of the OMV TPDM on the MSFC Flight Robotics Laboratory air-bearing floor have also correlated well with analytical and hardware-in-the-loop simulation data.

This paper will describe applications of the Method of Soft Constraints to docking/berthing mechanisms, explain the benefits of an analytical model, and present results from past test programs.

This work has been sponsored by:

MSFC EB44 Contact # NAS8 - 36570

MDAC - MSFC Contact # NAS8 - 36417

Boeing Aerospace & Electronics Contact # HJ2558

U.S. Automated Rendezvous and Capture Capabilities Review
Category 1- Hardware Systems

595-18
N 93-22821
146805
P-2

Abstract Title: AR&D Image Processing System
Author: Cathy Wookey and Bruce Nicholson
Affiliation: General Dynamics, Convair Division
P.O. Box 85357, San Diego, Ca. 92186-5990
MZ 41-6590

Technical Details:

General Dynamics has developed advanced hardware, software, and algorithms for use with the Tomahawk cruise missile and other unmanned vehicles. We have applied this technology to the problem of locating and determining the orientation of the docking port of a target vehicle with respect to an approaching spacecraft. The system described in this presentation utilizes a multi-processor based computer to digitize and process television imagery and extract parameters such as range to the target vehicle, approach velocity, and pitch and yaw angles. The processor is based on the Inmos T-800 Transputer, and is configured as a loosely coupled array. Each processor operates asynchronously and has its own local memory. This allows additional processors to be easily added if additional processing power is required for more complex tasks. Total system throughput is approximately 100 MIPS (scalar) and 60 MFLOPS and can be expanded as desired. The algorithm implemented on the system uses a unique adaptive thresholding technique to locate the target vehicle and determine the approximate position of the docking port. A target pattern surrounding the port is then analyzed in the imagery to determine the range and orientation of the target. This information is passed to an autopilot which uses it to perform course and speed corrections. Future upgrades to the processor are described which will enhance its capabilities for a variety of missions.

Historical Background:

For several years we have pursued the development of systems to perform target detection and recognition, autonomous navigation, and other advanced imaging guidance functions for cruise missiles and other unmanned vehicles. Limitations in available power and volume as well as the need for significant data processing throughput has caused us to develop a family of powerful compact multiprocessor systems. These systems are based on the Inmos Transputer, a 32 bit microprocessor designed for use in multi-processor systems. Transputers can be used to create loosely coupled arrays with each processor having its own local memory and communicating with other processors via high speed serial links. The loosely coupled nature of the array allows it to be easily reconfigured and extended to provide increased processing throughput if required. This allows a flexibility not generally available with bus-based or traditional tightly coupled multi-processor systems.

We have developed several systems based on the above technology. These include our Combat Vehicle VHSIC Integrated System (CVIS) processor designed to meet military temperature and vibration requirements for tanks and other armored vehicles,

flight ready image processing and data collection systems for our Advanced Technology Laser Radar (ATLAS) program, and various other desktop and hardened processors. We have also developed software packages for our processors. These include operating systems and run-time kernals customized for each processor's particular needs. Finally, we have implemented a wide variety of algorithms in several higher order languages. The algorithms perform target detection and recognition as well as guidance, navigation and control functions.

System Testing and Demonstration. All three components of the systems (hardware, software, and algorithms) have been demonstrated and tested in both laboratory and field test environments. Our ATLAS processors, for example, are presently undergoing preliminary flight test evaluation. The CVIS processor was delivered to the Army in 1990 and is being used to develop advanced target tracking and fire control software.

Program Sponsorship. Work on the CVIS processor is sponsored by the Army Research Development and Engineering Center (ARDEC) in Dover, New Jersey. ATLAS work is sponsored by the Armament Directorate of the Air Force Wright Laboratory in Eglin, Fla.

OMIT TO
END

APPENDIX

Listing of Abstract Authors

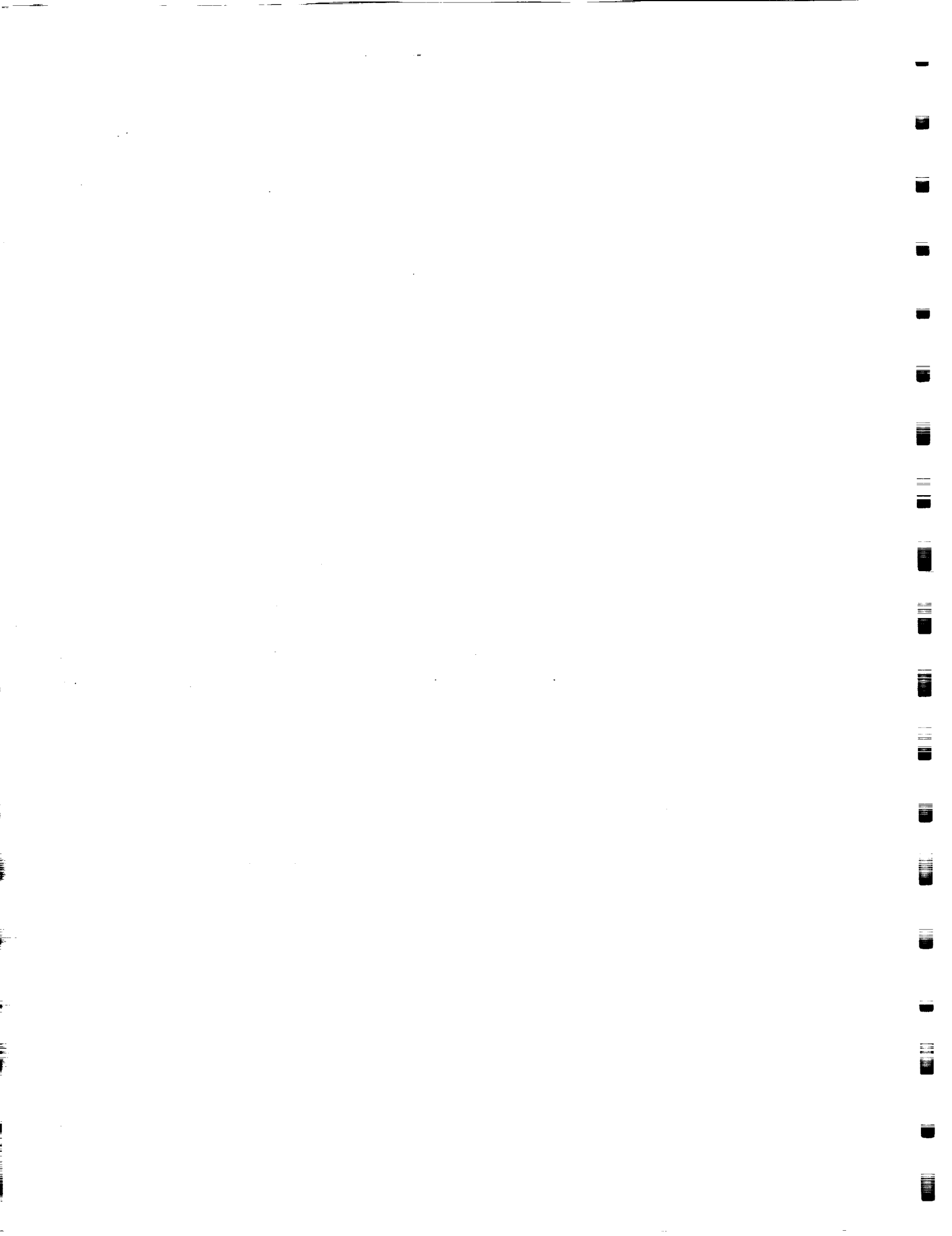

Automated Rendezvous & Capture Review Abstract Authors

<u>LAST NAME</u>	<u>FIRST NAME</u>	<u>ADDRESS</u>	<u>PHONE/FAX NO.</u>	<u>ABSTRACT REF. NOS.</u>
ADLER	JAMES	GENERAL DYNAMICS, SPACE SYSTEMS P.O. BOX 85990 SAN DIEGO, CA 92816-5990		76
ANDERSON	ROBERT L.	TRW FEDERAL SYSTEMS DIVISION 1 SPACE PARK, BLDG R11/2337 REDONDO BEACH, CA 90278	(213) 812-2608 (213) 812-8016	01, 44
ANGELO, JR.	DR. JOSEPH A.	SCIENCE APPLICATIONS INTERNATIONAL 700 BABCOCK STREET-SOUTH (STE 300) MELBOURNE, FL 32901	(407) 676-3102 (407) 676-1628	11
APLEY	DALE	SPACE AUTOMATION AND ROBOTICS CENTER P.O. BOX 134001 ANN ARBOR, MI 48113-4001	(313) 994-1200 (313) 668-8957	16
BALLARD	RICHARD O.	SVERDRUP TECHNOLOGY/MSFC GROUP 620 DISCOVERY DRIVE HUNTSVILLE, AL 35801	(205) 971-9317	02
BANKSTON	CHERYL D.	UNIVERSITY OF ALABAMA MECHANICAL ENGINEERING DEPT HUNTSVILLE, AL 35899		33
BARR	JOSEPH M.	LOCKHEED ENGINEERING & SCIENCES CO. 2400 NASA ROAD ONE EE6HOUSTON, TX 77058	(713) 483-7490 (713) 483-5830	21
BAXTER	J.M.	TRW P.O. BOX 58327 HOUSTON, TX 77258	(713) 333-3133 (713) 333-1875	56
BERENJI	HAMID R.	NASA AMES RESEARCH CENTER MS: 244-17 MOUNTAIN VIEW, CA 94035		03
BERGMANN	E.	THE CHARLES STARK DRAPER LABORATORY 555 TECHNOLOGY SQUARE CAMBRIDGE, MA 02139	617 258-2290	04
BILBRO	JAMES A.	NASA MARSHALL SPACE FLIGHT CENTER EB23 HUNTSVILLE, AL 35812		24

Automated Rendezvous & Capture Review

Abstract Authors

<u>LAST NAME</u>	<u>FIRST NAME</u>	<u>ADDRESS</u>	<u>PHONE/FAX NO.</u>	<u>ABSTRACT REF. NOS.</u>
BITTEL	MICHELLE	LOCKHEED ENGINEERING & SCIENCES CO. 2400 NASA ROAD ONE HOUSTON, TX 77058	(713) 483-7492 (713) 483-5830	05
BOOK	MICHAEL L.	NASA MARSHALL SPACE FLIGHT CENTER EB24 HUNTSVILLE, AL 35812	(205) 544-3550 (205) 544-3801	34, 41
BOYD	M.G.	LOCKHEED ENGINEERING & SCIENCES CO 2400 NASA ROAD ONE/C62 HOUSTON, TX 77058	(713) 483-7708 (713) 483-2162	56
BOYER	K.L.	OHIO STATE UNIVERSITY SIGNAL ANALYSIS & MACH. PERC. LAB DEPT. OF ELECTRICAL ENGINEERING COLUMBUS, OH 43210	(614) 292-7947 292-7596	06
BREHM	DONALD L.	MARTIN MARIETTA ASTRONAUTICS GROUP DENVER, CO 80201		07
BRODY	ADAM R.	STERLING SOFTWARE NASA AMES RESEARCH CENTER MS 262-2 MOFFETT FIELD, CA 94035-1000	(415) 604-3323	08
BRYAN	THOMAS C.	NASA MARSHALL SPACE FLIGHT CENTER EB24 HUNTSVILLE, AL 35812	(205) 544-3550 FAX: (205) 544-3801	01, 09, 34
BUCHANAN	HARRY	NASA MARSHALL SPACE FLIGHT CENTER HUNTSVILLE, AL 35812		10
BUDEN	DAVID	IDAHO NATIONAL ENGINEERING P.O. BOX 1625 IDAHO FALLS, ID 83415-1550	(208) 525-5626 (208) 525-5616	11
BUSHMAN	DAVID M.	NASA MARSHALL SPACE FLIGHT CENTER EP63 HUNTSVILLE, AL 35812	(205) 544-2539	39
CARROLL	MONTY B.	LOCKHEED ENGINEERING & SCIENCES CO. 2400 NASA ROAD ONE HOUSTON, TX 77058	(713) 483-8452	12

Automated Rendezvous & Capture Review Abstract Authors

<u>LAST NAME</u>	<u>FIRST NAME</u>	<u>ADDRESS</u>	<u>PHONE/FAX NO.</u>	<u>ABSTRACT REF. NOS.</u>
CARTER	EDWARD L	LOCKHEED ENGINEERING & SCIENCES CO. 2400 NASA ROAD ONE HOUSTON, TX 77058		65
CASTELLANO	TIMOTHY	NASA AMES RESEARCH CENTER MS: 244-17 MOFFET FIELD, CA 94035	(415) 604-4716	03
CASTILLO	EDUARDO LOPEZ DEL	NASA KENNEDY SPACE CENTER DM-MED-12 KENNEDY SPACE CENTER, FL 32899	(407) 867-4156 (407) 867-2217	13
CAULFIELD	JOHN	UNITED TECHNOLOGIES-USBI P.O. BOX 1900 HUNTSVILLE, AL 35807		51
CHAO	TIEN-HSIN	JET PROPULSION LABORATORY CALIFORNIA INSTITUTE OF TECHNOLOGY PASADENA, CA 91109	(818) 354-8614 (818) 393-4820	14
CHRISTOFFERSON ANN		LOCKHEED ENGINEERING & SCIENCES CO. 2400 NASA ROAD ONE HOUSTON, TX 77058	(713) 333-6377	15
CHU	WILLIAM	C.S. DRAPER LABORATORY MAIL STATION 2B 555 TECHNOLOGY SQUARE CAMBRIDGE, MA 02139	(617) 258-1000 (617) 565-8674	50
CHUENG	EDWARD	NASA GODDARD SPACE FLIGHT CENTER MAIL CODE 730 GREENBELT, MD 20771		91
CIRILLO	WILLIAM	NASA LANGLEY RESEARCH CENTER SSFO ADVANCED PROGRAMS OFFICE HAMPTON, VA 23665	(301) 670-7925	74
CLARK	FRED D.	LOCKHEED ENGINEERING & SCIENCES CO. 2400 NASA ROAD ONE/C87 HOUSTON, TX 77058	(713) 333-6284	15, 56
CLAUDINON	MR. BERNARD	MATRA-MARCONI SPACE 31, RUE DES COSMONAUTICS 31077 TOULOUSE, CEDEX, FRANCE (011) (33) 6139 6064		40

Automated Rendezvous & Capture Review

Abstract Authors

<u>LAST NAME</u>	<u>FIRST NAME</u>	<u>ADDRESS</u>	<u>PHONE/FAX NO.</u>	<u>ABSTRACT REF. NOS.</u>
COKER	CINDY	NASA MARSHALL SPACE FLIGHT CENTER EB24 HUNTSVILLE, AL 35812	(205) 544-3541	09
CONRAD	DAVID	SPACE AUTOMATION AND ROBOTICS CENTER P.O. BOX 134001 ANN ARBOR, MI 48113-4001	(313) 994-1200 (313) 668-8957	16
COTTERILL	STEPHEN	MAYFLOWER COMMUNICATIONS CO. 80 MAIN STREET READING, MA 01867		89
CUSEO	JOHN	MARTIN MARIETTA ASTRONAUTICS GROUP DENVER, CO 80201	(303) 971-9302	07, 17
DABNEY	RICHARD	NASA MARSHALL SPACE FLIGHT CENTER CODE ED13 HUNTSVILLE, AL 35812	(205) 544-1473 (205) 544-0236	18, 87
DAURO	VINCENT	NASA MARSHALL SPACE FLIGHT CENTER PD33 HUNTSVILLE, AL 35812	(205) 544-0546	19
DAVIS	JOHN E.	ROCKWELL INTERNATIONAL CORPORATION 3370 MIRALOMA AVE. P.O. BOX 4192 ANAHEIM, CA 92803-4192	(714) 762-2472 (714) 762-0766	22
DAWSON	TRAVIS	NASA MARSHALL SPACE FLIGHT CENTER PD12 HUNTSVILLE, AL 35812	(205) 544-9061	20
DEATON	A. WAYNE	NASA MARSHALL SPACE FLIGHT CENTER EL58 HUNTSVILLE, AL 35812	(205) 544-2247	58, 90
DEKOME	KENT	NASA JOHNSON SPACE CENTER/LESC 2400 NASA ROAD ONE/MCEE6 HOUSTON, TX 77058	(713) 483-1453 (713) 483-5830	21
DOBBS	MICHAEL E.	SPACE AUTOMATION AND ROBOTICS CENTER P.O. BOX 134001 ANN ARBOR, MI 48113-4001	(313) 994-1200 (313) 668-8957	16

Automated Rendezvous & Capture Review

Abstract Authors

<u>LAST NAME</u>	<u>FIRST NAME</u>	<u>ADDRESS</u>	<u>PHONE/FAX NO.</u>	<u>ABSTRACT REF. NOS.</u>
DONOVAN	WILLIAM J.	ROCKWELL INTERNATIONAL CORPORATION 3370 MIRALOMA AVE. FB70 ANAHEIM, CA 92803-4192	(714) 762-2472 (714) 762-0766	22, 71
DOUGHERTY	ANDREW	NASA GODDARD SPACE FLIGHT CENTER MC 441 GREENBELT, MD 20771	(301)0286-1334 (301) 286-2014	23
DOYLE	SUSAN C.	TRW ENGINEERING & TEST DIVISION ONE SPACE PARK, BLD R9/1869 REDONDO BEACH, CA 90278	(213) 814-6073 (213) 814-8068	29
DRAZNIN	MICHAEL	TRW FEDERAL SYSTEMS DIVISION 1 SPACE PARK, BLDG R11/2337 REDONDO BEACH, CA 90278	(213) 812-2608 (213) 812-8016	87
DUNKIN	JAMES A.	NASA MARSHALL SPACE FLIGHT CENTER EB23 HUNTSVILLE, AL 35812	(205) 544-3690 (205) 544-2659	24
EARLEY	SID M.	MARTIN MARIETTA CIVIL SPACE AND COMMUNICATIONS P.O. BOX 179 (M/S: DCS060) DENVER, CO 80201	(303) 971-6873 (303)977-1893	78
EICK	RICHARD E.	TRW 1110 NASA ROAD ONE HOUSTON, TX 77058	(713) 333-3133 (713) 333-1875	43, 56
ELLIS	STEPHEN	NASA AMES RESEARCH CENTER AERO-SPACE HUMAN FACTORS RESEARCH DIVISION MOFFETT FIELD, CA 94035		25
EMMET	BRIAN R.	GENERAL DYNAMICS, SPACE SYSTEMS P.O. BOX 85990 SAN DIEGO, CA 92816-5990		26
EVERETT	LOUIS J.	TEXAS A&M UNIVERSITY MECHANICAL ENGINEERING DEPT. COLLEGE STATION, TX 77843		27
FALKENHAYN	ED	NASA GODDARD SPACE FLIGHT CENTER CODE 408 GREENBELT, MD 20771	(301) 286-4144	28

Automated Rendezvous & Capture Review Abstract Authors

LAST NAME	FIRST NAME	ADDRESS	PHONE/FAX NO.	ABSTRACT REF. NOS.
FESQ	LORRAINE M.	TRW ENGINEERING & TEST DIVISION ONE SPACE PARK, BLD R9/1869 REDONDO BEACH, CA 90278	(213) 814-6073 (213) 814-8068	29
FISHER	TIMOTHY	NASA JOHNSON SPACE CENTER TRACKING AND COMMUNICATIN DIVISION HOUSTON, TX 77058	(713) 483-1456 (713) 483-5830	30
FLECKLIN	ANTON	ROCKWELL INTERNATIONAL SPACE SYSTEMS DIVISION/MC FC94 12214 LAKEWOOD BLVD DOWNEY, CA 92649		31
FREHLICH	DR. ROD	NASA MARSHALL SPACE FLIGHT CENTER EB23 HUNTSVILLE, AL 35812		24
FREY	RANDY	AUTONOMOUS TECHNOLOGIES CO. 520 N. SEMORAN, STE. 180 ORLANDO, FL	(407) 281-1262 (407) 282-9510	32
FUCHS	RON	LOCKHEED MISSILES AND SPACE COMPANY 2400 NASA ROAD ONE HOUSTON, TX 77058		61
GILBERT	JOHN A.	UNIVERSITY OF ALABAMA MECHANICAL ENGINEERING DEPT HUNTSVILLE, AL 35899		33
GLAESE	JOHN	LOGICON CONTROL DYNAMICS, CO. 600 BOULEVARD SOUTH, SUITE 304 HUNTSVILLE, AL 35802	(205) 882-2650 (205) 882-2683	94
GODDARD	RALPH	JET PROPULSION LABORATORY 4800 OAK GROVE DRIVE PASADENA, CA 91109	(818) 354-0145 393-4440	06
GOODE	PLEASANT W.	NASA LANGLEY RESEARCH CENTER INFORMATION SYSTEMS/FLIGHT SYSTEMS DIRECTORATE HAMPTON, VA 23665	(804) 864-8207	52
GRIMM	DR. GARY E.	TRW APPLIED TECHNOLOGY DIVISION 1 SPACE PARK, BLDG R1/2054 REDONDO BEACH, CA 90278	(213) 812-9639 (213) 812-0109	34

Automated Rendezvous & Capture Review Abstract Authors

<u>LAST NAME</u>	<u>FIRST NAME</u>	<u>ADDRESS</u>	<u>PHONE/FAX NO.</u>	<u>ABSTRACT REF. NOS.</u>
GRUNWALD	ARTHUR	NASA AMES RESEARCH CENTER M/S 262-3 MOFFETT FIELD, CA 94035	(415) 504-0104	25
HALE	JOSEPH	NASA MARSHALL SPACE FLIGHT CENTER CODE EO23 HUNTSVILLE, AL 35812		35
HALLSTROM	J.V.	ROCKWELL INTERNATIONAL 600 GEMINI R14E HOUSTON, TX 77058	(713) 282-4578 (713) 282-4095	43
HENDERSON	DAVID M.	TRW P.O. BOX 58327 HOUSTON, TX 77258	(713) 333-3133 (713) 333-1875	36, 37
HIERS	HAL	NASA JOHNSON SPACE CENTER EP2 HOUSTON, TX 77058	(713) 483-2036 (713) 483-3204	38, 43
HINMAN	ELAINE M.	NASA MARSHALL SPACE FLIGHT CENTER EB24 HUNTSVILLE, AL 35812	(205) 544-3519	39
HOFF	WILLIAM	MARTIN MARIETTA CIVIL SPACE AND COMMUNICATIONS MS 4372, P.O. BOX 179 DENVER, CO 80201	(303) 977-4739	81
HOHWIESNER	BILL	FAIRCHILD SPACE 20301 CENTURY BLVD GERMANTOWN, MD 20874	(301) 353-8924 (301) 353-1343	40
HOWARD	RICHARD	NASA MARSHALL SPACE FLIGHT CENTER EB24 HUNTSVILLE, AL 35812	(205) 544-3550 (205) 544-3801	34, 41
IDLE	CAPT. DUNNING	U.S. AIR FORCE PL/LIO KIRTLAND AFB, NEW MEXICO, 87117	505 846-4066	42
JACKSON	WILLIAM	NASA JOHNSON SPACE CENTER CODE EG 4 HOUSTON, TX 77058	(713) 483-8303 (713) 483-6134	43, 48

Automated Rendezvous & Capture Review Abstract Authors

<u>LAST NAME</u>	<u>FIRST NAME</u>	<u>ADDRESS</u>	<u>PHONE/FAX NO.</u>	<u>ABSTRACT REF. NOS.</u>
JENNINGS	JERRY	TRW FEDERAL SYSTEMS DIVISION 1 SPACE PARK, BLDG R111/1313 REDONDO BEACH, CA 90278	(213) 812-2627 (213) 812-8016	44, 45
JOHNSON	B.	NASA MARSHALL SPACE FLIGHT CENTER EB24 HUNTSVILLE, AL 35812	(205) 544-3518	09
JONES	ED	GENERAL DYNAMICS, SPACE SYSTEMS MZ 24-8710 P.O. BOX 85990 SAN DIEGO, CA 92816-5990		46
JUDAY	RICHARD	NASA JOHNSON SPACE CENTER TRACKING & COMMUNICATIONS DIVISION HOUSTON, TX 77058	(713) 483-1486 (713) 483-5830	47
KACHMAR	PETER M.	C.S. DRAPER LABORATORY MAIL STOP 2B 555 TECHNOLOGY SQUARE CAMBRIDGE, MA 02139-3563	(617) 258-1000 (617) 565-8674	48, 49, 50
KADER	JACK	UNITED TECHNOLOGIES-USBI P.O. BOX 1900 MS/4707 MSFC HUNTSVILLE, AL 35807	(205) 544-0869 (205) 544-3152	51
KATZBERG	STEPHEN J.	NASA LANGLEY RESEARCH CENTER INFORMATION SYSTEMS/FLIGHT SYSTEMS DIRECTORATE HAMPTON, VA 23665	(804) 864-8207	52
KENNEDY	LARRY Z.	APPLIED RESEARCH INC. 6700 ODYSSEY DRIVE HUNTSVILLE, AL 35906	(205) 922-8600	72
KESSLER	LYNN O.	MCDONNELL DOUGLAS SPACE SYSTEMS CO. 5301 BOLSA AVE. ADVANCED PRODUCTS DEV. & TECH. DIV. HUNTINGTON BEACH, CA 92649		88
KIM	K.J.	ROCKWELL INTERNATIONAL CORPORATION 3370 MIRALOMA AVE. P.O. BOX 4192 ANAHEIM, CA 92803-4192	(714) 762-2472 (714) 762-0766	71
KLUMPP	ALLAN	NASA JET PROPULSION LABORATORY 4800 OAK GROVE DRIVE PASADENA, CA 91109	(818) 354-6543	53

Automated Rendezvous & Capture Review

Abstract Authors

<u>LAST NAME</u>	<u>FIRST NAME</u>	<u>ADDRESS</u>	<u>PHONE/FAX NO.</u>	<u>ABSTRACT REF. NOS.</u>
KOCEN	MICHELLE	ROCKWELL SPACE OPERATIONS CO. 600 GEMINI HOUSTON, TX 77058	(713) 282-3271 (713) 282-4575	54
KUENZEL	FRED	GENERAL DYNAMICS, SPACE SYSTEMS P.O. BOX 85990 SAN DIEGO, CA 92816-5990		55
LAMKIN	STEVE	NASA JOHNSON SPACE CENTER EG HOUSTON, TX 77058	(713) 483-6284 (713) 483-6134	56
LE	T. QUAN	NASA JOHNSON SPACE CENTER EG4 HOUSTON, TX 77058	(713) 483-8304 (713) 483-6134	56, 78
LEE	ROSCOE	TRW SYSTEMS SERVICES CO. 1110 NASA ROAD ONE, SUITE 303 HOUSTON, TX 77258	(713) 333-3133 (713) 333-1875	43
LEND A	JOSEPH A.	MARTIN MARIETTA ASTRONAUTICS GROUP DENVER, CO 80201		07
LOCKE	JOHN W.	MOTOROLA CO., SED G1132 2501 S. PRICE RD CHANDLER, AZ 85248-2899	(602) 732-4057 (602) 732-2148	57
LOMAS	JAMES J.	NASA MARSHALL SPACE FLIGHT CENTER EL58 HUNTSVILLE, AL 35812	(205) 544-8305	58
LUM	DR. HENRY	NASA AMES RESEARCH CENTER MS 269-1 MOFFETT FIELD, CA 94035-1000	(415) 604-6544 (415) 604-6997	59
MAKI	STANLEY C.	GENERAL DYNAMICS, SPACE SYSTEMS P.O. BOX 85990 SAN DIEGO, CA 92816-5990	(619) 547-5364 (619) 974-4000	60
MALIN	MARK	LOCKHEED MISSILES AND SPACE CO. 3251 HANOVER STREET 66-01 PALO ALTO, CA 94304-1187	(415) 424-2111 (415) 354-5400	64

Automated Rendezvous & Capture Review Abstract Authors

<u>LAST NAME</u>	<u>FIRST NAME</u>	<u>ADDRESS</u>	<u>PHONE/FAX NO.</u>	<u>ABSTRACT REF. NOS.</u>
MARSH	STEVEN	LOCKHEED MISSILES AND SPACE COMPANY 2400 NASA ROAD ONE HOUSTON, TX 77058		61
MARTIN	ERIC	TRW ENGINEERING & TEST DIVISION ONE SPACE PARK, BLD R9/1869 REDONDO BEACH, CA 90278	(213) 814-6073 (213) 814-8068	29
MARZWELL	NEVILLE	NASA JET PROPULSION LABORATORY 4800 OAK GROVE DRIVE PASADENA, CA 91109	(818) 354-6543	62
MATUSKY	MARTIN	C.S. DRAPER LABORATORY MAIL STATION 2B 555 TECHNOLOGY SQUARE CAMBRIDGE, MA 02139	(617) 258-2440 (617) 565-8674	49
MCKINNIS	JIM A.	MARTIN MARIETTA P.O. BOX 179, MAIL STOP #55060 DENVER, CO 80201	(303) 977-9895 (303)977-1893	78
MCMANAMEN	JOHN P.	NASA JOHNSON SPACE CENTER ES6 HOUSTON, TX 77058	(713) 483-8958 (713) 483-6216	43
MERKEL	LAWRENCE	LOCKHEED ENGINEERING AND SCIENCES INTELLIGENT SYSTEMS DEPT., C19 2400 NASA ROAD ONE HOUSTON, TX 77058	(713) 333-6800	63
METHENY	WAYNE	LOCKHEED MISSILES AND SPACE CO. 3251 HANOVER STREET 97-30 PALO ALTO, CA 94304-1187	(415) 424-2111 (415) 354-5400	64
MONFORD	LEO	NASA JOHNSON SPACE CENTER IA141 HOUSTON, TX 77058	(713) 283-8249 (713) 283-5305	27, 65
MONTEZ	MOISES	NASA JOHNSON SPACE CENTER HOUSTON, TX 77058		50
MULDER	TOM	MCDONNELL DOUGLAS SPACE SYSTEMS CO 16055 SPACE CENTER BLVD HOUSTON, TX 77062-6208	(713) 283-4315 (713) 283-4020	66

Automated Rendezvous & Capture Review Abstract Authors

<u>LAST NAME</u>	<u>FIRST NAME</u>	<u>ADDRESS</u>	<u>PHONE/FAX NO.</u>	<u>ABSTRACT REF. NOS.</u>
NAUMANN	CHARLES	LOGICON CONTROL DYNAMICS CO. 600 BOULEVARD SOUTH, STE 304 HUNTSVILLE, AL 35802	(205) 882-2650 (205) 882-2683	86
NELSON	KURT	GENERAL DYNAMICS, SPACE SYSTEMS P.O. BOX 85990 SAN DIEGO, CA 92816-5990		67
NICHOLSON	BRUCE	GENERAL DYNAMICS, CONVAIR DIVISION P.O. BOX 85357 SAN DIEGO, CA 92816-5990		95
NOSEK	THOMAS	TRW FEDERAL SYSTEMS DIVISION 1 SPACE PARK, BLDG R11/2384 REDONDO BEACH, CA 90278	(213) 812-9028 (213) 812-0415	68
O'NEIL	DANIEL	NASA MARSHALL SPACE FLIGHT CENTER CODE PT31 HUNTSVILLE, AL 35812		35
OLDS	KEITH	MOTOROLA CO. STRATEGIC ELECTRONICS DIVISION 2501 S. PRICE RD CHANDLER, AZ 85248	(602) 732-3152 (602) 732-2148	57
OLSZWESKI	OSCAR	LOCKHEED ENGINEERING AND SCIENCES 2400 NASA ROAD ONE HOUSTON, TX 77058	(713) 333-6218 (713) 333-7201	38, 43
OTHON	L.T.	NASA JOHNSON SPACE CENTER ES HOUSTON, TX 77058	(713) 483-6396 (713) 483-5196	56
PARKS	HOWARD	MOTOROLA CO. STRATEGIC ELECTRONICS DIVISION 2501 S. PRICE RD CHANDLER, AZ 85248	(602) 732-4057 (602) 732-2148	57
PATRICK	STEVE	UNITED TECHNOLOGIES-USBI P.O. BOX 1900 HUNTSVILLE, AL 35807	(205) 721-5573	51
PIERCE	COLE	MCDONNELL DOUGLAS SPACE SYSTEMS 16055 SPACE CENTER BLVD HOUSTON, TX 77062	713 283-4087 713 283-4020	69

Automated Rendezvous & Capture Review Abstract Authors

<u>LAST NAME</u>	<u>FIRST NAME</u>	<u>ADDRESS</u>	<u>PHONE/FAX NO.</u>	<u>ABSTRACT REF. NOS.</u>
POLUTCHKO	ROBERT J.	C.S. DRAPER LABORATORY MAIL STATION 2B 555 TECHNOLOGY SQUARE CAMBRIDGE, MA 02139	(617) 258-1000 (617) 565-8674	49, 50
PRATHER	J.L.	NASA JOHNSON SPACE CENTER EE HOUSTON, TX 77058	(713) 483-1483 (713) 483-5830	43
PRATHER	J.L.	NASA JOHNSON SPACE CENTER EE HOUSTON, TX 77058	(713) 483-1483 (713) 483-5830	56
PRUST	ELLEN	MCDONNELL DOUGLAS SPACE SYSTEMS CO. 160555 SPACE CENTER BLVD HOUSTON, TX 77062	(713) 283-4277 (713) 283-4020	70
QUAID	THOMAS	MOTOROLA CO., G.E.G. 2501 S. PRICE RD, M/D G-1229 CHANDLER, AZ 85248	(602) 732-3014	57
RACE	L.	ROCKWELL INTERNATIONAL CORPORATION 3370 MIRALOMA AVE. P.O. BOX 4192 ANAHEIM, CA 92803-4192	(714) 762-2472 (714) 762-0766	71
RAY	LEX	MARTIN MARIETTA ASTRONAUTICS GROUP DENVER, CO 80201		07
RODGERS	MIKE	APPLIED RESEARCH INC. 6700 ODYSSEY DRIVE HUNTSVILLE, AL 35806	(205) 922-8600	72
ROE	FRED	NASA MARSHALL SPACE FLIGHT CENTER EB24 HUNTSVILLE, AL 35812	(205) 544-3512	09
ROURKE	KENNETH	TRW FEDERAL SYSTEMS DIVISION 1 SPACE PARK, BLDG R11/2337 REDONDO BEACH, CA 90278	(213) 812-2628 (213) 812-8016	73
RUE	D.L.	TRW P.O. BOX 58327 HOUSTON, TX 77258	(713) 333-3133 (713) 333-1875	43

Automated Rendezvous & Capture Review Abstract Authors

<u>LAST NAME</u>	<u>FIRST NAME</u>	<u>ADDRESS</u>	<u>PHONE/FAX NO.</u>	<u>ABSTRACT REF. NOS.</u>
SAUCILLO	RUDY	MDSSC, WASHINGTON SE&I 2092 GAITHER ROAD ROCKVILLE, MD 20850	(301) 670-7925	74
SAUGEN	JOHN D.	GENERAL DYNAMICS, SPACE SYSTEMS P.O. BOX 85990 SAN DIEGO, CA 92816-5990		76
SAUNDERS	PENNY	NASA JOHNSON SPACE CENTER TRACKING & COMMUNICATIONS DIVISION HOUSTON, TX 77058	(713) 483-1485 (713) 483-5830	75
SCHAKELFORD	JOHN H.	GENERAL DYNAMICS, SPACE SYSTEMS P.O. BOX 85990 SAN DIEGO, CA 92816-5990		76
SCHMITZ	ERIC	MARTIN MARIETTA CIVIL SPACE AND COMMUNICATIONS MS-4372, P.O. BOX 179 DENVER, CO 80201	(303) 971-4739	81
SCHOKNECHT	W.	ROCKWELL INTERNATIONAL CORPORATION 3370 MIRALOMA AVE. P.O. BOX 4192 ANAHEIM, CA 92803-4192	(714) 762-2472 (714) 762-0766	71
SELLERS	SUZANNE	TRW ENGINEERING & TEST DIVISION ONE SPACE PARK, BLD R9/1869 REDONDO BEACH, CA 90278	(213) 814-6073 (213) 814-8068	29
SIRKO	ROBERT J.	MCDONNELL DOUGLAS SPACE SYSTEMS CO. 5301 BOLSA AVE. ADVANCED PRODUCTS DEV. & TECH. DIV. HUNTINGTON BEACH, CA 92649		88
SJOLANDER	GARY W.	MARTIN MARIETTA ASTRONAUTICS GROUP DENVER, CO 80201	(303) 971-3257 (303) 977-1921	77
SKULSKY	E. DAVID	MICROCOSM, INC. 2601 AIRPORT DRIVE SUITE 230 TORRANCE, CA 90505	(213) 539-9444 (213) 539-7268	93
SMITH	NICK	MARTIN MARIETTA P.O. BOX 179, MS DC8082 DENVER, CO 80201	(303) 971-6873 (303)977-1893	78

Automated Rendezvous & Capture Review

Abstract Authors

<u>LAST NAME</u>	<u>FIRST NAME</u>	<u>ADDRESS</u>	<u>PHONE/FAX NO.</u>	<u>ABSTRACT REF. NOS.</u>
SMITH	ALAN	LOCKHEED ENGINEERING & SCIENCES CO. 2400 NASA ROAD ONE HOUSTON, TX 77058	(713) 483-1497	30
SPEHAR	PETER T.	LOCKHEED ENGINEERING & SCIENCES CO. 2400 NASA ROAD ONE HOUSTON, TX 77058	(713) 333-6540 (713) 333-6908	56,79
SPITZER	CHRISTOPHER	TRW FEDERAL SYSTEMS DIVISION 1 SPACE PARK, BLDG R11/2337 REDONDO BEACH, CA 90278	(213) 812-2598 (213) 812-8016	80
SPOFFORD	JOHN	MARTIN MARIETTA CIVIL SPACE AND COMMUNICATIONS MS-4372, P.O. BOX 179 DENVER, CO 80201	(303) 971-9319	81
STAAS	STEVEN K.	MCDONNELL DOUGLAS SPACE SYSTEMS CO. 16055 SPACE CENTER BLVD HOUSTON, TX 77062	(713) 283-4264 (713) 283-4020	82
STEPHAN	AMY.	TRW ENGINEERING & TEST DIVISION ONE SPACE PARK, BLD R9/1868 REDONDO BEACH, CA 90278	(213) 814-6073 (213) 814-8068	29
SUTTON	WILLIAM	NASA MARSHALL SPACE FLIGHT CENTER CODE EB44 HUNTSVILLE, AL 35812	(205) 544-3824	83
SZATKOWSKI	GERARD P.	GENERAL DYNAMICS, SPACE SYSTEMS P.O. BOX 85990 SAN DIEGO, CA 92138-5990		84
TCHORYK	PETER	SPACE AUTOMATION AND ROBOTICS CENTER P.O. BOX 134001 ANN ARBOR, MI 48113-4001	(313) 994-1200 (313) 668-8957	16
TEDERS	R.J.	LOCKHEED ENGINEERING AND SCIENCES CO 2400 NASA ROAD ONE/B14 HOUSTON, TX 77058	(713) 333-6380 (713) 333-8038	56
THOMPSON	ALLEN B.	MARTIN MARIETTA CIVIL SPACE AND COMMUNICATIONS DENVER, CO 80201	(303) 977-6037 (303) 977-1893	85

Automated Rendezvous & Capture Review

Abstract Authors

<u>LAST NAME</u>	<u>FIRST NAME</u>	<u>ADDRESS</u>	<u>PHONE/FAX NO.</u>	<u>ABSTRACT REF. NOS.</u>
THOMPSON	JOHN A.	LOCKHEED ENGINEERING & SCIENCES CO. 2400 NASA ROAD ONE HOUSTON, TX 77058	(713) 483-7746	12
TOBBE	PATRICK	LOGICON CONTROL DYNAMICS, CO. 600 BOULEVARD SOUTH, SUITE 304 HUNTSVILLE, AL 35802	(205) 882-2650 (205) 882-2683	83, 86, 94
TOOLE	JENNIFER R.	LOCKHEED ENGINEERING & SCIENCES CO. 2400 NASA ROAD 1 HOUSTON, TX 77058	(713) 333-7259 (713) 333-6626	92
TSUGAWA	ROY K.	TRW FEDERAL SYSTEMS DIVISION 1 SPACE PARK, BLDG R11/2337 REDONDO BEACH, CA 90278	(213) 812-2608 (213) 812-8016	01, 73, 87
TUBBS	DAVID J.	MCDONNELL DOUGLAS SPACE SYSTEMS CO. 5301 BOLSA AVE. ADVANCED PRODUCTS DEV. & TECH. DIV. HUNTINGTON BEACH, CA 92649		88
UDOMKESMALEE	SURAPHOL	JET PROPULSION LABORATORY CALIFORNIA INSTITUTE OF TECHNOLOGY 4800 OAK GROVE DRIVE PASADENA, CA 91109	(818) 354-0614	89
UPADHYAY	TRIVENI M.	MAYFLOWER COMMUNICATIONS CO. 80 MAIN STREET READING, MA 01867		90
VIKRAM	CHANDRA S.	UNITED TECHNOLOGIES-USBI P.O. BOX 1900 HUNTSVILLE, AL 35807	(205) 895-6102	51
VRAINISH	JOHN	NASA GODDARD SPACE FLIGHT CENTER MAIL CODE 730 GREENBELT, MD 20771		91
WALKER	JAMES	TRW FEDERAL SYSTEMS DIVISION 1 SPACE PARK, BLDG R11/1313 REDONDO BEACH, CA 90278	(213) 812-0852 (213) 812-7296	45
WANG	J.	ROCKWELL INTERNATIONAL CORPORATION 3370 MIRALOMA AVE. P.O. BOX 4192 ANAHEIM, CA 92803-4192	(714) 762-2472 (714) 762-0766	71

Automated Rendezvous & Capture Review

Abstract Authors

<u>LAST NAME</u>	<u>FIRST NAME</u>	<u>ADDRESS</u>	<u>PHONE/FAX NO.</u>	<u>ABSTRACT REF. NOS.</u>
WERTZ	JAMES R.	MICROCOSM, INC. 2601 AIRPORT DRIVE SUITE 230 TORRANCE, CA 90505	(213) 539-9444 (213) 539-7268	92
WHEELWRIGHT	CHARLES	LOCKHEED ENGINEERING & SCIENCES CO. MAN SYSTEMS/HUMAN FACTORS ENG. DEPT 2400 NASA ROAD ONE HOUSTON, TX 77058	(713) 333-7815 (713) 333-6626	93
WHITSETT	EDWARD	NASA JOHNSON SPACE CENTER MAIL CODE ER1 HOUSTON, TX 77058	(713) 483-9111	07
WHITTEN	RAYMOND P.	NASA HEADQUARTERS CODE CC WASHINGTON, D.C. 20546		16
WILLIAMS	PHILIP	LOGICON CONTROL DYNAMICS, CO. 600 BOULEVARD SOUTH, SUITE 304 HUNTSVILLE, AL 35802	(205) 882-2720 EXT 148 (205) 882-2683	94
WOOKEY	CATHY	GENERAL DYNAMICS, CONVAIR DIVISION P.O. BOX 85357 SAN DIEGO, CA 92816-5990		95
WURST	MICHAEL J.	GENERAL DYNAMICS, SPACE SYSTEMS P.O. BOX 85990 SAN DIEGO, CA 92816-5990		76
ZIMMER	K.J.	NASA JOHNSON SPACE CENTER ER3 HOUSTON, TX 77058	(713) 483-1718 (713) 483-3204	43