

OPPORTUNITIES FOR RESEARCH ON SPACE STATION FREEDOM

Presented by Dr. Robert Phillips
NASA Office of Space Systems Development
NASA Headquarters

ABSTRACT

NASA has allocated research accommodations on Freedom (equipment, utilities, etc.) to the program offices that sponsor space-based research and development as follows: Space Science and Applications (OSSA) — 52 percent, Commercial Programs (OCP) — 28 percent, Aeronautics and Space Technology (OAST) — 12 percent, and Space Flight (OSF) — 8 percent.

Most of OSSA's allocation will be used for microgravity and life science experiments; although OSSA's space physics, astrophysics, earth science and applications, and solar system exploration divisions also will use some of this allocation.

Other Federal agencies have expressed an interest in using Space Station Freedom. They include the National Institutes of Health (NIH), U.S. Geological Survey, National Science Foundation, National Oceanic and Atmospheric Administration, and U.S. Departments of Agriculture and Energy.

Payload interfaces with space station lab support equipment must be simple, and experiment packages must be highly contained. Freedom's research facilities will feature International Standard Payload Racks (ISPRs), experiment racks that are about twice the size of a Spacelab rack. ESA's Columbus lab will feature 20 racks, the U.S. lab will have 12 racks, and the Japanese lab will have 10. Thus, Freedom will have a total of 42 racks versus 8 for Spacelab.

NASA is considering outfitting some rack space to accommodate small, self-contained payloads similar to the Get-Away-Special canisters and middeck-locker experiment packages flown on Space Shuttle missions. Crew time allotted to experiments on Freedom at permanently occupied capability will average 25 minutes per rack per day, compared to six hours per rack per day on Spacelab missions. Hence, telescience — the remote operation of space-based experiments by researchers on the ground — will play a very important role in space station research.

Plans for supporting life sciences research on Freedom focus on the two basic goals of NASA's space life sciences program: to ensure the health, safety, and productivity of humans in space and to acquire fundamental knowledge of biological processes.

Space-based research has already shown that people and plants respond the same way to the microgravity environment: they lose structure. However, the mechanisms by which they respond are different, and researchers do not yet know much about these mechanisms. Life science research accommodations on Freedom will include facilities for experiments designed to address this and other questions, in fields such as gravitational biology, space physiology, and biomedical monitoring and countermeasures research.

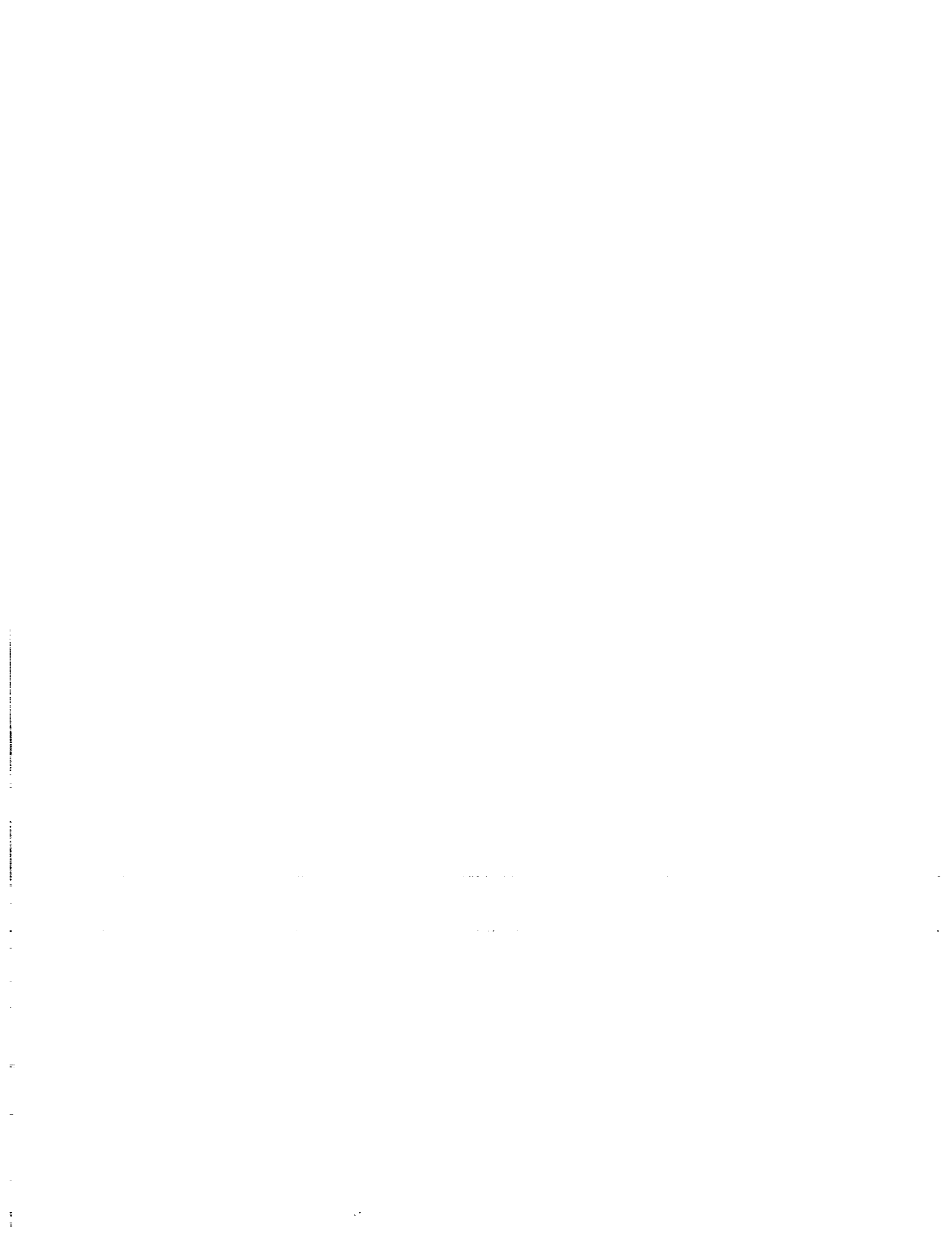

OPPORTUNITIES FOR RESEARCH ON SPACE STATION FREEDOM

**ROBERT W. PHILLIPS
CHIEF SCIENTIST
SPACE STATION FREEDOM**

SPACE STATION FREEDOM WILL BE:

- **A WORLD CLASS MICROGRAVITY LABORATORY**
- **AN INTERNATIONAL FACILITY DESIGNED TO
ADVANCE SCIENCE AND TECHNOLOGY IN
THE SPACE ENVIRONMENT**
- **A TEST BED FOR DEVELOPING THE EXPERIENCE
AND TECHNOLOGIES TO EXPLORE THE MOON
AND MARS**

USER ORGANIZATION SUBALLOCATIONS

<u>ORGANIZATION</u>	<u>SUBALLOCATION OF RESOURCES</u>
OFFICE OF SPACE SCIENCE AND APPLICATIONS (OSSA)	52%
OFFICE OF COMMERCIAL PROGRAMS (OCP)	28%
OFFICE OF AERONAUTICS AND SPACE TECHNOLOGY (OAST)	12%
OFFICE OF SPACE FLIGHT (OSF)	8%

OFFICE OF SPACE SCIENCE AND APPLICATIONS

- **DIVISION OF LIFE SCIENCES**
- **DIVISION OF MICROGRAVITY SCIENCES**
- **DIVISION OF EARTH SCIENCE AND APPLICATIONS**
- **DIVISION OF SPACE PHYSICS**
- **DIVISION OF ASTROPHYSICS**
- **DIVISION OF SOLAR SYSTEM EXPLORATION**

NATIONAL INSTITUTE OF HEALTH (NIH)

NATIONAL SCIENCE FOUNDATION (NSF)

**NATIONAL OCEANIC & ATMOSPHERIC
ADMINISTRATION (NOAA)**

DEPARTMENT OF AGRICULTURE (DA)

**NATIONAL TELECOMMUNICATIONS AND
INFORMATION ADMINISTRATION (NTIA)**

DEPARTMENT OF ENERGY (DOE)

UNITED STATES GEOLOGICAL SURVEY (USGS)

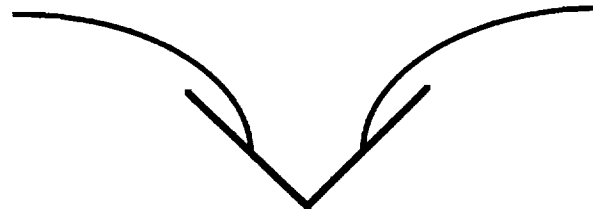

OSSA

**SSF WILL HOUSE
DEDICATED CORE
RESEARCH FACILITIES
IN THE PRESSURIZED
VOLUME**

- **USER-PROVIDED CORE FACILITIES CAN BE SUPPLEMENTED BY EXPERIMENT-UNIQUE EQUIPMENT AND GENERAL LABORATORY SUPPORT EQUIPMENT.**
- **SSF WILL PROVIDE THE BASIC UTILITIES NEEDED TO SUPPORT EXPERIMENT OPERATION (DATA MANAGEMENT, POWER, COOLING, ETC.).**

Space Station Freedom Module Cluster

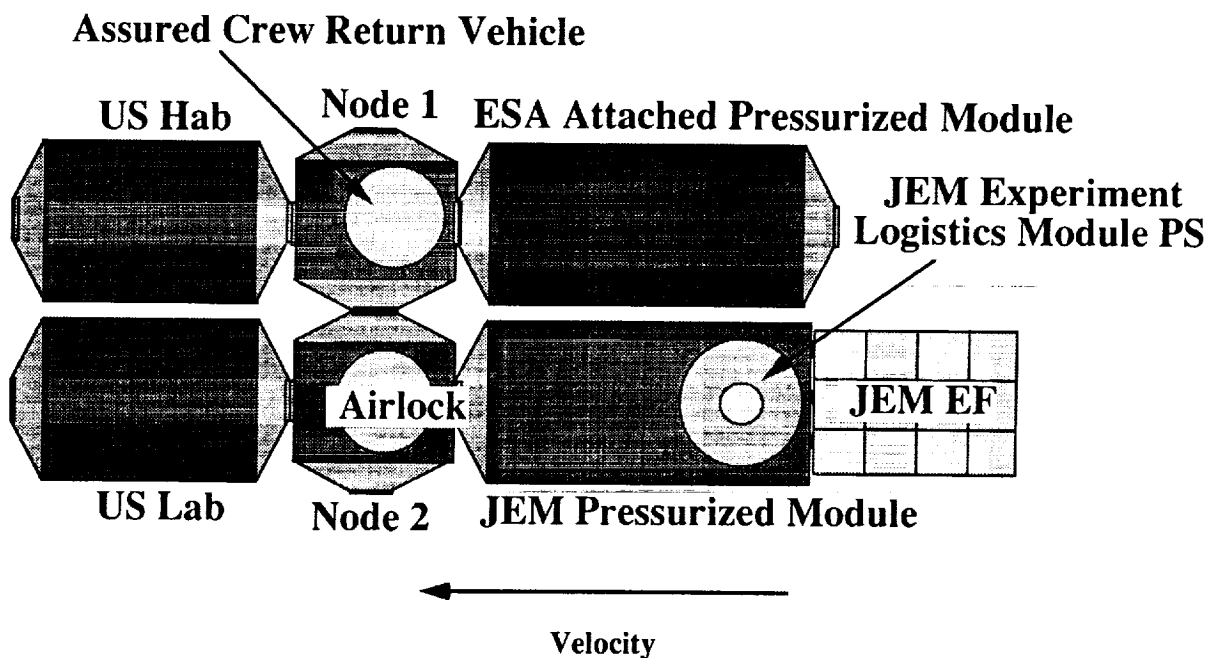

Spacelab/Space Station Resource Comparison

Resource	SSFP @ PMC	Spacelab
Payload racks	44	8
Payload Power (kW)	30	3.4
Power per Rack (kW)	.68	.42
Crew	2+	4+

Crew Time Available for Payload Operations

- The large payload complement on Space Station Freedom will make crew time a valuable resource.
- Crew hours per payload rack comparison with Spacelab:
 - Spacelab typically offers about 6 hours per (double) rack per day;
 - At PMC, Space Station will offer about 25 minutes per rack per day.

(One Space Station rack is equivalent to a Spacelab double rack)

- Reduced crew time available for each rack mandates an increase in the use of automation and/or telepresence in payload design.

DEDICATED SMALL PAYLOAD ACCOMMODATIONS RACK CONCEPT

Existing Container Hardware:

Integrated Small Payload System

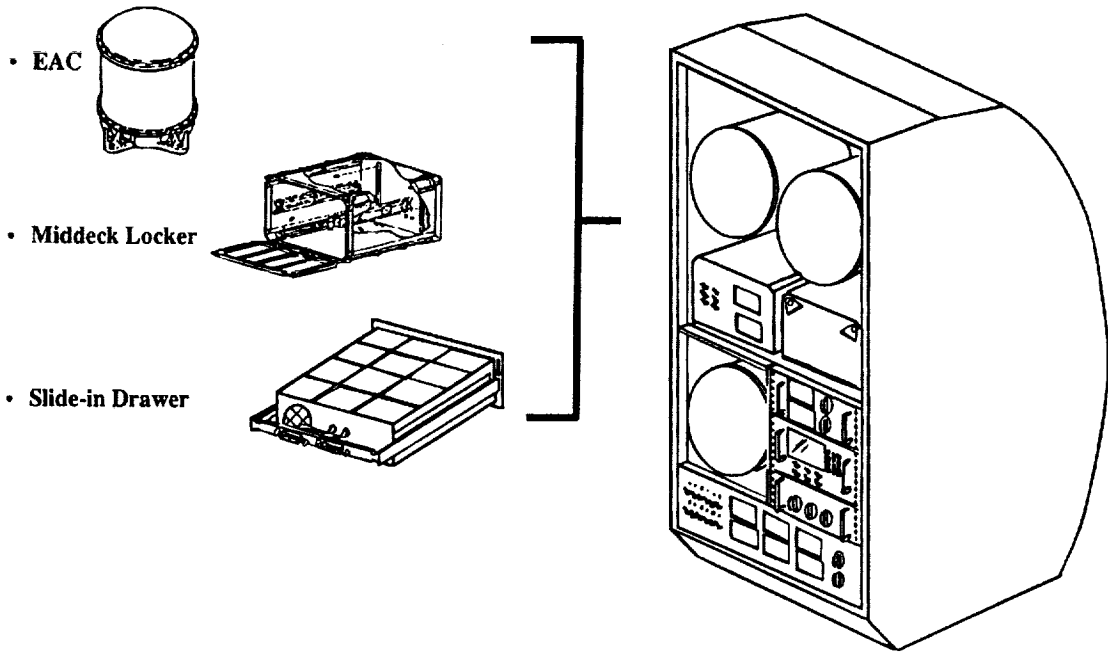

LIFE SCIENCES

MICROGRAVITY SCIENCES

ATTACHED PAYLOADS

LIFE SCIENCES ON SPACE STATION FREEDOM

**WILL PROVIDE THE OPPORTUNITY
TO STUDY MULTIGENERATIONAL
EFFECTS OF SPACE EXPOSURE ON
PLANTS AND ANIMALS**

MICROGRAVITY SCIENCE FACILITIES

- **ADVANCED PROTEIN CRYSTAL GROWTH**
- **SPACE STATION FURNACE**
- **COMBUSTION**
- **FLUID PHYSICS DYNAMICS**
- **CONTAINERLESS PROCESSING**
- **BIOTECHNOLOGY**

ATTACHED PAYLOADS WILL PROVIDE THE OPPORTUNITY:

- TO STUDY THE SPACE ENVIRONMENT
- TO OBSERVE THE EARTH'S TROPICAL REGIONS
- TO OBSERVE OUTWARD

Japanese Experiment Module - Exposed Facility (JEM - EF)

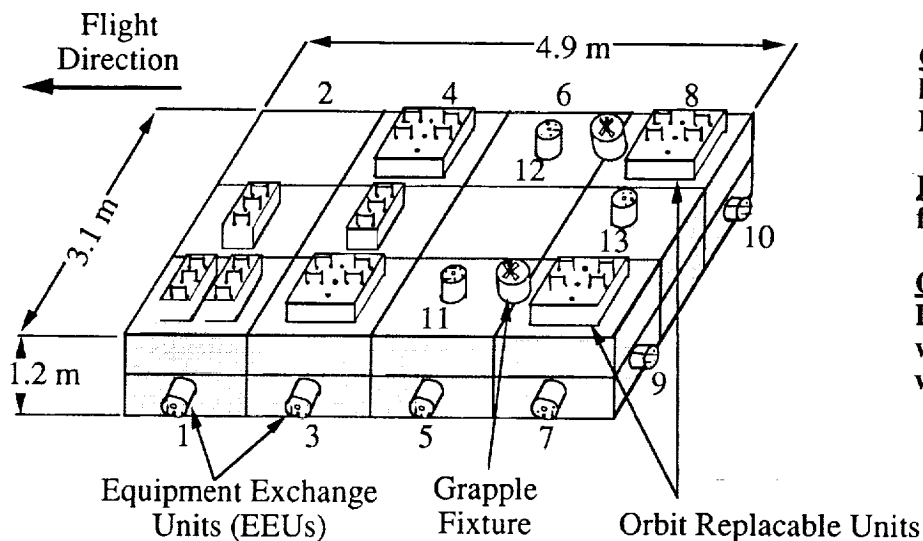

Grapple Fixture - allows handling of JEM - EF by RMS

EEU - Attachment point for JEM - EF payloads

ORUs - equipment such as DC to DC Converter Units which can be replaced while on-orbit

**SPACE STATION FREEDOM
REPRESENTS THE FIRST
OPPORTUNITY TO DEVELOP
A PROGRAM TO UNDERSTAND
AND EXPLAIN MICROGRAVITY
EFFECTS AND THE SPACE
ENVIRONMENT.**

**IT IS, HOWEVER, A BEGINNING,
NOT AN END.**

**WE URGE YOU TO JOIN IN THIS
ADVENTURE!**

