

(NASA-TM-107556) DEBRIS/ICE/TPS
ASSESSMENT AND INTEGRATED
PHOTOGRAPHIC ANALYSIS OF SHUTTLE
MISSION STS-53 (NASA) 141 p

N93-23085

Unclas

G3/16 0150343

495312 rrp

Debris/Ice/TPS Assessment And Integrated Photographic Analysis For Shuttle Mission STS-53

January 1993



National Aeronautics and
Space Administration

ORIGINAL CONTAINS
COLOR ILLUSTRATIONS

Debris/Ice/TPS Assessment And Integrated Photographic Analysis For Shuttle Mission STS-53

Gregory N. Katnik
NASA/Kennedy Space Center

Scott A. Higginbotham
NASA/Kennedy Space Center

J. Bradley Davis
NASA/Kennedy Space Center

ORIGINAL CONTAINS
COLOR ILLUSTRATIONS

January 1993



DEBRIS/ICE/TPS ASSESSMENT
AND
PHOTOGRAPHIC ANALYSIS
OF
SHUTTLE MISSION STS-53

December 2, 1992

Prepared By:

Scott A. Higginbotham
Scott A. Higginbotham
NASA/Kennedy Space Center
TV-MSD-22

J. Bradley Davis
J. Bradley Davis
NASA/Kennedy Space Center
TV-MSD-22

Approved:

Gregory N. Katnik
Gregory N. Katnik
Lead, Ice/Debris/Photo Analysis
NASA/Kennedy Space Center
TV-MSD-22

Pedro J. Rosado
Pedro J. Rosado
Chief, ET Mechanical Sys
NASA/Kennedy Space Center
TV-MSD-22

TABLE OF CONTENTS

1.0	Summary	2
2.0	Pre-Launch Briefing	5
2.1	Pre-Launch SSV/Pad Debris Inspection . .	6
3.0	Launch	10
3.1	Ice/Frost Inspection	10
3.2	Orbiter	10
3.3	Solid Rocket Boosters	10
3.4	External Tank	13
3.5	Facility	17
4.0	Post Launch Pad Debris Inspection . . .	29
5.0	KSC Film Review and Problem Reports . .	33
5.1	Launch Film and Video Summary	33
5.2	On-Orbit Film and Video Summary	41
5.3	Landing Film and Video Summary	44
6.0	SRB Post Flight/Retrieval Assessment . .	45
6.1	RH SRB Debris Inspection	45
6.2	LH SRB Debris Inspection	53
6.3	Recovered SRB Disassembly Findings . . .	61
7.0	Orbiter Post Landing Debris Assessment .	63
8.0	Debris Sample Lab Reports	84
9.0	Post Launch Anomalies	92
9.1	Launch Pad/Facility	92
9.2	External Tank	92
9.3	Solid Rocket Boosters	92
9.4	Orbiter	92
	Appendix A. JSC Photographic Analysis Summary .	93
	Appendix B. MSFC Photographic Analysis Summary.	118
	Appendix C. Rockwell Photo Analysis Summary . .	130

FOREWORD

The Debris Team has developed and implemented measures to control damage from debris in the Shuttle operational environment and to make the control measures a part of routine launch flows. These measures include engineering surveillance during vehicle processing and closeout operations, facility and flight hardware inspections before and after launch, and photographic analysis of mission events.

Photographic analyses of mission imagery from launch, on-orbit, and landing provide significant data in verifying proper operation of systems and evaluating anomalies. In addition to the Kennedy Space Center (KSC) Photo/Video Analysis, reports from Johnson Space Center, Marshall Space Flight Center, and Rockwell International - Downey are also included in this document to provide an integrated assessment of the mission.

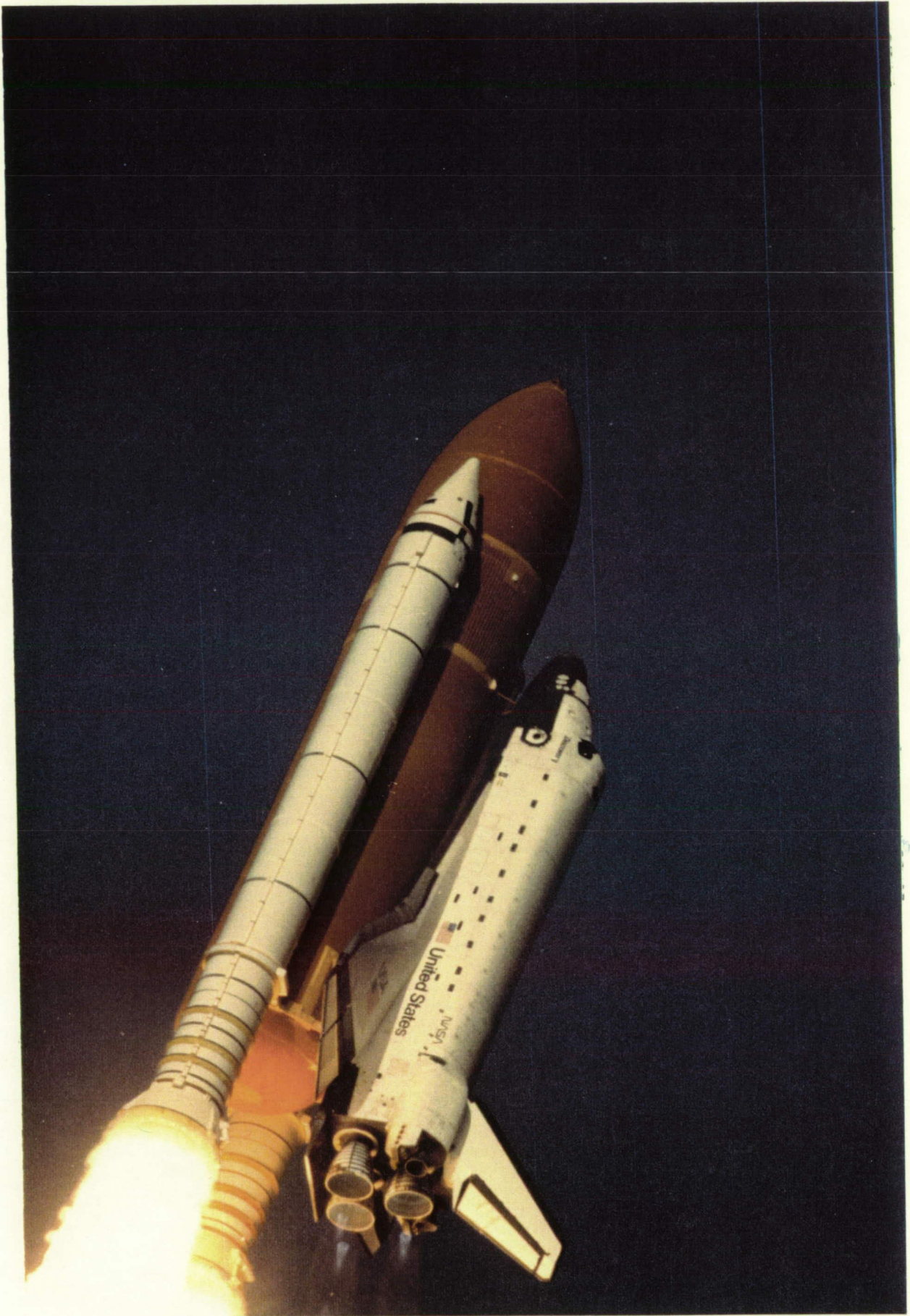

Shuttle Mission STS-53 was launched at 8:24 a.m. local 12/2/92

1.0 Summary

The pre-launch debris inspection of the pad and Shuttle vehicle was conducted on 1 December 1992. The detailed walkdown of Launch Pad 39A and MLP-1 also included the primary flight elements OV-103 Discovery (15th flight), ET-49 (LWT 42), and BI-055 SRB's. There were no vehicle or facility anomalies.

The vehicle was cryoloaded for flight on 2 December 1992. There were no Launch Commit Criteria, OMRS, or NSTS-08303 violations with the exception of acreage ice/frost exceeding 0.0625 inches. Delaying the launch approximately 90 minutes after sunrise allowed melting of the acreage ice/frost. A second ice inspection at T-9 minutes confirmed there was no LCC violations and lifted the constraint to launch. The LH2 ET/ORB umbilical leak sensor detected no significant hydrogen leakage during the cryoload. No unusual vapors or cryogenic drips were visible during tanking, stable replenish, and launch. A crack that extended 2/3 the width of the -Y vertical strut cable tray was present in the forward surface TPS near the longeron closeout interface. Although jagged in appearance, the crack exhibited no offset and was not filled with ice or frost. The appearance of the crack was expected due to the elimination of the stress relief gap at the factory. The condition was acceptable for launch per NSTS-08303 and CR S041254C.

A debris inspection of Pad 39A was performed after launch. No flight hardware was found with the exception of one FRSI plug. EPON shim material on the south holddown posts was intact but slightly debonded. There was no visual indication of a stud hang-up on any of the south holddown posts. No frangible nut/ordnance fragments were found. The GH2 vent line had latched properly. Damage to the facility overall was minimal.

A total of 123 film and video items were analyzed as part of the post launch data review. No major vehicle damage or lost flight hardware was observed that would have affected the mission. Numerous camera views showed that ice accumulation on the Orbiter side of the External Tank had melted prior to the time of lift off. Ice/frost covered a substantial part of the ET -Z side LH2 tank, but was not a concern for launch. Orange vapor (burning hydrogen) was visible between the exit plane and the #9 hatband near the steer horn, or the coolant manifold, on the SSME #2 nozzle -Z side. This event is similar to the cold wall hydrogen leak observed during SSME #2 ignition for STS-44. A stud hang-up occurred on HDP #1. The stud remained fully extended until clear of the aft skirt foot, twanged briefly, and then dropped into the holddown post. On-orbit photography revealed ET structural separation from the Orbiter appeared nominal. The BSM burn scars on the LO2 tank were typical. No anomalies were observed on the nosecone, LO2 tank acreage, PAL ramps, and LH2 tank.

Six divots were visible in the aft dome spray abort. Four divots occurred in the LH2 tank-to-intertank flange closeout. Residual hydrogen was venting from the LH2 ET/ORB umbilical - a phenomenon that has been observed on previous tanks. Film analysis also showed orbiter performance, landing gear extension, wheel touchdown, and vehicle rollout after landing were normal.

The Solid Rocket Boosters were inspected at Hanger AF after retrieval. The RH frustum had 16 MSA-2 debonds and one 1-inch diameter area of missing TPS between the +Y and -Z axes at the 381 ring frame. The LH frustum had 28 MSA-2 debonds over fasteners. Torn and missing MSA-2 (1-inch diameter) from one location between the +Y and +Z axes just aft of the 336 ring frame may have been the result of handling damage. Three pins were missing from the LH frustum severance ring, a condition that reportedly was the result of parachute entanglement. All Debris Containment System (DCS) plungers were seated properly. The HDP #1 stud hole was broached due to a stud hang-up. A 10"x3" area of EPON shim was missing from HDP #3. The material was lost prior to water impact (sooted/charred substrate).

A 2.75 inch long (mild radius) by 0.125 inch wide fracture was discovered in the RH SRB aft skirt center BSM mounting base cover TPS. The fracture/incision occurred at an angle of approximately 30 degrees to the SRB centerline and extended through the 0.5 inch thick cork closeout to the substrate. Soot deposits, erosion, heat effects, and discoloration were visible around the damage site. Twelve black and white particles, or flakes, were subsequently discovered inside the fracture/incision. Laboratory analysis determined the particles and flakes were high in silica content and are believed to be pieces of Orbiter lower surface tile. The analysis concluded the aft skirt cork damage was most likely caused by an impact from ascent debris containing Orbiter tile material.

A detailed post landing inspection of OV-103 was conducted on 9 December 1992. The Orbiter TPS sustained a total of 240 hits, of which 23 had a major dimension of one inch or greater. The Orbiter lower surface had a total of 145 hits, of which 11 had a major dimension of one inch or greater. Based on these numbers and comparison to statistics from previous missions of similar configuration, the total number of Orbiter TPS debris hits was greater than average and the number of hits one inch or larger was average. All three ET/Orbiter separation devices (EO-1, 2, and 3) and all ET/ORB umbilical separation ordnance retention shutters functioned properly. No flight hardware was found on the runway below the umbilicals when the ET doors were opened.

This flight marked the fifth use of the Orbiter drag chute. The drag chute appeared to have functioned nominally. All drag chute hardware was recovered and showed no signs of abnormal operation.

A variety of residuals were present in the Orbiter window samples and indicated sources such as Orbiter TPS, SRB BSM exhaust residue, natural landing site products, organics, paint, and "solder-type" residue (ground processing). The L02 umbilical door sample revealed only closeout residues and an unidentified "grease-like" residue. The sample from the SRB aft skirt TPS damage site exhibited indications of tile materials and an assortment of common elemental residues. This residual sampling data did not point to a single source of damaging debris as all of the materials have been documented previously in post-landing sample reports. The residual sample data also gave no indication of debris trends when compared to previous mission data.

A total of 8 Post Launch Anomalies, but no IFA candidates, were observed during the STS-53 mission assessment.

2.0 PRE-LAUNCH BRIEFING

The Ice/Debris/TPS/Photographic Analysis Team briefing for launch activities was conducted on 1 December 1992 at 0800 hours with the following key personnel present:

S. Higginbotham	NASA - KSC	STI, Ice/Debris Assessment
B. Davis	NASA - KSC	STI, Ice/Debris Assessment
G. Katnik	NASA - KSC	Lead, Ice/Debris/Photo Team
B. Speece	NASA - KSC	Lead, ET Thermal Protection
B. Bowen	NASA - KSC	ET Processing, Ice/Debris
K. Tenbusch	NASA - KSC	ET Processing, Ice/Debris
P. Rosado	NASA - KSC	Chief, ET Mechanical Systems
J. Rivera	NASA - KSC	Lead, ET Structures
A. Oliu	NASA - KSC	ET Processing, Ice/Debris
J. Cawby	LSOC - SPC	Supervisor, ET Processing
R. Seale	LSOC - SPC	ET Processing
M. Jaime	LSOC - SPC	ET Processing
M. Dean	LSOC - SPC	ET Processing
W. Richards	LSOC - SPC	ET Processing
Z. Byrns	NASA - JSC	Level II Integration
S. Copsey	MMC - MAF	ET TPS Testing/Certif
J. McClymonds	RI - DNY	Debris Assess, LVL II Integ
K. Mayer	RI - LSS	Vehicle Integration
J. Cook	MTI - LSS	SRM Processing
C. Cooper	MTI - LSS	SRM Processing
S. Otto	MMC - LSS	ET Processing

These personnel participated in various team activities, assisted in the collection and evaluation of data, and contributed to reports contained in this document.

2.1 PRE-LAUNCH SSV/PAD DEBRIS INSPECTION

A pre-launch debris inspection of the pad and Shuttle vehicle was conducted on 1 December 1992 from 0830 - 0930 hours. The detailed walkdown of Launch Pad 39A and MLP-1 also included the primary flight elements OV-103 Discovery (15th flight), ET-49 (LWT 42), and BI-055 SRB's. Documentary photographs were taken of facility anomalies, potential sources of vehicle damaging debris, and vehicle configuration changes.

Due to the continued concern over potential hydrogen leakage from the ET/ORB LH2 umbilical interface area during cryoload and launch, tygon tubes for hydrogen leak detectors LD54 and LD55 were installed at the LH2 ET/ORB umbilical. The tygon tubes are intended to remain in place during cryogenic loading and be removed by the Ice Team during the T-3 hour hold.

There were no significant vehicle anomalies. At the time of the inspection, pad technicians were applying a K5NA repair to the aft skirt HDP #5 foot inner web stiffener. Total cure of the K5NA would not be complete prior to launch and an MRB approval was obtained.

There were no significant vehicle or facility debris issues. Flat foil-like particulate collectors had been taped to the top of each rainbird water deflector as part of an SRB plume study. The foil/tape was not a debris threat to the vehicle.

Six MLP deck handrails were secured to I-beams and railings in the northwest corner of the FSS 95 foot level as part of a new plan to retain handrails on the MLP deck late in the countdown.

The MLP deck and areas under the raised decks had not yet been vacuumed or swept to remove small debris items, such as sand, rust flakes, and paint chips. The work was accomplished prior to clearing the pad and no items were entered Appendix K of OMI S0007.

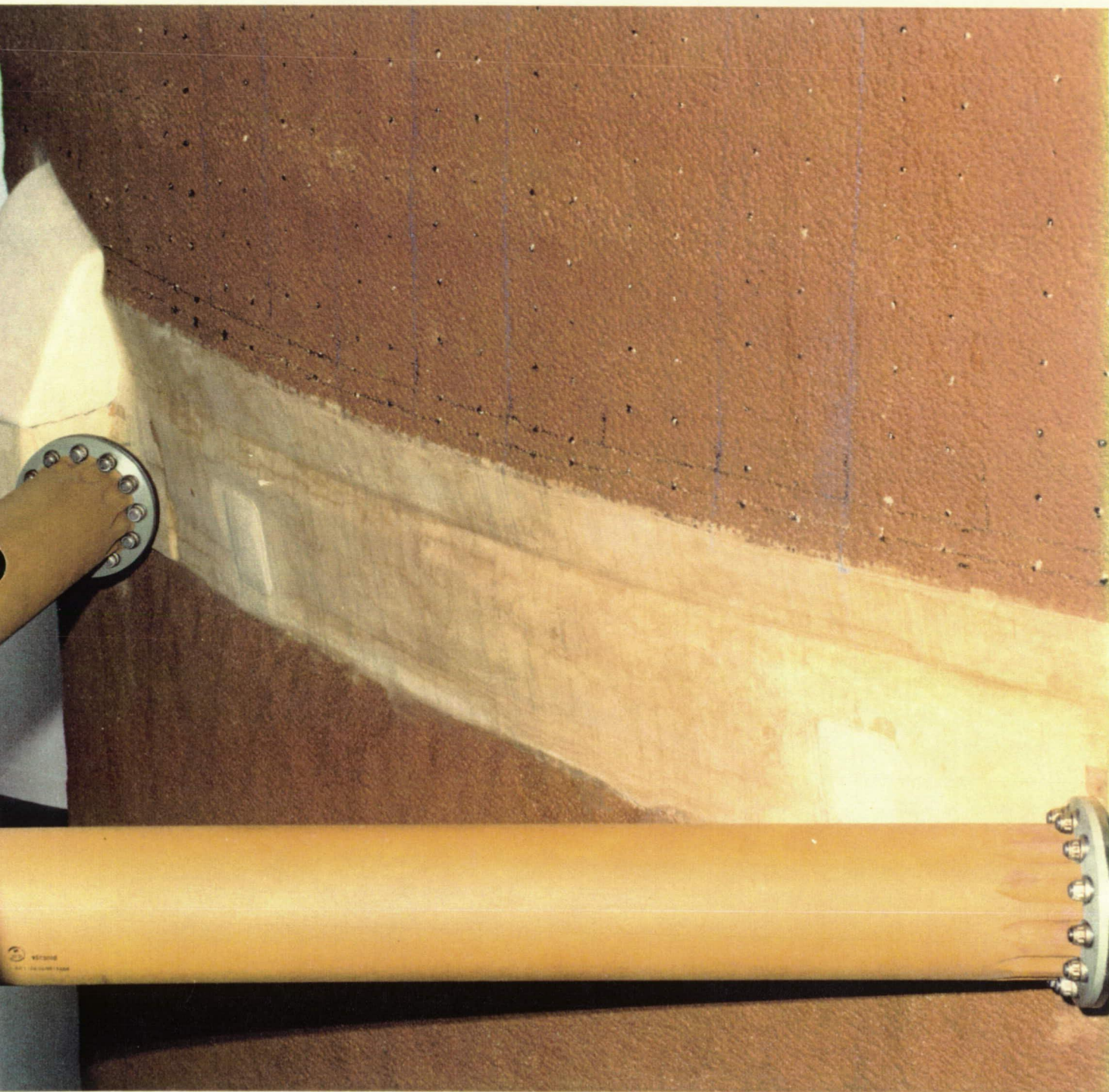

Pre-flight configuration of the bipod jack pad closeouts, the intertank TPS acreage, and the LH2 tank flange closeout.

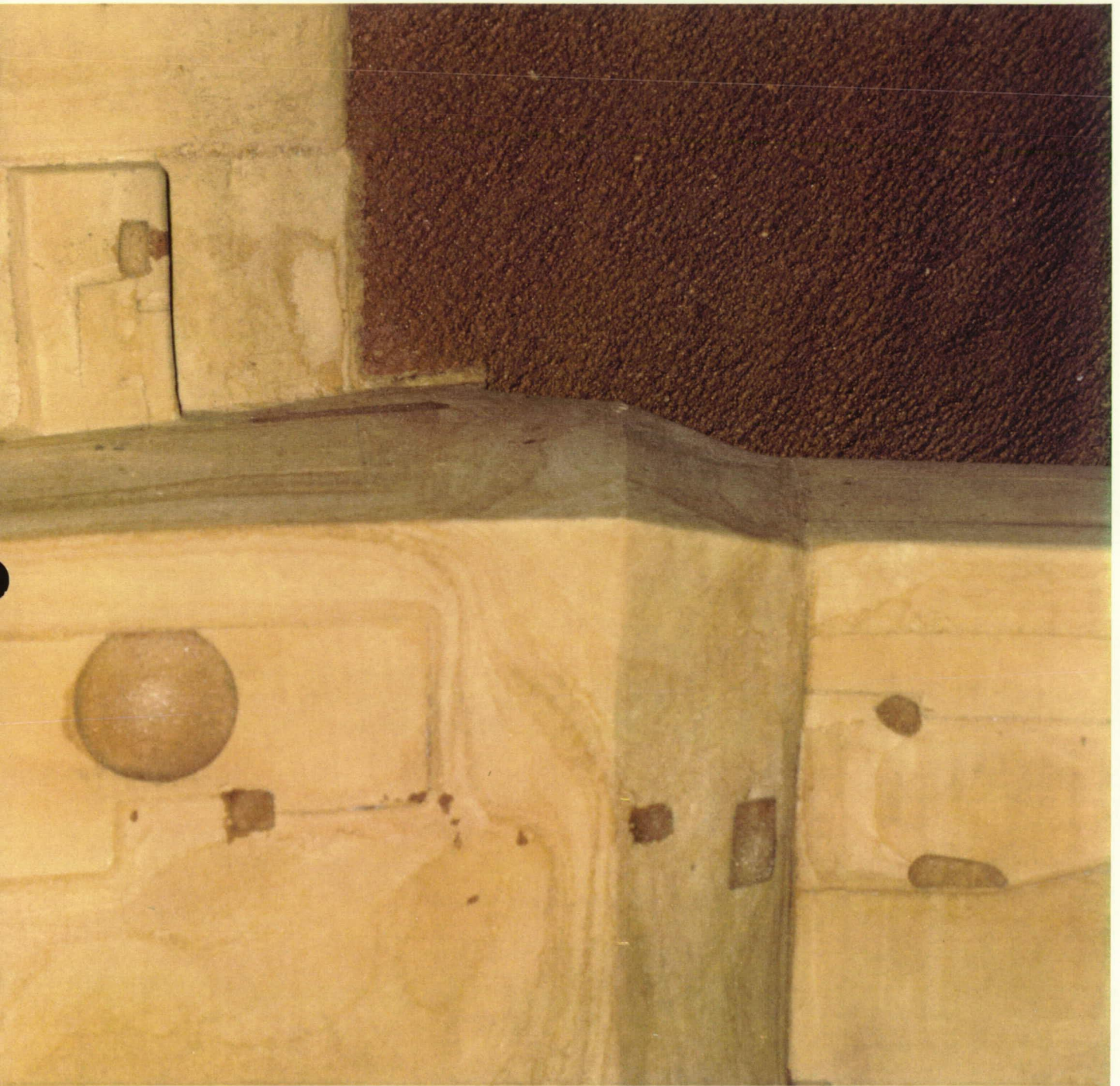

LH (-Y) vertical strut/cable tray TPS forward surface prior to cryogenic fuel loading. Cracks have appeared in this general area after cryoload due to the elimination of a stress relief gap as part of a manufacturing process enhancement change.



Flat, foil-like, particulate collectors had been taped to the top of each rainbird water deflector as part of an SRB plume study. The foil/tape was not a debris threat to the vehicle.

3.0 LAUNCH

STS-53 was launched at 13:23:59.993 GMT (8:24 a.m. local) on 2 December 1992.

3.1 ICE/FROST INSPECTION

The Ice/Frost Inspection of the cryoloaded vehicle was performed on 2 December 1992 from 0155 to 0400 hours during the two hour built-in-hold at T-3 hours in the countdown. There were no Launch Commit Criteria, OMRS, or NSTS-08303 violations with the exception of acreage ice/frost exceeding 0.0625 inches. There were no conditions outside of the established data base. Ambient weather conditions at the time of the Ice Inspection were:

Temperature:	46.4 Fahrenheit
Relative Humidity:	85.3 %
Wind Speed:	7.4 Knots
Wind Direction:	272 Degrees

A portable Shuttle Thermal Imager (STI) infrared scanning radiometer was utilized to obtain vehicle surface temperature measurements for an overall thermal assessment of the vehicle, as shown in Figures 1 and 2.

3.2 ORBITER

No Orbiter tile or RCC panel anomalies were observed. All RCS thruster paper covers and water spray boiler plugs were intact. Ice/frost formations were present at the SSME #1 and #2 heat shield-to-nozzle interfaces. Condensate was present on all SSME heat shields, but the base heat shield tiles were dry. An infrared scan revealed no unusual temperature gradients on the base heat shield or engine mounted heat shields. GOX vapors originating from inside the SSME nozzles was reported to MPS engineers and determined to be an expected condition.

3.3 SOLID ROCKET BOOSTERS

No SRB anomalies or loose ablator/cork were observed. The K5NA closeouts of the aft booster stiffener ring splice plates were intact. The STI portable infrared scanner recorded RH and LH SRB case temperatures as low as 46 degrees Fahrenheit (F). In comparison, temperatures measured by a hand-held Minolta/Land Cyclops spot radiometer reached a low of 45 degrees F and the SRB Ground Environment Instrumentation (GEI) measured temperatures as low as 51 degrees F. All measured temperatures were above the 34 degrees F minimum requirement.

Figure 2. **SSV INFRARED SCANNER
SURFACE TEMPERATURE
SUMMARY DATA**

TIME: APPROX. 0230 EST
 DATE: 12/2/92
 VEH. STS- 53

ALL MEASUREMENTS IN
 DEGREES FAHRENHEIT

TARGET EMISSIVITY
 ASSUMED TO BE 1.0

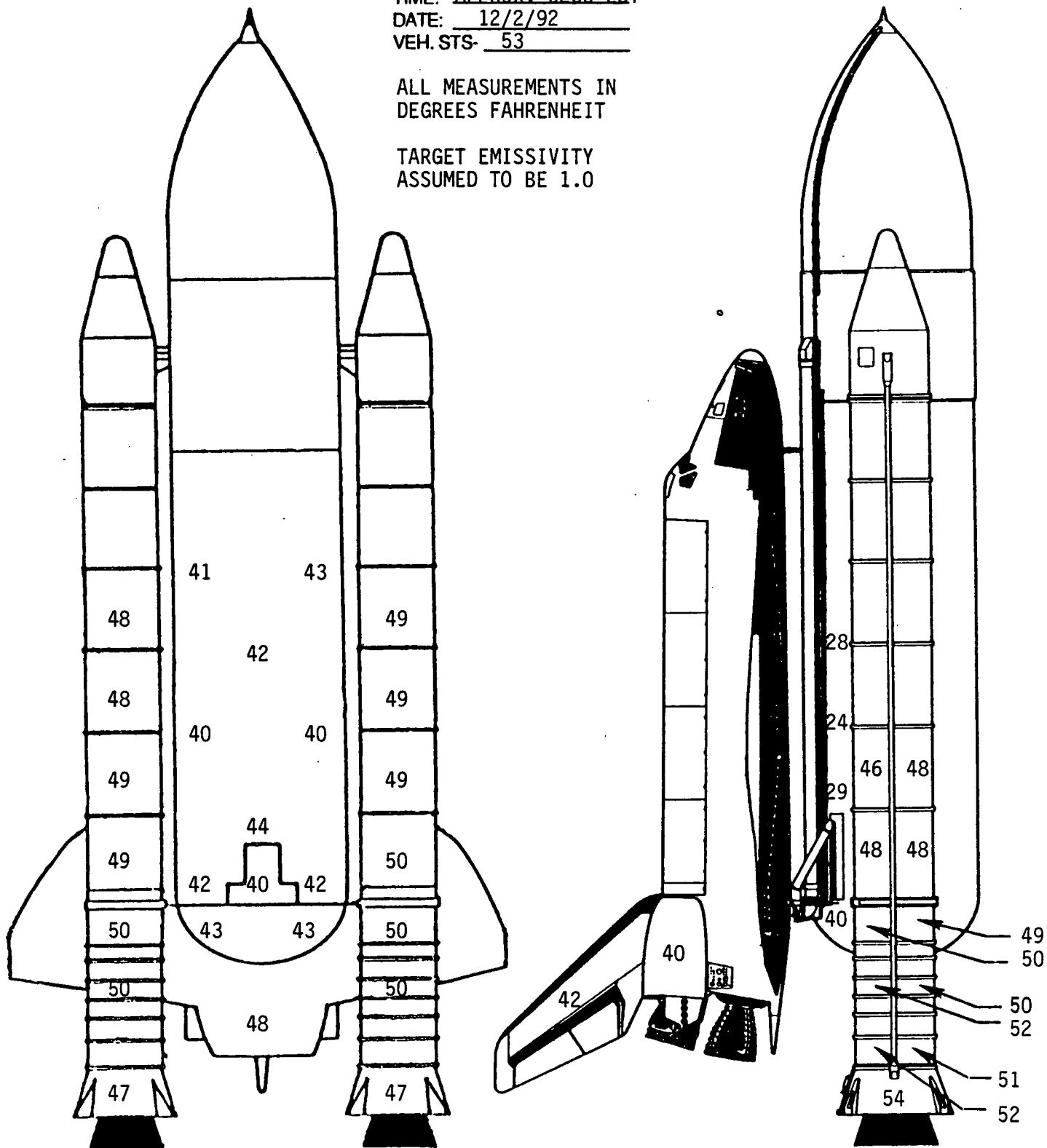

The predicted Propellant Mean Bulk Temperature (PMBT) supplied by MTI was 68 degrees F, which was within the required range of 44-86 degrees F.

3.4 EXTERNAL TANK

The ice/frost prediction computer program 'SURFICE' was run from 2300 to 0824 hours and the results tabulated in Figure 3. The program predicted condensate changing to ice/frost on the LO2 tank barrel section and the upper LH2 tank TPS acreage surfaces during the coldest time of night (0400-0700 local).

At the time of the Ice Inspection, condensate on the LO2 tank barrel section +Y+Z quadrant was freezing and changing to ice with a frost covering. Visually, the ice thickness appeared to exceed the 1/16 inch allowed in the LCC. There was no ice or frost in the "no ice" region. There were no TPS anomalies. The tumble valve cover was intact. The pressurization line and support ramps were in nominal configuration. SURFICE predicted temperatures of 33 degrees F on the ogive and 30 degrees F on the barrel.

There were no TPS anomalies on the intertank. Generally, the acreage TPS was dry. Ice/frost accumulated in the stringer valleys at the LH2 and LO2 tank-to-intertank flanges. Typical ice/frost formations, but no unusual vapors, were present on the ET umbilical carrier plate. The portable STI measured intertank surface temperatures that averaged 49 degrees F.

There were no LH2 tank TPS acreage anomalies. At the time of the Ice Inspection, condensate on the LH2 tank +Y+Z quadrant was freezing and changing to ice with a frost covering. Visually, the ice thickness appeared to exceed the 1/16 inch allowed in the LCC. Two sanded areas at XT-1250 and XT-1500 had a heavier coating of ice/frost due to the somewhat thinner TPS. Early in the inspection, the portable STI measured surface temperatures as low as 32 degrees F on the upper LH2 tank and 24 degrees F on the lower LH2 tank. SURFICE predicted temperatures of 25 degrees F on the upper LH2 tank and 32 degrees F on the lower LH2 tank.

There were no anomalies on the bipods, bipod jack pad closeouts, PAL ramp, cable tray/press line ice/frost ramps, longerons, thrust struts, manhole covers, or aft dome apex. Ice/frost had formed along the -Y bipod ramp closeout bondline. Two frost spots had formed on the -Y thrust strut-to-longeron interface. An ice/frost formation on the +Y longeron closeout was emitting vapors, but exhibited no offset. Some ice/frost was present in the ET/SRB cable tray-to-upper strut fairing expansion joints. Ice/frost covered the lower EB fittings outboard to the strut pin hole with condensate on the rest of the fitting. The struts were dry.

STS- 53	TEST	S0007 LAUNCH				DATE: 2 December 1992				T-0 TIME: 08:24:00				NASA											
ORBITER	ET	SRB	MLP	PAD	LO2				LH2				KSC												
103	49	BI-055	1	A	CHILLDOWN TIME: 22:59				FAST FILL TIME: 23:28				Ice/Frost/Debris												
CONDITIONS					LO2 TANK STA 370 TO 540				LO2 TANK STA 550 TO 852				LH2 TANK STA 1130 TO 1390												
TIME (EST)	TEMP F	REL HUM. %	DEW PT F	WIND VEL KNTS	WIND DIR DEG	WIND DEG	LOCAL REG	LOCAL VEL KNTS	SOF TEMP	COND RATE IN/HR	ICE RATE IN/HR	LOCAL REG	LOCAL VEL KNTS	SOF TEMP	COND RATE IN/HR	ICE RATE IN/HR	LOCAL REG	LOCAL VEL KNTS	SOF TEMP	COND RATE IN/HR	ICE RATE IN/HR				
2300	51.60	72.8	43.01	7	285	II	4.13	37.17	0.0012	-0.0228	III	4.13	31.80	0.0021	0.0031	III	3.01	27.12	0.0021	0.0198	II	8.47	36.95	0.0022	-0.0356
2315	50.80	75.0	43.02	7	282	II	4.13	36.68	0.0013	-0.0207	III	4.13	31.34	0.0021	0.0052	III	3.01	26.60	0.0022	0.0217	II	8.47	36.50	0.0024	-0.0324
2330	50.20	76.0	43.49	6	274	II	3.54	35.45	0.0014	-0.0139	III	3.54	29.66	0.0021	0.0118	II	2.58	24.48	0.0022	0.0288	II	7.26	35.06	0.0026	-0.0198
2345	49.20	79.4	42.98	8	278	II	4.72	36.57	0.0014	-0.0219	III	4.72	31.70	0.0023	0.0039	III	3.44	27.17	0.0024	0.0213	II	9.68	36.59	0.0026	-0.0386
0000	48.40	80.4	42.52	9	280	II	5.31	36.62	0.0014	-0.0240	III	5.31	31.90	0.0024	0.0005	III	3.87	27.83	0.0025	0.0201	II	10.89	36.78	0.0026	-0.0416
0015	48.40	81.6	42.92	10	283	II	5.90	37.45	0.0015	-0.0304	III	5.90	32.76	0.0026	0.0004	III	4.30	28.18	0.0028	0.0154	II	12.10	37.69	0.0027	-0.0539
0030	47.60	81.4	42.06	9	286	II	5.31	35.92	0.0015	-0.0204	III	5.31	31.45	0.0024	0.0054	III	3.87	27.12	0.0025	0.0230	II	10.89	36.10	0.0027	-0.0357
0045	47.20	81.2	41.60	8	291	II	4.72	34.69	0.0015	-0.0131	III	4.72	29.89	0.0023	0.0126	III	3.44	25.24	0.0024	0.0284	II	9.68	34.77	0.0027	-0.0223
0100	47.20	82.6	42.06	7	294	II	4.13	34.00	0.0015	-0.0090	III	4.13	28.77	0.0024	0.0166	III	3.22	24.64	0.0024	0.0296	II	8.61	34.05	0.0028	-0.0153
0115	46.60	81.8	41.20	10	297	II	5.90	35.56	0.0015	-0.0190	III	5.90	31.42	0.0025	0.0058	III	4.60	28.01	0.0025	0.0212	II	12.30	35.94	0.0026	-0.0379
0130	47.40	82.0	42.06	10	301	II	5.90	36.45	0.0015	-0.0248	III	5.90	31.90	0.0025	0.0005	III	4.60	28.90	0.0026	0.0172	II	12.30	36.81	0.0027	-0.0461
0145	48.00	81.8	42.52	10	299	II	5.90	37.05	0.0015	-0.0283	III	5.90	32.38	0.0026	0.0022	III	4.60	29.51	0.0026	0.0145	II	12.30	37.41	0.0027	-0.0519
0200	46.40	84.2	41.78	8	293	II	5.31	35.06	0.0016	-0.0190	III	5.31	30.64	0.0025	0.0099	III	4.14	26.96	0.0026	0.0244	II	11.07	35.39	0.0029	-0.0390
0215	45.80	86.0	41.55	8	278	II	4.72	33.68	0.0016	-0.0084	III	4.72	28.83	0.0025	0.0172	II	3.44	24.18	0.0025	0.0324	II	9.68	33.80	0.0030	-0.0148
0230	46.00	86.2	42.01	6	289	II	3.54	32.19	0.0016	-0.0008	III	3.54	28.34	0.0024	0.0247	III	2.58	20.90	0.0023	0.0378	III	7.26	31.90	0.0030	0.0003
0245	46.40	85.4	42.16	8	272	II	4.72	34.48	0.0016	-0.0120	III	4.72	29.66	0.0025	0.0137	II	3.44	24.96	0.0025	0.0295	II	9.68	34.57	0.0030	-0.0207
0300	46.80	85.2	42.29	8	273	II	4.72	34.66	0.0016	-0.0129	III	4.72	29.87	0.0025	0.0128	III	3.44	25.19	0.0025	0.0288	II	9.68	34.75	0.0030	-0.0222
0315	46.40	84.6	41.90	7	275	II	4.13	33.44	0.0016	-0.0066	III	4.13	28.22	0.0024	0.0190	III	3.01	23.17	0.0024	0.0335	II	8.47	33.39	0.0029	-0.0103
0330	46.40	85.0	42.03	7	278	II	4.13	33.50	0.0016	-0.0068	III	4.13	28.28	0.0024	0.0188	III	3.01	23.23	0.0024	0.0333	II	8.47	33.45	0.0029	-0.0108
0345	46.20	85.2	41.89	7	282	II	4.13	33.32	0.0016	-0.0060	III	4.13	28.06	0.0024	0.0186	III	3.01	23.03	0.0024	0.0338	II	8.47	33.28	0.0029	-0.0095
0400	46.00	86.6	42.13	5	249	III	2.95	31.36	0.0015	0.0039	III	2.95	24.30	0.0022	0.0293	III	2.15	18.41	0.0021	0.0413	III	6.06	30.87	0.0028	0.0066
0415	46.00	87.6	42.44	6	243	III	3.54	32.38	0.0017	-0.0016	III	3.54	26.56	0.0024	0.0239	III	1.92	16.84	0.0020	0.0408	II	8.16	33.12	0.0031	-0.0081
0430	45.20	88.6	41.95	6	242	III	3.54	31.90	0.0016	0.0003	III	3.54	25.81	0.0024	0.0267	III	1.92	16.02	0.0020	0.0449	II	8.16	32.45	0.0032	-0.0032
0445	46.00	87.8	42.50	9	256	II	5.31	35.17	0.0018	-0.0185	III	5.31	30.76	0.0027	0.0093	III	3.87	28.31	0.0027	0.0283	II	10.89	35.40	0.0032	-0.0287
0500	46.40	86.2	42.41	7	256	II	4.13	33.66	0.0016	-0.0076	III	4.13	28.46	0.0025	0.0181	III	3.01	23.41	0.0024	0.0327	II	8.47	33.62	0.0030	-0.0121
0515	46.00	86.8	42.19	6	241	II	3.54	32.28	0.0016	-0.0012	III	3.54	26.43	0.0024	0.0243	III	1.92	16.73	0.0020	0.0432	II	8.16	33.00	0.0031	-0.0073
0530	45.80	87.8	42.30	6	248	II	3.54	32.20	0.0017	-0.0009	III	3.54	26.36	0.0024	0.0246	III	2.58	20.90	0.0023	0.0378	III	7.26	31.90	0.0031	0.0002
0545	45.80	89.2	42.73	5	242	III	2.95	31.51	0.0016	0.0034	III	2.95	24.45	0.0023	0.0289	III	1.60	16.46	0.0020	0.0458	III	6.80	31.90	0.0031	0.0005
0600	45.80	88.4	42.49	6	217	II	3.54	32.28	0.0017	-0.0012	III	3.54	26.45	0.0024	0.0243	III	1.92	16.71	0.0020	0.0433	II	8.16	33.03	0.0032	-0.0074
0615	45.20	90.4	42.49	6	213	III	3.54	31.90	0.0017	0.0002	III	3.54	26.08	0.0025	0.0258	III	1.92	16.26	0.0020	0.0444	II	8.16	32.70	0.0033	-0.0050
0630	45.20	92.2	43.02	7	242	III	4.13	33.23	0.0019	-0.0056	III	4.13	28.04	0.0027	0.0200	III	2.24	18.84	0.0023	0.0411	II	9.52	34.16	0.0035	-0.0174
0645	45.60	92.6	43.53	7	240	III	4.13	33.70	0.0019	-0.0078	III	4.13	28.54	0.0027	0.0180	III	2.24	19.37	0.0023	0.0397	II	9.52	34.66	0.0035	-0.0212
0700	45.60	92.4	43.47	7	231	II	4.13	33.67	0.0019	-0.0078	III	4.13	28.51	0.0027	0.0181	III	2.24	19.34	0.0023	0.0397	II	9.52	34.63	0.0035	-0.0210
0715	46.20	92.8	44.19	7	222	II	4.13	34.39	0.0019	-0.0107	III	4.13	28.23	0.0028	0.0151	III	2.24	20.12	0.0023	0.0377	II	9.52	35.36	0.0036	-0.0265
0730	46.40	91.2	43.92	8	238	II	4.72	35.33	0.0018	-0.0161	III	4.72	30.59	0.0028	0.0098	III	2.56	21.99	0.0024	0.0346	II	10.88	36.34	0.0035	-0.0379
0745	47.40	90.6	44.74	6	233	II	3.54	34.29	0.0018	-0.0093	III	3.54	28.56	0.0026	0.0165	III	1.92	19.05	0.0022	0.0378	II	8.16	35.06	0.0034	-0.0217
0800	48.60	88.6	45.33	7	229	II	4.13	36.45	0.0018	-0.0197	III	4.13	31.22	0.0027	0.0063	III	2.24	22.38	0.0023	0.0314	II	9.52	37.33	0.0034	-0.0420
0815	50.80	88.4	47.25	7	207	II	4.13	38.65	0.0019	-0.0295	III	4.13	32.68	0.0029	-0.0032	III	2.24	24.73	0.0024	0.0248	II	9.52	39.48	0.0036	-0.0592
T-0	51.00	87.2	47.28	7	198	II	4.13	38.90	0.0019	-0.0306	III	4.13	32.94	0.0028	-0.0043	III	2.94	28.55	0.0027	0.0153	III	2.66	27.28	0.0026	0.0187

AVG. 47.11 85.52 42.86 7.33 4.33 34.55 4.33 28.28 2.93 23.07 9.10 34.56

Period of Ice Team Inspection

Figure 3. "SURFICE" Computer Predictions

A crack that extended 2/3 the width of the -Y vertical strut cable tray was present in the forward surface TPS near the longeron closeout interface. Although jagged in appearance, the crack exhibited no offset and was not filled with ice or frost. The appearance of the crack was expected due to the elimination of the stress relief gap at the factory.

Typical amounts of ice/frost were present in the L02 feedline bellows and support brackets. In addition, frost covered some parts of the L02 feedline acreage.

There were no TPS anomalies on the L02 ET/ORB umbilical. The purge barrier (baggie) was configured properly and was holding positive purge pressure. There were light accumulations of ice/frost on the acreage areas of the umbilical. Formation of ice/frost on the separation bolt pyrotechnic canister purge vents was typical. Normal venting of nitrogen purge gas had occurred during tanking, stable replenish, and launch.

Ice/frost in the LH2 recirculation line bellows and on both burst disks, and in the LH2 feedline bellows, was typical. The LH2 feedline straight section (spool) was also covered by ice/frost - a condition that is not expected unless the ambient temperature falls below 32 degrees F.

Somewhat greater than usual amounts of ice/frost had accumulated on the top, aft, and outboard sides of the LH2 ET/ORB umbilical/purge barrier. Typical ice/frost fingers had formed on the pyro canister and plate gap purge vents. Ice/frost was present on both the aft and forward outboard pyrotechnic canister closeout bondlines indicating thermal shorts. Some venting was occurring at the forward outboard location. The amount and location of the ice/frost was acceptable for launch per the NSTS-08303 criteria. A 2-inch ice/frost finger had formed on the cable tray vent hole. The 17-inch flapper valve actuator access port foam plug closeout exhibited a slight leak at the forward corner and was covered by ice/frost. No unusual vapors or cryogenic drips had appeared during tanking, stable replenish, and launch.

The ET/ORB hydrogen detection sensor tygon tubing was in proper position prior to removal. The tubing was successfully removed from the vehicle without contacting Orbiter tiles.

Due to the concern of exceeding the 47 degree (F) ambient temperature limit as listed in the Launch Commit Criteria, the Ice Team took dry and wet bulb temperature measurements on the MLP deck and at most levels of the FSS. The measurements were reported to the Firing Room real-time for incorporation into the Air Force weather prediction model and for comparison to other sources of local temperature data.

The summary of Ice/Frost Team observations/anomalies consisted of nine OTV recorded items:

Anomaly 001 documented a crack in the forward surface TPS covering of the -Y vertical strut cable tray at the intersection to the ET/SRB cable tray transition fairing. The crack exhibited no offset and was not filled with ice or frost. The condition was acceptable for launch per NSTS-08303 and CR S041254C.

Anomaly 002 recorded ice accumulation on the +Y+Z quadrant acreage of both LO2 and LH2 tanks. Ice Team observations determined the ice thickness exceeded 0.0625 inches, which was an LCC violation. Launch was delayed until ambient warming melted the ice/frost formations. A second on-pad visual inspection at 0730 hours revealed ice/frost conditions were acceptable for launch.

Anomaly 003 documented ice/frost formations on both +Y and -Y longeron closeout bondlines, in the thrust strut-to-longeron interface, and on a subsurface defect (+Y side only). The ice and frost formations were acceptable per NSTS-08303.

Anomaly 004 (documentation only) recorded ice/frost formations in the intertank stringer valleys at both LO2 tank and LH2 tank flange closeouts. The presence of the ice/frost was acceptable per NSTS-08303.

Anomaly 005 (documentation only) recorded ice/frost formations in the LO2 feedline bellows and support brackets. The ice/frost formations were acceptable per NSTS-08303.

Anomaly 006 (documentation only) recorded ice/frost fingers on the LO2 ET/ORB umbilical pyro canister purge vents. The ice and frost formations were acceptable per NSTS-08303.

Anomaly 007 (documentation only) recorded ice/frost formations on the LH2 ET/ORB umbilical pyro canister purge vents, purge barrier (baggie), plate gap purge vents, cable tray vent hole; LH2 feedline bellows; and LH2 recirculation line bellows and burst discs. The ice/frost formations were acceptable per NSTS-08303.

Anomaly 008 documented two small (less than 0.5 inch) icicles on the north GOX vent duct. With the prevailing wind out of the southwest at 229 degrees, no threat to Orbiter tiles existed.

Anomaly 009 recorded ice/frost formations on the LH2 tank aft dome manhole covers. The condition was acceptable per NSTS-08303.

3.5 FACILITY

All SRB sound suppression water troughs were filled and properly configured for launch. There was no debris on the MLP deck or in the SRB holddown post areas with the exception of a welder's cable found in the FSS 195 foot level restroom.

No leaks were observed on either the LO2 or LH2 Orbiter T-0 umbilicals. Typical accumulations of ice/frost were present on the cryogenic lines and purge shrouds. There was also no apparent leakage anywhere on the GH2 vent line or GUCP. The GH2 vent line modification prevented ice from forming. But some ice/frost, which was expected, had accumulated on the GUCP legs and on the uninsulated parts of the umbilical carrier plate.

Visual and infrared observations of the GOX seals confirmed no leakage. No ET nosecone/footprint damage was visible after the GOX vent hood was retracted. No icicles were present on the GOX vent ducts at the time of launch.

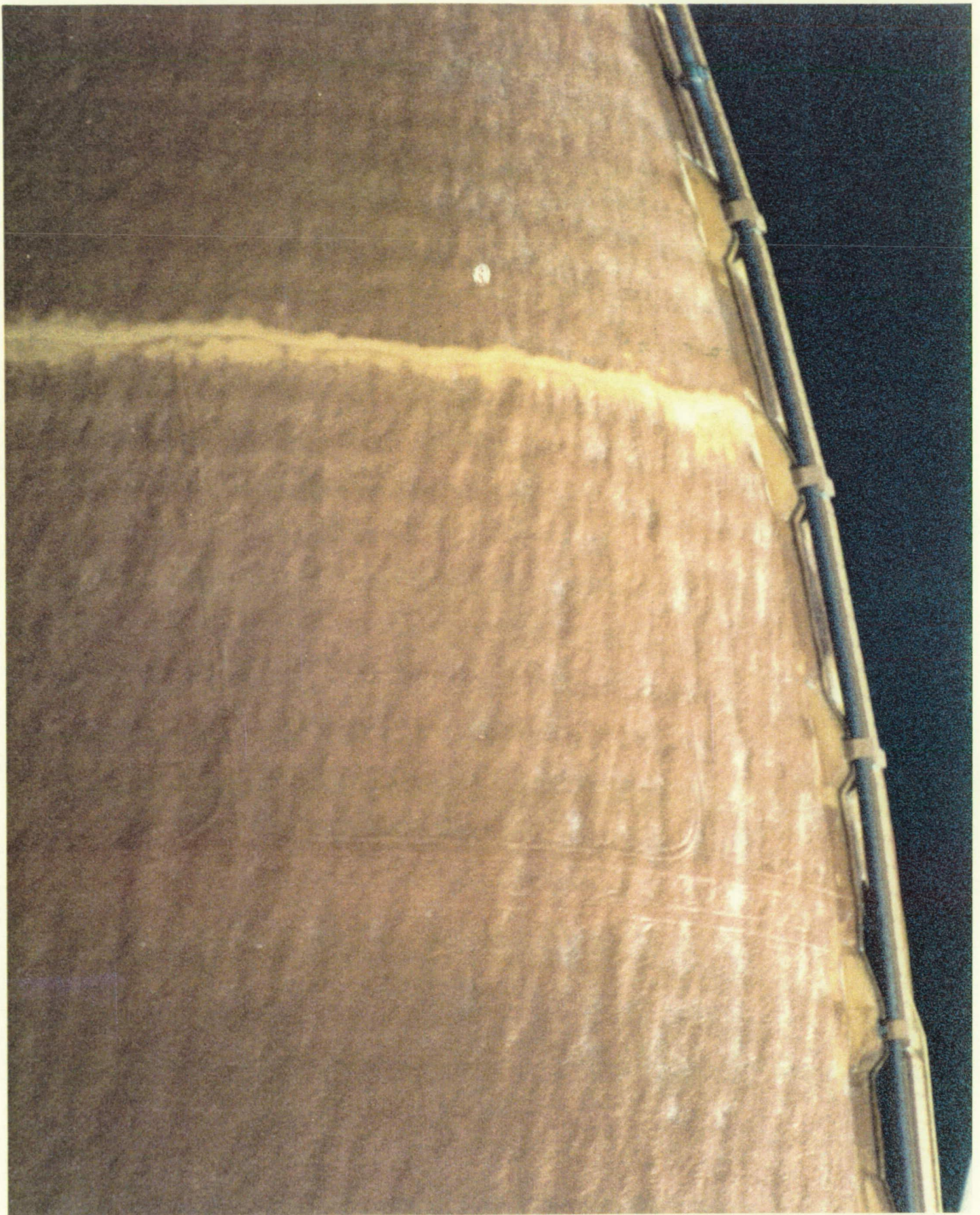

At the time of the Ice Inspection, condensate on the LO2 tank barrel section +Y+Z quadrant was freezing and changing to ice with a frost covering. The ice thickness exceeded the 1/16 inch allowed in the LCC.

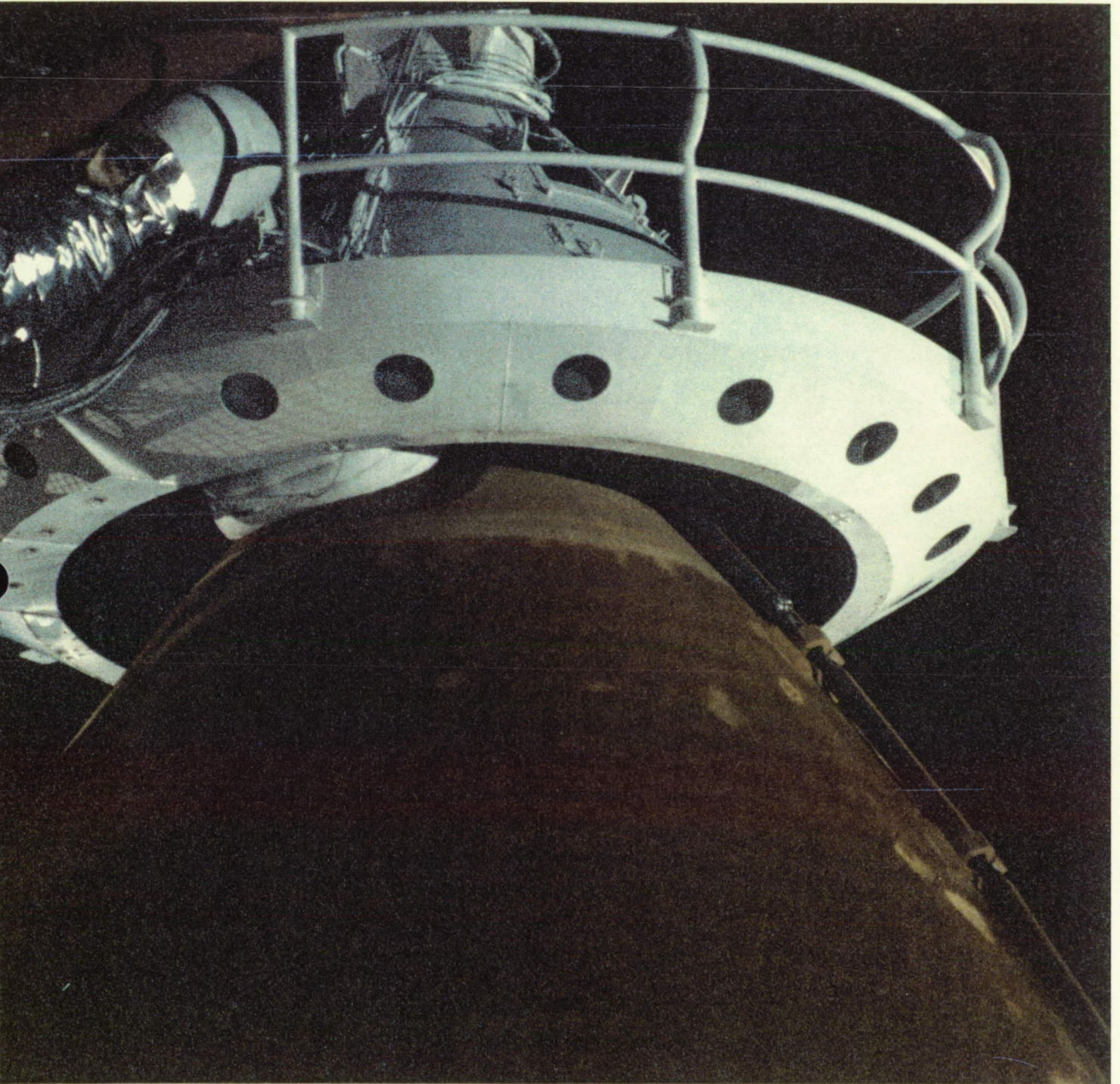

The thicker TPS on the LO2 tank ogive prevented ice or frost from forming in the "no ice" region. There were no anomalies on the LO2 tank TPS.

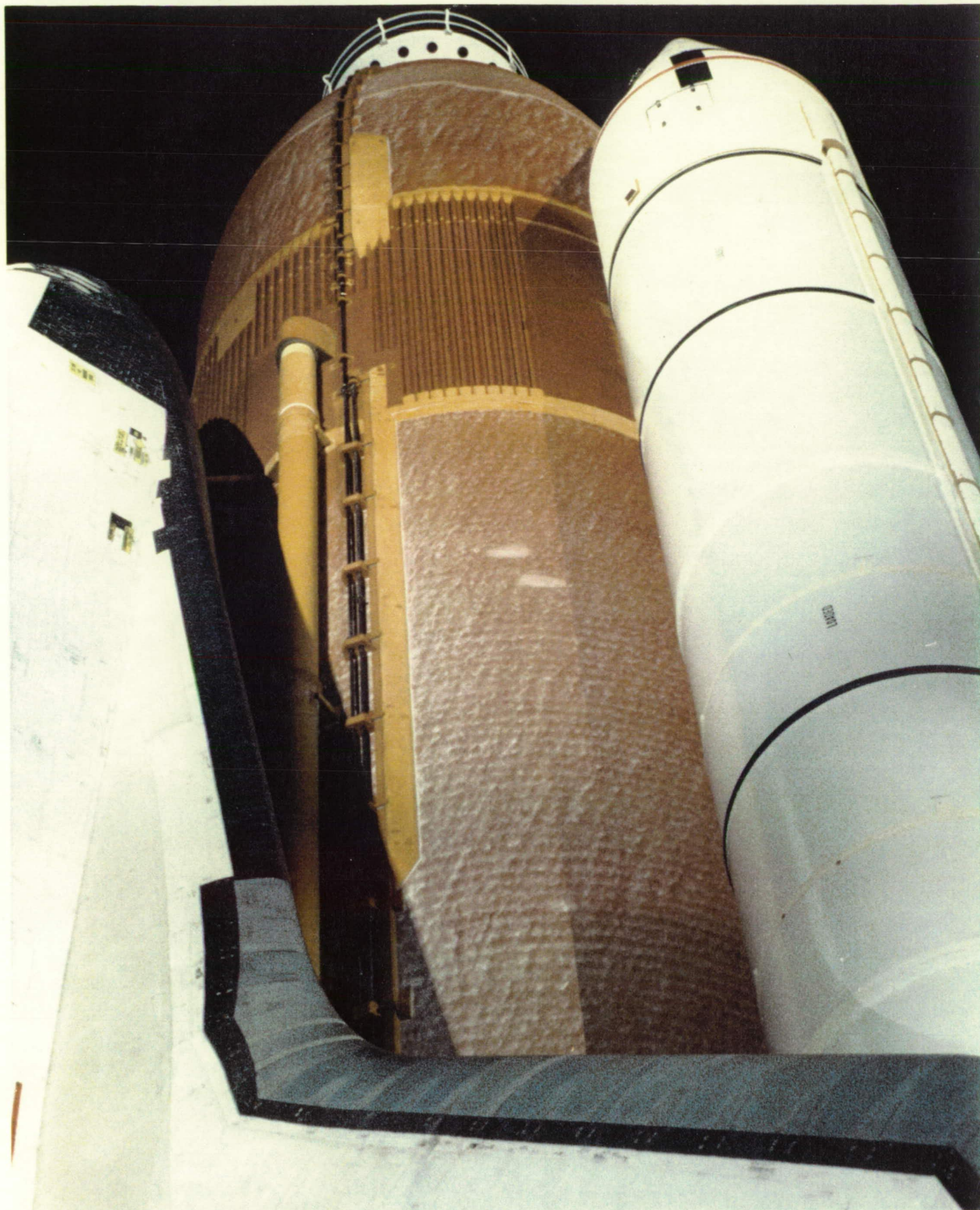

At the time of the Ice Inspection, condensate on the LH2 tank +Y+Z quadrant was freezing and changing to ice with a frost covering. The ice thickness exceeded the 1/16-inch allowed in the LCC.

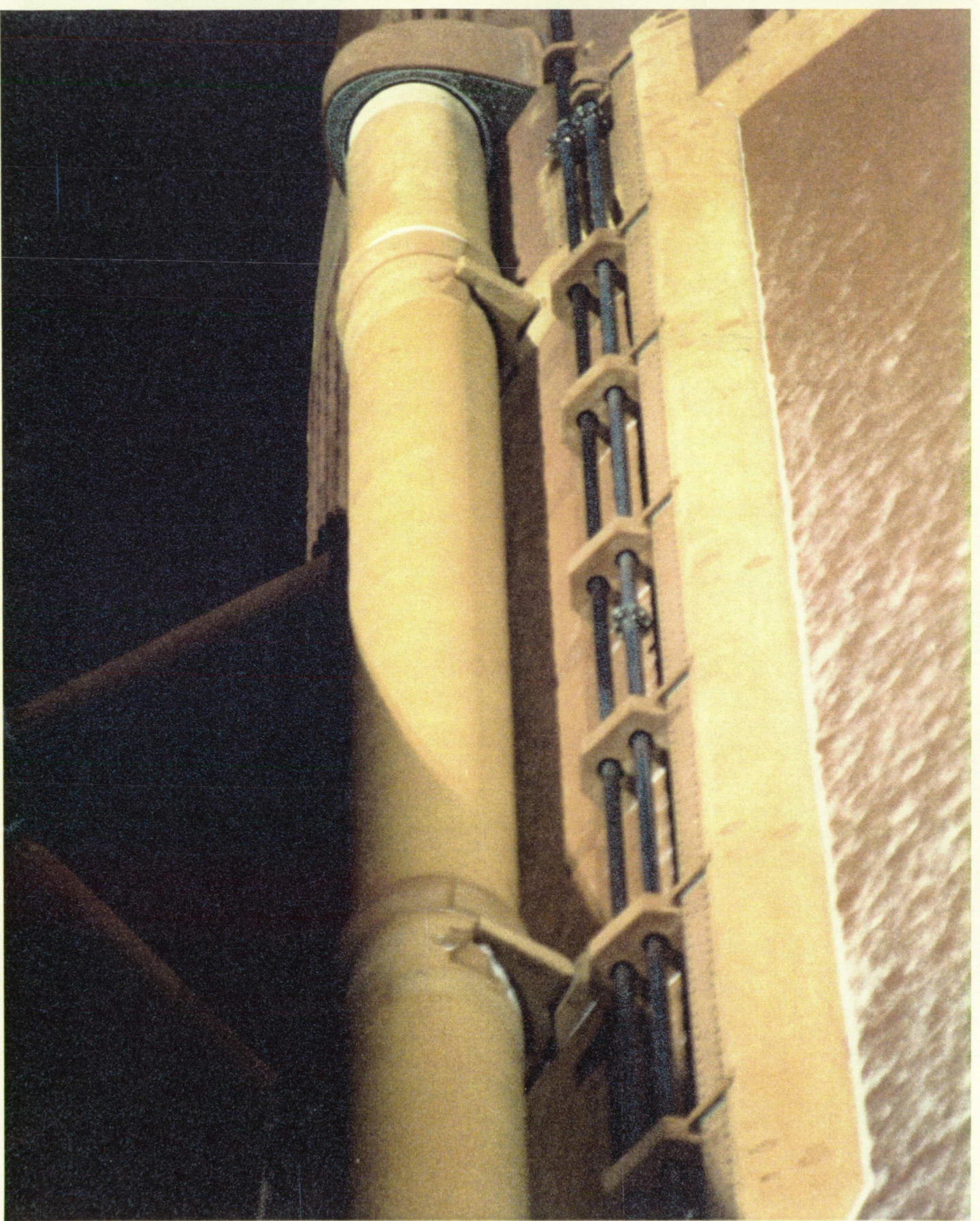

Ice/frost formed along the bondlines of the PAL ramp and some of the pressurization line/cable tray ramps. Ice/frost was also present in the L02 feedline upper bellows and support brackets.

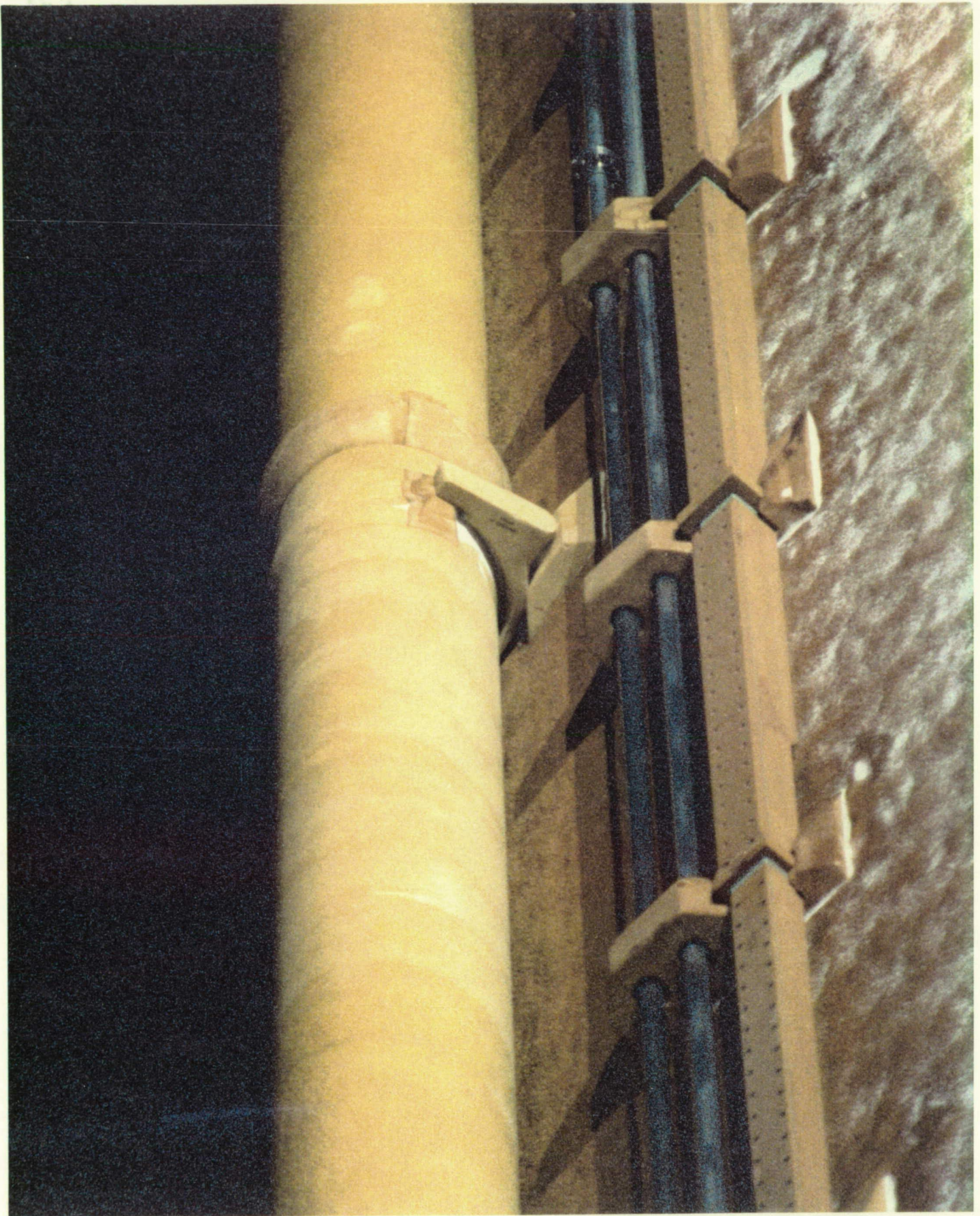

Ice/frost had formed on the LH2 tank acreage, in the L02 feed line support brackets, and along the cable tray ramps

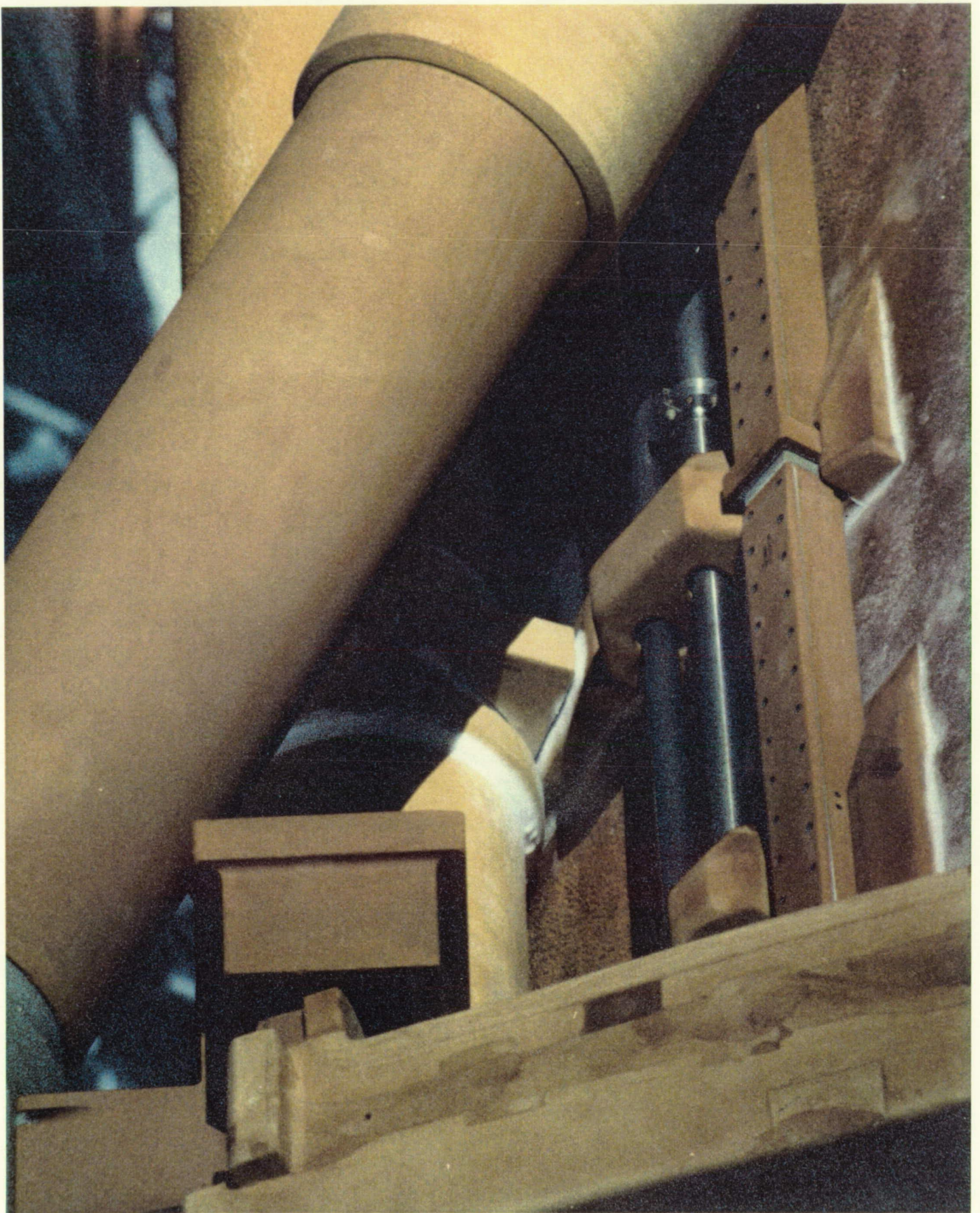

Ice/frost had formed on the lower LH2 tank TPS acreage, in the L02 feedline lower bellows and support brackets, and on some of the L02 feedline acreage areas.

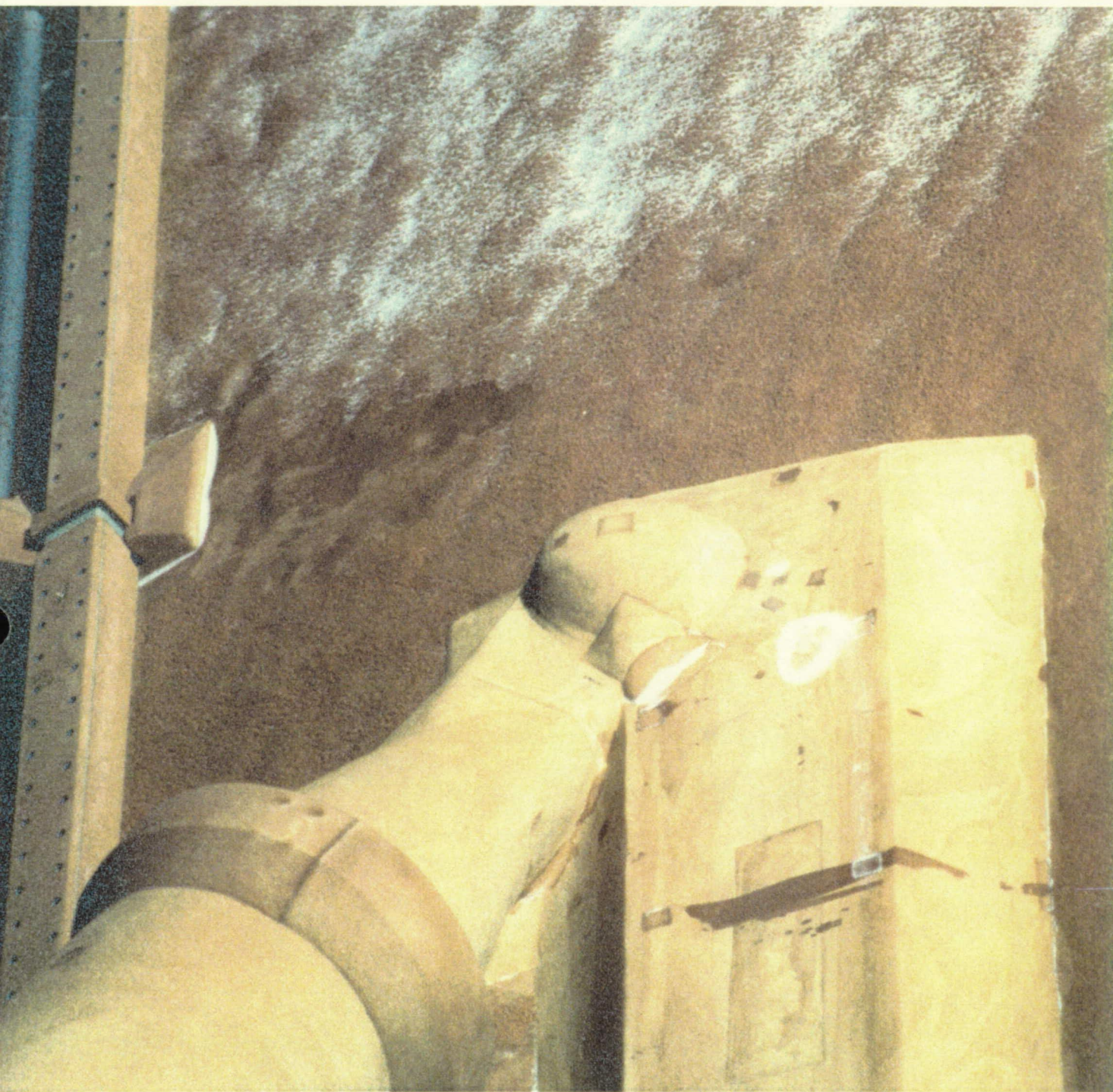

Ice/frost had formed on the lower LH2 tank TPS acreage and along the cable tray ramp bondline closeouts. An ice/frost formation on the +Y longeron closeout was emitting vapors, but exhibited no offset.

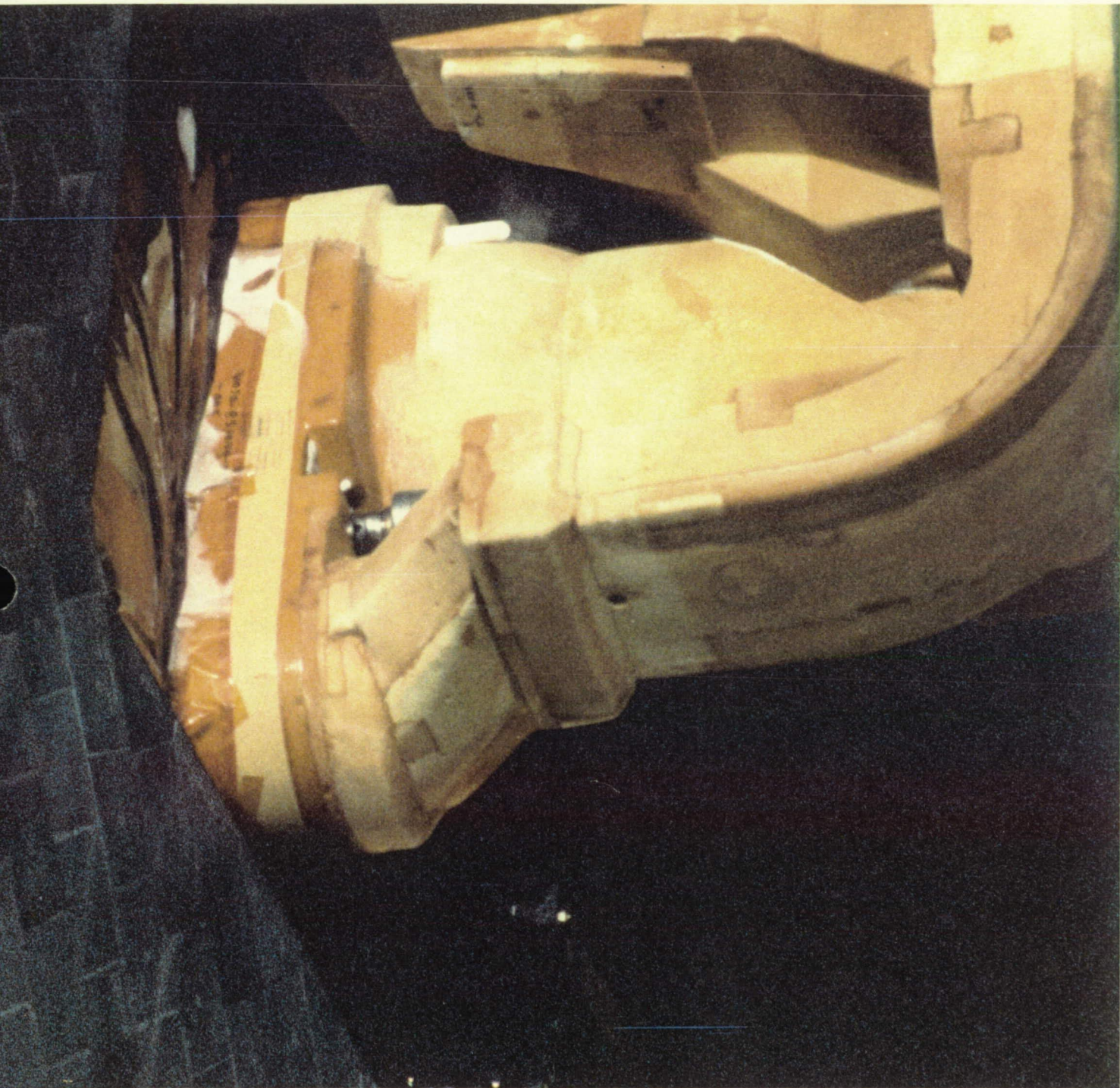

There were no TPS anomalies on the LO2 ET/ORB umbilical. There were light accumulations of ice/frost on the TPS acreage areas and on the purge barrier (baggie).

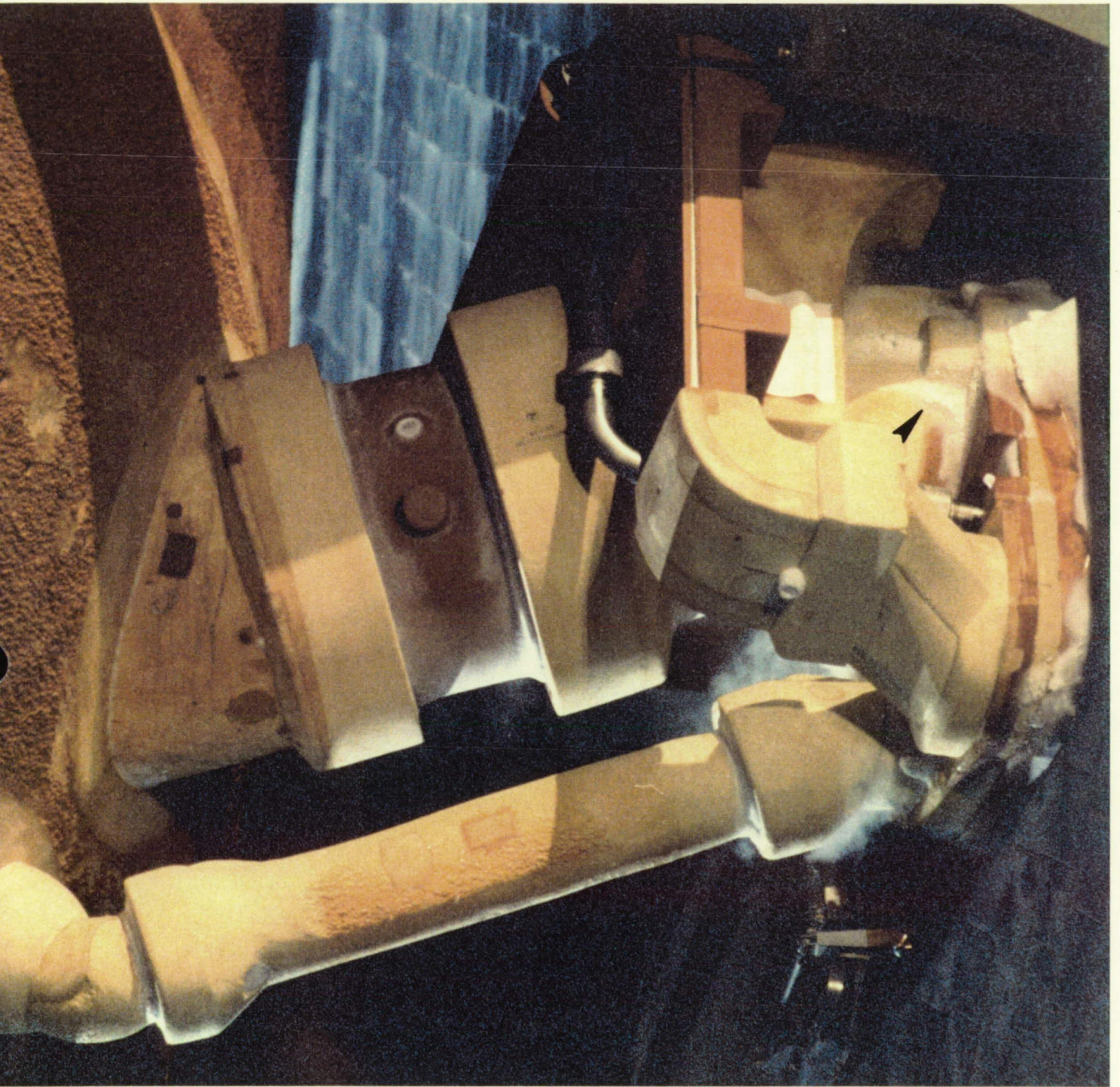

Somewhat greater than usual amounts of ice/frost had formed on the top, aft, and outboard sides of the LH2 ET/ORB umbilical/purge barrier. Normal amounts of ice/frost had accumulated on the plate gap and pyrotechnic canister purge vents, and the LH2 recirculation line bellows/burst disks. Ice was present on the forward outboard pyrotechnic canister closeout bondline indicating a thermal short (arrow). Frost was beginning to form on the LH2 feedline straight section (spool).

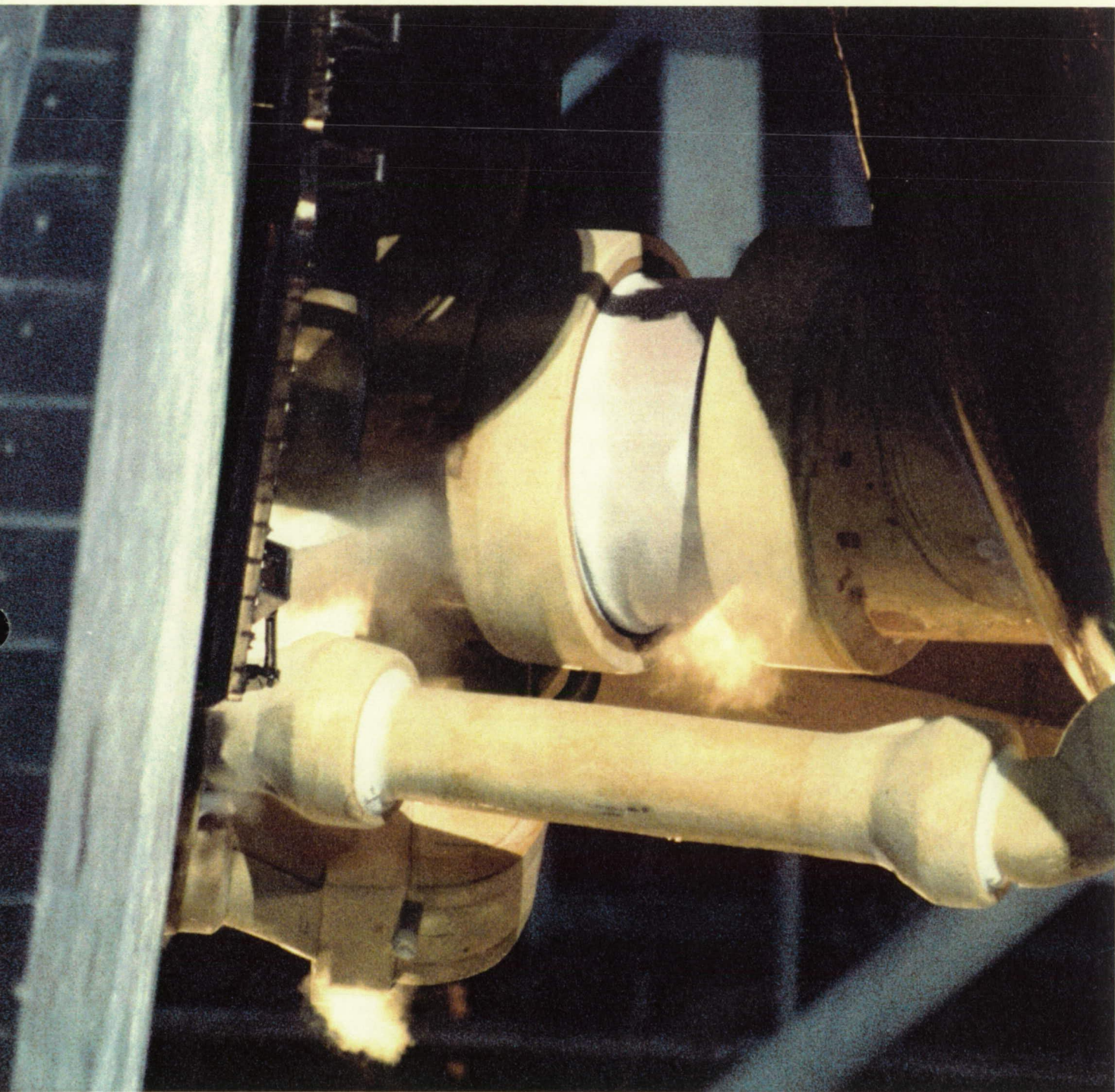

Ice/frost continued to form and accumulate in the LH2 recirculation line bellows. By the end of the Ice Inspection, the LH2 feedline straight section (spool) was almost completely covered by ice/frost, a condition that should not occur until the ambient temperature falls below 32 degrees F.

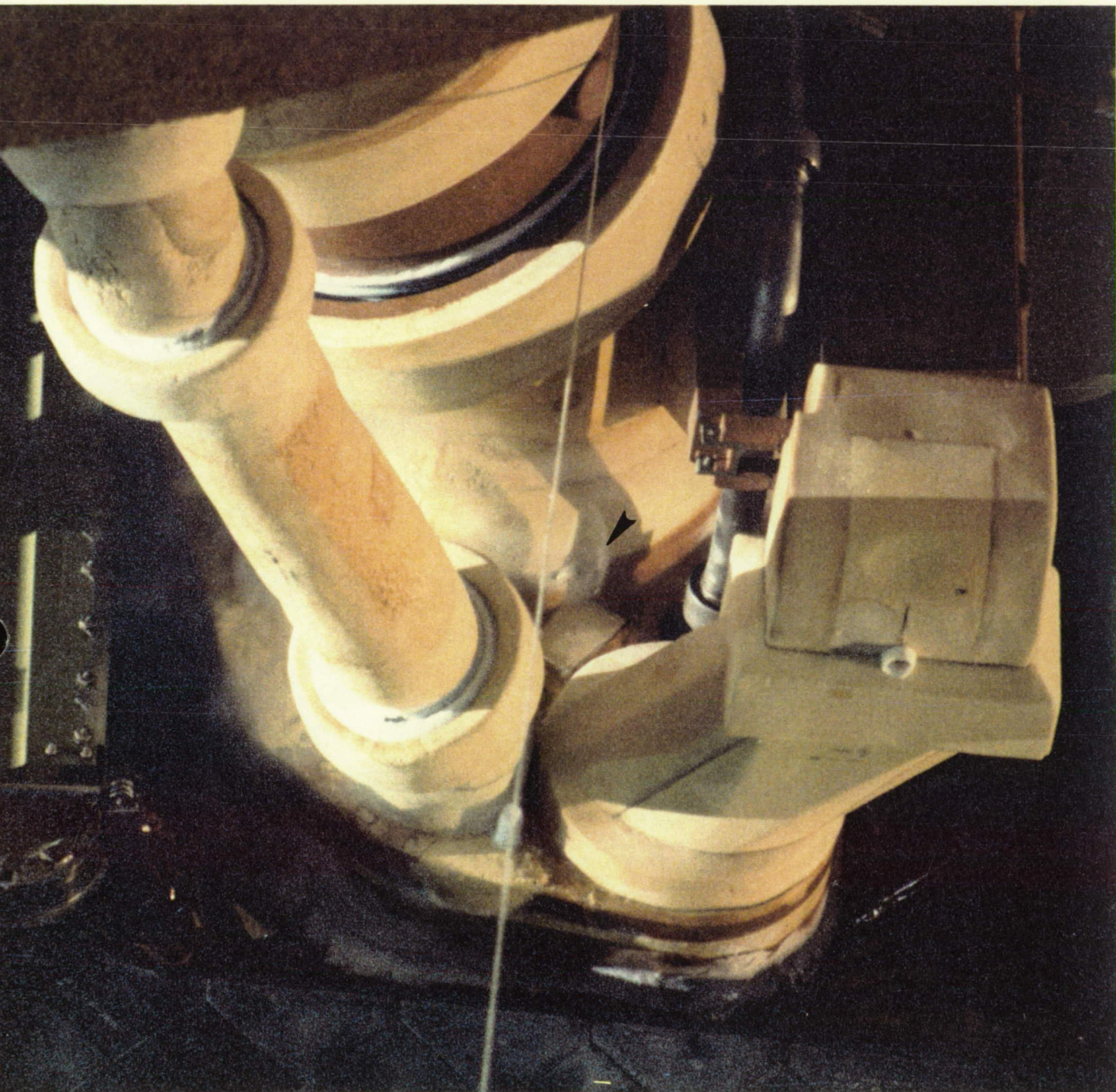

Typical in size, ice/frost fingers had formed on the aft plate gap purge vent and LH2 umbilical cable tray vent hole. Some ice and frost had formed at the forward corner of the 17-inch flapper valve actuator access port TPS plug closeout indicating a small purge gas leak at the bondline.

4.0 POST LAUNCH PAD DEBRIS INSPECTION

The post launch inspection of the MLP, FSS, and the pad acreage was conducted on 2 December 1992 from Launch + 1-3/4 to 3-1/2 hours. No flight hardware or TPS materials were found with the exception of one Orbiter base heat shield Q-felt plug on the southwest pad apron slope.

SRB holddown post erosion was less than normal. All south HDP shoe shim material was intact, but slightly debonded at the sidewalls of HDP #1, #2, #5, and #6. There was no visual indication of a stud hang-up on any of the south holddown posts. There were no ordnance fragments found in the south holddown post stud holes. All of the north HDP doghouse blast covers were in the closed position and exhibited typical erosion. The SRB aft skirt purge lines were in place, but slightly damaged. The SRB T-0 umbilicals exhibited minor damage.

The GOX vent arm, OAA, and TSM's showed only minor damage. The GH2 vent arm was latched on the seventh tooth of the latching mechanism and had no loose cables (static retract lanyard). The GH2 vent line appeared to have retracted nominally, though the north latch had contacted the north saddle stabilizer. The damage from this contact was minimal and has occurred on previous launches. The GH2 vent line showed typical signs of SRB plume impingement. The ET intertank access structure also sustained typical plume heating effects.

Damage to the facility included:

1. A lighting fixture from the northeast corner of the FSS 95 foot level was found on the north side of the same level beneath the stairs.
2. An FSS 255 foot level sign was detached and found on the east side of the 255 foot level.
3. The FSS 155 foot sign on the east wall of the elevator structure was loose.
4. The OIS box door on the southwest corner of the FSS 235 foot level was damaged.
5. A UV Flame Detector was found on the northwest corner of the pad apron.

All seven emergency egress slidewire baskets were secured on the FSS 195 foot level and sustained no launch damage.

The six MLP deck handrails stowed on the northwest corner of the FSS 95 foot level for this launch were intact. However, further review of this plan has determined that all MLP deck handrails will normally be removed from the pad prior to launch. A back-up plan provides the option of securing handrails on the FSS 95 foot level, if required.

An inspection of the beach from UCS-10 to Titan complex 40, the beach road, the railroad tracks, and the water areas around the pad and under the flight path was completed. No flight hardware was found.

MLP-1 was configured with overpressure sensors at the top of both TSM's, at the bottom of both SRB exhaust holes, and at the top of the SSME exhaust hole. All sensor readings were consistent with previous launches and within nominal limits.

Patrick AFB and MILA radars were configured in a mode for increased sensitivity for the purpose of observing any debris falling from the vehicle during ascent but after SRB separation (due to the masking effect of the SRB exhaust plume). Most of the signal registrations were very weak and often barely detectable, which generally compares with the types of particles detected on previous Shuttle flights. A total of 69 particles were imaged in the T+142.5 to 362.5 second time period. Fifteen of the particles were imaged by only one radar, 30 particles were imaged by two radars, and 24 particles were imaged by all three radars. The number and signal strength of the detected particles was comparable to the STS-52 mission (74 particles).

Post launch pad inspection anomalies are listed in Section 9.

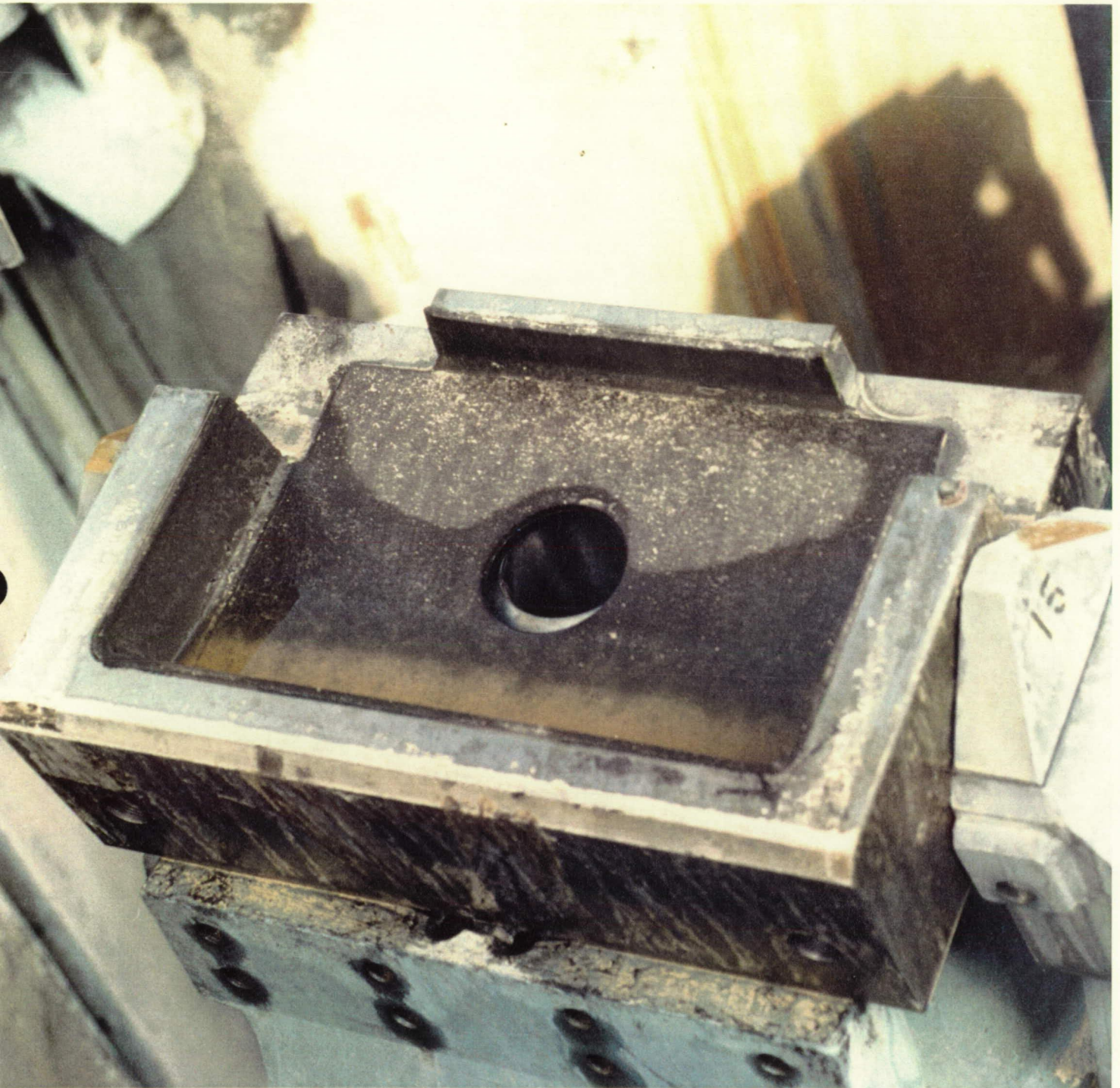

Plume erosion of the south SRB holddown posts was typical. EPON shim material was intact but slightly debonded from the sidewalls of the holddown post shoes.



Deletion of aft skirt strain gauges resulted in less electrical connector sacrificial pieces on the SRB T-0 umbilical exposed to the SRB plume.

5.0 FILM REVIEW AND PROBLEM REPORTS

Post Launch Anomalies observed in the Film Review were presented to the Mission Management Team, Shuttle managers, and vehicle systems engineers. These anomalies are listed in Section 9.

5.1 LAUNCH FILM AND VIDEO SUMMARY

A total of 102 film and video data items, which included thirty-eight videos, thirty-nine 16mm films, twenty-one 35mm films, and four 70mm films, were reviewed starting on launch day.

No major vehicle damage or lost flight hardware was observed that would have affected the mission.

Numerous camera views showed that ice accumulation on the Orbiter side of the External Tank had melted prior to the time of lift off. Ice/frost covered a substantial part of the ET -Z side LH2 tank, but was not a concern for launch (OTV 033, 060, 065, 066).

SSME ignition, Mach diamond formation, and gimbal profile appeared normal (RSS STI, C/S-2 STI, OTV 051, 063, 070).

Orange vapor (burning hydrogen) was visible between the exit plane and the #9 hatband near the steer horn, or the coolant manifold, on the SSME #2 nozzle -Z side. This event is similar to the cold wall hydrogen leak observed during SSME #2 ignition for STS-44 (E-5, 16, 20).

Fore-and-aft movement of the Orbiter base heat shield in the centerline area between the SSME cluster occurred during engine start-up. The motion was similar to that observed on previous launches (E-76, 77).

A ribbon-shaped (approximately 12"x1") debris object originated from the joint between the raised deck and the inclined deck ramp and appeared to be pulled into the SSME exhaust hole by aspiration (E-12).

At least three thin, dark pieces of debris, similar in appearance to scale off the MLP deck, entered the field-of-view from above and landed on the MLP deck west of the LH2 TSM without contacting the vehicle (E-3).

SSME ignition vibration/acoustics caused the loss of tile surface coating material from five places on the base heat shield (E-17, 18, 20) and two places on the RH RCS stinger (E-19).

SSME ignition caused numerous pieces of ice/frost to fall from the ET/Orbiter umbilicals. There were no unusual vapors or cryogenic drips from the ET/ORB umbilicals during tanking, stable replenish, ignition, or liftoff (OTV 009, 050, 054, 063, 064).

SSME ignition caused pieces of ice to shake loose from the LO2 feedline bellows and support brackets. The ice fell past the RH wing, but no contact was visible (OTV 054). Liftoff vibration caused approximately 12 pieces of ice/frost to shake loose from the LO2 feedline forward bellows and support bracket. Several more pieces of ice fell aft from the same area before the vehicle cleared the tower (E-5, 6, 54). Ice in the bellows and support bracket is an accepted condition per the NSTS-08303 criteria (E-65A).

A metal parts tag, approximately 1.5"x0.75", originated from the aft edge of the LO2 T-0 umbilical interface plate and fell aft past SSME #3 without contacting flight hardware (E-17, frame 2600; E-19, frames 3170-3350).

A red, flexible object, approximately 8"x2" and similar to red vinyl tape, fell out of the LO2 TSM door opening below the ECS ducts and was drawn into the SSME plume by aspiration (E-17, frames 2820-2940; E-19, frames 3403-3517).

The Orbiter LH2 and LO2 T-0 umbilicals disconnected and retracted properly (OTV 049, 063). Separation and disconnect of the GUCP from the External Tank was nominal (OTV 004). The GH2 vent line retracted and latched normally with no rebound. Some slack in the static retract lanyard caused the cable to contact the edge of the platform, rebound upward, and contact the right GUCP leg (E-41, 42, 48, 50).

A stud hang-up occurred on HDP #1. The stud remained fully extended until clear of the aft skirt foot, twanged briefly, and then dropped into the holddown post. One piece of ordnance debris (frangible nut web) dropped out of the DCS/stud hole and fell into the HDP haunch area. No contact with flight hardware was observed (E-9). No ordnance debris fell from any of the other HDP DCS/stud holes.

SRB thermal curtain tape was loose near HDP #4 prior to liftoff (E-1, 7, 15, 25).

Light frost was present in the ET GOX vent louvers. There was no TPS damage to the ET nose cone acreage, footprint, or fairing (OTV 013, 060, 061). ET "twang" was typical (E-79).

Water vapor/condensate trailed from the split rudder speed brake drain hole after liftoff (E-34, 212).

Ice continued to fall aft from the ET/ORB umbilicals as the vehicle cleared the tower. One piece impacted the body flap half way between the hinge and the trailing edge, but no tile damage was visible (E-52).

Numerous white flashes occurred in the SSME plume during ascent (E-54, 213).

ET/ORB umbilical purge barrier (baggie) fell aft shortly after the roll maneuver (E-213, 222).

Clusters of particles falling aft of the Orbiter after completion of the roll maneuver were traced to the forward RCS thrusters and were pieces of RCS paper covers. Other pieces of RCS paper covers were visible passing over the Orbiter wings (E-213, 222).

Frost melting and/or subliming on the -Z side of the External Tank during ascent was visible as vapor trailing aft of the vehicle (E-223, 224).

Debris entering the SSME plume during ascent caused orange flashes (E-212, 213, 222).

Movement of the body flap was similar to previous flights (E-207, 212).

Exhaust plume recirculation, SRB plume tailoff, and separation appeared nominal (E-207, 208, 223). Normal plume brightening and puffs of dark smoke occurred in the SRB plume prior to separation. Slag particles dropped out of the SRB plume before and after separation (TV-13).

Frustum separation from the forward skirts and parachute deployment appeared normal. Nozzle severance debris was typical.

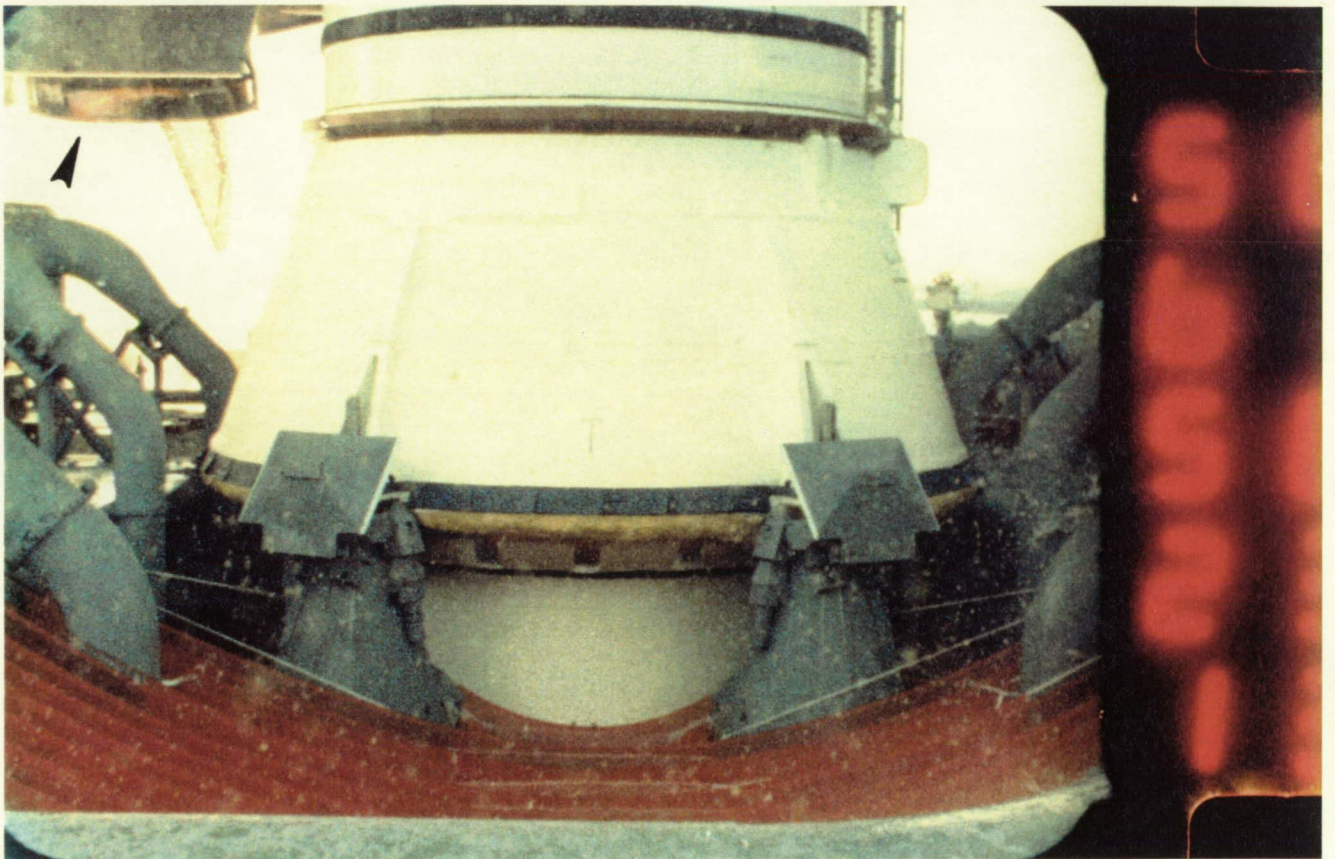
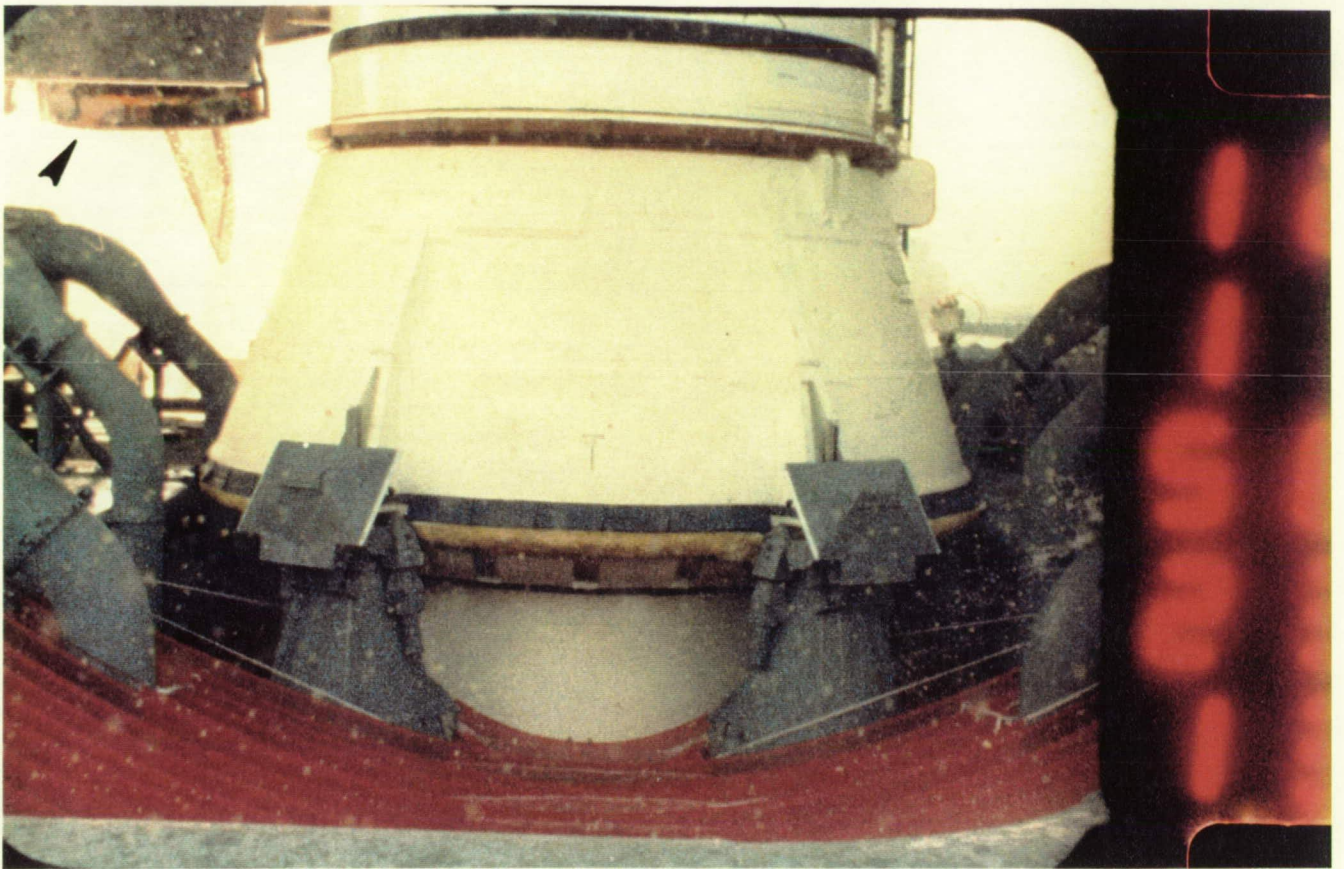

Orange vapor (burning hydrogen) was visible between the exit plane and the #9 hatband near the steer horn, or the coolant manifold, on the SSME #2 nozzle -Z side. This event may be indicative of a cold wall hydrogen leak.

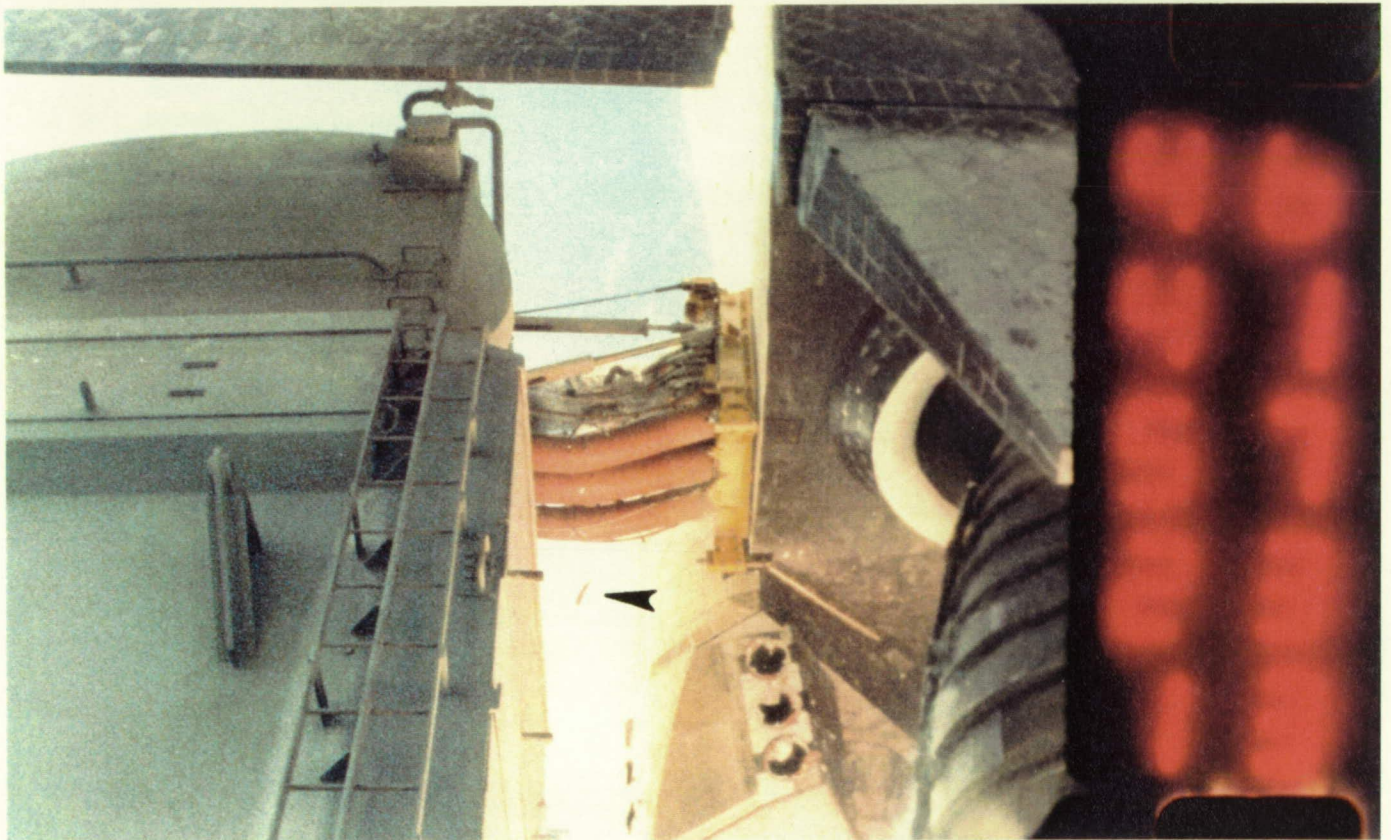
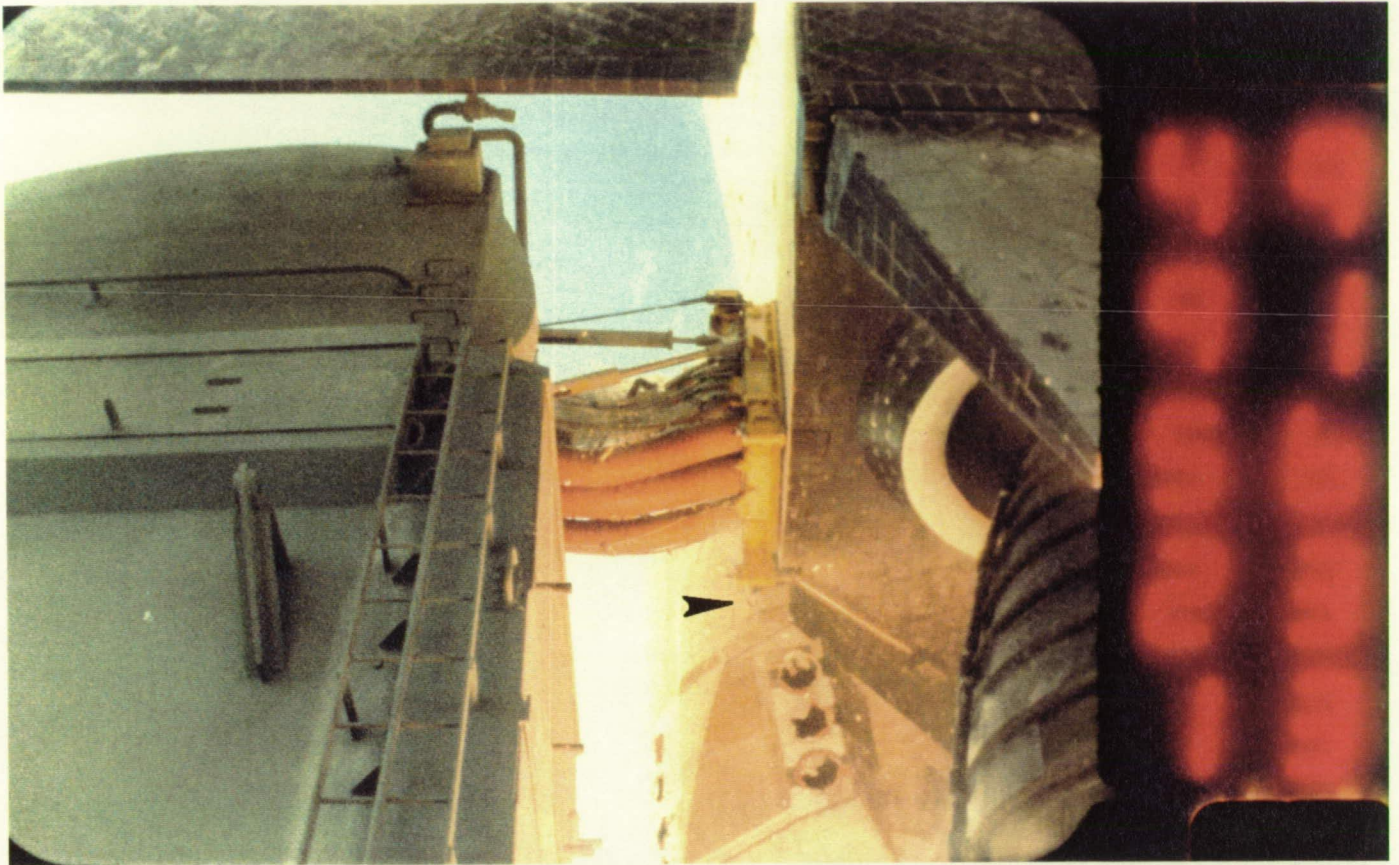

A 1.5" x 0.75" metal parts tag and a red, flexible object similar to vinyl tape fell aft past SSME #3 without contacting flight hardware.

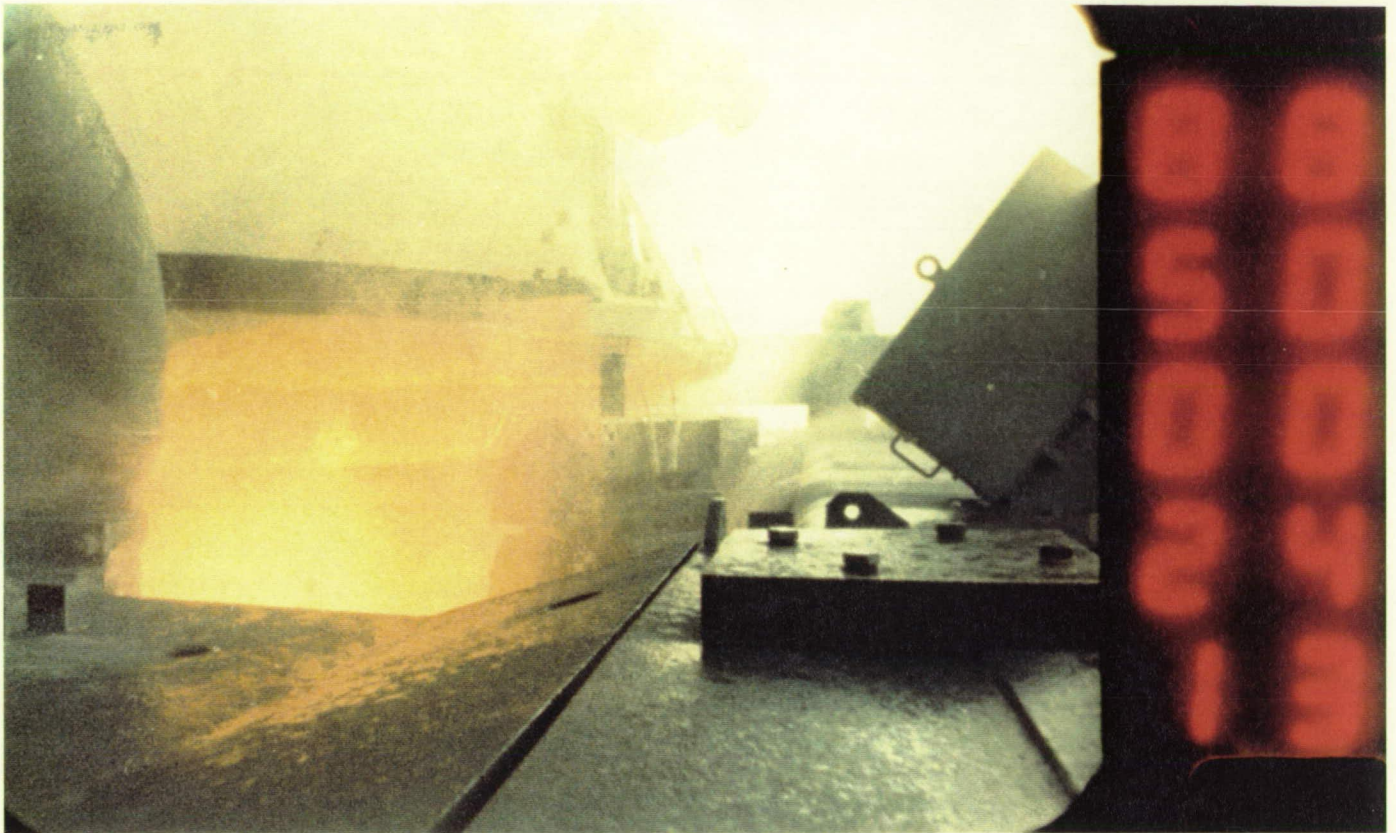

A stud hang-up occurred on HDP #1. One piece of ordnance debris fell from the DCS/stud hole into the HDP haunch area and may have been a frangible nut web.

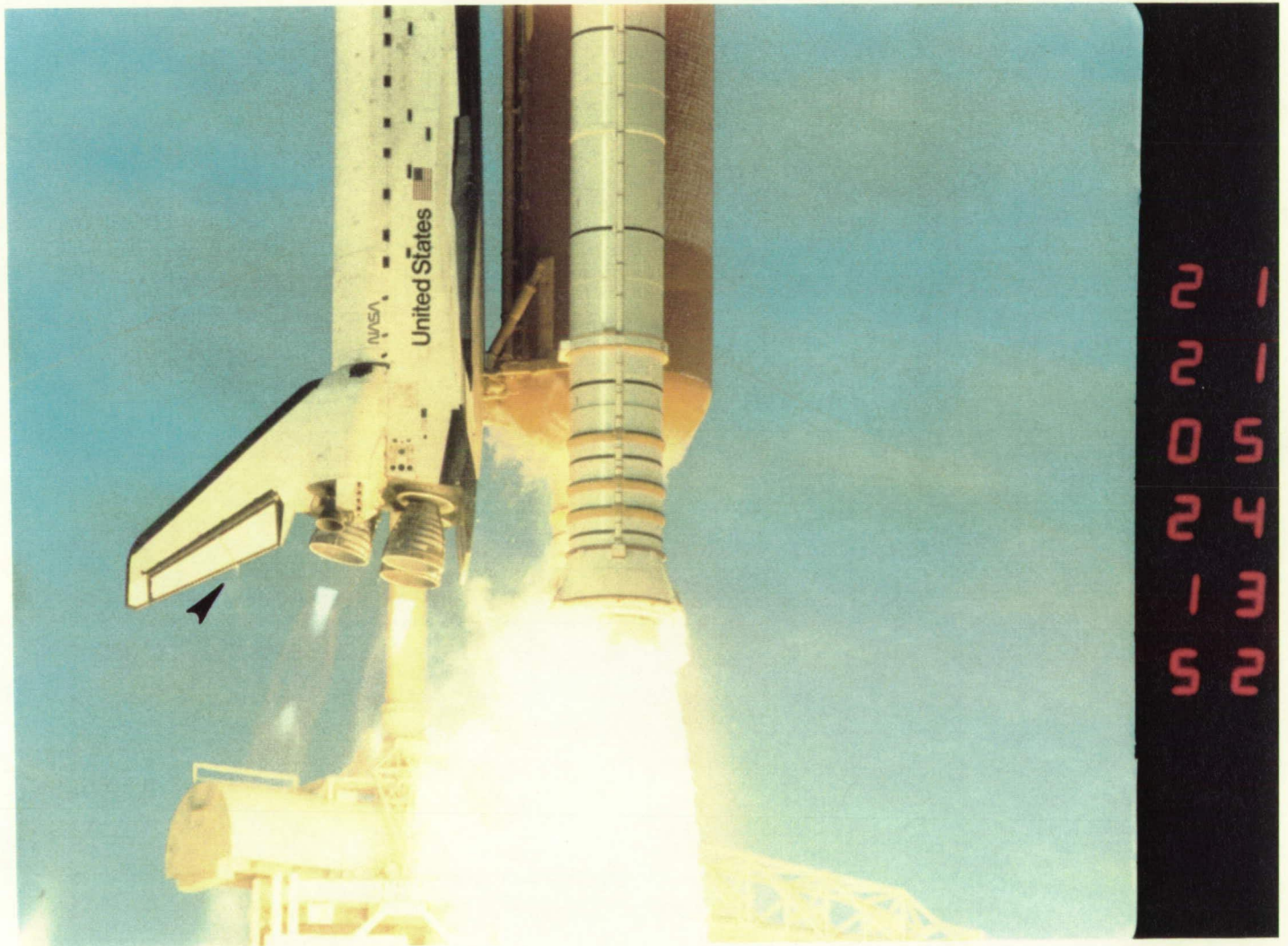

Water vapor/condensate trailed from the split rudder
speed brake drain hole after liftoff

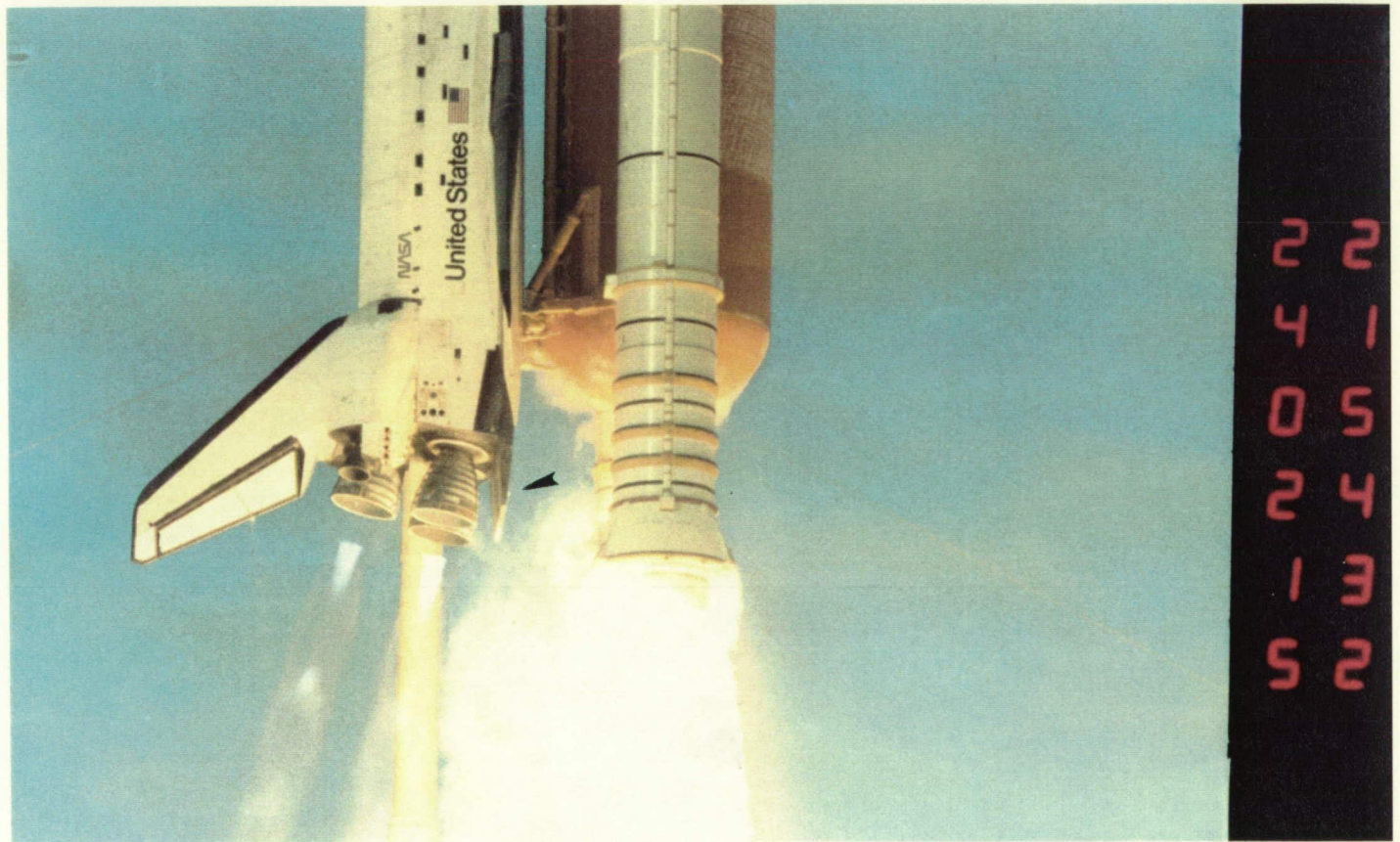
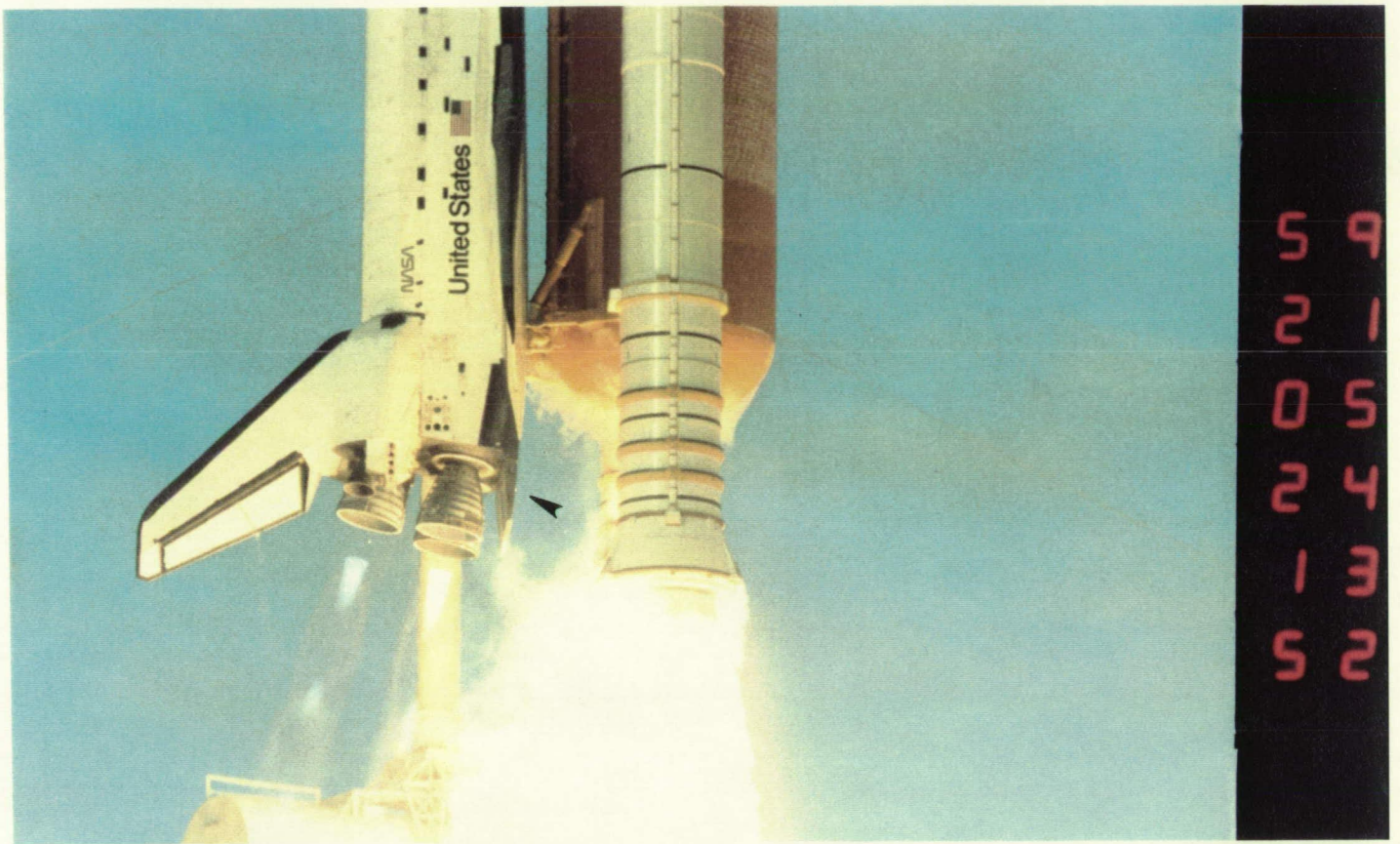

Ice continued to fall aft from the ET/ORB umbilicals as the vehicle cleared the tower. One piece impacted the Orbiter body flap (arrows), but no tile damage was visible.

5.2 ON-ORBIT FILM AND VIDEO SUMMARY

DTO-0312 was performed by the flight crew using hand held cameras. Seventy-two 35mm still photographs (36 with a 300 mm lens; 36 with a 600mm lens) were obtained of the ET after separation from the Orbiter. OV-103 was not equipped to carry umbilical cameras.

No major vehicle damage or lost flight hardware was observed that would have been a safety of flight concern.

ET structural separation from the Orbiter appeared nominal. The BSM burn scars on the LO2 tank were typical. No anomalies were observed on the nosecone, LO2 tank acreage, PAL ramps, LH2 tank, and aft hardpoint closeout. Four large and two small divots were visible in the aft dome spray abort. Plume recirculation and aft dome heating caused the usual charring of the NCFI.

Three divots occurred in the LH2 tank-to-intertank flange closeout (+Y+Z quadrant). One divot was visible in the -Y+Z quadrant flange closeout.

Residual hydrogen was venting from the LH2 ET/ORB umbilical - a phenomenon that has been observed on previous tanks.



ET structural separation from the Orbiter appeared nominal. No anomalies were observed on the nosecone, L02 tank acreage, and LH2 tank TPS acreage. Four divots were present in the LH2 tank-to-intertank flange closeout.

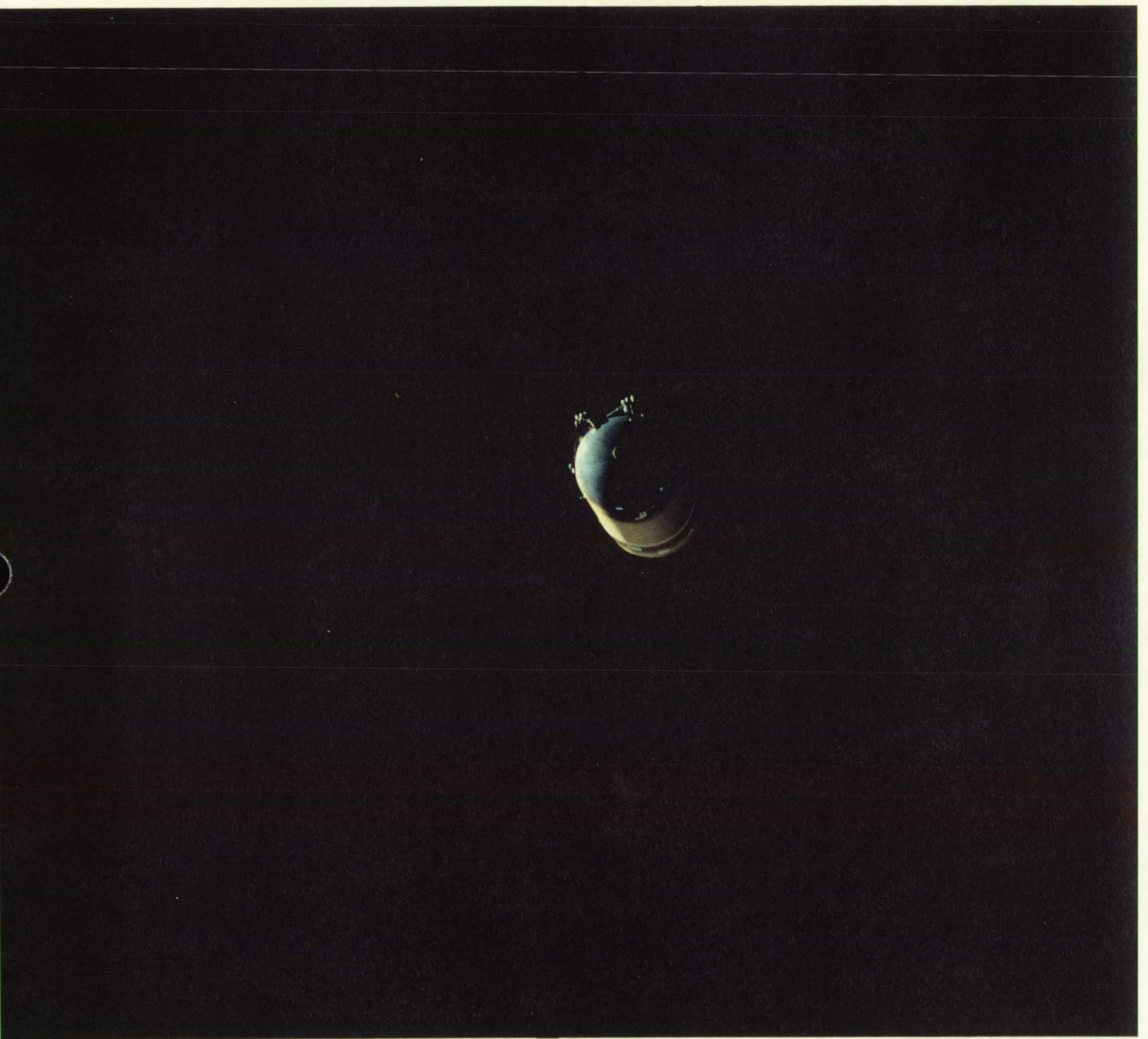

Four large and two small divots occurred in the aft dome spray abort. Plume recirculation and aft dome heating caused the usual charring of the NCFI. Residual hydrogen was venting from the LH2 ET/ORB umbilical - a phenomenon that has been observed on previous tanks.

5.3 LANDING FILM AND VIDEO SUMMARY

A total of 20 film and video data items, which included five videos, thirteen 16mm high speed films, and two 35mm large format films, were reviewed.

Orbiter performance in the Heading Alignment Circle (HAC) and final approach appeared nominal. The landing gear extended properly. Left and right main landing gear touchdown was almost simultaneous with the right side contacting the runway first.

The drag chute was deployed just after breakover, but before the nose gear contacted the runway. Drag chute deployment appeared nominal. A slight crosswind caused the drag chute to move left of the Orbiter centerline. The chute risers appeared to contact tiles on the vertical stabilizer stinger.

Touchdown of the nose landing gear was smooth. There were no anomalies during rollout. No tile damage was visible.

6.0 SRB POST FLIGHT/RETRIEVAL DEBRIS ASSESSMENT

Both Solid Rocket Boosters were inspected for debris damage and debris sources at CCAFS Hangar AF on 5 December 1992 from 0830 to 1130 hours. From a debris standpoint, both SRB's were in excellent condition.

6.1 RH SOLID ROCKET BOOSTER DEBRIS INSPECTION

The RH frustum had 16 MSA-2 debonds and one 1-inch diameter area of missing TPS between the +Y and -Z axes at the 381 ring frame (Figure 4). Minor localized blistering of the Hypalon paint had occurred along the 395 ring. All BSM aero heatshield covers were locked in the fully opened position.

The RH forward skirt exhibited no debonds or missing TPS. Both RSS antennae covers/phenolic base plates were intact. Minor blistering of the Hypalon paint occurred on the systems tunnel cover and around the ET/SRB attach point (Figure 5). No pins were missing from the frustum severance ring. The forward separation bolt and electrical cables appeared to have separated cleanly.

The Field Joint Protection System (FJPS) closeouts were generally in good condition. Minor trailing edge damage to the FJPS and the GEI cork runs were attributed to debris resulting from severance of the nozzle extension.

Separation of the aft ET/SRB struts appeared normal. The ET/SRB aft struts, ETA ring, IEA, and IEA covers appeared undamaged. The upper strut fairing was missing a 7" x 3" area of K5NA and the substrate was charred. All three aft booster stiffener rings also appeared undamaged. The aft booster stiffener ring splice plate closeouts were intact and no K5NA material was missing.

The phenolic material on the kick ring was delaminated. The K5NA closeouts (protective domes) on the kick ring forward and aft fasteners had been eliminated. RTV-133 replaced the K5NA over the forward fasteners. One divot, measuring 4 inches in diameter, had occurred over fasteners on the aft skirt TPS near HDP #3.

The HDP #1 stud hole was broached due to a stud hang-up. A 10"x3" area of EPON shim was missing from HDP #3 (Figure 6). The material was lost prior to water impact (sooted/charred substrate). All Debris Containment System (DCS) plungers were seated properly.

Figure 4. RIGHT SRB FRUSTUM

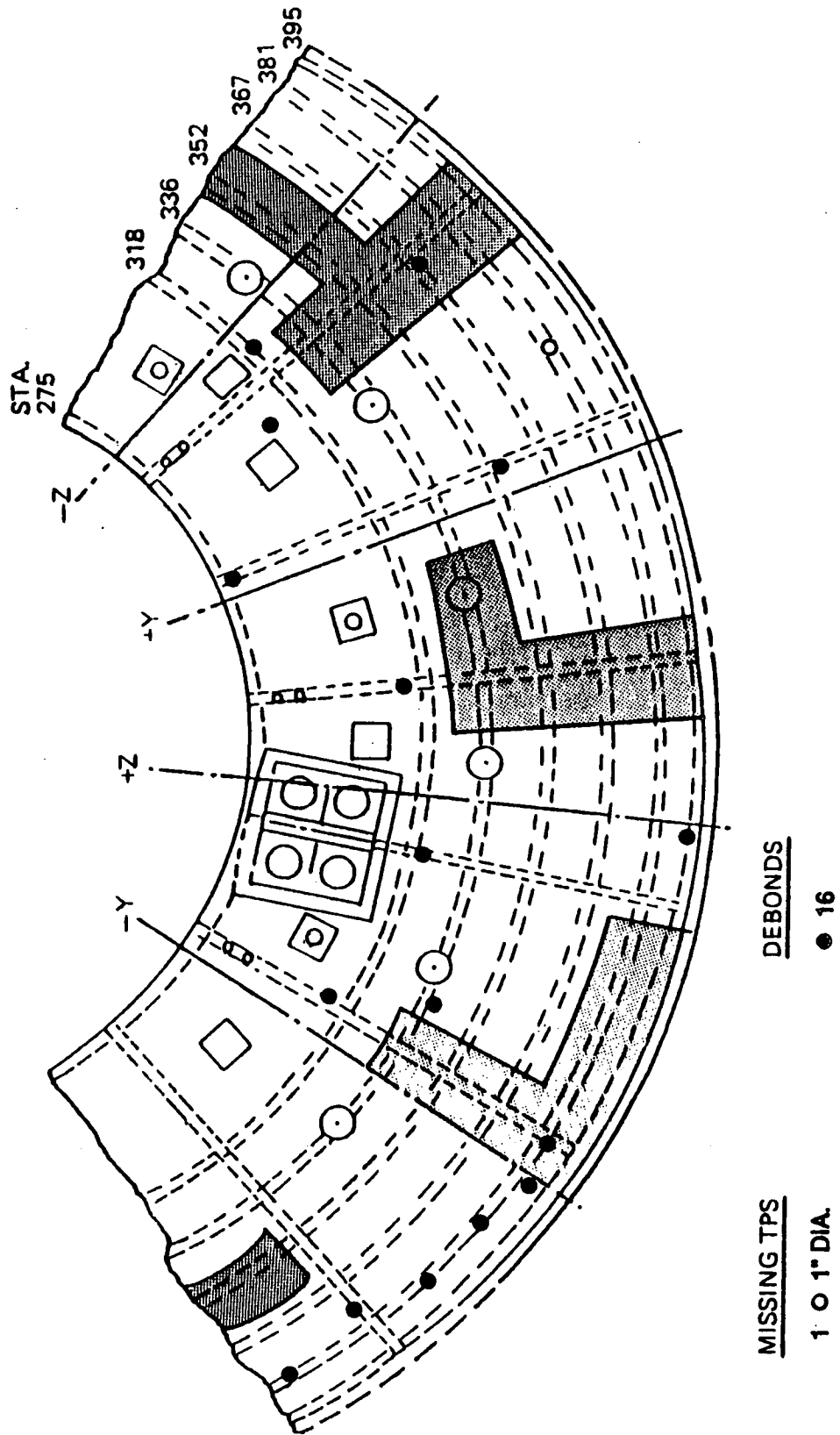
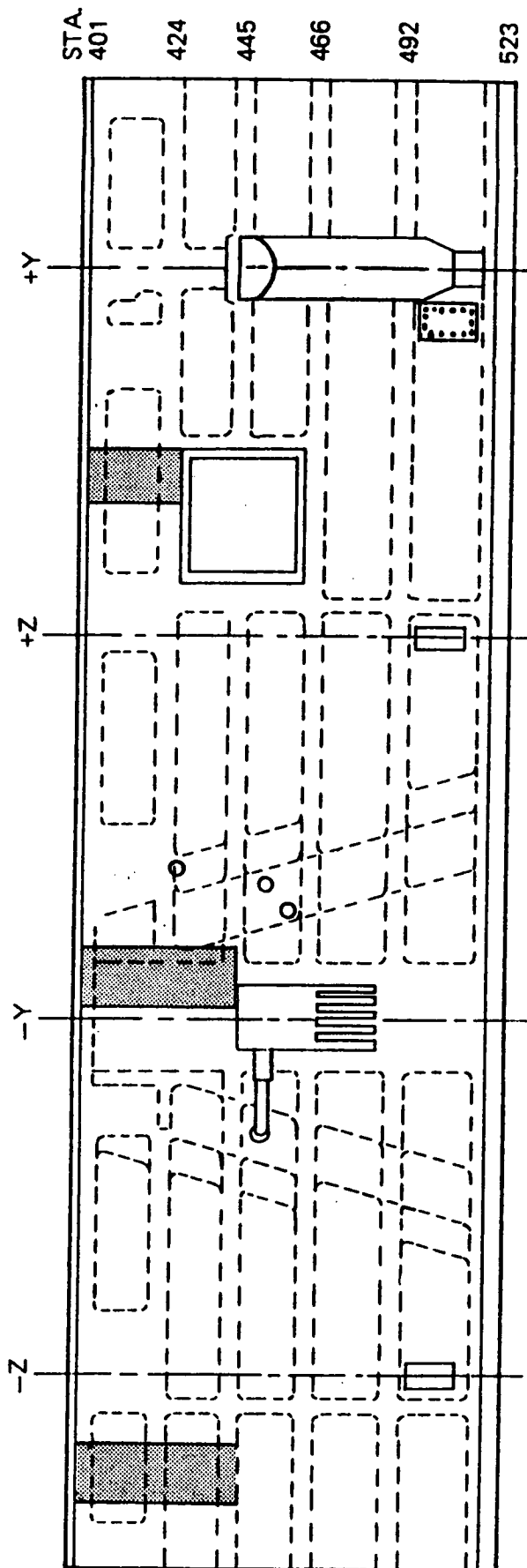

Figure 5. RIGHT SRB FWD SKIRT



TPS MISSING
O (HANDLING)

DEBONDS
NONE

MINOR BLISTERING OF
HYPALON PAINT ON SYSTEMS
TUNNEL COVER AND AROUND
ET/SRB ATTACH POINT

Figure 6. RIGHT SRB AFT SKIRT EXTERIOR TPS

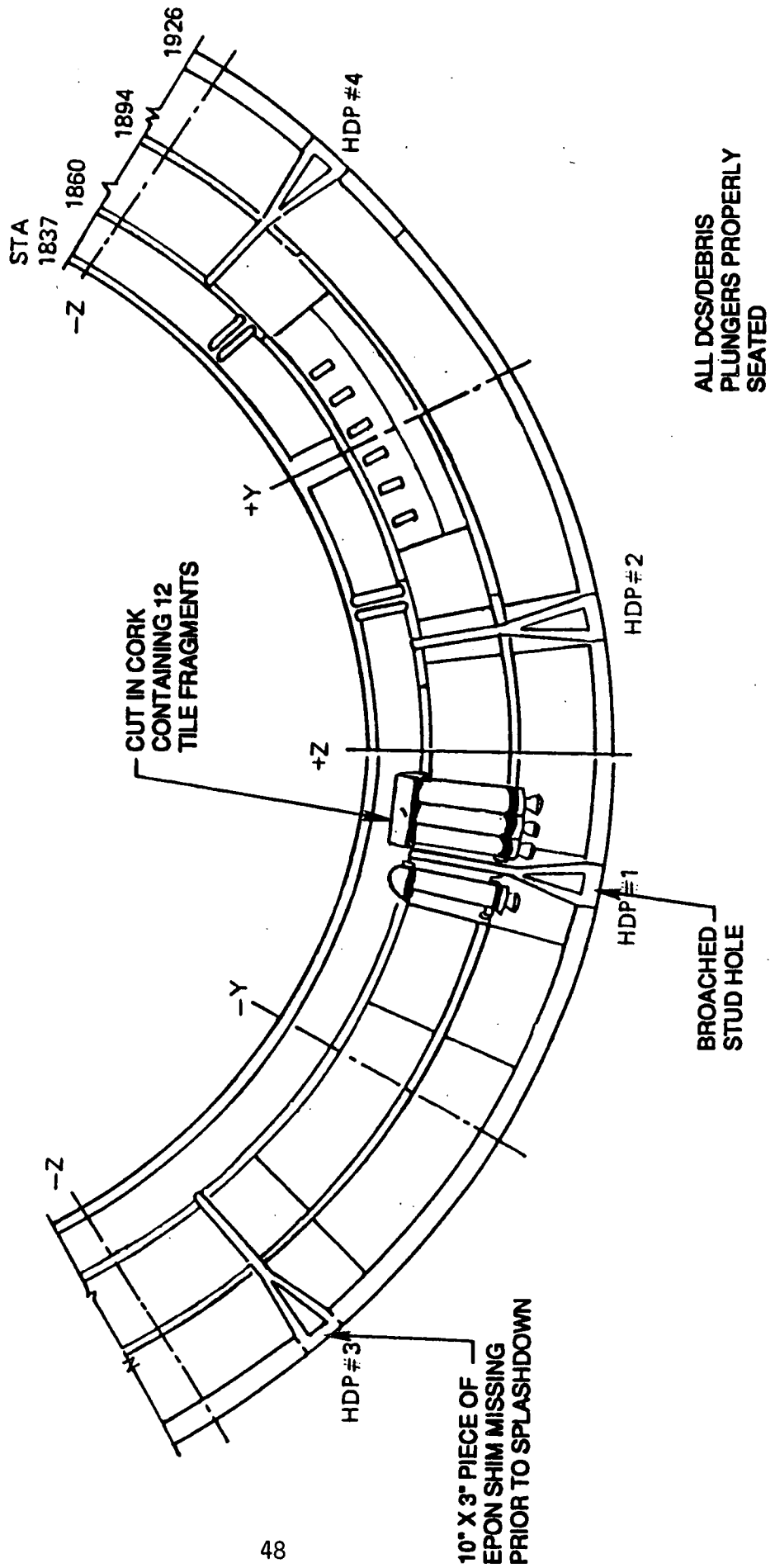

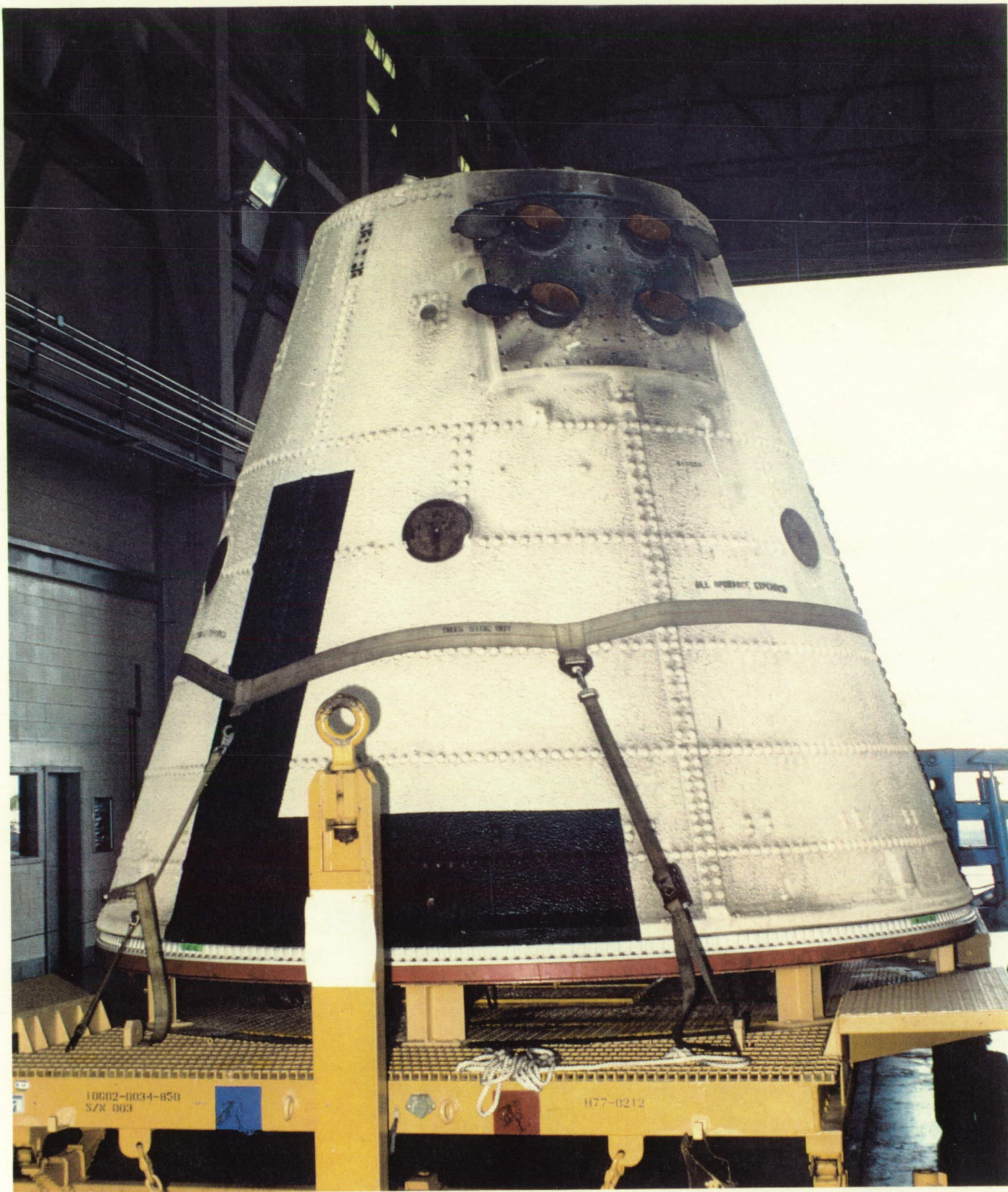

The RH frustum had 16 MSA-2 debonds over fasteners and one 1-inch diameter area of missing TPS between the +Y and -Z axes at the 381 ring frame. All BSM aero heat shield covers were locked in the fully opened position.

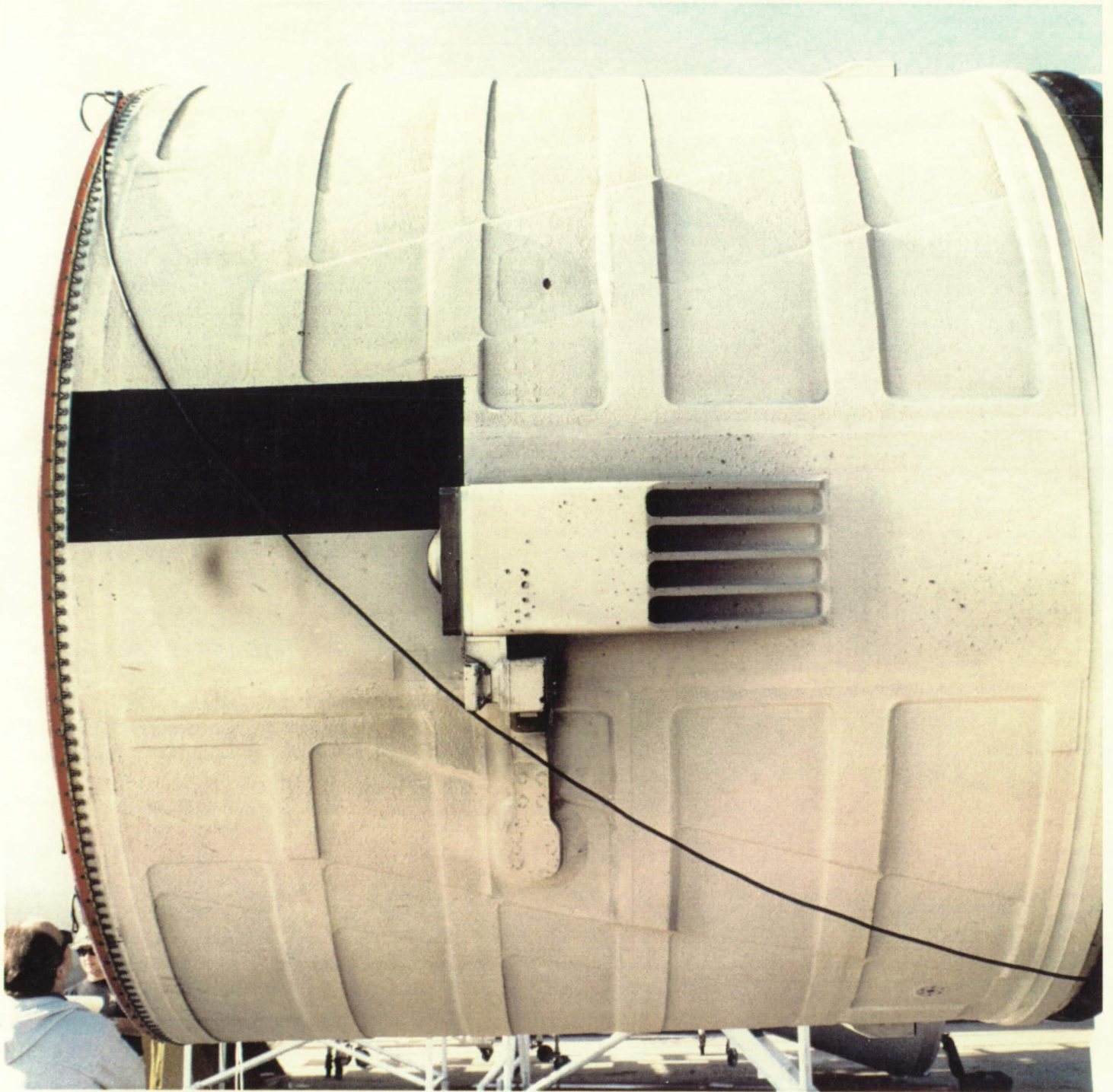

The RH forward skirt exhibited no debonds or missing TPS. Minor blistering of the Hypalon paint occurred on the forward ET/SRB attach point. Both RSS antenna covers/TPS were intact and undamaged.

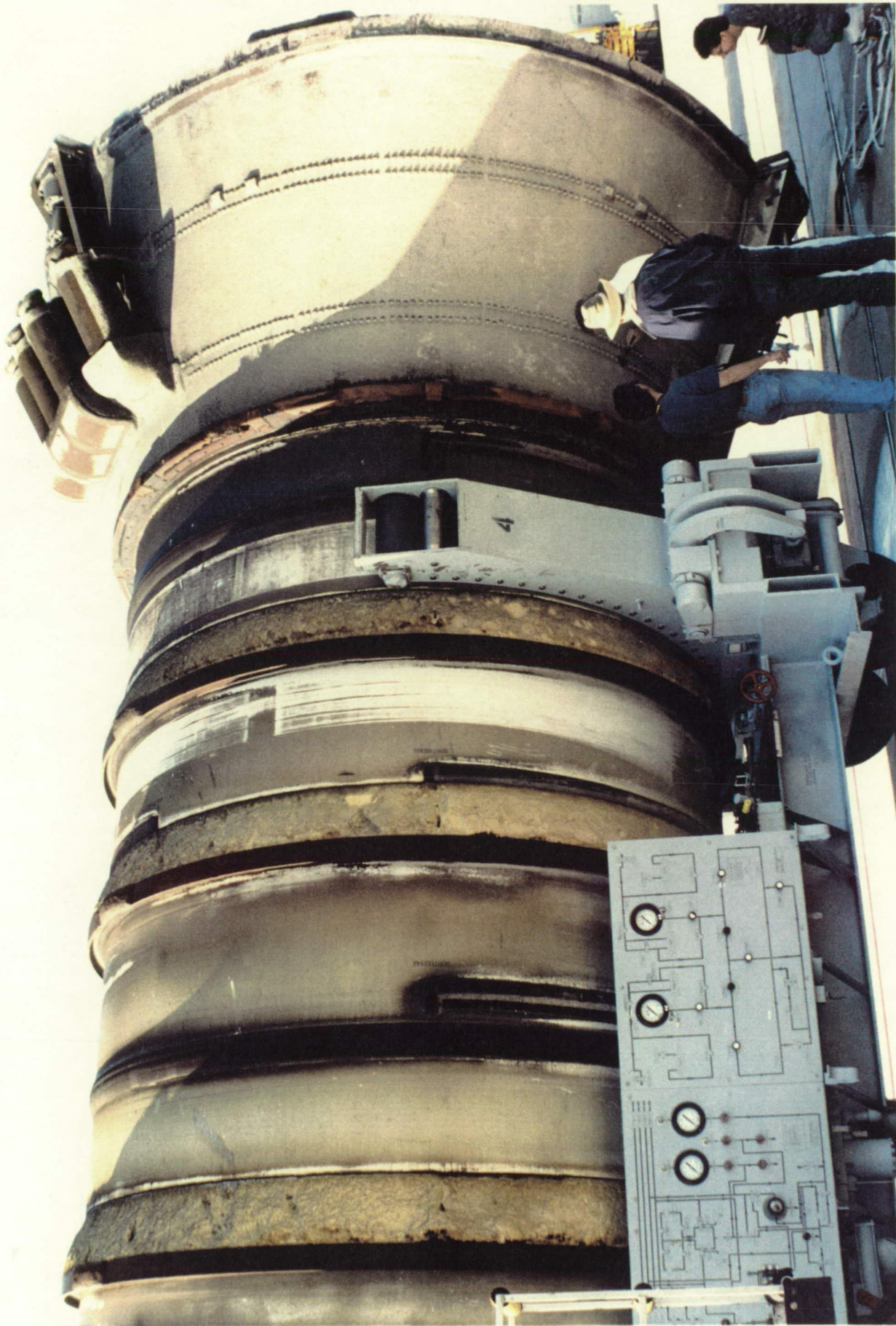

Post flight condition of the RH aft booster. Separation of the aft ET/SRB struts appeared normal. One divot, measuring 4 inches in diameter, had occurred over fasteners on the aft skirt TPS near holddown post #3.

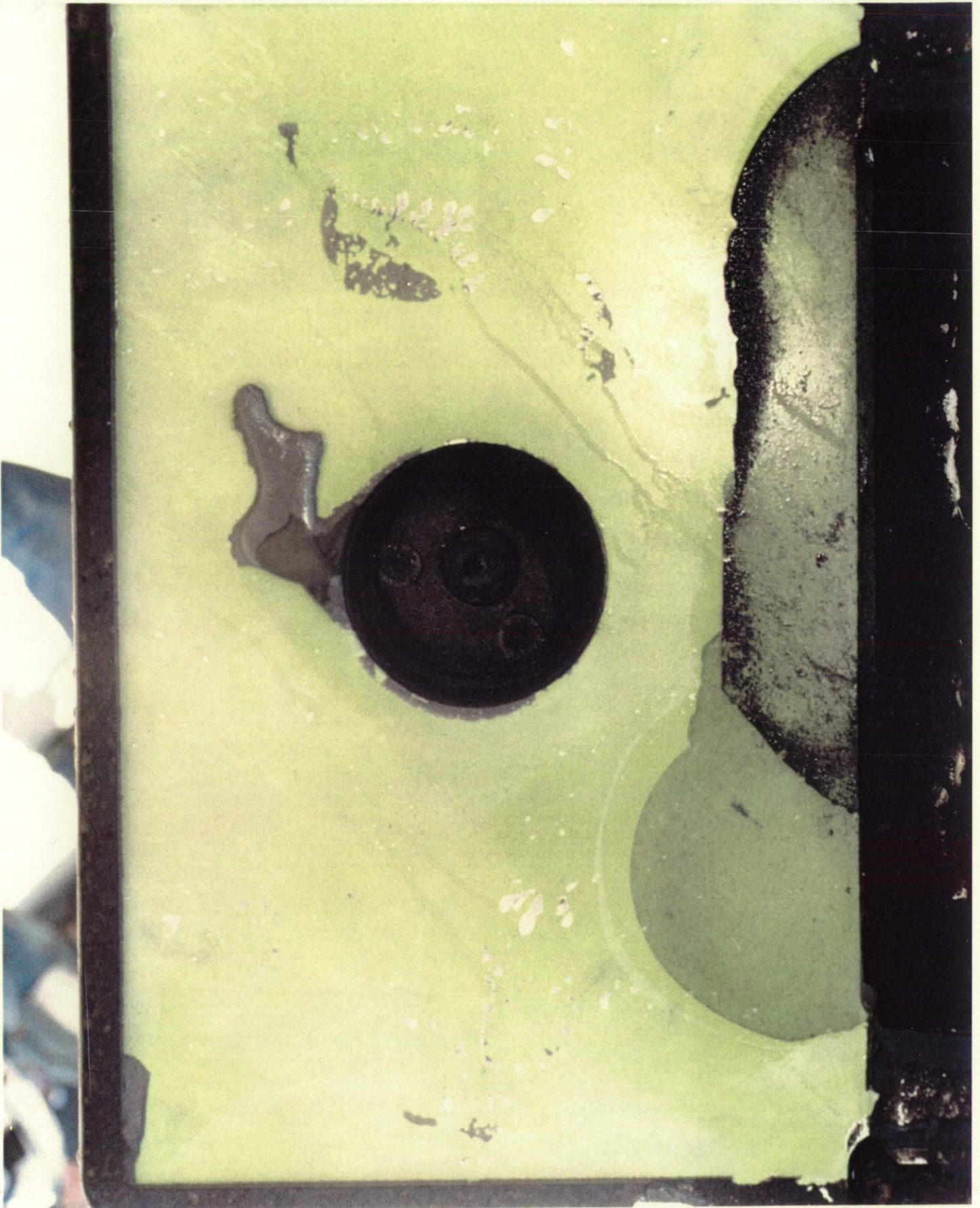

A 10"x3" area of EPON shim was missing from HDP #3. The material was lost prior to water impact (sooted substrate).

6.2 LH SOLID ROCKET BOOSTER DEBRIS INSPECTION

The LH frustum had 28 MSA-2 debonds over fasteners. Torn and missing MSA-2 (1-inch diameter) from one location between the +Y and +Z axes just aft of the 336 ring frame may have been the result of handling damage (Figure 7). There was minor localized blistering of the Hypalon paint. The BSM aero heat shield covers were locked in the fully opened position, though three of the four cover attach rings had been bent by parachute riser entanglement.

The LH forward skirt exhibited no debonds or missing TPS. The phenolic plates on both RSS antennae were intact, but delaminated. The forward separation bolt and electrical cables appeared to have separated cleanly. Three pins were missing from the frustum severance ring, a condition that reportedly was the result of parachute entanglement (Figure 8). Minor blistering of the Hypalon paint occurred near the ET/SRB attach point and on the systems tunnel cover.

The Field Joint Protection System (FJPS) closeouts were in good condition. In general, minor trailing edge damage to the FJPS and the GEI cork runs were attributed to debris resulting from severance of the nozzle extension.

Separation of the aft ET/SRB struts appeared normal. The ET/SRB aft struts, ETA ring, IEA, and IEA covers appeared undamaged. The upper strut fairing was missing two areas of K5NA (5" x 3" and 4" x 1") along the separation edge. The substrate was charred. Two aft booster stiffener rings sustained water impact damage. The stiffener ring splice plate closeouts were intact and no K5NA material was missing.

The phenolic material on the kick ring was delaminated in only localized areas. The K5NA closeouts (protective domes) on the kick ring forward and aft fasteners had been eliminated. RTV-133 replaced the K5NA over the forward fasteners.

All four Debris Containment System (DCS) plungers were properly seated, though a frangible nut web was caught between the DCS debris plunger and the stud hole wall. The small K5NA repair on the inside of the HDP #5 foot, which was applied 24 hours prior to launch, was intact. None of the EPON shim material was lost prior to water impact (Figure 9).

Figure 7. LEFT SRB FRUSTRUM

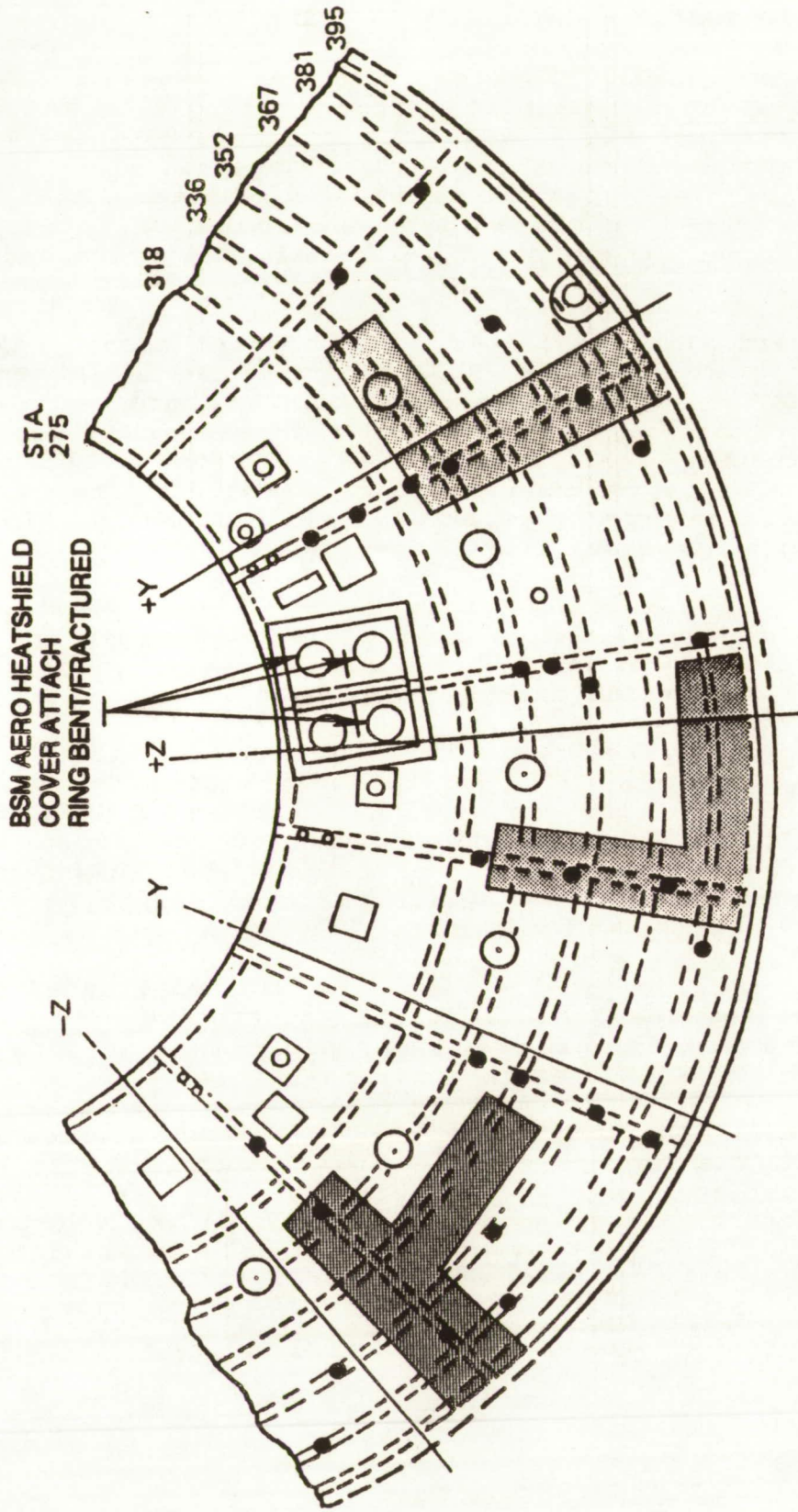

MISSING TPS
1 0 ~ 1 SQ. IN

DEBONDS
28 ●

Figure 8.

LEFT SRB FWD SKIRT

3 FRUSTUM SEVERANCE
RING PINS MISSING

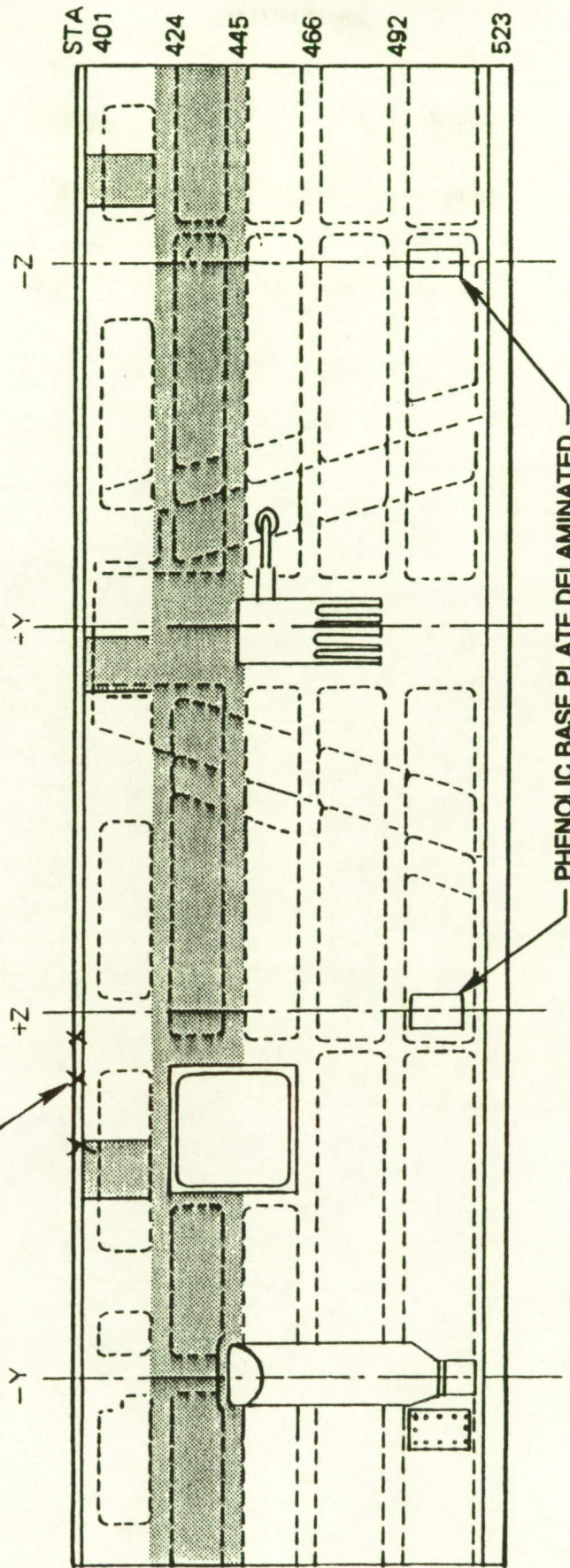

TPS MISSING
NONE

DEBONDS
NONE

MINOR BLISTERING OF
HYPALON PAINT ON SYSTEMS
TUNNEL COVER AND AROUND
ET/SRB FITTING

Figure 9. LEFT SRB AFT SKIRT EXTERIOR TPS

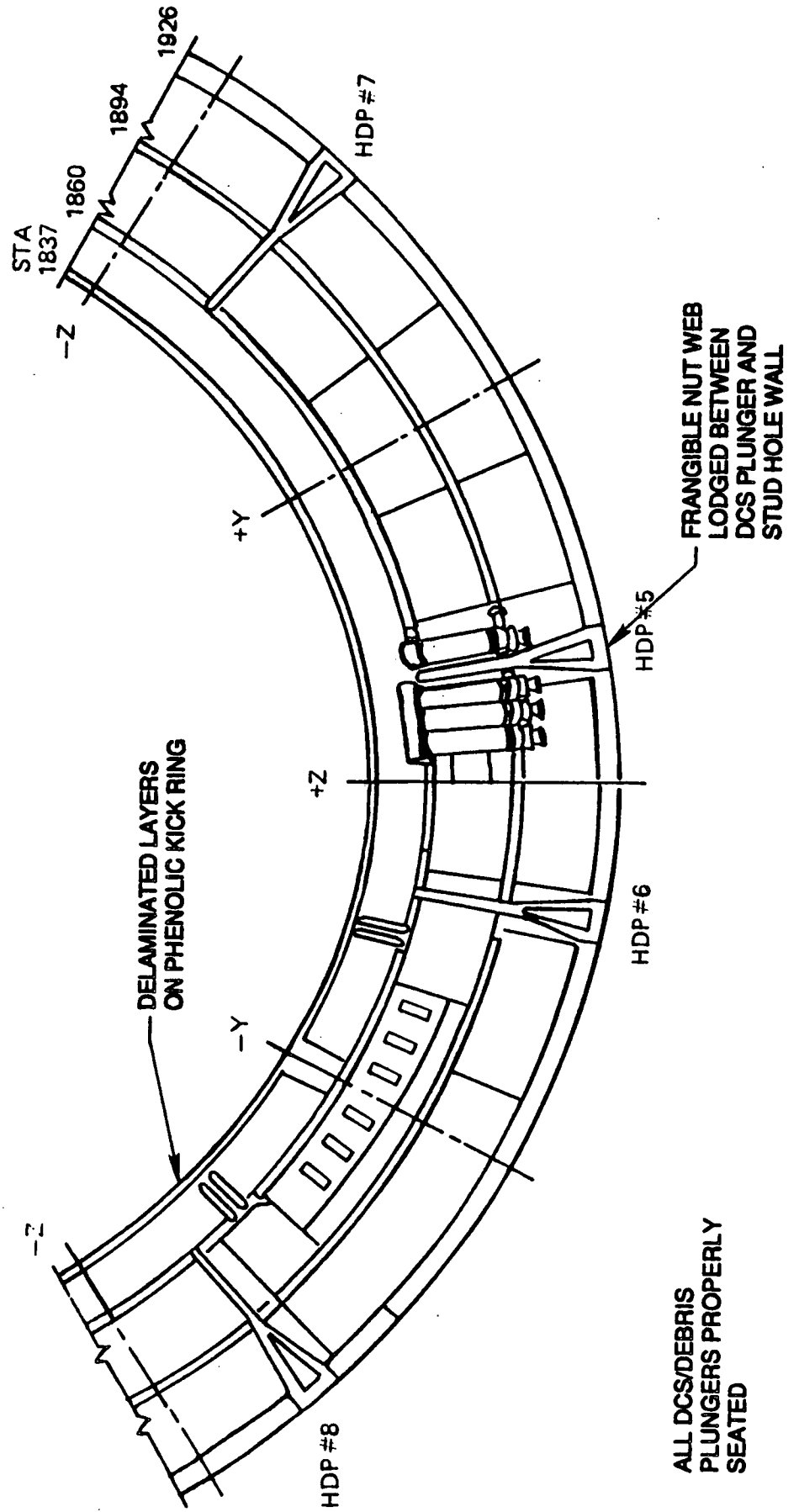

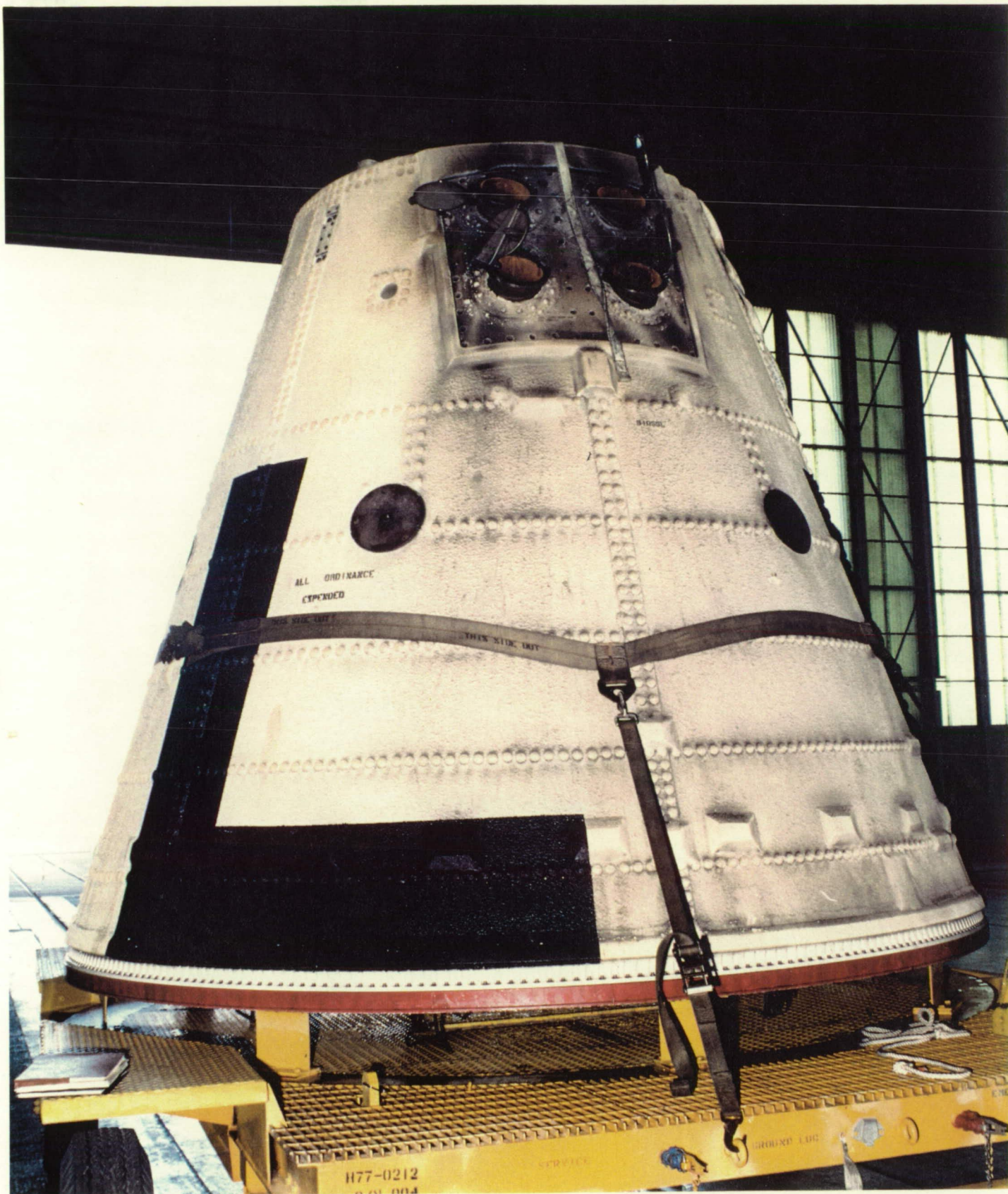

The LH frustum had 28 MSA-2 debonds over fasteners. The BSM aero heat shield covers were locked in the fully opened position, though three of the four cover attach rings had been bent by parachute riser entanglement.

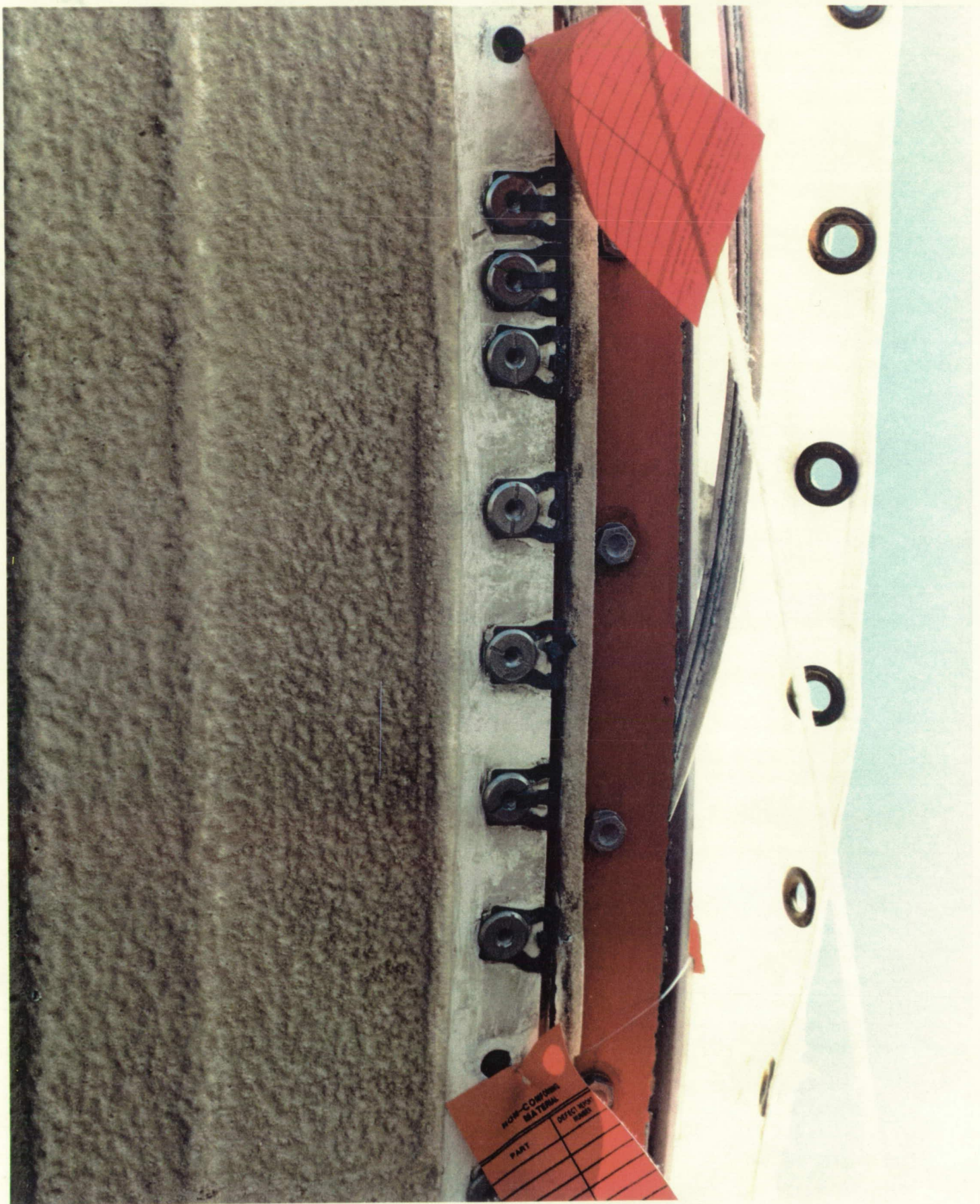

Three pins were missing from the frustum severance ring, a condition that reportedly was the result of parachute entanglement

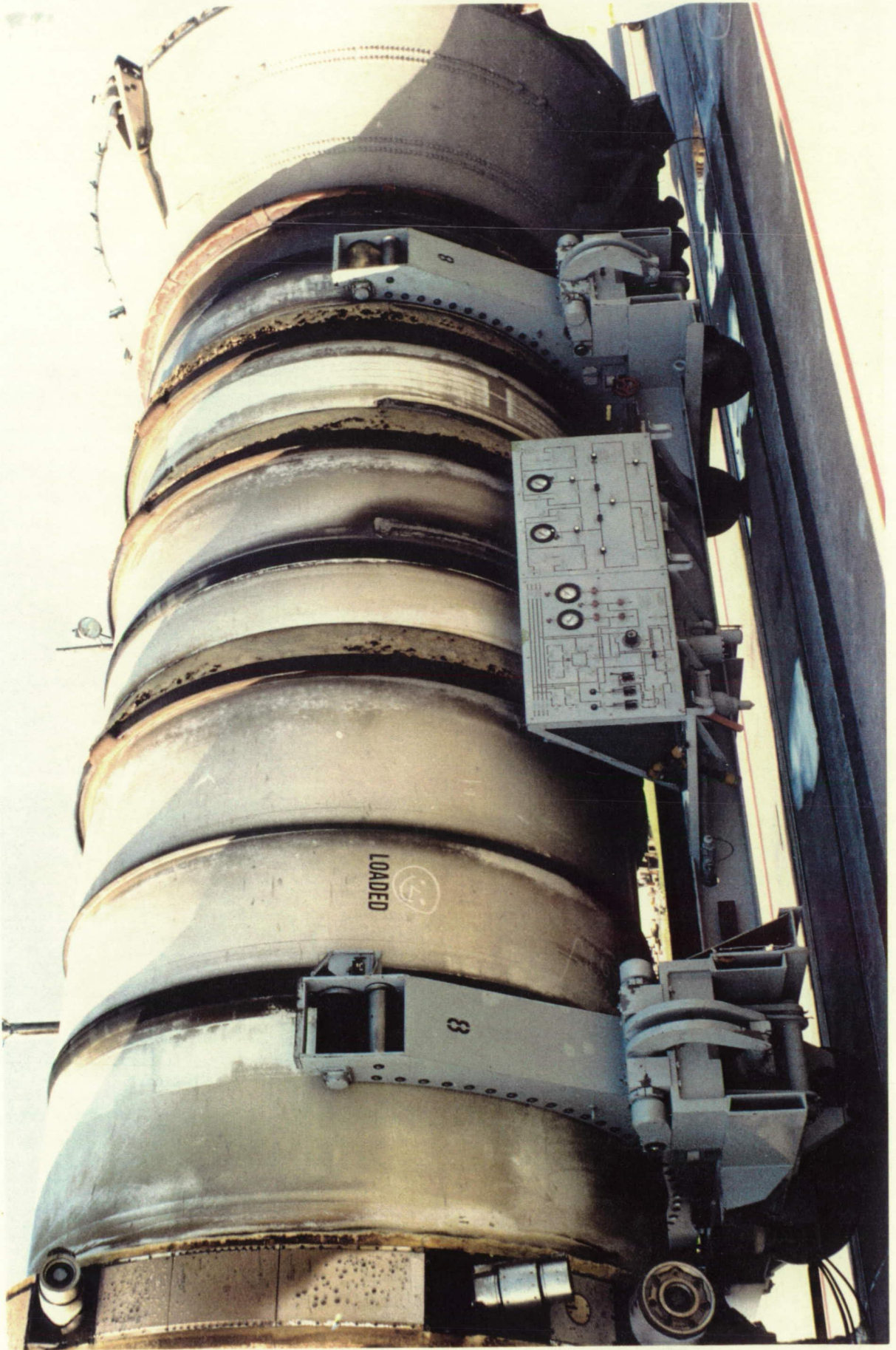

Post flight condition of the LH aft booster. The ET/SRB aft struts, ETA ring, IEA, and IEA covers appeared undamaged. Two aft booster stiffener rings sustained water impact damage.



Separation of the aft ET/SRB struts appeared normal. The upper strut fairing was missing two areas of K5NA (5"x3" and 4"x1") along the separation edge. The substrate was charred/sooted.

6.3 RECOVERED SRB DISASSEMBLY FINDINGS

Post flight disassembly of the Debris Containment System (DCS) housings revealed an overall system retention of 99 percent and individual holddown post retention percentages as listed:

HDP #	% of Nut without 2 large halves	% of Ordnance fragments	% Overall
1	99	94	99
2	99	96	99
3	93	96	94
4	99	97	99
5	99	93	99
6	99	99	99
7	99	96	99
8	99	93	99

STS-53 was the twelfth flight to utilize the new "optimized" frangible links in the holddown post DCS's. The link was designed to increase the DCS plunger velocity and improve the seating alignment while leaving the stud ejection velocity the same. The design was intended to prevent ordnance debris from falling out of the DCS yet not increase the likelihood of a stud hang-up. According to NSTS-07700, the Debris Containment System should retain a minimum of 90 percent of the ordnance debris.

USBI Squawk 53-005 documented a 2.75 inch long (mild radius) by 0.125 inch wide fracture in the RH SRB aft skirt center BSM mounting base cover TPS. The fracture/incision occurred at an angle of approximately 30 degrees to the SRB centerline and extended through the 0.5 inch thick cork closeout to the substrate. Soot deposits, erosion, heat effects, and discoloration were visible around the damage site. Twelve black and white particles, or flakes, were subsequently discovered inside the fracture/incision. Laboratory analysis determined the particles and flakes were high in silica content and are believed to be pieces of Orbiter lower surface tile. The analysis (reference USBI Report M&P-3032-033-91 and DAC-103-92MP) concluded the aft skirt cork damage was most likely caused by an impact from ascent debris containing Orbiter tile material.

SRB Post Launch Anomalies are listed in Section 9.

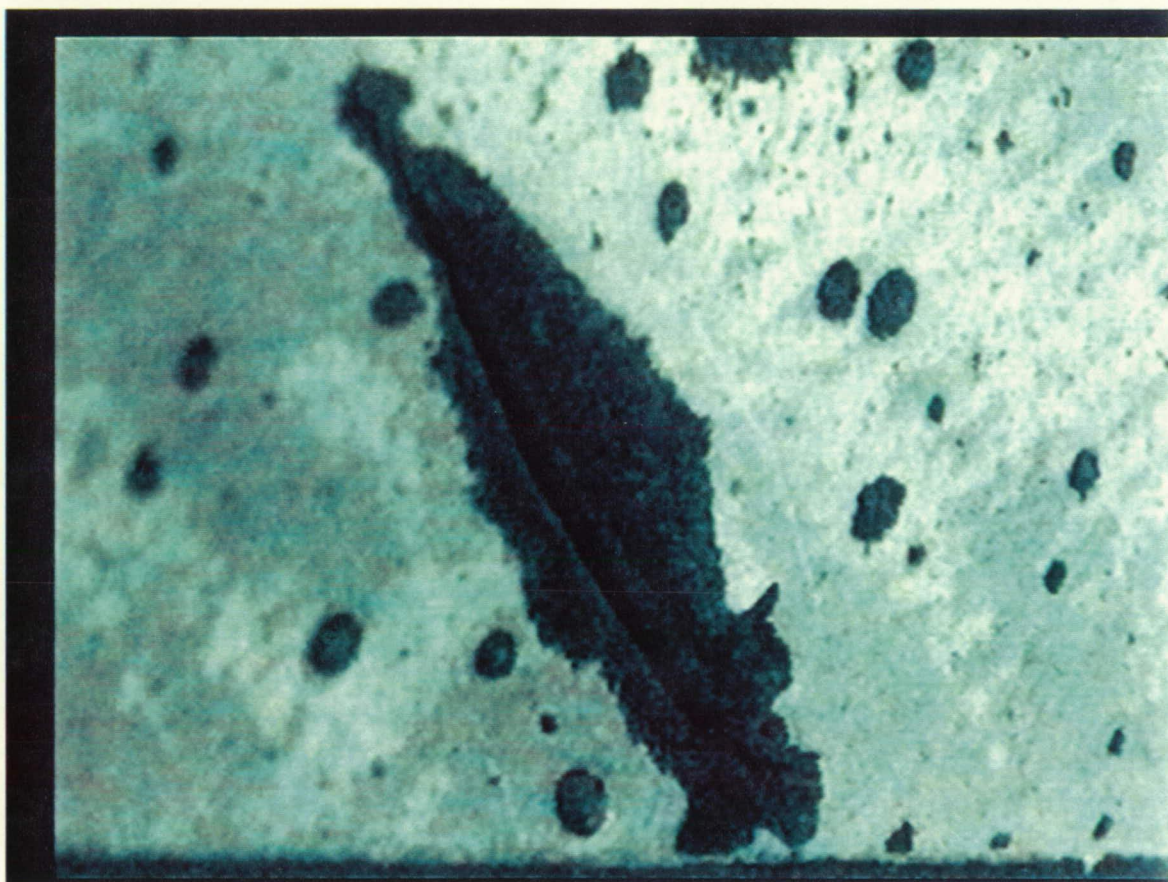

A fracture/incision in the cork insulation on the RH SRB aft center BSM fairing contained black and white particles believed to be fragments from Orbiter lower surface tiles. The cork damage was most likely caused by an impact from ascent debris containing Orbiter tile material.

7.0 ORBITER POST LANDING DEBRIS ASSESSMENT

A post landing debris inspection of OV-103 (Discovery) was conducted on December 9-11, 1992, at the Ames-Dryden Flight Research Center (ADFRF) on Runway 22 and in the Mate/Demate Device (MDD). This inspection was performed to identify debris impact damage and, if possible, debris sources. The Orbiter TPS sustained a total of 240 hits, of which 23 had a major dimension of one inch or greater. This total does not include the numerous hits on the base heat shield attributed to SSME vibration/acoustics and exhaust plume recirculation. A comparison of these numbers to statistics from 36 previous missions of similar configuration (excluding missions STS-23, 24, 25, 26, 26R, 27R, 30R, and 42 which had damage from known debris sources), indicates that the total number of hits was greater than average while the number of hits one inch or larger was average. Figures 10-13 show the TPS debris damage assessment for STS-53.

The Orbiter lower surface sustained a total of 145 hits, of which 11 had a major dimension of one inch or greater. The majority of this damage occurred on the right side of the vehicle and is primarily attributed to ice from the LO2 feed line. A cluster of 56 hits, with 2 greater than one inch, was observed forward and outboard of the LO2 ET/Orbiter umbilical opening. Similar clusters have been observed on previous flights and are attributed to ice/debris impacts at ET separation.

The tile material which was found embedded in the right hand SRB aft skirt Booster Separation Motor (BSM) mounting base cover TPS may have originated from tile V070-391016-551 located on the Orbiter forward right hand lower surface. The 1.8 by 1.2 by 0.2 inch area of missing material from this tile includes some Original Equipment Manufacturer (OEM) tile identification markings (yellow-green dots). Tile coating material recovered from the BSM TPS was reported to exhibit OEM tile identification marking. No other missing tile material from the Orbiter forward lower surface included any OEM marking. Although there are no visible signs of any foreign material in the V070-391016-551 damage site, the size and shape of the damage is characteristic of an impact by a low density object, such as ET TPS foam. Samples of tile and adjacent gap filler material from this damage site and one other on the Orbiter forward right hand lower surface were taken by Rockwell TPS engineering for laboratory analysis at Downey (reference Figure 14 and Section 8.0).

STS-53

Figure 10. **DEBRIS DAMAGE LOCATIONS**

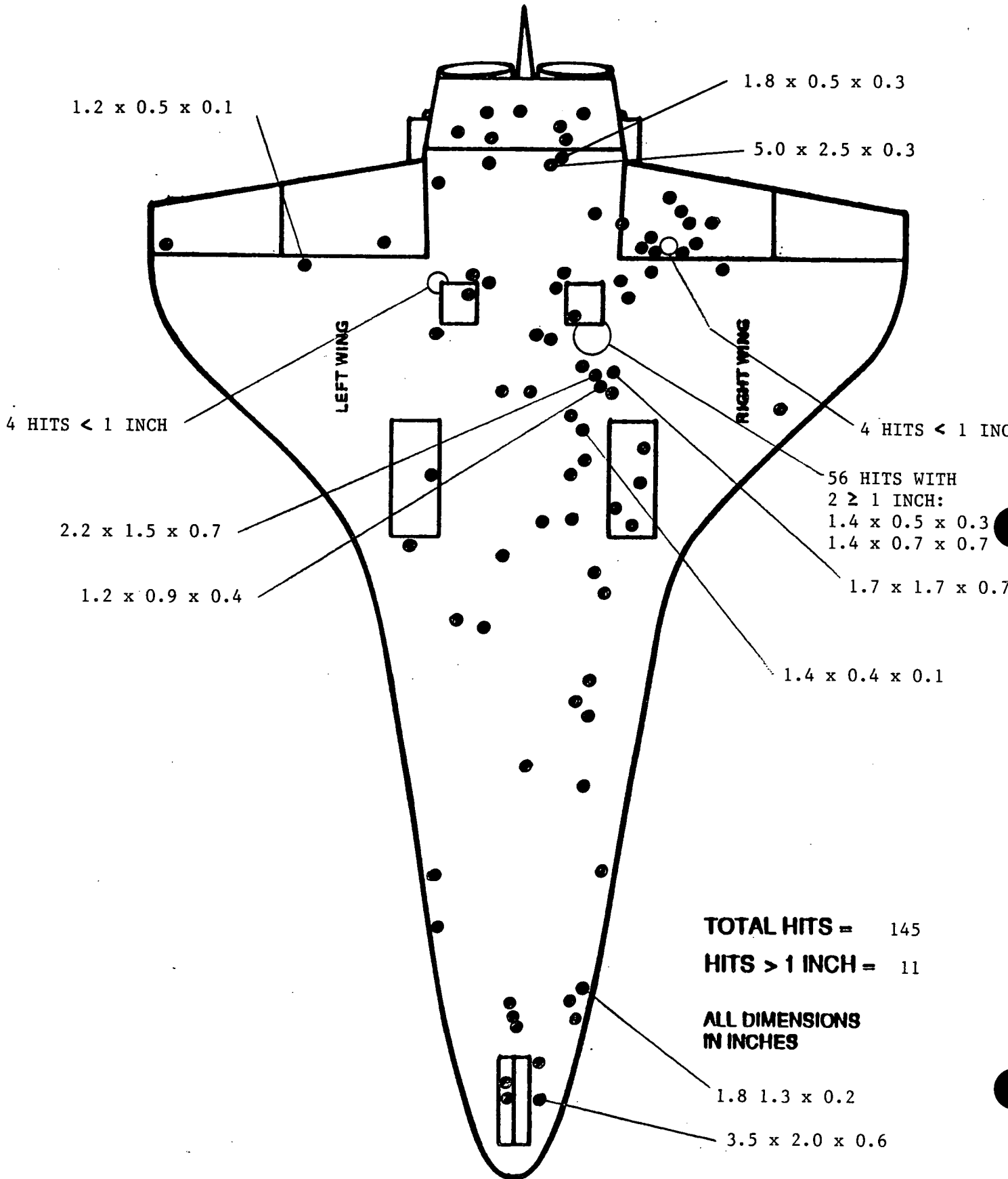

TOTAL HITS = 145
HITS > 1 INCH = 11
**ALL DIMENSIONS
IN INCHES**

STS-53

Figure 11. **DEBRIS DAMAGE LOCATIONS**

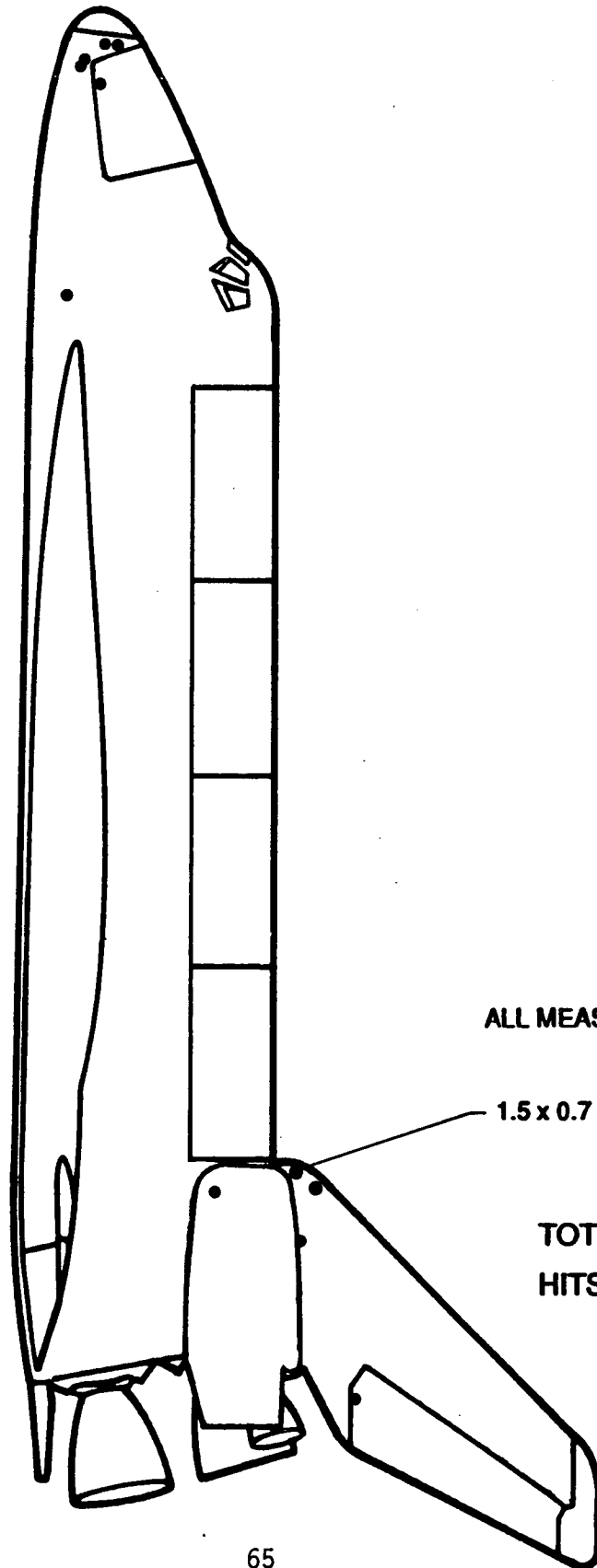

ALL MEASUREMENTS IN INCHES

1.5 x 0.7 x 0.1

TOTAL HITS = 12

HITS > 1 INCH = 1

STS-53

Figure 12. **DEBRIS DAMAGE LOCATIONS**

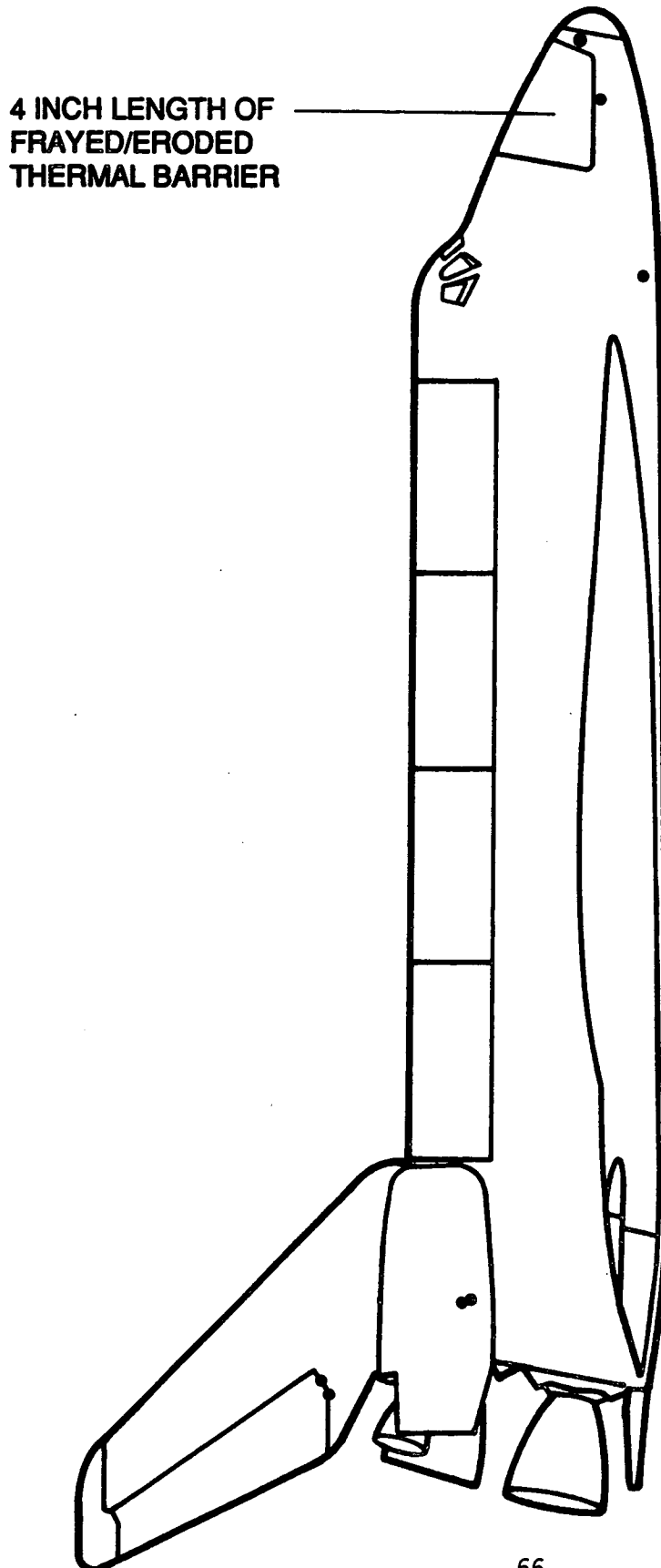

TOTAL HITS = 7
HITS > 1 INCH = 0

STS-53

Figure 13. DEBRIS DAMAGE LOCATIONS

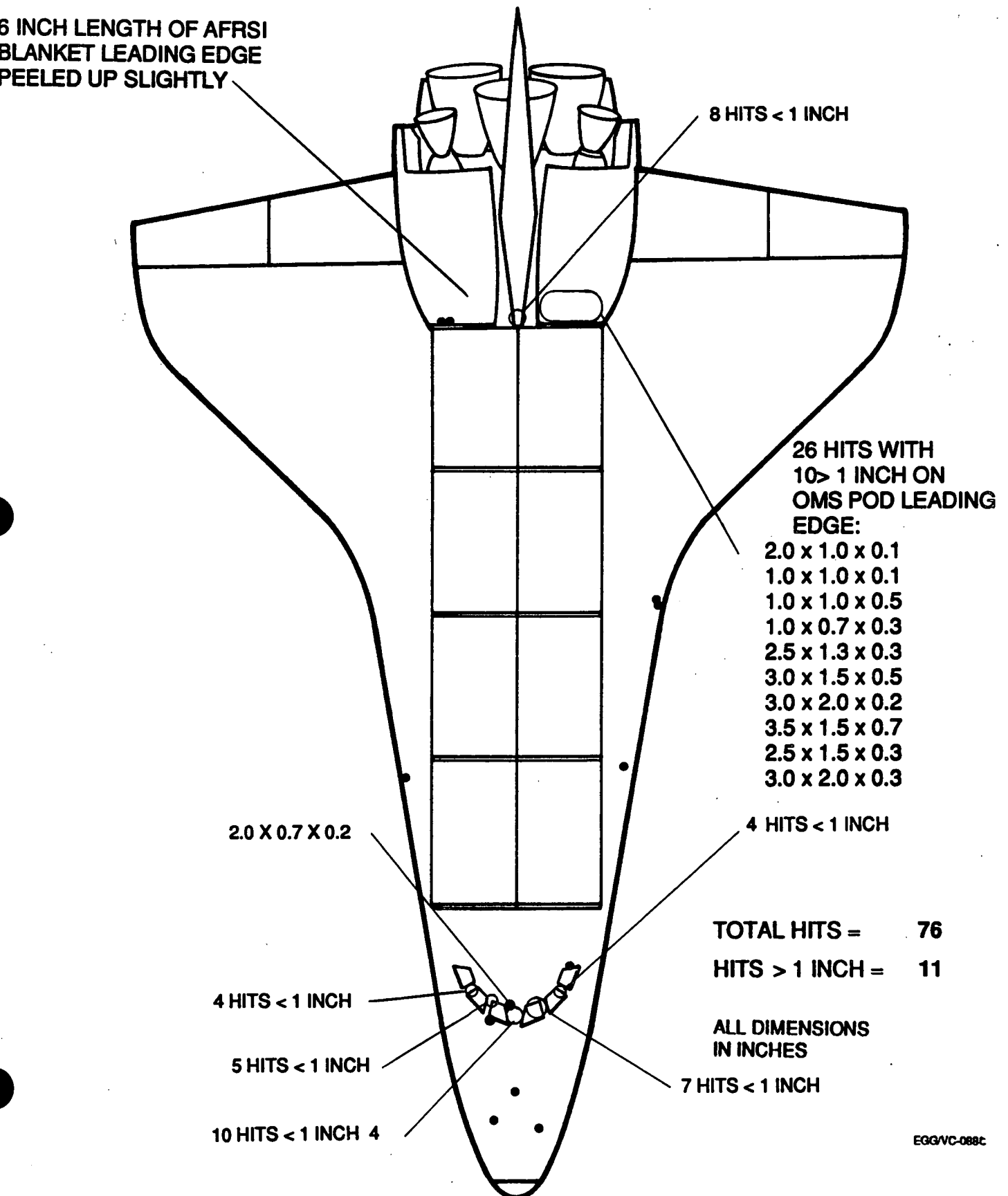

The following table breaks down the STS-53 Orbiter debris damage by area:

	<u>HITS > 1"</u>	<u>TOTAL HITS</u>
Lower surface	11	145
Upper surface	1	48
Right side	0	5
Left side	1	11
Right OMS Pod	0	4
Left OMS Pod	10	27
TOTALS	23	240

No TPS damage was attributed to material from the wheels, tires, or brakes. The main landing gear tires were considered to be in excellent condition for a landing on a concrete runway.

All three ET/Orbiter separation devices (EO-1, 2, and 3) appeared to have functioned properly. The stop-bolts on the EO-1 separation assembly did not sustain any damage/bending. All ET/Orbiter umbilical separation ordnance retention shutters were closed properly. No flight hardware was found on the runway below the umbilicals when the ET doors were opened.

The left wing Reinforced Carbon-Carbon (RCC) panel #9 exhibited a 4 by 2.5 inch area of coating bubbling and spalling. Left wing RCC panel #6, right wing RCC panel #13, and left wing RCC T-seals #8, 14, and 16 all exhibited smaller areas of coating bubbling and spalling.

Tile damage on the base heat shield was typical. Four Dome Mounted Heat Shield (DMHS) closeout blanket sacrificial panels were nearly detached from the 1:30 to 4:30 o'clock position of SSME #2 exposing the inner blanket layer. This layer was eroded/missing in a number of places revealing the underlying batting material. The outer layer of the SSME #1 DMHS splice at the 6 o'clock position exhibited minor fraying. All of the remaining DMHS blankets were in excellent condition.

Some blue-tinted discoloration was visible on the SSME #2 nozzle in the area where the cold wall fire was observed during post launch film review. Tiles on the trailing edge of the body flap immediately underneath SSME #2 were discolored (milky white). This discoloration may have been a result of the nozzle fire.

The tiles on the left OMS pod leading edge sustained more damage than usual. Access to this area was not available at Dryden, therefore the number of impact sites and dimensions shown in Figure 11 are approximate. The cause of this damage is still undetermined.

Orbiter windows #3 and #4 exhibited typical hazing and streaking. Only a very light haze was present on the other forward facing windows (#1, #2, #5, and #6). Surface wipes have been taken from windows #1 through #6 (and one other vehicle location as indicated in Figure 14) for laboratory analysis. A total of 33 hits with one greater than one inch were noted on the perimeter tiles around windows #1 through #6. Most all of these hits were small and shallow in depth and may have been caused by RTV used to bond paper covers to the FRCS nozzles, exhaust products from the SRB booster separation motors, ice/TPS debris from the External Tank LO2 tank, or Orbiter TPS fragments (or any combination of the above).

Runway 22 was inspected and swept by Air Force personnel on December 8, 1992 and all potentially damaging debris was removed. A post landing inspection of Runway 22 was performed immediately after landing. No unexpected flight hardware was found on the runway.

This flight marked the fifth use of the Orbiter drag chute. The drag chute appeared to have functioned nominally. All drag chute hardware was recovered and showed no signs of abnormal operation (reference Figure 15 for recovery locations). A tile on the lower (-Z) right hand edge of the drag chute compartment opening was slightly damaged by separation of the chute compartment door. Similar damage has been observed after every previous use of the drag chute. Two additional damage sites were observed on the vertical tail stinger, one on the lower surface and the other on the stinger trailing edge. This damage was most likely caused by contact with the chute riser lines during deployment.

A Minolta/Land Cyclops infrared spot radiometer was used to measure the surface temperatures on several areas of the Orbiter (per OMRSD V09AJ0.095). Two hours twenty-seven minutes after landing, the Orbiter nose cap RCC was 105 degrees Fahrenheit (F). Two hours twenty-seven minutes after landing, the right wing leading edge RCC panel #9 was 73 degrees F and panel #17 was 72 degrees F (reference Figure 16). These measurements were taken much later than usual due to an FRCS oxidizer leak.

In summary, the total number of STS-53 Orbiter TPS debris hits was greater than average while the number of hits one inch or larger was average when compared to previous missions (reference Figure 17-19).

Orbiter Post Launch Anomalies are listed in Section 9.

STS-53

Figure 14. **CHEMICAL SAMPLE LOCATIONS**

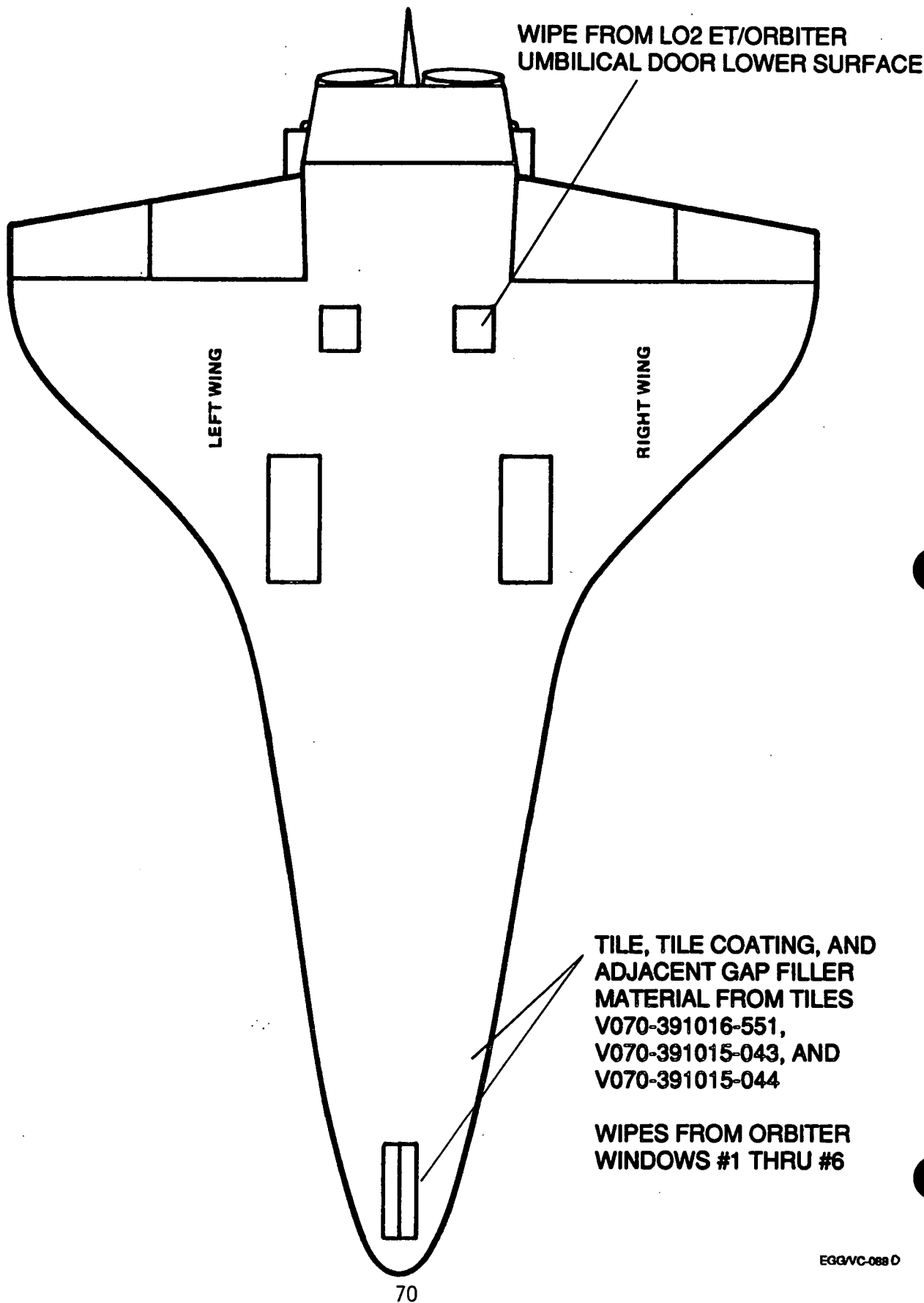

STS-53

Figure 16. TEMPERATURE MEASUREMENTS

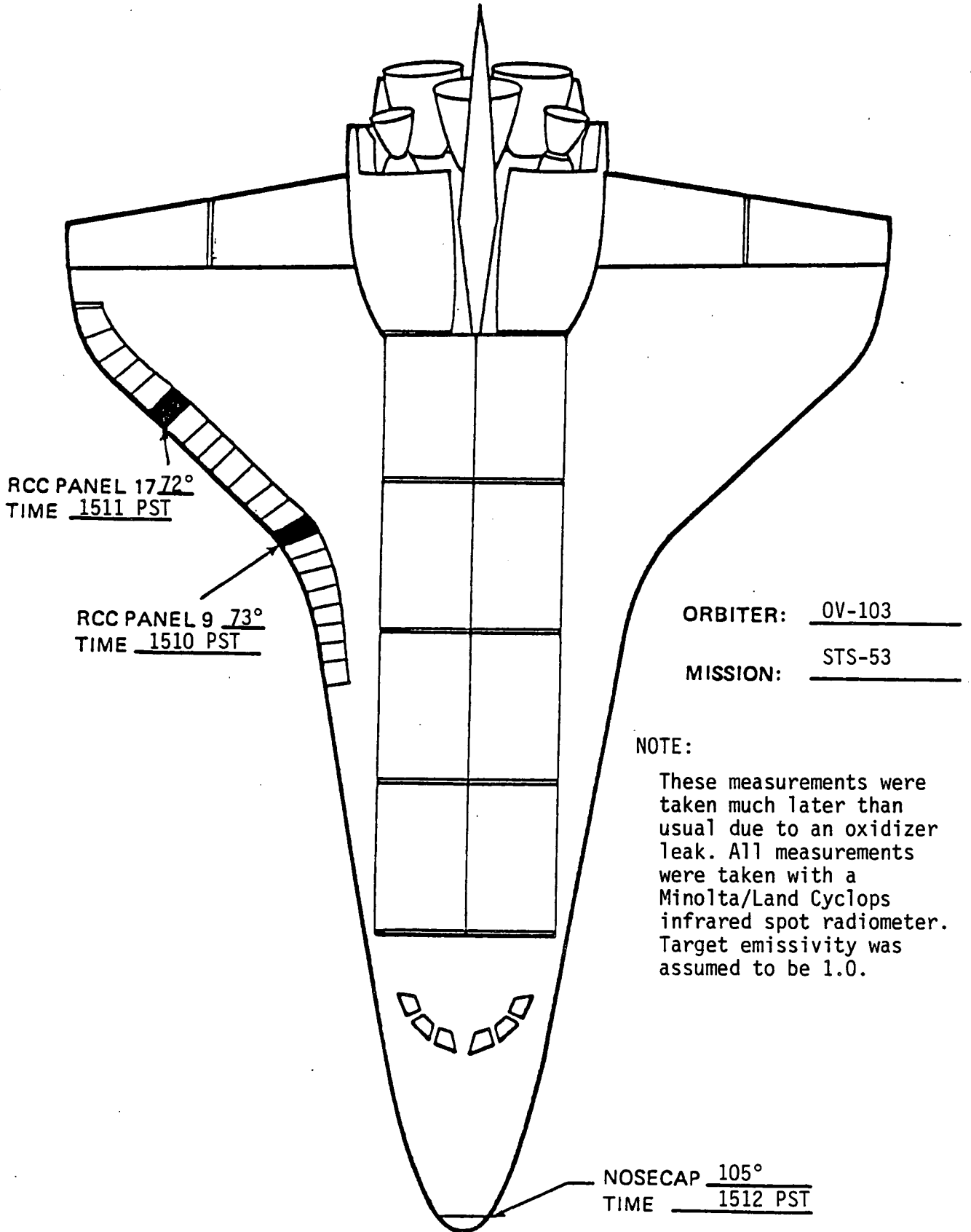

FIGURE 17: ORBITER POST FLIGHT DEBRIS DAMAGE SUMMARY

	LOWER SURFACE		ENTIRE VEHICLE	
	HITS > 1 INCH	TOTAL HITS	HITS > 1 INCH	TOTAL HITS
STS-6	15	80	36	120
STS-8	3	29	7	56
STS-9 (41-A)	9	49	14	58
STS-11 (41-B)	11	19	34	63
STS-13 (41-C)	5	27	8	36
STS-14 (41-D)	10	44	30	111
STS-17 (41-G)	25	69	36	154
STS-19 (51-A)	14	66	20	87
STS-20 (51-C)	24	67	28	81
STS-27 (51-I)	21	96	33	141
STS-28 (51-J)	7	66	17	111
STS-30 (61-A)	24	129	34	183
STS-31 (61-B)	37	177	55	257
STS-32 (61-C)	20	134	39	193
STS-29	18	100	23	132
STS-28R	13	60	20	76
STS-34	17	51	18	53
STS-33R	21	107	21	118
STS-32R	13	111	15	120
STS-36	17	61	19	81
STS-31R	13	47	14	63
STS-41	13	64	16	76
STS-38	7	70	8	81
STS-35	15	132	17	147
STS-37	7	91	10	113
STS-39	14	217	16	238
STS-40	23	153	25	197
STS-43	24	122	25	131
STS-48	14	100	25	182
STS-44	6	74	9	101
STS-45	18	122	22	172
STS-49	6	55	11	114
STS-50	28	141	45	184
STS-46	11	186	22	236
STS-47	3	48	11	108
STS-52	6	152	16	290
AVERAGE	14.8	92.1	22.2	129.6
SIGMA	7.7	47.0	11.0	61.6
STS-53	11	145	23	240

MISSIONS STS-23, 24, 25, 26, 26R, 27R, 30R, AND 42 ARE NOT INCLUDED IN THIS ANALYSIS SINCE THESE MISSIONS HAD SIGNIFICANT DAMAGE CAUSED BY KNOWN DEBRIS SOURCES

ORBITER TPS DEBRIS DAMAGE STS-29 THROUGH STS-53

Figure 18.

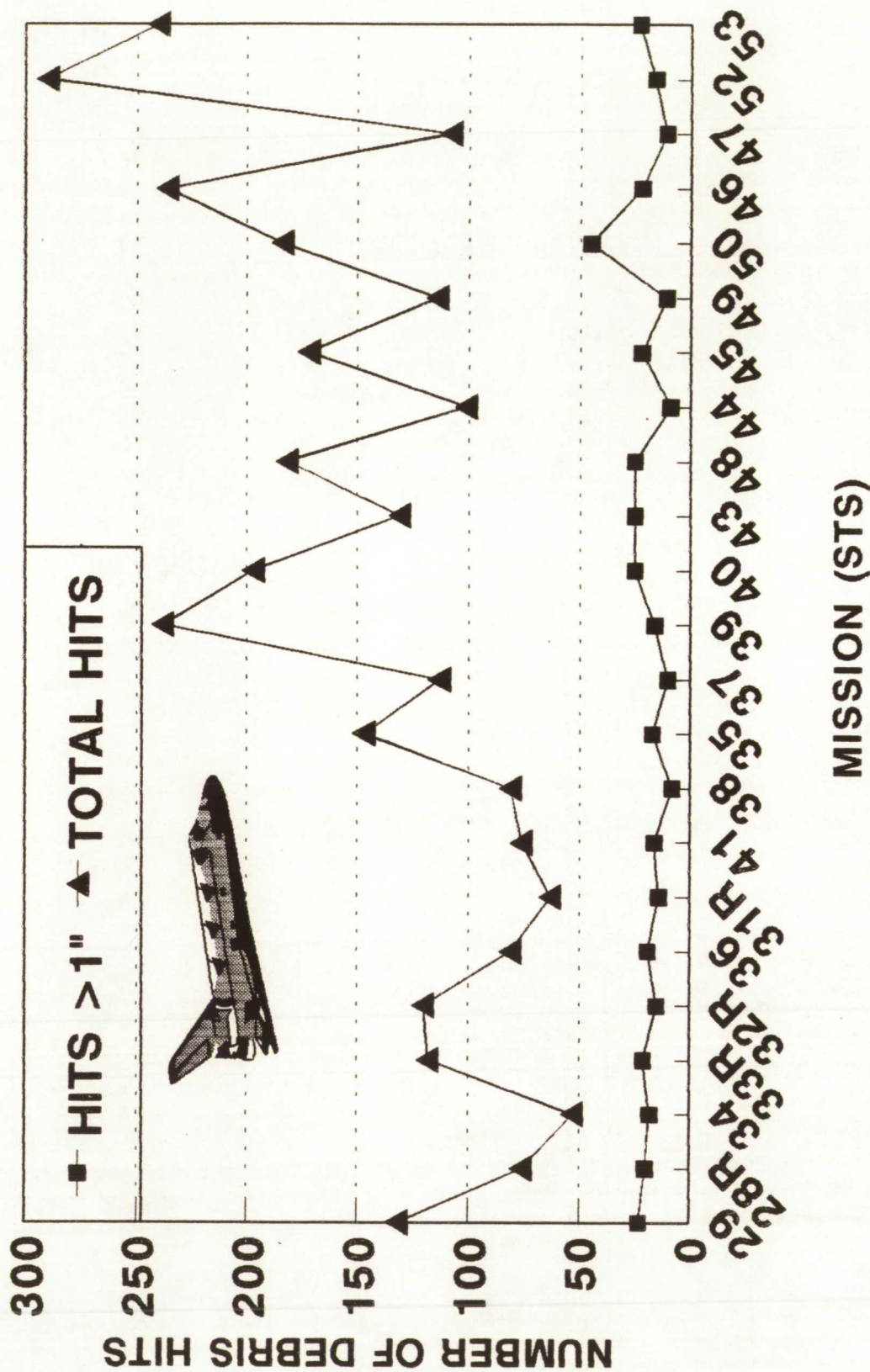

COMPARISON TABLE

Figure 19.

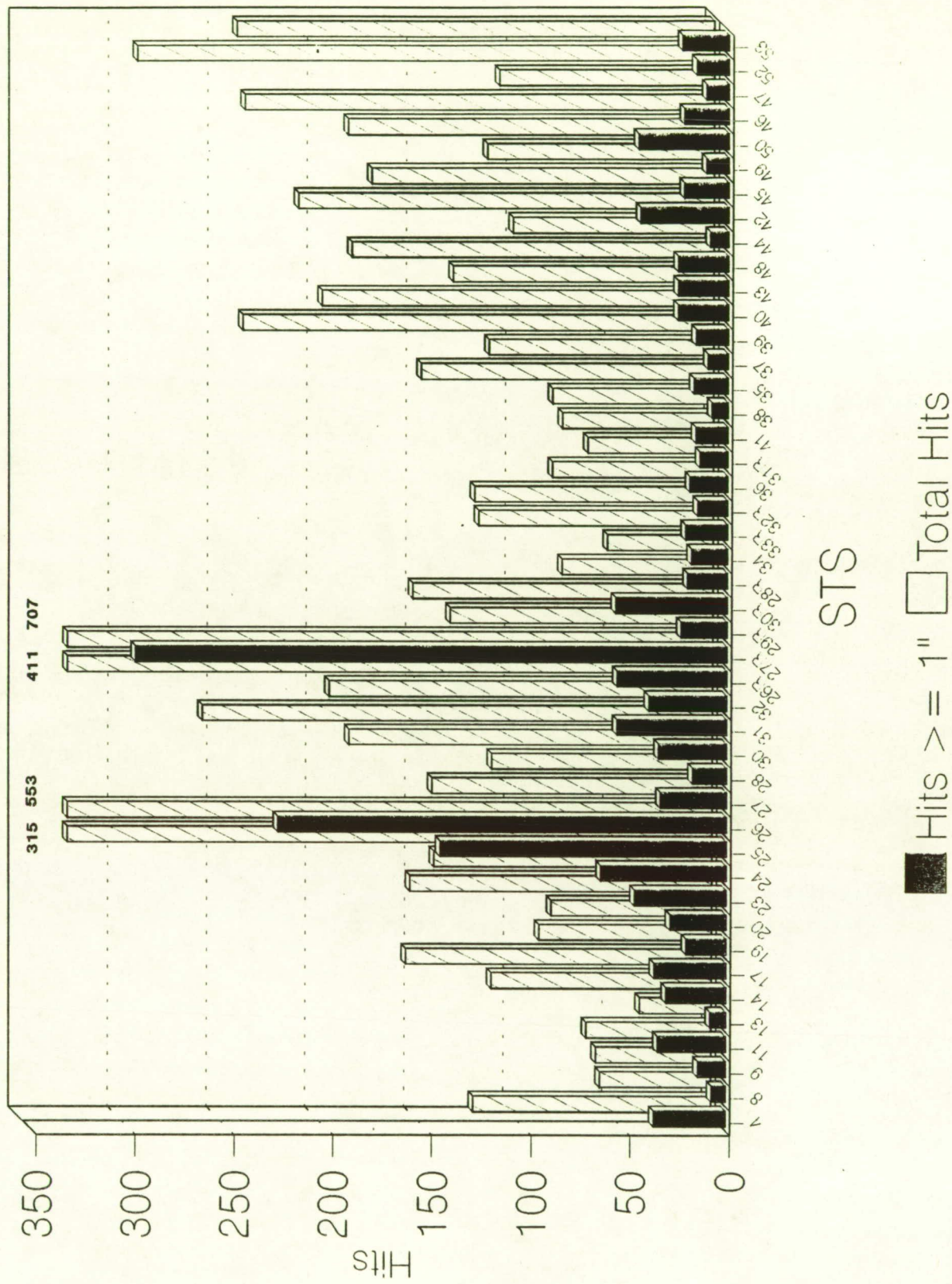



Overall view of Orbiter left side



Overall view of Orbiter right side



The Orbiter lower surface tiles sustained a total of 145 hits, of which 11 had a major dimension of 1-inch or greater. The majority of the tile damage occurred on the right side of the vehicle and was attributed to ice from the LO2 feedline.



The tile material which was found embedded in the RH SRB aft skirt BSM fairing insulation may have originated from a tile on the Orbiter forward RH lower surface. The area of missing material from this tile included some OEM tile identification markings similar to that found on the particles embedded in the BSM TPS.

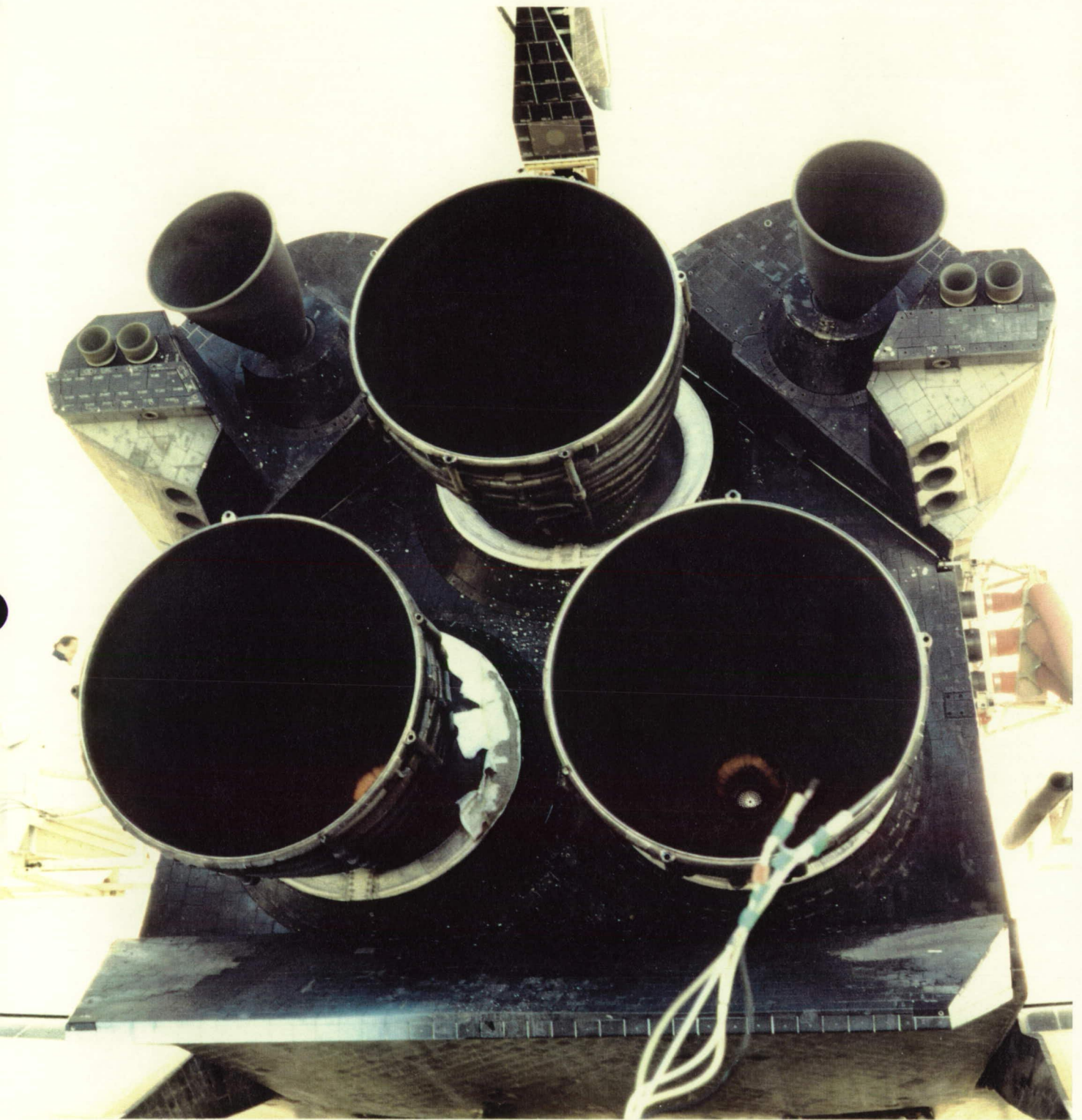

Tile damage on the base heat shield was typical. Four SSME #2 Dome Mounted Heat Shield closeout blanket sacrificial panels were nearly detached and the underlying batting material was exposed.



Tiles on the left OMS pod leading edge sustained more damage than usual. The cause of this damage is still undetermined.



Overall view of the LH2 ET/ORB umbilical. All separation ordnance devices functioned properly. No flight hardware was found on the runway below the umbilical when the ET door was opened.



Overall view of the L02 ET/ORB umbilical. All separation ordnance devices functioned properly. No flight hardware was found on the runway below the umbilical when the ET door was opened.

8.0 DEBRIS SAMPLE LAB REPORTS

A total of seven samples were obtained from OV-103 Discovery during the STS-53 post landing debris assessment (reference Figure 14) at Ames-Dryden Flight Research Facility. The seven submitted samples consisted of 6 window wipes (Windows 1-6) and 1 sample wipe from the LO2 umbilical door lower surface. The samples were analyzed by the NASA KSC Microchemical Analysis Branch (MAB) for material composition and comparison to known STS materials. Debris sample analysis involves the placing and correlating of particles with respect to composition, thermal (mission) effects, and availability. Debris sample results and analyses are listed by Orbiter location in the following summaries. In addition, a summary of the RH SRB aft skirt debris analysis is included in this section.

Orbiter Windows

Results of the window sample analysis revealed the presence of the following materials:

1. Metallics
2. RTV, silica-rich tile, insulation glass fibers
3. Paints, primer, rust
4. Organics
5. Earth compounds

Debris analysis provided the following correlations:

1. Metallic particles (aluminum, zinc carbon and stainless steel alloys) are common to SRB/BSM exhaust residue, but are not considered to be a debris concern in this quantity (micrometer) and have not generated a known debris effect. Also noted was tin-lead, suspected to be a "solder-type" origin in ground processing.
2. RTV, silica-rich tile, and insulation glass fibers originate from Orbiter thermal protection system (TPS).
3. Paints and primer are of flight hardware/facility/GSE origin; rust is an SRB BSM exhaust residue.
4. Organics are being analyzed by chemical fingerprint (Infrared Spectroscopy) method; final results are pending. Preliminary results are similar to those of STS-52 (included in this report).
5. Earth compounds (alpha-quartz, muscovite, calcite, and salt components) originated from the landing site.

L02 Umbilical Door Lower Surface

Results of the L02 umbilical door lower surface wipe sample indicated the presence of the following materials:

1. Tile and insulation material
2. Dense Silicon Carbide
3. Paint and rust
4. Earth compounds
5. Organics

Debris analysis provided the following correlations:

1. Tile and insulation material originated from Orbiter thermal protection system (TPS)
2. Dense Silicon Carbide has been evaluated by Orbiter TPS engineering and determined the origin to be OML coating of gap filler. This material is applied in liquid form to the exposed edge of gap filler for heat protection.
3. Paint is of flight hardware/facility/GSE origin; rust is of SRB BSM exhaust origin
4. Earth compounds (calcite and salt components) originated from the landing site
5. Organics originated from umbilical closeouts; the grease-like material was found to be a hydrocarbon of as yet unidentified origin.

Debris from RH SRB Aft Skirt TPS Incision

During SRB post-flight assessment and recovery operations, debris was discovered in a damaged area on the RH aft skirt center BSM mounting base cover cork insulation. This debris was tested by the MSFC and Rockwell-Downey Materials and Processes laboratories. Results indicated the presence of the following materials:

1. Tile and tile coating
2. Iron oxide/silica
3. Cork insulation
4. Trace inorganic elements

Debris analysis provides the following correlations:

1. Tile and tile coating material originated from Orbiter Thermal Protection System (TPS). The coating material exhibited a portion of the "dot" tile number printing. Post-flight inspection of OV-103 found lower surface tile damage with a "hit" that included a portion of the dot part number.

2. Iron oxide/silica is probably RTV residue.
3. Cork insulation was found mingled with tile particles, the cork insulation originated from the SRB aft skirt.
4. Trace inorganic elements (silica, aluminum, phosphorus, zinc, sulfur, chlorine, potassium, calcium, titanium, antimony, and iron) were noted in particles from the sample. These elements are not unusual to the known Shuttle program process compounds, but did not directly match a specific material.

STS-52 Organic Analysis

Results of the STS-52 Organic Analysis revealed the presence of the following materials:

1. Polymeric
2. Rubbery
3. Fibrous
4. Proteinaceous

Debris analysis provided the following correlations:

1. Polymeric materials included items with styrene-acrylonitrile, polyethylene terephthalate, aromatic polyamide, and cellulosic characteristics. This variety is similar to that observed in STS-47 samples and appear to originate from Orbiter window protective covers.
2. Rubbery materials were found to be methyl silicone, as in red RTV, and a calcium carbonate filled adhesive/sealant most likely from the window protective covers.
3. Fibrous material detected in this sampling set were cellulosic in nature and probably of sample cloth origin.
4. Proteinaceous (amide characteristics) material found were of possible insect origin.

Conclusions

The STS-53 mission sustained Orbiter tile damage to a greater than average degree. However, the chemical analysis results from post flight samples did not point to a single source of damaging debris.

Orbiter window samples showed evidence of SRB BSM exhaust, Orbiter TPS, landing site products, organics, paint, and the presence of "solder-type" material (from ground processing).

The LO2 umbilical sample indicated the presence of silicon carbide, a new finding for the last mission report (STS-52), but can now be identified as gap filler coating.

The variety of residuals attributed to known sources did not seem to change significantly when compared to previous sample data (reference Figure 20). The results of this analysis are similar to that of previous missions in that new entries do not appear to be related to a debris problem.

STS	Sample Location				
	Windows	Wing RCC	Lower Tile Surface	Umbilical	
53	<p>Metallics - BSM Residue (SRB) - Solder (Launch Site) RTV, Tile (ORB TPS) Insulation Glass (ORB TPS) Calcite, Salt (Landing Site) Organics Paint</p>			<p>LO2 Umbilical Door - - Closeout Mat'l (ORB TPS) - Hydrocarbon "grease-like" sub.</p>	<p>RH SRB Aft Skirt Damage site - - Tile, Tile coating mat'l (ORB TPS)</p>
52	<p>Metallics - BSM Residue (SRB) RTV, Tile (ORB TPS) Insulation Glass (ORB TPS) Calcite, Salt (Landing Site) Organics-Fibrous mat'l, red RTV Organics-filled rubber, plastic polymers Paint</p>				<p>HPSI Tile Damage Site- -Tile Mat'l and silicon carbide (ORB TPS) -Paints -Calcite, salts (Landing Site)</p>
47	<p>Metallics - BSM Residue (SRB) RTV, Tile (ORB TPS) Insulation Glass (ORB TPS) Calcite, Salt (Landing Site) Window Polish Residue (ORB) Organics-Fibrous mat'l, red RTV Organics-filled rubber, plastic polymers Paint</p>		Silica-rich Tile (ORB TPS)		
46	<p>Metallics - BSM Residue (SRB) RTV, Tile (ORB TPS) Insulation Glass (ORB TPS) Calcite, Alpha-Quartz, Salt (Landing Site) Organics-Adhesive, Foam, red RTV Organics-filled rubber, plastic polymers Paint</p>				<p>Crew Hatch Window - Metallics - BSM Residue (SRB) - Alpha-Quartz, Salt (Landing Site) - RTV, Tile (ORB TPS) - Paint - Organics</p>
50	<p>Metallics - BSM Residue (SRB) RTV, Tile (ORB TPS) Insulation Glass (ORB TPS) Window Polish Residue (ORB) Mica, Calcium, Salt (Landing Site) Organics-Adhesive, Foam Organics-Plastic Polymers Paint</p>		Silica-Rich Tile (ORB TPS)		<p>Orbiter Vertical Stabilizer - Tile Coating (ORB TPS) - Structural Coating Glass "E-Glass"</p>
49	<p>Metallics - BSM Residue (SRB) RTV, Tile (ORB TPS) Insulation Glass (ORB TPS) Mica, Calcium, Salt (Landing Site) Organics Paint</p>	<p>RTV, Tile (ORB TPS) Rust - BSM Residue (SRB) Muscovite, Salt (Landing Site) Organics Paint</p>	<p>RTV, Tile (ORB TPS) Insulation Glass (ORB TPS) Rust - BSM Residue (SRB) Calcium Mat'l, Salt (Landing Site Soil) Organics Paint</p>		

Figure 20. Orbiter Post Landing Microchemical Sample Results

STS	Sample Location			
	Windows	Wing RCC	Lower Tile Surface	Umbilical
45	Metallics - BSM Residue (SRB) RTV, Tile (ORB TPS) Insulation Glass (ORB TPS) Calcite, Salt (Landing Site) Window Polish Residue (ORB) Organics Paint		Iron - Rich Matl Paint	
42	Metallics - BSM Residue (SRB) RTV, Tile (ORB TPS) Insulation Glass (ORB TPS) Calcite, Salt (Landing Site) Muscovite (Landing Site) Organics Paint		Metallics - BSM Residue (SRB) Tile, Tile Coating (ORB) Salt (Landing Site) Paint	Organics RH Fuselage - Tile Coating (ORB)
44	Metallics - BSM Residue (SRB) RTV, Tile (ORB TPS) Insulation Glass (ORB TPS) Calcite, Salt (Landing Site) Muscovite (Landing Site) Organics Paint			Organics Silica-Magnesium Matl
48	Metallics - BSM Residue (SRB) RTV, Tile (ORB TPS) Insulation Glass (ORB TPS) Calcite, Salt (Landing Site) Muscovite (Landing Site) Organics Paint			Metallics Silica - Rich Matl (Landing Site) Orb Umbilical CAO Matl (ORB) Paints
43	Metallics - BSM Residue (SRB) RTV, Tile (ORB TPS) Insulation Glass (ORB TPS) Calcite, Salt (Landing Site) Window Polish Residue (ORB) Organics Paint		RTV, Tile (ORB TPS) Metallics - BSM Residue (SRB) Salt (Landing Site) Organics Paint	Runway - FRSI Coating (ORB)
40	Metallics - BSM Residue (SRB) RTV, Tile (ORB TPS) Insulation Glass (ORB TPS) Calcite, Salt (Landing Site) Window Polish Residue (ORB) Organics Paint	Metallics - BSM Residue (SRB) RTV, Tile (ORB) Insulation Glass (ORB TPS) Epsilote Foam (RCC Prot. Covers) Organics Paint	RTV, Tile (ORB TPS)	Metallics - BSM Residue (SRB) RTV, Tile (ORB TPS) Insulation Glass (ORB TPS) Organics (ORB Umb CAO) Paint

Figure 20. Orbiter Post Landing Microchemical Sample Results

STS	Sample Location			
	Windows	Wing RCC	Lower Tile Surface	Other
39		Metallics - BSM Residue (SRB) RTV, Tile (ORB) Insulation Glass (ORB TPS) Esoelite Foam (RCC Prot. Covers) Organics Paint Hypalon Paint (SRB)	Tile (ORB TPS) Insulation Glass (ORB TPS)	
37	Metallics - BSM Residue (SRB) RTV, Tile (ORB TPS) Insulation Glass (ORB TPS) Calcite, Salt (Landing Site) Organics	Metallics - BSM Residue (SRB) RTV, Tile (ORB) Insulation Glass (ORB TPS) Calcite, Salt (Landing Site) Organics Paint	RTV, Tile (ORB TPS) Insulation Glass (ORB TPS) Metallics - BSM Residue (SRB) Calcite, Salt (Landing Site) Organics	
35	Metallics - BSM Residue (SRB) RTV, Tile (ORB TPS) Insulation Glass (ORB TPS) Calcite, Salt (Landing Site) Window Polish Residue (ORB) Organics Paint	Metallics - BSM Residue (SRB) RTV, Tile (ORB) Organics	RTV, Tile (ORB TPS) Metallic - Rust, Aluminum Welding Slag (Facility)	
38		RTV, Tile (ORB TPS) Hypalon Paint (SRB) Esoelite Foam (RCC Prot. Cover)	Tile (ORB TPS)	
41	Metallics - BSM Residue (SRB) RTV, Tile (ORB TPS) Insulation Glass (ORB TPS) Calcite, Salt (Landing Site) Organics	Tile (ORB TPS) Salt (Landing Site)	Tile (ORB TPS)	Flwd FFSI - Silicon Mart (ORB TPS) Calcite (Landing Site) Fluorocarbon (Vion-ORB Umb) Foam (ORB CO)
31R	Metallics - BSM Residue (SRB) RTV, Tile (ORB TPS) Insulation Glass (ORB TPS) Calcite, Salt (Landing Site) Organics	Metallics - BSM Residue (SRB) RTV, Tile (ORB TPS) Insulation Glass (ORB TPS) Mica (Landing Site) Organics Foam Insulation (ET/SRB) Paint	RTV, Tile (ORB TPS) Insulation Glass (ORB TPS) Mica (Landing Site) Paint	
36	Metallics - BSM Residue (SRB) RTV, Tile (ORB TPS) Insulation Glass (ORB TPS) Mica, Salt (Landing Site) Paint	Rust - BSM Residue (SRB) Tile (ORB TPS) Paint Organics	RTV, Tile (ORB TPS) Insulation Glass (ORB TPS) Mica (Landing Site) Organics Microballoon (ET/SRB)	Rust - BSM Residue (SRB) RTV, Insulation Glass (ORB TPS) Microballoon (ET/SRB) Calcite (Landing Site) Foam, Organics (ORB Umb CO)

Figure 20. Orbiter Post Landing Microchemical Sample Results

STS	Sample Location				Other
	Windows	Wing RCC	Lower Tile Surface	Umbilical	
32R	Metallics - BSM Residue (SRB) RTV, Tile (ORB TPS) Insulation Glass (ORB TPS) Mica, Salt (Landing Site) Paint	Metallics - BSM Residue (SRB) Tile (ORB TPS) Carbon Fibers Titanium	Metallics - BSM Residue (SRB) RTV, Tile (ORB TPS)	Metallics - BSM Residue (SRB) RTV, Insulation Glass (ORB TPS) Phenolic Microballoon (ET/SRB) Quartz, Calcite (Landing Site) Organics	
33R	Metallics - BSM Residue (SRB) RTV, Tile (ORB TPS) Insulation Glass (ORB TPS) Miscellaneous Matl, Salt (Landing Site) Window Polish Residue (ORB) Paint	Metallics - BSM Residue (SRB) Tile (ORB TPS) Insulation Glass (ORB TPS) Mica, Spar, Salt (Landing Site) Organics	RTV, Tile (ORB TPS)	Rust - BSM Residue (SRB) RTV, Insulation Glass (ORB TPS) Phenolic Microballoon (ET/SRB) Paint Organics	Crew Hatch Window - Rust - BSM Residue (SRB) - Alpha Quartz (TPS/Landing Site) - Paint - Organics
34	Metallics - BSM Residue (SRB) RTV, Tile (ORB TPS) Insulation Glass (ORB TPS) Alpha-Quartz, Silicates, Salt (L/S) Window Polish Residue (ORB)	Metallics - BSM Residue (SRB) RTV, Tile (ORB TPS) Insulation Glass (ORB TPS) Paint	RTV, Tile (ORB TPS) Stainless Steel Washer	RTV (ORB) Foam (ORB) Viton Rubber (ORB) Metallics - BSM Residue (SRB) Phenolic Microballoon (ET/SRB) Silicates, Calcium (Landing Site) Paint	
28R	Silicone (ORB FRCS Cover Adhesive)	Silicates (Landing Site) Paint Charred Silicone Brass Chip	RTV, Tile (ORB TPS) Clay, Sand, Quartz (Landing Site) Metallics - BSM Residue (SRB)	Sand, Silicates (Landing Site) Foam (ORB) RTV (ORB TPS) Korocon, Kapton (ORB) Metallics - BSM Residue (SRB)	OMS Pod - PVC Laminate (ORB TPS 'Shim')
30R	Metallics - BSM Residue (SRB) RTV, Tile (ORB TPS) Insulation Glass (ORB TPS) Clay, Salt (Landing Site) Paint		Metallics - BSM Residue (SRB) RTV, Tile (ORB TPS) Gap Filler (ORB TPS) Clay, Feldspar (Landing Site)		Upper Tile - Tile, Gap Filler (ORB TPS)
28R	RTV, Tile (ORB TPS) Metallics - BSM Residue (SRB) Ablator, Hypalon Paint (SRB)		Tile (ORB TPS) Insulation Glass (ORB TPS) Paint Muscovite - Metallics (Landing Site)	Tile (ORB TPS) Umbilical Foam (ORB) Paint Ablator, Hypalon Paint (SRB) Metallics - BSM Residue (SRB)	Upper Tile - Tile (ORB TPS)
27R	RTV, Tile (ORB TPS)	Hypalon Paint (SRB)	RTV, Tile (ORB TPS) Ablator, Hypalon Paint (SRB)		OMS Pod - Iron Fiber - POL Foam, PRL Paint (ET) - Ablator, Hypalon Paint (SRB)
28R			RTV, Tile (ORB TPS) Paint Rust		

Sample locations vary per mission and not all locations are sampled for every mission.
 () - identifies the most probable source for the material.
 Metallics - includes mostly Aluminum and Carbon Steel alloys

Figure 20. Orbiter Post Landing Microchemical Sample Results

9.0 POST LAUNCH ANOMALIES

Based on the debris inspections and film/video review, 8 Post Launch Anomalies, but no IFA candidates, were observed on the STS-53 mission.

9.1 LAUNCH PAD/FACILITY

1. A metal parts tag, approximately 1.5"x0.75", originated from the aft edge of the LO2 T-0 umbilical interface plate and fell aft past SSME #3 without contacting flight hardware.

2. A red, flexible object, approximately 8"x2" and similar to red vinyl tape, fell out of the LO2 TSM door opening below the ECS ducts and was drawn into the SSME plume by aspiration.

9.2 EXTERNAL TANK

1. The 17-inch flapper valve actuator access port foam plug closeout exhibited a slight leak at the forward corner and was covered by ice/frost.

2. On-orbit photography of the ET after separation revealed three divots in the aft dome spray abort. Three divots occurred in the LH2 tank-to-intertank flange closeout (-Y+Z quadrant).

9.3 SOLID ROCKET BOOSTERS

1. A stud hang-up occurred on HDP #1. The stud remained fully extended until clear of the aft skirt foot, twanged briefly, and then dropped into the holddown post.

2. The RH frustum had 16 MSA-2 debonds and one 1-inch diameter area of missing TPS between the +Y and -Z axes at the 381 ring frame. The LH frustum had 28 MSA-2 debonds over fasteners. Torn and missing MSA-2 (1-inch diameter) from one location between the +Y and +Z axes just aft of the 336 ring frame may have been the result of handling damage.

3. A 10"x3" area of EPON shim was missing from HDP #3. The material was lost prior to water impact (sooted/charred substrate).

9.4 ORBITER

1. Orange vapor (burning hydrogen) was visible between the exit plane and the #9 hatband near the steer horn, or the coolant manifold, on the SSME #2 nozzle -Z side. This event is similar to the cold wall hydrogen leak observed during SSME #2 ignition for STS-44.

Appendix A. JSC Photographic Analysis Summary



ENGINEERING AND SCIENCE PROGRAM

2400 NASA Road 1, P. O. Box 58561, Houston, Texas 77258 (713) 333-5411

January 22, 1992

Greg Katnik
MC/TV-MSD-22
OSB Room 5203R
KSC, Florida 32899

Dear Greg,

The following Summary of Significant Events report is from the Johnson Space Center NSTS Photographic and Television Analysis Project, STS-53 Final Report, and was completed January 20, 1992. Publication numbers are LESC-30617 and JSC-25994-53. The actual document can be obtained through the LESC library/333-6594 or Christine Dailey /483-5336 of the NSTS Photographic and Television Analysis Project.

Christine Dailey 1/22/92
Christine Dailey, Supervisor
Image Analysis Section

2.0 Summary of Significant Events

2.1 Debris

2.1.1 Debris Near the Time of SSME Ignition

2.1.1.1 Debris from the ET LO2 Feedline Upper Bellows (Cameras OTV-054, E-5, E-6, E-25, E-54, E-65A, E-77, E-79)

Multiple light colored pieces of debris, probably ice, were first noted above the ET/Orbiter umbilical disconnects and then fell aft along the vehicle prior to liftoff. The debris originated from the ET LO2 feedline upper bellows. Debris falling aft from above the ET/Orbiter umbilical disconnects has been observed on previous missions. None of the debris appeared to strike the vehicle.

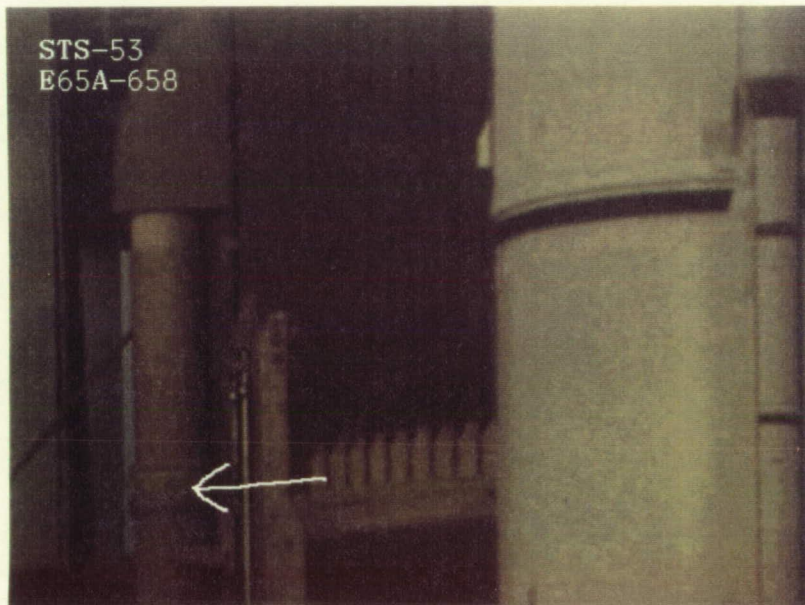

Figure 2.1.1.1 Light Colored Debris Falling Aft along South Side of ET

Figure 2.1.1.1 shows multiple white pieces of debris, probably ice, falling aft toward the MLP to the right of the Orbiter's centerline.

2.0 Summary of Significant Events

2.1.1.2 White Debris From the ET/Orbiter Umbilicals

(Cameras OTV-009, OTV-049, OTV-059, OTV-063, E-1, E-4, E-5, E-6, E-14, E-16, E-18, E-19, E-25, E-30, E-34, E-36, E-52, E-65, E-77)

Multiple pieces of white debris, probably ice, were seen falling from the ET/Orbiter umbilical area and fall aft along the body flap. One piece of debris may have contacted the aft edge of the body flap. Ice debris was seen to strike the lower edge of the umbilical door at 337:13:23:56.587 UTC. No damage to the Shuttle Launch Vehicle (SLV) was detected. More than usual ice build up was noted on the 17 inch and 4 inch lines at the flanges and around the umbilical baggie material. No follow up analysis has been requested.

2.1.1.3 White Debris From the ET/SRB Aft Attach Points

(Cameras E-1, E-4, E-57)

White debris, probably ice, originated from the north side of the ET/RSRB and the ET/LSRB aft attach struts and fell aft prior to and during liftoff. No further photographic analysis has been requested.

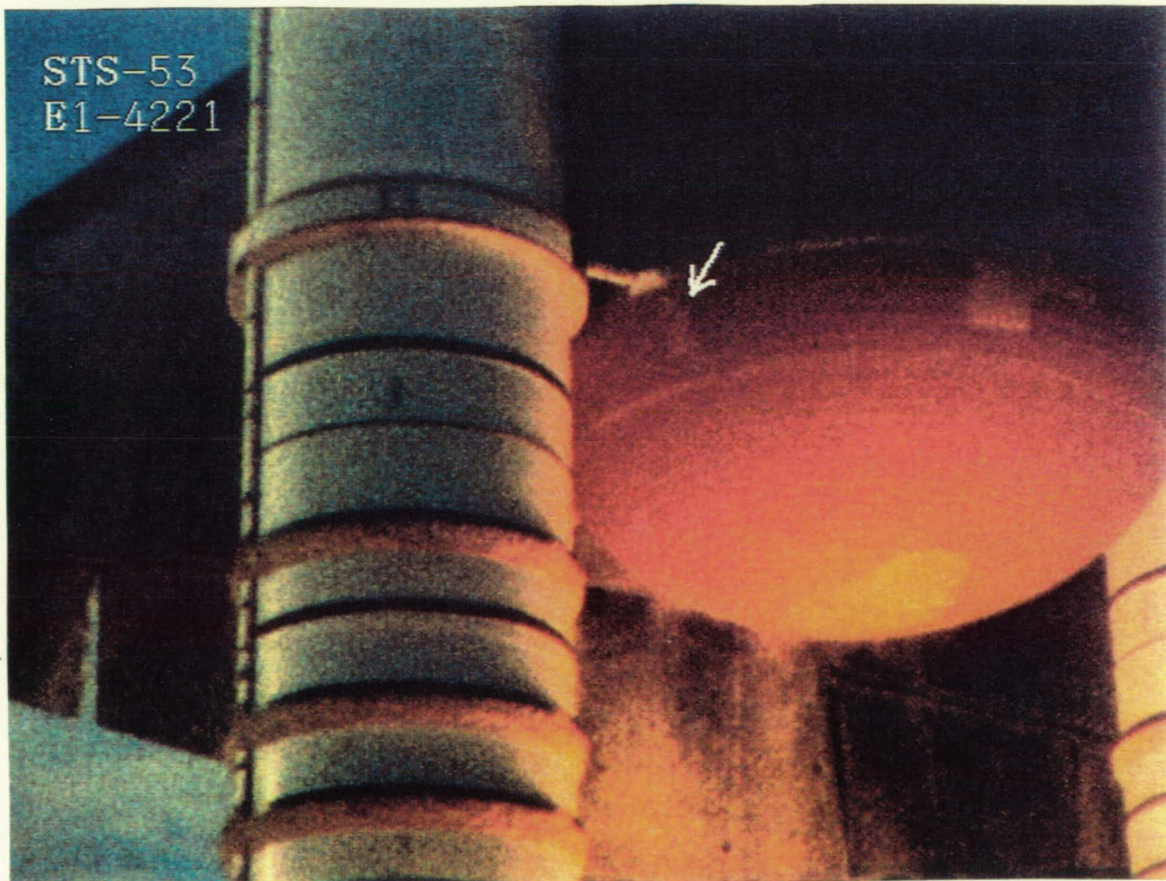

Figure 2.1.1.3 White Debris from the North Side of the ET SRB Aft Attach Struts

Figure 2.1.1.3 shows the white debris falling from the north side of the RSRB/ET aft attach strut. The debris falls aft and south between the SRBs but did not appear to strike the SLV.

2.0 Summary of Significant Events

2.1.1.4 Debris Between the SRBs (Camera E-5)

Multiple pieces of small light colored debris were first seen between the SRBs and fell toward the MLP and bodyflap after SSME startup. This debris may have originated from the ET/SRB aft attach points. None of the debris appeared to strike the SLV. No follow up analysis has been requested.

2.1.1.5 Debris From LO2 TSM Umbilical Disconnect Area (Cameras E-17, E-19)

A single red rectangular shaped piece of debris fell aft from the LO2 TSM feed line area prior to liftoff. A single, light colored, rectangular piece of debris first noted in the LO2 TSM carrier plate area fell aft prior to liftoff. No further photographic analysis has been requested.

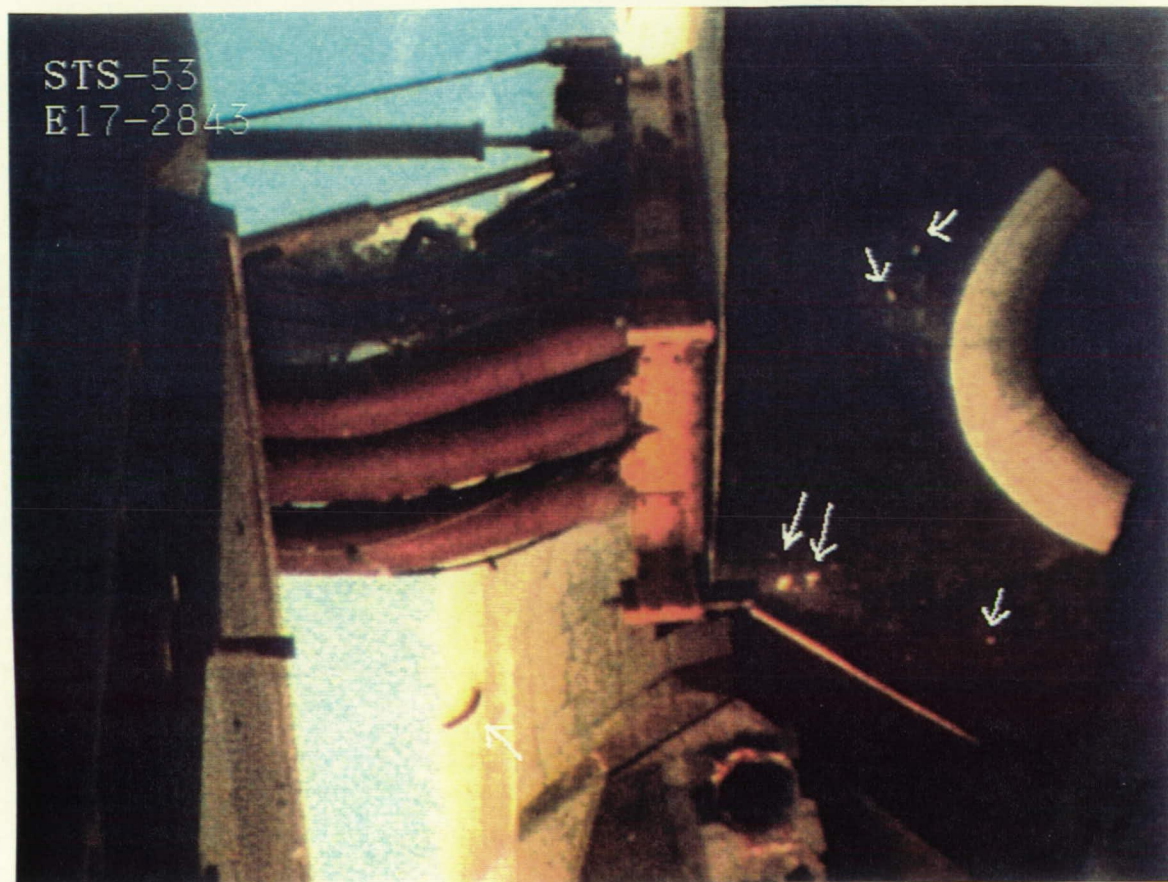

Figure 2.1.1.5 Debris from the LO2 TSM Carrier Plate

Figure 2.1.1.5 shows a red paper like piece of debris falling aft below the LO2 TSM. Also shown in this figure is TPS erosion of the base heat shield near SSME #3.

2.0 Summary of Significant Events

2.1.2 Debris Near the Time of SRB Ignition

2.1.2.1 Holddown Post Debris (Cameras E-8, E-9)

A single dark, curved piece of debris was seen at the time of the bolt release at HDP #M-1 (camera E-9). This piece of debris fell on to the holddown post shoe and then into the RSRB flame duct. No further photographic analysis has been requested.

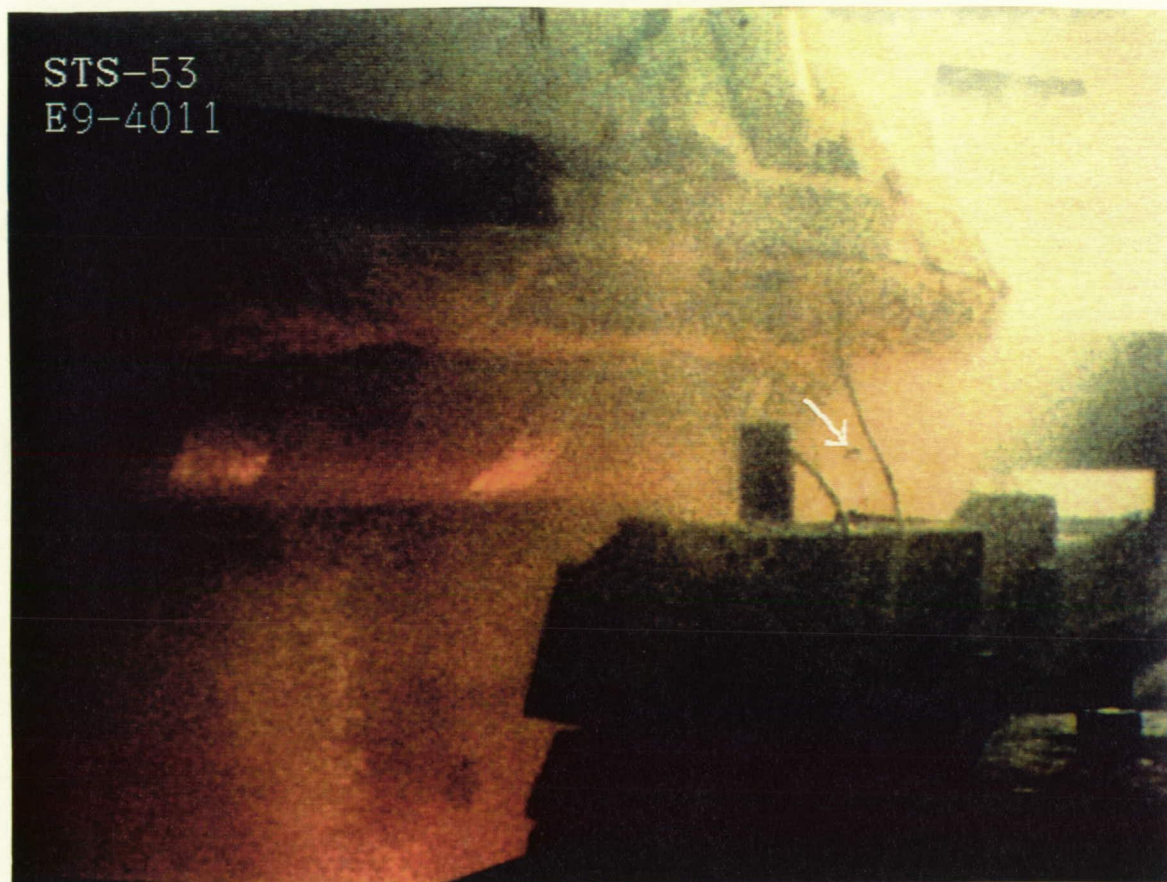

Figure 2.1.2.1 Debris First Seen Near the Holddown Post Area

Figure 2.1.2.1 shows a piece of debris falling from the HDP #M-1 area. This debris seen between the pyrotechnic initiation controller (PIC) wires was first seen as the bolt released from the DCS hole.

A single dark piece of debris was seen near the debris containment system (DCS) area of HDP #M-2 (camera E-8) at liftoff.

2.0 Summary of Significant Events

2.1.2.2 SRB Flame Duct Debris (Task #7) *(Cameras E-5, E-25)*

A fast moving circular piece of debris was noted traveling outward from the RSRB flame trough towards the LO2 TSM.

The trajectory of the debris was digitized on a Film Motion Analyzer using film from camera E-25. The object was also seen in the camera E-5 film but only the last stages of its trajectory were visible. In the camera E-5 film, the object appeared to be circular. The two dimensional (parallel to the image plane) velocity of this debris was calculated to be 66.5 feet per second. The velocity represents a minimum since the motion into or out of the optical axis could not be determined. None of the debris appeared to strike the orbiter. Appendix D Task #7 contains the detailed analysis including a plot of the debris trajectory as a function of time.

2.1.3 Debris After Liftoff

Multiple pieces of debris fell aft of the SLV after liftoff. The debris falling away from the vehicle during the STS-53 ascent was similar to that seen on previous mission film and video views.

2.1.3.1 Light Colored Debris in Exhaust Plume During Ascent *(Camera KTV-4A)*

A light colored piece of debris was first seen near the left side of the vehicle exhaust plume at approximately 72.4 seconds mission elapsed time (MET). The debris traveled to the right across the field of view. This debris was only seen on KTV-4A. The origin of the debris could not be determined. No follow up analysis has been requested. This debris was only seen on KTV-4A. The origin of the debris could not be determined.

2.1.3.2 Debris in Exhaust Plume Prior to SRB Separation *(Cameras ET-208, E-208)*

A small piece of debris was noted below the SRB exhaust plume at approximately 122.6 seconds MET and then fell aft. A second light colored piece of debris was seen above the SRB exhaust plume at approximately 122.8 seconds MET. The origin of this debris could not be determined. Debris observed during this time period have been observed on previous missions. No follow up analysis has been requested.

2.1.3.3 Debris in Exhaust Plume After SRB Separation *(Cameras ET-208, E-208)*

Multiple light colored pieces of debris were seen falling aft of the vehicle after SRB separation. The debris was first seen in the SRB exhaust plume and appeared to originate from the SRBs. Debris in the SRB exhaust plumes after SRB separation have been observed on previous missions. No follow up analysis has been requested.

2.0 Summary of Significant Events

2.1.4 Debris Strike of RSRB Aft BSM Triple Motor Housing (Task #11) (Cameras E-2, E-5, E-6, E-8, E-9, E-16, E-25, E-52, E-54, E-65A, E-79A, E-205, E-207, E-211, E-213, E-220, E-222, E-223, E-224)

An elliptical scar was noted on the RSRB aft BSM triple motor housing during post recovery inspection. The elliptical scar showed evidence of contact with a Thermal Protection System (TPS) tile. The damaged motor cover was over the center of the triple motors (separate from the fourth motor). The damage was 3" long x 0.5" deep and very narrow. The damaged area was sent to two separate laboratories for independent analysis (USBI and MSFC). Chemical analysis showed that the scar had a high silicon content. A quarter inch piece of debris was found imbedded in the crack. The recovered debris appeared to have original equipment manufacturer (OEM) tile identification markings. The only missing tile material from the Orbiter's lower surface with these markings was located on the Orbiter forward right hand lower surface. The Photo/TV Analysis Project was asked to review all of the STS-53 films in which the RSRB was visible. The results are given in Appendix D Task #11.

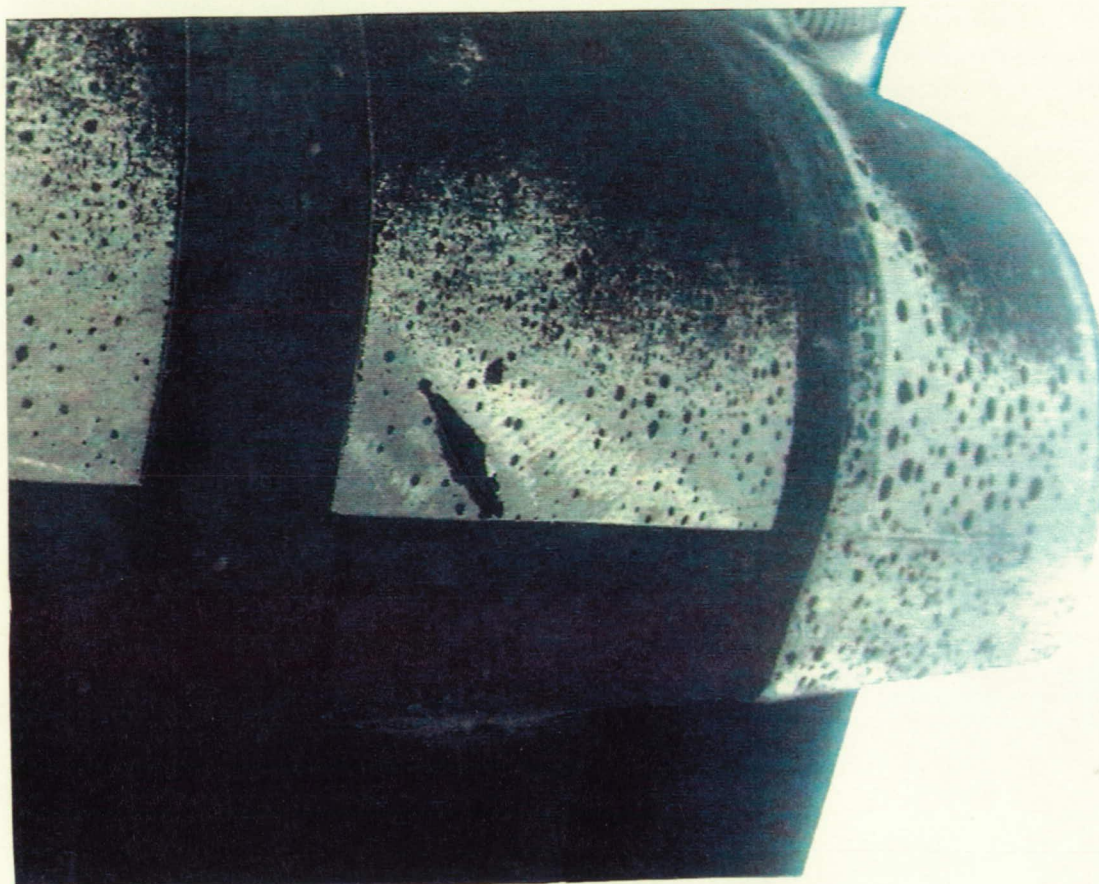

Figure 2.1.4a Elliptical Debris Strike on the RSRB Aft BSM Triple Motor Housing

Figure 2.1.4a shows an elliptical debris strike on the RSRB aft BSM triple motor housing. The figure is aligned so that the aft end of the RSRB is toward the bottom of the frame (arrow). The scar is aligned from the upper left toward the lower right of the frame.

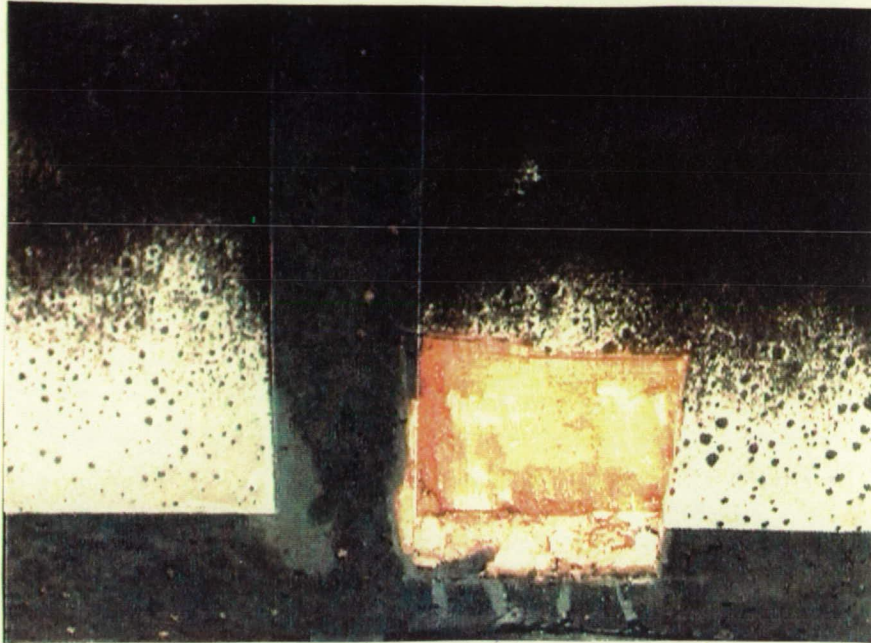

Figure 2.1.4b RSRB Aft BSM Triple Motor Housing without Protective Insulation

Figure 2.1.4b is aligned in the same manner as Figure 2.1.4a with the aft end of the RSRB toward the bottom of the frame. The protective insulation had been removed and sent to two independent laboratories. The elliptical scar is not visible in this view.

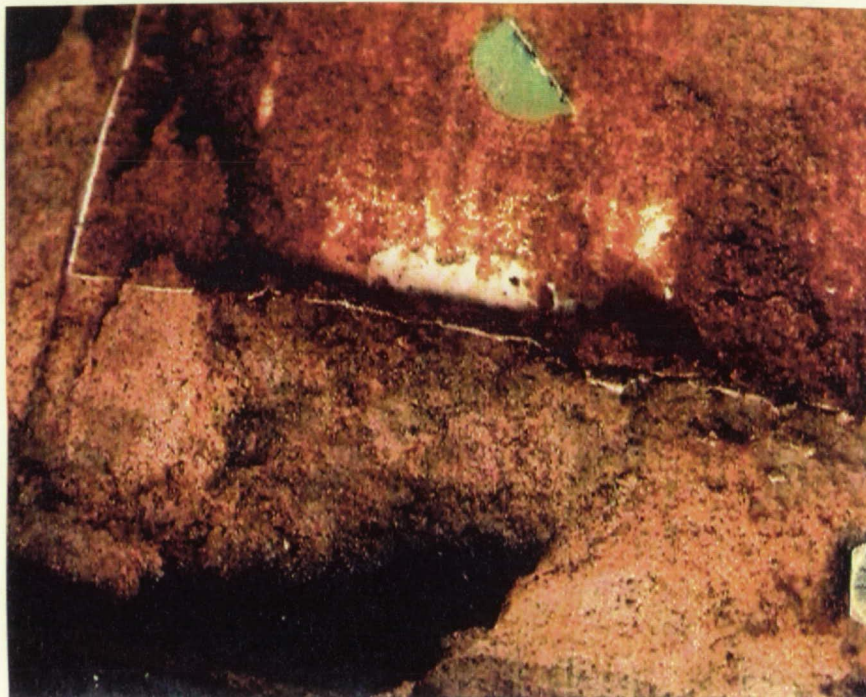

Figure 2.1.4c Close Up View of RSRB Aft Triple Motor Housing

Figure 2.1.4c shows a close up view of the area of interest. The alignment of the (linear feature) is the same as Figure 2.1.4a. The dark metallic scar at the bottom of the frame is the same as the dark metallic scar seen in Figure 2.1.4b (arrow). The green area below the linear feature is

2.0 Summary of Significant Events

thought to be a result of the scarring during ascent. The piece of debris recovered from the analysis is not shown in any of the 2.1.4 figures.

2.2 MLP Events

2.2.1 Holddown Post #M-1 Bolt Hangup (Task #12) (Camera E-9)

A holddown bolt hangup was noted at HDP #M-1. The bolt retracted after the vehicle cleared the length of the bolt. No further photographic analysis has been requested. The bolt released from the RSRB and retracted to its normal position after extending 9.4 inches above the shoe (Appendix D Task #12).

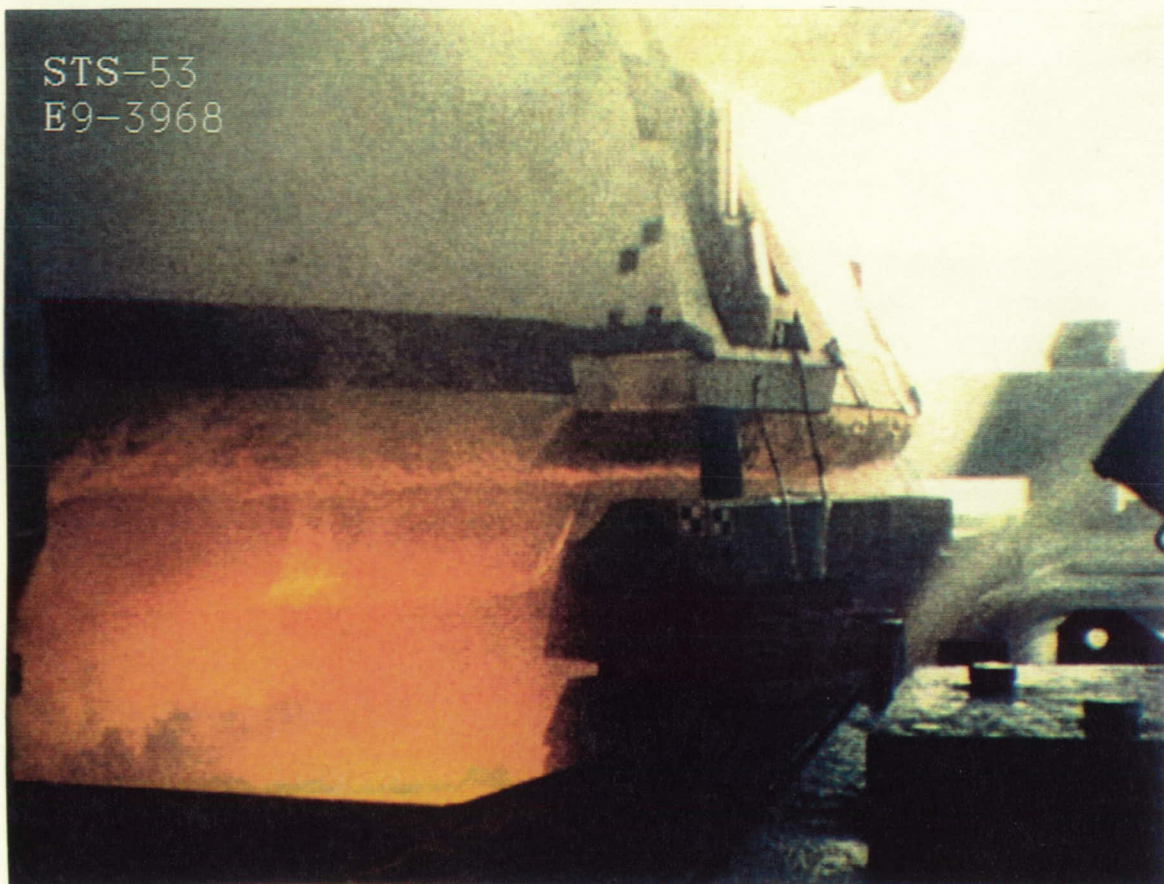

Figure 2.2.1 Holddown Post #M-1 Bolt Hangup

Figure 2.2.1 shows the HDP #M-1 bolt is still contained within the RSRB DCS area after liftoff. HDP bolt hang-ups have occurred on previous missions. To date, the bolt hangup on STS-53 has not been declared an IFA.

2.0 Summary of Significant Events

2.2.2 Orange Vapor at SSME Startup Above the SSME #2 Rim (Cameras E-5, E-16, E-18, E-20)

Orange vapor (possibly free burning hydrogen) was first seen on the north side between the rim and the #9 hatband of SSME #2 at 13:23:56.181 UTC and continued through LOV after liftoff. The vapor appeared to originate from a point source rather than a large general area. Unlike the orange vapor observed on previous missions which lasts only a fraction of a second, this event occurred throughout SSME ignition and startup. Photographic still views of the orange vapor seen above the rim of SSME # 2 were reviewed with the MER manager. No follow up analysis has been requested.

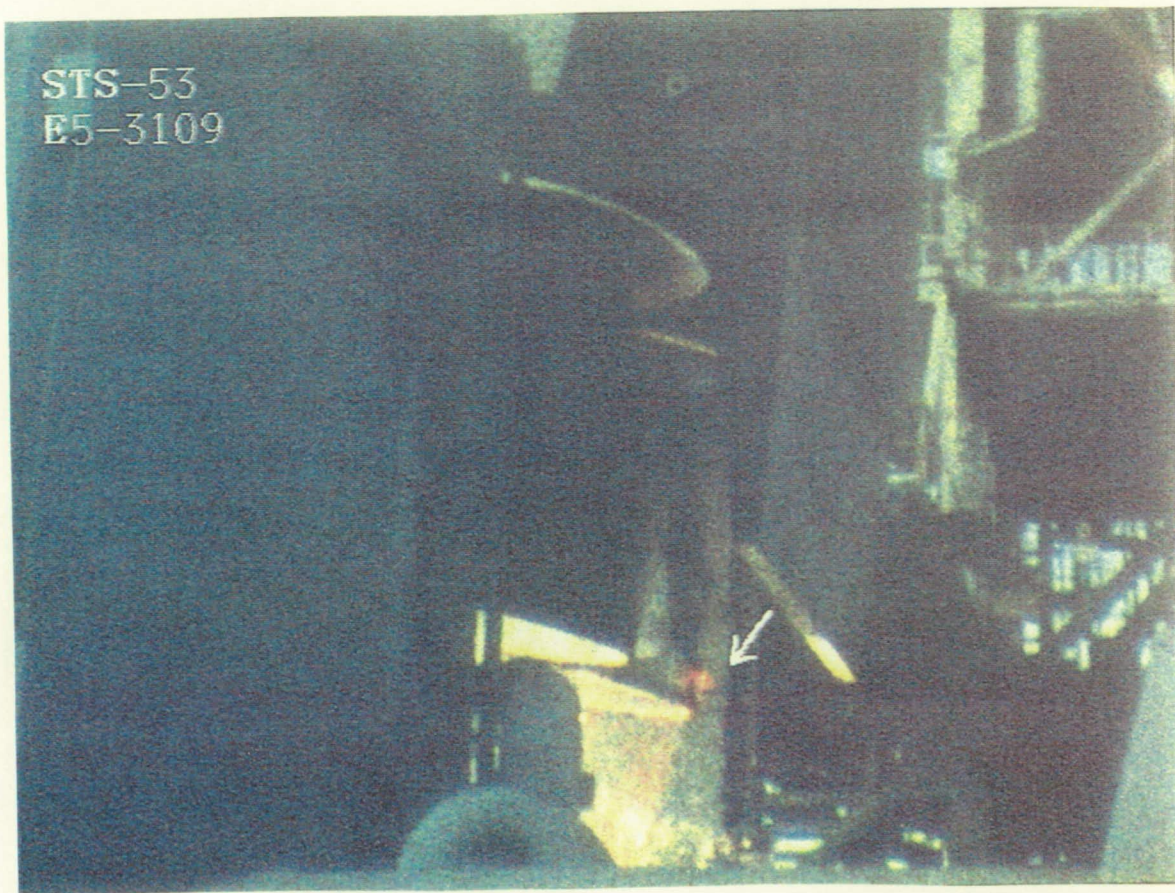

Figure 2.2.2 Vapor Above the Rim of SSME #2

Figure 2.2.2 shows that the orange vapor appears to be a point source rather than generalized free burning hydrogen that surrounds the SSME bells. The orange vapor is located on the northwestern portion of SSME #2. The vapor appeared to be isolated and unique to the SSME #2 bell.

2.0 Summary of Significant Events

2.2.3 Orange Vapor at SSME Startup (Cameras OTV-063, OTV-070, OTV-071, E-19, E-36, E-77)

Orange vapor, possibly free burning hydrogen, was noted near the SSMEs just prior to SSME ignition. The view from OTV-063 showed this vapor moving north under the body flap (possibly due to winds from the southwest). Similar orange vapors have been observed on previous missions. No further photographic analysis has been requested.



Figure 2.2.3 Orange Vapor Under the Body Flap at SSME Ignition

Figure 2.2.3 shows an orange vapor under the bodyflap. The general orange vapor is possibly free burning hydrogen observed at SSME ignition.

2.2.4 Slack in the GH2 Vent Arm Lanyard (Camera E-42)

Slack in the gaseous hydrogen (GH2) vent arm lanyard was noted during latchback. The lanyard contacted the fixed service structure (FSS) and rebounded to contact the vent arm. Otherwise, the vent arm appeared to latch normally. No further photographic analysis has been requested.

2.0 **Summary of Significant Events**

2.2.5 **Loose Thermal Curtain Tape on the RSRB** (Cameras E-7, E-14, E-15, E-25)

A piece of loose thermal curtain tape was seen on the RSRB aft skirt near HDP #M-4 at liftoff. Loose SRB thermal curtain tape has been seen on previous mission films. No follow up analysis has been requested.

2.0 Summary of Significant Events

2.3 Ascent Events

2.3.1 Vapor from Drain Hole in Trailing Edge of The Rudder Speed Brake (Cameras E-34, E-40, E-52, E-222)

Vapor was noted coming from the drain hole on the aft edge of the rudder/speed brake prior to and during liftoff. No further photographic analysis has been requested.

2.3.2 Vapor Near the LH2 Umbilical 17 inch Line (Cameras E-34, E-40)

Vapor was noted near the LH2 17 inch line after liftoff. Normally, ice and vapor events originating from this area occur at SSME startup and conclude prior to liftoff. No further analysis has been requested.



Figure 2.3.2 Vapor from ET/Orbiter Umbilical Areas After Liftoff

Figure 2.3.2 shows vapor from the ET/Orbiter umbilical area after liftoff. Vapor from the ET/Orbiter umbilicals after liftoff is rare but is not considered anomalous due to the cool temperature at liftoff.

2.0 Summary of Significant Events

2.3.3 Vapor from the -Z side of the ET (Cameras E-207, E-211, E-223, E-224)

Vapor was noted to drift from the bottom (-Z side) of the ET after the roll maneuver. The source of the vapor is probably the frost noted on the north side of the ET prior to liftoff. No further photographic analysis has been requested.



Figure 2.3.3 Vapor from -Z side of ET after Liftoff

Figure 2.3.3 shows the vapor originating from the -Z side (north side of the ET at liftoff) of the ET. The source of the vapor is probably the frost observed from this area prior to liftoff. This vapor is not considered an anomaly.

2.3.4 Recirculation (Task #1) (Cameras ET-207 and E-207)

The recirculation or expansion of burning gases at the aft end of the SLV prior to SRB separation has been seen on nearly all previous missions. For STS-53, the start of recirculation was observed to be about 96 seconds MET and the end was noted at approximately 104 seconds MET

2.0 Summary of Significant Events

on camera E-207. This was not a particularly good mission to view recirculation due to the high inclination and the clouds/haze at the time recirculation is generally observed. Appendix D Task #1 contains a summary of recirculation start and stop times for all missions since reflight.

Cameras on which recirculation was observed for STS-53

CAMERA	START (seconds MET)	STOP (seconds MET)
E-207	96	104
ET-207	98	--

NOTE: Due to the launch angle and the intermittent loss of vehicle (LOV) due to cloud cover, only cameras ET-207 and E-207 observed a portion of the recirculation event.

2.3.5 Body Flap Motion (Task #4) (Cameras E-207, E-212)

Films from cameras E-207 and E-212 were re-screened for a subjective measure of the amount of body flap motion visible. A preliminary analysis indicated the presence of slight body flap motion on both cameras. The 400" lens used on E-212 did allow a reasonably good view of the left side of the body flap; however, the atmospheric haze and soft focus hampered the selection of points. E-207 showed the right edge of the body flap but was acquired with a 180" lens (thereby reducing the size of the body flap within the field of view). The small amount of detectable motion on this view made it a poor candidate for quantitative analysis. Also, both views were rendered nearly useless beyond the first few seconds after roll maneuver due to the cloud cover.

A sequence of frames on E-212 that showed the left side of the body flap was selected for analysis. Data was acquired from approximately 18 to 26 seconds MET. Once this data was corrected for camera jitter and viewing angle changes, the magnitude of the noise within these measurements exceeded the magnitude of the bodyflap movement. The cause for the noise in the data was mainly due to the low confidence in the selection of points that define edges on the body flap, and the low confidence was caused by the atmospheric haze and soft focus.

A film-to-video conversion was performed on the E-207 and E-212 films for the last three OV-103 missions that were launched at a 57° inclination angle: STS-42, STS-48 and STS-53. A review of each of the films as well as a re-screening of the digital video was conducted to determine whether or not the motion seen was significant. Most of the previous body flap motion studies were performed within the maximum dynamic pressure (Max-Q) region which runs from about 30 to 80 seconds MET. Cloud cover on the STS-53 views after about 28 seconds MET made such a comparison impossible.

2.0 Summary of Significant Events

2.3.6 Orange Flashes in the SRB Plume Prior to SRB Separation (Camera E-207)

Multiple orange flashes were noted in the SRB exhaust plume aft of the vehicle during plume brightening prior to SRB separation. These flashes have occurred on previous Space Shuttle missions. No further photographic analysis has been requested.

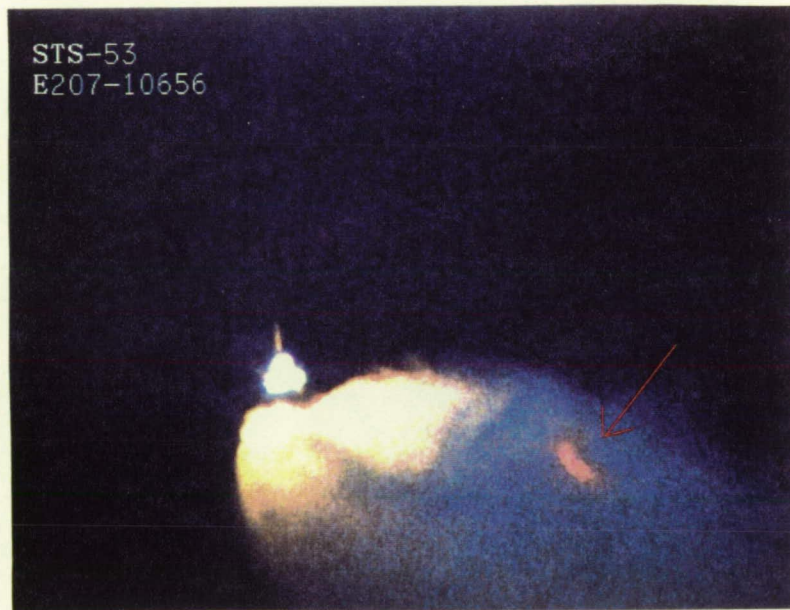

Figure 2.3.6 Flashes in Exhaust Plume Prior to SRB Separation

Figure 2.3.6 shows an orange flash in the exhaust plume prior to SRB separation (arrow). This event was discussed with MSFC personnel who had seen this event on previous flights.

2.4 DTO-0312 Analysis (Task #6) (Magazines STS-53-19 and STS-53-27)

Magazine 19 contained thirty six good quality frames (views) of the external tank taken with a Nikon F4 and a 300 mm lens. The exposure was excellent. ET separation occurred approximately 8:54 MET (13:32:54 UTC). The first picture was acquired at approximately 05 minutes and 32 seconds after ET separation (13:38:26 UTC). The last frame (frame 36) was

2.0 Summary of Significant Events

taken at approximately 8 minutes and 34 seconds after ET separation (13:41:28 UTC). Magazine 27 contained thirty six excellent quality photographs taken with a second Nikon F4 body and the same a 300 mm lens plus an additional the 2X extender. The first frame of the second magazine (roll 27) was taken at approximately 10 minutes and 39 seconds after ET separation (13:43:33 UTC). The last frame was taken at approximately 12 minutes after ET separation (13:44:54 UTC). Overall, the external tank appeared to be in good condition. The normal ET aft dome TPS charring and SRB separation burn scars were observed. Venting from the LH2 umbilical disconnect was observed from frame 53-19-05 through 53-19-18. Two divots were noted on the LH2 intertank interface to the left of the bipod. Three divots were seen on the ET aft dome. Two of the divots were on the -Z side and one was on the +Z side of the external tank (53-19-03).

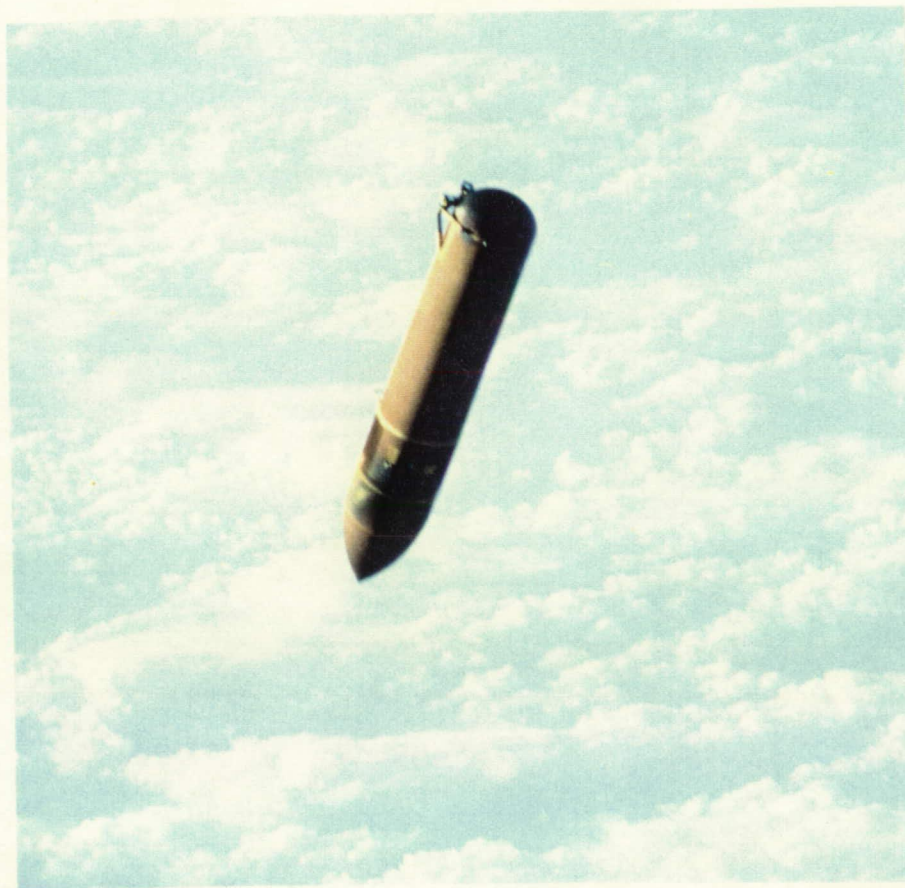

53-019-034

Figure 2.4a View of ET with 300 mm Focal Length

Figure 2.4a shows the left side of the ET, the ET/Orbiter aft attach struts and forward bipod are visible in the FOV. This photograph was taken with the 300 mm focal length lens.



53-027-028

Figure 2.4b View of ET with 300 mm Focal Length Lens with a 2x Extender

Figure 2.4b shows the ET with an effective 600 mm focal length lens. This photograph was taken approximately five minutes after the photograph in Figure 2.4a. This is the first time the long focal length lens has been used in conjunction with DTO-0312.

2.5 Landing Events

2.5.1 Landing Sink Rate Analysis (*Task #3*)

2.5.1.1 Landing Sink Rate Analysis Using Film (*Camera E-1008*)

Camera E-1008 film was used to determine the sink rate of the main gear. The right outboard tire was used to scale the measurements. Data was gathered from approximately 1 second prior to landing through touchdown. Six points on every other frame over a period of 100 frames were digitized. These points consisted of the top and bottom of the rudder speed brake, the top and bottom of the right tire and a point on the top and bottom of the runway immediately beneath the wheel. The raw data was corrected for the vertical change in scale at each frame. The distance

2.0 Summary of Significant Events

between the top of the wheel and the runway surface was computed. A linear regression was applied to the normalized vertical distance versus time data to find the sink rate. The sink rate was determined to be 3.4 feet/second which is within the current threshold limits.

Nose gear touchdown occurred approximately 17 seconds after main gear touchdown. Camera E-1008 was used to determine the nose gear sink rate. The nose wheel itself was used to scale the measurements. Data was gathered for approximately 0.87 second prior to nose gear touchdown. A full second was not used because the control point could not be seen for more than 86 frames. Three points on every other frame over this period were digitized. These points consisted of the top and bottom of the nose wheel and a control point near the edge of the runway. The distance between the bottom of the wheel and the control point was computed and a linear regression was applied in the same manner as the main gear sink rate. This rate was determined to be 1 feet/second which is also well within the current threshold limits.

Graphs depicting the above data can be seen in Appendix D Task #3.

2.5.1.2 Landing Sink Rate Analysis Using Video (Cameras DTV-1, DTV-3)

Cameras DTV-1 and DTV-3 were used to determine sink rate for nose gear and main gear respectively. Data was gathered from approximately 1 second prior to landing through touchdown. Points from thirty-five consecutive video frames from DTV-1 and forty consecutive video frames from DTV-3 were digitized. The following points were digitized for nose gear sink rate: top of speed brake, bottom of speed brake, center of nose gear and the runway directly below the nose gear. For the main gear sink rate the following points were digitized: top of speed brake, bottom of speed brake, center of right main gear, the runway directly below the right main gear, center of the left main gear and the runway directly below the left main gear. The height of the speed brake was used as the scale to determine the actual height of the landing gears above the runway. The sink rate was determined to be 5.4 feet per second for the nose gear and 5.6 feet per second for the right and 6.1 feet per second for the left main gear.

Graphs depicting the above data can be seen in Appendix D Task #3.

2.0 Summary of Significant Events

2.5.2 Drag Chute Performance Analysis (Task #9) (Cameras E-1005, E-1008 and E-1031)

The landing of Discovery at the end of mission STS-53 marked the fifth deployment of the orbiter drag chute. The drag chute initiated 13.981 seconds after main gear touchdown. The drag chute was first measured to be at a heading angle of -7 degrees and a riser angle of +2 degrees. The riser angle changed over a period of 4 seconds from the original +2 degrees to a riser angle of -2 degrees. After disreefing, the drag chute moved further to the vehicle's left side. The heading angle oscillated, having a minimum of -11 degrees before eventually returning to a maximum of +3 degrees. The riser angle had a maximum of +1 degree and a minimum of -10 degrees during the oscillation. The maximum drag chute deflection along the vehicle's y-axis was approximately 21 feet (6.4 meters). The drag chute was released 38.605 seconds after touchdown. At drag chute release, the heading angle was approximately +0.5 degrees and the riser angle was approximately -3.5 degrees. All heading and riser angle measurements are relative to the orbiter's x-axis.

Graphical representation of the data described may be found in Appendix D Task #9.



Figure 2.5.2 Drag Chute Deflection

Figure 2.5.2 shows a view of drag chute at maximum deflection after disreefing and prior to chute release.

2.0 Summary of Significant Events

2.5.3 Post Landing Video Inspection (Camera Walkdown Video)

2.5.3.1 Nitrogen Tetroxide Leak

A reddish brown stain was seen above the F1L forward thruster port. No further photographic analysis has been requested.

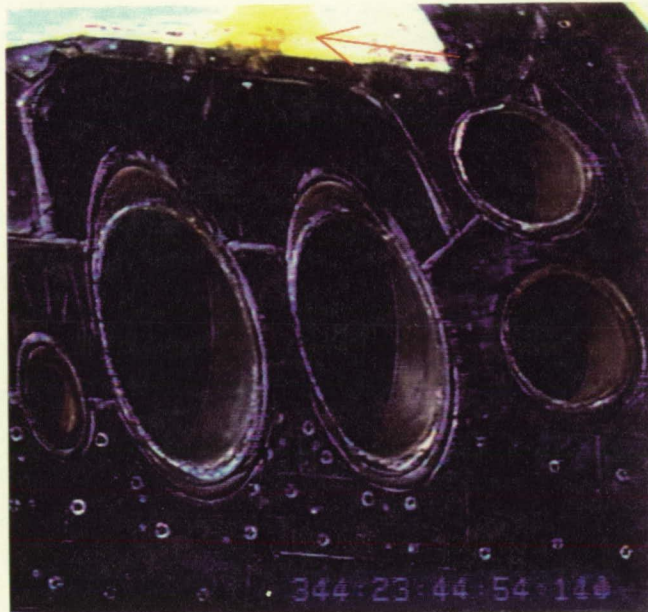

Figure 2.5.3.1 Nitrogen Tetroxide Leak Leaves Discoloration on Orbiter

Figure 2.5.3.1 shows the forward reaction control system (RCS) thrusters. A slight reddish brown stain was seen above and to the right of this port (arrow). This event was noted while still in flight.

2.0 Summary of Significant Events

2.5.3.2 Impact Damage

The post landing debris inspection was conducted by KSC personnel at the mate/demate facility at Dryden Space Center. Two hundred forty hits to the Orbiter TPS were identified of which 23 had major axis greater than one inch as documented on the December 11, 1992, Debris Assessment Report. One hundred forty-five of the two hundred forty strikes were on the Orbiter's lower surface and 11 of these were greater than one inch. No further photographic analysis has been requested.

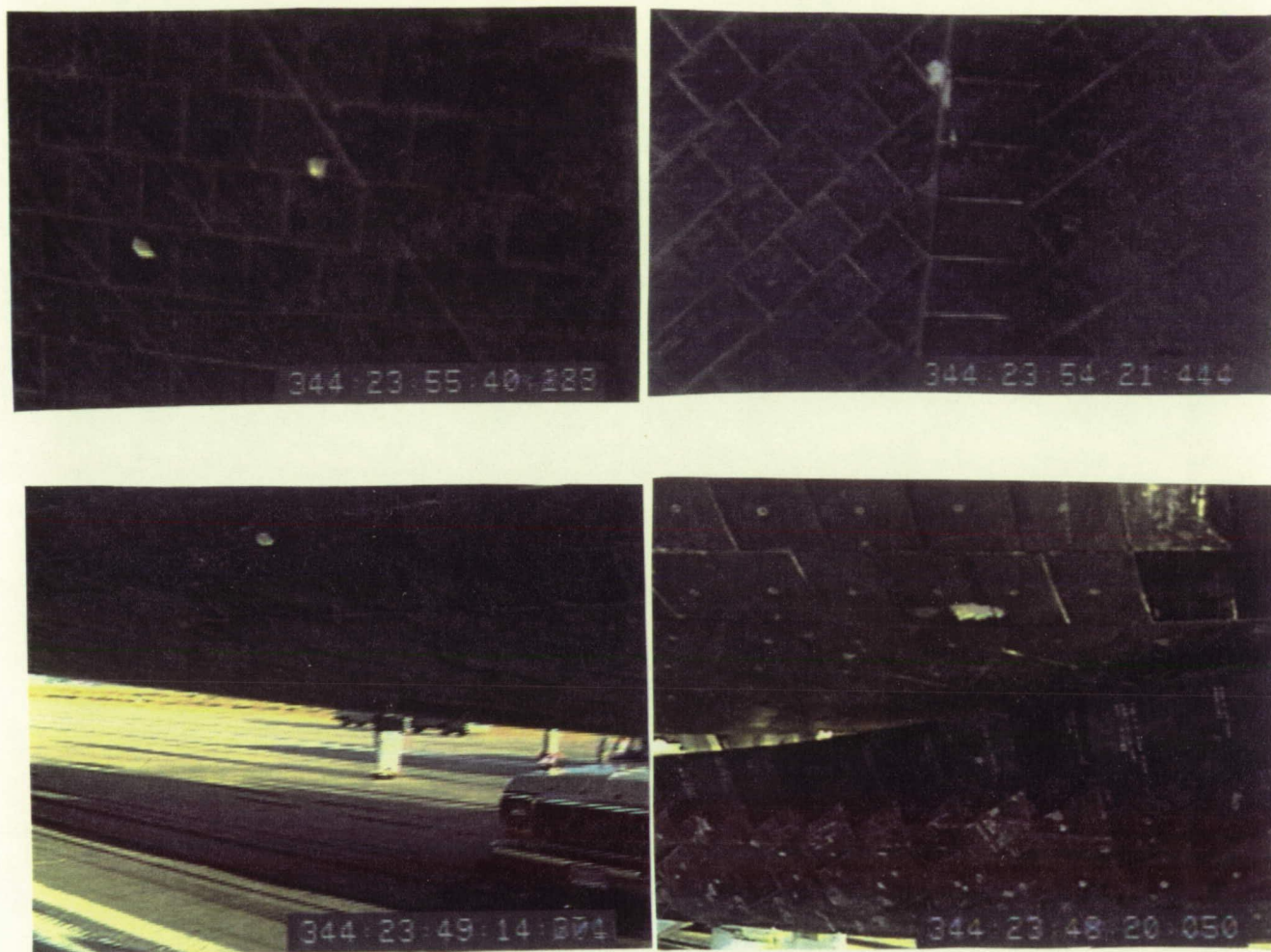

Figure 2.5.3.2a Damage to Lower Surface of the Orbiter TPS

Figure 2.5.3.2a shows examples of minor damage to the underside of the Orbiter's TPS. The damage to the TPS is monitored and mapped after every mission by the KSC debris team. None of the debris strikes observed during the vehicle inspection appeared anomalous.

2.0 Summary of Significant Events

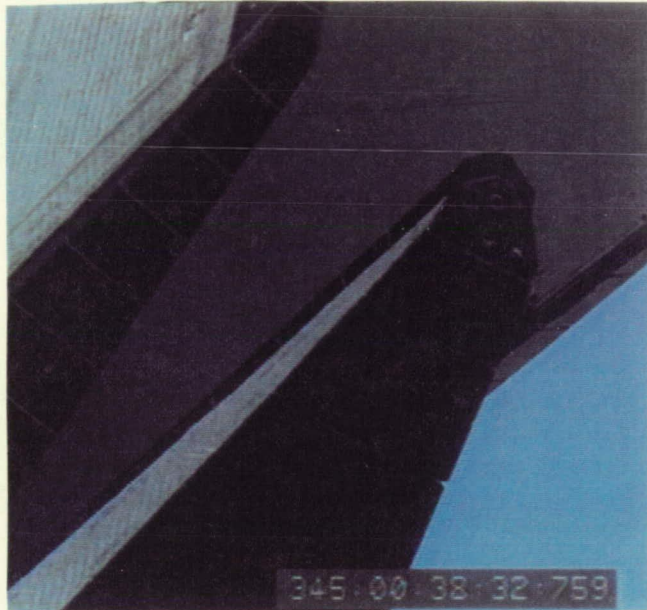

Figure 2.5.3.2b Scarring to the Vertical Stabilizer Stinger

Figure 2.5.3.2b shows two light colored scars to the vertical stabilizer stinger. The location of these scars is near the drag chute door.

2.0 Summary of Significant Events

2.5.3.3 Tear of the Dome Mounted Heat Shield

Damage to the dome mounted heat shield (DMHS) at the two to four o'clock position on SSME #2 was visible. Similar tears have occurred on previous missions. No further photographic analysis has been requested.

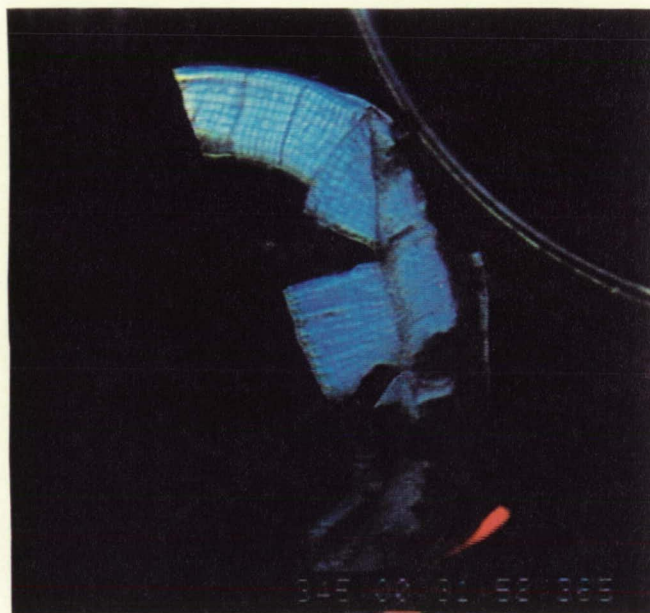

Figure 2.5.3.3 Tear in the DMHS on SSME #2

Figure 2.5.3.3 shows a tear in the DMHS on SSME #M-2. The tear can be seen in about the 3 o'clock position relative to the top of the frame. All of the DMHS appeared normal during the launch film screening.

2.6 Other Events

Other normal events observed include: ice debris and vapor from the ET/Orbiter umbilical disconnects at SSME startup through liftoff; slight vapor from the LO2 vent on the ET, flashes in the SSME plume prior to liftoff; motion of left wing/elevons, the vertical stabilizer, and the body flap between SSME ignition and liftoff; base heat shield erosion during SSME startup; MLP J-pipe water leaks; ice and vapor from both TSM umbilicals at liftoff; debris in the exhaust cloud at the pad after liftoff; RCS paper debris prior to and after liftoff; ET aft dome outgassing and vapor from the SRB stiffener rings after liftoff; charring of the ET aft dome during ascent; debris in the SSME exhaust plume from liftoff through the roll maneuver; flares in the SSME exhaust plume after the roll maneuver; expansion waves; linear optical distortion; condensation around the SLV during ascent; dark puff in SRB plume prior to plume brightening; slag debris in the SRB exhaust plume during and after SRB separation.

Appendix B. MSFC Photographic Analysis Summary

George C. Marshall Space Flight Center
Marshall Space Flight Center, Alabama 35812
AC(205)544-2121

by to Attn of: EP53 (92-129)

TO: Distribution
FROM: EP53/Tom Rieckhoff
SUBJECT: Engineering Photographic Analysis Report for STS-53

Enclosed is the Engineering Photographic Analysis Report for the Space Shuttle Mission STS-53. For additional copies, or for further information concerning this report, contact Tom Rieckhoff at 544-7677, or Darlene Busing, Rockwell at 971-3174.

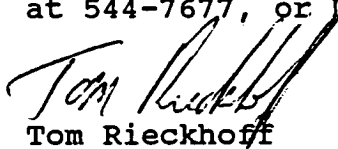

Tom Rieckhoff

Enclosure



National Aeronautics and
Space Administration

George C. Marshall Space Flight Center
Marshall Space Flight Center, Alabama 35812

SPACE SHUTTLE
ENGINEERING PHOTOGRAPHIC ANALYSIS REPORT
STS-53

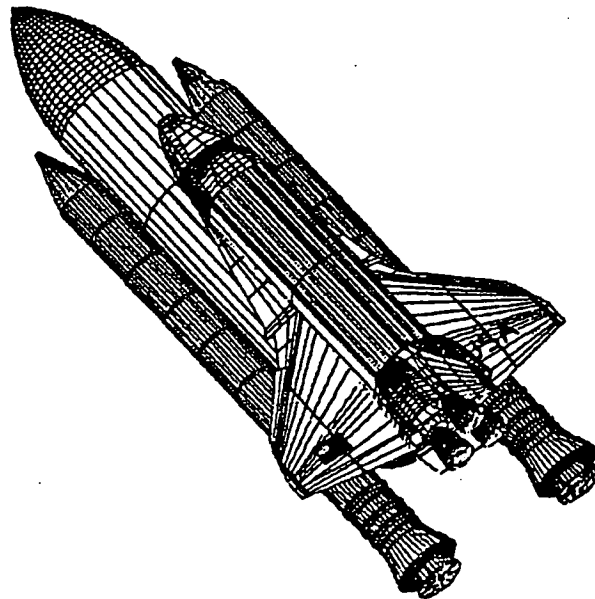

ENGINEERING PHOTOGRAPHIC ANALYSIS REPORT

STS-53

FINAL

PREPARED BY:

D. BUSING, J. HIXSON, B. VIGER
PHOTOGRAPHIC ANALYSIS/ROCKWELL/HSV

SUBMITTED BY:



JIM ULM

SUPERVISOR, LAUNCH OPERATIONS/ROCKWELL/HSV

APPROVED BY:



T. RIECKHOFF, MSFC/EP53

B. LINDLEY-ANDERSON, MSFC/EP53

STS-53 ENGINEERING PHOTOGRAPHIC ANALYSIS REPORT

TABLE OF CONTENTS

- I. INTRODUCTION
- II. ENGINEERING ANALYSIS OBJECTIVES
- III. CAMERA COVERAGE ASSESSMENT
 - A. GROUND CAMERA COVERAGE
 - B. ONBOARD CAMERA COVERAGE
- IV. ANOMALIES/OBSERVATIONS
 - A. GENERAL OBSERVATIONS
 - B. LOOSE THERMAL CURTAIN TAPE
 - C. HOLDDOWN POST M-1 STUD HANG UP
 - D. FLAME NOTED ON SSME #2
 - E. RSRB BSM MOTOR COVER DAMAGE
- V. ENGINEERING DATA RESULTS
 - A. T-0 TIMES
 - B. ET TIP DEFLECTION
 - C. SRB SEPARATION TIME

APPENDIX A - FIGURES

APPENDIX B - INDIVIDUAL FILM CAMERA ASSESSMENT *

APPENDIX C - INDIVIDUAL VIDEO CAMERA ASSESSMENT *

* Photographs in the individual camera assessments are representative photographs and are not necessarily photographs taken from this particular launch.

January 11, 1993

I. INTRODUCTION

Space Shuttle Mission STS-53, the flight of the Orbiter Discovery was conducted December 2, 1992 at approximately 7:24 A.M. Central Standard Time from Launch Complex 39A (LC-39A), Kennedy Space Center (KSC), Florida. Extensive photographic and video coverage was provided and has been evaluated to determine proper operation of the ground and flight hardware. Cameras (video and cine) providing this coverage are located on the fixed service structure (FSS), mobile launch platform (MLP), LC-39A perimeter sites, onboard, and uprange and downrange tracking sites.

II. ENGINEERING ANALYSIS OBJECTIVES:

The planned engineering photographic and video analysis objectives for STS-53 included, but were not limited to the following.

- a. Overall facility and Shuttle vehicle coverage for anomaly detection
- b. Verification of cameras, lighting and timing systems
- c. Determination of SRB PIC firing time and SRB separation time
- d. Verification of Thermal Protection System (TPS) integrity
- e. Correct operation of the following:
 1. Holddown post blast covers
 2. SSME ignition
 3. LH2 and LO2 17" disconnects
 4. GH2 umbilical
 5. TSM carrier plate umbilicals
 6. Free hydrogen ignitors
 7. Vehicle clearances
 8. GH2 vent line retraction and latch back
 9. Vehicle motion

There was one special test objective for this mission.

- a. DTO-0312, ET photography after separation

III. CAMERA COVERAGE ASSESSMENT:

Film was received from fifty-two of fifty-five requested cameras as well as video from twenty-three of twenty-four requested cameras. The following table illustrates the camera data received at MSFC for STS-53.

CAMERA DATA RECEIVED FOR STS-53

	<u>16mm</u>	<u>35mm</u>	<u>Video</u>
MLP	22	0	4
FSS	6	0	2
Perimeter	3	3	6
Tracking	0	16	11
Onboard	2	0	0
Totals	33	19	23

A detailed individual motion picture camera assessment is provided as Appendix B. Appendix C contains detailed assessments of the video products received at MSFC.

a. Ground Camera Coverage:

Photographic coverage of STS-53 was considered good. Coverage from some tracking cameras was limited due to cloud coverage. Camera E-35 did not run due to a mechanical problem. Video camera OTV-009 was not received at MSFC due to a local communications problem.

Timing was not recorded, at MSFC, on several of the launch playback videos. This failure occurs frequently and is an operational error.

b. Onboard Camera Assessment:

A camera was flown on each SRB forward skirt to record the main parachute deployment. Both cameras operated properly, with the exception that neither camera recorded water impact. The astronauts carried two 35mm hand-held cameras, one of which had a 2X extender to record film for evaluating the ET TPS integrity after ET separation. These films will be reviewed at a later date due to delays caused by this being an classified DOD mission. Upon request, information from these films will be available.

IV. ANOMALIES/OBSERVATIONS:

a. General Observations:

While viewing the film, several events were noted which occur on most missions. These included: pad debris rising and falling as the vehicle lifts off; debris induced streaks in the

SSME plume; ice falling from the 17" disconnects and umbilicals; and debris particles falling aft of the vehicle during ascent, which consist of RCS motor covers, hydrogen fire detectors and purge barrier material.

b. Loose Thermal Curtain Tape:

Figure one is a frame of film from camera E-7. This figure shows one large piece of loose thermal curtain tape on the right SRB.

c. Holddown Post M-1 Stud Hang Up:

Figure two is a frame of film taken from camera E-9 showing holddown post M-1 stud hang up. The shoe lifts with the vehicle as it rises. The stud remains fully extended until the SRB aft skirt clears the post then falls into the hold catcher.

d. Flame Noted on SSME #2:

Figures three and four are frames of film from cameras E-16 and E-18 showing a flame that was noted on the nozzle of SSME #2 originating at the #2 fuel line at or near the steerhorn. The flame first appeared as the number two engine reached mainstage and continued to burn as the vehicle left the field of view. The flame is thought to be a result of possible leak in the #2 steerhorn.

e. RSRB BSM Motor Cover Damage:

Post-flight inspection of the RSRB aft BSM motor cover showed a debris impact approximately 3 inches long and 0.5 inches deep with fragments of Orbiter tile. A re-review of films was performed with emphasis being placed on the aft BSM motor cover. This review showed no evidence of a debris impact. Film coverage of the BSM motor is considered good through the roll maneuver. However, after the roll maneuver, film coverage may be inadequate to record such a debris impact.

V. ENGINEERING DATA RESULTS:

a. T-Zero Times:

T-Zero times were determined from cameras which view the SRB holddown posts numbers M-1, M-2, M-5 and M-6. These cameras record the explosive bolt combustion products.

POST	CAMERA POSITION	TIME (UTC)
M-1	E-9	337:13:24:00.003
M-2	E-8	337:13:24:00.002
M-5	E-12	337:13:24:00.001
M-6	E-13	337:13:24:00.002

b. ET Tip Deflection:

Maximum ET tip deflection for this mission was determined to be approximately 31.2 inches. Figure five is a data plot showing the measured motion of the ET tip in both the horizontal and vertical directions. These data were derived from camera E-79.

c. SRB Separation Time:

SRB separation time for STS-52 was determined to be 337:13:26:06.40 UTC taken from camera E-207.

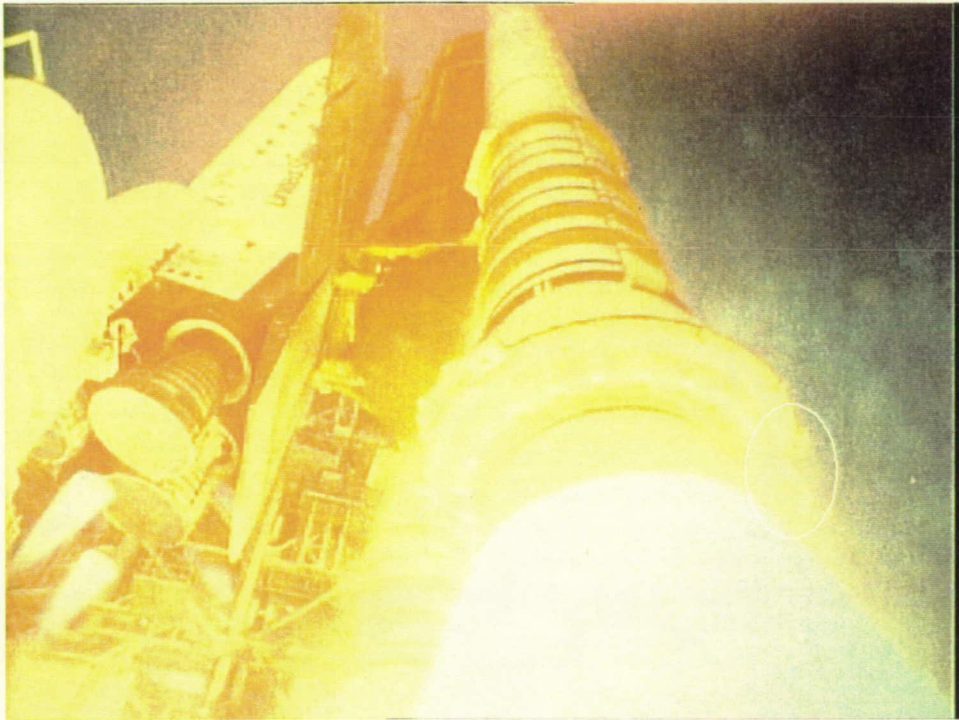

Figure 1
Loose Piece of Thermal Curtain Tape

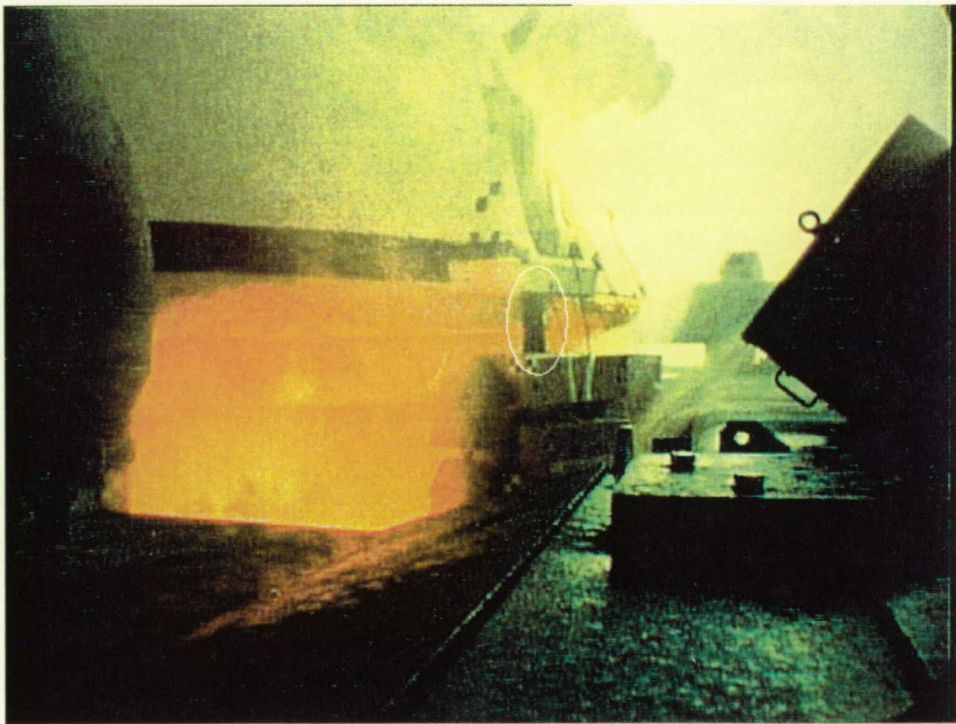

Figure 2
Holddown Post M-1 Stud Hang Up

ORIGINAL PAGE
COLOR PHOTOGRAPH

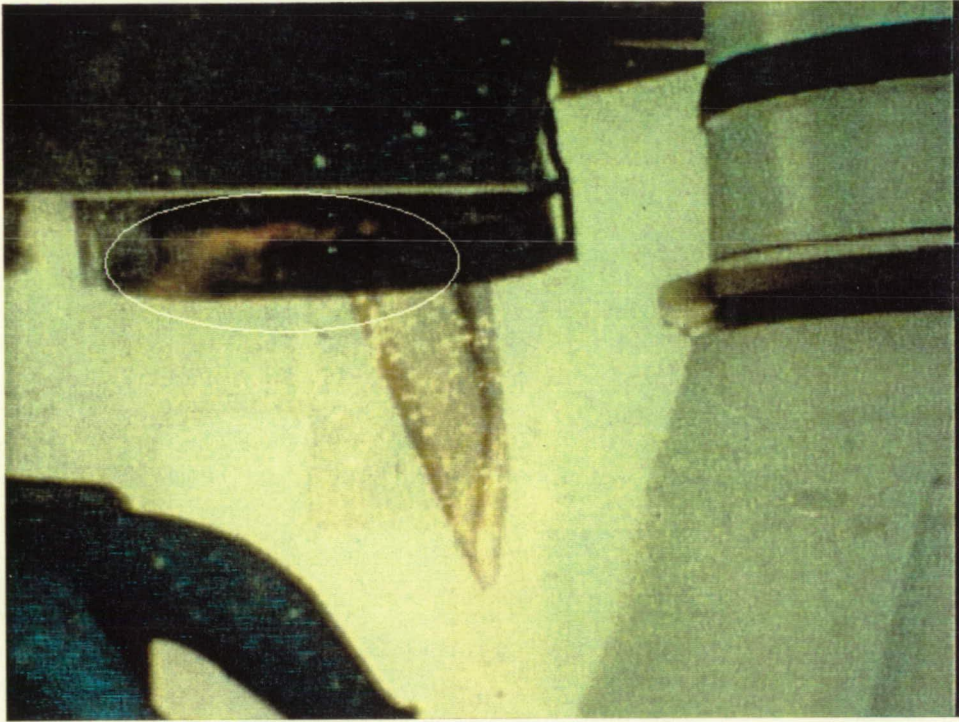

Figure 3

Flame Noted on SSME #2, Camera E-16



Figure 4

ORIGINAL PAGE
COLOR PHOTOGRAPH

Flame Noted on SSME #2, Camera E-18

ET TIP DEFLECTION

STS-53

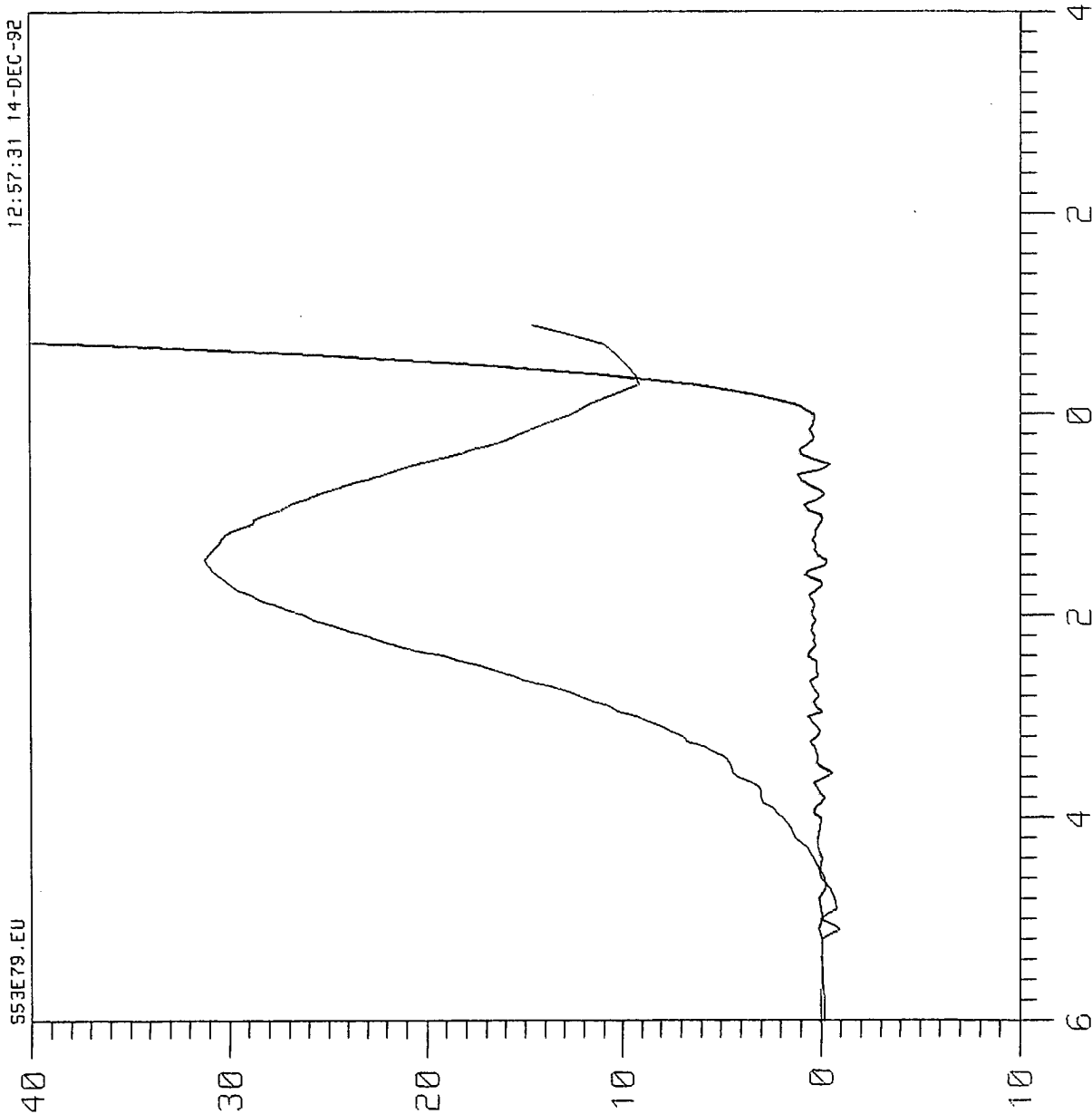

— HORZ MOTION

- - - VERT MOTION

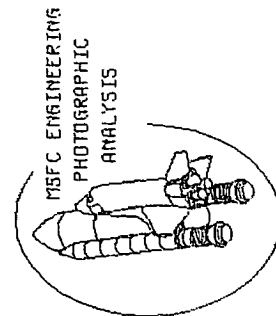

(INCHES) MOTION

Figure 5

Appendix C. Rockwell Photographic Analysis Summary

Space Transportation Systems Division
Rockwell International Corporation
12214 Lakewood Boulevard
Downey, California 90241



Rockwell
International

January 26, 1993

In Reply Refer to 93MA0068

National Aeronautics and Space Administration
Lyndon B. Johnson Space Center
Houston, Texas 77058

Attention: L. G. Williams (WA)

Contract NAS9-18500, System Integration, Transmittal of the Rockwell
Engineering Photographic Analysis Report for the STS-53 Mission.

The System Integration Contractor hereby submits the Engineering
Photographic Analysis Summary Report in accordance with the Space Shuttle
Program Launch and Landing Photographic Engineering Evaluation Document
(NSTS 08244).

Extensive photographic and video coverage was provided and has been evaluated
to determine ground and flight performance. Cameras (cine and video)
providing this coverage are located on the Launch Complex 39A Fixed Service
Structure (FSS), Mobile Launch Platform (MLP), various perimeter sites, and
uprange and downrange tracking sites for the STS-53 launch conducted on
December 2, 1992, at approximately 5:24 AM (PST) from the Kennedy Space
Center (KSC) and for the landing on December 9, 1992 at Edwards Airforce Base
(12:44 PM PST).

Rockwell received launch films from 83 cameras (59 cine, 24 video) and landing
films from 16 cameras (10 cine, 6 video) to support the STS-53 photographic
evaluation effort. One film, E-35 was not available due to camera malfunction.

All ground camera coverage for this mission including coverage on the MLP,
FSS and tracking cameras were good.

Overall, the films showed STS-53 to be a clean flight. Several pieces of ice from
the ET/ORB umbilicals were shaken loose at SSME ignition, but no damage to
the Orbiter Thermal Protection System (TPS) was apparent. The usual
condensation and water vapors were seen at the ET aft dome and the SRB
stiffener rings and dissipated after the completion of the roll maneuver. Vapor
was observed originating from the drain hole on the aft edge of the rudder/speed
brake at liftoff. Charring of the ET aft dome and recirculation and brightening of
the SRB plumes were visible and normal. Booster Separation Motor (BSM) firing
and SRB separation also appeared to be normal.

(Packing Sheet No. DM93-07904)

A disturbance in the lateral acceleration strip chart data at liftoff led Rockwell Engineers (Ascent Separation Systems) to suspect there had been a bolt hang-up on one of the SRB holddown support posts. This assumption was confirmed when film E-9 was reviewed which clearly showed the post M-1 bolt to hang-up at liftoff. The bolt also deflected during liftoff until the aft skirt foot rose sufficiently to release it, causing the bolt to spring back to its original vertical position.

Nominal performance was seen for the MLP and FSS hardware. FSS deluge water was activated prior to SSME ignition and the MLP rainbirds were activated at approximately 1 second Mission Elapsed Time (MET), as is normal. All blast deflection shields closed prior to direct SRB exhaust plume impingement. Both TSM umbilicals released and retracted as designed. The ET GH2 vent line carrier dropped normally and latched securely with no rebound. No anomalies were identified with the ET/ORB LH2 umbilical hydrogen dispersal system hardware.

STS-53 was the twelfth flight with the optimized attach link in the SRB holddown support post Debris Containment Systems (DCS's). The link is designed to increase the plunger velocity and seating accuracy, while leaving the holddown bolt ejection velocity unchanged. This prevents frangible nut fragments and/or NSI cartridges from falling from the DCS, while not increasing the probability of a holddown bolt hang-up. However, during the review of the holddown post films for this mission, a single piece of (dark) debris was observed originating from the DCS area at liftoff.

Significant events that were observed include a bolt hang-up at holddown post M-1 at liftoff and the orange vapor at the #9 hat band on SSME #2 which may indicate a leak in that area. Also, a potential problem was discovered during the post SRB recovery inspection, when Orbiter tile fragments were found embedded in the right hand aft BSM cover. This resulted in launch films, that showed the right hand SRB aft skirt area, being re-screened for assessment of potential Orbiter tile damage and Orbiter re-entry risk. These events and other events noted by the Rockwell film/video users during the review and analysis of the STS-53 photographic items are summarized in the following comments. These events are not considered to be a constraint to next flight.

COMMENTS

1. A hangup of the holddown post M-1 holddown bolt on the right SRB was seen at liftoff on camera E-9. Rockwell/Downey engineers had previously reported a disturbance in the lateral acceleration strip chart data at liftoff which led them to expect a possible holddown post bolt hangup. This event was clearly seen in the photographic review as the M-1 holddown bolt rose a significant amount during liftoff before breaking away from the SRB and springing back into position. Bolt hangups have occurred on previous flights since return to flight. No further analysis is planned.
2. On cameras E-5 and E-6, E-20 an orange vapor (burning hydrogen) was visible between the exit plane and the #9 hat band near the nozzle steer horn on SSME #2. This event is similar to the hydrogen leak observed during SSME #2 ignition for STS-44 and is probably a nozzle cold wall tube leak.

The engine is currently scheduled to be removed the first week of February for leak checks by Rocketdyne at KSC. No follow-up action is planned.

3. The post SRB recovery inspection of the right SRB revealed damage (thin "crescent" shaped "gash" approximately 3 in. x 1/8 in. x 1/2 in. deep) to the cork TPS material on the right-hand aft cover of the center BSM. The damaged site TPS material was removed and sent to United Space Booster, Incorporated (USBI) for laboratory analysis. The analysis indicated the debris was dark gray to black with three faint, light green circular dots and white fibrous material on the opposite side. The green dots are consistent with Orbiter Original Equipment Manufacturer (OEM) identification markings. The chemical content was predominantly silica, indicating Orbiter TPS tile material. Based on this analysis, on December 8th at 16:15 PST, the evening before the STS-53 landing, the debris assessment teams at JSC, MSFC, KSC and RI Downey were activated in order to locate the source of the debris. The launch films that showed the RSRB aft skirt area were re-screened for indications of debris that may have been related to the Orbiter tile fragments found embedded in the right-hand aft BSM cover. The source that caused the BSM cover damage could not be determined from the launch films. However, the Rockwell team created a briefing which described the problem, the material analysis identifying the debris as Orbiter tile material, past history regarding re-entry heating on damaged TPS, the zone from which the tile fragments could have come, the critical components underneath the damaged area, and Rockwells' assessment of the re-entry risk. This briefing was presented to the NASA Management Council at 6 AM on December 9. Their decision was to continue the flight with the re-entry as planned.

The subsequent post-flight inspection of OV-103 showed the type of damage that the Rockwell team had predicted, with no apparent damage to the underlying aluminum skin material. No follow-up photographic analysis has been requested.

4. On camera E-8 a single dark piece of debris was seen near the DCS area of holddown post M-2 at liftoff. No further analysis is planned.
5. Orange vapor (possibly free burning hydrogen) was seen below SSME's just prior to SSME ignition on cameras OTV-070, OTV-071, E-19, E-36, E-77 and beneath the body flap (moving north) on camera OTV-063. This vapor appears to be similar to the vapor noted on previous missions. It is not an issue and no follow-up action is planned.
6. On camera E-7, E-15 and E-25, a piece of loose thermal curtain tape was noted on the right SRB aft skirt near holddown post M-4 prior to liftoff. Loose thermal curtain tape has been seen on previous missions. No follow-up action is planned.
7. Vapor was observed trailing from the drain hole on the aft edge of the rudder/speed brake after liftoff on cameras E-34, E-40 and E-52. Vapor from the drain hole on the rudder/speed brake has been seen on previous missions. No follow-up action is planned.

8. On cameras OTV-009, E-1, E-4, E-5, E-6, E-14, E-16, E-18, E-25, E-30, E-34, E-36, E-65 and E-77, multiple pieces of white debris (probably ice) were seen falling from the ET/Orbiter umbilicals at SSME ignition. Several of these particles contacted the lower edge of the umbilical door, but no damage was detected. No follow-up analysis is planned.
9. Multiple pieces of ice/frost were seen falling from the ET LO2 feedline forward bellows and support bracket area at liftoff on camera E-54. None of the debris appeared to strike the vehicle. No follow-up action is planned.
10. On cameras E-17 and E-19, a light colored, rectangular piece of debris was noted in the LO2 TSM carrier plate area falling aft prior to liftoff. Also, a red, rectangular piece of debris was seen falling aft from the LO2 TSM feed line area prior to liftoff. No follow-up action is planned.
11. On camera E-62, four dark debris objects (probably SRB throat plug RTV) appeared to be moving north out of the SRB flame trench. This debris did not appear to strike the vehicle. No follow-up action is planned.
12. Flares and flashes seen in the SSME exhaust plume (E-54, E-207, E-213) during ascent. These observations have been seen in the SSME plumes on previous missions and are understood to be burning of propellant impurities including RCS paper covers. No follow-up action is planned.
13. On cameras E-207 and E-223, dark puffs were noted in the SRB plume at approximately 114 seconds MET (prior to plume brightening). Dark puffs have been seen on previous missions and no follow-up action is planned.
14. The following events have been reported on previous missions and observed on STS-53. These are not of major concern, but are documented here for information only:
 - Ice debris falling from the ET/Orbiter Umbilical disconnect area.
 - Debris (Pad, insta-foam, water trough) in the holddown post areas and MLP.
 - Butcher paper falling from the RCS.
 - Recirculation or expansion of burning gases at the aft end of the SLV prior to SRB separation.
 - Slight TPS erosion on the base heat shield during SSME start-up.
 - Debris pieces in the SSME/SRB plumes.
 - ET aft dome outgassing and charring.
 - Slight elevon motion at SSME ignition.
 - Twang motion.
 - Body flap motion during the maximum dynamic pressure (MAX-Q) region which appeared to have an amplitude and frequency similar to those of previous missions.
 - Linear optical distortion, possibly caused by shock waves or ambient meteorological conditions near the vehicle, during ascent.
 - Slag in SRB plume after separation.
 - Condensation around the SLV during ascent.
 - Vapor from the SRB stiffener rings after liftoff.

15. Cameras E33 and E41 - OMRSD File IX Vol. 5, Requirement No. DV08P.010 requires an analysis of launch pad film data to verify that the initial ascent clearance separation between the left SRB outer mold line and the falling ET vent umbilical structure does not violate the acceptable margin of safety.

A qualitative assessment has been conducted and positive clearances between the left SRB and the ET vent umbilical have been verified. The films showed nominal launch pad hardware performance, and no anomalies were observed for the SRB body trajectory.

16. Cameras E7-16 and E27-E28 - OMRSD File IX Vol. 5, Requirement No. DV08P.020 requires an analysis of film data of SRM nozzle during liftoff to verify nozzle to holddown post drift clearance.

A qualitative assessment of the launch films has been completed. No anomalies were observed for the SRM nozzle trajectory and positive clearances between the SRB nozzles and the holddown posts were verified.

17. The landing of STS-53 occurred on the hard surface runway 22 at Edwards Air Force Base. Good video and film coverage were obtained and no anomalous events were observed. This flight marked the fifth use of the Orbiter drag chute. The drag parachute system performed as expected. All sequenced events occurred as expected and no hardware anomalies were observed. The drag chute appeared to drift to the left of the Orbiter center line as the vehicle slows down.

Analysis continues in the areas of compartment door trajectory, reeled main chute operation, and riser position relative to the Orbiter stinger. The results of this analysis will be used to validate models against actual flight data, and to allow accurate predictions for future flights.

This letter is of particular interest to W. J. Gaylor (VF2) and J. M. Stearns (WE3) at JSC. The Integration Contractor contact is R. Ramon at (310) 922-3679.

ROCKWELL INTERNATIONAL
Space Systems Division



J. A. Wolfelt
Chief Engineer
System Integration

RR:cl

REPORT DOCUMENTATION PAGE

Form Approved
OMB No. 0704-0188

Public reporting burden for this collection of information is estimated to average 1 hour per response, including the time for reviewing instructions, searching existing data sources, gathering and maintaining the data needed, and completing and reviewing the collection of information. Send comments regarding this burden estimate or any other aspect of this collection of information, including suggestions for reducing this burden, to Washington Headquarters Services, Directorate for Information Operations and Reports, 1215 Jefferson Davis Highway, Suite 1204, Arlington, VA 22202-4302, and to the Office of Management and Budget, Paperwork Reduction Project (0704-0188), Washington, DC 20503.

1. AGENCY USE ONLY (Leave blank)	2. REPORT DATE January 1993	3. REPORT TYPE AND DATES COVERED Final 1-11 December 1992
----------------------------------	--------------------------------	--

4. TITLE AND SUBTITLE Debris/Ice/TPS Assessment and Integrated Photographic Analysis of Shuttle Mission STS-53	5. FUNDING NUMBERS
---	--------------------

6. AUTHOR(S) Gregory N. Katnik Scott A. Higginbotham J. Bradley Davis	5. FUNDING NUMBERS
--	--------------------

7. PERFORMING ORGANIZATION NAME(S) AND ADDRESS(ES) NASA External Tank Mechanical Systems Division Mail Code: TV-MSD-22 Kennedy Space Center, Florida 32899	8. PERFORMING ORGANIZATION REPORT NUMBER TM 107556
---	---

9. SPONSORING/MONITORING AGENCY NAME(S) AND ADDRESS(ES)	10. SPONSORING/MONITORING AGENCY REPORT NUMBER
---	--

11. SUPPLEMENTARY NOTES

12a. DISTRIBUTION/AVAILABILITY STATEMENT Publicly Available Unclassified - Unlimited	12b. DISTRIBUTION CODE
--	------------------------

13. ABSTRACT (Maximum 200 words)

A Debris/Ice/TPS assessment and integrated photographic analysis was conducted for Shuttle Mission STS-53. Debris inspections of the flight elements and launch pad were performed before and after launch. Ice/Frost conditions on the External Tank were assessed by the use of computer programs, nomographs, and infrared scanner data during cryogenic loading of the vehicle followed by on-pad visual inspection. High speed photography was analyzed after launch to identify ice/debris sources and evaluate potential vehicle damage and/or in-flight anomalies. This report documents the debris/ice/TPS conditions and integrated photographic analysis of Shuttle Mission STS-53, and the resulting effect on the Space Shuttle Program.

14. SUBJECT TERMS STS-53 Ice Frost Debris Thermal Protection System (TPS) Photographic Analysis	15. NUMBER OF PAGES
	16. PRICE CODE

17. SECURITY CLASSIFICATION OF REPORT Unclassified	18. SECURITY CLASSIFICATION OF THIS PAGE Unclassified	19. SECURITY CLASSIFICATION OF ABSTRACT Unclassified	20. LIMITATION OF ABSTRACT Unlimited
---	--	---	---

KSC DEBRIS/ICE/TPS ASSESSMENT AND INTEGRATED PHOTOGRAPHIC
ANALYSIS REPORT DISTRIBUTION LIST 6/92

NASA - KSC

MK/B. Shaw
TV-PEO-2/P. Weber
TV-MSD-1/C. Stevenson
TV-MSD-2/L. Bolton
TV-MSD-22/G. Katnik (9)
TE-CID-2/C. Brown
TE-CID-21A/N. Pope
RO/R. E. Reyes
MK-SIO-2/C. Martin

GK-5/Z. H. Byrns
SK/F. Huneidi
ZK-88/K. J. Mayer
LSO-178/H. L. Lamberth
LSO-437/J. Cawby
USBI-LSS/L. Clark
BICO-1/R. B. Hoover

NASA - HQ

QSO/W. Comer

NASA - JSC

VA/D. Germany
WE3/G. I. Good
ES3/J. Kowal
SN3/E. Christiansen
SN5/D. E. Pitts

Johnson Space Center
Houston, Texas 77058

NASA - MSFC

ED35/D. Andrews
EE31/M. A. Pessin
EP55/T. J. Rieckhoff
SA32/J. G. Cavalaris
SA31/G. C. Ladner

Marshall Space Flight
Center
Huntsville, AL 35812

Rockwell - Downey

AC07/J. McClymonds
FA44/R. Ramon

Rockwell International
12214 Lakewood Blvd
Downey, CA 90241

Martin Marietta

Dept. 3571/S. Copsey
Dept. 3570/C. Gray

13800 Old Gentilly Road
New Orleans, Louisiana
70129
P. O. Box 29304
New Orleans, Louisiana
70189