

N93-25598

537-33
150507

P. 8

HIGH SPEED SOLID STATE CIRCUIT BREAKER

Thomas F. Podlesak
Electronics Engineer

U.S. Army Research Laboratory, Electronics and Power Sources
Directorate

Pulse Power Components Branch
ATTN: AMSRL-EP-MC(Podlesak)
Fort Monmouth, NJ 07703-5601

ABSTRACT

The U.S. Army Research Laboratory, Fort Monmouth, NJ, has developed and is installing two 3.3 MW high speed solid state circuit breakers at the Army's Pulse Power Center. These circuit breakers will interrupt 4160V three phase power mains in no more than 300 microseconds, two orders of magnitude faster than conventional mechanical contact type circuit breakers. These circuit breakers utilize Gate Turnoff Thyristors (GTOs) and are currently utility type devices using air cooling in an air conditioned enclosure. Future refinements include liquid cooling, either water or two phase organic coolant, and more advanced semiconductors. Each of these refinements promises a more compact, more reliable unit.

INTRODUCTION

The U.S. Army Pulse Power Center, located at Fort Monmouth, NJ, has the unique mission of performing research, development and benchmark testing of megawatt class power components and subsystems. The Center, shown in Figure 1, has an installed continuous capability of 30 MVA, continuous liquid cooling of 10 Megawatts and is shielded to the DoD TEMPEST standard. This facility is ideally suited to the stressing of high powered components to the limits of their ability.

When subjected to the extreme conditions of benchmark testing, components and subsystems are very likely to undergo a fault condition. The amount of available power makes the destruction of the component under these conditions very probable. The incident rate of component destruction, which can be hazardous to equipment and personnel, is high. In the past, the component under test was protected by standard, mechanical, utility circuit breakers, which clear in tens of milliseconds. This length of time, although considered very short under normal conditions, can be an eternity under dangerous fault conditions. It was therefore determined that a faster fault protection device was needed.



Figure 1: The U.S. Army Pulse Power Center at Fort Monmouth, NJ

The decision was made to install a solid state based circuit breaker in the 4160 Volt utility mains leading into the Pulse Power Center's dual 3.3 Megawatt power supply. This supply consists of two independent 3.3 Megawatt power supplies, which may operated together to form one 6.6 Megawatt power supply. This a most versatile unit and is used extensively for experiments at the Pulse Power Center. As part of its ongoing mission in high power components, extensive work has be done at the Pulse Power Center in the area of high power solid state switching. A series of experiments established the applicability of operating Gate Turnoff Thyristors (GTOs) in series to produce a repetitive opening and closing switch, capable of operating at voltages that were much in excess of the rating of an individual device. Additional experimental work has been conducted utilizing more advanced semiconductors, which promise more efficient operation. The knowledge of the capabilities of these devices lead to the conception of a solid state circuit breaker for power applications, with the key requirement that the interrupt time be less than 300 microseconds, two orders of magnitude better than existing mechanical circuit breaker. There is also the advantage of no mechanical degradation of the solid state circuit breaker, since moving parts have been eliminated and arcing is not present.

THE INSTALLATION OF THE SOLID STATE CIRCUIT BREAKERS

The installation of the solid state circuit breaker and associated control circuitry was authorized in 1989, under the

Productivity and Capital Improvement Program (PCIP). This is a program within the Department of Defense to improve productivity at its facilities by means of the installation of advanced equipment. The reasoning was that so much would be saved in time and material by preventing destruction of components under test that the project would easily justify the its expense, this pay back being a requirement of the program.

The specifications for the solid state circuit breaker are presented in Table I. Upon release of the specifications, the Westinghouse Science and Technology Center, Pittsburgh, PA, bid and was awarded the contract to design and manufacture two such units, one for each of the two 3.3 Megawatt power supplies. The units are illustrated in Figure 2. Note the three individual structures, one for each phase of the power circuit. The units use four GTOs per polarity per phase, resulting in twenty-four GTOs per units. The Pulse Power Center is heavily committed to preserving the technical manufacturing base in the United States and, therefore insisted on domestic GTOs. The GTOs were manufactured to Westinghouse's specifications by the Static Power Control Operation of General Electric, located at Malvern, PA. The devices are a modification of an existing GE design for 4000 V, 1 KA devices. The modification was to allow a more reliable turnon of the power, which was predicated by the control algorithm adopted by Westinghouse. The GTOs are symmetric. The devices stand approximately 4 feet (1.3 m) high, are approximately 6 feet (1.8 m) long and 2 feet (0.6 m) deep, and weigh approximately 1 ton (900 kg). They are utility units and air cooled, hence the large size and weight.

Table 1

Solid State Circuit Breaker Technical Requirements

Withstand Voltage-Terminals	15 kV
Withstand Voltage to Ground	15 kV
BIL (Basic Impulse Level)	30 kV
Continuous Current	600 A
Maximum Interrupt Current	2 kA
Surge Current (10 ms- 1 cycle)	10 kA
Steady State Switch Impedance	50 mOhms
Closing Time	50 microseconds
Opening Time	300 microseconds
Operating Temperature	0 C to 80 C

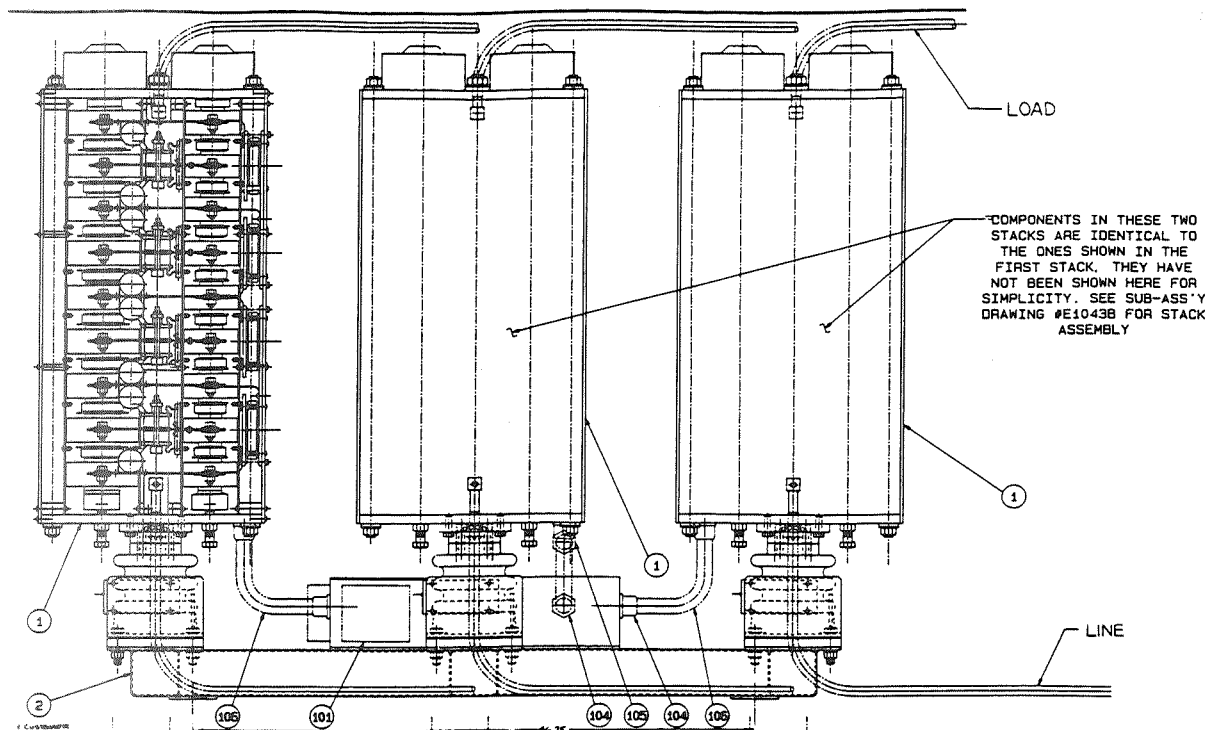

Figure 2: Drawing of the solid state circuit breaker, showing the location of the line and load cables, the control enclosure (rectangular, lower center) and detail of the structure of one phase of the circuit breaker (at left). Specifically, the eight flattened rectangles to the left of the structure are the GTOs, the corresponding eight structures to the right are steering diodes and the components along the centerline constitute the snubbers for the GTO. The unit is approximately six feet long.

The air cooling requirement necessitated a special enclosure for the units. Power handling equipment of this type is normally located outside in a switch yard. The solid state circuit breakers are no exception. They have been installed in a climatically controlled NEMA Class 4 enclosure in the switchyard located behind the Pulse Power Center, in close proximity to the existing equipment that comprise the 6.6 MW power supply. A photograph of the installed units appears as Figure 3. A schematic of the installation is shown in Figure 4. Note the voltage arrestors on both line and load sides of the solid state circuit breaker in the schematic, and which are visible at the right of the photograph. These protect the GTOs from voltage transients, which may occur in closing and opening operations. Saturable core reactors in the line side protect the unit from damage due to the instantaneous application of current. Mechanical contactors are provided on the line side for isolation. Synchronization signals from the phases are detected from the auxiliary power circuit. This is present even if the prime power is not connected. To conclude the discussion on the circuit breaker, there are three control lines, two fiber optics

and one twisted pair. The fiber optics are system enable and the on/off signal. The twisted pair is a relay closure, confirming circuit breaker closure. The signal leaves the circuit breaker over twisted pair, but is converted to fiber optic, as are all control signals on all power supplies at the Pulse Power Center.

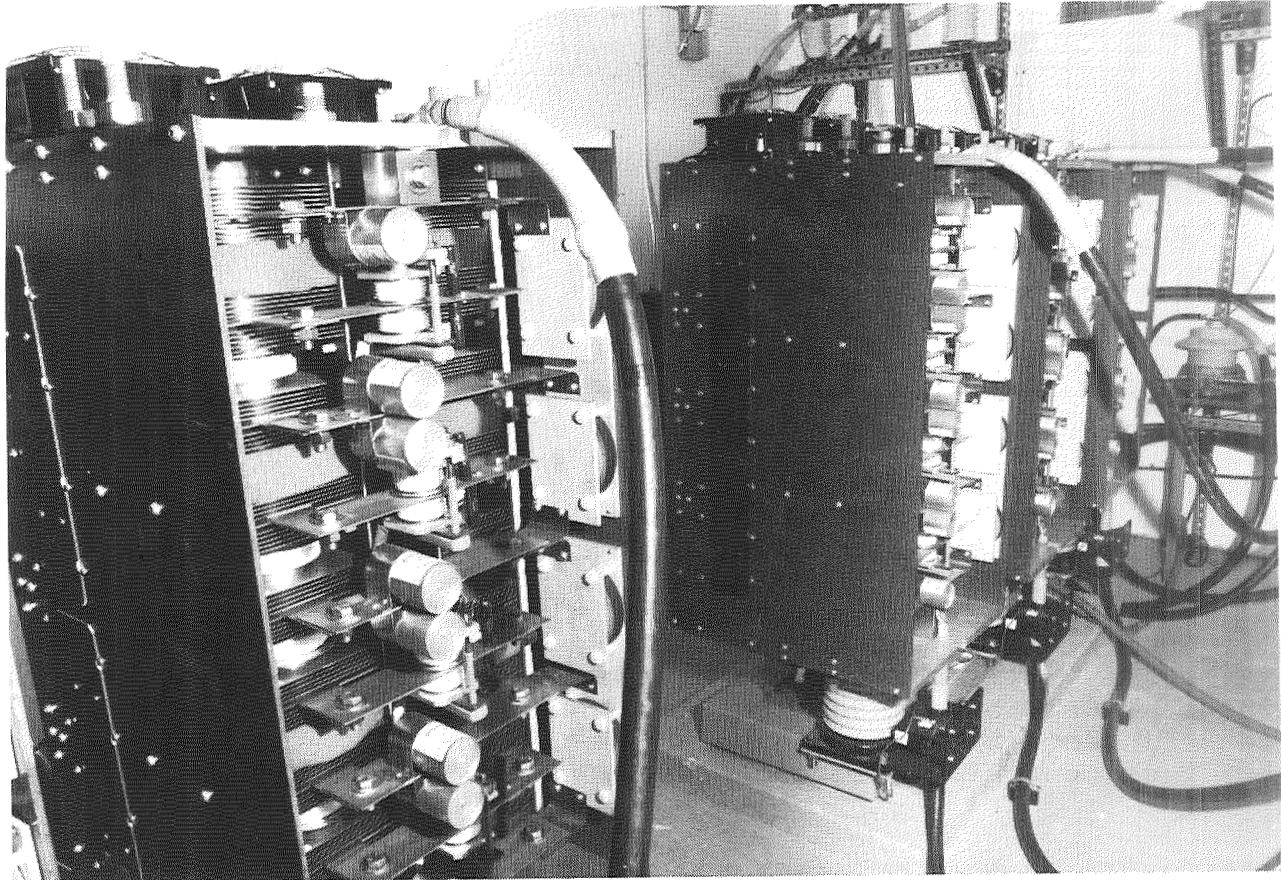

Figure 3. The solid state circuit breakers installed at Fort Monmouth. The phase section at the left clearly shows the snubber components along the vertical centerline, with the GTOs (white structures) to their left. One voltage arrester is visible to the far right.

Further on the subject of controls, the installation of the solid state circuit breakers into an existing system has provided the opportunity to upgrade the instrumentation of this system. System control, which formally consisted of mechanically driven contactors and transformer taps, has now been supplemented by a computer based control and measurement system. The computer is an Apple Macintosh IIx running the National Instruments LABVIEW instrumentation software package. The computer is interfaced to the existing control system via four plug in boards, which support various digital I/O, D to A and A to D function via new interface chassis, which have been installed in the existing control rack cabinets of the power supply. The computer also interface, via IEEE 488 bus, to two CAMAC systems, which, at the present are hosting seventy-six channels of data acquisition.

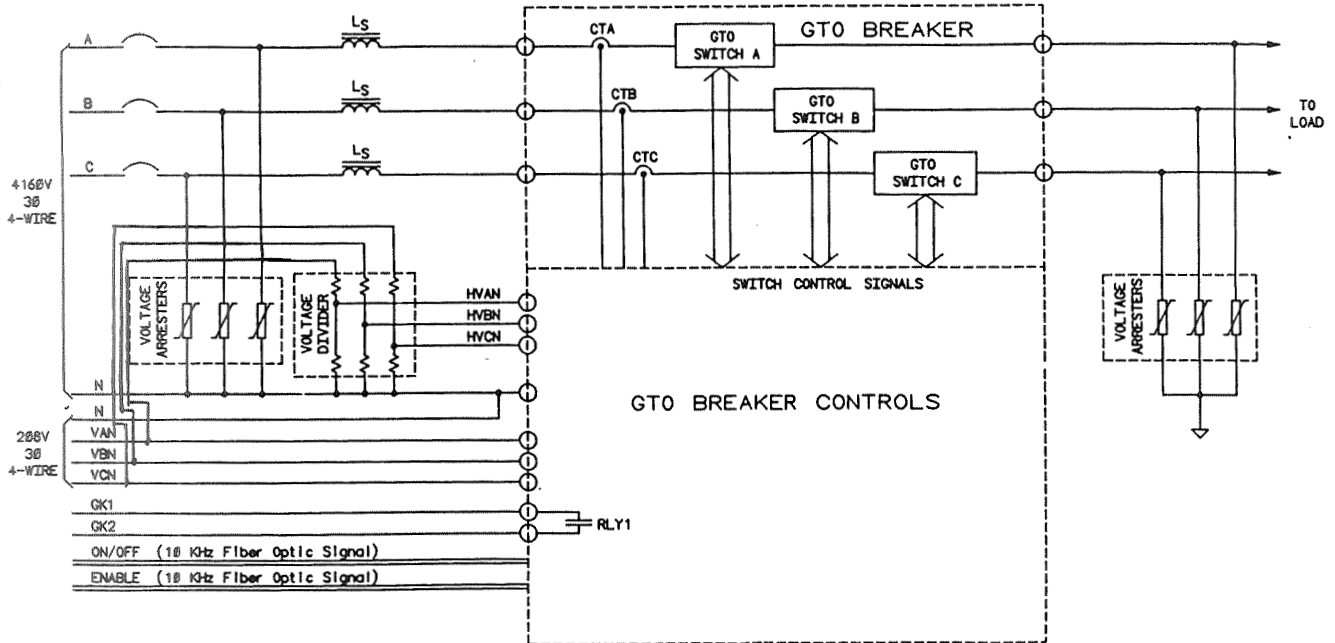

Figure 4: Schematic of installation of the solid state circuit breaker. Note the saturable core reactors and mechanical disconnects in the line side, to the left, and the voltage arrester in both line and load sides. Note also the voltage dividers, which measure phasing off the 208 V control power. Original plan had the voltage dividers measuring off the 4160 V mains, but it is possible to have no voltage on the mains, due to the aforementioned mechanical disconnects, and still need to sense phase. A thirty degree phase shift between the 4160 V and 208 V circuits is factored into the control algorithm.

The desire to add, subtract and modify this data acquisition capability lead to the selection of the CAMAC standard for this purpose. The instrument suite is completed by a custom peak/fault detector, which records peak currents and fault occurrences and will trip the system if fault number or rate per specified unit time exceeds operator set limits. The system was designed and built by Maxwell Laboratories, San Diego, CA.

STATUS OF PROGRAM

The solid state circuit breakers were completed and installed in 1991. The high voltage wiring installation was done by the Army's 535th Combat Engineering Detachment, which has a contingent based at Fort Monmouth. This military unit specializes in the installation of electric generation and distribution on the battlefield, utilizing 1 MW all fuel turbine driven 4160 V generators mounted on trailers, palletized distribution transformers and all the associated cabling. An deployed Army division requires 5 MW of electric power generation.

The new controls for the system were installed in 1992. A control problem delayed final testing of the system. However, preliminary results are available and are illustrated in Figure 5. Note the bottom trace; it is the control signal. The abrupt end of this signal is the trip command. The top trace, the current, drops to zero within 300 microseconds, exclude some small ringing out which is attributable to load conditions.

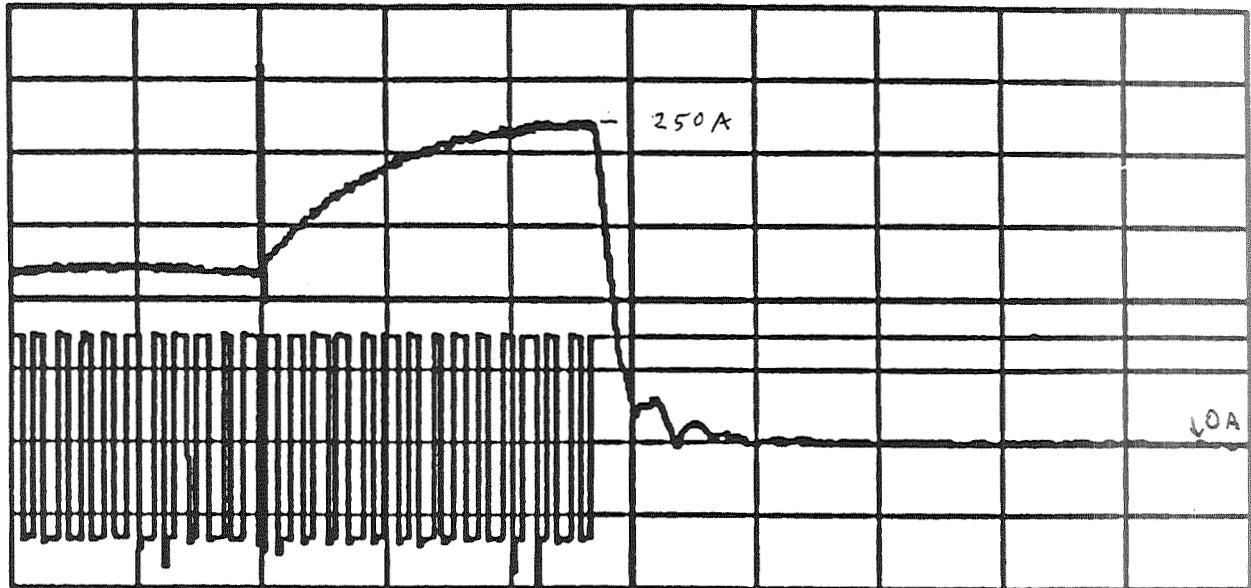

Figure 5. A test trip of one solid state circuit breaker. The top trace is the circuit breaker current and one vertical division is equal to 50 Amperes. One horizontal division is equal to 500 microseconds. The bottom trace is the 10 kHz control signal, one vertical division is equal to 5 volts. At 1 millisecond into the event, an over current is induced into the system by shorting out a portion of the load resistance. At approximately 2 milliseconds into the event, the current exceeds the trip value. The control signal ceases at 2.8 milliseconds into the event and the solid state circuit breaker trips in approximately 300 microseconds. The circuitry producing the control signal cessation is one of the slower modes, in this case; faster responses for this signal drop are possible.

FUTURE APPLICATIONS

The present application was for a utility type device, in which size and weight is of little consequence. Future units should be made much smaller. There are military applications for units of this nature. These would be in connection with the previously mentioned 1 MW trailer mounted generators. All three services use these systems. The Army, as previously mentioned, uses these for field power generation. The Navy uses them to power ships in port and the Air Force uses them to provide power to aircraft and associated equipment on the flight line. Since these operations must be portable on a worldwide basis, it is imperative that such units be lightweight, compact and rugged.

The latter requirement makes the solid state circuit breaker ideally suitable, in that it will replace the present day system which is based on mechanical contactors, often housed in fragile glass vacuum envelopes.

Civilian applications are also foreseeable for this technology, including protection of utility lines, the realization of a nonmechanical reclosure, with remote, adjustable settings, the protection of valuable industrial equipment, the improvement of power quality and balancing, improved synchronization of capacitor banks for power correction, diverters for industrial loads, power brokerage from one utility to another and intelligent power control in industrial systems. Again, these may be done at the megawatt level.

The solid state circuit breaker will achieve reduction in size and weight by several technical innovations. The first is the replacement of the current air cooling with one or two phase liquid cooling systems. Preliminary discussions with the builder of the current solid state circuit breaker indicates that size reduction, with incumbent weight reduction, to one or two cubic feet of volume for a unit rated similarly to the present units is quite conceivable. The second innovation will be a replacement of the GTOs with more advanced semiconductors. Recently developed devices have less demanding driver and snubber requirements, which will result in smaller auxiliary circuits. Further improvement may be obtained due to the more efficient nature of these devices, resulting in fewer thermal management requirements due to enhanced performance in conduction and switching.

CONCLUSION

The solid state circuit breaker is about to begin a new era in fault protection for power systems. Future more advanced systems will open up new applications both terrestrial and space based. Such devices will insure less damage due to the shortening of the time during which a fault condition exists and higher reliability due to the elimination of moving parts.

ACKNOWLEDGMENTS

The author would like to acknowledge the efforts of the two principals on this project, Dr. F. Owen Johnson of the Westinghouse Science and Technology Center and Dr. George Schofield of Maxwell Laboratories. A note of special thanks goes to Chief Warrant Officer Borst, Staff Sergeant K. Payne and Sergeants K. Chaney, C. Claxton, A. Potter, D. Brown, R. Simpson and J. Moss of the 535th Combat Engineering Detachment.