

ESA'S PLANNING AND COORDINATION OF THE  
OLYMPUS PROPAGATION EXPERIMENT

B. Arbesser-Rastburg

ESA-ESTEC, Wave Interaction & Propagation Section  
Keplerlaan 1, NL-2200 AG Noordwijk, The Netherlands

**Abstract** - An overview of the organization of the OLYMPUS propagation experimenters' group (OPEX) is given. The paper describes preparations, participation, and experiments. Some examples for first statistical results are also reported.

### 1. Introduction

OLYMPUS, a 3-axis stabilized communications satellite was launched in 1989 for providing experimental telecommunications payloads and a propagation beacon payload at 12, 20 and 30 GHz to the European Space Agency. From previous experience (OTS), the Agency undertook to carry out extensive preparations with an eye on obtaining the statistical results needed within the limited available lifetime of the spacecraft. The OLYMPUS propagation experiment was conceived as part of ESA's space telecommunications applications programme (ESA/IPC/(79)83) with the emphasis on exploring the possibilities and limitations of Ka-band satellite communications. The objectives of the OLYMPUS Propagation campaign were:

- o characterization of the slant-path propagation conditions at 20/30 GHz in the various climatic regions of Europe.
- o Improvement of the understanding of the link between atmospheric observable (rainrate, cloud thickness etc) to propagation impairments such as attenuation, depolarization, scintillation, etc.
- o Arrive at improved propagation prediction methods.

### 2. The Definition Phase

ESA, after having coordinated the European participation in the ATS-6 campaign (1976-1977) and organized the OTS propagation campaign which resulted in the COST 205 project (COST stands for CoOperation Scientifique et Technique) was well aware of the requirements for setting up a successful international cooperation for propagation measurements. Thus, the OPEX group was established almost 10 years before the launch of the OLYMPUS spacecraft with the aim of arriving at joint specifications for the crucial parts of the experiments:

- o the experimental hardware
- o the data acquisition and preprocessing
- o the data analysis

Working groups were set up for each of these topics and the results were summarized in handbooks ([1], [2], [3], [4]).

From the very early stages, a core of about 40 participants attended the meetings regularly and provided invaluable contributions. Also present in this group were manufacturers who were interested in building beacon receivers and radiometers to the requirement of the experimenters.

## 2.1 Payload Specifications

OLYMPUS has 4 payloads:

- TV broadcast payload (18/12 GHz, 2 Channels, steerable beams)
- Specialised Services Payload (14/12 GHz, 5-beam steerable ant).
- 30/20 GHz Payload (28/19 GHz, 2 steerable spotbeams)
- Propagation payload.

The propagation payload was designed to offer a high degree of stability throughout the lifetime of the spacecraft and at same time reliability which can only be achieved by a complete redundancy concept. A block diagram of the OLYMPUS beacon payload is shown in Figure 1. To allow for differential phase measurements, the 3 beacons were designed a coherent signals, all derived from the same 48.456845 MHz oscillator. The oscillator frequency is first multiplied by 6, producing a sine-wave of 290.74107 MHz. For generation of the B0-beacon the 290 MHz is multiplied by 43 and then amplified by a solid state amplifier operating at a frequency of 12.501866 GHz. The B0 antenna is a horn which provides global coverage as shown in Figure 2. The transmitted signal is linearly polarized in the Y-plane (North-south at the sub-satellite point).

The 290 MHz signal is also fed to a x34 multiplier which generates a frequency of 9.885 GHz for use by the B1 and B2 transmitters. This frequency in turn is doubled to produce the B1 beacon frequency of 19.770393 GHz. A TWT amplifier is responsible for producing the required power. The transmitted signal is alternating between two orthogonal (X and Y) polarization planes with a switching cycle of 933 Hz (535.9 microseconds in each state). For test purposes, the transmit polarization can also be fixed to either the Y or X plane by means of telecommand.

The 3-dB contour covers all of Europe and a large part of Northern Africa. (see Figure 3).

For the B2-beacon the 290 MHz signal is tripled, producing 29.655 GHz which again is amplified by a TWTA. The polarization is linear Y (same as B0) and the coverage is identical to that of B1. The performance of the payload was verified during the in-orbit test carried out in Redu and several other European sites except for the failure of the B1/B2 redundant channels, nominal performance was found [5].

## 2.2 Experiment Specifications

Not all experimenters had the same level of support in terms of available finances and manpower and yet, within these constraints a set of minimum requirements and recommendations was drawn up [1]. In addition to the beacon receiver(s) a radiometer (ideally an atmospheric water radiometer with 2 or more frequencies) and a raingauge were considered basic experimental inventory. Other meteorological instruments, such as sensors for temperature, humidity and pressure were also highly recommended. A copolar dynamic range of 20 dB at 12 GHz was advocated, with the higher frequency beacon receivers slaved to the same local oscillator to achieve a measurement that is not impaired by "loss-of-lock conditions" during all but the most intensive rainstorms. For the crosspolar measurements a minimum dynamic range of 10 dB from the clear sky level was advised. The data recording rate was suggested to be 1 second for the beacon signals (at least during "events") and 1 minute for the meteorological channels. Several experimenters have data acquisition systems allowing for 10 Hz recording for scintillation measurements.

It was also considered important that stations with a 3 dB beamwidth of less than 0.7 degrees should employ antenna tracking. This was of course assuming that spacecraft inclination was kept within a 0.1 degree window.

With the decision made in April 1992 to stop North/South station-keeping to preserve manoeuvre fuel this recommendation this recommendation is of course no longer sufficient, since after one year of operation the inclination will grow to 0.8 degrees.

### **2.3 Data Processing Software specifications**

In designing the data processing and analysis software, the objective was to have standardized procedures leading to fully compatible results which is an essential requirement for testing prediction methods. The first set of "User Requirements" was prepared by the early Working Parties [2], [3]. These requirements outlined the basics of data collection to the presentation of statistical results. ESA then invited a consortium of software houses to perform a feasibility study which led to a new set of "User Requirement Documents" [6], [7] and a set of "Software Requirement Documents" [8], [9]. After a thorough review of the proposed implementation, a contract was negotiated with a software house, supported by a propagation research team, to implement the data processing and analysis software according to ESA's Software Engineering Standards [10]. The preprocessing module is designed to read the raw data, convert the values to physical units, remove the clear-sky variations and finally store the resulting data sets as standard event files on optical disk. The analysis software reads the standard event file, identifies data gaps in individual channels and generates the tabular and graphical output of single and joint statistics.

### **3. The Experiments**

The European Space Agency commissioned the development of new equipment such as a prototype digital beacon receiver and atmospheric water radiometers but the individual experiments were required to purchase their own equipment, find suitable measurement sites and carry out the operation. The major obstacle in achieving a 50 site experiment was slow delivery of the receivers - now the number of sites contributing long term data is slightly below 40. A complete list of the station locations is given in Table 1. For the next OPEX meeting, a summary document will be prepared by ESA listing all relevant parameters of the individual stations, including the period(s) of measurement.

In addition to the stations shown in Table 1, there were also several places where in intermittent operations the beacons were used to check out receiving stations and even some large radio telescopes made use of the beacon signals as external test sources.

ESA provided and continues to provide all operators with the orbital elements and pointing predictions as shown in part in Table 2.

### **4. Topics pursued in the OPEX Working Groups**

With the launch of the spacecraft, the original 3 working groups had completed their tasks (to define and prepare the experimental hard- & software) and it seemed prudent to form new working groups aiming at the analysis of the collected data.

Today the following Working Groups exist:

#### **Software Working Group**

This is largely a users' group of the standard data preprocessing and analysis software DAPPER. This software, which was developed under ESA Contract to the specifications of the users has been distributed to all signatories of the OPEX agreement. This agreement serves both, as a software sub-license as well as an legal guideline and protection for exchange of data between experimenters.

The large flexibility of DAPPER (in the latest version, 2.3, it also caters for combined OLYMPUS-ITALSAT experiments) together with the fact that many of the users are not yet familiar with UNIX caused many of the users to have difficulties with the proper setup procedures. In addition, like with all complex new software packages, the first releases had some bugs that added to the problems. The Software Working Group is exchanging information on the best way of using the programme, on the best way of achieving the desired results and on how to adapt the system to special situations such as site diversity configurations. At the most recent OPEX Meeting, several users expressed interest in developing utilities and set-up recommendations for special applications. ESA interfaces between the users and the software

manufacturer for users inquiries and maintains a database with all the information relevant to the use of DAPPER, including work-arounds, recommended computer configurations etc. Users can down-load this information via e-mail and submit their own observations and comments via e-mail.

Siemens is offering a course for the users.

### **Attenuation Working Group**

This working group deals with the bulk of the propagation analysis and its aim is to relate as closely as possible results of the experiments to the needs of satellite systems planners.

Besides the annual and worst months statistics of rain attenuation, fade duration and fade slope as well as the concept of risk and return period are being addressed. Also scintillations and site diversity performance are an important part of the work. The group decided on using the CCIR Recommendation 311 (which had been drafted by ESA) as guideline for the presentation of data. The group aims at producing a collective book with relevant results, with a first draft to be circulated at OPEX 18.

### **20 GHz / XPD Working Group**

The Working Group's scientific goal is to derive the anisotropy of hydrometeors from the orthogonally polarized 20 GHz beacon signal. Several BI receivers are receiving co-and crosspolar levels at both polarization, allowing to characterize the complex transmission matrix of the atmosphere. The system oriented goal of the group is to improve the prediction model for cross-polarization due to rain and ice. In particular, ice was found to give a substantially larger contribution at 20/30 GHz than the current CCIR method allows for.

The Group plans to summarize the results in a handbook.

### **Radiometry & Meteorology Working Group**

Radiometric measurements have turned out to be a "must" for slant path propagation measurements at Ka-band and above. As a result, virtually all experimenters have one or more radiometers deployed alongside the beacon receivers. The group is working on validation of retrieval algorithms for liquid water and water vapour. The DAPPER implementation uses Liebe's model [11] for retrieval and frequency scaling.

For meteorological measurements the Working Group collects information on the practical experience with a variety of instruments, ranging from different types of raingauges to distrometers and ceilometers. The results of the work will be published in a Handbook of which an outline has been agreed upon at the most recent OPEX meeting.

### **Radar Working Group**

Several experimenters have access to multi-parameter (dual polarization, FM-CW Doppler, etc) radar station that allow to make fine scale measurements of the hydrometeors. The Working group is concerned with comparing calculations of electromagnetic scattering from rain-drops, from the melting layer and from ice particles. The results will be presented in a handbook, along with information on the radar measurements associated with beacon experiments. Good examples for the progress made within this group can be found in the Proceedings of last year's "Multi-Parameter Radar" Workshop [12].

## **5. First statistical results and their significance**

Due to the interruption in the operation of the spacecraft and the delayed completion of the data processing software, only a few experiments have yielded annual cumulative statistics so far. Some examples, arbitrarily selected, are presented below. Contributions cited as "private communication"

have been supplied for planning advise to EUTELSAT; the complete dossier will be published in the Proceedings of OPEX 17.

#### **BT Laboratories Martlesham, England**

The site is located in CCIR climate zone E ( $R_{0.01}=22$  mm/h), the elevation angle to OLYMPUS is 27.5 degrees. The data collection took place from 1 November 1989 to 29 May 1991. The plot in Figure 4 shows the Worst Month attenuation at 29.7 GHz for the calendar year 1990 [13] and for comparison, the prediction from CCIR Report 564-4 [14].

#### **Deutsche Bundespost Telekom Research, FTZ Darmstadt.**

The measurement site is located at the premises of FTZ in Darmstadt. The measured rainrate at 0.01 percent of the year is 32 mm/h. Annual cumulative distribution of fade [15] is presented in Figure 5.

#### **Telecom Denmark**

Telecom Denmark has carried out beacon measurements in Albertslund at an elevation angle of 20.7 degrees. Annual cumulative distributions of fade [16] are shown in figure 6. An example for the XPD statistics [17] is presented in Figure 7.

### **6. Conclusions**

The European Space Agency planned the spacecraft, supported receiver development and provided support for the software development. And yet, without the dedication of the OPEX community the campaign would have hardly become as successful as it now appears. This dedication comes from the deep desire to excel in measurement and research, to show results at the regular gatherings of the group and to harvest the fruits of the long and laborious preparations.

After some teething problems the DAPPER software has begun to be used in "production" scale data analysis - the lesson learned is that one cannot start soon enough to prepare.

There is only one year left to make propagation experiments with OLYMPUS. But in spite of the interruption, it is expected that the carefully collected and processed data will continue to provide new exciting results in the years to come. The OPEX community which has only recently been joined by experimenters from eastern European countries will therefore continue to collaborate for the foreseeable future. The collection of results and presentation thereof in "Handbooks" will be particularly interesting in the light of comparison with new results expected to come from the ACTS campaign and the ITALSAT propagation experiments.

### **7. References**

1. OPEX Handbook for Beacon Receiver Design, Editor S.K. Barton, January 1985
2. OPEX Handbook for Data Preprocessing, Editor: A. Mawira, September 1986
3. OPEX Requirements for Data Analysis, Editor: A. Paraboni, June 1986
4. OLYMPUS Users' Guide, Propagation Package, UG-6-1, Editor: Owen Turney, Issue 3, March 1989

5. B. Arbesser-Rastburg, OPEX Measurements and Studies, Proc. NAPEX XIV, pp 29-35, JPL Publ. 90-27, May 1990
6. J. Koller, G. Diermaier and F. Murr, "User Requirement Document Part 1, Data Processing Software, ESA Contract 7609, Nov 1988
7. T. Brunt (CSRL), "User Requirements Document, Part 2, Data Analysis Software" ESA Contract 7609, Nov 1988
8. J. Koller, G. Diermaier & F. Murr "Software Requirements Document, Part 1, Data Processing Software", ESA Contr. 7609, Nov 1988
9. T. Brunt "Software Requirements Document, Part 2, Data Analysis Software, ESA Contr. 7609, Nov 1988
10. ESA BSSC: "ESA Software Engineering Standards", ESA PSS-05-0, Issue 2, Feb 1991.
11. H.J. Liebe, "MPM - An atmospheric millimetre wave propagation model", Int. J. Infrared Millimetre Waves, Vol 10, No 6, pp 631-650, 1989
12. ESA, JR, ASA, Proceedings of International Workshop on Multi-Parameter Radar applied to Microwave Propagation, Graz, ESA WPP-20, Sept 1991.
13. BT, Private communication, November 1991
14. CCIR, Study Group V, " Propagation Data and Prediction Data required for Earth-Space Path Telecommunications Systems", Recommendations and Reports, Report 564-4, Duesseldorf 1990.
15. DBP Telekom, private communication, November 1991
16. TELECOM Denmark, private communication, November 1991
17. J.R. Larsen & S.A.J. Upton, "Report of 20/0 GHz Slant Path Measurements 1982-1990", NRSK-kTB Report Dec. 1991

LOCATION	Country	LAT [deg]N	LON [deg]E	ALT [m]	ELEV. [deg]
Graz	AT	47.07	15.49	489	25.72
Lessive	BE	50.22	5.25	162	27.81
Louvain	BE	50.67	4.62	160	27.61
Ottawa, Ont	CA	45.00	-76.00	100	14.08
Prague	CS	50.04	14.49	280	24.10
Darmstadt	DE	49.87	8.63	180	26.85
Oberpfaffenhofen	DE	48.08	11.28	580	26.76
Albertslund	DK	55.68	12.36	30	20.61
La Folie Bessin	FR	48.65	2.20	160	30.33
Gometz la ville	FR	48.67	2.12	170	30.32
Brindisi	IT	40.66	18.00	20	29.72
Firenze	IT	43.76	11.26	50	31.10
Foggia	IT	41.46	15.49	70	30.58
Fucino	IT	41.98	13.60	600	30.59
Lario	IT	46.15	9.40	200	29.76
Matera	IT	40.66	16.58	200	30.36
Milano	IT	45.46	9.21	120	30.55
Napoli	IT	40.86	14.30	30	31.79
Roma Eur	IT	41.83	12.47	50	32.04
Spino d' Adda	IT	45.50	9.50	84	30.43
Torino	IT	45.10	7.52	230	31.49
Torino CSELT	IT	45.07	7.67	238	31.44
Trento	IT	46.08	11.12	190	29.04
Verona	IT	45.40	11.00	60	29.84
Delft	NL	52.09	4.39	10	26.54
Eindhoven	NL	51.45	5.49	15	26.78
Leidschendam	NL	51.00	4.37	8	27.58
Kjeller	NO	59.98	11.03	20	17.34
Aveiro	PT	40.65	8.90	20	34.97
Helsinki	SF	60.22	24.40	60	12.59
Chilton	UK	51.57	-1.28	100	28.56
Coventry	UK	52.42	-1.52	100	27.76
Martlesham	UK	52.06	1.29	25	27.48
Guildford	UK	51.24	-0.58	67	28.10
Blacksburg	US	37.90	-75.70	150	17.17
Blacksburg Rem	US	37.85	-75.69	140	17.21

**Table 1:** Locations with active or completed OLYMPUS beacon experiments.

OLYMPUS EXPERIMENTERS ANTENNA POINTING FIT

ORBITAL ELEMENTS IN PEPSOC SYSTEM

SEMI MAJOR AXIS (KM) = 42166.477010  
 ECCENTRICITY = .000190  
 INCLINATION (DEG) = .140838  
 ASCENDING NODE (DEG) = 95.850955  
 ARG. OF PERIGEE (DEG) = 294.172104  
 TRUE ANOMALY (DEG) = 8.333548

STATE VECTOR IN PEPSOC SYSTEM

X - COMPONENT (KM) = 33059.079857  
 Y - COMPONENT (KM) = 26161.636031  
 Z - COMPONENT (KM) = -87.394444  
 X - COMPONENT (KM/SEC) = -1.908229  
 Y - COMPONENT (KM/SEC) = 2.411478  
 Z - COMPONENT (KM/SEC) = .004062

SUBSATELLITE POINT

LONGITUDE (EAST, DEG) = -19.047  
 LATITUDE (NORTH, DEG) = -.119

EPOCH (UT) = 1992/ 5/19 AT 12: 0: 0

ANTENNA POINTING DATA

-----  
 START DATE (=REF. TIME) 1992/ 5/21 AT 10: 0:00 UT  
 END DATE 1992/ 5/27 AT 12: 0:00 UT

STATION		CONSTANT	LINEAR	SINUS	COSINUS
GRAZ	AZ	223.2739	-.0078	-.0062	-.0847
	EL	26.3547	.0035	.0183	-.1481
LESSIVE	AZ	210.4693	-.0085	-.0095	-.0591
	EL	28.0243	.0024	.0173	-.1586
LOUVAIN	AZ	209.5700	-.0085	-.0097	-.0568
	EL	27.8219	.0023	.0172	-.1592
RIO DE J	AZ	48.6750	.0099	.0003	.1944
	EL	51.9441	-.0056	-.0205	.1273
OTTAWA	AZ	114.6879	-.0060	-.0194	.1090
	EL	14.2790	-.0049	.0017	-.1223
DARMSTA.	AZ	214.4824	-.0083	-.0085	-.0661
	EL	27.0875	.0027	.0176	-.1559

Table 2: Example for Orbital elements and pointing predictions distributed by ESA on a weekly basis.



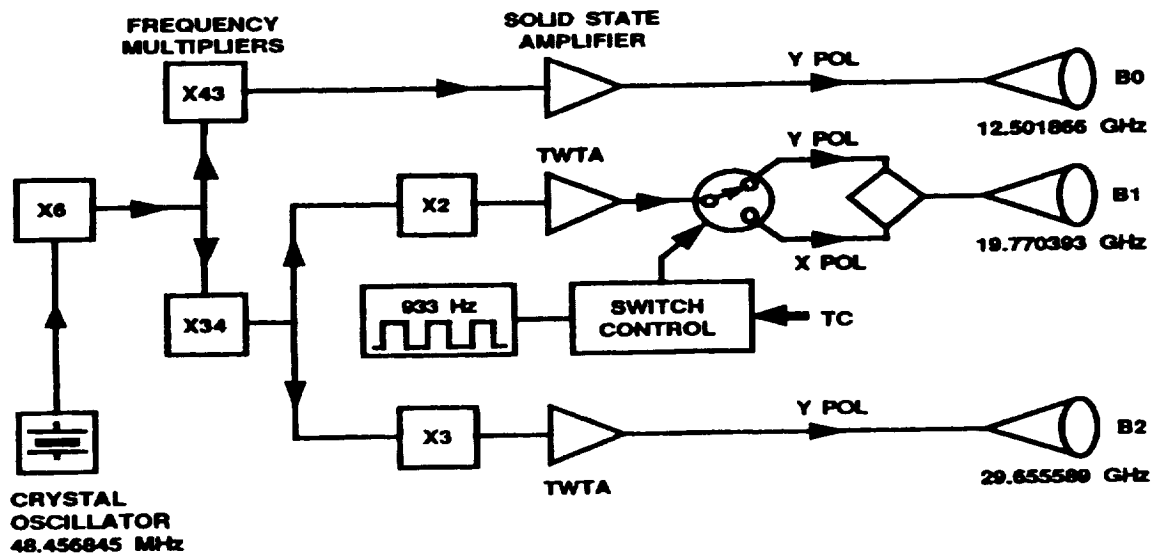

Figure 1 Block Diagram of the OLYMPUS propagation beacon payload (ESA CCE/54989/RAG/CK)

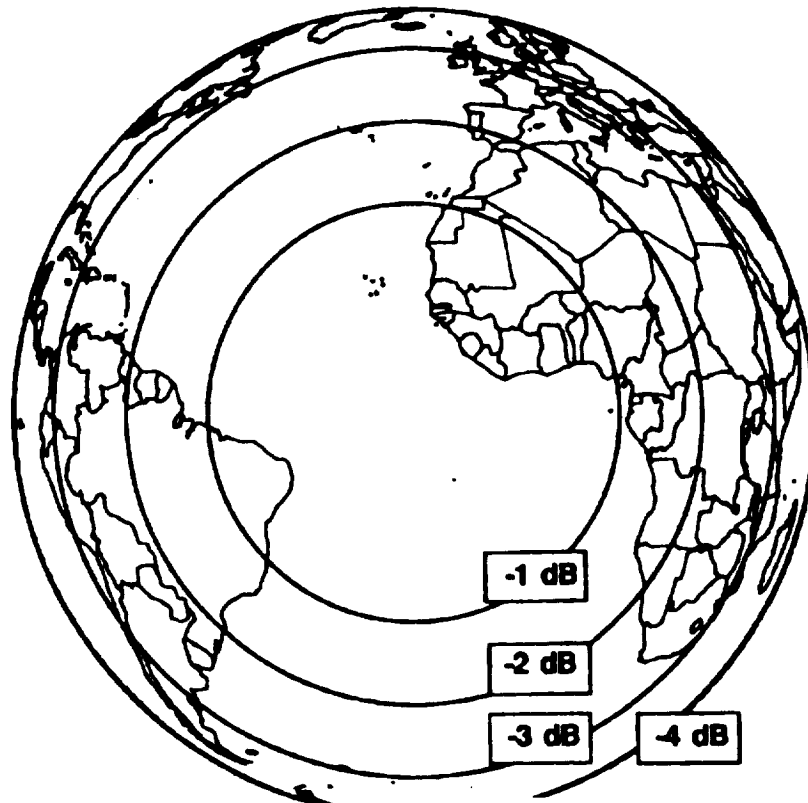

Figure 2 Coverage of the OLYMPUS B0 beacon

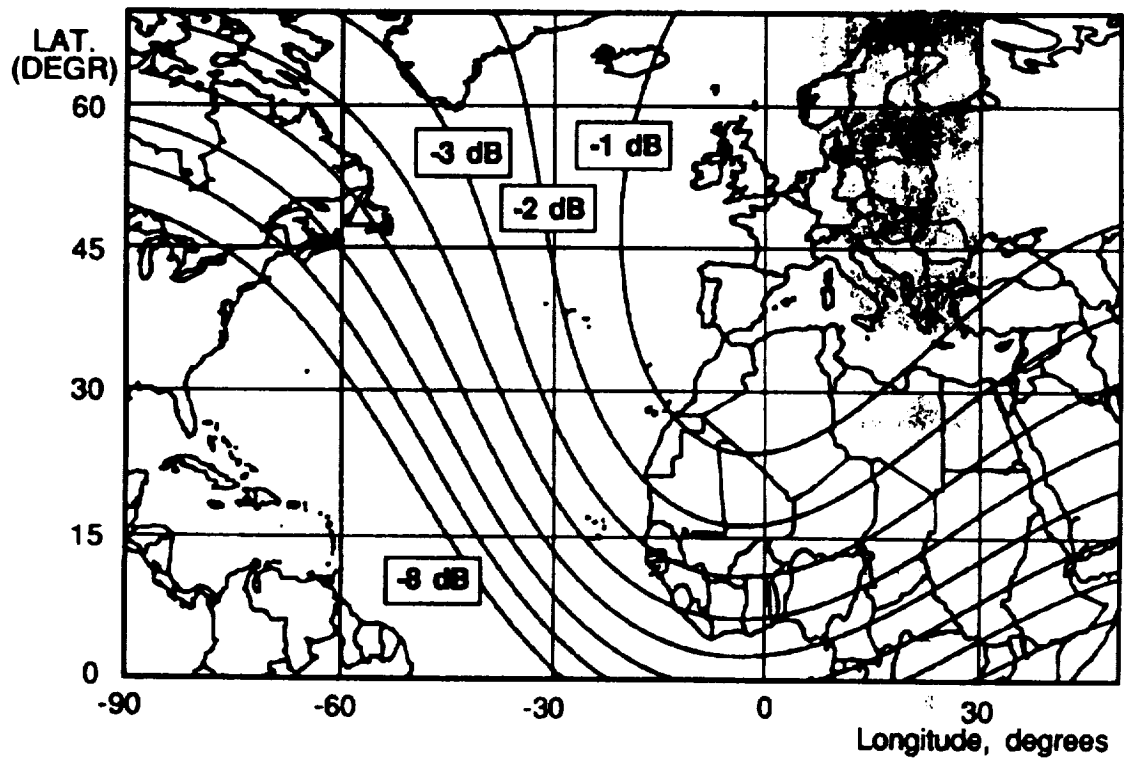

Figure 3 Coverage of the OLYMPUS B1 and B2 beacons

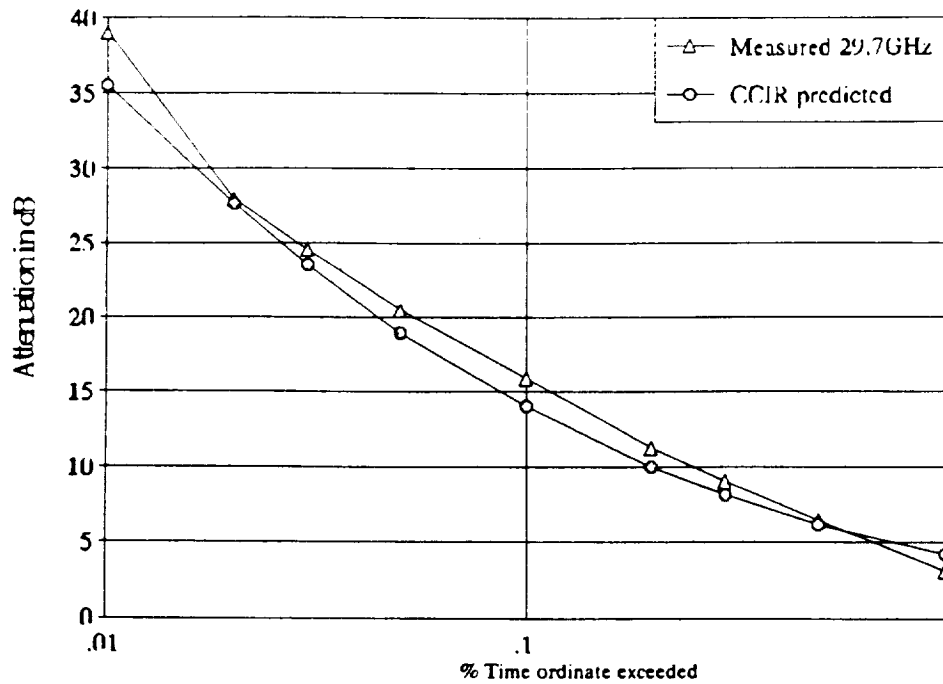

Figure 4: Worst Month (period 1/90 - 12/90) attenuation measured (triangles) and predicted (circles) for 29.7 GHz at Martlesham, U.K. (OPEX Advise to Eutelsat Fig A2.1-3)

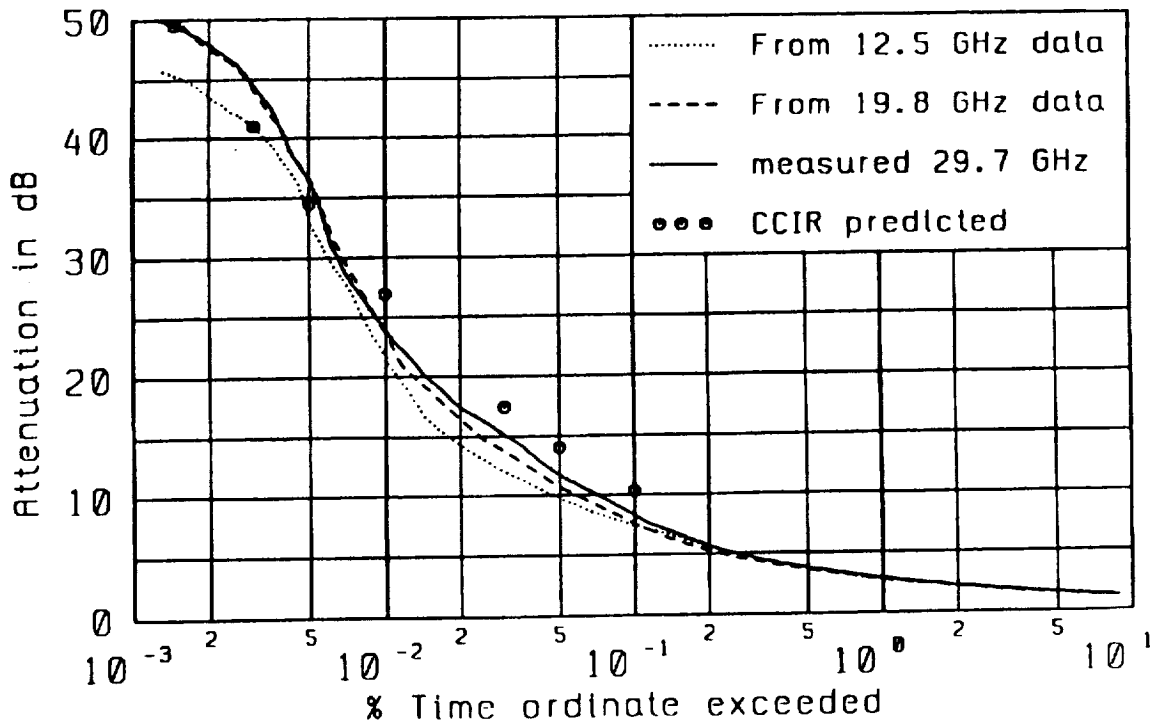

Figure 5 Annual CD (period 5/90 - 4/91) of attenuation for 29.7 GHz at Darmstadt, Germany.

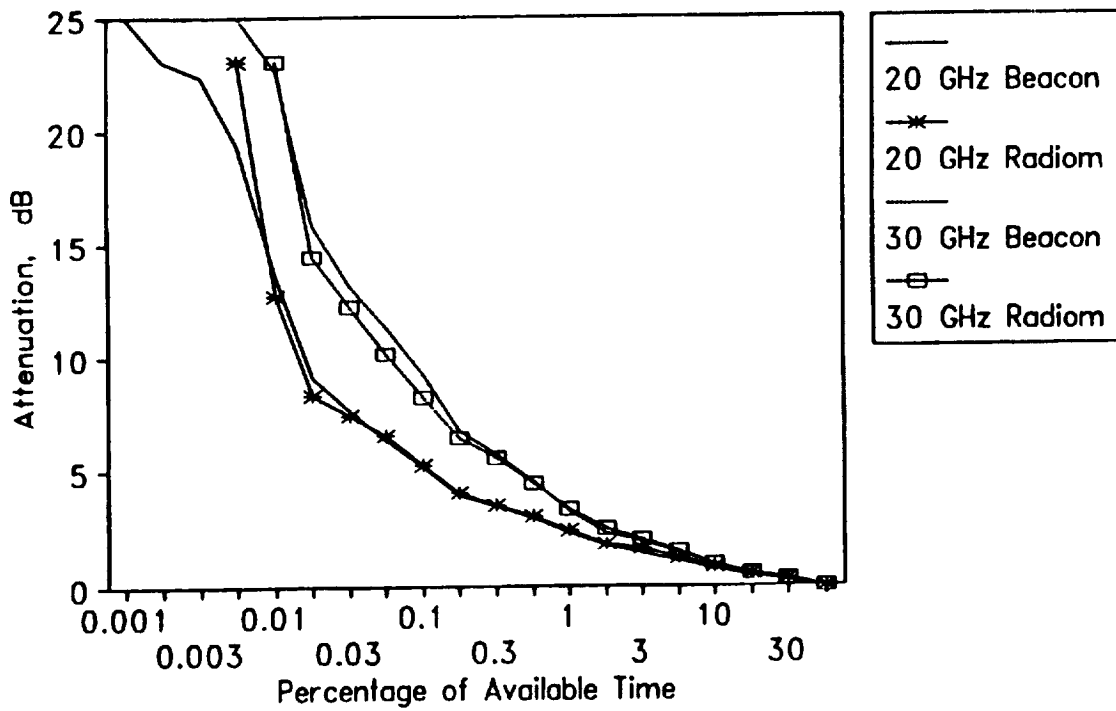

Figure 6 Annual CD (period 10/89 - 09/90) of attenuation for 19.7 and 29.7 GHz at Albertslund, Denmark.

# XPD Annual C.D. Albertslund, Olympus Year

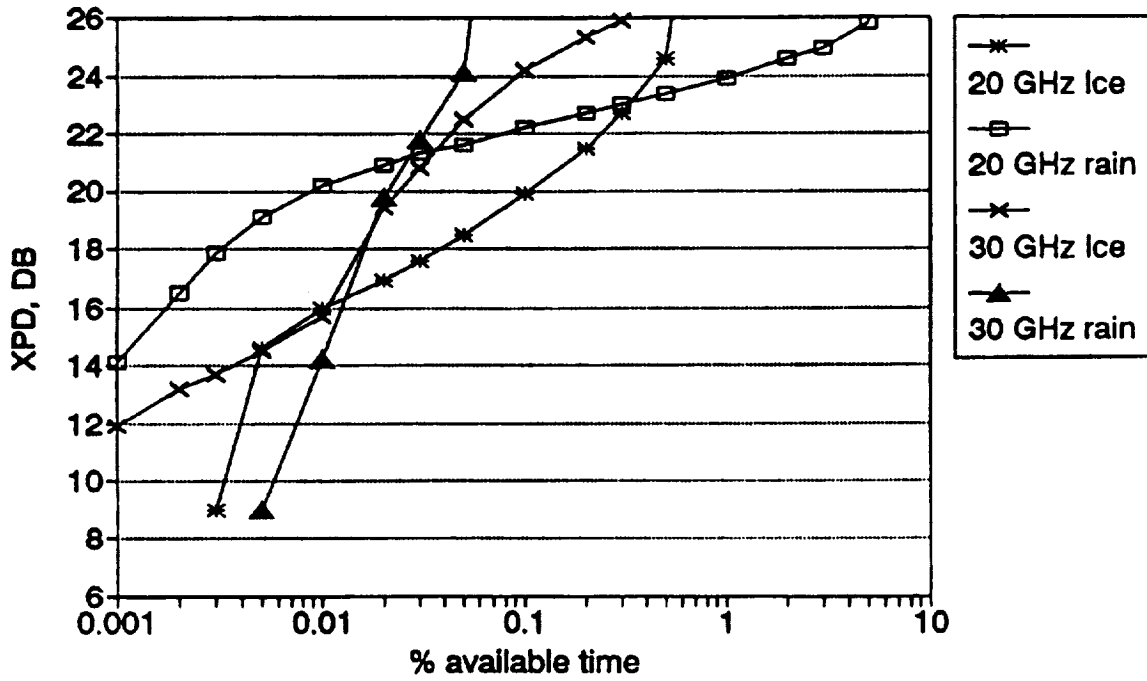

Figure 7 Annual CD (period 10/89 - 09/90) of XPD at 19.7 and 29.7 GHz at Albertslund, Denmark