

**The ECLSS Advanced Automation Project
Evolution and Technology Assessment**

Presented to:
Technology for Space Station Evolution Workshop
January 17, 1990

Research by:
The Environmental Control and Life Support System
Advanced Automation Project, Transition Definition

Principal Investigator:
Brandon S. Dewberry
NASA/MSFC/EB42
MSFC, AL 35812
(205) 544-4247
NASAMAIL: BDEWBERRY

Support:
James R. Carnes
Boeing AI Center
P.O. Box 240002, M/S JA-74
Huntsville, AL 35824-6402
(205) 461-2348
email: ray@huntsai.boeing.com

Johnson Research Center
Advanced ECLSS Analysis Team
Brenda D. Lukefahr
Daniel M. Rochowiak
Brian L. Benson
The University of Alabama in Huntsville
Huntsville, AL 35899
(205) 895-6257
John S. Rogers
James W. McKee

PRECEDING PAGE BLANK NOT FILMED

543

542
INTERNATIONAL PAVIA

519-574
163611
22
N93-27723

The ECLSS AAP Evolution & Technology Assessment

Introduction Description

The Environmental Control and Life Support System (ECLSS) aboard Space Station Freedom will sustain a safe, shirt sleeve environment for its crew and payloads. Development has been divided into six functionally interconnected subsystems: Temperature and Humidity Control (THC), Waste Management (WM), Fire Detection and Suppression (FDS), Atmosphere Control and Supply (ACS), Water Recovery Management (WRM), and Air Revitalization (AR). The last two subsystems, WRM and AR, close air and water environmental loops to an extent never before attempted in space, and will require new technologies which are being extensively tested and analyzed.

The ECLSS Advanced Automation Project

The objective of the ECLSS Advanced Automation Project (ECLSS AAP) is to recommend and develop advanced software for the initial and evolutionary Space Station Freedom ECLS System that will minimize the crew and ground manpower needed for operations. This will be accomplished by first determining which processes may benefit from advanced automation technologies, second, determining the strategies necessary for development and integration of advanced automation systems into the ECLSS project, third, describing the evolutionary path from the baseline ECLSS automation to the more advanced ECLSS automation processes, and fourth, developing advanced automation systems for the ECLSS domain while demonstrating their utility.

PRECEDING PAGE BLANK NOT FILMED

545

544
REPRODUCTION PERMITTED

The ECLSS AAP Evolution & Technology Assessment

The first step, determination of ECLSS processes for application of advanced automation technologies, is complete. These processes are outlined in **NASA-MSFC-8-36955-25 ECLSS Advanced Automation Preliminary Requirements - Final Report** and in **The ECLSS Advanced Automation Project Phase I Results presentation to Space Station Transition Definition Code ST**, the sponsor of this work.

The second and third steps are described in the ECLSS AAP Project Plan, Management Plan, and Development and Delivery Plan produced by the Artificial Intelligence Center of Boeing Computer Services. Knowledge acquisition and engineering are currently underway in response to the fourth objective.

The ECLSS AAP Evolution & Technology Assessment

Introduction

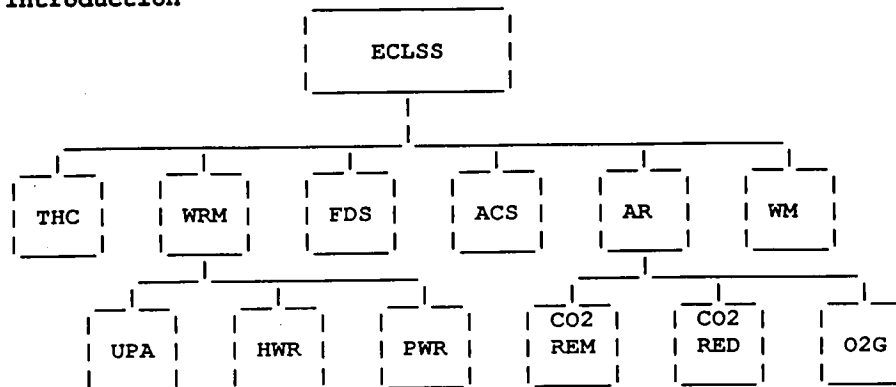

* The ECLSS Advanced Automation Project (ECLSS AAP)

* Objective: Automation of the Evolutionary ECLSS

* Approach:

- 1) determine applicable processes
- 2) determine development and implementation strategies
- 3) describe ECLSS evolution from baseline to advanced
- 4) develop systems and demonstrate their utility.

* Status:

- 1 - completed in phase I - ECLSS Analysis
Documented:
MSFC-8-36955-25 ECLSS Advanced Automation
Preliminary Requirements - Final Report
The ECLSS Advanced Automation Project Phase I
Results presentation to Space Station Transition
Definition Code ST, the sponsor of this work.
- 2&3- completed but in flux
Documentated:
The ECLSS AAP Project Plan, Management Plan, and
Development and Delivery Plan produced by the
Artificial Intelligence Center of Boeing Computer
Services.
- 4 - In process
Knowledge acquisition and engineering development
currently underway.

Introduction Description (continued)

The ECLSS AAP Analysis Overview

Preliminary study indicates the baselined ECLSS is an advanced, flexible, and autonomous system in many areas. Other areas were found in which increased automation should be built in or scarred in its hardware and software systems for evolution. The analysis was performed by both chemical and software experts in order to produce a total ECLSS automation and technology assessment, and applications of advanced software to ECLSS subsystems are emphasized.

Analysis Results

The three research and development areas most apparent in the analysis are autonomous fault detection and isolation of ECLSS processes and subassemblies, advanced chemical and microbial fluid inspection, verifiable closed loop modelling of chemical and microbial recombination in the regenerative processes.

The names applied to these development areas are:

- 1) Automatic Fault Diagnosis of ECLSS Subsystems,
- 2) In-line, Realtime Chemical and Microbial Fluid Analysis,
and
- 3) Object-oriented, Distributed Chemical and Microbial
Modelling of Regenerative Environmental Control Systems

These technology topics are discussed individually below, giving a description of the technology including the rationale behind its endeavor, and possible approaches to development.

The ECLSS AAP Evolution & Technology Assessment

Introduction (continued)

* ECLSS AAP Phase I Analysis Overview

- * The ECLSS is an advanced, flexible, and autonomous system in many areas.
- * Deficiencies in
 FDIR,
 Fluid Analysis Instrumentation, and
 Modelling.
- * Hooks and Scars in the baseline system are suggested to incorporate these technologies in the evolution of the ECLSS.

* Analysis Results

- 1) Automatic Fault Diagnosis of ECLSS Subsystems,
- 2) In-line, Realtime Chemical and Microbial Fluid Analysis, and
- 3) Object-oriented, Distributed Chemical and Microbial Modelling of Regenerative Environmental Control Systems

The ECLSS AAP Evolution & Technology Assessment

1) Automatic Fault Diagnosis of ECLSS Subsystems Description

Description

The ECLSS Software Architecture contains ground based and flight computer software which monitors and diagnoses faults both inside and across subsystems. In the Space Station software environment, these processes can be developed extensively and used on the ground, and migrated to an on-board processor.

The automatic diagnosis software is developed in the ECLSS ground support center. At a sufficient stage (when there is enough computer resource available) the software is migrating on-board, detecting and isolating faults in the process control assemblies of the ECLSS, and recommending recovery action to the crew.

The ECLSS process control environment is extremely applicable, because of its long latency periods, to automatic fault diagnosis and prediction. ECLSS ground support engineers (and computer programs) have a relatively long time to think about faults in the system.

ECLSS Advanced Automation Project

ECLSS Domain Functional Schematic

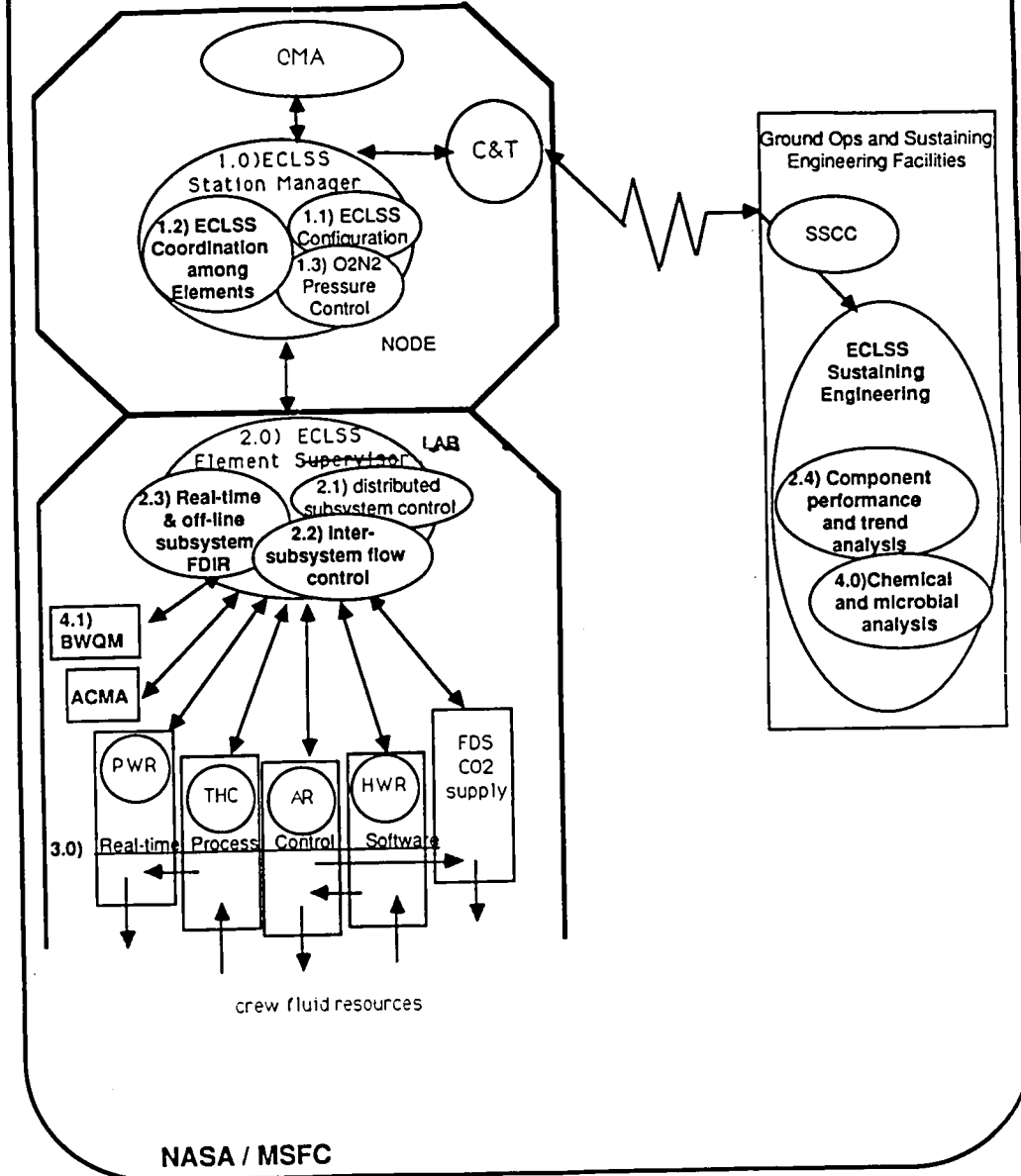

551

The ECLSS AAP Evolution & Technology Assessment

1) Automatic Fault Diagnosis of ECLSS Subsystems Description (continued)

Approach

The ECLSS Advanced Automation Project is currently developing Model Based Reasoning (MBR) software for automatic diagnosis of the ECLSS Potable Water Recovery, Hygiene Water Recovery, and Air Revitalization Subsystems.

Knowledge aquisition for automatic Failure Modes and Effects Analysis (FMEA) will provide failure detection, while MBR will provide the diagnosis and prediction functions.

Design Knowledge of the Space Station ECLS system will be stored using automatic Knowledge Aquisition tools. This knowledge will be useful in augmenting the evolutionary ECLSS and for future environmental control system projects.

The ECLSS Advanced Automation Team is software automation oriented, therefor the applications we chose to automate were software-only or mostly software. But our analysis covered system and process advances, which will need to be addressed for a fully automated ECLSS.

The ECLSS AAP Evolution & Technology Assessment

1) Automatic Fault Diagnosis of ECLSS Subsystems

* Approach

- * Model Based Reasoning (MBR) Diagnosis
- * Automatic Failure Modes and Effects Analysis (FMEA)
- * Design Knowledge Acquisition for Evolutionary ECLSS and future projects
- * Software-only oriented advancements, but in analysis system and process advances were found to be necessary in order to completely automate the flight ECLSS.

2) In-line, Real-time Chemical and Microbial Fluid
Analysis Description

Description

In-line: an automatic part of the fluid recovery loops.

Real-time: constituent data available in seconds.

Provides a running count of a) major Chemical constituents and levels and b) major Microbial constituent levels wherever this smart instrument is hooked into the closed loop fluid system.

This is a difficult but interesting problem that will probably be solved in time to help Space Station ECLSS Evolution, Lunar base, and Mars Mission regenerative environmental control systems.

More complete knowledge of the transitions and interactions which take place in regenerative environmental control systems is necessary to increase the state-of-the-art. Advancements in instrumentation such as this will enhance our analysis and modelling capabilities.

An environmental control system with this degree of regeneration has never been flown before, and the Space Station ECLSS instrumentation must support acquisition of complete fluid constituent data in order to build more robust and autonomous systems in the future.

The ECLSS AAP Evolution & Technology Assessment

2) In-line, Real-time Chemical and Microbial Fluid Analysis

* Description

- * In-line: an automatic part of the fluid recovery loops.
- * Real-time: constituent data available in seconds.
- * Running count of
 - a) major Chemical constituents and levels
 - b) major Microbial constituent levels
- * More smarts in the inline water quality monitor needed to use Space Station Freedom as a testbed for space-based regenerative ECLS systems.

The ECLSS AAP Evolution & Technology Assessment

2) In-line, Real-time Chemical and Microbial Fluid Analysis Description (continued)

Approach

There are three or more implementation possibilities, all involving research in both hardware and software:

- i) Batch Water Quality Monitor Automation
Advanced Mass spectroscopy combined with visual frame microscopic data. Knowledge based systems and/or neural networks may analyze the combined patterns resulting in constituent types and levels.
On the baseline ECLSS, Batch mass spec data along with visual analysis is used by a water quality expert to determine the contents of the water.
This seems like the proper place to start in order to use the components and processes currently in the baseline ECLSS.

ECLSS Advanced Automation Project

Batch Water Quality Monitor Automation

Baselined BWQM Technique

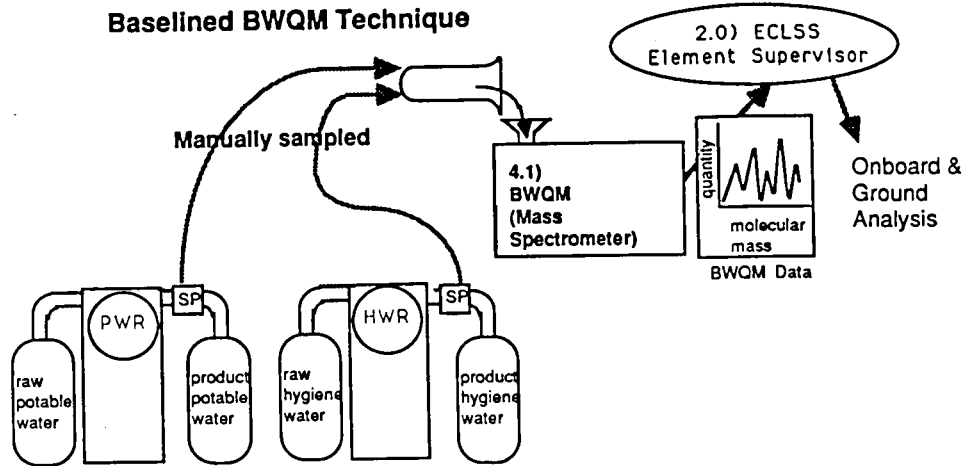

Automated BWQM Technique

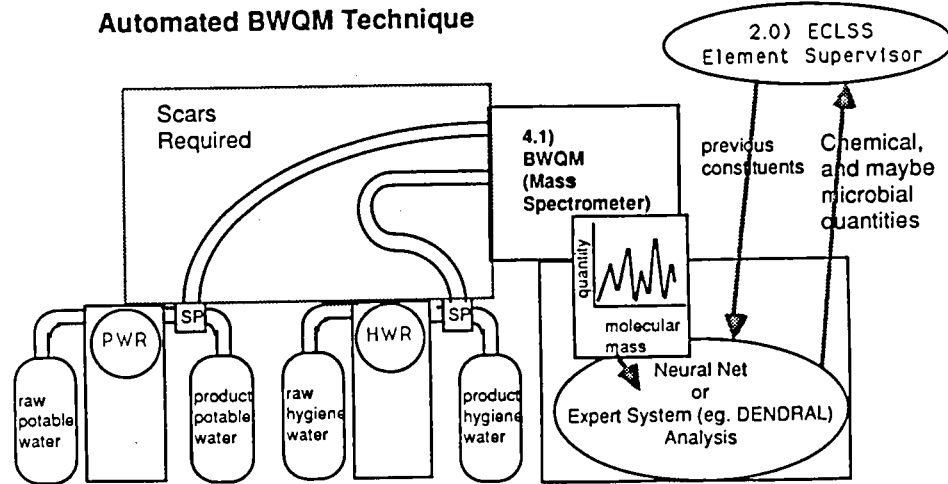

NASA / MSFC

The ECLSS AAP Evolution & Technology Assessment

2) In-line, Real-time Chemical and Microbial Fluid
Analysis Description (continued)

Approachs (continued)

- ii) Flow cytometry analysis with neural network analysis of resulting data is promising candidate technology. Flow cytometry is the process of determining the size and shape of a microbe by the deflections of a lazer through it. Neural networks may be 'trained' to automatically identify up to two dozen microbe types. There has been promising results from this combination of technologies at MIT in their analysis of sea water.

- iii) Enhancements in medical process fluid analysis technologies. Catch-all approach implying that the promising medical technologies emerge daily. This void in automation technology should be filled within the next 10 years and the Freedom Station should be properly prepared to upgrade.

The ECLSS AAP Evolution & Technology Assessment

2) In-line, Real-time Chemical and Microbial Fluid
Analysis (continued)

* Approachs

- ii) Flow cytometry analysis with neural network analysis of resulting data.
- iii) Enhancements in medical process fluid analysis technologies.

**3) Object-oriented, Distributed Chemical and Microbial
Modelling of Regenerative Environmental Control Systems
Description**

Description

Each process in the ECLSS can be thought of as a semi-independent agent with inputs, processing, and outputs.

Independent enhancement of each subsystem may produce undesired or unknown effects on another subsystem or the stability of the entire ECLSS.

A lab is needed in which models and actual assemblies can be integrated, analyzed, verified, and upgraded with new information due to Space Station ECLSS results.

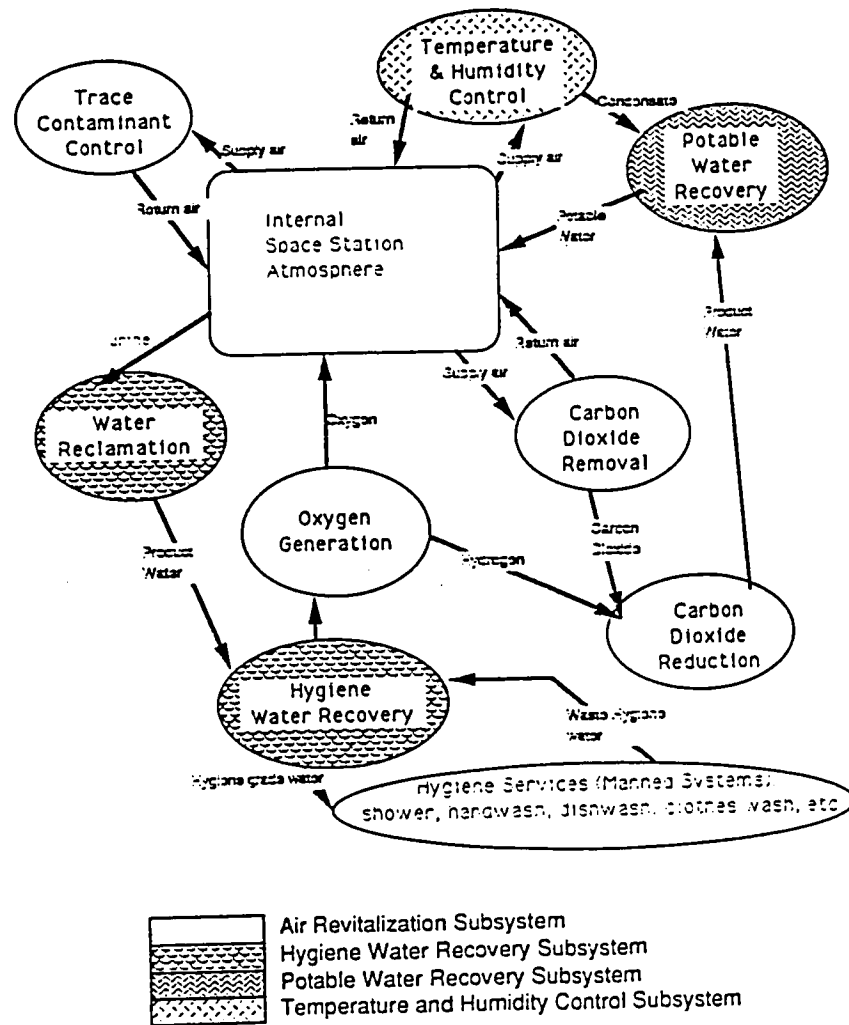

Figure 1 - Regenerative ECLSS Functional Interfaces

The ECLSS AAP Evolution & Technology Assessment

3) Object-oriented, Distributed Chemical and Microbial Modelling of Regenerative Environmental Control Systems Description (continued)

Description (continued)

Inputs, transfer functions, and outputs for each subsystem (including chemical, microbial, and process control data) can be independently enhanced.

New technology subassembly and biological models can be exchanged with the old models to analyze effects.

A network acts as the integrating agent.

Evolutionary Space Station ECLSS, Lunar Base, and Mars Mission regenerative environmental control systems development can use such a modelling system with a closed environment testbed to determine the effects, including chemical and microbial closed loop stability, of implementing:

- Evolutionary Space Station ECLSS process control technologies
- Lunar oxygen mining operations
- Plants and biomass systems

Analysis and modelling of closed loop environmental control systems may enhance our knowledge of, or provide a structure for analysis of, inherent instabilities in the Earth environment.

Approach

Each node in the testbed network can be either a subassembly model or an actual subassembly under test. Shared environmental data can come from the closed environment testbed or model. Subsystem and their models, developed by independent subsystem developers, can be added to the network.

The modelling system should be verified and enhanced in a ground closed environment testbed, and compared with micro-gravity results from Space Station data. Some unexpected chemical and microbial combinations may take place due to changes in fluid mixing behaviors in micro-gravity.

OBJECT MODEL FOR EACH PROCESS
(INCLUDING OPEN ATMOSPHERE AND CREW)

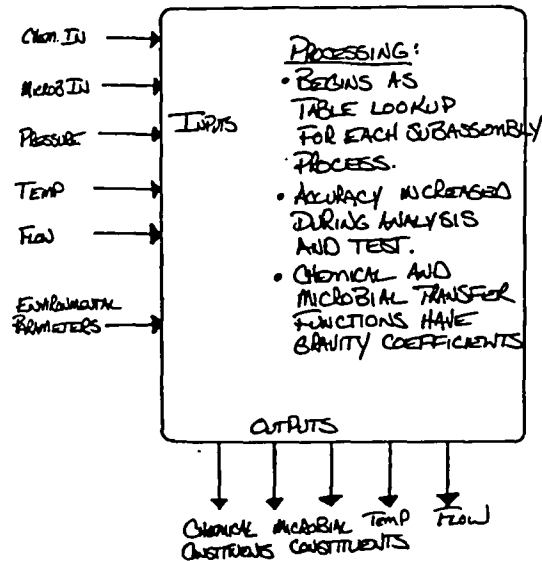

EVOLUTIONARY ECLSS ENGINEERING TESTBED

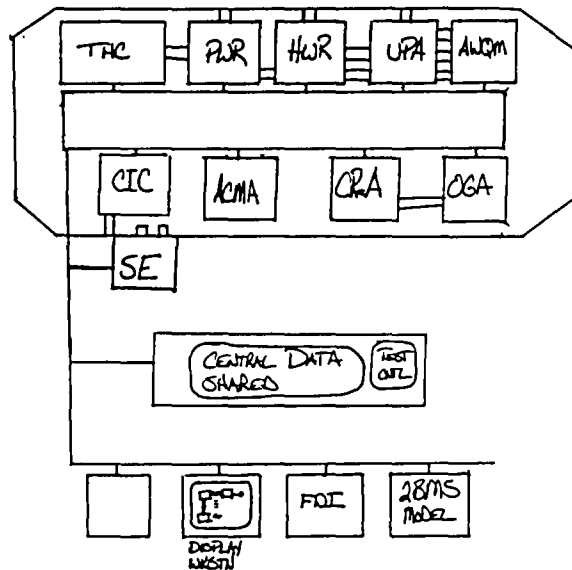

The ECLSS AAP Evolution & Technology Assessment

Conclusion Description

In our Environmental Control and Life Support System automation analysis we found three areas which definitely need further research and development: Automatic fault diagnosis of ECLSS subsystems, in-line real-time chemical and microbial water analysis, and object-oriented distributed chemical and microbial modelling of regenerative environmental control systems.

The Space Station ECLS System should act as a testbed for each of these research areas, as it is for automatic fault diagnosis of process control systems in the ECLSS Advanced Automation Project. Modelling of chemical and microbial closed loop interactions should begin immediately in order that our knowledge may be verified on the ground and on board in time for future missions.

We have entered into an exciting time for man-made regenerative environments. With further research in chemical and microbial interactions, the Space Station environmental control system can be used as a spring board to increase man's knowledge of all existing and envisioned closed environments.

The ECLSS AAP Evolution & Technology Assessment

Conclusion

- * Automatic fault diagnosis of ECLSS subsystems
- * In-line real-time chemical and microbial water analysis, and
- * Object-oriented distributed chemical and microbial modelling of regenerative environmental control systems.
- * The Space Station ECLS System should act as a testbed for each of these research areas.
- * Modelling of chemical and microbial closed loop interactions should begin now.
- * Joint ventures between research centers and development centers are necessary to increase man's knowledge in regenerative environments.