

N 9 3 - 2 7 9 6 3  
97-20

158321

P 14

## AN EVOLUTION STRATEGY FOR LUNAR NUCLEAR SURFACE POWER

Lee S. Mason  
NASA Lewis Research Center

### Abstract

The production and transmission of electric power for a permanently inhabited lunar base poses a significant challenge which can best be met through an evolution strategy. Nuclear systems offer the best opportunity for evolution in terms of both life and performance. Applicable nuclear power technology options include isotope systems (either radioisotope thermoelectric generators or dynamic isotope power systems) and reactor systems with either static (thermoelectric or thermionic) or dynamic (Brayton, Stirling, Rankine) conversion. A power system integration approach that takes evolution into account would benefit by reduced development and operations cost, progressive flight experience, and simplified logistics, and would permit unrestrained base expansion. For the purposes of defining a nuclear power system evolution strategy, the lunar base development shall consist four phases: precursor, emplacement, consolidation, and operations.



## An Evolution Strategy for Lunar Nuclear Surface Power

### Introduction

The production and transmission of electric power for a permanently inhabited lunar base poses a significant challenge which can best be met through an evolution strategy. Nuclear systems offer the best opportunity for evolution in terms of both life and performance. Applicable nuclear power technology options include isotope systems (either radioisotope thermoelectric generators or dynamic isotope power systems) and reactor systems with either static (thermoelectric or thermionic) or dynamic (Bryton, Stirling, Rankine) conversion. A power system integration approach which takes evolution into account would benefit by reduced development and operations costs, progressive flight experience, and simplified logistics, and would permit unrestrained base expansion. For the purposes of defining a nuclear power system evolution strategy, the lunar base development shall consist of our phases: precursor, emplacement, consolidation, and operations.

### Precursor Phase

The precursor phase would precede a human return to the moon and would consist of robotic orbiters or rovers to perform mapping and site selection. Additional distributed experiment packages may be emplaced to gather information on resource extraction potential, and provide engineering data to influence future human missions. Power requirements will range from 100s of watts to several kilowatts per element. Systems will be required to deploy autonomously and tolerate the difficult lunar environment. Other requirements imposed on power systems include that they be lightweight and compact, adaptable to a wide range of applications, and utilize available technology. Power options consist of solar arrays, batteries, fuel cells, and radioisotope systems.

The precursor phase would culminate in a transitional period in which the critical elements required for the first human missions would be verified to confirm performance and reliability. The goal of such a transitional period from the power evolution perspective would be to validate the technologies necessary to achieve at least an order of magnitude increase in power level from those systems employed on initial robotic elements.

An objective in the power system evolution strategy would be to develop a standardized power module as a means of satisfying diverse payload needs while minimizing cost and development. Nuclear systems would be favored for their ability to provide uninterrupted, long lived power. Radioisotope Thermoelectric Generators (RTG) or Dynamic Isotope Power Systems (DIPS) could provide a robust and reliable source for steady-state day and night power while contributing toward an experienced base of operating nuclear systems on the lunar surface. Another advantage of isotope systems is that they are essentially insensitive to the extreme thermal environment over the lunar day/night cycle.

RTGs utilize the natural decay of plutonium-238 as a heat source for thermoelectric conversion to produce electric power. Conversion efficiency is on the order of 5%. RTGs performed extremely well during the five Apollo missions in which they were used. The five SNAP-27 RTGs had an initial power which ranged from 72 to 78 watts with a nominal specific power of 2.3 W/kg. Among the advantages associated with RTGs are long life and space operational experience. *Figure 1* shows the power history of the SNAP-27 RTGs. The current generation of RTGs, the General Purpose Heat Source (GPHS) RTG, provides about 300 We and weighs 60 Kg (5 W/kg) in the configuration used on the Galileo and Ulysses missions. RTGs would be applicable for lunar surface missions when power requirements range from several watts to about a kilowatt.

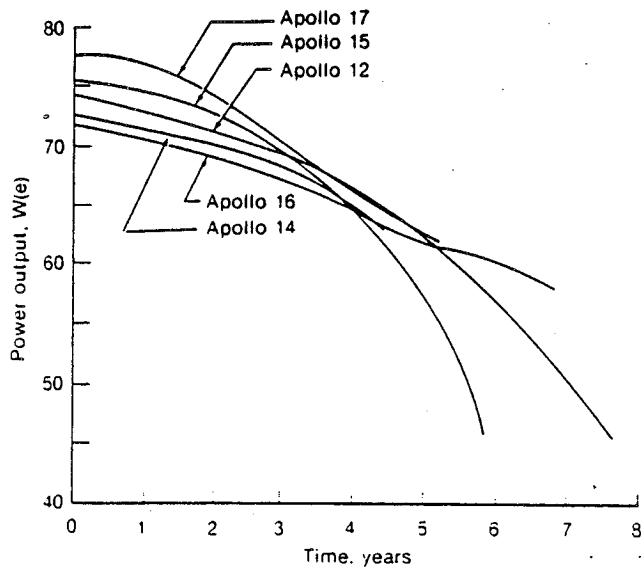

Figure 1. Power History for the SNAP-27 RTGs

DIPS uses this same plutonium heat source but converts the thermal power by means of a heat engine with conversion efficiencies on the order of 25%. The current high cost and scarcity of plutonium-238 makes the higher efficiency of DIPS very attractive. A relative cost comparison between RTGs and DIPS as a function of power level is provided in Figure 2. DIPS could use either Brayton or Stirling cycle conversion. Brayton is a more mature technology option based on the successful testing performed during the 1960s and 1970s. In addition, a 2 kWe solar dynamic ground test demonstration (GTD) program is underway which will utilize Brayton hardware developed in the 1970s. That program intends on refurbishing and testing the Brayton unit in combination with a solar concentrator/receiver and waste heat radiator under prototypic LEO operating conditions. Figure 3 shows a possible Brayton DIPS concept employing a horizontal, flat-plate radiator surface and two heat source assemblies. A Brayton DIPS system similar to that shown in Figure 3 and based on the GTD power converter design would result in a specific power of about 5.3 W/kg at 1 kWe.

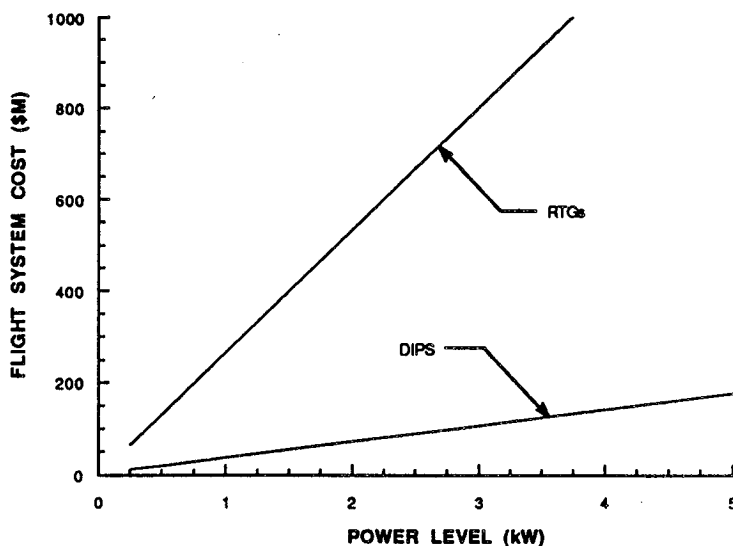

Figure 2. Relative Cost Comparison of RTGs and DIPS

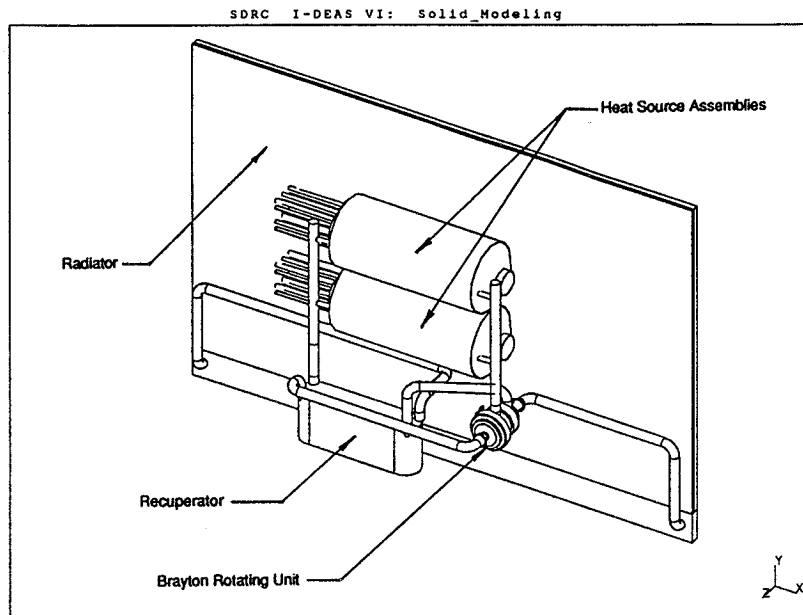

Figure 3. Brayton DIPS Concept

### Emplacement Phase

The emplacement phase would initiate with the first human return to the moon. The outpost will at first resemble a modest "campsite" and not extend far beyond what was achieved on the Apollo missions. The goal of the emplacement phase will be to deliver those elements which would enable a human stay through the lunar night. The first lunar outpost might consist of a crew habitat located on a cargo lander and a series of teleoperated and crew transport rovers as well as additional science and in-situ resource utilization (ISRU) packages. Power requirements are likely to be in the 5 to 25 kilowatt range. Power systems will be required to be lightweight, easily deployable, and highly reliable. Options include photovoltaic/regenerative fuel cell (PV/RFC) systems, DIPS and small nuclear reactor systems. Nuclear systems offer a modest mass advantage over PV/RFC systems in this power range

A modular power system concept would offer the greatest flexibility and growth potential while minimizing cost. A potential scenario for accomplishing this objective is through a multi-purpose mobile power utility cart. In an attempt to maximize return on initial investment, preference would be given to those systems or technologies which were successful in the precursor phase. DIPS technology used on precursor missions could easily be extended to the multi-kilowatt range. The advantage of DIPS over electrochemical systems such as batteries and fuel cells is that no recharging is required. As operating time is increased, the electrochemical system's mass increases substantially as shown in *Figure 4*. If plutonium availability is a concern, a common Pu-238 heat source canister design could be developed which would allow fuel change-out. In this way, the fuel inventory required of the subsequent higher power DIPS modules could be supplemented by extracting fuel canisters from earlier precursor units. A similar operations approach was used for the Apollo RTGs when the isotope fuel was carried separate from the converter in order to simplify in-transit cooling and inserted by astronauts after landing.

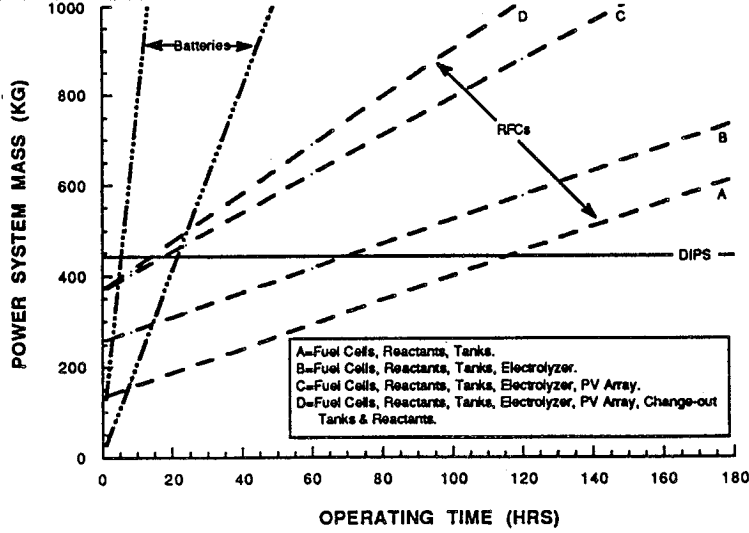

Figure 4. Comparison of Power System Options for 2.5 kWe

If power requirements are closer to 25 kWe, then consideration should be given to a small nuclear reactor system. In this case, development risk could be reduced by using the same power conversion technology that was used with success in the earlier isotope power systems. A modular nuclear reactor system combined with a dedicated rover platform and integral radiation shield could easily meet emplacement phase power requirements while minimizing on-site assembly. A concept for a reactor combined with Brayton cycle conversion is presented in *Figure 5*. The scenario for implementing a system of type is as follows: 1) the cart is off-loaded from the lunar cargo vehicle; 2) the rover is transported via a battery powered cart to a site approximately 1 km from the outpost; 3) a pre-connected transmission cable is unreeled from a cable spool as the cart travels away from the cargo lander; 4) radiator panels are deployed and the reactor power system is activated via earth command; and 5) the cart remains at the site over its service life. The mass of a 25 kW reactor cart was estimated to be about 5 tonnes including the man-rated radiation shield, cart structure, wheels, and battery power source. The advantage of such a system is that it could be readily adaptable to a variety of applications on the lunar surface, and subsequent systems could easily be delivered as required.

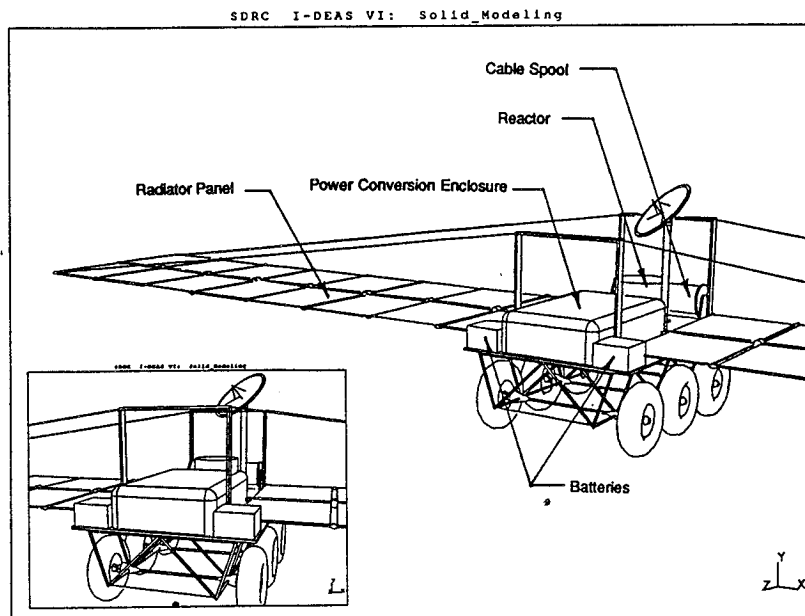

Figure 5. 25 kWe Remotely Deployed Small Nuclear Reactor System

## Consolidation Phase

The consolidation phase should see the emergence of a permanently occupied lunar outpost and an increased reliance on indigenous materials. A variety of resource extraction demonstrations, pilot plants, and science experiments would be established to verify regions of high resource potential. Demonstrations may be performed to investigate the feasibility of utilizing locally derived oxygen and hydrogen for propellant, cast regolith and ceramics for building materials, and He-3 for terrestrial fusion reactors. How-powered distributed experiment packages could be adequately powered by solar arrays, fuel cells, or isotope systems. Higher-powered, remote experiment sites could utilize a minimally shielded small nuclear reactor system. Construction vehicles would be introduced to facilitate the build-up of the lunar base infrastructure. Designs for power systems which could serve multiple distributed loads would be preferred as a way of reducing development, operations, and logistics costs. Power requirements will range from 50 to 100 kilowatts making nuclear reactor systems extremely desirable. Among the power users, a rover and construction vehicle recharging facility would be established to service battery and fuel cell powered vehicles.

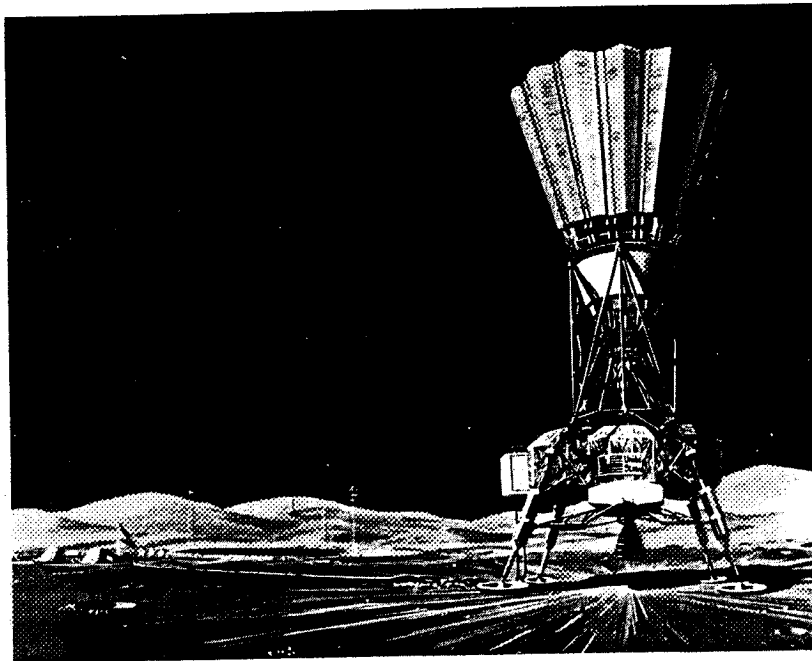

Figure 6. SP-100 Thermoelectric Lander Concept

Expanding human presence might lead to a centralized habitation and activity area and the installation of a power distribution network. At this point in the lunar base development, it might be appropriate to establish a central power system utility site. The first element within the utility site would be required to be easily deployed, reliable, and long-lived. A modular reactor power system combined with a dedicated lunar lander could be utilized to meet these requirements. *Figure 6* shows a concept for a 100 kWe SP-100 thermoelectric power system with a dedicated lander using shaped  $4\text{-}\pi$  radiation shielding. The total landed weight of the thermoelectric lander is approximately 13 tonnes. A similar concept, shown in *Figure 7*, which uses Brayton conversion to supply 100 kWe would weigh about 9 tonnes. The selection of the power conversion technique would depend on how the lunar base was planned to evolve. If multiple, smaller, distributed outposts were planned,

the thermoelectric conversion technology option would be adequate utilizing individual landers at each of the outpost sites. If a single site was selected for full-scale development, dynamic conversion systems would be preferred for their ability to evolve to the multi-hundred kilowatt power plant size.

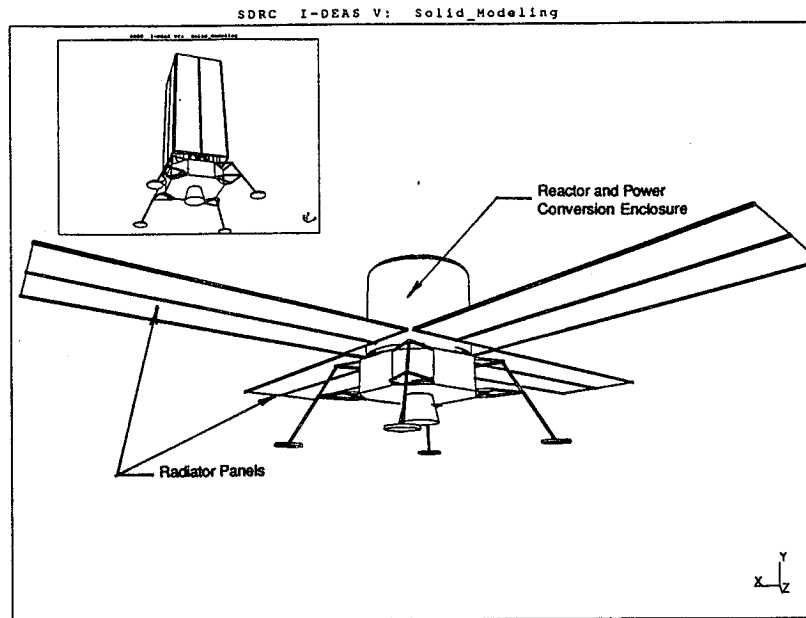

Figure 7. Lander Reactor Power System with Brayton Conversion

### Operations Phase

The operations phase would be marked by a transition to base self sufficiency. Local propellant production would service all ascent and Earth return stages. Base expansion would be expedited by the use of indigenous materials for building structures. Launch and landing services would be expanded to accommodate the beginnings of colonization and the initial exportation of lunar derived resources such as He-3. Power requirements for habitation and resource production are likely to exceed several hundred kilowatts. At these power levels, PV/RFC systems become prohibitive on a mass basis. This is due to the massive energy storage system necessary to supply continuous power through the 354 hour lunar night period. *Figure 8* compares nuclear reactor systems with PV/RFC systems at various night power fractions for power levels up to 550 kWe. The operations phase of the lunar base development would require that nuclear power systems be able to meet changing requirements and accept new loads. Systems would be designed for maintainability, repair, and replacement as a means of extending service life and ensuring proper operation. In order to reduce mass, systems would utilize in-situ materials to the maximum extent possible and take advantage of previously delivered hardware.

The growing lunar base will bring about a need for a substantial rover fleet for crew transport, mining, hauling, construction and science. Mobile power requirements will be driven by operational scenarios and available infrastructure. For vehicles which can return to the central recharging facility, battery and fuel cell power systems will be adequate. For those vehicles which must operate continuously or be capable of extended duration excursions, isotope power systems would be used. RTGs and DIPS could maximize the use of previously delivered Pu-238 fuel by exchanging heat



source canisters as they are needed for various applications.

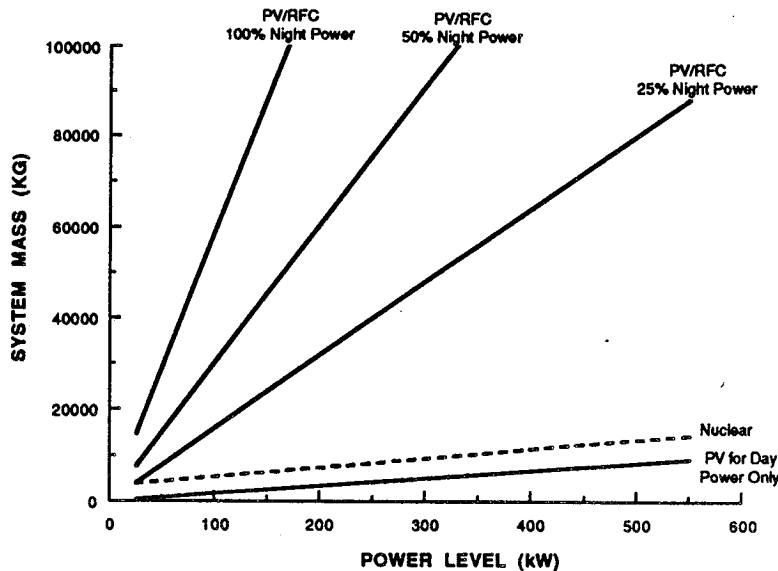

Figure 8. Comparison of Solar and Nuclear Power Systems for Lunar Base Applications

A subsequent, larger reactor power system could be delivered to the central power utility site to compliment and eventually replace the original lander system. An advantage to the central utility approach is that all the reactor systems could be located in a single remote area. This generation of reactor power systems would capitalize on experience gained from previous systems while incorporating technology enhancements such as improved materials for higher temperature operation. This power plant could have excess capacity to accommodate several years of growing power demand and could service the needs of all local lunar elements including habitats, laboratories, resource production plants, launch and landing facilities, and science platforms. Initially, the system could be operated at less than full thermal power and then ramped up to full power as power requirements increase. This strategy offers the potential for extended reactor service life while instilling confidence in system operations through incremental increases in power. The availability of crew members and construction equipment would permit the installation of an erectable reactor power system utilizing lunar regolith for radiation shielding.

Reactor power system design emphasis would be on performance, long life, and operational flexibility. *Figure 9* depicts a nuclear reactor power plant using Stirling conversion to provide as much as 825 kWe. This concept assumes the emplacement of the reactor in an excavation to provide adequate radiation protection for humans. The Stirling engines and radiators are located on the lunar surface and extend radially from the reactor core. A variety of power conversion options could be employed using this design approach. *Figure 10* compares in-core thermionic systems with Brayton and Stirling systems utilizing the SP-100 reactor heat source for 550 kWe. Four thermionic cases are presented with assumptions ranging from conservative to advance with the baseline case being representative of the current Thermionic Fuel Element (TFE) Verification Program. Both a conservative, low temperature case and a more advanced, high temperature case are shown for SP-100 dynamic system options. All systems are within 30% of 12 tonnes for a specific power of about 50 W/kg. In addition to mass there are several other discriminators which will dictate the system

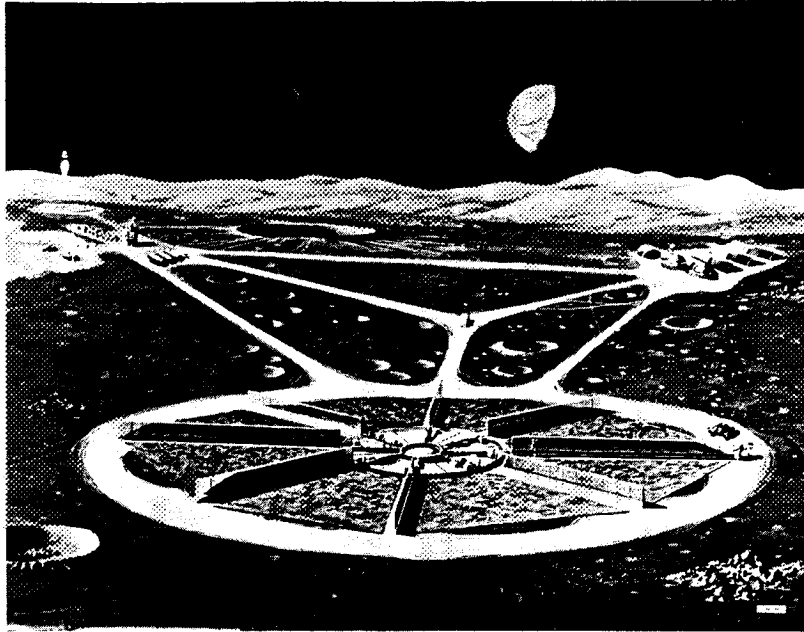

Figure 9. 825 kWe Nuclear Reactor Power Plant with Stirling Conversion

of choice including reliability, life, growth potential, deployability, and maintainability. These characteristics are at least as important as mass from an overall mission perspective.

### Conclusion

The nuclear power system evolution approach described in this paper offers a variety of options and benefits. Nuclear systems offer the greatest advantage in terms of robustness, performance, and growth potential. Early, robotic missions could use RTGs and small DIPS. Initial human missions will take advantage of lessons learned on precursor missions in terms of both engineering data and hardware experience. DIPS could be extended to the multi-kilowatt level or small nuclear reactors deployed remotely by means of a mobile platform could be utilized to meet the initial outpost requirements. As the base matures, a power system network could be established which uses a modular reactor system combined with a lunar lander to serve multiple loads. Subsequent reactor systems will use in-situ materials for radiation shielding and take advantage of the crew and construction equipment for assembly.

The primary benefits to the evolution approach are: 1) reduced development and operations cost; 2) progressive flight experience; 3) simplified logistics; and 4) growth accommodation. These benefits are the result of a logical and rational planning approach. Affordable costs can be maintained by choosing technologies which are capable of meeting the widest range of missions and applications. Each step of the nuclear power system evolution will build on previous successes incorporating technology improvements and greater autonomy. The selection of a common technology with growth potential will ease logistics requirements and expedite lunar base maturation. In addition, the verification of power system performance and reliability on lunar missions will provide the framework for subsequent human missions to Mars.

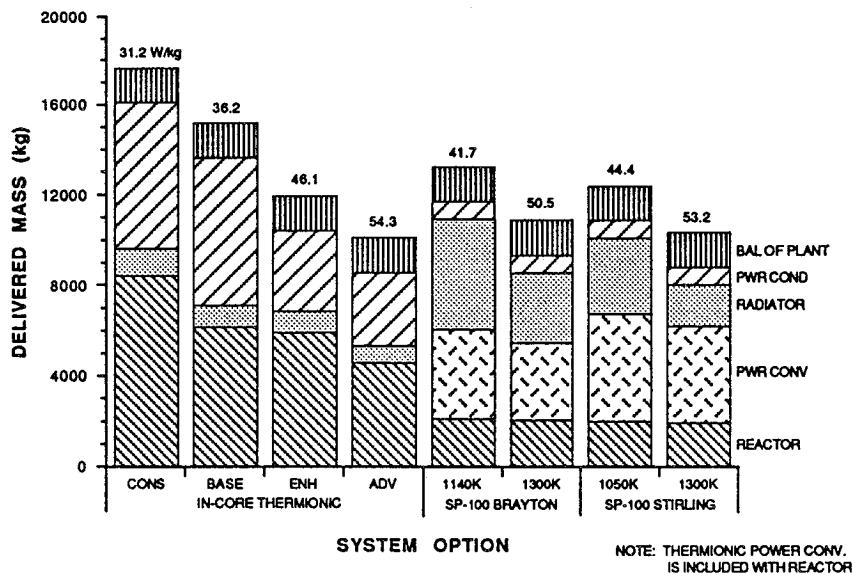
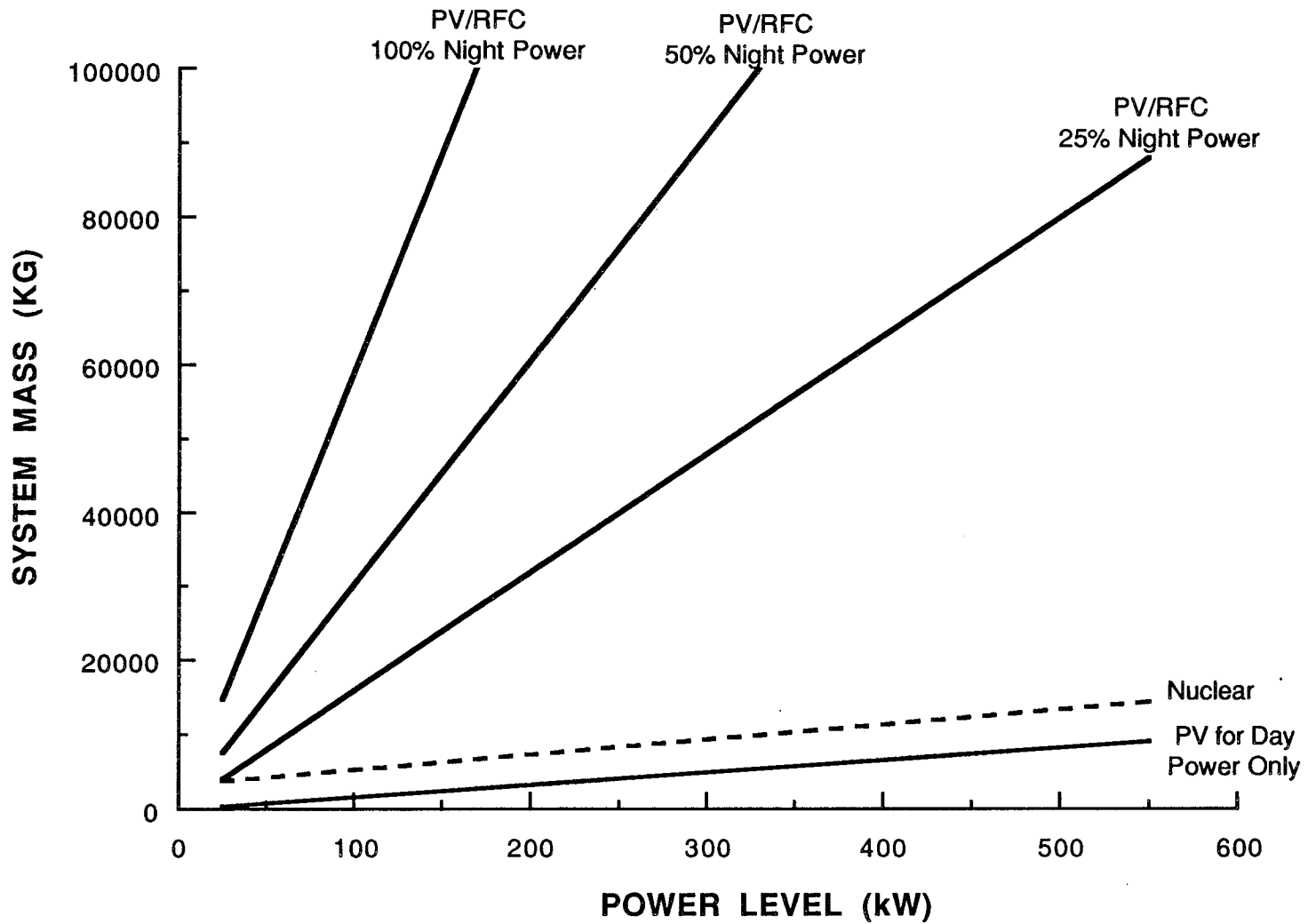
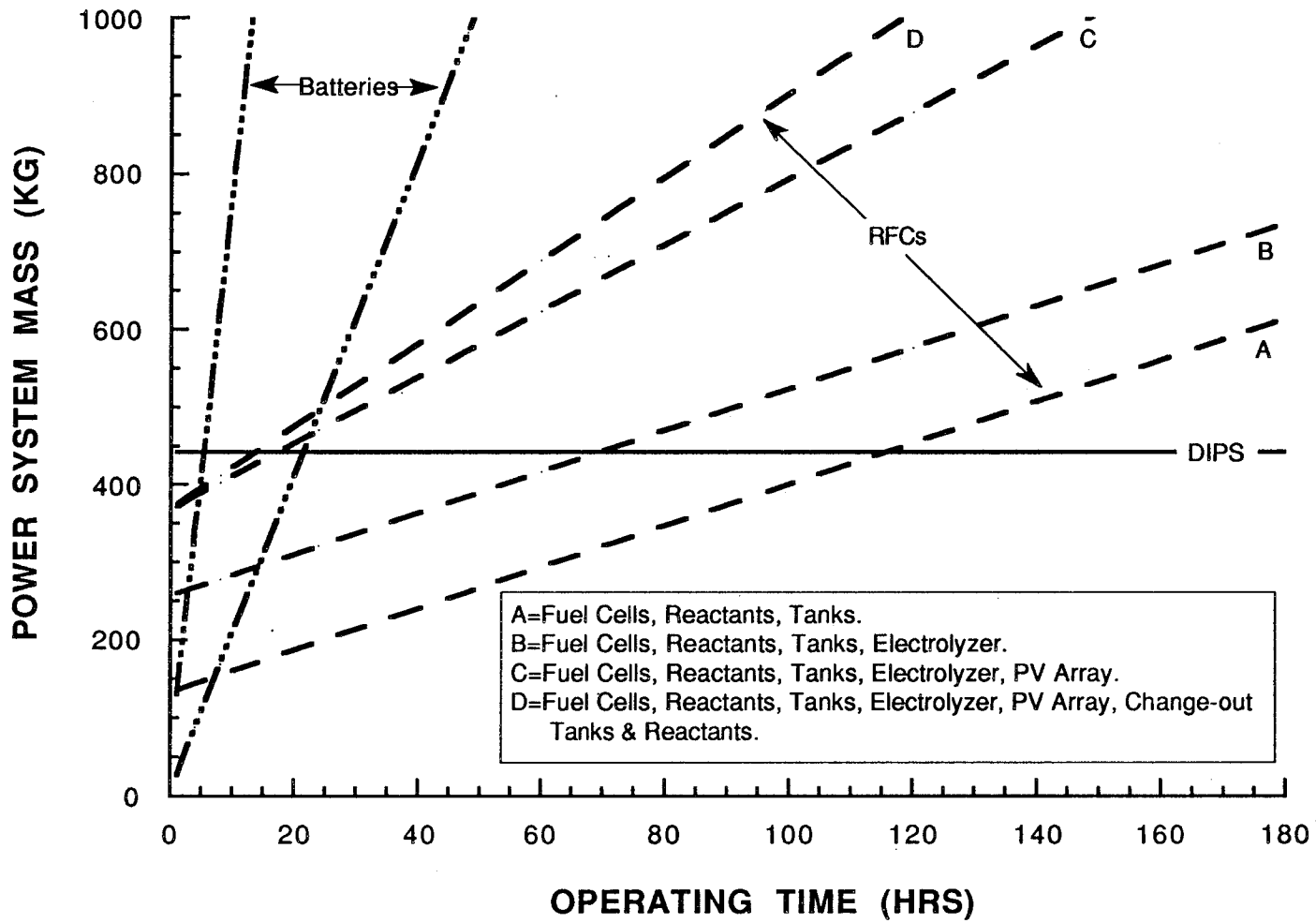

Figure 10. Comparison of Nuclear Reactor Power System Options at 550 kW

### References

1. HICKMAN, J.M., BLOOMFIELD, H.S., *Comparison of Solar Photovoltaic and Nuclear Reactor Power Systems for Human-Tended Lunar Observatory*, NASA TM-102015, August, 1989.
2. MASON, LEE S., BLOOMFIELD, HARVEY S., *SP-100 Power System Conceptual Design for Lunar Base Applications*, NASA TM-102090, January, 1989.
3. PETRI, DAVE A., CATALDO, ROBERT L., BOZEK, JOHN M., *Power System Requirements and Definition for Lunar and Mars Outposts*, prepared for the 25th Intersociety Energy Conversion Engineering Conference, Reno, Nevada, August, 1990.
4. SKRABEK, EMANUEL A., *Performance of Radioisotope Thermoelectric Generators in Space*, prepared for the 7th Symposium on Space Nuclear Power Systems, Albuquerque, New Mexico, January, 1990.
5. MASON, LEE S., SCHMITZ, PAUL C., GALLUP, DONALD R., *Lunar In-Core Thermionic Nuclear Reactor Power System Conceptual Design*, prepared for the 8th Symposium on Space Nuclear Power Systems, Albuquerque, New Mexico, January, 1991.
6. SCHMITZ, PAUL C., MASON, LEE S., *Space Reactor/Stirling Cycle Systems for High Power Lunar Applications*, NASA TM-103698, January, 1991.
7. MASON, LEE S., et. al., *SP-100 Reactor with Brayton Conversion for Lunar Surface Applications*, NASA TM-105637, January, 1992.





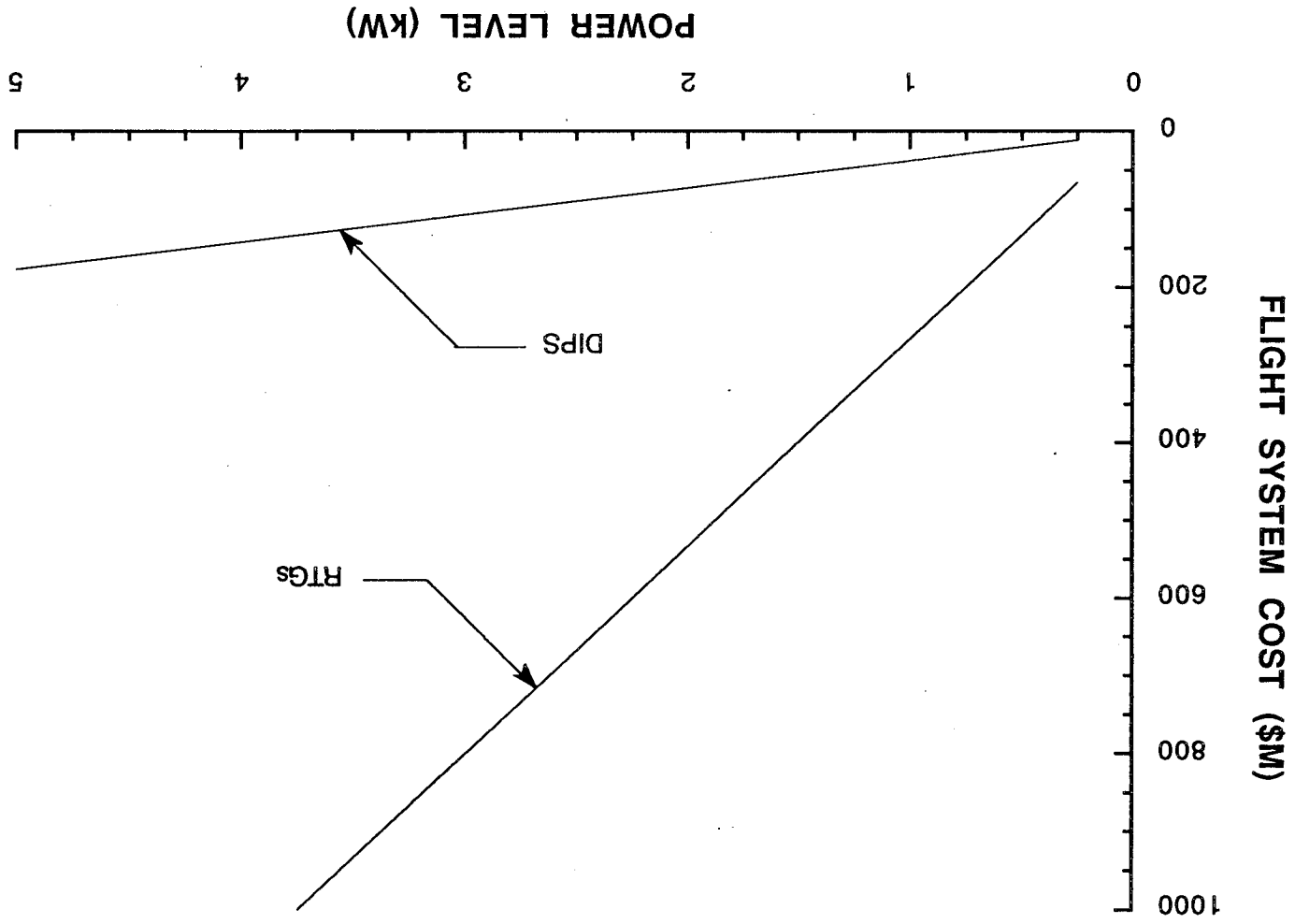

NOTE: THERMIONIC POWER CONV.  
IS INCLUDED WITH REACTOR.

SYSTEM OPTION

