

SPACE ENVIRONMENTAL EFFECTS ON LDEF COMPOSITES: A LEADING
EDGE COATED GRAPHITE EPOXY PANEL

Pete E. George

Boeing Defense and Space Group
Seattle, Washington 98124-2499 M/S 73-09
Phone: 206/234-2679, Fax: 206/237--0052

Harry W. Dursch

Boeing Defense and Space Group
Seattle, Washington 98124-2499 M/S 82-32
Phone: 206/773-0527, Fax: 206/773-4969

Sylvester G. Hill

Boeing Defense and Space Group
Seattle, Washington 98124-2499 M/S 82-32
Phone: 206/773-2767, Fax: 206/773-2767

SUMMARY

The electronics module cover for the leading edge (Row D 9) experiment M0003-8 was fabricated from T300 graphite/934 epoxy unidirectional prepreg tape in a $(0_2, \pm 45, 0_2, \pm 45, 90, 0)_s$ layup. This 11.75" x 16.75" panel was covered with thermal control coatings in three of the four quadrants with the fourth quadrant uncoated. The composite panel experienced different thermal cycling extremes in each quadrant due to the different optical properties of the coatings and bare composite. The panel also experienced ultraviolet (UV) and atomic oxygen (AO) attack as well as micrometeoroid and space debris impacts.

An AO reactivity of 0.99×10^{-24} cm³/atom was calculated for the bare composite based on thickness loss. The white urethane thermal control coatings (A276 and BMS 10-60) prevented AO attack of the composite substrate. However, the black urethane thermal control coating (Z306) was severely eroded by AO, allowing some AO attack of the composite substrate. An interesting banding pattern on the AO eroded bare composite surface was investigated and found to match the dimensions of the graphite fiber tow widths as prepregged. Also, erosion depths were greater in the darker bands.

Five micrometeoroid/space debris impacts were cross sectioned to investigate possible structural damage as well as impact/AO interactions. Local crushing and delaminations were found to some extent in all of the impacts. No signs of coating undercutting were observed despite the extensive AO erosion patterns seen in the exposed composite material at the impact sites.

An extensive microcrack study was performed on the panel along with modeling of the thermal environment to estimate temperature extremes and thermal shock. The white coated composite substrate displayed almost no microcracking while the black coated and

bare composite showed extensive microcracking. Significant AO erosion was seen in many of the cracks in the bare composite.

INTRODUCTION

The Long Duration Exposure Facility (LDEF) was deployed on April 7, 1984 in low earth orbit (LEO) at an altitude of 482 kilometers. During the 5.8 year mission the LDEF experienced LEO environment conditions including atomic oxygen (AO), ultraviolet radiation (UV), thermal cycling, and micrometeoroid/space debris impacts. The LDEF was retrieved on January 12, 1990 from an altitude of 340 kilometers. The higher AO concentrations at lower altitudes resulted in most of the total AO fluence occurring late in the mission.

One of the experiments on board was M0003 "Space Environment Effects on Spacecraft Materials" from the Aerospace Corporation. As a sub set of the experiment the Boeing Defense and Space Group flew a number of organic composite specimens (M0003-8) most of which have been tested and the results presented elsewhere (refs. 1,2).

A portion of experiment M0003-8 flew on the leading edge of the LDEF at position D9 as shown in Figure 1. Included in this experiment was an electronics module cover fabricated from T300 graphite/934 epoxy. This panel, shown in Figure 2 in postflight condition, consisted of 20 plies layed up at $(0_2, \pm 45^\circ, 0_2, \pm 45^\circ, 90, 0)_S$ and autoclave cured at 350°F.

The panel was coated with thermal control coatings in three of the four quadrants. The white thermal control coatings (BMS 10-60 and A -276) contained a titanium dioxide pigment while the black coating (Z306) contained carbon. All the coatings had a polyurethane matrix. The fourth quadrant was left bare to allow direct exposure of the composite substrate. One inch diameter mounting washers located at the corners and along each side shielded the underlying composite and coating. These shielded areas are apparent in Figure 2 as circular areas in the corners and along the sides of the panel. The shielded areas provided control surfaces for erosion measurement. Figure 3 shows the three thermal control coatings along with the relative orientation of the panel to the spacecraft .

A summary of the environmental conditions for the composite panel is listed in Figure 4. The AO and UV exposure levels were among the highest of the experiment positions on LDEF (Refs. 3,4). Thermal cycling was predicted based on the pre and postflight optical properties of the coatings and pre and post flight properties of the bare composite along with exposure conditions and thermocouple data from an aluminum plate located beneath the composite panel. Thermal cycle modeling details are discussed in the microcrack study section of this paper.

OBJECTIVE

Based on lessons learned from investigation of the other organic composite specimens flown on M0003-8 a test plan was developed for the coated panel. AO erosion, micrometeoroid and debris impacts and thermal cycle induced microcracking were found to present the greatest threat to the performance of organic matrix composites in LEO. These environments impact dimensional stability, mechanical stiffness and strength, and optical properties of uncoated organic matrix composites.

Another LEO environmental effect worth investigation is outgassing effects on dimensional stability. These properties are best investigated by insitu measurement of dimensional change vs. LEO exposure time and conditions as performed by Tennyson (Ref. 5). The M0003-8 composite specimens were not strain gauged during flight and the outgassing-dimensional change relationship has been found to be reversible (Ref.5). Therefore those effects were not investigated here.

AO erosion appears to be the most detrimental environmental effect on uncoated organic composites. Quantification of the erosion level on the bare quadrant of the T300 graphite/934 epoxy panel was a top priority. Also, some interesting "band patterns" were apparent in the AO eroded surface of the bare composite. Measurements were made on the size and spacing of the bands in an attempt to determine their origin.

Micrometeoroid/debris impacts on the composite panel left visible signs of damage on the surface including removal of protective coatings. The majority of the visible impacts on the composite panel occurred in the white A276 coated quadrant. The five largest impacts in that quadrant were cross sectioned and polished for coating and substrate damage evaluation.

Three different thermal control coatings were applied to the composite panel prior to flight. The coatings provided different levels of protection against thermal shock based on their optical properties. The thermal cycling and thermal shock levels for the coated composite panel and bare composite panel areas were modeled based on available temperature data and the known optical and physical properties of the panel and coatings. This data was evaluated in conjunction with a detailed microcracking study to determine the possible existence of a thermal cycling/microcracking correlation. Polished sections containing microcracks were also examined for evidence of microcracking/AO erosion interaction.

ATOMIC OXYGEN EROSION

Test Method

AO erosion of the bare T300 graphite / 934 epoxy panel was measured by comparing the eroded surface to an adjacent area where the original surface was protected by a mounting washer. A Cyber Optics Cyberscan 2000 laser profilometer was used to measure the distance from the protected to the eroded surface. Line scans across the step were performed in six locations. A step size of 0.0005 inch was used with a 0.00003 inch depth resolution. The measured erosion depths were based on data outside a 0.030 inch buffer zone centered on the transition from protected to eroded surfaces. This eliminated any transition effects of possible shadowing from contributing to the erosion depth measurement.

Results

An average thickness loss of 0.00339" of composite material was measured. Using this material loss with the AO exposure conditions shown in Figure 3, a 0.99×10^{-24} cm³/atom reactivity was calculated for the T300 graphite / 934 epoxy uncoated area. This value compares favorably with other reported reactivities for T300 graphite / 934 epoxy specimens flown on LDEF. The white coated quadrants did not experience any erosion of the composite substrate due to AO shielding by the AO stable titanium dioxide pigment.

The black coating was severely eroded as both the carbon pigment and the polyurethane matrix reacted with AO. Some initial attack of the substrate under the black Z306 coating was apparent.

Figure 5 is a 3-D plot of the data collected during a laser profilometry raster scan of a partially coated T300 graphite/934 epoxy panel segment. Data is plotted as a 0.0005" grid for the x-y plane and 0.001" line segments of various thicknesses for the z-direction (depth). The approximately 1 inch square area contains a circular region shielded from AO attack by a mounting washer on the surface. An A276 white polyurethane coating covers the rear left half of the panel segment.

There are three distinct height levels in this plot representing (from highest to lowest) the coating surface, the original uncoated composite surface (semicircular disk), and the AO eroded composite surface. The outline of the mounting washer can be seen on the coating surface where approximately 0.002" of coating was eroded beyond the washer protected area. On the uncoated composite half of the segment the washer protected area is easily detectable as a 0.003" step between the AO eroded surface and the original bare composite surface. The original coating thickness of 0.002" can be seen between the original uncoated composite (semicircular disk) surface and the coating surface.

Other visible features include a micrometeoroid or debris impact on the coated surface just to the left of the washer protected area and vertical spikes rising from the AO eroded composite surface due to particulate contaminate AO shielding.

Band Patterns

Just in front of the semicircular original uncoated composite surface shown in Figure 5 are some periodic height variations in the AO eroded composite surface. These variations correspond to a light and dark banding pattern that has also been reported for other leading edge exposed graphite/epoxy surfaces (Ref. 6). The light and dark bands were visible on the AO eroded bare graphite/epoxy surface as shown in Figure 6. Laser profilometry and physical measurements of the bands were taken to determine their width and height. The profilometry data revealed a height of approximately 0.0005" of the lighter bands over the darker bands. A width of 0.059 ± 0.003 " was measured for 10 separate bands indicating fairly uniform width from band to band. This width compares closely to the 0.056" average width for as prepregged T300/934 epoxy 3K graphite tows (18 tows or graphite fiber yarns per inch of T300/934 prepreg tape). Therefore the banding pattern shown on this panel is most likely due to a tow to tow material variation. The lighter color of the higher bands corresponds to a higher level of "ash" material as observed with optical microscopy. This "ash", which has been reported to contain sodium sulfate based on chemical analysis (Refs. 1 and 2), may have provided some shielding which would account for the reduced erosion of the lighter bands.

IMPACT CROSS SECTIONING

The five most prominent impact sites in the graphite/epoxy panel were cross sectioned to investigate coating and substrate damage. These impacts were all located in the A276 coated quadrant of the panel and had penetrated the coating, exposing the composite substrate. AO erosion of the exposed composite was visible with the unaided eye and its possible interactions with the impact geometry and damage were also investigated.

Sample Preparation

In order to preserve the impact damage and delicate AO erosion features including possible under cutting of the coating the impact sites were protected prior to rough trimming of the panel by placing a drop of low viscosity optical quality epoxy resin on their surfaces. The sites were under microscopic observation during this process and no flaking or movement of material other than some loose pigment particles from adjacent surfaces was seen.

After abrasive water jet trimming the preserved impacts were mounted in an epoxy casting for sectioning. The mounts were then trimmed using a liquid cooled abrasive cutting wheel to within approximately 0.1" of the impact. The remaining material was removed by polishing to reach the center line of the impact. Four of the impacts were sectioned in the 90° direction and one in the 0° direction.

Impact Observations

The polished cross sections were then examined at various magnifications using a Zeiss Axomat microscope with bright field illumination. Figures 7 through 11 are photomicrographs of the polished cross sections for impacts one through five respectively. These impacts have many of the same features along with some distinct dissimilarities. Four of the five impacts display an inverted hat shape (three very strongly). These four impacts (numbers 1,2,3 & 5) also display AO erosion features which are approximately 3 to 4 fiber diameters tall both on the "shoulders" and at the "base" of the hat (See Figure 12). Impact number four, which does not have the inverted hat shape, displays extensive crushing and displacement of material. Also, its erosion features are only one fiber diameter tall.

All impact sites displayed delaminations at the first ply orientation transition interface. Only the largest impact, #5, displayed deeper delaminations. Impact #5 also contains what appear to be fiber fractures below the base of the impact. These were initially thought to be polishing artifacts. However, after repolishing and observing using a differential interference contrast technique the fractures were still present and an indication of depth to the fractures visible (see Figure 13). No indications of coating undercutting by AO were visible.

MICROCRACKING STUDY

Thermal Modeling

The epoxy/graphite composite substrate experienced different thermal extremes and thermal shocks in the four quadrants based on the optical properties of the coatings. These cycles and extremes were estimated using LDEF environmental data (ref. 4), coating and composite physical and optical properties, and recorded flight data for temperature vs. time of an aluminum plate which was located beneath the coated panel. The results are shown graphically in Figure 14 as temperature vs. time for 2 cycles. As was expected, the thermal cycle shock and extremes were much greater for the Z306 black coated and uncoated composite quadrants than for the A276 and BMS 10-60 white coated composite quadrants.

Microcrack Density Measurements

Six specimens were taken from each quadrant at 0°, +45° and 90° (2 each) for cross sectional microcrack analysis. A total of 48 lineal inches of cross section, twelve from each

quadrant, were examined by optical microscopy at 200x magnification for microcrack location and density. A summary of the results is presented in Figure 15. The black coated and bare quadrants contained significant levels of microcracking while the white coated quadrants were relatively crack free. Most of the cracks that were found in the white coated specimens were located within close proximity to the black or bare area boundaries. The more extreme thermal environment experienced by the black coated and bare quadrants appears to have created thermal stress induced microcracking in those areas as well as in adjacent regions of the white coated quadrants.

Undoubtedly other factors came into play during microcrack formation. The panel was restrained by the mounting points possibly interfering or aggravating the thermal expansion or contraction of the panel. AO erosion, which may have provided possible crack initiation sites in the black and bare coated quadrants, basically removed one ply from the bare quadrant creating an unbalanced layup. Finally, the heating and cooling from direct and reflected solar radiation occurred on one side of the panel possibly creating a significant thermal gradient through the thickness of the panel. Indeed there is more cracking in the exposed outer three plies than the shielded inner three plies for all the quadrants. The white coatings did adequately minimize thermal stresses in their quadrants to effectively prevent substrate microcracking. However, due to the complexity of the thermal stresses experienced by the panel, extracting quantitative design data from these results would be challenging.

Microcrack-Atomic Oxygen Interaction

AO interaction with microcracks was observed in both bare and coated areas. Figure 16 shows a microcrack in the surface ply of the bare composite quadrant. The upper portion of the crack has been enlarged by AO attack. This interaction was found in two thirds of the observed surface ply cracks for the bare quadrant. Figure 17 shows similar interaction for a crack in the black coated quadrant. Note that AO attack has begun in the composite substrate in some regions where the coating has been completely eroded. As mentioned above the AO erosion may have also created crack initiation sites. The AO created sharp erosion troughs running parallel to the fiber direction.

AO-microcrack interaction was also observed for a crack in the A276 white coated region. Figure 18 shows a thermal cycle induced microcrack in the surface ply of the A276 coated quadrant. Careful observation reveals that the crack has propagated through the coating allowing limited AO attack of the substrate. The coating breach, which is visible with the unaided eye on the panel surface, was present during flight as evidenced by the signs of AO erosion in the crack. Crack propagation through the A276 coating was unexpected as the coating has a strain to failure of 30-50%. The limited AO erosion in the substrate microcrack suggests that propagation through the coating occurred later in the mission. The substrate crack which would have developed before most of the AO exposure may have created stresses in the coating which accelerated AO attack of the coating over the crack.

CONCLUSIONS

Atomic Oxygen Exposure

Response to low earth orbit atomic oxygen exposure varied for the different panel quadrants. The AO reactivity of the uncoated T300 graphite / 934 epoxy composite quadrant was measured to be $0.99 \times 10^{-24} \text{cm}^3/\text{atom}$. This value agrees favorably with

other reported AO reactivities for T300 / 934 flown on LDEF. The Z306 black urethane coating did not prevent AO attack of the graphite epoxy. Further exposure would have completely removed the coating, allowing unhindered attack of the substrate.

Both the A276 and BMS 10-60 white urethane coatings effectively protected the graphite/epoxy from attack. This is due to the AO resistant nature of the titanium dioxide pigment in these coatings. The only AO attack of the white coated composite substrates occurred where the coatings had been breached by either an impact or a surface microcrack propagating from the black coated or bare composite areas.

Light and dark bands were observed on the surface of the uncoated composite region. Using optical microscopy and profilometry the light bands were found to be approximately 0.005" taller than the dark bands and contained a higher level of "ash" giving them their lighter appearance. The band widths closely match the widths for as prepregged 3K T300 graphite/934 epoxy tows. Therefore, the banding appears to be a tow to tow material variation.

Cross sectional analysis of micrometeoroid/debris impact sites provided direct observation of the damage to the coating and composite substrate. Local delaminations and crushing were evident at all observed impact sights. The largest impact site had unexplained fiber damage in the form of fiber cracks running parallel to the direction of the impact. Four of the five impacts displayed an "inverted hat" shape and these four had similar size AO erosion features. The fifth impact did not have the inverted hat shape and had significantly smaller AO erosion features. This impact may have occurred much later in the mission. The inverted hat shape may be due to coating removal around the impact site and/or accelerated AO erosion of crushed composite at the impact center. No signs of coating undercutting were observed at the impact sites.

The quadrants of the graphite/epoxy panel experienced significantly different thermal cycle/shock conditions. The A276 and BMS 10-60 white thermal control coatings effectively prevented microcracking of the composite substrate. The Z306 black urethane and uncoated quadrants experienced hotter thermal cycle extremes and greater thermal shock resulting in significant microcracking of the outer three laminate plies. AO interaction with cracks on the surface ply was observed in the form of crack enlargement. Surface ply cracks extended a short distance from the black coated and uncoated quadrants into the white coated quadrants. Evidence of initial AO attack was seen in one of these cracks indicating that crack propagation through the white coatings occurred during flight.

FUTURE WORK

The reduced AO erosion observed for the the lighter bands on the uncoated composite surface warrants further investigation. Tow to tow variables targeted for investigation include local resin content by cross sectional image analysis and carbon fiber sodium content, one of the elements present in the surface "ash" which has been identified as AO resistant sodium sulfate. These findings may help development of structural composites with inherent AO resistance.

The impact sites have only been examined in one cross sectional plane. Continued sectioning with quantitative geometry measurements will allow a 3-D picture of impact sites to be assembled from slices. This may yield further insights into impact damage and AO impact interactions.

The thermal cycling/microcracking results may offer the most useful information for space composite hardware designers. Adjustment of the thermal cycle calculations for the white coated regions will be necessary due to the temporary UV degradation of optical properties before AO bleaching occurred. CTE measurements of samples from the quadrants may reveal microcrack induced changes. Also, thermal cycling specimens from the white coated quadrants to the same extremes experienced by the black coated and bare quadrants followed by microcrack inspections will help verify the thermal modeling. Finally, incorporation of these results with additional ground based testing and existing work could lead to development of a comprehensive LEO exposure/microcracking model allowing refined prediction of mechanical properties.

ACKNOWLEDGMENTS

The authors would like to thank the Analytical Engineering, Physics, and Structures organizations along with members of the Nonmetallic Materials Technology group of Boeing Defense and Space Group for their assistance.

References

1. George, P.E. and Hill, S.G.; Results from Analysis of Boeing Composite Specimens Flown on LDEF Experiment M0003-8. First LDEF Post Retrieval Symposium, NASA CP-3134, Feb. 1992.
2. George, P.E.; Space Environmental Effects on LDEF Low Earth Orbit Exposed Graphite Reinforced Polymer Matrix Composites. LDEF Materials Workshop 1991, NASA CP-3162.
3. Bourassa, R.J.; and Gillis, J.R.; Atomic Oxygen Exposure of LDEF Experiment Trays. NASA Contractor Report No 189627. May 1992.
4. Bourassa, R.J.; and Gillis, J.R.; Solar Exposure of LDEF Experiment Trays NASA Contractor Report No. 189554. Feb. 1992.
5. Tennyson, R. et al; Preliminary Results From the LDEF UTIAS Composite Materials Experiment. First LDEF Post Retrieval Symposium NASA CP-3134, Feb. 1992.
6. Slemper, W. S. et al; Effects of LDEF Flight Exposure on Selected Polymer Matrix Composite Materials. First LDEF Post Retrieval Symposium, NASA CP-3134 Feb. 1992.

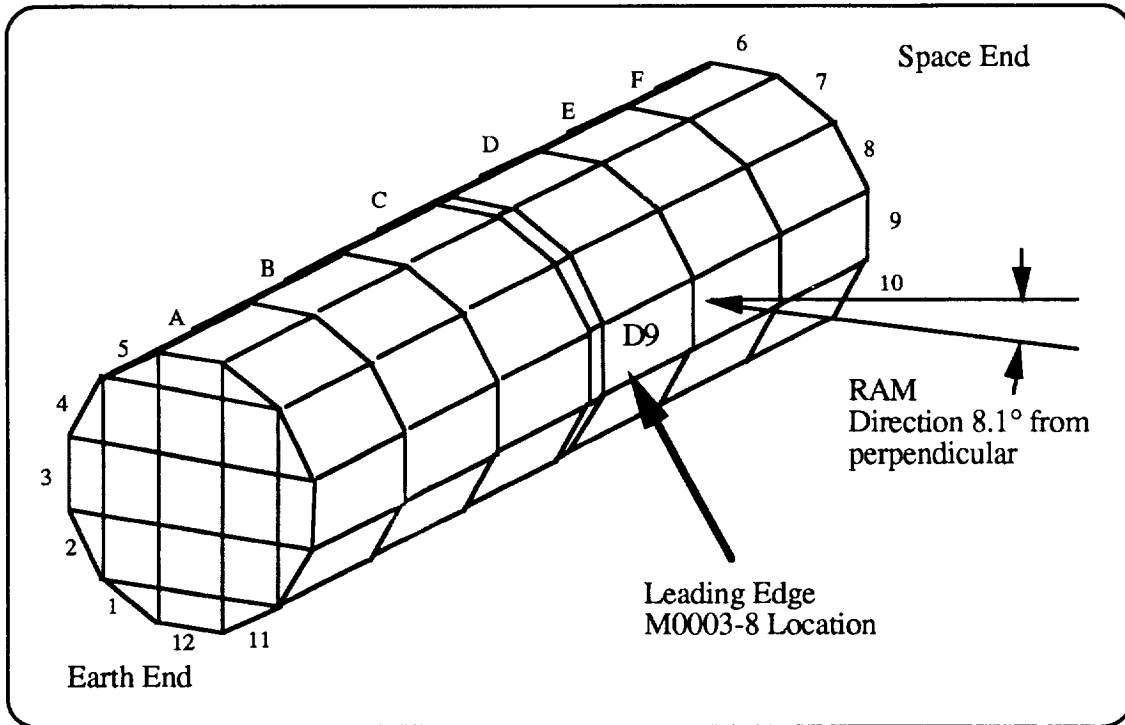

FIGURE I. - LEADING EDGE POSITION OF LDEF EXPERIMENT M0003-8



FIGURE II. - POST FLIGHT PHOTOGRAPH OF COATED T300 GRAPHITE/934 EPOXY TEST PANEL

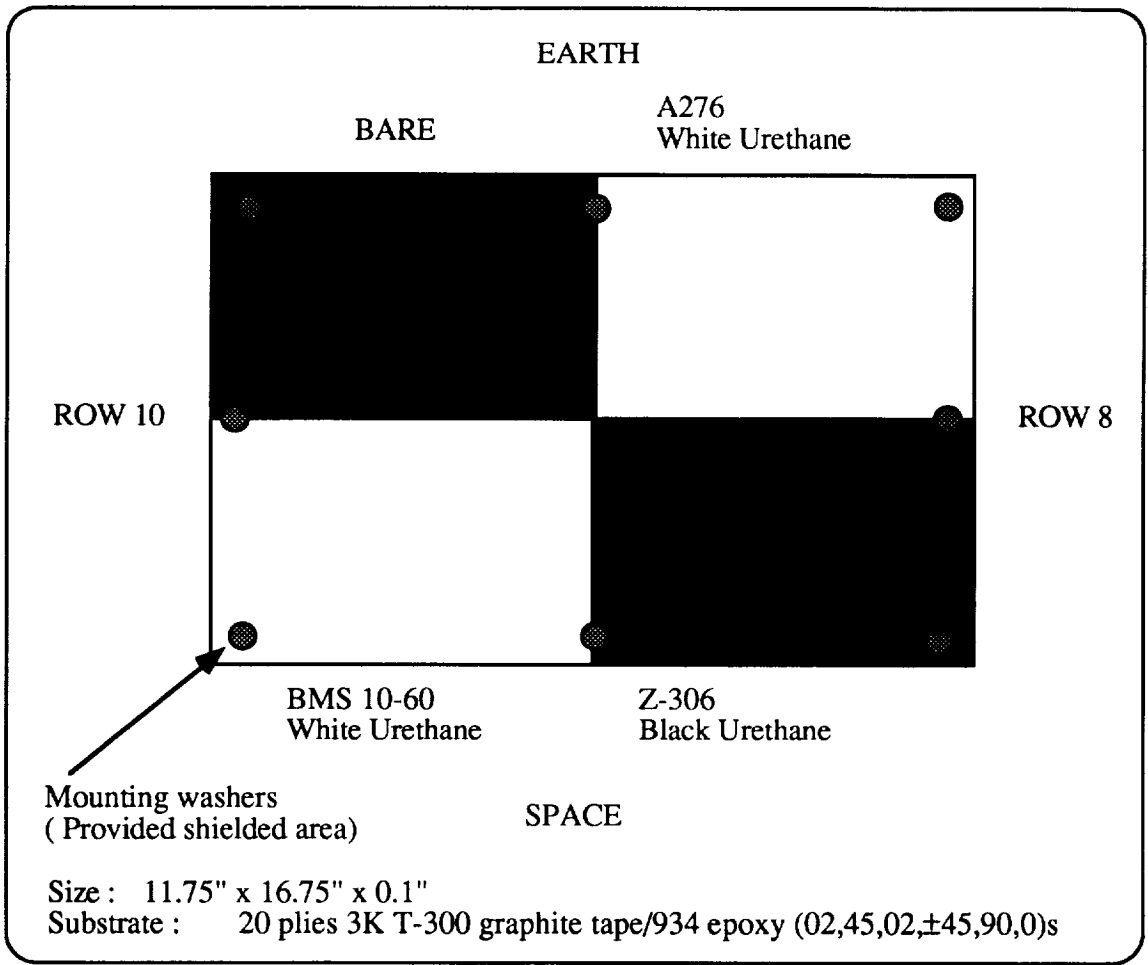

FIGURE III. - DIAGRAM OF COATED T300 GRAPHITE/934 EPOXY TEST PANEL

	LEADING EDGE TRAY POSITION D9			
COATING	Uncoated	Z-306 Black	A-276 White	BMS 10-60 White
ATOMIC OXYGEN EXPOSURE (Impacts / cm ²)	8.72 x 10 ²¹			
INCIDENT SOLAR PLUS EARTH REFLECTED RADIATION (Equivalent solar hours)	11,200			
THERMAL CYCLING (based on modeling and measurements)	-70° to 235°F	-75° to 205°F	-75° to 60°F	-75° to 60°F
	34,000 CYCLES			

FIGURE IV - EXPOSURE CONDITIONS FOR M0003-8 COATED T300 GRAPHITE/934 EPOXY TEST PANEL

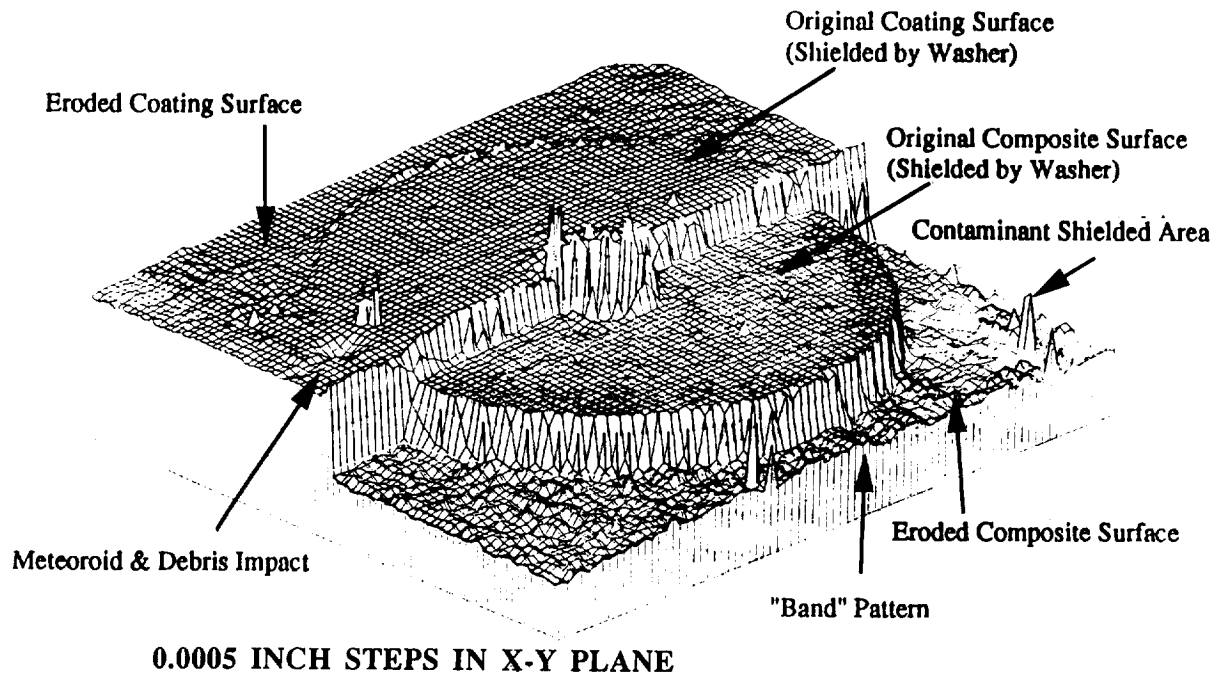

FIGURE V - LASER PROFILOMETRY RASTER SCAN OF WASHER REGION

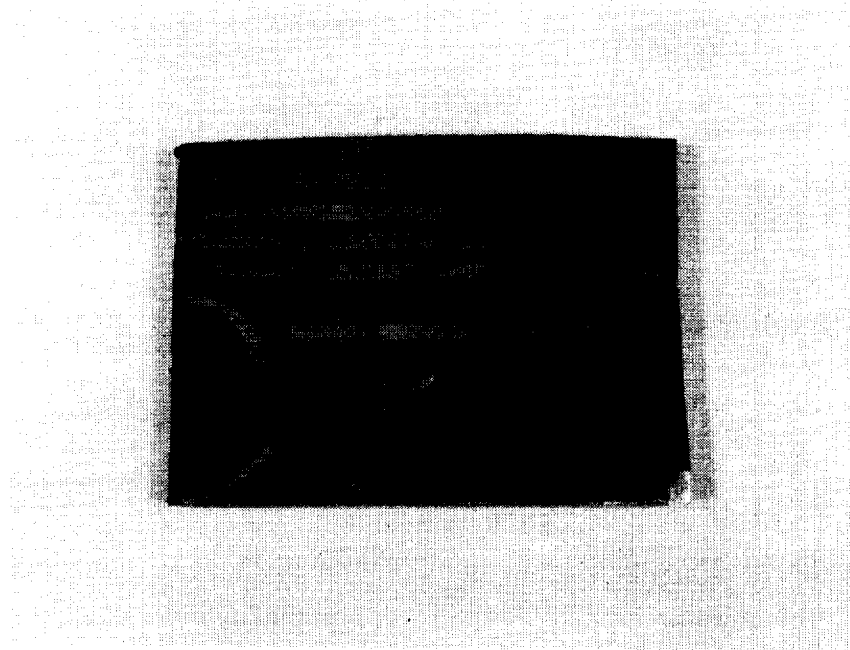

FIGURE VI - PHOTOGRAPH OF BAND PATTERN ON EXPOSED UNCOATED T300 GRAPHITE/934 EPOXY SURFACE



FIGURE VII - CROSS SECTIONAL PHOTOMICROGRAPH OF IMPACT #1 IN A-276 COATED T300/934

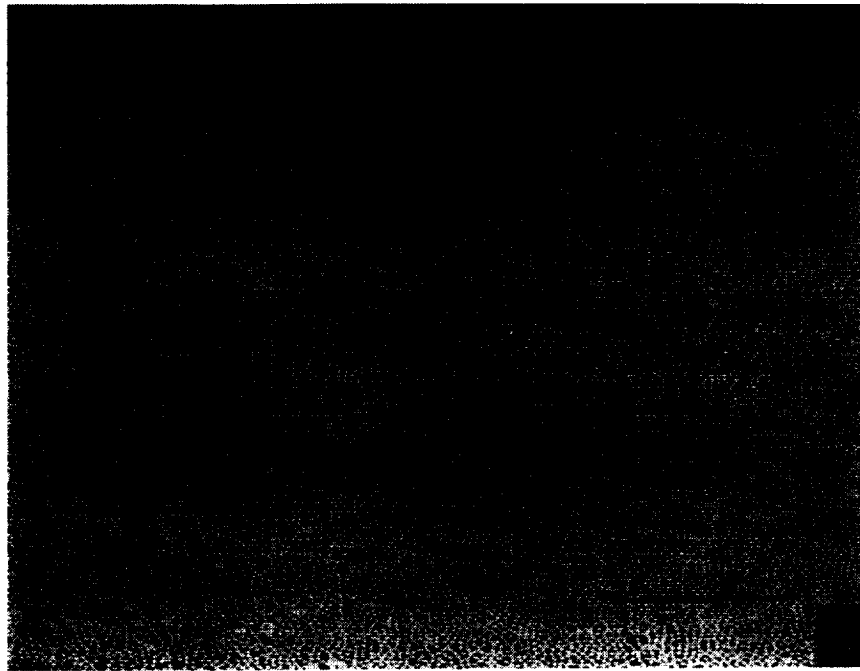

FIGURE VIII - CROSS SECTIONAL PHOTOMICROGRAPH OF IMPACT #2 IN A-276 COATED T300/934

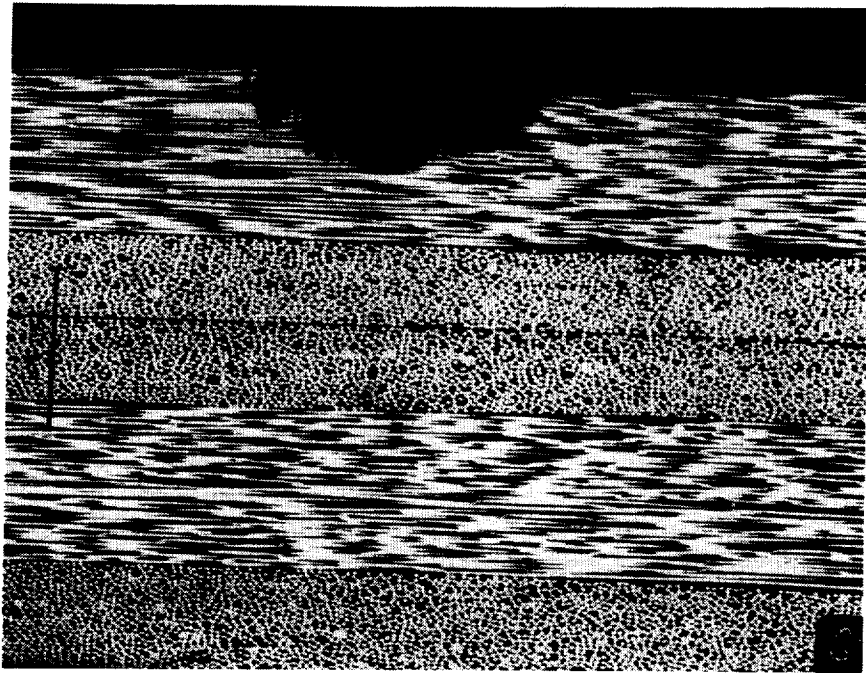

FIGURE IX - CROSS SECTIONAL PHOTOMICROGRAPH OF IMPACT #3 IN A-276
COATED T300/934

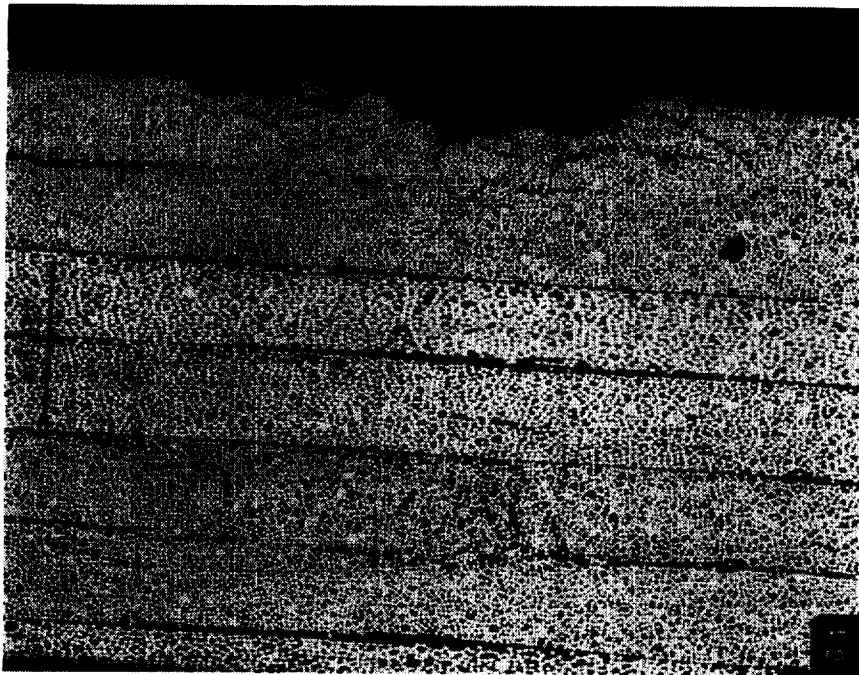

FIGURE X - CROSS SECTIONAL PHOTOMICROGRAPH OF IMPACT #4 IN A-276
COATED T300/934

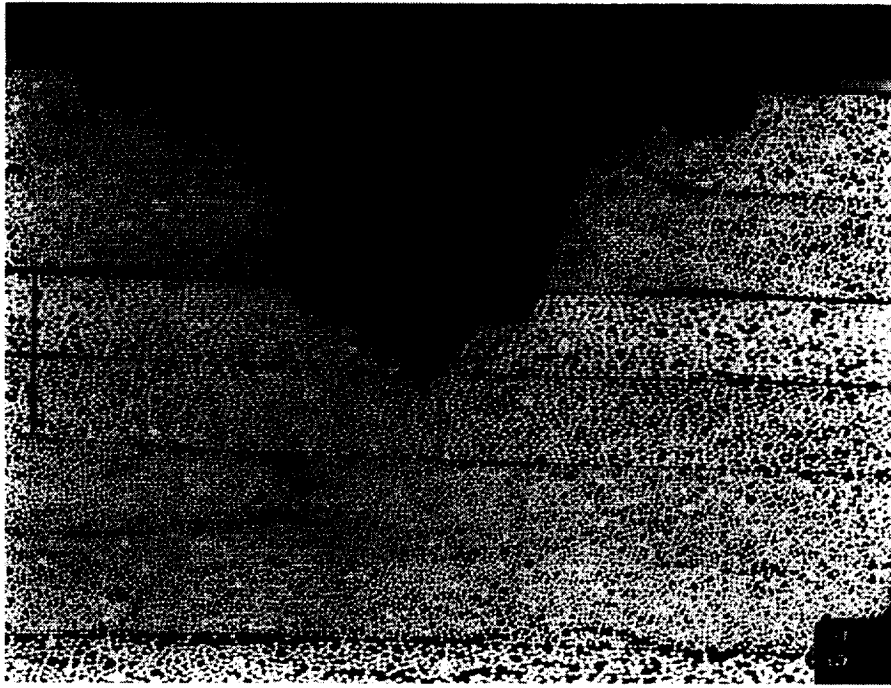

FIGURE XI - CROSS SECTIONAL PHOTOMICROGRAPH OF IMPACT #5 IN A-276 COATED T300/934

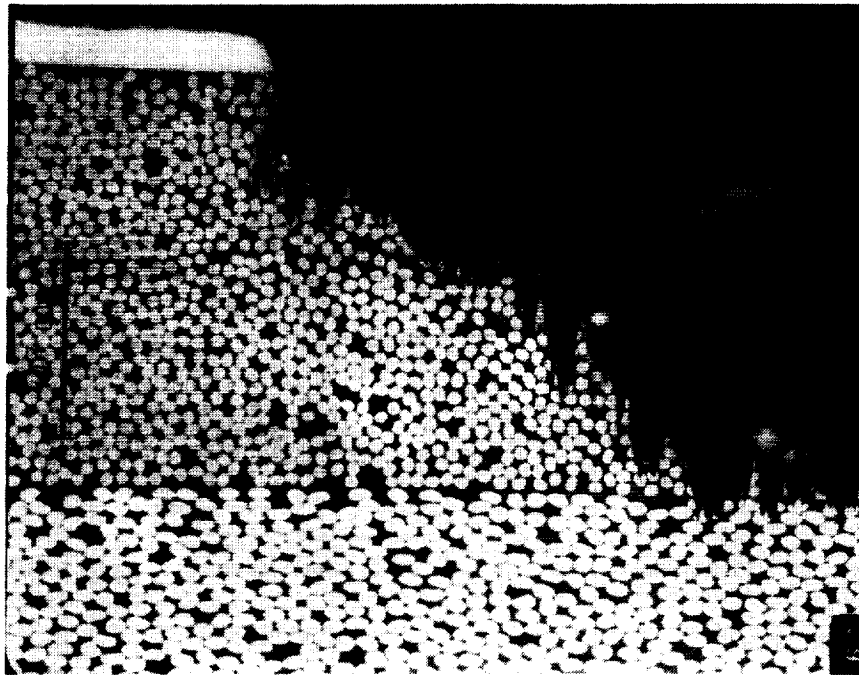

FIGURE XII - ATOMIC OXYGEN EROSION FEATURES OF IMPACT #2

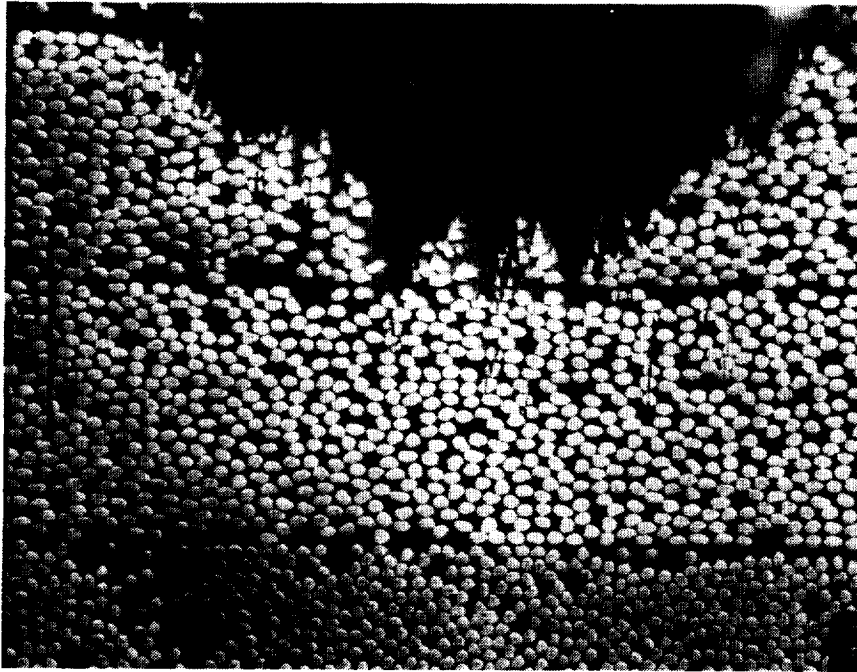

FIGURE XIII - DIFFERENTIAL INTERFERENCE CONTRAST
PHOTOMICROGRAPH OF FIBER CRACKS IN IMPACT #5

LDEF Panel & Subsurface Temperatures

White, Black, Bare (initial), & Bare (final) Panels

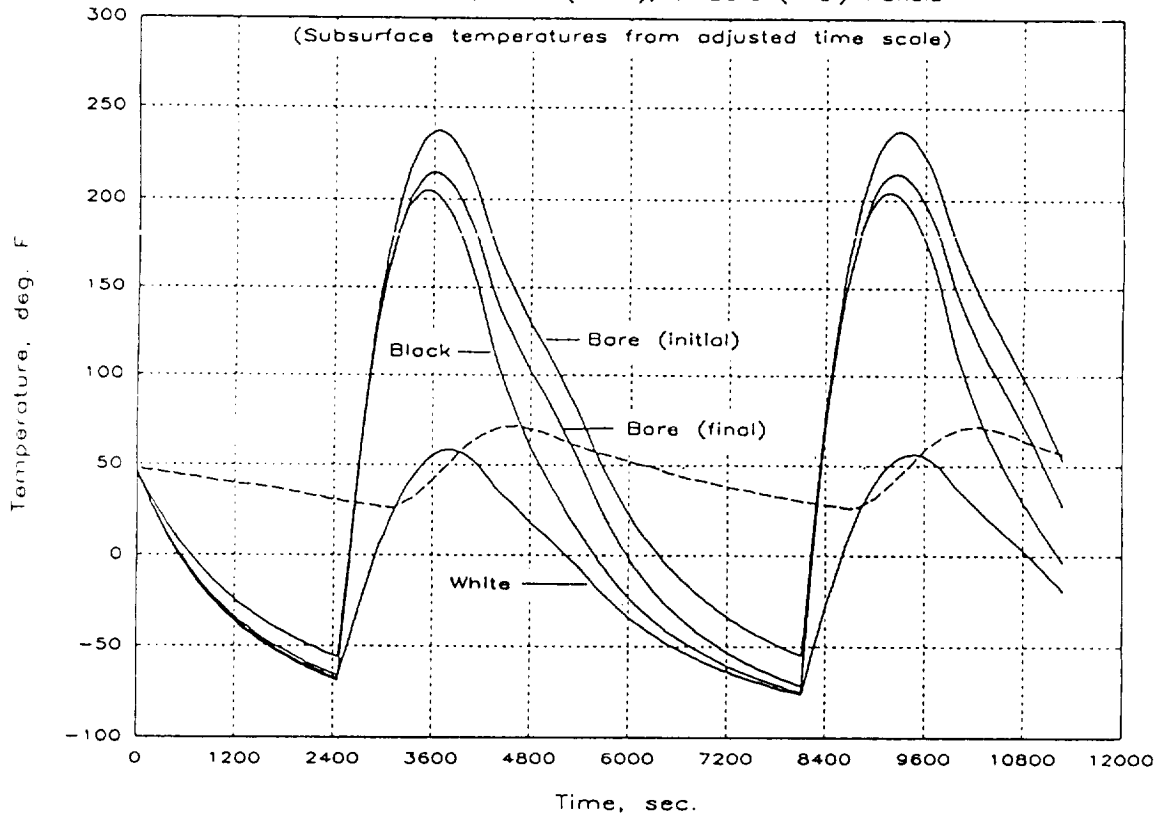

FIGURE XIV - RESULTS OF THERMAL CYCLE MODELING FOR LDEF
EXPOSURE OF T300 GRAPHITE 934 EPOXY PANEL

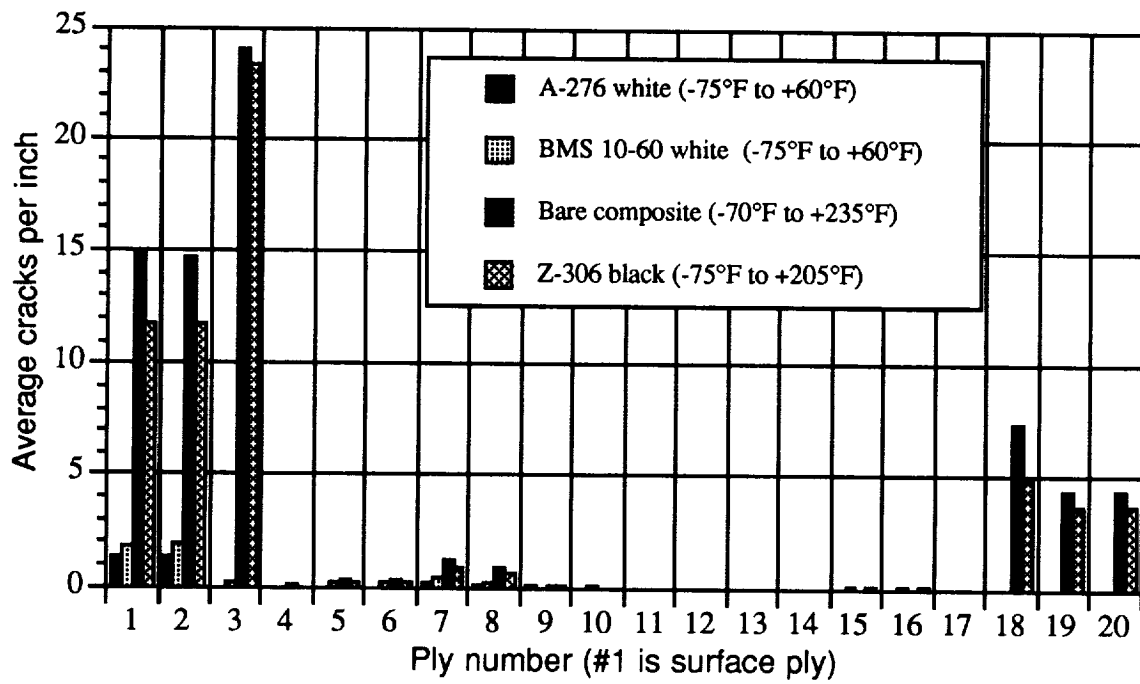

FIGURE XV - MICROCRACK DENSITY VS. PLY NUMBER FOR THE COATED AND UNCOATED COMPOSITE SUBSTRATES

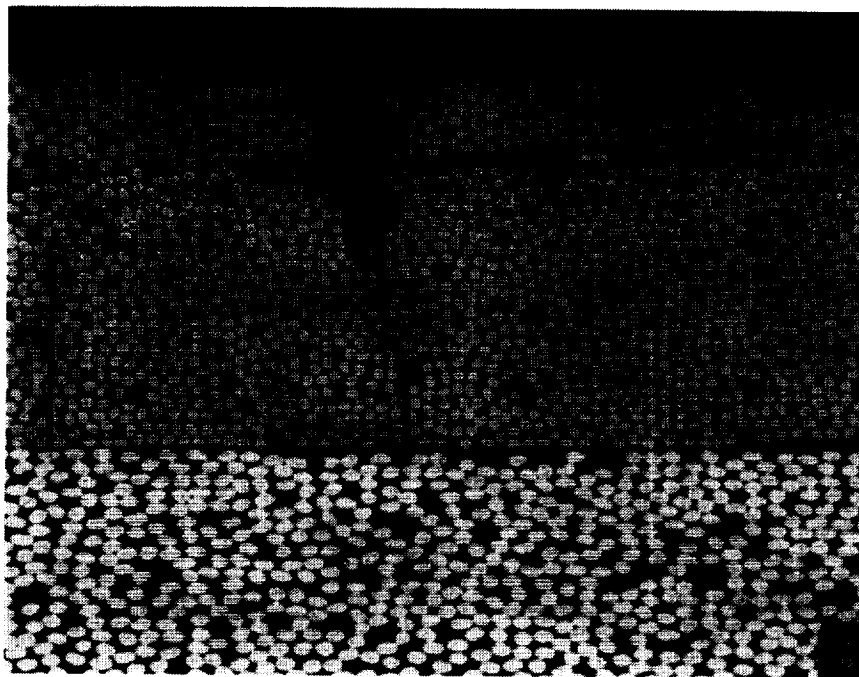

FIGURE XVI - CROSS SECTIONAL PHOTOMICROGRAPH OF MICROCRACK IN SURFACE PLY OF EXPOSED UNCOATED T300/934 PANEL QUADRANT

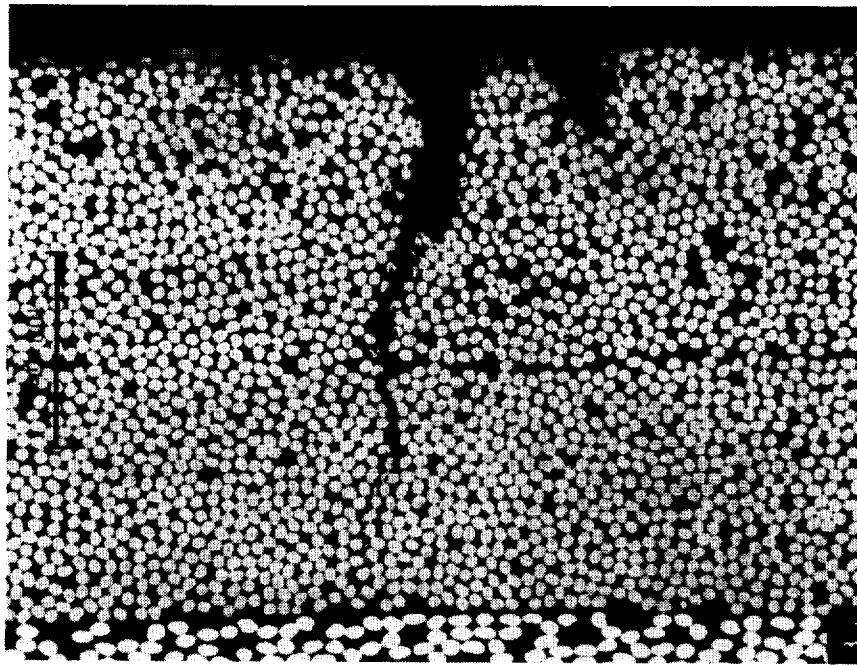

FIGURE XVII - CROSS SECTIONAL PHOTOMICROGRAPH OF MICROCRACK IN SURFACE PLY OF EXPOSED Z306 COATED T300/934 PANEL QUADRANT

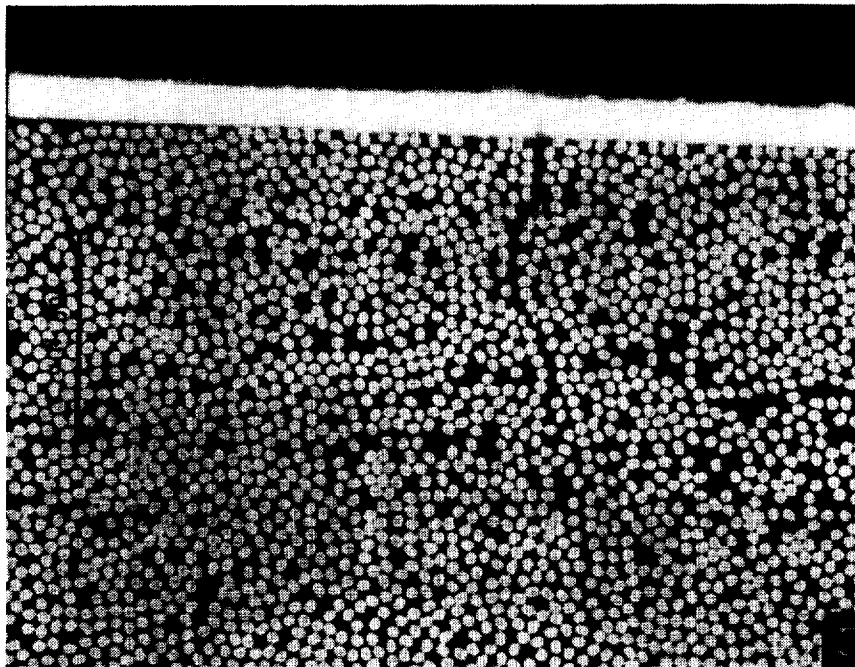

FIGURE XVIII - CROSS SECTIONAL PHOTOMICROGRAPH OF MICROCRACK IN SURFACE PLY OF EXPOSED A276 COATED T300/934 PANEL QUADRANT

