

501869

Debris/Ice/TPS Assessment and Integrated Photographic Analysis for Shuttle Mission STS-55

May 1993

(NASA-TM-107559) DEBRIS/ICE/TPS
ASSESSMENT AND INTEGRATED
PHOTOGRAPHIC ANALYSIS FOR SHUTTLE
MISSION STS-55 Final Report, 22
Mar. - 7 May 1993 (NASA) 136 p

N93-29136

Unclas

G3/16 0171937



National Aeronautics and
Space Administration

ORIGINAL DOCUMENT
COPY NUMBER 10

Debris/Ice /TPS Assessment and Integrated Photographic Analysis for Shuttle Mission STS-55

Gregory N. Katnik
NASA/Kennedy Space Center

Barry C. Bowen
NASA/Kennedy Space Center

J. Bradley Davis
NASA/Kennedy Space Center

May 1993



DEBRIS/ICE/TPS ASSESSMENT
AND
PHOTOGRAPHIC ANALYSIS
OF
SHUTTLE MISSION STS-55

April 26, 1993

Prepared By:



J. Bradley Davis
NASA/Kennedy Space Center



Barry C. Bowen
NASA/Kennedy Space Center



Jorge E. Rivera
Mechanical/Structural Sys
NASA/Kennedy Space Center

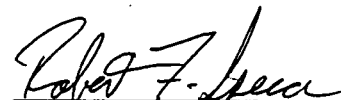

Robert F. Speece
Thermal Protection System
NASA/Kennedy Space Center

Approved:



Gregory N. Katnik
Shuttle Ice/Debris Systems
NASA/Kennedy Space Center
TV-MSD-22



Pedro J. Rosado
Chief, ET Mechanical Sys
NASA/Kennedy Space Center
TV-MSD-22

TABLE OF CONTENTS

1.0	Summary	2
2.0	Abort	5
2.1	Ice/Frost Inspection	5
2.2	Orbiter	5
2.3	Solid Rocket Boosters	5
2.4	External Tank	8
2.5	Facility	11
2.6	Post Drain Vehicle Inspection	14
3.0	Pre-Launch Briefing	17
3.1	Pre-Launch SSV/Pad Debris Inspection	18
4.0	Launch	22
4.1	Ice/Frost Inspection	22
4.2	Orbiter	22
4.3	Solid Rocket Boosters	25
4.4	External Tank	25
4.5	Facility	29
5.0	Post Launch Pad Debris Inspection	37
6.0	KSC Film Review and Problem Reports	40
6.1	Abort Film and Video Summary	40
6.2	Launch Film and Video Summary	41
6.3	On-Orbit Film and Video Summary	45
6.4	Landing Film and Video Summary	51
7.0	SRB Post Flight/Retrieval Assessment	52
7.1	RH SRB Debris Inspection	52
7.2	LH SRB Debris Inspection	61
7.3	Recovered SRB Disassembly Findings	71
8.0	Orbiter Post Landing Debris Assessment	72
9.0	Debris Sample Lab Reports	91
10.0	Post Launch Anomalies	97
10.1	Launch Pad/Facility	97
10.2	External Tank	97
10.3	Solid Rocket Boosters	97
10.4	Orbiter	98
	Appendix A. JSC Photographic Analysis Summary	99
	Appendix B. MSFC Photographic Analysis Summary	116
	Appendix C. Rockwell Photo Analysis Summary	125

FOREWORD

The Debris Team has developed and implemented measures to control damage from debris in the Shuttle operational environment and to make the control measures a part of routine launch flows. These measures include engineering surveillance during vehicle processing and closeout operations, facility and flight hardware inspections before and after launch, and photographic analysis of mission events.

Photographic analyses of mission imagery from launch, on-orbit, and landing provide significant data in verifying proper operation of systems and evaluating anomalies. In addition to the Kennedy Space Center (KSC) Photo/Video Analysis, reports from Johnson Space Center, Marshall Space Flight Center, and Rockwell International - Downey are also included in this document to provide an integrated assessment of the mission.

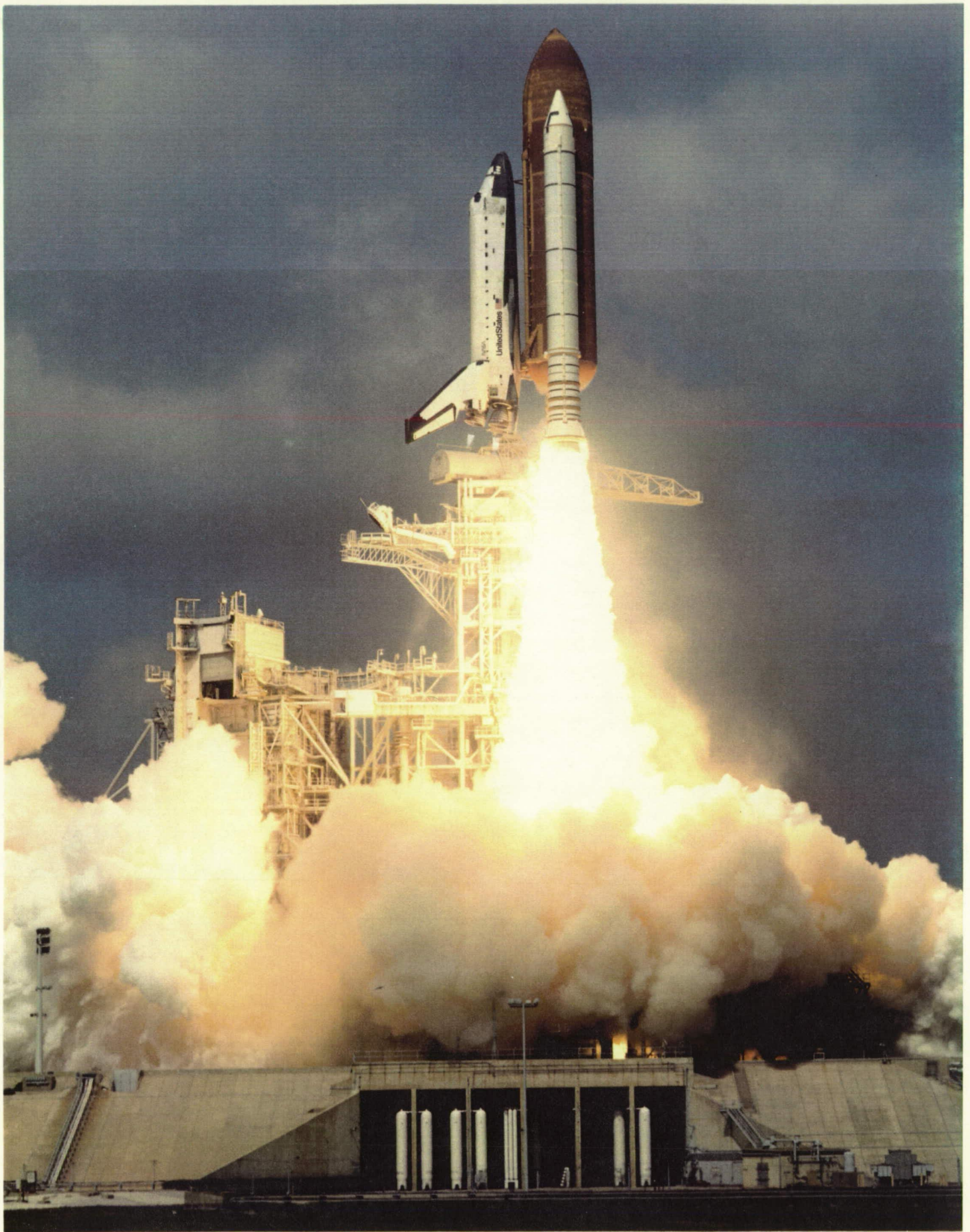

Shuttle Mission STS-55 was launched at 10:50 a.m. local 4/26/93

1.0 Summary

The Ice/Frost Inspection of the cryoloaded vehicle was performed on 22 March 1993 for the first launch attempt. There were no Launch Commit Criteria, OMRS, or NSTS-08303 violations. There were no conditions outside of the established data base. The launch of STS-55 was aborted at T-3 seconds due to a problem with the SSME #3 oxidizer preburner purge check valve.

A post drain inspection of the vehicle after the abort revealed no significant anomalies. Tiles were generally undamaged from SSME ignition and FIREX water spray with the exception of 15-20 small damage sites (1/2-inch diameter maximum) on the base heat shield and aft RCS stingers. The Orbiter SSME #2 Dome Mounted Heat Shield (DMHS) closeout blanket appeared to be scorched or discolored.

A total of 42 films and videos were reviewed after the abort. There were no significant vehicle anomalies. After SSME shut down, burning hydrogen drifted upward to the base heat shield scorching the SSME #2 DMHS panels, burning LH aft stinger RCS thruster paper covers, and burning insulation on the LH2 T-0 umbilical disconnect lines.

A pre-launch debris inspection of the pad and Shuttle vehicle was conducted on 23 April 1993. The detailed walkdown of Launch Pad 39A and MLP-3 also included the primary flight elements OV-102 Columbia (14th flight), ET-56 (LWT 49), and BI-057 SRB's. There were no vehicle anomalies. The launch, scrubbed on April 24th prior to cryoloading due to an Orbiter IMU #2 problem, was re-scheduled for 26 April 1993.

A repeat of the pre-launch debris inspection had not been planned since the MLP deck was subject to controlled access. The only work to be performed on April 25th consisted of topping off the water in the SRB sound suppression water troughs and adjusting the film in the MLP deck cameras. During these activities, 5 stainless steel 5/8-inch diameter bolts from the handrails were found under the E-17 Camera wedge mount. Additional debris inspections were performed throughout the day. Seven more pieces of hardware (3 bolts, 1 nut, and 3 welding rods) were found under the raised deck adjacent to the SSME exhaust hole.

The vehicle was cryoloaded for flight on 26 April 1993. There were no Launch Commit Criteria, OMRS, or NSTS-08303 criteria violations. There were no ice conditions outside of the established data base. The External Tank exhibited light condensate on the TPS acreage. The LH2 ET/ORB umbilical leak sensor detected no significant hydrogen leakage during the cryoload. No unusual vapors or cryogenic drips were visible during tanking, stable replenish, and launch.

A 4-inch long by 1/4-inch wide crack in the -Y vertical strut cable tray forward surface TPS near the longeron closeout interface propagated outboard. A second crack, 10 inches long, by 1/4-inch wide occurred along the bondline in the center of the cable tray closeout and propagated inboard. Continued propagation of both cracks in flight would most likely result in one long crack on the forward surface of the cable tray foam. The cracks exhibited no offset and were not filled with ice or frost. The condition was acceptable for flight per the NSTS-08303 criteria.

A debris inspection of Pad 39A was performed after launch. No flight hardware or TPS materials were found. EPON shim material on the south holddown posts was intact. There was no visual indication of a stud hang-up on any of the south holddown posts. No frangible nut/ordnance fragments were found. Damage to the facility overall was minimal.

A total of 100 films and videos were analyzed as part of the post launch data review. No major vehicle damage or lost flight hardware was observed that would have affected the mission. No stud hang-ups occurred and no ordnance debris fell from any of the HDP DCS/stud holes. All T-0 umbilicals operated properly.

An electromagnetic disturbance was detected by UHF Receiver #4 and the Lightning Detector and Ranging System (LDAR) in the vicinity of the vehicle 47-50 seconds MET. Although localized flow condensation formed on various parts of the vehicle during ascent, no sign of the electrostatic discharge event was visible on the long range trackers.

On-orbit imagery, ET/ORB umbilical cameras and the flight crew handheld photography, revealed nominal SRB and ET separations. The right bipod jack pad TPS closeout was missing. Six divots were present in the LH2 tank-to-intertank flange closeout. One divot occurred in the intertank acreage between the left bipod ramp closeout and the -Y thrust panel. At least 15-20 small "popcorn" type divots were visible on intertank stringer heads in an area just forward of the bipods. Three divots were present in the LH2 tank acreage near the LH2 tank-to-intertank flange closeout. Loss of TPS on the +Z side of the ET near the Orbiter nose is a potential threat to lower surface tiles.

Film analysis also showed orbiter flight performance, landing gear extension, wheel touchdown, drag chute deployment, and vehicle rollout were normal.

The Solid Rocket Boosters were inspected at Hanger AF after retrieval. The right frustum was missing no TPS, but had 32 MSA-2 debonds over fasteners. The LH frustum had a total of 21 MSA-2 debonds over fasteners. MSA-2 was missing from five areas and debonded in two areas on the LH aft skirt acreage TPS. Part of the HDP #3 inboard sidewall EPON shim material was missing and may have been the two pieces observed in the film review

falling from the aft skirt foot/holddown post area. An NSI detonator was wedged between the HDP #4 Debris Containment System (DCS) plunger and the stud hole wall. The HDP #5 DCS plunger was obstructed by frangible nut halves. The other DCS plungers were seated properly.

A post landing inspection of OV-102 was conducted after the landing at ADFRF/EAFB. The Orbiter TPS sustained a total of 143 hits, of which 13 had a major dimension of one inch or greater. The Orbiter lower surface had a total of 128 hits, of which 10 had a major dimension of one inch or greater. Based on these numbers and comparison to statistics from previous missions of similar configuration, the total number of Orbiter TPS debris hits was near average and the number of hits one inch or larger was less than average. Inspection of the RH ET/ORB attach point (EO-3) revealed the hole-plugger had not seated fully and was obstructed by a frangible nut half. Two ordnance fragments were found on the runway below the LO2 ET/ORB umbilical after the ET doors were opened. EO-1 and EO-2 ET/Orbiter separation devices appeared to have functioned properly.

A post landing inspection of EAFB Runway 22 was performed immediately after landing. Eleven pieces of black tile were recovered in the approximate area of the drag chute deployment. These tile fragments originated from the rudder/speed brake "stinger", which is an area damaged on previous uses of the drag chute by contact with the parachute riser lines. Aside from the damage to the vertical stabilizer stinger, the drag chute appeared to have functioned nominally. All drag chute hardware was recovered and appeared to be in good condition.

Orbiter post landing microchemical sample results revealed a variety of residuals in the Orbiter window samples from sources such as Orbiter TPS, SRB BSM exhaust residue, natural landing site products, organics, and paint. These residual sampling data do not indicate a single source of damaging debris as all of the observed materials have been documented previously in post-landing sample reports. The residual sample data also showed no debris trends when compared to previous mission data.

A total of ten Post Launch Anomalies were observed during the STS-55 mission assessment.

2.0 ABORT

A Pre-Launch inspection of Pad 39A and the flight hardware was performed on 21 March 1993 from 1000-1100 hours. Other than a piece of loose thermal curtain tape on the LH SRB aft skirt near HDP #5, no vehicle anomalies were found.

The launch of STS-55 was aborted at T-3 seconds due to a problem with the SSME #3 oxidizer preburner purge check valve.

2.1 ICE/FROST INSPECTION

The Ice/Frost Inspection of the cryoloaded vehicle was performed on 22 March 1993 from 0500 to 0710 hours during the two hour built-in-hold at T-3 hours in the countdown. There were no Launch Commit Criteria, OMRS, or NSTS-08303 violations. There were no conditions outside of the established data base. Ambient weather conditions at the time of the inspection were:

Temperature:	63.5 Degrees F
Relative Humidity:	86.5 Percent
Wind Speed:	7.2 Knots
Wind Direction:	074 Degrees

A portable Shuttle Thermal Imager (STI) infrared scanning radiometer was utilized to obtain vehicle surface temperature measurements for an overall thermal assessment of the vehicle, as shown in Figures 1 and 2.

2.2 ORBITER

No Orbiter RCC panel anomalies were observed. A coating of black paint was missing from three tiles on the RH wing leading edge extension (IPR 55V-0119). All RCS thruster paper covers and water spray boiler plugs were intact. Typical ice and frost accumulations were present at the SSME #2 heat shield-to-nozzle interfaces. The SSME #1 and #2 heat shields and the base heat shield tiles were dry. An infrared scan revealed no unusual temperature gradients on the base heat shield or engine mounted heat shields. No unusual vapors originated from inside the SSME nozzles.

2.3 SOLID ROCKET BOOSTERS

No SRB anomalies or loose ablator/cork were observed. The STI portable infrared scanner recorded RH and LH SRB case temperatures between 64 and 66 degrees Fahrenheit (F). In comparison, temperatures measured by a hand-held Minolta/Land Cyclops spot radiometer ranged from 66 to 67 degrees F and the SRB Ground Environment Instrumentation (GEI) measured temperatures of 66 degrees F. All measured temperatures were above the 34 degrees F minimum requirement. The predicted Propellant Mean Bulk Temperature (PMBT) supplied by MTI was 65 degrees F, which was within the required range of 44-86 degrees F.

Figure 1. **SSV INFRARED SCANNER
SURFACE TEMPERATURE
SUMMARY DATA**

TIME: approx. 0600 EST
 DATE: 03/22/93
 VEH. STS- 55 (Abort)

All measurements in
 degrees Fahrenheit

Target emissivity
 assumed to be 1.0

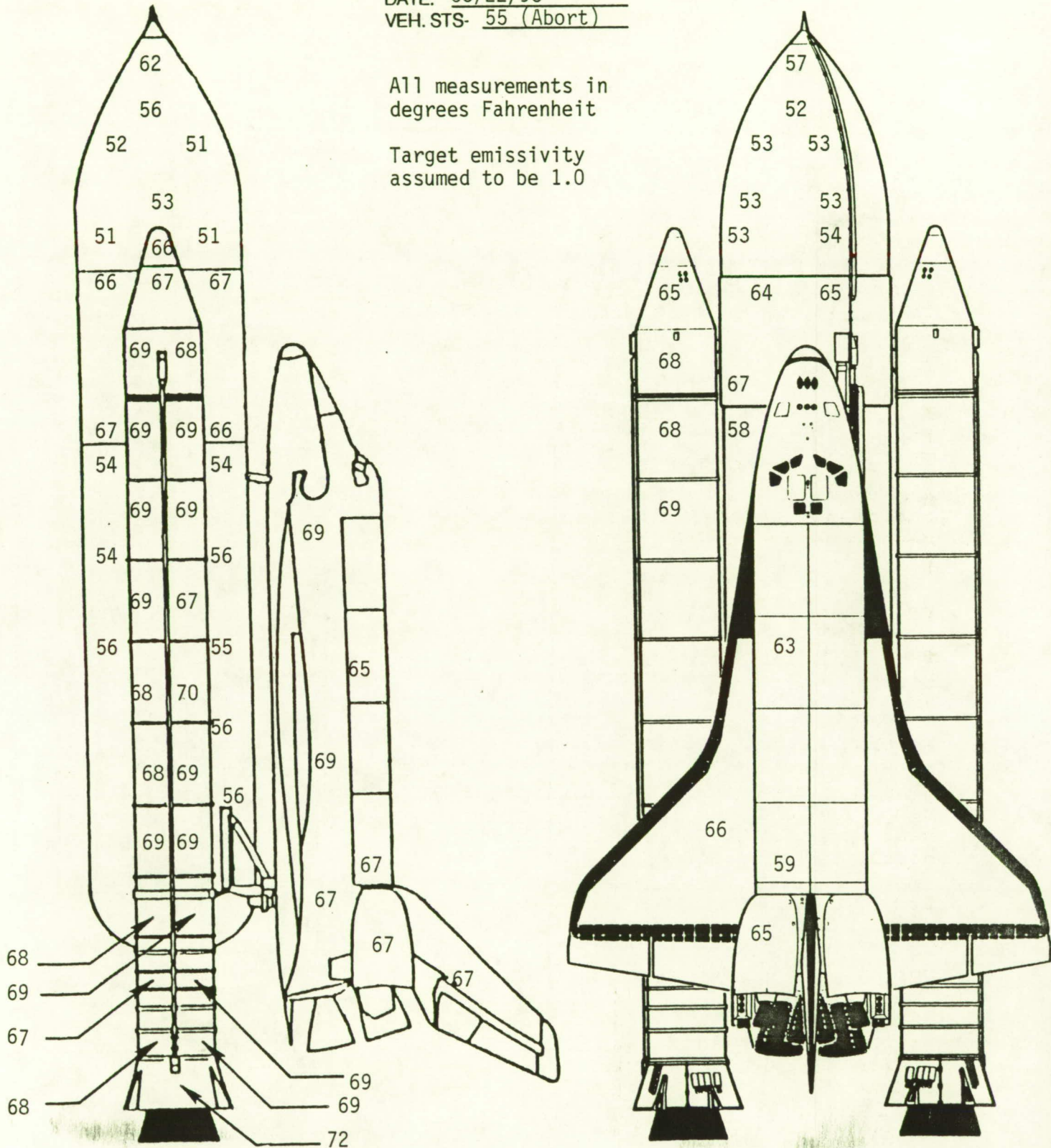
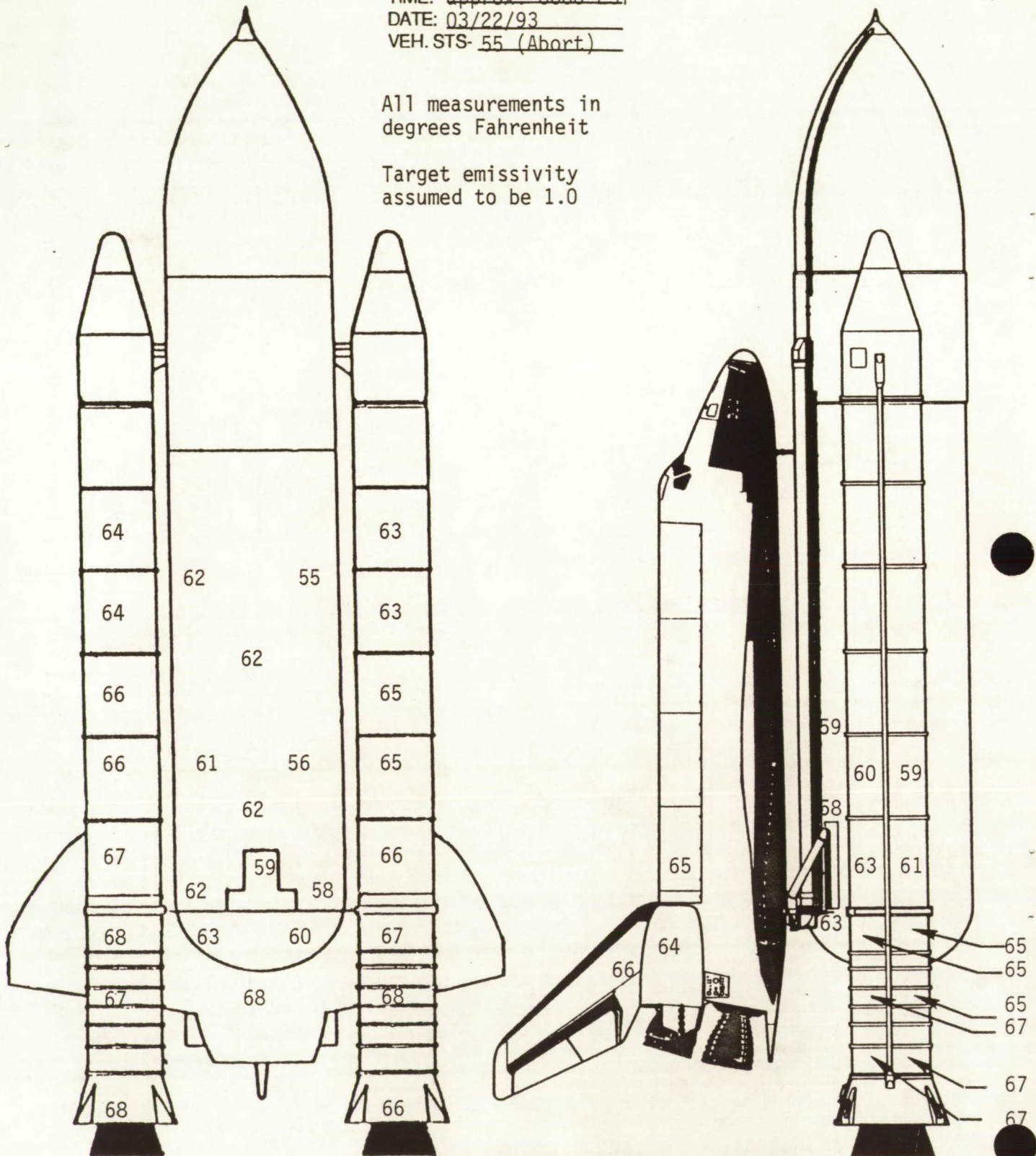

Figure 2. **SSV INFRARED SCANNER
SURFACE TEMPERATURE
SUMMARY DATA**

TIME: approx 0600 EST
 DATE: 03/22/93
 VEH. STS- 55 (Abort)

All measurements in
degrees Fahrenheit

Target emissivity
assumed to be 1.0



2.4 EXTERNAL TANK

The ice/frost prediction computer program 'SURFICE' was run from 0215 to 1015 hours and the results tabulated in Figure 3. The program predicted condensate with no ice/frost accumulation on the TPS acreage surfaces during cryoload.

There was no condensate or ice/frost accumulations on the L02 tank ogive. Some light condensate was present on the L02 tank barrel section. There were no TPS anomalies. The tumble valve cover was intact. The pressurization line and support ramps were in nominal configuration. The portable STI measured surface temperatures that averaged 56 degrees F on the ogive and 53 degrees F on the barrel section. In comparison, the Cyclops radiometer measured temperatures that averaged 54 degrees F on the ogive and 52 degrees F on the barrel; SURFICE predicted temperatures of 51 degrees F on the ogive and 48 degrees F on the barrel.

The intertank acreage TPS was dry. No frost spots appeared in the stringer valleys at the LH2 and L02 tank-to-intertank flanges. Small ice balls had formed at two places where inter-tank stringers were attached to the LH2 tank-to-intertank flange (-Z side). Typical ice/frost accumulations and no unusual vapors were present on the ET umbilical carrier plate. The portable STI measured an average surface temperature of 66 degrees F on the intertank.

There were no LH2 tank TPS acreage anomalies. Light condensate, but no ice or frost, was present on the acreage and aft dome. The portable STI measured surface temperatures that averaged 54 degrees F on the upper LH2 tank and 56 degrees F on the lower LH2 tank. In comparison, the Cyclops radiometer measured temperatures that averaged 56 degrees F on both the upper and lower LH2 tank; SURFICE predicted temperatures of 46 degrees F on the upper LH2 tank and 52 degrees F on the lower LH2 tank.

There were no anomalies on the bipod jack pad closeouts. Some ice/frost was present in the ET/SRB cable tray-to-upper strut fairing expansion joints. Ice/frost formations, 1/4-1/2 inch in size, had accumulated on the aft dome manhole cover bondlines.

A 4-inch long crack was present in the -Y vertical strut cable tray forward surface TPS near the longeron closeout interface. The 1/4-inch wide crack exhibited no offset and was not filled with ice or frost. The appearance of the crack was expected due to the elimination of the stress relief gap at the factory.

Typical amounts of ice/frost were present in the L02 feedline bellows and support brackets.

STS- 55	TEST	S0007 ABORT - LO2 Preburner Valve				DATE: 22 March 1993				T-O TIME:		NASA KSC									
		ET	SRB	MLP	PAD	LO2	DATE:		DATE:		Ice/Frost/Debris Team										
ORBITER	102	56	BI-057	3	A	LH2				FAST FILL TIME:		02:43									
		CHILLDOWN TIME: 02:05				FAST FILL TIME: 01:54				REPLENISH TIME: 02:05			04:29								
TIME (EDT)	CONDITIONS				LH2 TANK STA 370 TO 540				LH2 TANK STA 550 TO 882					LH2 TANK STA 1130 TO 1380				LH2 TANK STA 1380 TO 2058			
	TEMP	REL HUM.	DEW PT	WIND DIR	WIND VEL	WIND DEG	LOCAL VEL	SOFT TEMP	COND RATE	ICE RATE	LOCAL VEL	SOFT TEMP	COND RATE	ICE RATE	LOCAL VEL	SOFT TEMP	COND RATE	ICE RATE	LOCAL VEL	SOFT TEMP	COND RATE
F	%	F		KNTS	DEG	KNTS	TEMP	IN/HR	IN/HR	KNTS	TEMP	IN/HR	IN/HR	KNTS	TEMP	IN/HR	IN/HR	KNTS	TEMP	IN/HR	IN/HR
0215	64.20	31.0	58.34	7	73	4.13	52.36	0.0020	-0.0978	4.13	46.98	0.0034	-0.0695	3.85	45.16	0.0036	-0.0579	8.54	52.12	0.0038	-0.1591
0220	64.60	81.2	58.81	8	59	4.72	53.57	0.0020	-0.1139	4.72	48.72	0.0035	-0.0853	5.60	49.33	0.0038	-0.0994	9.68	53.41	0.0038	-0.1890
0245	65.00	82.2	59.54	9	63	5.31	54.80	0.0021	-0.1317	5.31	50.40	0.0036	-0.1027	6.30	50.99	0.0040	-0.1196	10.89	54.76	0.0039	-0.2214
0300	64.80	82.4	59.41	9	71	5.31	54.63	0.0021	-0.1305	5.31	50.21	0.0036	-0.1015	4.95	48.89	0.0039	-0.0879	10.98	54.63	0.0039	-0.2214
0315	64.40	82.8	59.15	8	87	4.72	53.68	0.0021	-0.1146	4.72	48.83	0.0036	-0.0860	4.40	47.16	0.0038	-0.0733	9.76	53.58	0.0040	-0.1912
0330	63.40	82.8	58.16	7	93	4.13	51.84	0.0021	-0.0950	4.13	46.44	0.0034	-0.0868	3.85	44.59	0.0036	-0.0553	8.54	51.63	0.0040	-0.1547
0345	63.80	83.8	58.89	8	86	4.72	53.22	0.0022	-0.1119	4.72	48.35	0.0036	-0.0833	4.40	46.67	0.0039	-0.0708	9.76	53.16	0.0041	-0.1867
0400	63.80	83.0	58.62	8	90	4.72	53.06	0.0021	-0.1109	4.72	48.18	0.0036	-0.0824	4.40	46.50	0.0038	-0.0699	9.76	52.98	0.0040	-0.1849
0415	62.20	84.2	57.43	6	80	3.54	49.86	0.0021	-0.0766	3.54	43.77	0.0031	-0.0489	3.30	41.74	0.0035	-0.0384	7.32	49.47	0.0040	-0.1211
0430	61.40	85.0	56.90	5	70	2.95	47.91	0.0021	-0.0606	2.95	41.02	0.0031	-0.0332	2.75	38.72	0.0033	-0.0236	6.10	47.24	0.0040	-0.0915
0445	61.60	86.4	57.55	5	75	2.95	48.41	0.0021	-0.0827	2.95	41.53	0.0032	-0.0352	2.75	39.24	0.0033	-0.0255	6.10	47.74	0.0041	-0.0949
0500	62.80	87.0	58.93	5	73	2.95	49.90	0.0022	-0.0691	2.95	43.07	0.0033	-0.0414	2.75	40.83	0.0036	-0.0313	6.10	49.24	0.0043	-0.1048
0515	63.00	87.8	59.38	5	54	3.54	51.45	0.0023	-0.0845	3.54	45.43	0.0038	-0.0564	4.20	46.06	0.0040	-0.0657	7.26	51.04	0.0044	-0.1328
0530	62.60	86.6	59.20	8	68	4.72	53.12	0.0023	-0.1113	4.72	48.23	0.0038	-0.0827	4.40	46.55	0.0040	-0.0701	9.76	53.09	0.0044	-0.1861
0545	63.60	87.0	59.73	7	70	4.13	52.90	0.0024	-0.1009	4.13	47.53	0.0037	-0.0724	3.85	45.69	0.0039	-0.0605	8.54	52.74	0.0044	-0.1649
0600	63.40	86.2	59.27	7	76	4.13	52.52	0.0023	-0.0987	4.13	47.14	0.0037	-0.0704	3.85	45.29	0.0039	-0.0686	8.54	52.34	0.0043	-0.1614
0615	63.40	85.2	58.95	6	88	3.54	51.40	0.0022	-0.0842	3.54	45.38	0.0035	-0.0561	3.30	43.38	0.0036	-0.0463	7.32	51.02	0.0042	-0.1333
0630	62.60	88.4	59.18	7	88	4.13	52.05	0.0024	-0.0962	4.13	46.64	0.0038	-0.0679	3.85	44.78	0.0039	-0.0562	8.54	51.92	0.0045	-0.1575
0645	63.60	87.8	59.92	8	80	4.72	53.76	0.0024	-0.1153	4.72	48.90	0.0039	-0.0865	4.40	47.22	0.0041	-0.0737	9.76	53.74	0.0045	-0.1928
0700	64.40	84.5	59.74	9	83	5.31	54.65	0.0023	-0.1306	5.31	50.23	0.0038	-0.1016	4.95	48.68	0.0040	-0.0890	10.98	54.67	0.0042	-0.2219
0715	65.20	84.8	60.80	9	97	5.31	55.56	0.0023	-0.1369	5.31	51.18	0.0038	-0.1077	4.95	49.66	0.0041	-0.0937	10.98	55.58	0.0043	-0.2325
0730	66.00	82.6	60.67	10	108	5.90	56.46	0.0021	-0.1539	5.90	52.46	0.0038	-0.1244	5.50	51.06	0.0041	-0.1095	12.20	56.52	0.0039	-0.2648
0745	66.40	82.0	60.86	10	102	5.90	56.76	0.0021	-0.1562	5.90	52.77	0.0038	-0.1267	5.50	51.39	0.0040	-0.1116	12.20	56.81	0.0039	-0.2686
0800	67.00	79.2	60.49	13	111	7.67	57.88	0.0017	-0.1990	7.67	54.66	0.0035	-0.1688	7.15	53.53	0.0039	-0.1511	15.86	58.01	0.0031	-0.3523
0815	68.00	79.2	61.48	12	112	7.08	58.62	0.0018	-0.1942	7.08	55.22	0.0036	-0.1640	6.60	54.04	0.0039	-0.1467	14.64	58.69	0.0033	-0.3407
0830	68.20	76.0	60.53	14	109	8.26	58.68	0.0013	-0.2182	8.26	55.68	0.0032	-0.1877	7.70	54.63	0.0036	-0.1690	17.08	58.78	0.0023	-0.3885
0845	68.80	77.0	61.48	13	109	7.67	59.26	0.0015	-0.2121	7.67	56.10	0.0034	-0.1816	7.15	55.00	0.0037	-0.1632	15.86	59.34	0.0027	-0.3748
0900	69.20	75.0	61.14	14	108	8.26	59.48	0.0012	-0.2263	8.26	56.51	0.0031	-0.1956	7.70	55.48	0.0035	-0.1764	17.08	59.56	0.0022	-0.4026
0915	70.00	73.4	61.33	12	109	7.08	59.37	0.0012	-0.2008	7.08	56.03	0.0031	-0.1705	6.60	54.88	0.0034	-0.1530	14.64	59.38	0.0023	-0.3512
0930	69.40	73.4	60.74	10	107	5.90	58.02	0.0014	-0.1657	5.90	54.12	0.0031	-0.1360	5.50	52.79	0.0035	-0.1207	12.20	57.95	0.0027	-0.2834
0945	70.40	73.2	61.65	9	110	5.31	58.57	0.0015	-0.1580	5.31	54.38	0.0032	-0.1284	4.95	52.96	0.0035	-0.1136	10.98	58.41	0.0029	-0.2664
1000	70.4	72.8	61.5	11	112	6.49	59.31	0.0013	-0.188	6.49	55.74	0.0031	-0.1579	6.05	54.52	0.0034	-0.1413	13.42	59.27	0.0024	-0.3254
1015	70.4	72.4	61.34	13	114	7.67	59.83	0.001	-0.2175	7.67	56.72	0.0029	-0.1969	4.16	51.19	0.0034	-0.0919	18.07	60.35	0.0015	-0.4370

AVG. 65.41 81.70 59.72 3.88 E 5.24 54.63 5.24 49.96 4.90 48.44 10.89 54.52

Period of Ice Team Inspection

FIGURE 3. "SURFACE" Computer Predictions

There were no TPS anomalies on the LO2 ET/ORB umbilical. The purge barrier (baggie) was configured properly and was holding positive purge pressure. There were no accumulations of ice/frost on the acreage areas of the umbilical. Formation of ice/frost on the separation bolt pyrotechnic canister purge vents was typical. Normal venting of nitrogen purge gas had occurred during tanking, stable replenish, and launch.

Ice/frost in the LH2 recirculation line bellows and on both burst disks was typical. The LH2 feedline bellows were filled with ice and frost, which also covered portions of the straight section between the bellows. Two small ice balls had formed on the aft side of the LH2 feedline closeout.

The usual amounts of ice/frost had accumulated on the top, aft, and outboard sides of the LH2 ET/ORB umbilical purge barrier. Typical ice/frost fingers had formed on the pyro canister and plate gap purge vents. Light ice/frost was present on the aft pyrotechnic canister closeout bondline indicating a thermal short. A typical ice/frost ring had formed on the cable tray vent hole. Ice/frost had formed on the 17-inch flapper valve actuator access port foam plug closeout forward corner as a result of a small cold purge gas leak. No unusual vapors or cryogenic drips had appeared during tanking, stable replenish, and launch.

The ET/ORB hydrogen detection sensor tygon tubing was in proper position prior to removal. The tubing was successfully removed from the vehicle without contacting Orbiter tiles.

The summary of Ice/Frost Team observations/anomalies consisted of four OTV recorded items:

Anomaly 001 documented a 4-inch crack in the -Y vertical strut cable tray forward surface near the longeron closeout interface. The 1/4-inch wide crack exhibited no offset and was not filled with ice or frost. The condition was acceptable for launch per NSTS-08303 criteria and CR S041254C.

Anomaly 002 (documentation only) recorded ice/frost formations in the LH2 feedline bellows, recirculation line bellows and burst discs, and on the LH2 ET/ORB umbilical purge vents. The formations were acceptable per the NSTS-08303 criteria.

Anomaly 003 (documentation only) recorded ice/frost formations in the LO2 feedline bellows and support brackets. The ice/frost formations were acceptable per NSTS-08303 criteria.

Anomaly 004 documented ice/frost accumulation at the TPS repair bondline of the aft dome +Z manhole cover. The condition was acceptable per the NSTS-08303 criteria.

2.5 FACILITY

All SRB sound suppression water troughs were filled and properly configured for launch. There was no debris on the MLP deck or in the SRB holddown post areas.

No leaks were observed on either the LO2 or LH2 Orbiter T-0 umbilicals. Typical accumulations of ice/frost were present on the cryogenic lines and purge shrouds.

There was no apparent hydrogen leakage anywhere on the GH2 vent line or GUCP. Some ice and frost, which was expected, had accumulated on the GUCP legs and on the uninsulated parts of the umbilical carrier plate.

Visual and infrared observations of the GOX seals confirmed no leakage. No ET nosecone/footprint damage was visible after the GOX vent hood was retracted. Small icicles less than 1/2 inch in length had formed on the north GOX vent duct, but had melted prior to the time of launch.



A coating of black paint was missing from three tiles
on the right wing leading edge extension

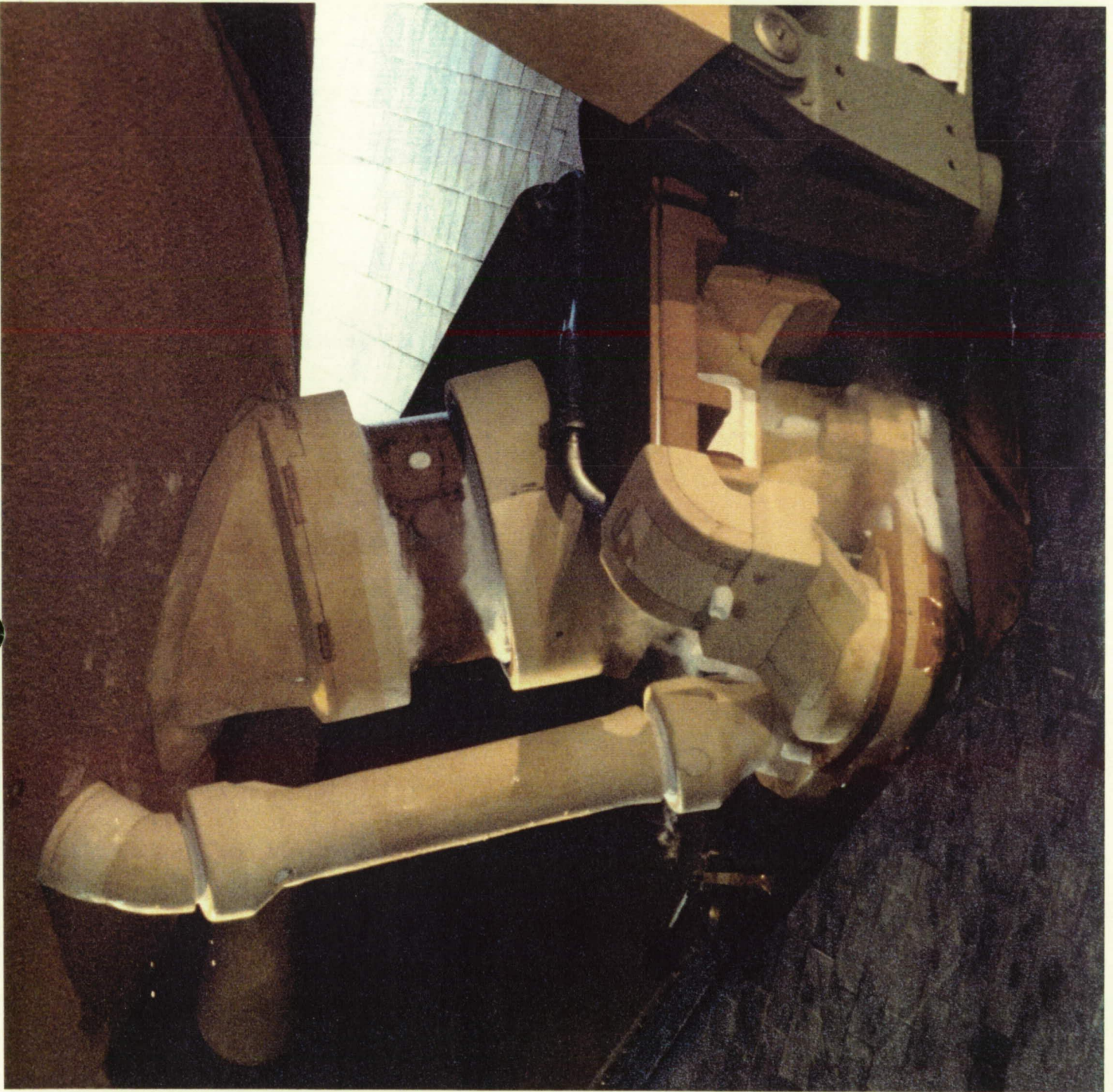

Typical amounts of ice and frost had formed on the ET/ORB LH2 umbilical, purge vents, cable tray vent hole, and recirculation line bellows. Ice/frost on the LH2 feedline bellows began to encroach on the straight (spool) section. No unusual vapors or cryogenic drips had appeared during tanking, stable replenish, and launch.

2.6 POST DRAIN VEHICLE INSPECTION

A post drain inspection of the vehicle was performed at Pad-39A from 1530 to 1715 hours on 22 March 1993.

The Orbiter SSME #2 Dome Mounted Heat Shield (DMHS) closeout blanket appeared to be scorched (discolored).

Tiles were generally undamaged from SSME ignition and FIREX water spray with the exception of 15-20 small damage sites (1/2-inch diameter maximum) on the base heat shield and aft RCS stingers. Most of the paper covers on the aft RCS thruster nozzles were torn.

There was no visible damage on the External Tank nosecone, fairing, or foot print area. No topcoat was missing. The tumble valve cover was intact.

No anomalies (divots or cracks) were observed on the LO2 tank, intertank, or LH2 tank acreage.

Ice remained in the LO2 feedline support brackets, but no loose foam or TPS damage was visible. Ice in the feedline bellows had melted.

Bipod jack pad closeouts were intact and flush with adjacent LH2 tank-to-intertank flange closeout foam.

The 4-inch crack in the -Y ET/SRB vertical strut cable tray forward surface TPS (reported during the Ice Inspection) was still visible.

Vapor was emanating from an ice/frost spot on the aft dome -Z manhole cover closeout and from a location on the aft dome apex between the two manhole covers.

No anomalies were observed on the Solid Rocket Boosters (SRB) or on the MLP deck/facility.

No significant vehicle damage was observed during the preliminary external post drain inspection. No IPR's were generated as a result of this inspection.

A subsequent hands-on inspection of the LO2 feedline revealed two anomalies. A Problem Report was taken against damaged foam on the feedline adjacent to the station XT-1129 bracket. The area was repaired with PDL. The second anomaly involved crushed foam on the intertank splice forward of the feedline bracket, station XT-1129. This condition was accepted for flight by MRB approval due to inaccessibility.



The Orbiter SSME #2 Dome Mounted Heat Shield (DMHS) closeout blanket appeared to be scorched and discolored

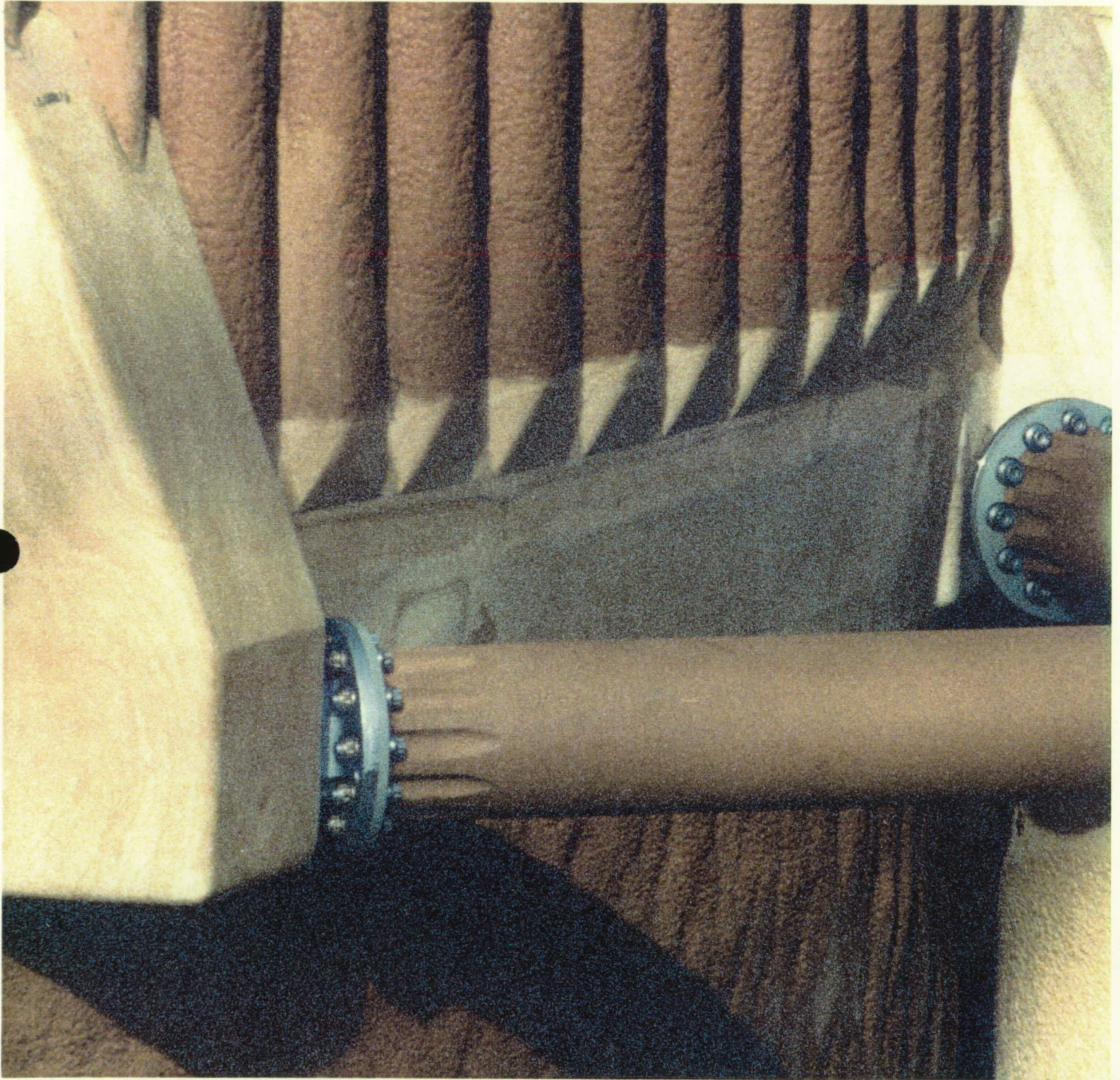

Bipod jack pad closeouts were intact and flush with adjacent LH2 tank-to-intertank flange closeout foam

3.0 PRE-LAUNCH BRIEFING

The Ice/Debris/TPS/Photographic Analysis Team briefing for launch activities was conducted on 23 April 1993 at 0930 hours with the following key personnel present:

B. Davis	NASA - KSC	STI, Ice/Debris Assessment
G. Katnik	NASA - KSC	Lead, Ice/Debris/Photo Team
B. Speece	NASA - KSC	Lead, ET Thermal Protection
B. Bowen	NASA - KSC	ET Processing, Ice/Debris
K. Tenbusch	NASA - KSC	ET Processing, Ice/Debris
P. Rosado	NASA - KSC	Chief, ET Mechanical Systems
J. Rivera	NASA - KSC	Lead, ET Structures
A. Oliu	NASA - KSC	ET Processing, Ice/Debris
J. Cawby	LSOC - SPC	Supervisor, ET Processing
M. Jaime	LSOC - SPC	ET Processing
M. Dean	LSOC - SPC	ET Processing
J. Blue	LSOC - SPC	ET Processing
Z. Byrns	NASA - JSC	Level II Integration
J. McClymonds	RI - DNY	Debris Assess, LVL II Integ
K. Mayer	RI - LSS	Vehicle Integration
R. Hillard	MTI - LSS	SRM Processing
S. Otto	MMMSS- LSS	ET Processing

These personnel participated in various team activities, assisted in the collection and evaluation of data, and contributed to reports contained in this document.

3.1 PRE-LAUNCH SSV/PAD DEBRIS INSPECTION

A pre-launch debris inspection of the pad and Shuttle vehicle was conducted on 23 April 1993 from 1030 - 1130 hours. The detailed walkdown of Launch Pad 39A and MLP-3 also included the primary flight elements OV-102 Columbia (14th flight), ET-56 (LWT 49), and BI-057 SRB's. Documentary photographs were taken of facility anomalies, potential sources of vehicle damaging debris, and vehicle configuration changes.

There were no significant vehicle anomalies or debris issues.

A metal part tag, 2.5" x 0.625" in size and stamped with the numbers "79K 80240-13", lay against Orbiter tile on top of the Orbiter Access Arm (OAA) inflated seal. The tag was removed by pad operations personnel inside the white room by moving the inflated seal. No damage to Orbiter tiles was detected.

A small cotter pin in the LH2 TSM south ladder upper hand ring support was replaced real-time by pad technicians with a large pull ring. The replacement matched the ring in the lower support.

Six pieces of K5NA in the HDP #5 haunch area and two objects (the largest measuring 3"x0.75"x0.5") in the HDP #1 haunch area were removed real-time by pad technicians. The MLP deck and areas under the raised deck were swept/vacuumed again prior to launch to remove small debris items, such as sand, rust flakes, and paint chips. No items were entered in S0007, Appendix K.

The launch, scrubbed on April 24th prior to cryoloading due to an Orbiter IMU #2 problem, was re-scheduled for 26 April 1993.

A repeat of the pre-launch debris inspection had not been planned since the MLP deck was subject to controlled access. The only work to be performed on 25 April 1993 consisted of topping off the water in the SRB sound suppression water troughs and adjusting the film in the MLP deck cameras. During these activities, 5 stainless steel 5/8-inch diameter bolts from the handrails were found under the E-17 Camera wedge mount

Additional debris inspections were performed throughout the day. The following items were found under the raised deck radiation shield attach plates along side the sound suppression water nozzles and within 6 inches of the edge of the SSME exhaust hole north side:

1. 5" long by 0.75" diameter bolt
2. 4" long by 0.75" diameter bolt
3. 1.75" long by 0.438" diameter bolt (stainless)
4. 1.25" diameter nut
5. 14-inch welding rod
6. 12-inch welding rod
7. 9-inch welding rod

A series of meetings were held to discuss these recent debris issues and the following points were addressed:

1. Flushing debris out from areas underneath the raised deck by the use of water hoses is not completely effective. Pad workers should conduct a more detailed inspection using flashlights and remove any remaining debris by hand.

2. Small objects, such as bolts, washers, nuts, and other fasteners, are more difficult to control and account for when lying loose on the MLP deck. Small objects should never be loose on the deck. Fasteners should be in a container when not being installed or removed from camera housing covers, handrail supports, etc.

3. Pad workers place small objects in MLP deck cavities, under sound suppression water pipes, and on water pipe I-beam supports. The apparent reason for this practice is to keep objects out of the traffic paths. However, this can also lead to more incidents of forgotten or misplaced hardware. Pad workers should avoid using MLP cavities and I-beam "shelves" as temporary storage places.

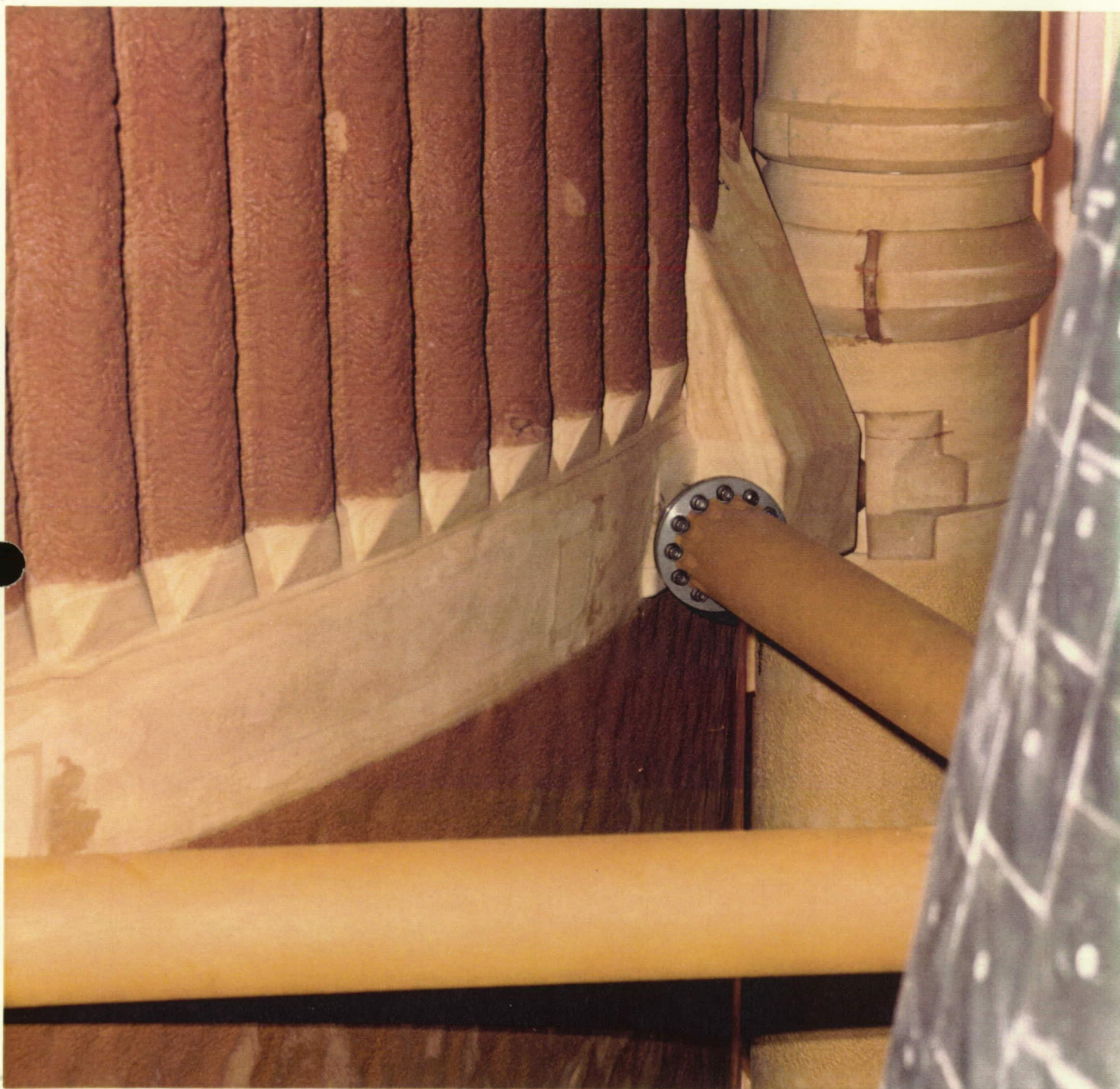

Pre-launch configuration of the bipod jack pad closeouts
after one cryogenic loading



Pre-launch view of the left (-Y) vertical strut cable tray TPS after one cryogenic loading. Cracks in the foam typically occur in this area due to the elimination of the stress relief cut.

4.0 LAUNCH

STS-55 was launched at 14:50:00.017 GMT (10:50 a.m. local) on 26 April 1993.

4.1 ICE/FROST INSPECTION

The Ice/Frost Inspection of the cryoloaded vehicle was performed on 26 April 1993 from 0530 to 0715 hours during the two hour built-in-hold at T-3 hours in the countdown. There were no Launch Commit Criteria, OMRS, or NSTS-08303 criteria violations. There were no conditions outside of the established data base. Ambient weather conditions at the time of the inspection were:

Temperature:	68.0 Degrees F
Relative Humidity:	92.6 Percent
Wind Speed:	4.1 Knots
Wind Direction:	196 Degrees

A portable Shuttle Thermal Imager (STI) infrared scanning radiometer was utilized to obtain vehicle surface temperature measurements for an overall thermal assessment of the vehicle, as shown in Figures 4 and 5.

4.2 ORBITER

No Orbiter tile or RCC panel anomalies were observed. All RCS thruster paper covers and water spray boiler plugs were intact. The loss of small areas of black paint from three tiles on the RH wing leading edge extension upper surface was no constraint for flight. Four light, almost white, colored areas on Orbiter nose lower surface tiles below the RH FRCS were found to be repaired areas.

Typical ice/frost accumulations were present at the SSME #1 and #2 heat shield-to-nozzle interfaces. Condensate was present on the SSME engine mounted heat shields, but the base heat shield tiles were dry. An infrared scan revealed no unusual temperature gradients on the base heat shield or engine mounted heat shields.

A cold spot on the inside wall of the SSME #1 nozzle was attributed to thin insulation and the attach point of the exterior LO2 drain line. The presence of the cold spot was not an anomaly. No unusual vapors originated from inside the SSME nozzles.

FIGURE 4. **SSV INFRARED SCANNER
SURFACE TEMPERATURE
SUMMARY DATA**

TIME: approx. 0600 EDT
 DATE: 04/26/93
 VEH. STS- 55

All measurements in
degrees Fahrenheit

Target emissivity
assumed to be 1.0

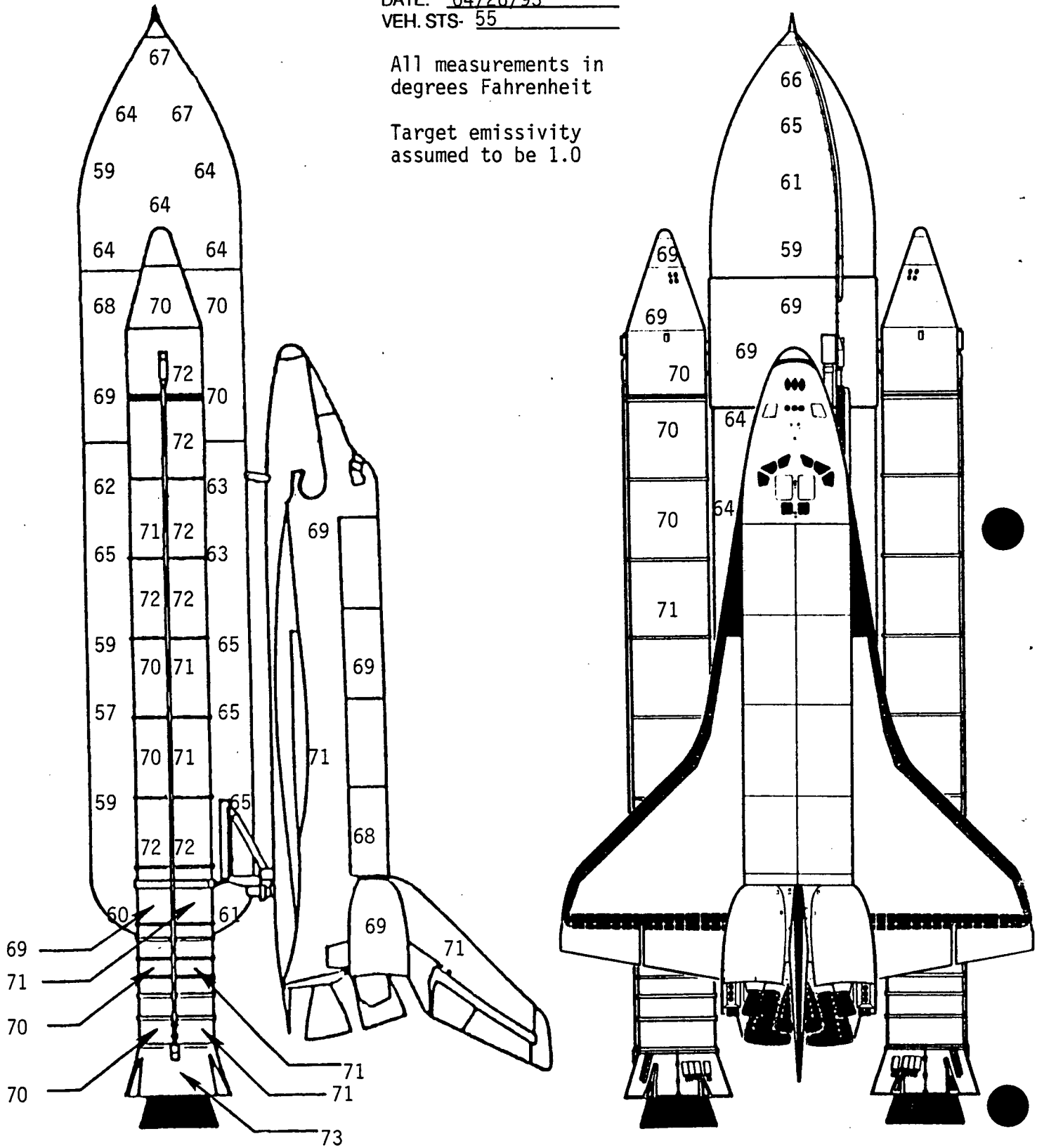

4.3 SOLID ROCKET BOOSTERS

No SRB anomalies or loose ablator/cork were observed. The K5NA closeouts of the aft booster stiffener ring splice plates were intact. The STI portable infrared scanner measured RH and LH SRB case temperatures between 68 and 72 degrees Fahrenheit (F). In comparison, temperatures measured by a hand-held Minolta/Land Cyclops spot radiometer ranged from 68 to 72 degrees F and the SRB Ground Environment Instrumentation (GEI) measured temperatures ranging from 69 to 74 degrees F. All measured temperatures were above the 34 degrees F minimum requirement. The predicted Propellant Mean Bulk Temperature (PMBT) supplied by MTI was 67 degrees F, which was within the required range of 44-86 degrees F.

4.4 EXTERNAL TANK

The ice/frost prediction computer program 'SURFICE' was run from 0230 to 1045 hours and the results tabulated in Figure 6. The program predicted condensate with no ice/frost accumulation on the TPS acreage surfaces during cryoload.

There was no condensate or ice/frost accumulations on the L02 tank ogive. Some light condensate was present on the L02 tank barrel section. There were no TPS anomalies. The tumble valve cover was intact. The pressurization line and support ramps were in nominal configuration. The portable STI measured surface temperatures that averaged 66 degrees F on the ogive and 64 degrees F on the barrel section. In comparison, the Cyclops radiometer measured temperatures that averaged 67 degrees F on the ogive and 64 degrees F on the barrel; SURFICE predicted temperatures of 58 degrees F on the ogive and 51 degrees F on the barrel.

The intertank acreage TPS was dry. Two ice/frost spots appeared on stringers at the LH2 tank-to-intertank flange closeout. Typical ice/frost accumulations and no unusual vapors were present on the ET umbilical carrier plate. The portable STI measured an average surface temperature of 71 degrees F on the intertank compared to 69 degrees as measured by the Cyclops radiometer.

There were no LH2 tank TPS acreage anomalies. Light condensate, but no ice or frost, was present on the acreage and aft dome. The portable STI measured surface temperatures that averaged 62 degrees F on the upper LH2 tank and 63 degrees F on the lower LH2 tank. In comparison, the Cyclops radiometer measured temperatures that averaged 61 degrees F on both the upper and lower LH2 tank; SURFICE predicted temperatures of 46 degrees F on the upper LH2 tank and 43 degrees F on the lower LH2 tank.

STS	TEST S0007 LAUNCH				DATE: 24 April 1993		T-0 TIME: 10:50:00.017		NASA															
	ORBITER	ET	SRB	M/LP	PAD	LO2	CHILLDOWN TIME:	FAST FILL TIME:	CHILLDOWN TIME:	FAST FILL TIME:	KSC	Ice/Frost/Dabris	Team											
102	56	BI-057	3	A			02:28	03:04	03:16	05:18	02:26	03:13	05:00											
TIME (EDT)	CONDITIONS																							
	TEMP F	REL HUM %	DEW PT F	WIND DIR	WIND DEG	LOCAL VEL KNTS	SOF TEMP	COND RATE IN/HR	ICE RATE IN/HR	REG	LOCAL VEL KNTS	SOF TEMP	COND RATE IN/HR	ICE RATE IN/HR	REG	LOCAL VEL KNTS	SOF TEMP	COND RATE IN/HR	ICE RATE IN/HR					
0230	69.40	91.4	66.87	6	159	3.54	59.44	0.0028	-0.1267		3.54	53.88	0.0044	-0.0871		2.52	48.92	0.0042	-0.0601		2.28	47.89	0.0040	-0.0526
0245	69.00	90.2	66.10	5	160	2.95	57.65	0.0026	-0.1047		2.95	51.28	0.0040	-0.0758		2.10	45.89	0.0038	-0.0443		1.90	44.60	0.0036	-0.0432
0300	69.40	89.0	66.12	7	164	4.13	58.78	0.0027	-0.1416		4.13	54.80	0.0043	-0.1119		2.94	50.18	0.0042	-0.0708		2.66	49.05	0.0041	-0.0623
0315	69.80	89.0	66.52	5	170	2.95	58.33	0.0026	-0.1080		2.95	52.01	0.0040	-0.0790		2.10	46.66	0.0038	-0.0469		1.90	45.39	0.0036	-0.0464
0330	69.80	89.2	66.38	6	176	3.54	58.21	0.0027	-0.1253		3.54	53.64	0.0042	-0.0959		2.52	48.70	0.0041	-0.0592		2.28	47.48	0.0039	-0.0518
0345	69.80	90.0	66.83	7	176	4.13	60.44	0.0028	-0.1458		4.13	55.49	0.0045	-0.1158		2.94	50.89	0.0043	-0.0739		2.66	49.76	0.0042	-0.0553
0400	69.20	91.0	66.55	6	177	3.54	58.13	0.0028	-0.1240		3.54	53.55	0.0043	-0.0955		2.52	48.57	0.0041	-0.0588		2.28	47.35	0.0040	-0.0513
0415	69.80	91.4	66.27	6	173	3.54	58.76	0.0028	-0.1228		3.54	53.15	0.0043	-0.0934		2.52	48.15	0.0041	-0.0571		2.28	46.92	0.0040	-0.0498
0430	69.60	92.4	67.37	8	182	4.72	61.40	0.0030	-0.1659		4.72	56.94	0.0048	-0.1355		3.36	52.65	0.0047	-0.0882		3.04	51.55	0.0045	-0.0793
0445	69.80	90.6	67.02	7	160	4.13	60.57	0.0029	-0.1466		4.13	55.62	0.0045	-0.1167		2.94	51.02	0.0044	-0.0745		2.66	49.87	0.0042	-0.0558
0500	69.6	90.8	66.98	6	160	3.54	59.55	0.0028	-0.1272		3.54	53.99	0.0043	-0.0977		2.52	49.03	0.0042	-0.0606		2.28	47.81	0.004	-0.0531
0515	69.60	91.0	66.94	7	166	4.13	60.43	0.0029	-0.1457		4.13	55.47	0.0045	-0.1158		2.94	50.86	0.0044	-0.0738		2.66	49.71	0.0042	-0.0551
0530	69.20	90.2	66.90	5	178	2.95	57.89	0.0026	-0.1059		2.95	51.53	0.0040	-0.0760		2.10	46.14	0.0038	-0.0451		1.90	44.86	0.0037	-0.0442
0545	69.90	90.0	66.94	5	186	2.95	57.81	0.0026	-0.1045		2.95	51.24	0.0040	-0.0753		2.10	45.84	0.0038	-0.0441		1.90	44.55	0.0036	-0.0430
0600	68.60	92.0	66.25	5	184	2.95	57.56	0.0027	-0.1043		2.95	51.17	0.0041	-0.0753		2.10	45.74	0.0039	-0.0438		1.90	44.45	0.0037	-0.0424
0615	69.20	92.0	65.86	4	192	2.96	55.94	0.0026	-0.0840		2.96	48.22	0.0038	-0.0556		1.88	43.03	0.0038	-0.0404		1.52	43.03	0.0036	-0.0404
0630	67.80	94.4	66.16	3	205	1.77	53.57	0.0024	-0.0704		1.77	44.80	0.0034	-0.0457		0.96	42.92	0.0036	-0.0400		4.08	52.91	0.0049	-0.1006
0645	67.20	93.6	65.34	4	201	2.36	54.77	0.0026	-0.0905		2.36	47.29	0.0038	-0.0521		1.88	42.04	0.0035	-0.0365		1.52	42.03	0.0035	-0.0365
0706	67.20	93.3	65.40	4	212	2.36	54.81	0.0026	-0.0896		2.36	47.33	0.0039	-0.0522		1.88	42.07	0.0036	-0.0366		1.52	42.07	0.0035	-0.0367
0715	67.00	94.6	65.44	3	210	1.77	52.64	0.0024	-0.0665		1.77	43.61	0.0034	-0.0419		0.96	41.94	0.0036	-0.0362		4.08	51.98	0.0048	-0.0955
0730	67.40	94.6	65.84	3	229	1.77	53.12	0.0024	-0.0685		1.77	44.32	0.0034	-0.0439		0.96	42.45	0.0036	-0.0382		4.08	52.46	0.0049	-0.0981
0745	67.80	94.8	66.30	3	229	1.77	53.64	0.0024	-0.0707		1.77	44.88	0.0034	-0.0460		0.96	42.98	0.0036	-0.0403		4.08	52.99	0.0049	-0.1010
0800	69.00	94.6	67.44	3	228	1.77	55.06	0.0025	-0.0768		1.77	46.39	0.0035	-0.0521		0.96	44.46	0.0037	-0.0463		4.08	54.41	0.0050	-0.1090
0815	68.80	92.0	66.45	4	242	2.36	56.34	0.0026	-0.0870		2.36	48.97	0.0038	-0.0584		1.28	43.78	0.0036	-0.0434		5.44	56.26	0.0051	-0.1441
0830	69.80	90.2	66.09	4	199	2.36	57.16	0.0025	-0.0904		2.36	48.85	0.0038	-0.0617		1.68	44.73	0.0036	-0.0473		1.52	44.73	0.0036	-0.0473
0845	70.20	88.0	66.60	4	197	2.36	57.17	0.0024	-0.0904		2.36	49.90	0.0037	-0.0618		1.68	44.85	0.0035	-0.0477		1.52	44.85	0.0035	-0.0477
0900	70.20	85.8	65.89	4	179	2.36	56.71	0.0023	-0.0885		2.36	48.42	0.0036	-0.0600		1.68	44.47	0.0034	-0.0460		1.52	44.47	0.0034	-0.0460
0915	72.20	80.6	66.11	5	181	2.95	59.24	0.0022	-0.1124		2.95	53.02	0.0036	-0.0834		2.10	47.86	0.0035	-0.0522		1.90	46.64	0.0034	-0.0522
0930	71.60	79.2	65.03	9	166	5.31	61.24	0.0020	-0.1780		5.31	57.16	0.0038	-0.1477		3.78	53.29	0.0040	-0.0977		3.42	52.28	0.0039	-0.0871
0945	71.60	78.0	64.80	8	166	4.72	60.43	0.0020	-0.1587		4.72	55.96	0.0037	-0.1288		3.36	51.81	0.0039	-0.0839		3.04	50.78	0.0037	-0.0745
1000	72.00	77.4	64.78	9	166	5.31	61.24	0.0019	-0.1780		5.31	57.18	0.0037	-0.1477		3.78	53.32	0.0039	-0.0979		3.42	52.33	0.0038	-0.0873
1015	72.40	76.6	64.89	12	174	7.08	62.60	0.0016	-0.2313		7.08	59.40	0.0036	-0.2001		5.04	56.21	0.0040	-0.1362		4.56	55.34	0.0039	-0.1222
1030	73.00	73.6	64.36	10	173	5.90	61.83	0.0015	-0.1962		5.90	58.11	0.0033	-0.1657		4.20	54.55	0.0037	-0.1113		3.80	53.62	0.0036	-0.0986
1045	73.40	71.0	63.75	12	172	7.08	62.28	0.0010	-0.2279		7.08	59.07	0.0030	-0.1969		5.04	55.92	0.0035	-0.1341		4.56	55.08	0.0035	-0.1204
T-0	73.00	69.2	62.64	11	165	6.49	61.11	0.0009	-0.2035		6.49	57.69	0.0028	-0.1730		4.62	54.28	0.0033	-0.1165		4.18	53.39	0.0033	-0.1043

AVG. 69.72 87.78 65.95 5.00 S 3.54 58.24 3.54 52.18 2.45 47.89 2.92 49.30

FIGURE 6. "SURFICE" Computer Predictions

Period of Ice Team Inspection

There were no anomalies on the bipod jack pad closeouts. Five pressurization line support ice/frost ramps exhibited small ice/frost accumulations along the aft edge bondlines. Some ice/frost was present in the ET/SRB cable tray-to-upper strut fairing expansion joints. A small crack in the TPS with associated ice/frost formation was present at both the +Y and -Y vertical strut-to-LH2 tank interface aft edges.

A 4-inch long by 1/4-inch wide crack in the -Y vertical strut cable tray forward surface TPS near the longeron closeout interface propagated out board. A second crack, 10 inches long by 1/4-inch wide, occurred along the bondline in the center of the cable tray closeout and propagated inboard. Continued propagation of both cracks would most likely result in one long crack on the forward surface of the cable tray foam. The cracks exhibited no offset and were not filled with ice or frost. The condition was acceptable for flight per the NSTS-08303 criteria.

Typical amounts of ice/frost were present in the LO2 feedline bellows and support brackets.

There were no TPS anomalies on the LO2 ET/ORB umbilical. The purge barrier (baggie) was configured properly and was holding positive purge pressure. Less than usual accumulations of ice/frost were present on the acreage areas of the umbilical. Formation of ice/frost on the separation bolt pyrotechnic canister purge vents was typical. Normal venting of nitrogen purge gas had occurred during tanking, stable replenish, and launch.

Ice/frost in the LH2 recirculation line bellows and on both burst disks was typical. An ice/frost formation with venting vapors appeared at the LH2 recirculation line-to-LH2 tank acreage interface. The LH2 feedline bellows were wet with condensate and some frost was beginning to form.

Less than usual amounts of ice/frost had accumulated on the top, aft, and outboard sides of the LH2 ET/ORB umbilical purge barrier. Typical ice/frost fingers had formed on the pyro canister and plate gap purge vents. Light ice/frost was present on both the aft and forward outboard pyrotechnic canister closeout bondlines indicating thermal shorts. A typical ice/frost ring had formed on the cable tray vent hole. Cold purge gas was leaking from the 17-inch flapper valve actuator access port foam plug closeout forward corner. Ice/frost had formed as a result. No unusual vapors or cryogenic drips had appeared during tanking, stable replenish, and launch.

The ET/ORB hydrogen detection sensor tygon tubing was in proper position prior to removal. The tubing was successfully removed from the vehicle without contacting Orbiter tiles.

The summary of Ice/Frost Team observations/anomalies consisted of nine OTV recorded items:

Anomaly 001 documented a 4-inch long by 1/4-inch wide crack in the -Y vertical strut cable tray forward surface TPS near the longeron closeout interface propagated outboard. A second crack, 10 inches long by 1/4-inch wide, occurred along the bondline in the center of the cable tray closeout and propagated inboard. Continued propagation of both cracks would most likely result in one long crack on the forward surface of the cable tray. The 1/4-inch wide cracks exhibited no offset and were not filled with ice or frost. The condition was acceptable for flight per the NSTS-08303 criteria and CR S041254C.

Anomaly 002 (documentation only) recorded ice/frost formations on the ET/ORB umbilical pyro canister purge vents and LH2 upper/outboard sections of the purge barrier (baggie). The ice and frost formations were acceptable per NSTS-08303 criteria.

Anomaly 003 (documentation only) recorded ice/frost formations in the LO2 feedline bellows and support brackets. The ice/frost formations were acceptable per NSTS-08303 criteria.

Anomaly 004 documented ice/frost accumulation on the aft dome +Z manhole cover TPS repair bondline. The condition was acceptable per the NSTS-08303 criteria.

Anomaly 005 documented ice/frost formations at the LH2 aft dome acreage-to-LH2 recirculation line interface. The ice/frost had melted prior to the time of launch.

Anomaly 006 documented an ice/frost formation on the diagonal strut tank fitting (TSE strut attach point). The condition was acceptable per the NSTS-08303 criteria.

Anomaly 007 recorded (documentation only) ice/frost accumulations on the EB fittings (EB-7 and EB-8).

Anomaly 008 documented an ice/frost formation on the aft side of the -Y vertical strut/cable tray TPS closeout. The formation was acceptable per the NSTS-08303 criteria.

Anomaly 009 (documentation only) recorded ice/frost accumulations on the uninsulated parts of the GUCP. The ice/frost formations were acceptable per NSTS-08303 criteria.

4.5 FACILITY

All SRB sound suppression water troughs were filled and properly configured for launch. There was no debris on the MLP deck or in the SRB holddown post areas.

No leaks were observed on either the LO2 or LH2 Orbiter T-0 umbilicals. Typical accumulations of ice/frost were present on the cryogenic lines and purge shrouds.

There was no apparent hydrogen leakage anywhere on the GH2 vent line or GUCP. Some ice and frost, which was expected, had accumulated on the GUCP legs and on the uninsulated parts of the umbilical carrier plate.

Visual and infrared observations of the GOX seals confirmed no leakage. No ET nosecone/footprint damage was visible after the GOX vent hood was retracted. No icicles were present on the GOX vent ducts at the time of launch.



OV-102 Columbia (14th flight), ET-56 (LWT 49), BI-057 SRB's



There was no condensate or ice/frost accumulations on the L02 tank ogive. Light condensate was present on the barrel section. There were no problems with the oval TPS repair.



Cold purge gas vapor was visible venting from the intertank



Typical amounts of ice and frost had formed in the
L02 feedline bellows and support brackets.

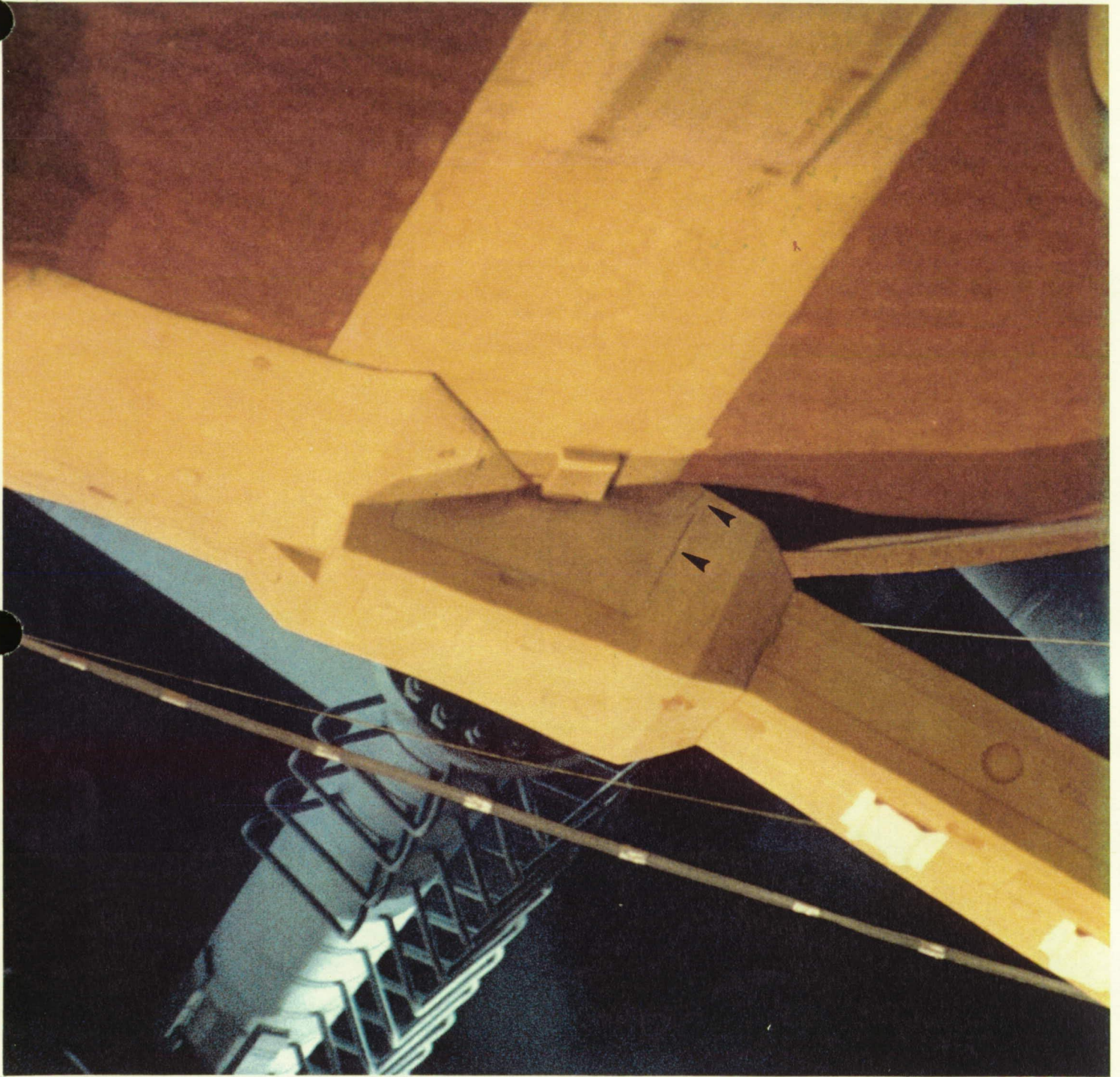

A 4-inch long crack in the -Y vertical strut cable tray forward surface TPS near the longeron closeout interface propagated outboard. A second crack, 10-inches long, occurred along the bondline in the center of the cable tray closeout and propagated inboard. Continued propagation of both cracks would most likely result in one long crack on the forward surface of the cable tray foam. The condition was acceptable for flight.

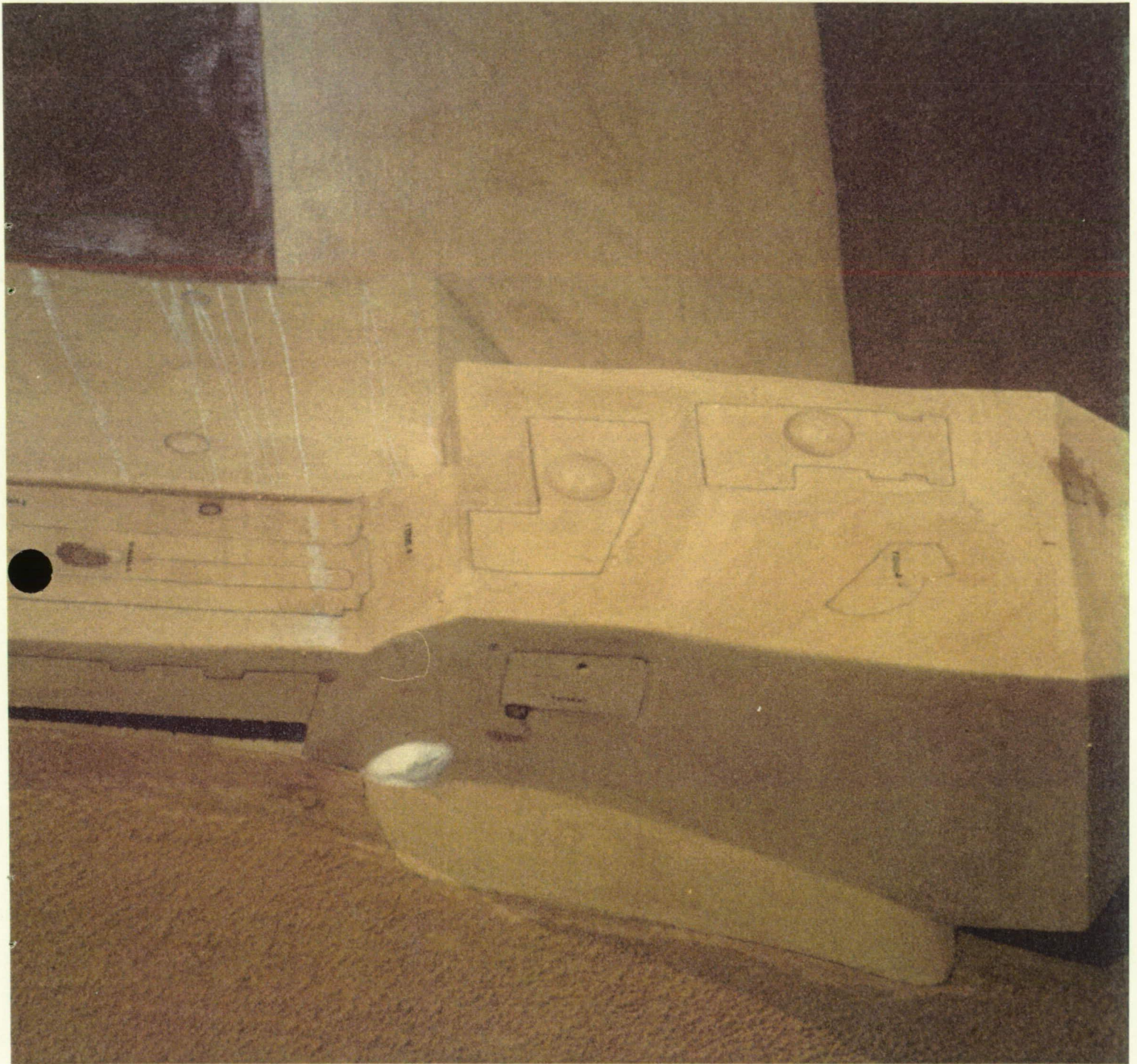

A small crack in the TPS with associated ice/frost formation was present at both +Y and -Y vertical strut-to-tank interface aft edges.

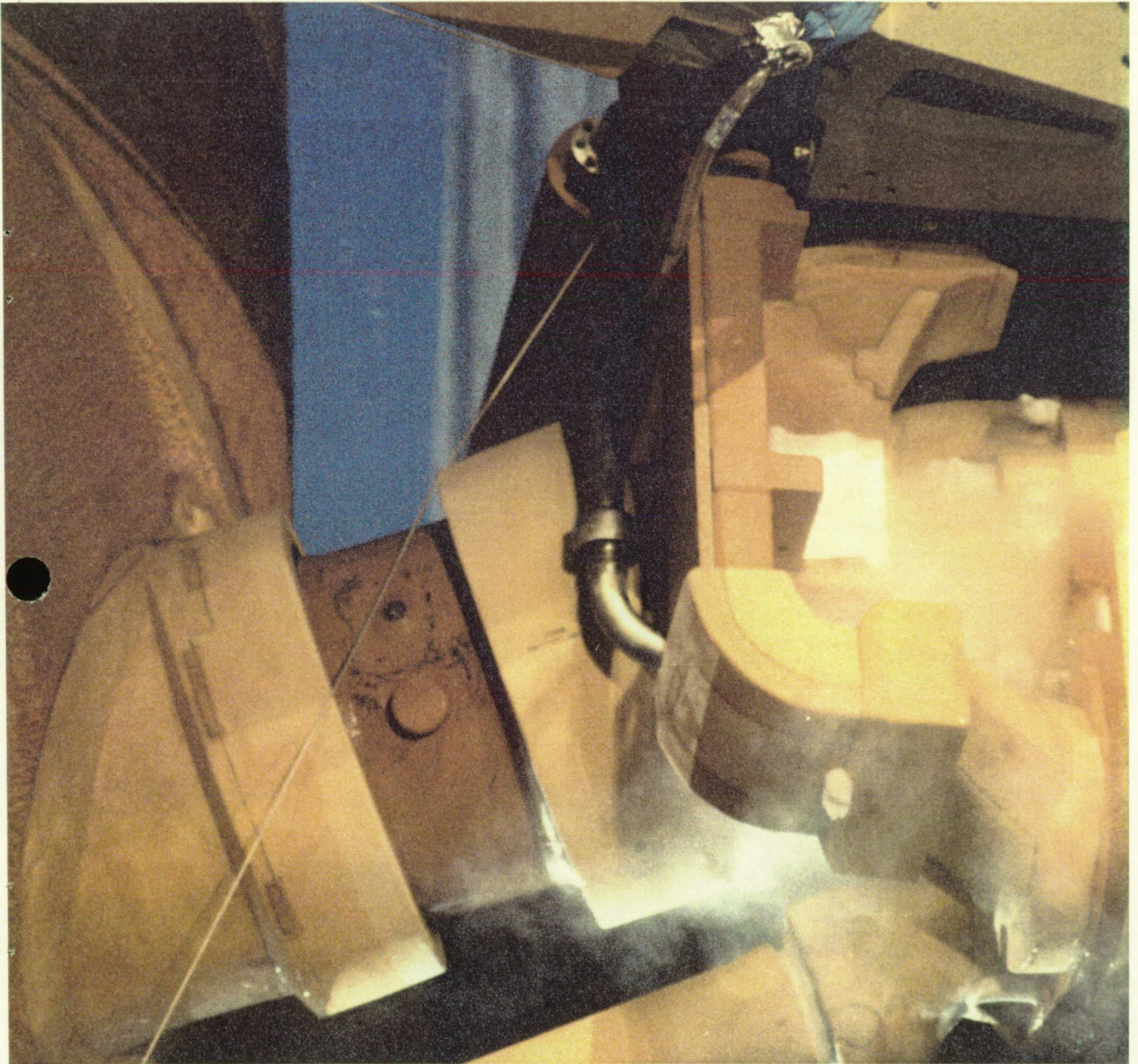

Less than usual amounts of ice/frost had formed on the ET/ORB LH2 umbilical. A typical ice/frost ring had accumulated on the cable tray vent hole. No unusual vapors or cryogenic drips had appeared during tanking, stable replenish, and launch.

5.0 POST LAUNCH PAD DEBRIS INSPECTION

The post launch inspection of the MLP, FSS and RSS was conducted on 26 April 1993 from Launch+1.5 to 3 hours. No flight hardware or TPS materials were found.

SRB holddown post (HDP) erosion was typical. All south HDP shoe EPON shim material was intact, but slightly debonded at the south-east sidewall of HDP #2. In addition, voids were observed in the sidewall shim of HDP's #1, #5 and #6. There was no visual indication of a stud hang-up on any of the south holddown posts. All of the north HDP doghouse blast covers were in the closed position and exhibited typical erosion. The SRB aft skirt purge lines were in place, but slightly damaged. The SRB T-0 umbilicals exhibited minor damage.

The GOX vent arm, OAA, and TSM's showed only minor damage. The GH2 vent arm was latched on the seventh tooth of the latching mechanism and had no loose cables (static retract lanyard). The GH2 vent line appeared to have retracted nominally. The GH2 vent line showed typical signs of SRB plume impingement. The ET intertank access structure also sustained typical plume heating effects. The GOX vent arm hydraulic panel on the 255 foot level was leaking red hydraulic fluid from a hardline/union interface. This fluid dripped all the way down to the 205 foot level.

Typical damage to the facility included:

1. A detached electrical box cover (2' x 2') on the FSS 75 foot level under the stairs.
2. Three loose signs with missing fasteners on the FSS 235 foot level elevator sidewalls. Two detached "255" signs on the 255 foot level.
3. A cracked window on the GOX vent hood -Y side.
4. A missing section (12' x 4') of masonry from the bottom of the SRB flame deflector.

All seven emergency egress slidewire baskets were secured on the FSS 195 foot level and sustained no launch damage.

An inspection/walkdown of the pad acreage, beach from UCS-10 to Titan complex 40, the beach road, the railroad tracks, the water areas around the pad and under the flight path was completed. No flight hardware or TPS material was found.

MLP-3 was configured with overpressure sensors at the top of both TSM's, at the bottom of both SRB exhaust holes, and at the bottom of the SSME exhaust hole. All sensor readings were consistent with previous launches and within nominal limits.

Patrick AFB and MILA radars were configured in a mode for increased sensitivity for the purpose of observing any debris falling from the vehicle during ascent but after SRB separation (due to the masking effect of the SRB exhaust plume). Most of the signal registrations were very weak and often barely detectable, which generally compares with the types of particles detected on previous Shuttle flights. A total of 74 particles were imaged in the T+140 to 344 second time period. Thirty-two of the particles were imaged by only one radar, 29 particles were imaged by two radars, and 13 particles were imaged by all three radars. The number and signal strength of the detected particles was generally comparable to previous missions.

Post launch pad inspection anomalies are listed in Section 10.

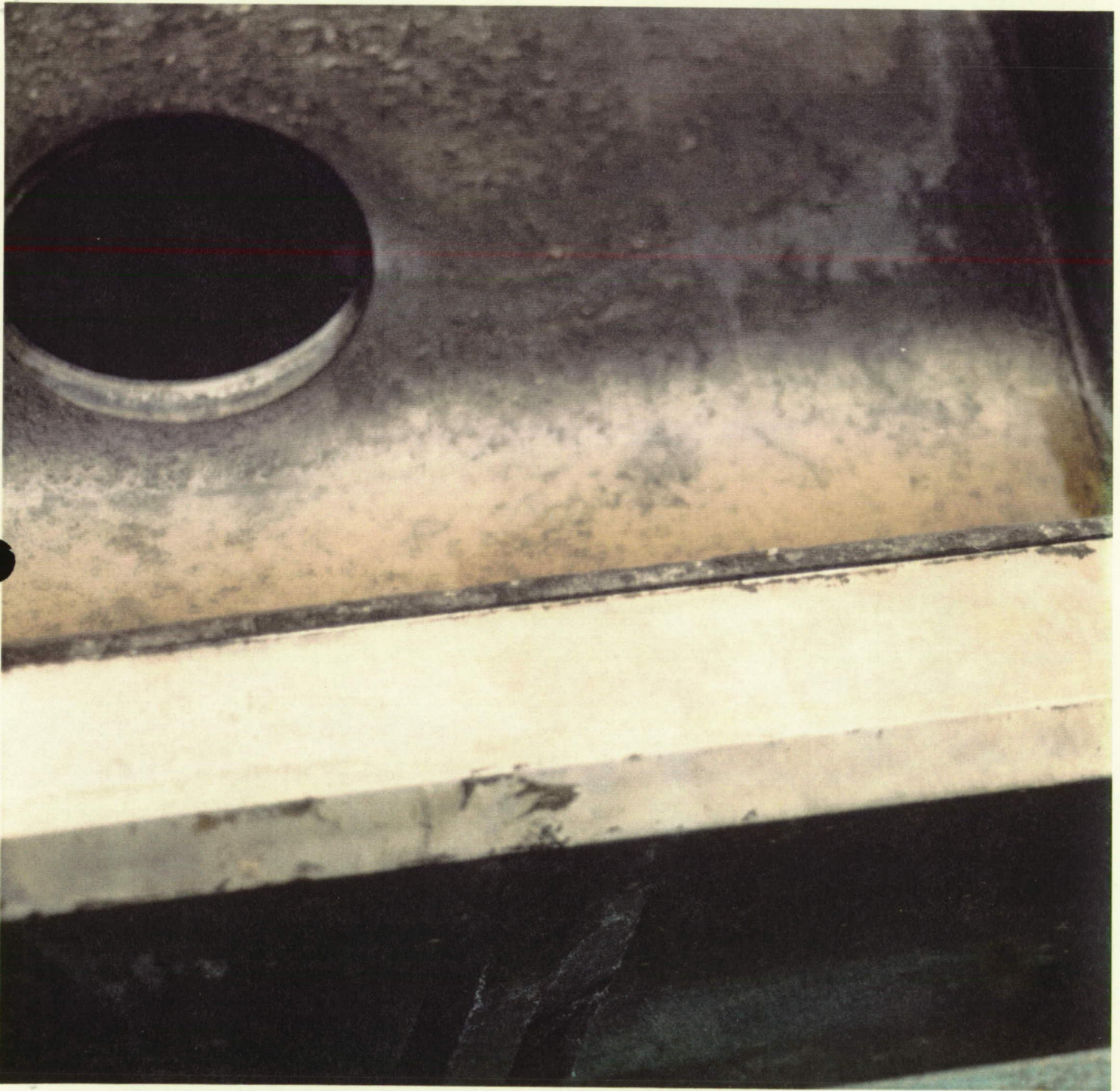

All south holddown post shoe EPON shim material was intact
but slightly debonded at the sidewall of HDP #2

6.0 FILM REVIEW AND PROBLEM REPORTS

Anomalies observed in the Film Review were presented to the Mission Management Team, Shuttle managers, and vehicle systems engineers. There were no PR's, IPR's, or IFA's as a result of the film review.

6.1 ABORT FILM AND VIDEO SUMMARY

A total of 42 films and videos, which included 14 high speed 16mm films, 7 large format 35mm films, and 21 videos, were reviewed on 29 March 1993.

There were no visual anomalies on the external surfaces of the three SSME's. Only SSME #1 ran long enough to form a Mach diamond, which existed for approximately 1 second. Frost formed on the nozzles after shutdown.

After SSME shutdown, burning hydrogen drifted upward to the base heat shield, vertical stabilizer, and under the body flap. Film E-18 showed the scorching of DMHS panels on SSME #2, burning of LH aft stinger RCS thruster paper covers, and burning of insulation on the LH2 T-0 umbilical disconnect lines.

Two thin, rectangular objects, which appeared to be pieces of purge barrier (baggie) tape, fell past the field of view (E-16, frames 4751 and 4944; E-18, frames 4630 and 5200).

SSME ignition caused the loss of small pieces of tile surface coating material on the base heat shield and RH aft RCS stinger (E-17, 19).

There were no External Tank anomalies. Maximum deflection (vehicle "twang") was approximately 14 inches in the -Z direction and 9 inches in the +Z direction.

There were no SRB anomalies.

There appeared to be good FIREX water spray coverage of the SSME area, the LH2/LO2 T-0 umbilical disconnects, and up to the ET/ORB LH2 umbilical. Due to an alignment problem with a FIREX nozzle, no water reached the LO2 ET/ORB umbilical. Facilities personnel checked the alignment procedure and will take corrective action for the STS-56 launch.

There were no anomalies with the hydrogen burn ignitors.

6.2 LAUNCH FILM AND VIDEO SUMMARY

A total of 100 films and videos, which included forty-one 16mm films, twenty 35mm films, four 70mm films, and thirty-five videos, were reviewed starting on launch day.

No major vehicle damage or lost flight hardware was observed that would have affected the mission.

Prior to ignition, free burning hydrogen drifted under the body flap. SSME start-up, Mach diamond formation, and gimbal profile appeared normal (RSS and C/S-2 STI, OTV 051, 063, 070, 071, E-1, 5). Several flashes occurred in the SSME plumes prior to and after T-0 (E-2, 3). An orange streak occurred in the SSME plume at 14:50:01.199 GMT. Numerous white flashes were visible in the SSME plume after tower clear (E-52).

Fore-and-aft movement of the Orbiter base heat shield in the centerline area between the SSME cluster occurred during engine start-up. The motion was similar to that observed on previous launches (E-76, 77).

SSME ignition caused numerous pieces of ice to fall from the ET/Orbiter umbilicals. There were no unusual vapors or cryogenic drips from the ET/ORB umbilicals during tanking, stable replenish, ignition, liftoff, or tower clear (OTV 009, 050, 054, 063, 064).

Two pieces of ice fell from the LO2 feedline bellows, XT-1119, but did not contact Orbiter tiles (E-65).

SSME ignition vibration/acoustics caused the loss of tile surface coating material from a small area on a base heat shield tile outboard of SSME #3 (E-17).

A white debris particle, which appeared to be tumbling, drifted in an easterly direction prior to T-0 (E-30, 36).

The Orbiter LH2 and LO2 T-0 umbilicals disconnected and retracted properly (OTV 049, 050, 063). A dark, slender debris object fell from the right aft RCS stinger and was most likely a tile gap filler (E-17, frame 4255; E-20, frame 4805). Ice, 12" x 2" in size, fell from the Orbiter LH2 T-0 umbilical interface after the carrier plate had disconnected and started to retract (E-77). A 3" x 0.5" GSE shim fell from the LH2 T-0 umbilical carrier plate shortly after T-0 (E-18, frame 4206).

A small debris particle entered the field-of-view left side, moved in the direction of the LH SRB, bounced off the factory joint at T-0, and traveled towards the facility. No damage to flight hardware was visible (E-48).

GUCP disconnect and retraction from the ET was normal (E-33, 34). The GH2 vent arm retracted and latched with no rebound. Some slack in the static retract lanyard caused the cable to contact the facility X-brace during latchback (OTV 060, E-41, 42, 48, 50)

No stud hang-ups occurred on any of the holddown posts. No debris fell from any of the aft skirt HDP DCS/stud holes. Two pieces of shim material fell from the HDP #3 area at liftoff (E-10).

Numerous pieces of SRB throat plug material were ejected out of the RH SRB exhaust hole after T-0 (E-1, 5, 15, 25). Numerous white objects in the plume (after the vehicle cleared the tower) were most likely pieces of ice from the cryogenic cross-country lines. A particularly large piece was visible at frame 1732, E-60. A piece of SRB sound suppression water trough material was visible near the north side of the LH2 TSM after liftoff (E-3, frame 4874).

Water vapor/condensate trailed from the rudder/speed brake drain hole after liftoff (E-40).

Three flashes, most likely debris-induced, occurred in the SSME plume during ascent (TV-4A, TV-21A, E-222).

Clusters of particles falling aft of the Orbiter after completion of the roll maneuver were traced to the forward RCS thrusters as pieces of RCS paper covers. Other pieces of RCS paper covers were visible passing over the Orbiter wings (E-212, 213, 222).

An electromagnetic disturbance was detected by UHF Receiver #4 and the Lightning Detector and Ranging System (LDAR) in the vicinity of the vehicle 47-50 seconds MET. Although localized flow condensation formed on various parts of the vehicle during ascent, no sign of the electrostatic discharge event was visible on the long range trackers.

Movement of the body flap was similar to previous flights (E-212).

Local flow condensation at various points on the vehicle was typical (E-207, 213, 222). Exhaust plume recirculation appeared typical. SRB plume tailoff and separation appeared normal (E-208, 212).

Frustum separation from the forward skirts appeared normal. Main parachute deployment, reefing, inflation, and jettison at splash down was nominal. However, one chute on the RH SRB was ripped or torn approximately 25 feet in length along a seam. Nozzle severance debris was typical (E-301, 302).

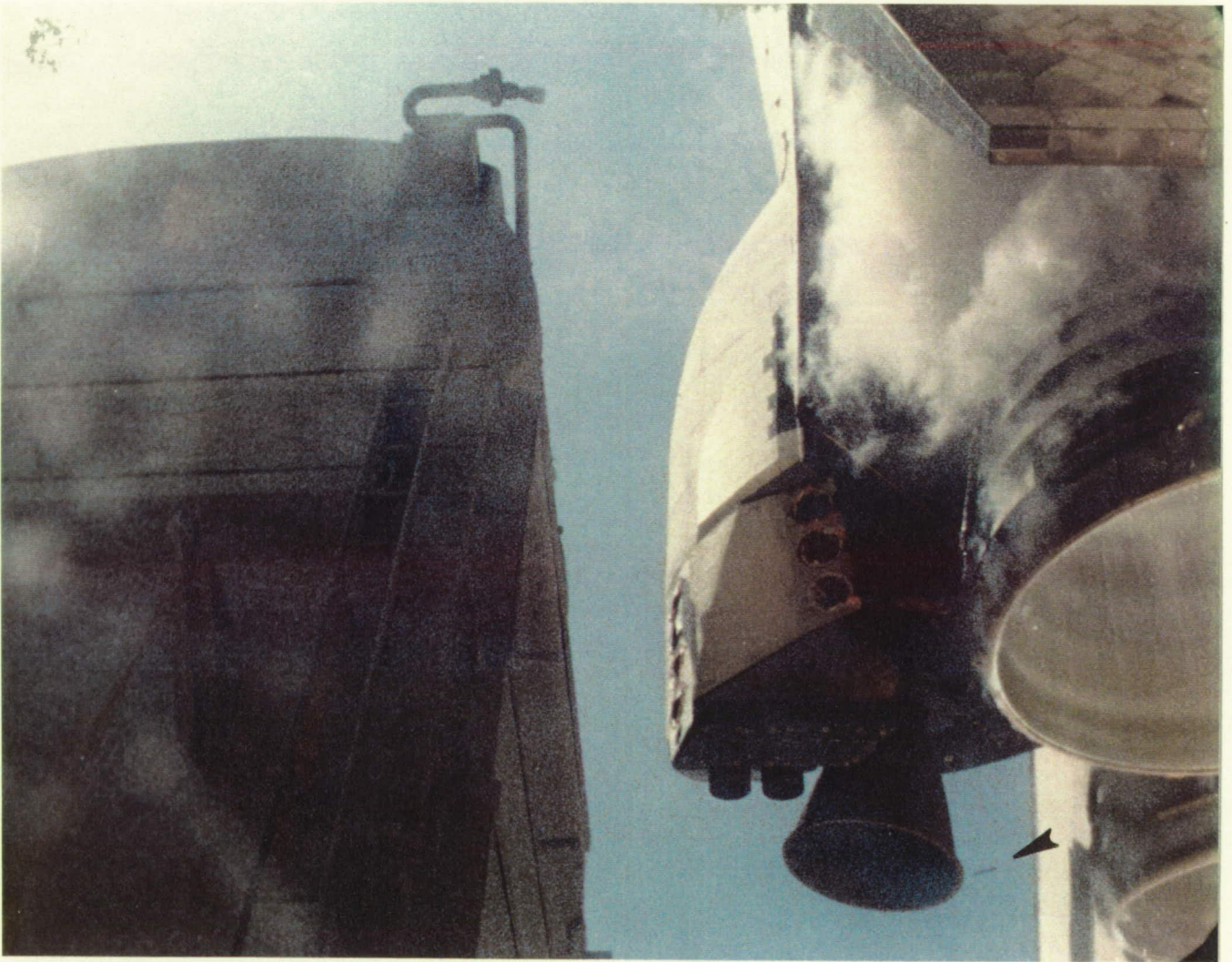

A dark, slender, debris object fell from the right aft RCS stinger area and was most likely a tile gap filler

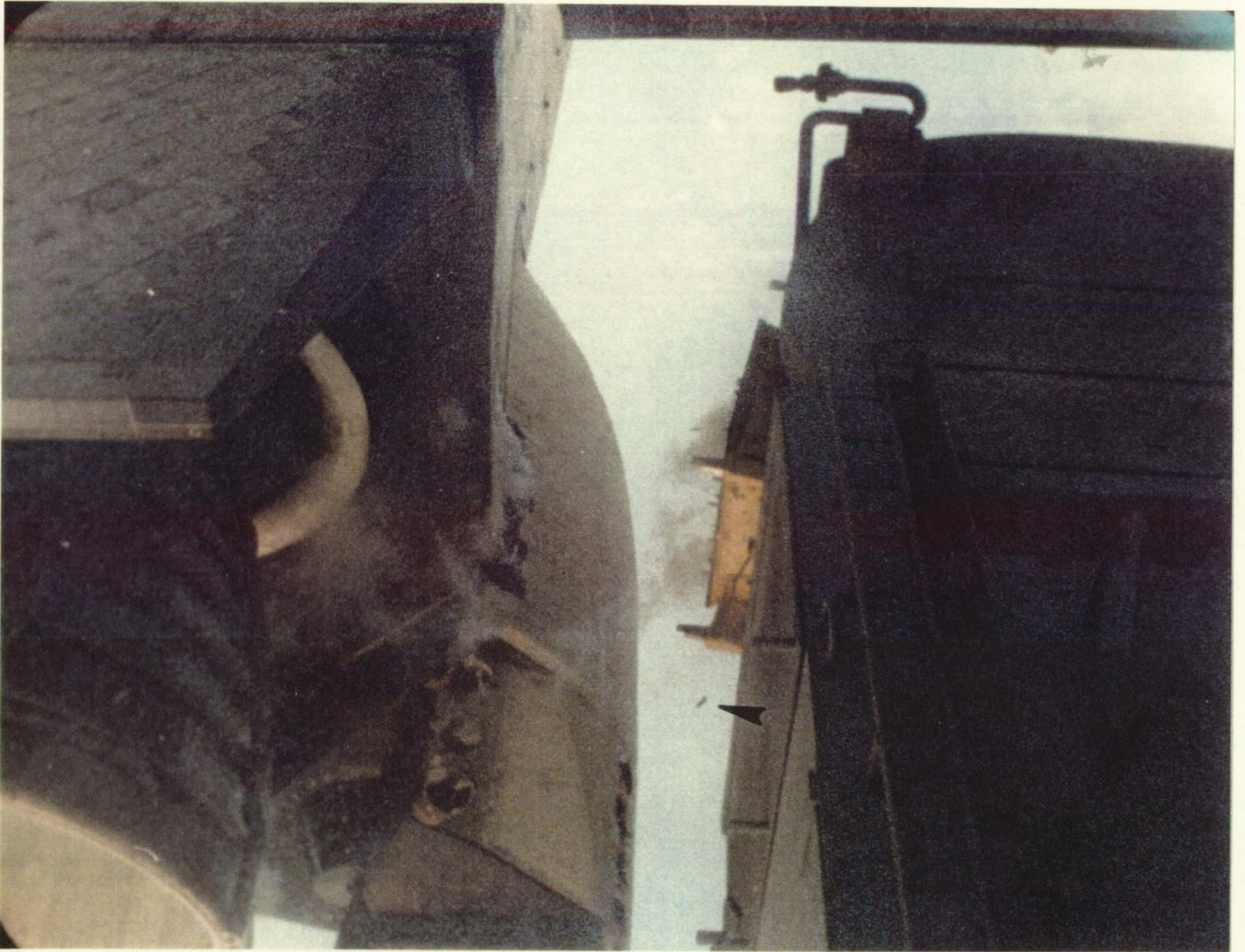

A 3" x 0.5" GSE shim fell from the LH2 T-0 umbilical carrier plate shortly after T-0

6.3 ON-ORBIT FILM AND VIDEO SUMMARY

DTO-0312 was performed by the flight crew and thirty-four hand held still images and a 16mm motion picture film were obtained of the ET after separation from the Orbiter. OV-102 was equipped to carry three umbilical cameras. The 16mm camera with the 10mm lens failed to run on this flight. Direct sunlight on the umbilical cameras made analysis of these films more difficult.

No major vehicle damage or lost flight hardware was observed that would have been a safety of flight concern. There appeared to be no anomalies or venting of gaseous hydrogen from the ET/ORB LH2 umbilical recirculation line 4-inch valve (ET side). No IFA's were proposed as a result of this film analysis.

SRB separation from the ET was nominal. Separation of the -Y ET/SRB upper and diagonal struts appeared normal. No loss of TPS from the upper strut fairing was visible though small pieces of ET foam fell aft before and after SRB separation. No anomalies were observed on the LH SRB segment cases and joints, forward skirt, and frustum. The left forward BSM aero heat shield covers were fully opened and latched.

ET separation from the Orbiter appeared nominal. The BSM burn scars on the LO2 tank were typical. No anomalies were observed on the nosecone, LO2 tank acreage, PAL ramps, RSS antennae, flight door, bipod ramps, aft hard point, and aft dome acreage. Three long, slender objects, possibly pieces of white RTV appeared as the LH2 ET/ORB umbilical separated/vented. One of the objects appeared in front of the vertical cable tray (frame 2900; two of the objects originated from an area behind the cable tray (frame 3480).

Six divots, 6-8 inches in diameter, were present in the LH2 tank-to-intertank flange closeout: 4 in the -Y+Z quadrant and 2 in the -Y-Z quadrant. One 8-inch divot occurred in the inter-tank acreage between the left bipod ramp closeout and the -Y thrust panel (-Y+Z quadrant). At least 15-20 small "popcorn" type divots were visible on intertank stringer heads in an area just forward of the bipods. Two of those divots, measuring 6 inches in length, occurred just forward of the left bipod spindle area.

The right bipod jack pad closeout was missing and green primer exposed. Due to sun angle/image degradation, no detail on the left jack pad closeout could be discerned.

Five 6-inch divots were present in the LH2 tank acreage: one aft of the RH bipod ramp and four in the -Y+Z quadrant near the LH2 tank-to-intertank flange closeout.

Erosion and "popcorning" on the L02 feedline flange closeouts and support brackets was typical. TPS erosion had also occurred on several of the pressurization line support ramps and on the +Y thrust strut flange closeout. Nine small divots were visible in the LH2 tank acreage in the general area of XT-1973.

Frozen hydrogen, but no TPS or structural damage, was visible on the LH2 ET/ORB umbilical interface. Erosion and charring of TPS on the aft surfaces of the LH2 umbilical support structure and cable tray was typical. One intact piece of hydrogen fire detection butcher paper was still attached by one side of the adhesive

TPS was missing from the L02 ET/ORB umbilical cable tray horizontal section. More than usual erosion and numerous divots were visible on the cable tray vertical section.

Plume recirculation and aft dome heating caused the usual charring and "popcorning" of the NCFI foam.

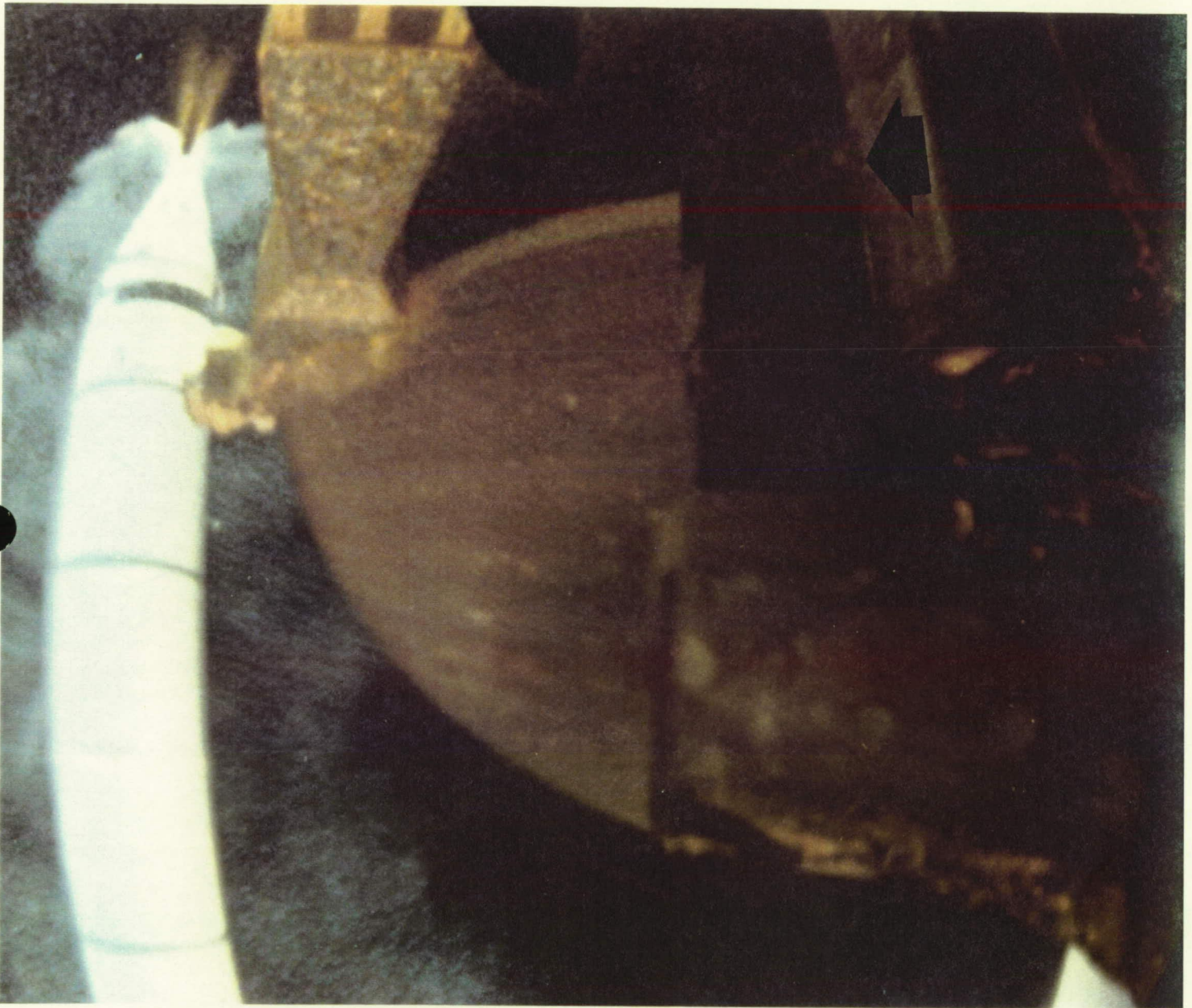

SRB separation from the ET was nominal. Tailoff of the Booster Separation Motors in the LH frustum is still visible. Erosion and charring of TPS on the aft surfaces of the LH2 umbilical support structure and cable tray was typical. Note intact piece of hydrogen fire detection paper still attached by one side of the adhesive (arrow).



Frozen hydrogen, but no TPS or structural damage, was visible on the LH2 ET/ORB umbilical interface. There appeared to be no anomalies or venting of gaseous hydrogen from the recirculation line 4-inch valve (ET side).



The right (+Y) bipod jack pad closeout was missing and green primer exposed. Three 6-inch divots are visible in the LH2 tank acreage TPS near the intertank splice. At least 15-20 small, shallow divots occurred in the intertank acreage TPS forward of the bipods.



Six divots, 6-8 inches in diameter, were present in the LH2 tank-to-intertank flange closeout. One 8-inch divot occurred in the intertank acreage between the left bipod ramp and the -y thrust panel. Four 6-inch divots are visible in the LH2 tank acreage TPS near the intertank splice.

6.4 LANDING FILM AND VIDEO SUMMARY

A total of seven 16mm high speed films were reviewed.

Orbiter performance in the Heading Alignment Circle (HAC) and final approach appeared normal. There were no anomalies when the landing gear was extended. Touchdown of the main gear was nominal.

The drag chute was deployed just after breakover, but before the nose gear contacted the runway. Drag chute deployment appeared nominal though the parachute risers contacted the vertical stabilizer "stinger" tiles. A crosswind blew the drag chute to the right of the Orbiter centerline.

Touchdown of the nose landing gear was smooth. There were no anomalies during rollout.

7.0 SRB POST FLIGHT/RETRIEVAL DEBRIS ASSESSMENT

Both Solid Rocket Boosters were inspected for debris damage and debris sources at CCAFS Hangar AF on 28 April 1993 from 0900 to 1100 hours. From a debris standpoint, both SRB's were in good condition.

7.1 RH SOLID ROCKET BOOSTER DEBRIS INSPECTION

The RH frustum was missing no TPS, but had 32 MSA-2 debonds over fasteners. Minor localized blistering of the Hypalon paint had occurred along the 395 ring (Figure 7). All BSM aero heatshield covers were locked in the fully opened position, though the two left cover attach rings had been bent by parachute riser entanglement.

The RH forward skirt acreage exhibited no debonds or missing TPS. Both RSS antennae covers/phenolic base plates were intact. Minor blistering of the Hypalon paint occurred on the systems tunnel cover and around the ET/SRB attach point (Figure 8). No pins were missing from the frustum severance ring. The forward separation bolt appeared to have separated cleanly.

The Field Joint Protection System (FJPS) closeouts were generally in good condition. Trailing edge damage to the FJPS and the GEI cork runs were attributed to debris resulting from severance of the nozzle extension.

Separation of the aft ET/SRB struts appeared normal. The ET/SRB aft struts, ETA ring, IEA, and IEA covers appeared undamaged. K5NA closeout material, 3" x 2" in size, was missing from the upper strut fairing. All three aft booster stiffener rings also appeared undamaged. The aft booster stiffener ring splice plate closeouts were intact and no K5NA material was missing.

The phenolic material on the kick ring was delaminated. The K5NA closeouts (protective domes) on the kick ring forward and aft fasteners are no longer used. RTV-133 has replaced the K5NA over the forward fasteners. The aft skirt acreage TPS was generally in good condition but was missing a 3-inch diameter piece of MSA-2 on ring frame 1894 fasteners near the -Y axis (Figure 9).

All four Debris Containment System (DCS) plungers were seated, though an NSI detonator was wedged between the HDP #4 stud hole wall and the DCS plunger. A piece of the HDP #4 EPON shim may have been detached prior to splashdown. Part of the HDP #3 inboard sidewall EPON shim material was missing prior to water impact and may have been the two pieces observed in the film review falling from the aft skirt foot/holddown post area.

FIGURE 7. RIGHT SRB FRUSTUM

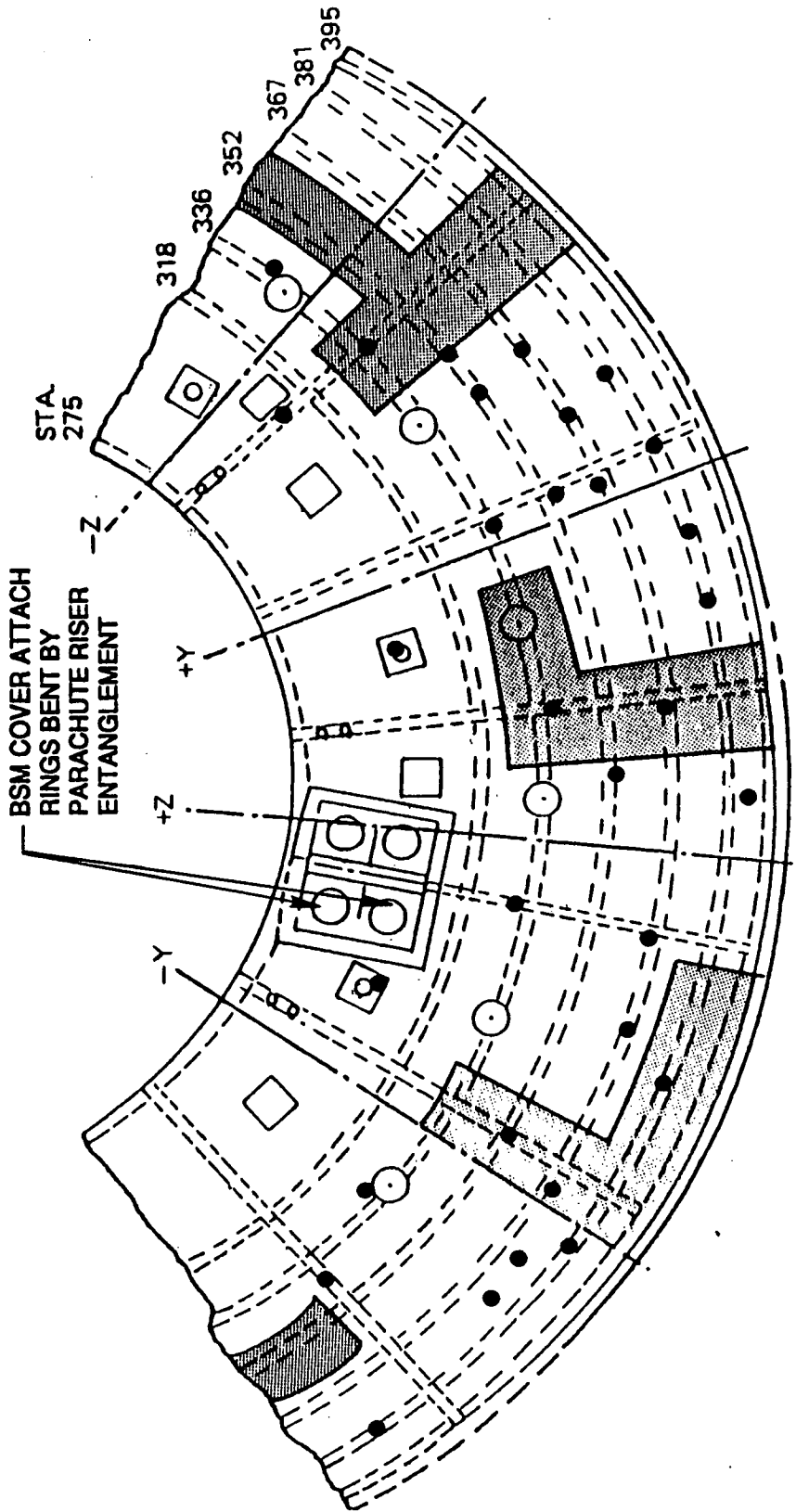
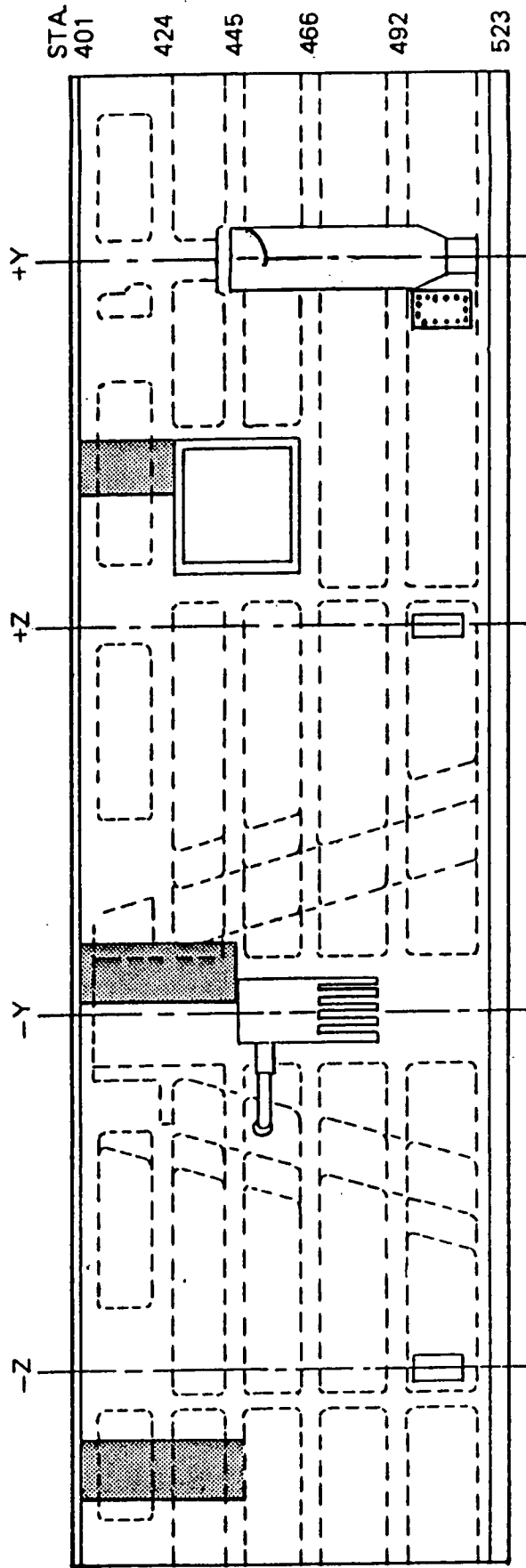

FIGURE 8. RIGHT SRB FWD SKIRT



TPS MISSING
NONE

DEBONDS
NONE

TYPICAL BLISTERING OF
HYPALON PAINT ON THE
SYSTEMS TUNNEL COVER
AND AROUND ET/SRB
ATTACH FITTING

FIGURE 9. RIGHT SRB AFT SKIRT EXTERIOR TPS

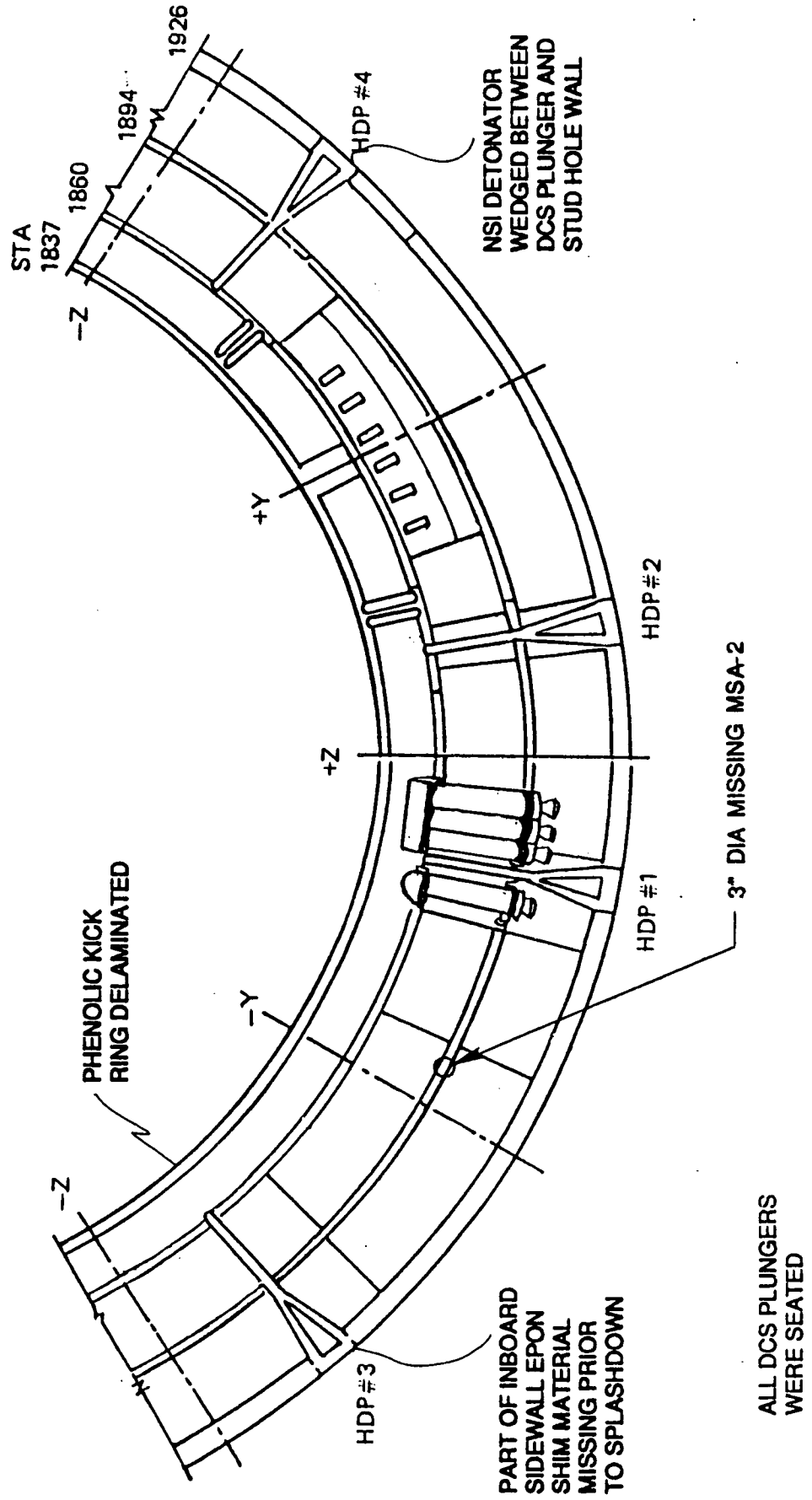

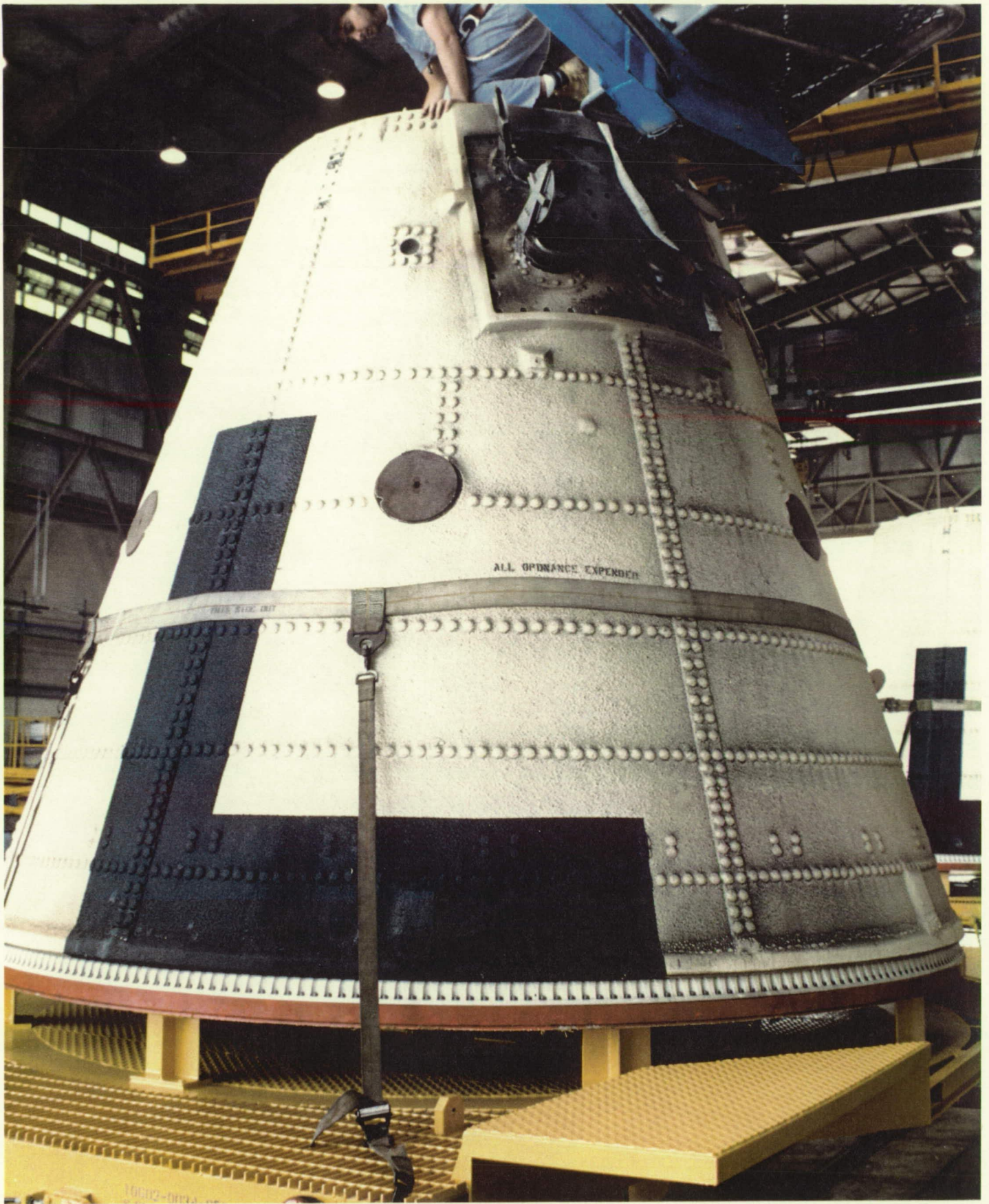

The RH frustum was missing no TPS, but had 32 MSA-2 debonds over fasteners. All BSM aero heatshield covers were locked in the fully opened position, though the two left cover attach rings had been bent by parachute riser entanglement.

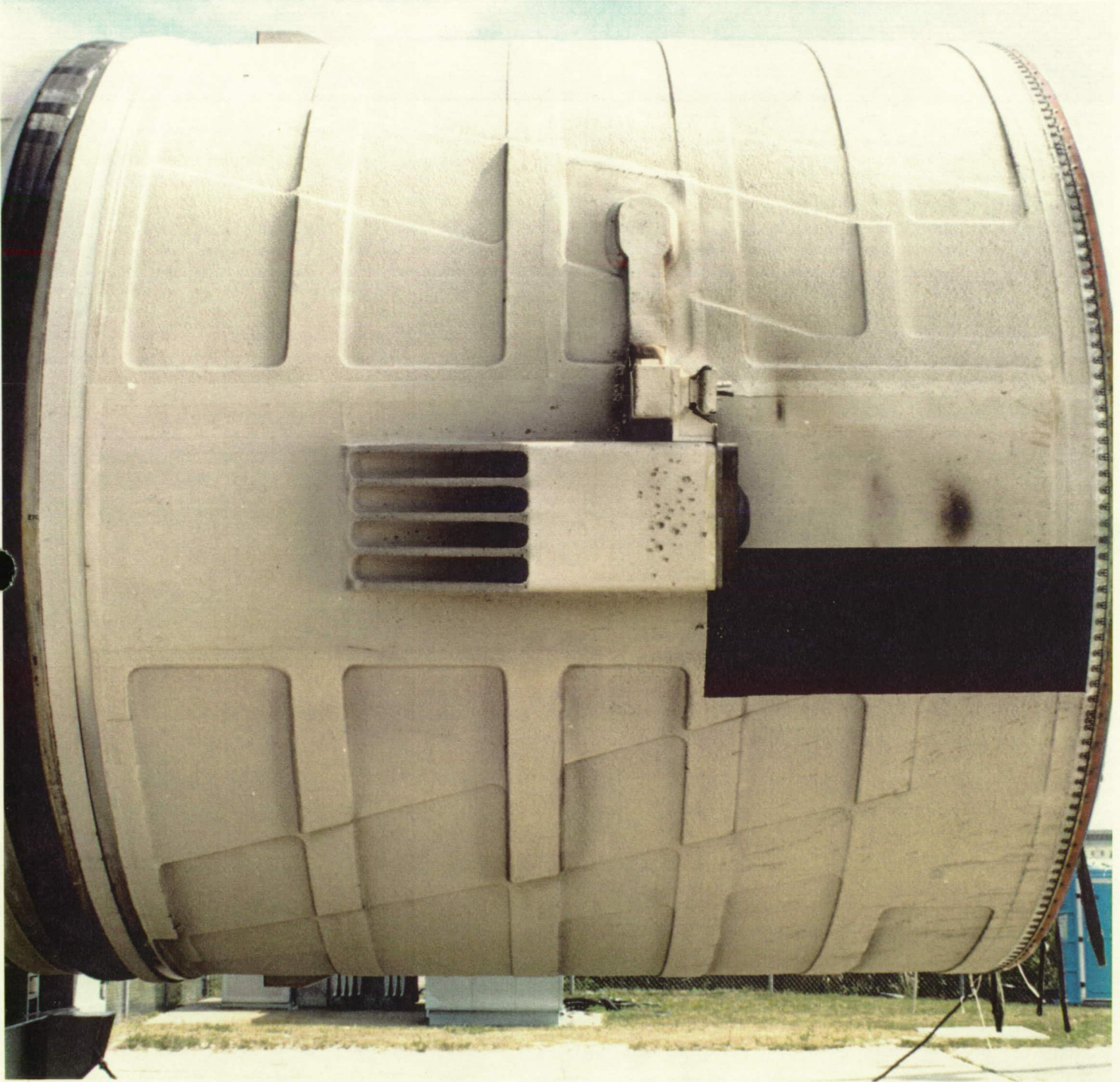

The RH forward skirt acreege MSA-2 exhibited no debonds or missing TPS. Both RSS antenna covers/phenolic base plates were intact.

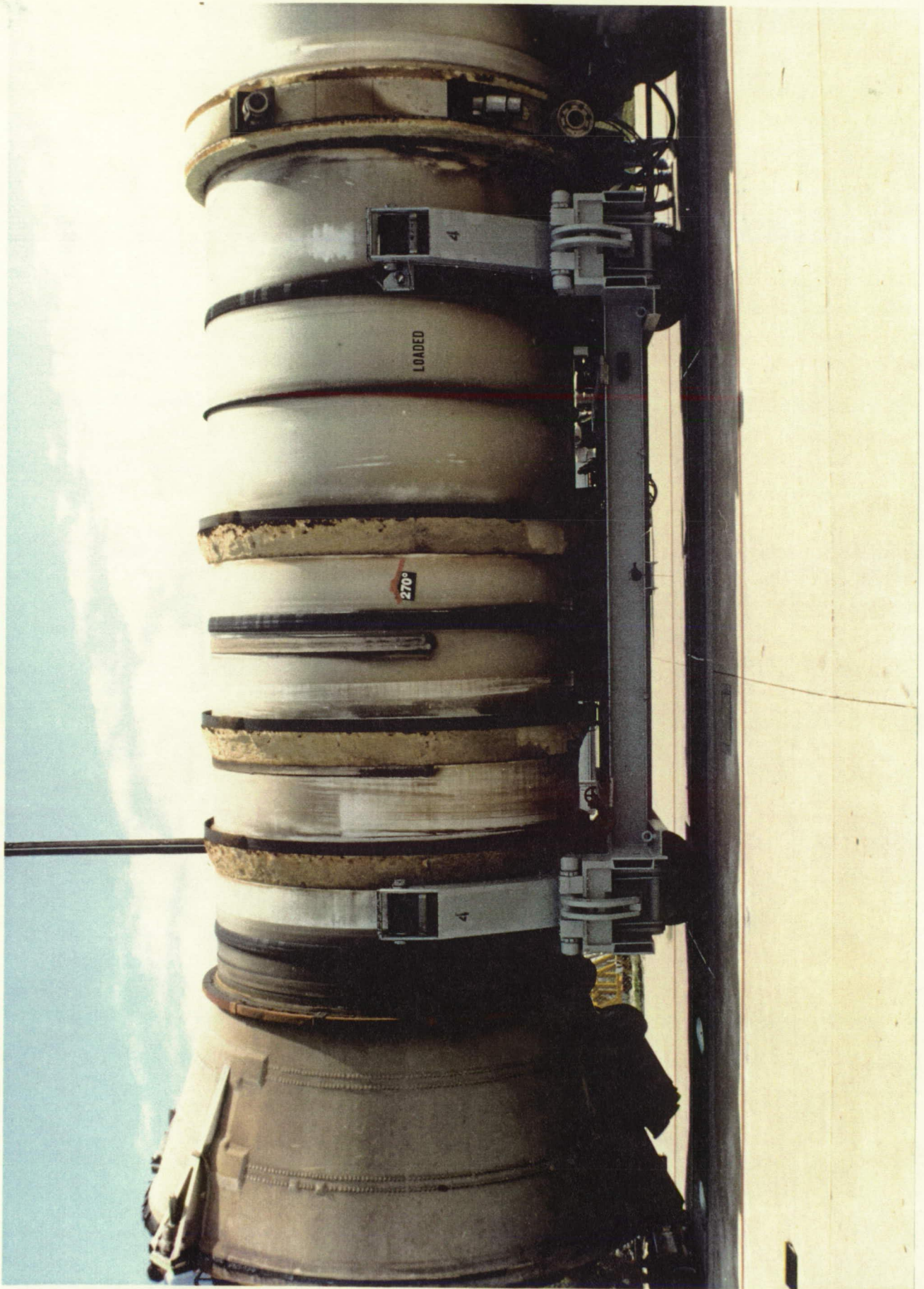

Post flight condition of the RH aft booster. The ET/SRB aft struts, ETA ring, IEA covers, IEA, and aft booster stiffener rings appeared undamaged.



K5NA, 3"x2" in size, was missing from the upper strut fairing

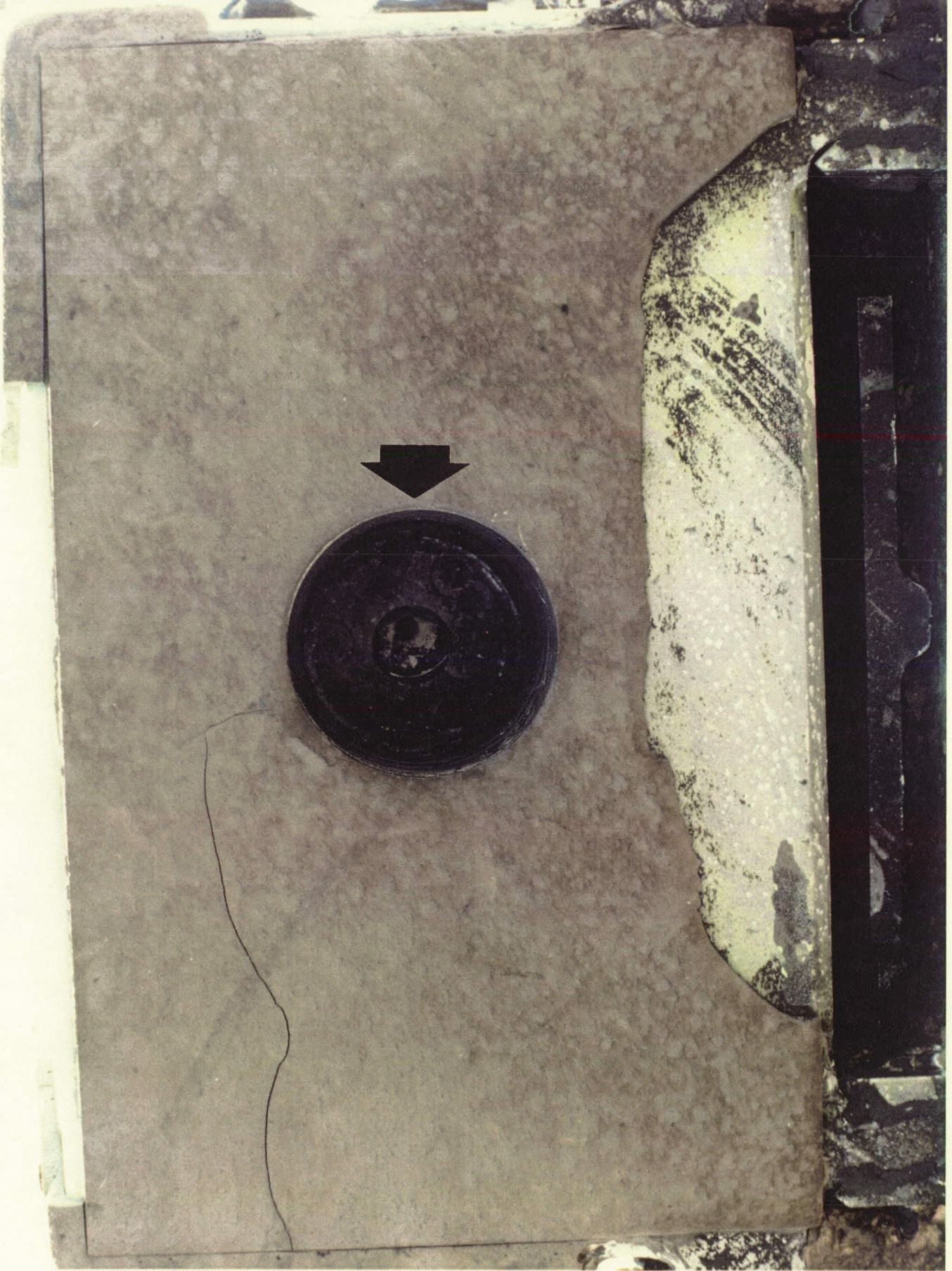

Although the DCS plunger was seated, an NSI detonator was wedged between the HDP #4 stud hole wall and the plunger

7.2 LH SOLID ROCKET BOOSTER DEBRIS INSPECTION

The LH frustum had a total of 21 MSA-2 debonds over fasteners. A 1-inch diameter piece of MSA-2 was missing from an area between the 275 and 318 ring frames near the -Z axis (Figure 10). Minor localized blistering of the Hypalon paint had occurred along the 395 ring. The BSM aero heat shield covers were locked in the fully opened position, though the two left cover attach rings had been bent by parachute riser entanglement.

The LH forward skirt acreage exhibited no debonds or missing TPS. Both RSS antennae covers/phenolic base plates were intact. Minor blistering of the Hypalon paint occurred near the ET/SRB attach point and on the systems tunnel cover (Figure 11). No pins were missing from the frustum severance ring. The forward separation bolt appeared to have separated cleanly.

The Field Joint Protection System (FJPS) closeouts were in good condition. In general, minor trailing edge damage to the FJPS and the GEI cork runs were attributed to debris resulting from severance of the nozzle extension.

Separation of the aft ET/SRB struts appeared normal. The ET/SRB aft struts, ETA ring, IEA, and IEA covers appeared undamaged. K5NA closeout material, 5" x 1" in size, was missing from the upper strut fairing. All three aft booster stiffener rings appeared undamaged. The stiffener ring splice plate closeouts were intact and no K5NA material was missing. A debond, 8 inches in circumferential length by 0.5 inches deep, was detected at the 145 degree radial position on the aft factory joint. A K5NA repair was missing from this same location.

The phenolic material on the kick ring was delaminated. The K5NA closeouts (protective domes) on the kick ring forward and aft fasteners are no longer used. RTV-133 has replaced the K5NA over the forward fasteners. Five areas of MSA-2, the largest of which measured 3" x 2.5", were missing from the aft skirt acreage TPS. Two other 3 inch diameter areas of MSA-2 were debonded. Samples were removed for analysis (Figure 12).

The HDP #5 DCS plunger was obstructed by frangible nut halves. The other three DCS plungers were properly seated. HDP #8 EPON shim material, 12" x 3" in size, was missing prior to splashdown. The substrate was sooted/charred.

FIGURE 10. LEFT SRB FRUSTUM

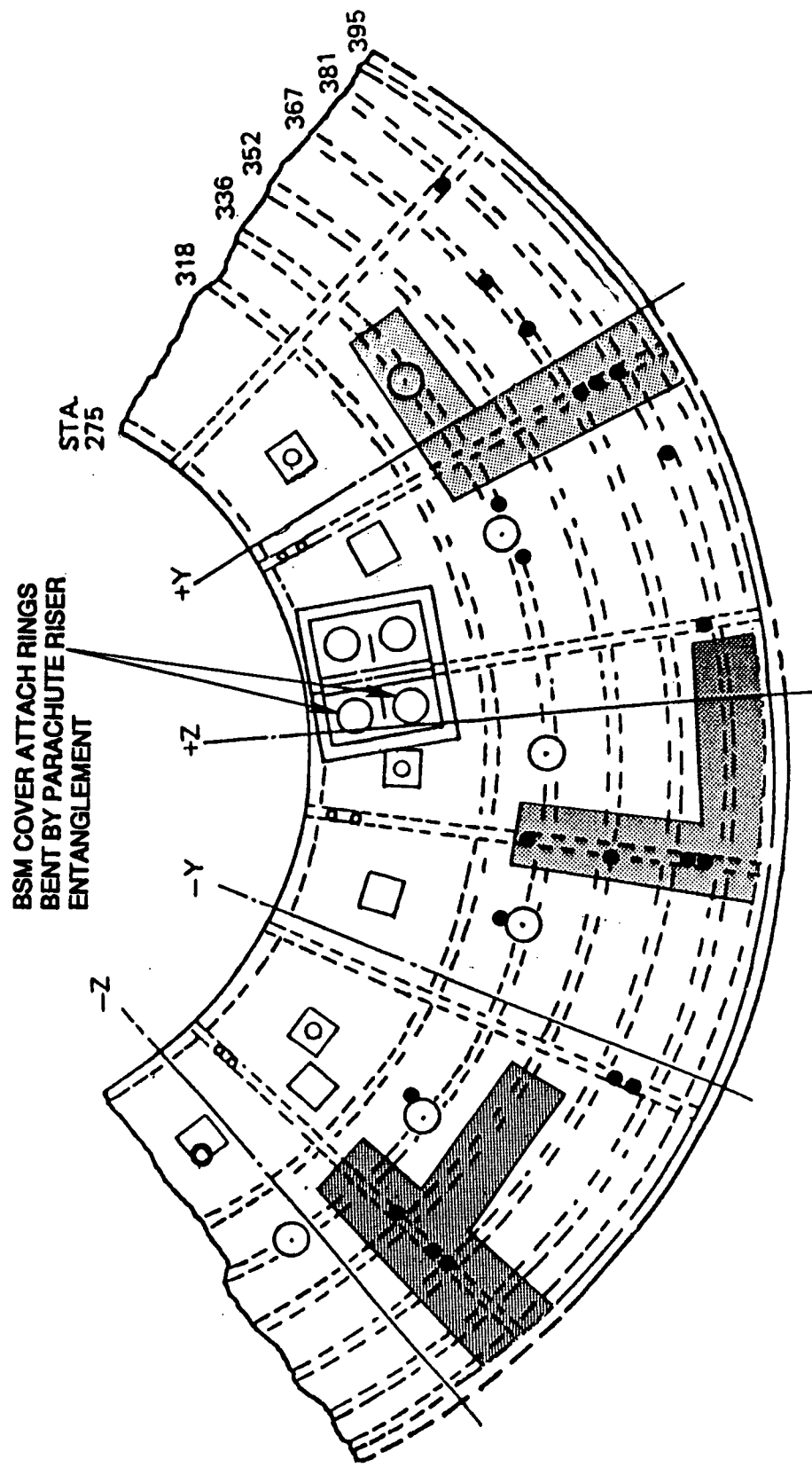

BSM COVER ATTACH RINGS
BENT BY PARACHUTE RISER
ENTANGLEMENT

MISSING TPS
○ 1" DIA (OPEN
BLISTER WITH
LAYERED MSA)

DEBONDS
● 21

FIGURE 11. **LEFT SRB FWD SKIRT**

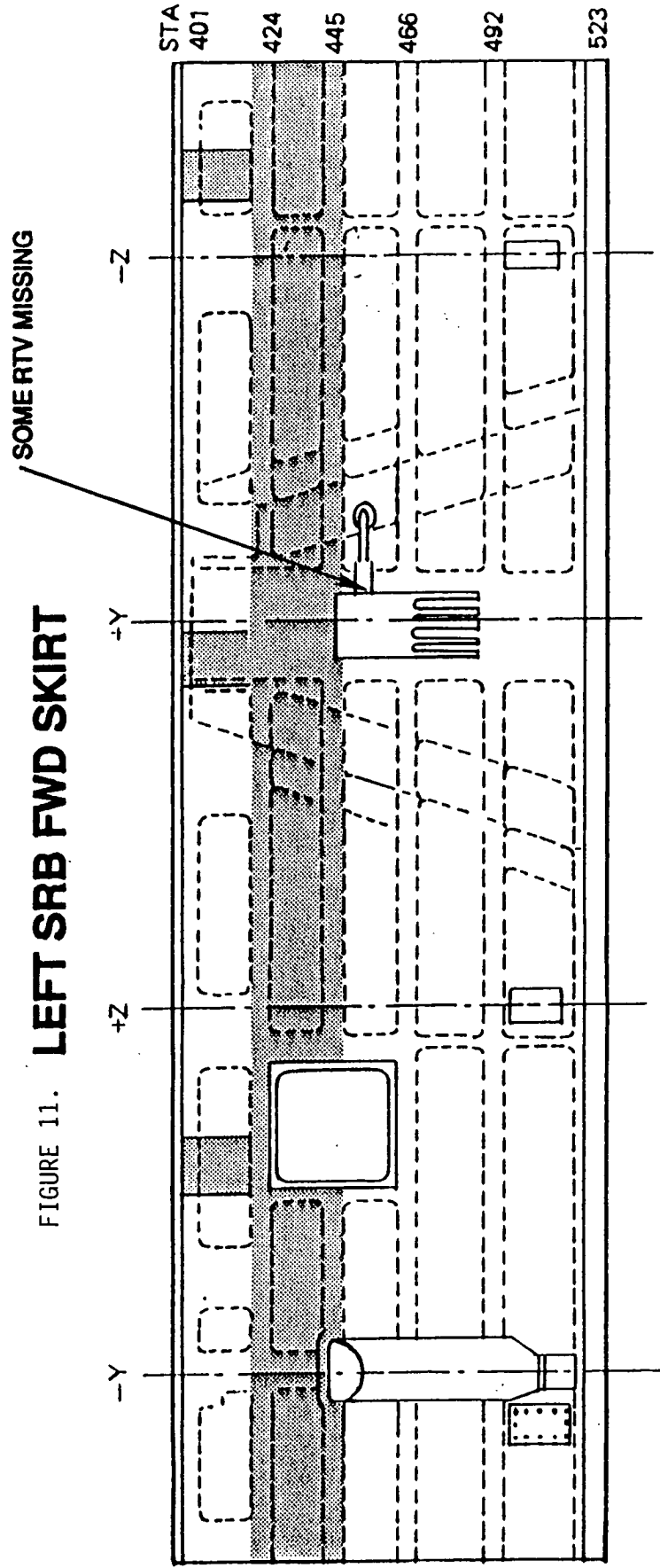

TPS MISSING

NONE

DEBONDS

NONE

TYPICAL BLISTERING OF
HYALON PAINT ON
SYSTEMS TUNNEL COVER
AND AROUND ET/SRB ATTACH
FITTING

FIGURE 12. LEFT SRB AFT SKIRT EXTERIOR TPS

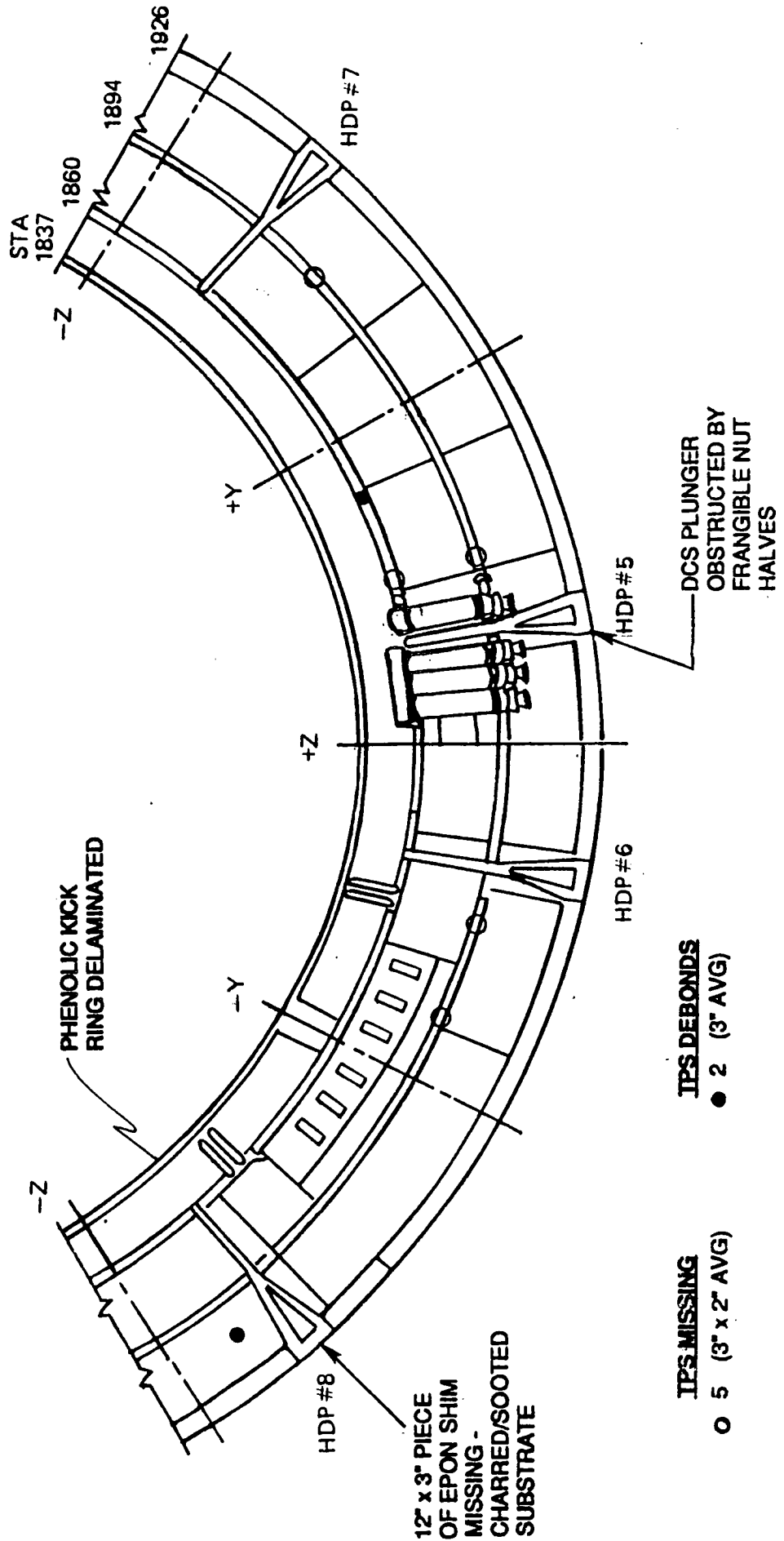

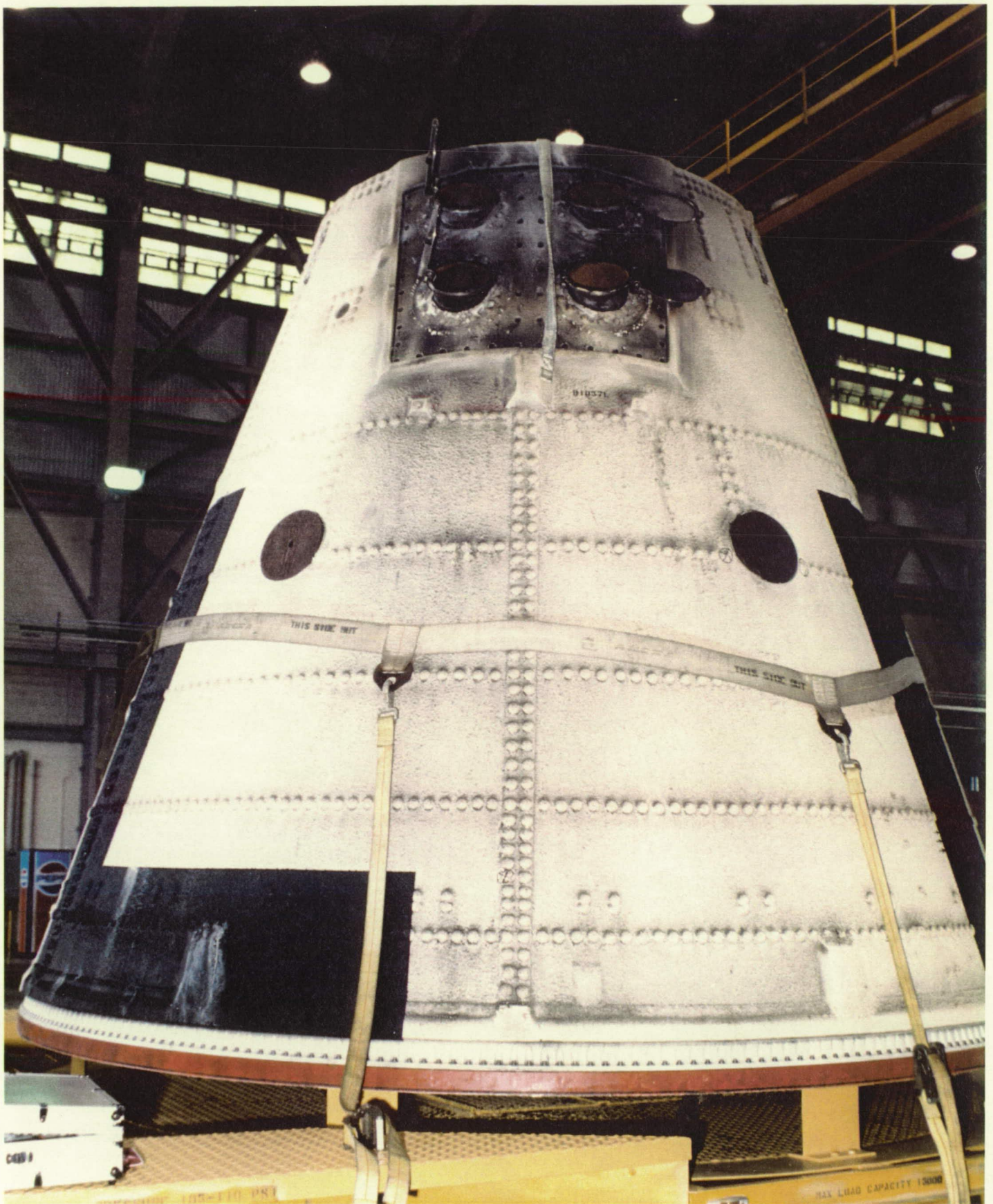

The LH frustum had a total of 21 MSA-2 debonds over fasteners. The BSM aero heat shield covers were locked in the fully opened position, though the two left cover attach rings had been bent by parachute riser entanglement.

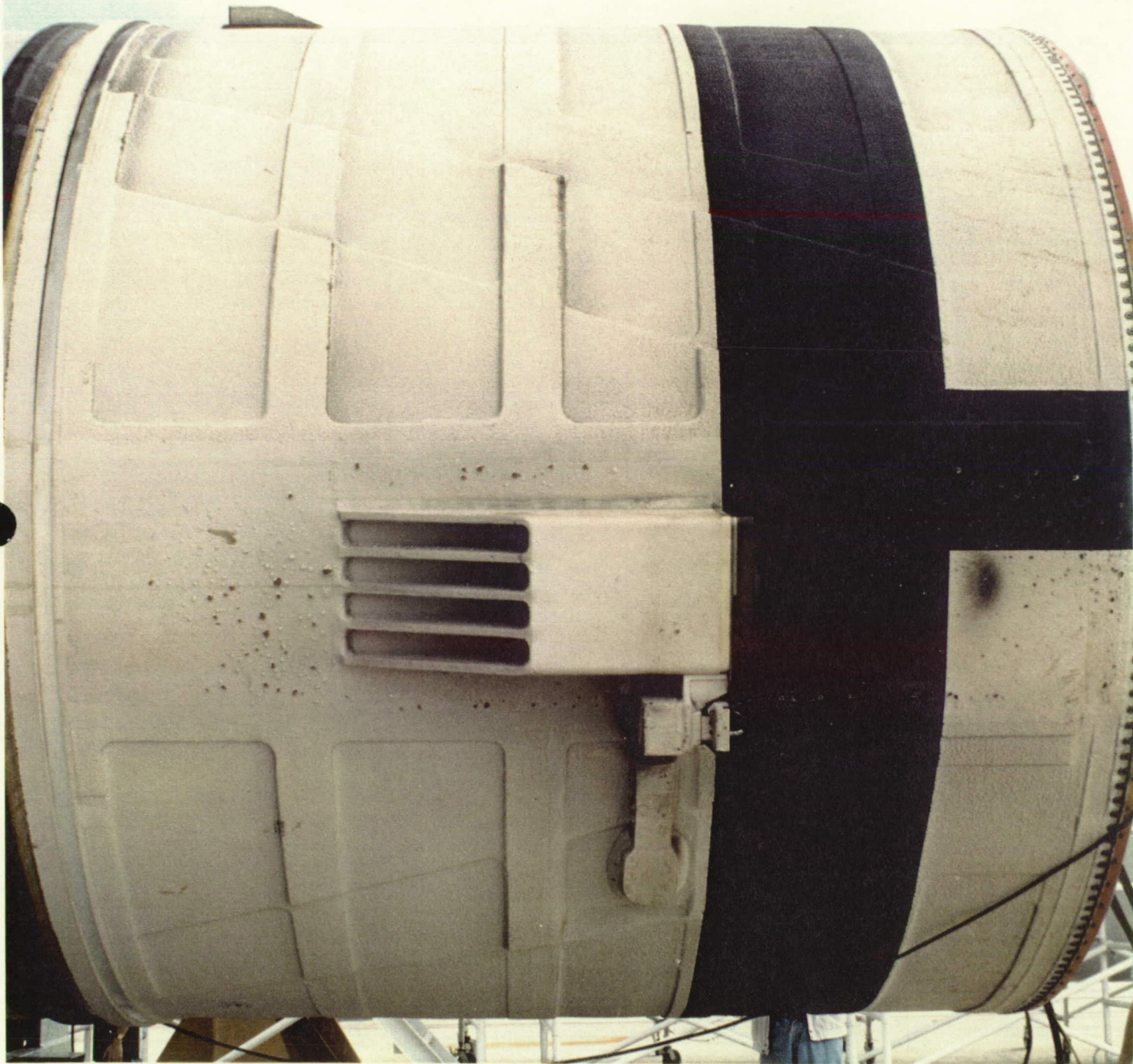

The LH forward skirt acreeage MSA-2 exhibited no debonds or missing TPS. Both RSS antenna covers/phenolic base plates were intact.

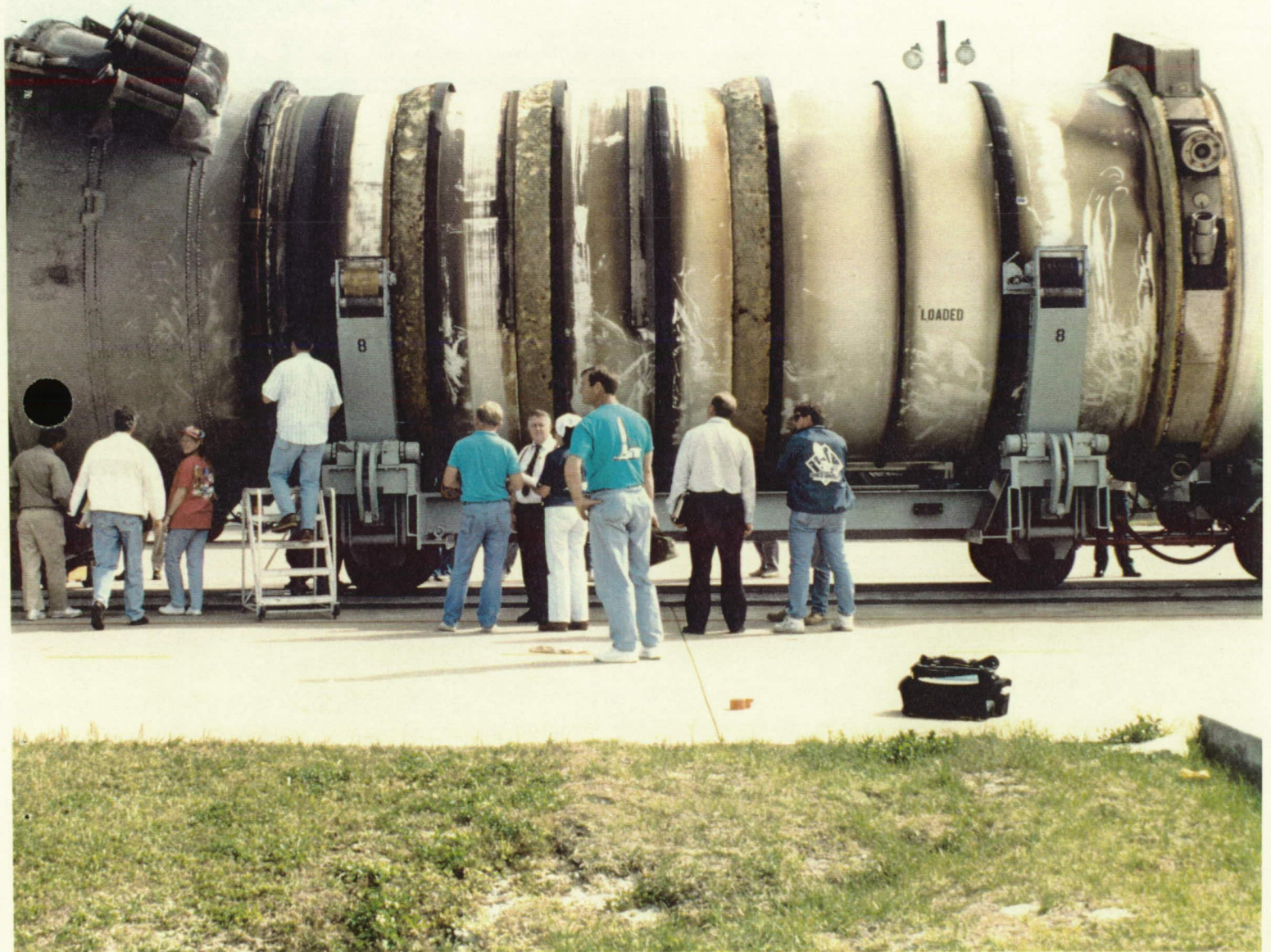

Post flight condition of the aft booster and aft skirt. The ET/SRB aft struts, ETA ring, IEA, IEA covers, and aft booster stiffener rings appeared undamaged.



Five areas of MSA-2, the largest of which measured 3" x 2.5", were missing from the aft skirt acraege MSA-2.



Two areas of MSA-2 were debonded on the aft skirt acreage

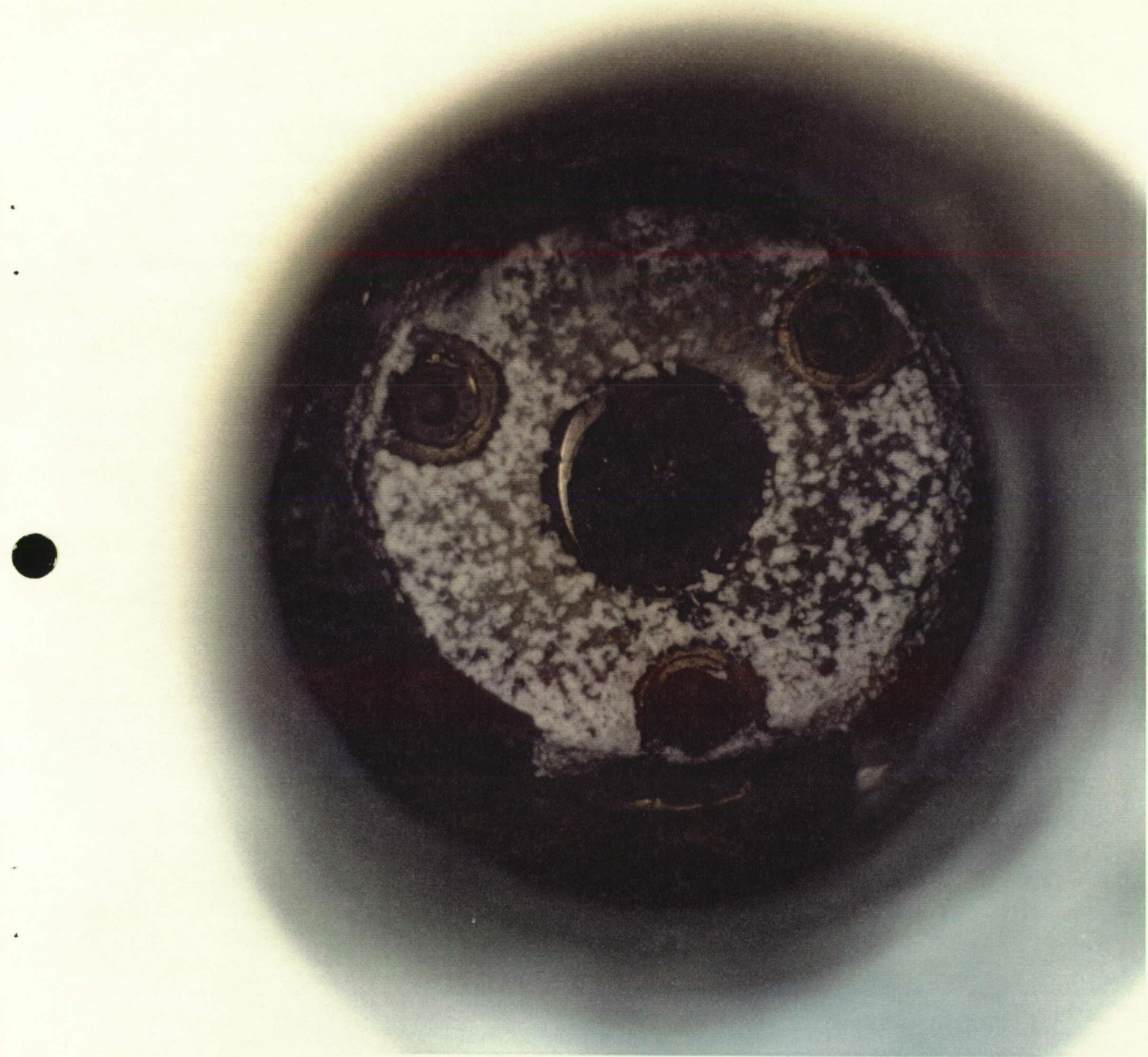

The HDP #5 Debris Containment System plunger was obstructed by frangible nut halves. The other three DCS plungers were properly seated.

7.3 RECOVERED SRB DISASSEMBLY FINDINGS

STS-55 was the fifteenth flight to utilize the new "optimized" frangible links in the holddown post DCS's. The link was designed to increase the DCS plunger velocity and improve the seating alignment while leaving the stud ejection velocity the same. The design was intended to prevent ordnance debris from falling out of the DCS yet not increase the likelihood of a stud hang-up. According to NSTS-07700, the Debris Containment System should retain a minimum of 90 percent of the ordnance debris.

A recent change to the disassembly procedures by SRB Project (DCN 009 10MNL-0035) eliminated the weighing of frangible nut pieces and ordnance fragments in the DCS containers unless: 1) debris is observed in the launch films; 2) the DCS plunger has an anomalous appearance during disassembly; or, 3) visual inspection of the expected DCS contents reveals the absence of any pieces.

An NSI detonator was wedged between the HDP #4 DCS plunger and the stud hole wall. The HDP #5 DCS plunger was obstructed by frangible nut halves. Due to these discrepancies, the contents of the DCS #4 and #5 housings were weighed. A total of 0.715 pounds of debris were lost (most likely at water impact) from the HDP #5 DCS.

HDP #	% of Nut without 2 Large Halves	% of Ordnance Fragments	% Overall
4	99	97	99
5	60	20	43

SRB Post Launch Anomalies are listed in Section 10.

8.0 ORBITER POST LANDING DEBRIS ASSESSMENT

A post landing debris inspection of OV-102 (Columbia) was conducted 6-7 May 1993 at the Ames-Dryden Flight Research Facility (ADFRF)/Edwards Air Force Base (EAFB) on Runway 22 and in the Mate-Demate Device (MDD). This inspection was performed to identify debris impact damage and, if possible, debris sources. The Orbiter TPS sustained a total of 143 hits, of which 13 had a major dimension of one inch or greater. This total does not include the numerous hits on the base heat shield attributed to SSME vibration/acoustics and exhaust plume recirculation. A comparison of these numbers to statistics from 39 previous missions of similar configuration (excluding missions STS-23, 24, 25, 26, 26R, 27R, 30R, and 42, which had damage from known debris sources), indicates that the total number of hits is near average and the number of hits one inch or larger is less than average (reference Figures 13-16).

The Orbiter lower surface sustained a total of 128 hits, of which 10 had a major dimension of one inch or greater. The majority of this damage occurred near the ET/ORB umbilicals. Seventy-four hits, including 2 greater than 1-inch, were clustered inboard and aft of the LH2 ET/ORB umbilical cavity. Similar clusters have been observed on previous flights and are attributed to impacts from the umbilical purge barrier and/or ice at ET separation.

The following table breaks down the STS-55 Orbiter debris damage by area:

	<u>HITS > 1"</u>	<u>TOTAL HITS</u>
Lower surface	10	128
Upper surface	0	6
Right side	1	1
Left side	1	3
Right OMS Pod	1	5
Left OMS Pod	0	0
TOTALS	13	143

No TPS damage was attributed to material from the wheels, tires, or brakes. The main landing gear tires were considered to be in excellent condition for a landing on a concrete runway. However, RH MLG inboard tire tread exhibited some localized separation from the casing.

The RH ET/ORB attach point (EO-3) hole plugger was obstructed by a frangible nut half (PR PYR2-15-0124). Two ordnance fragments (P/N SKD26100-099-409 and NBS-RF1-8) were found on the runway below the LO2 ET/ORB umbilical after the ET doors were opened. EO-1 and EO-2 ET/Orbiter separation devices appeared to have functioned properly. All ET/Orbiter umbilical separation ordnance retention shutters were closed properly.

STS-55

FIGURE 13. DEBRIS DAMAGE LOCATIONS

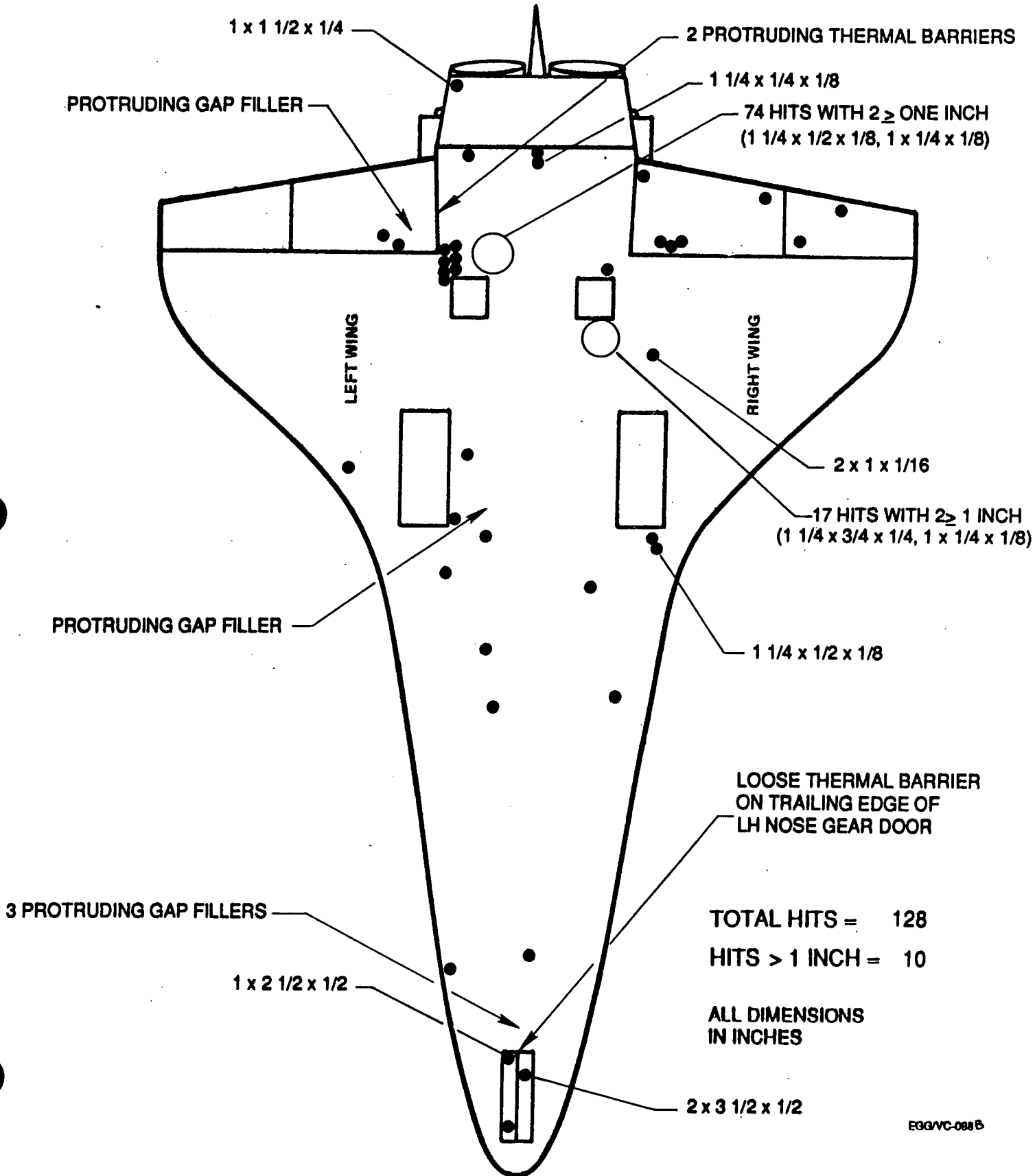

STS-55

FIGURE 14. DEBRIS DAMAGE LOCATIONS

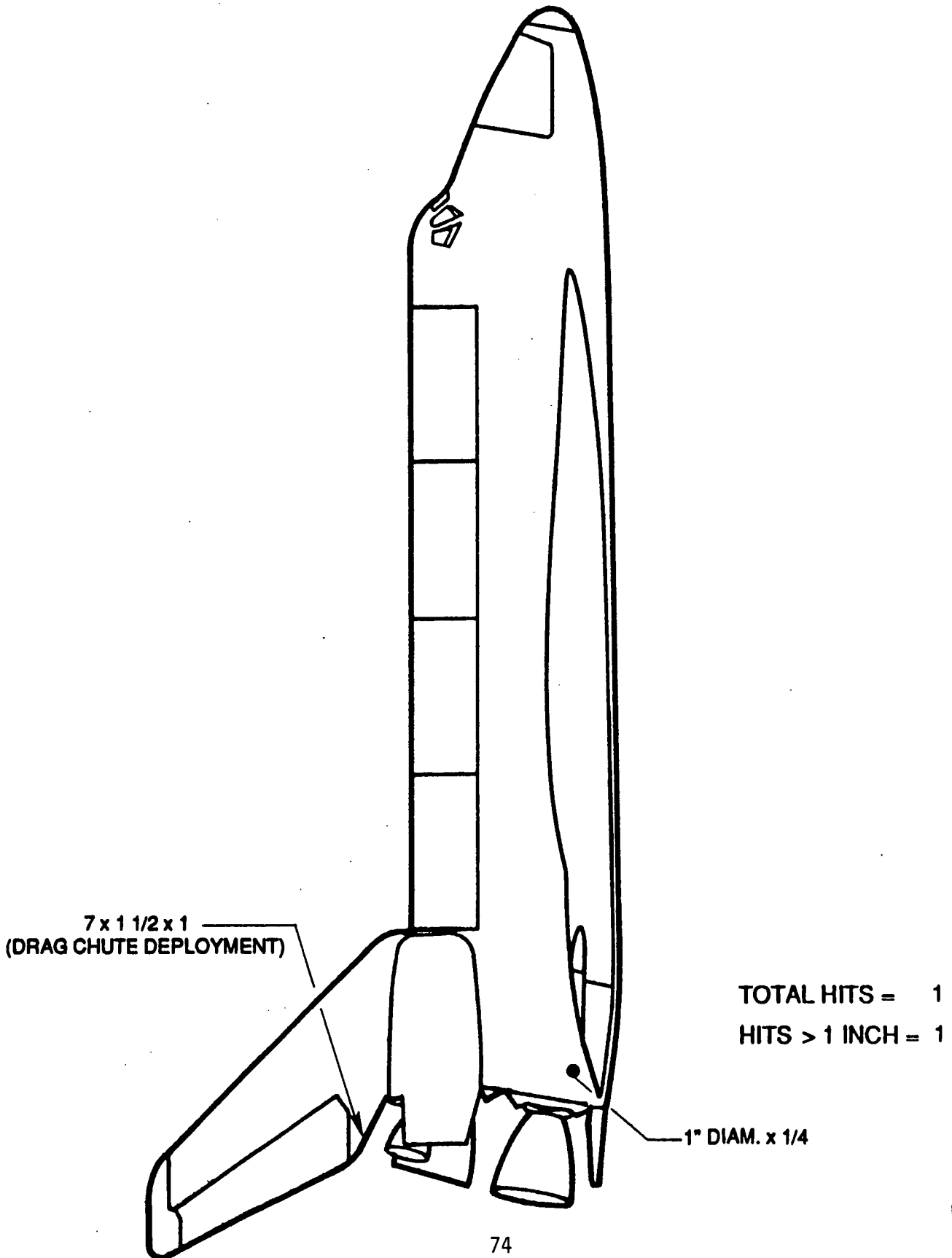

STS-55

FIGURE 15. **DEBRIS DAMAGE LOCATIONS**

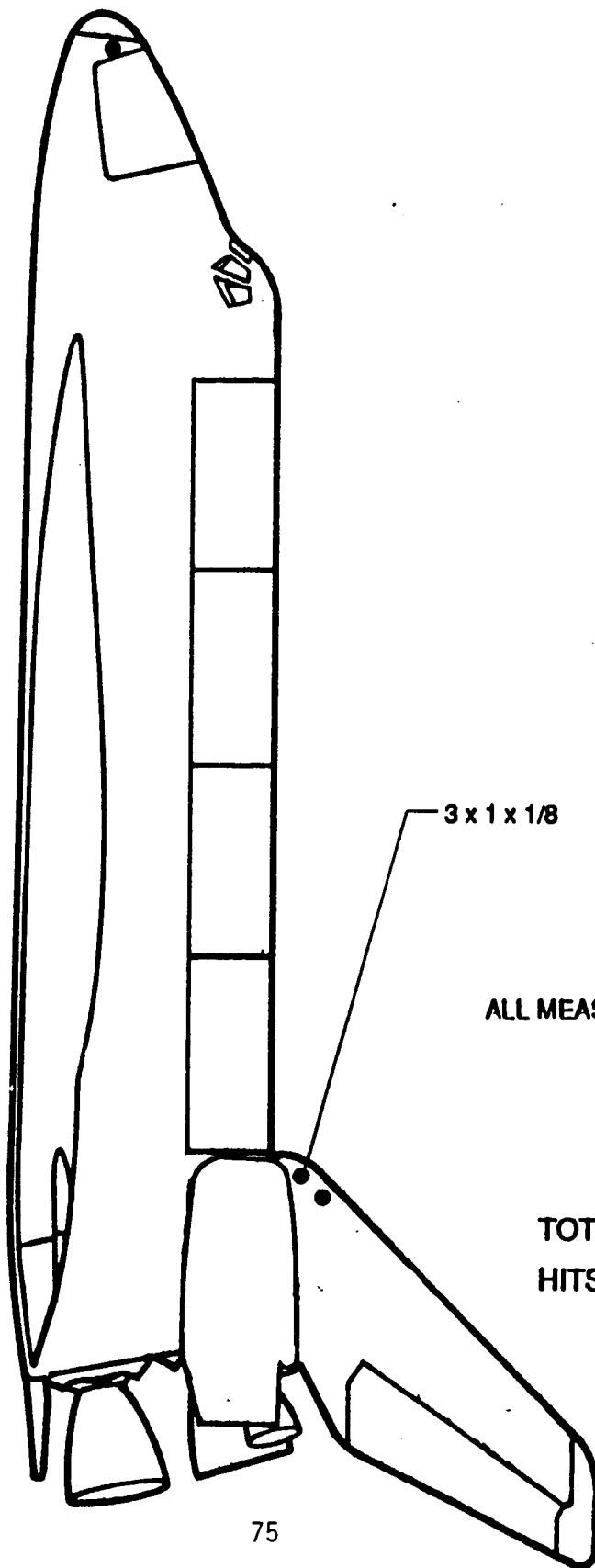

STS-55

FIGURE 16. **DEBRIS DAMAGE LOCATIONS**

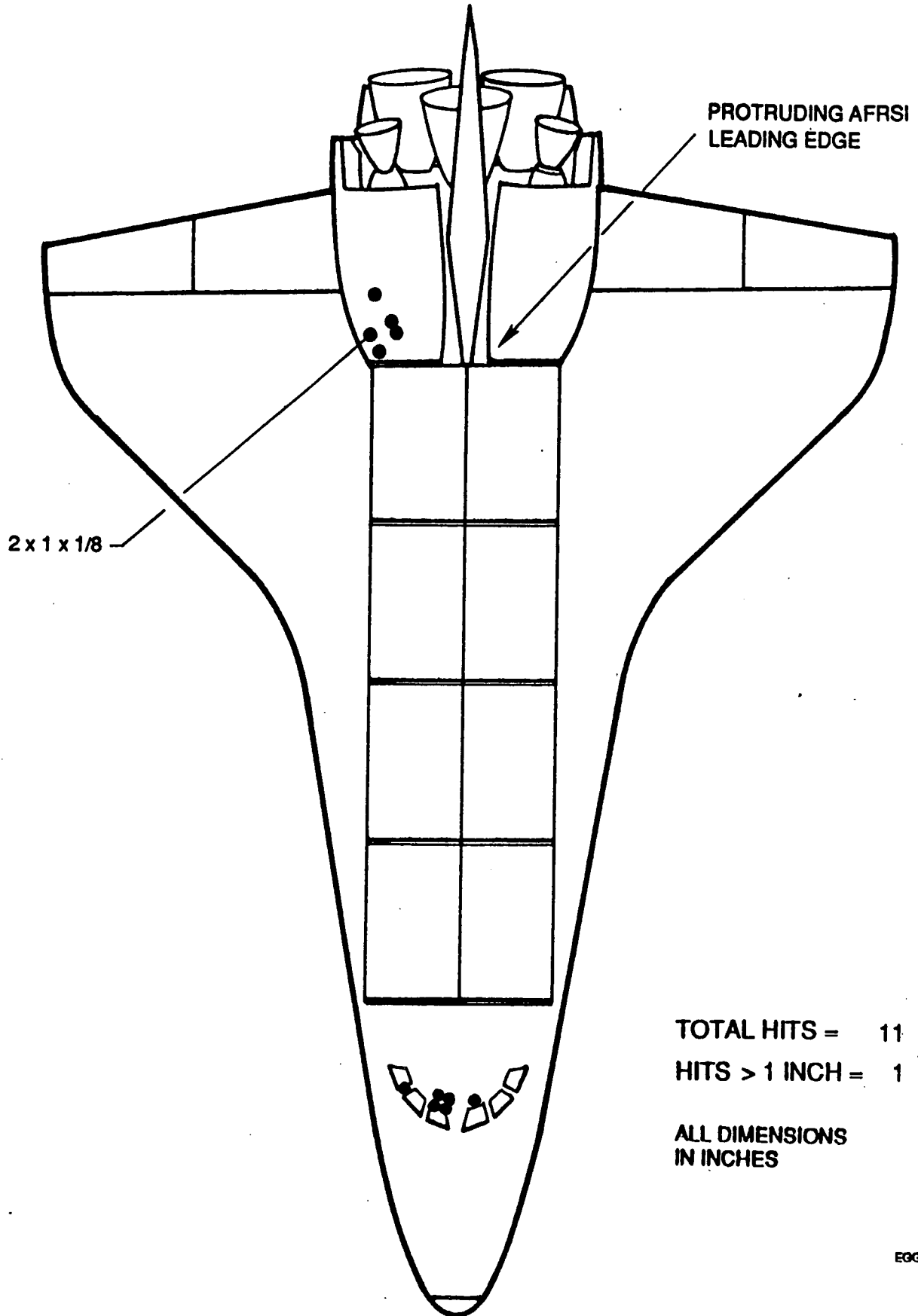

During separation of the External Tank from the Orbiter, an MPS sensor indicated the LH2 recirculation line valve may not have closed properly. Photography from the umbilical camera showed no anomalies on the ET side of the LH2 disconnect. Visual inspection of the Orbiter LH2 recirculation line interface after landing revealed the disconnect actuator (PD3) was in the open position (should have been closed). The disconnect flapper was in the proper position since it is spring loaded closed and cannot cycle without the ET disconnect in place. The seal plate behind the flapper exhibited some deformation. The disconnect will be replaced.

All Orbiter windows exhibited typical hazing with the greatest amount present on windows #3 and #4. Surface wipes were taken from windows #1-8 for laboratory analysis (Figure 17).

Tile damage on the base heat shield was less than usual. The SSME Dome Mounted Heat Shield (DMHS) closeout blanket sacrificial panels were intact and undamaged. A one-foot square oval shaped area of residue was present on the SSME #3 engine mounted heat shield (EMHS) at the 4:00 o'clock position. The tan colored residue was sampled for laboratory analysis (Figure 17).

Runway 22 had been swept/inspected by Air Force personnel on May 6, 1993, and all potentially damaging debris was removed. The post landing walkdown of Runway 22 was performed immediately after landing. No organic (bird) debris or non-flight hardware was found on the runway.

Eleven pieces of black tile were recovered in the approximate area of the drag chute deployment. These tile fragments originated from the rudder/speed brake "stinger", which is an area damaged on previous uses of the drag chute by contact with the parachute riser lines. This flight marked the eighth use of the Orbiter drag chute. Aside from the damage to the vertical stabilizer stinger, the drag chute appeared to have functioned nominally. All drag chute hardware was recovered and appeared to be in good condition.

A portable Minolta/Land Cyclops infrared spot radiometer was used to measure the surface temperatures of three areas on the Orbiter (per OMRSD V09AJ0.095). Twenty-two minutes after landing, the Orbiter nose cap RCC was 160 degrees Fahrenheit. Fifty-two minutes after landing, the RH wing leading edge RCC panel #9 was 78 degrees F and panel #17 was 82 degrees F. (Figure 18).

In summary, the total number of Orbiter TPS debris hits was near average and the number of hits one inch or larger was less than average when compared to previous missions (Figures 19-20).

Orbiter Post Launch Anomalies are listed in Section 10.

STS-55

FIGURE 17. **CHEMICAL SAMPLE LOCATIONS**

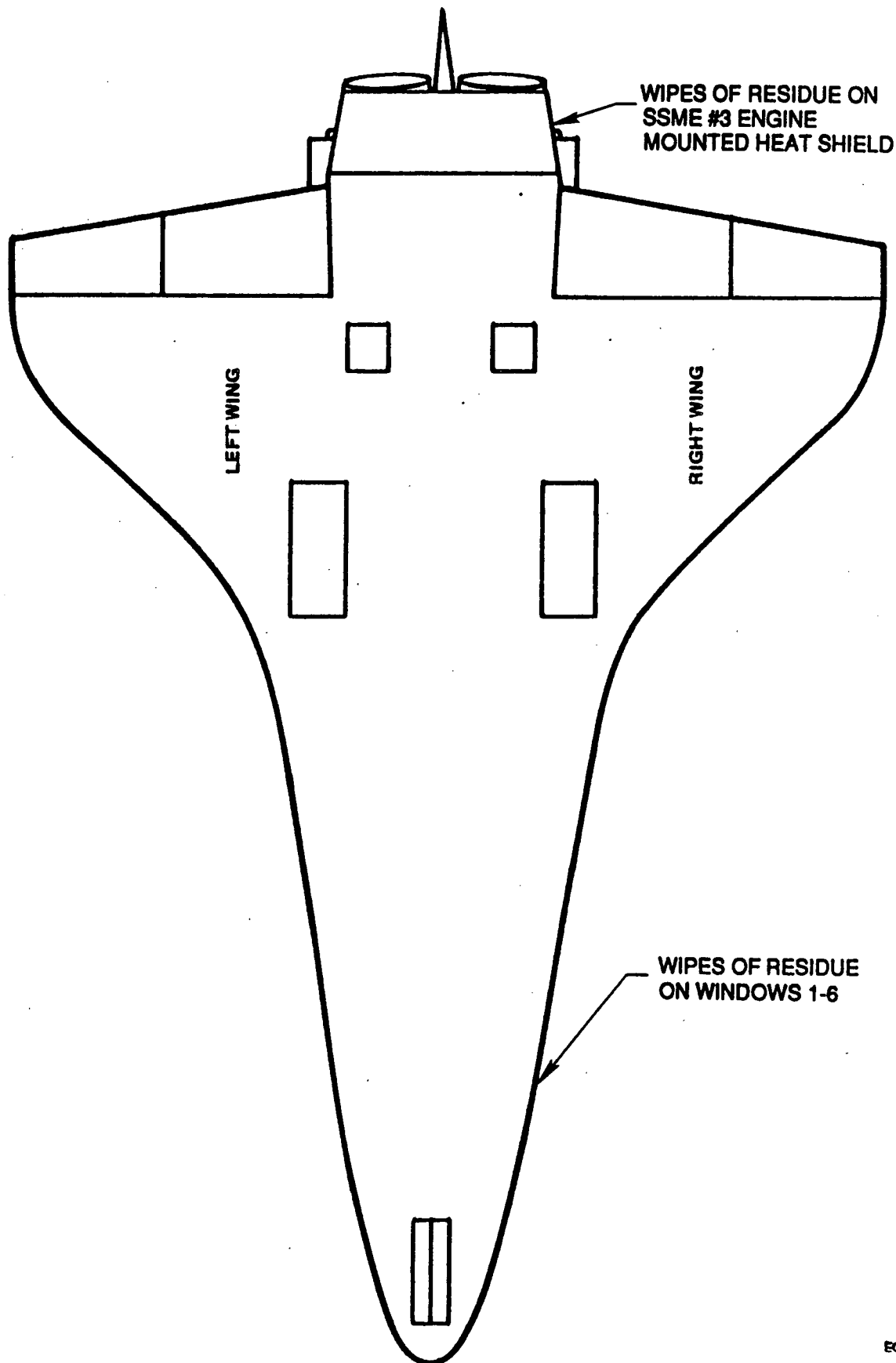

FIGURE 18. STS-55 RCC TEMPERATURE MEASUREMENTS AS RECORDED BY THE SHUTTLE THERMAL IMAGER TEMPERATURE MEASUREMENTS

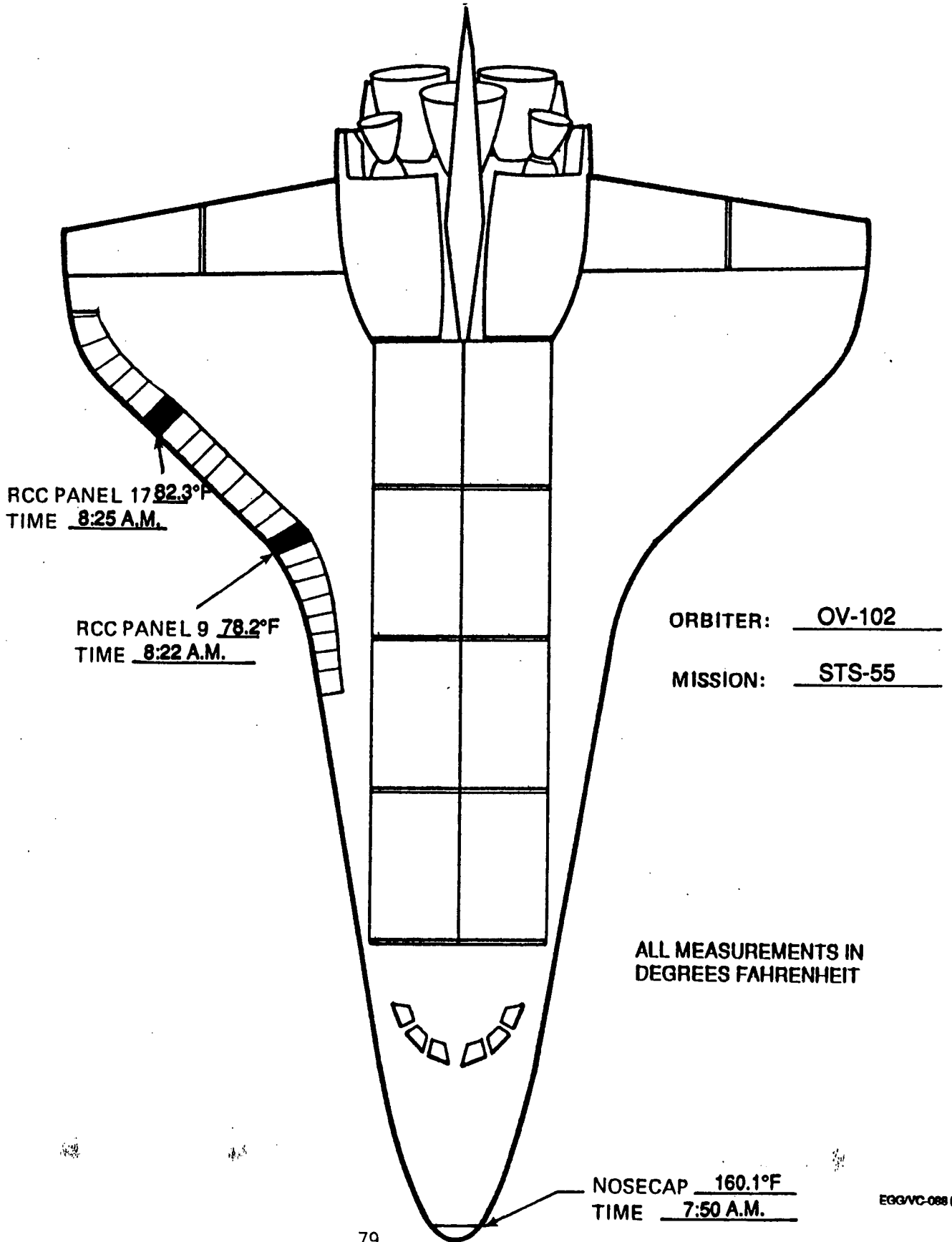

FIGURE 19: ORBITER POST FLIGHT DEBRIS DAMAGE SUMMARY

	LOWER SURFACE		ENTIRE VEHICLE	
	HITS > 1 INCH	TOTAL HITS	HITS > 1 INCH	TOTAL HITS
STS-6	15	80	36	120
STS-8	3	29	7	56
STS-9 (41-A)	9	49	14	58
STS-11 (41-B)	11	19	34	63
STS-13 (41-C)	5	27	8	36
STS-14 (41-D)	10	44	30	111
STS-17 (41-G)	25	69	36	154
STS-19 (51-A)	14	66	20	87
STS-20 (51-C)	24	67	28	81
STS-27 (51-I)	21	96	33	141
STS-28 (51-J)	7	66	17	111
STS-30 (61-A)	24	129	34	183
STS-31 (61-B)	37	177	55	257
STS-32 (61-C)	20	134	39	193
STS-29	18	100	23	132
STS-28R	13	60	20	76
STS-34	17	51	18	53
STS-33R	21	107	21	118
STS-32R	13	111	15	120
STS-36	17	61	19	81
STS-31R	13	47	14	63
STS-41	13	64	16	76
STS-38	7	70	8	81
STS-35	15	132	17	147
STS-37	7	91	10	113
STS-39	14	217	16	238
STS-40	23	153	25	197
STS-43	24	122	25	131
STS-48	14	100	25	182
STS-44	6	74	9	101
STS-45	18	122	22	172
STS-49	6	55	11	114
STS-50	28	141	45	184
STS-46	11	186	22	236
STS-47	3	48	11	108
STS-52	6	152	16	290
STS-53	11	145	23	240
STS-54	14	80	14	131
STS-56	18	94	36	156
AVERAGE	14.7	93.2	22.4	133.1
SIGMA	7.4	46.0	10.9	61.8
STS-55	10	128	13	143

MISSIONS STS-23, 24, 25, 26, 26R, 27R, 30R, AND 42 ARE NOT INCLUDED IN THIS ANALYSIS SINCE THESE MISSIONS HAD SIGNIFICANT DAMAGE CAUSED BY KNOWN DEBRIS SOURCES

COMPARISON TABLE

FIGURE 20.

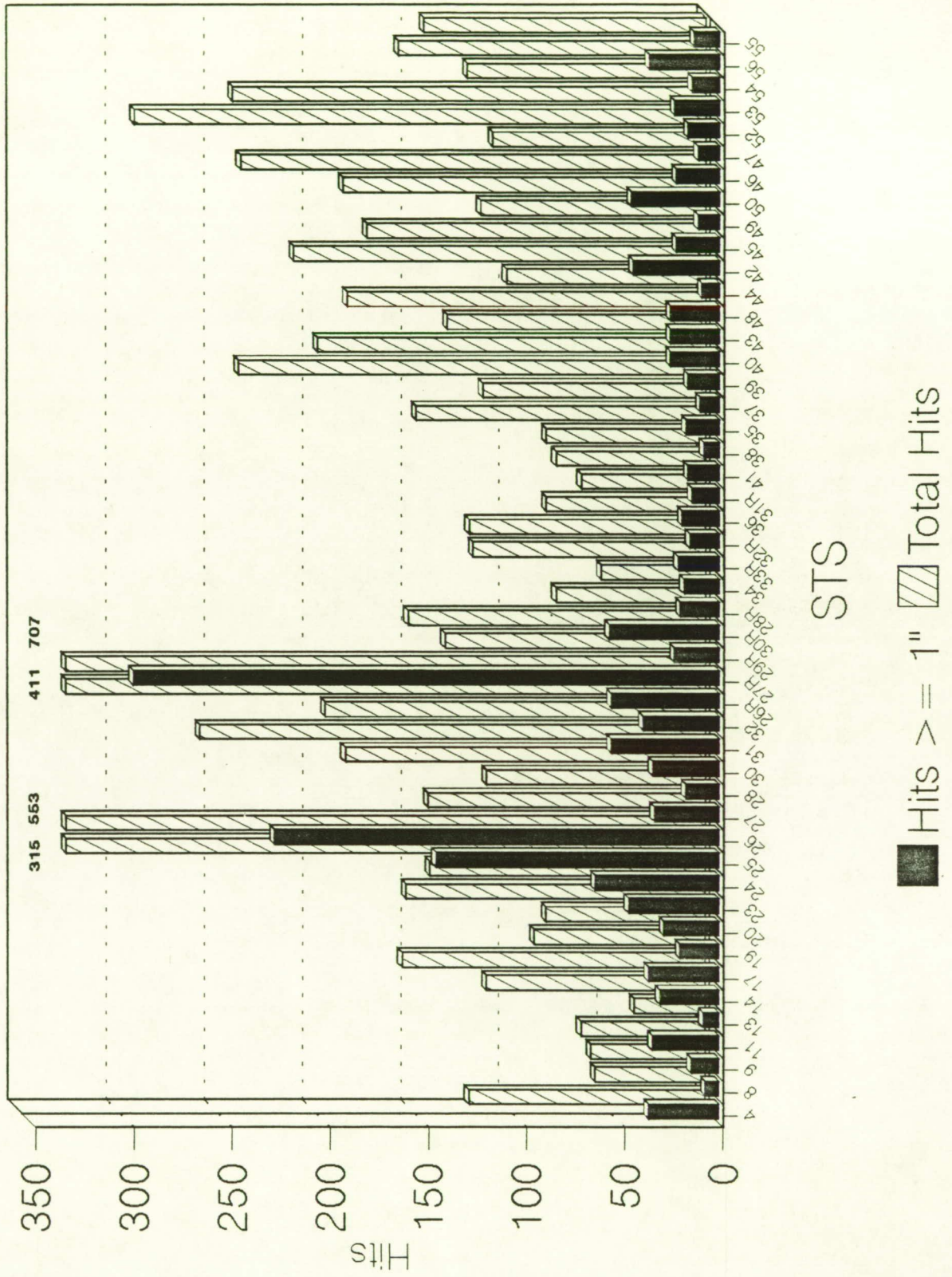



The Orbiter lower surface sustained a total of 128 hits. The majority of this damage occurred in a cluster near the ET/ORB LH2 umbilical. Similar clusters have been observed on previous flights and are attributed to impacts from the umbilical purge barrier and/or ice during ascent.

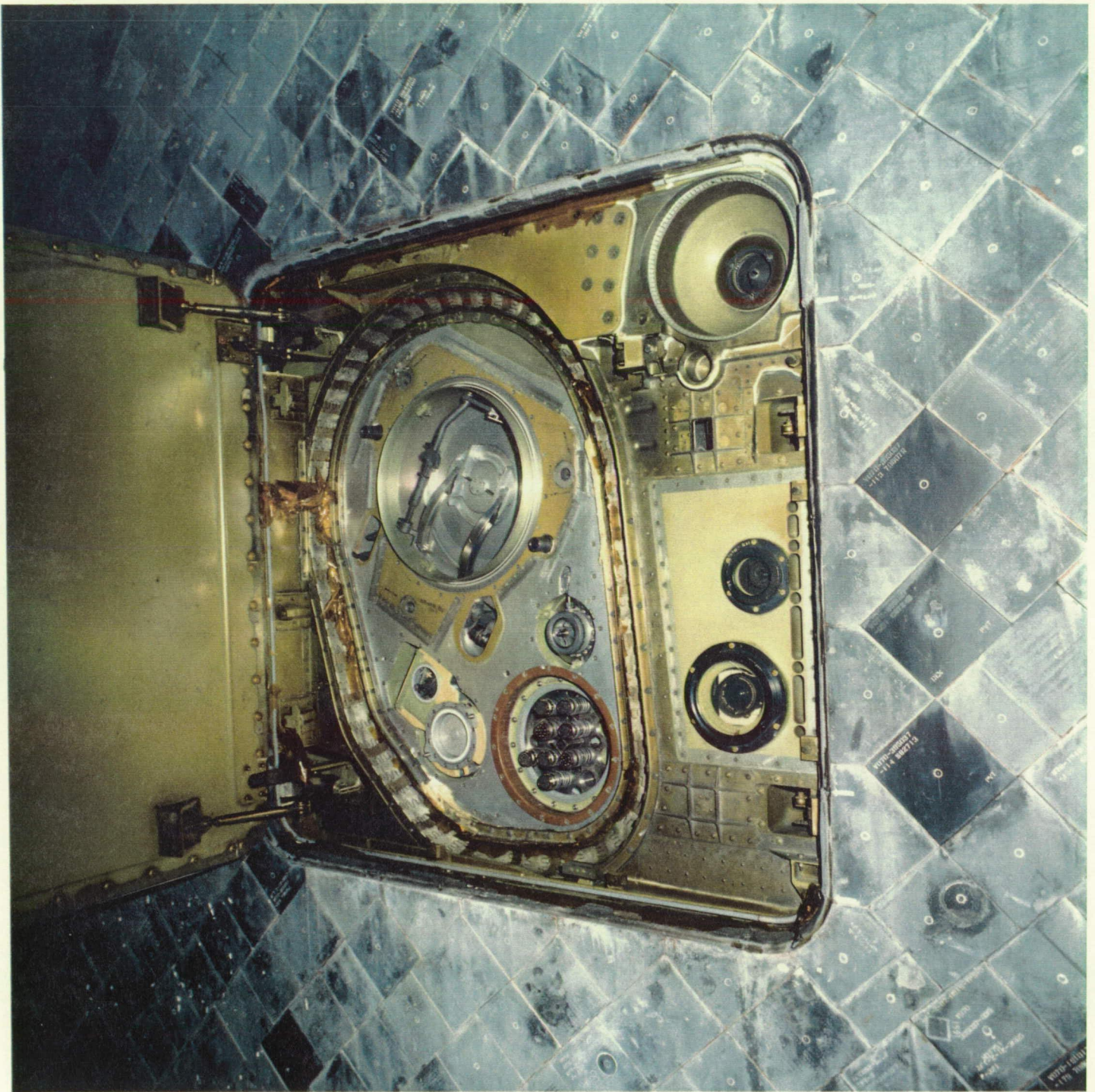

Overall view of the LH2 ET/ORB umbilical. All separation ordnance devices functioned properly. No flight hardware was found on the runway below the umbilical when the ET door was opened.

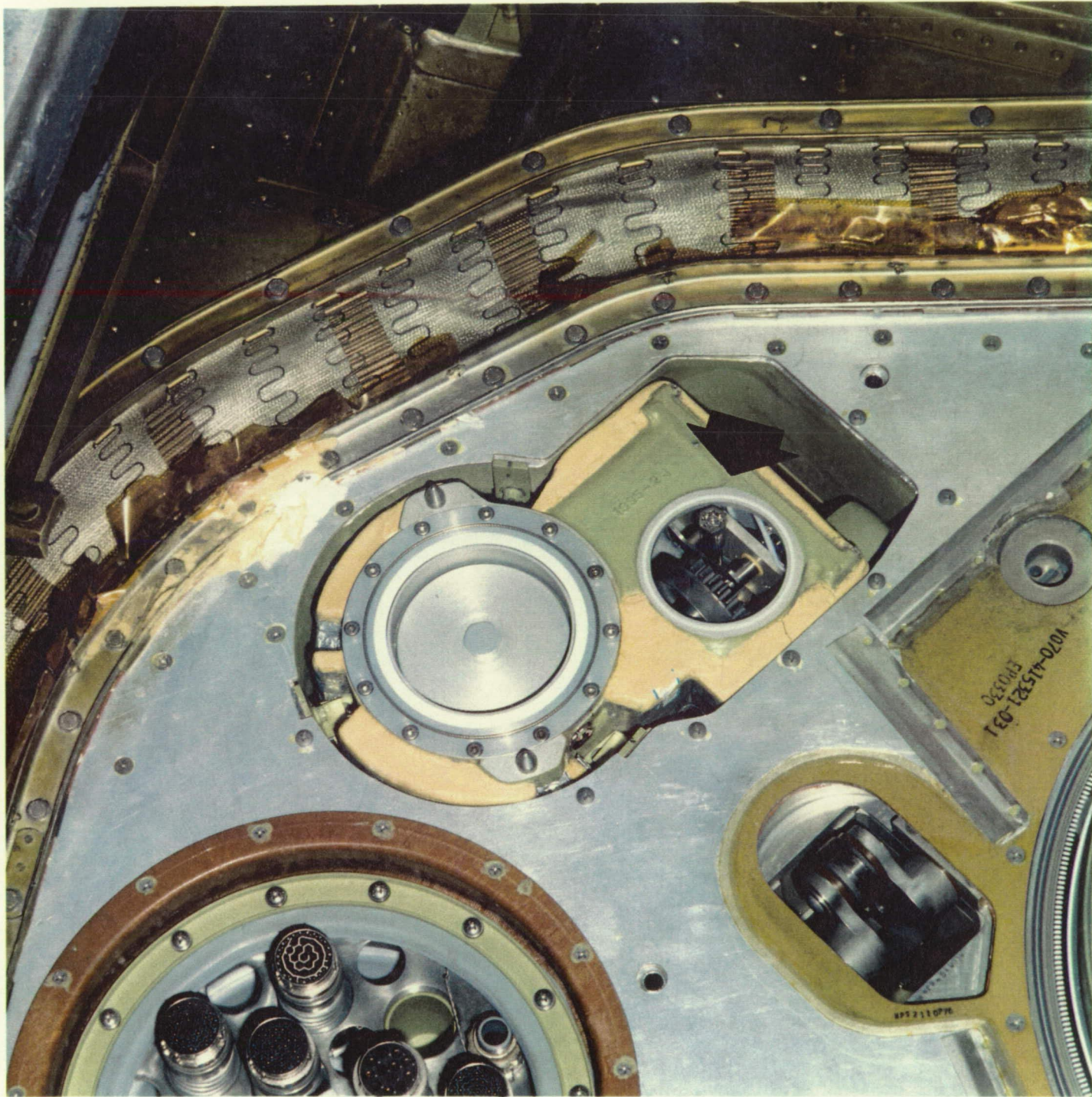

Visual inspection of the LH2 4-inch line interface revealed the rack (arrow) was extended and protruding beyond the nominal mold line. The seal plate behind the flapper exhibited some deformation.



Overall view of the LO2 ET/ORB umbilical.



The right ET/ORB attach point (EO-3) hole plugger had not seated and was obstructed by a frangible nut half



Two ordnance fragments were found on the runway below the
L02 ET/ORB umbilical after the ET doors were opened



All Orbiter windows exhibited typical hazing with the greatest amount present on windows #3 and #4

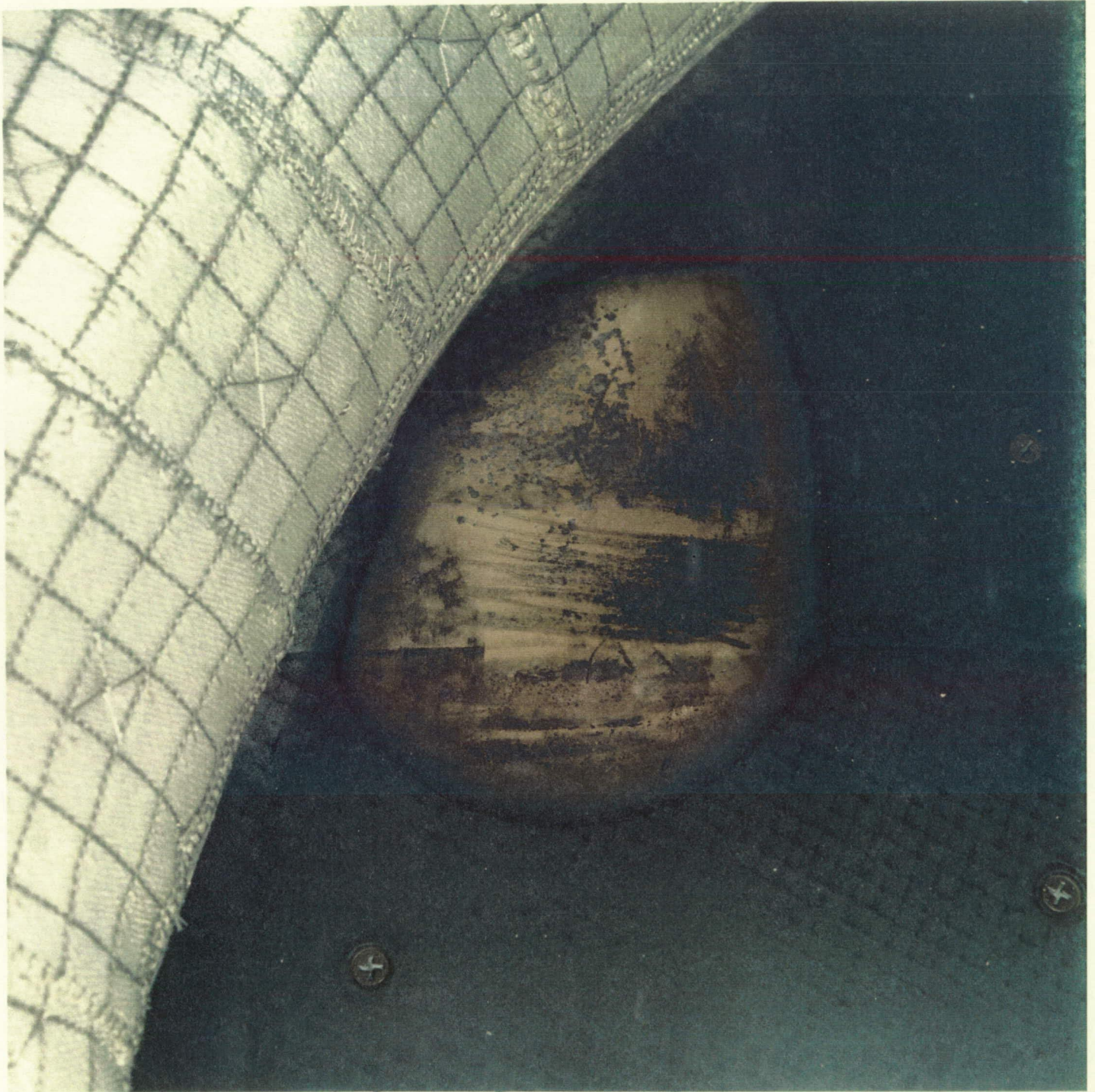

A 1-foot square oval-shaped area of residue was present on the SSME #3 engine mounted heat shield at the 4:00 o'clock position

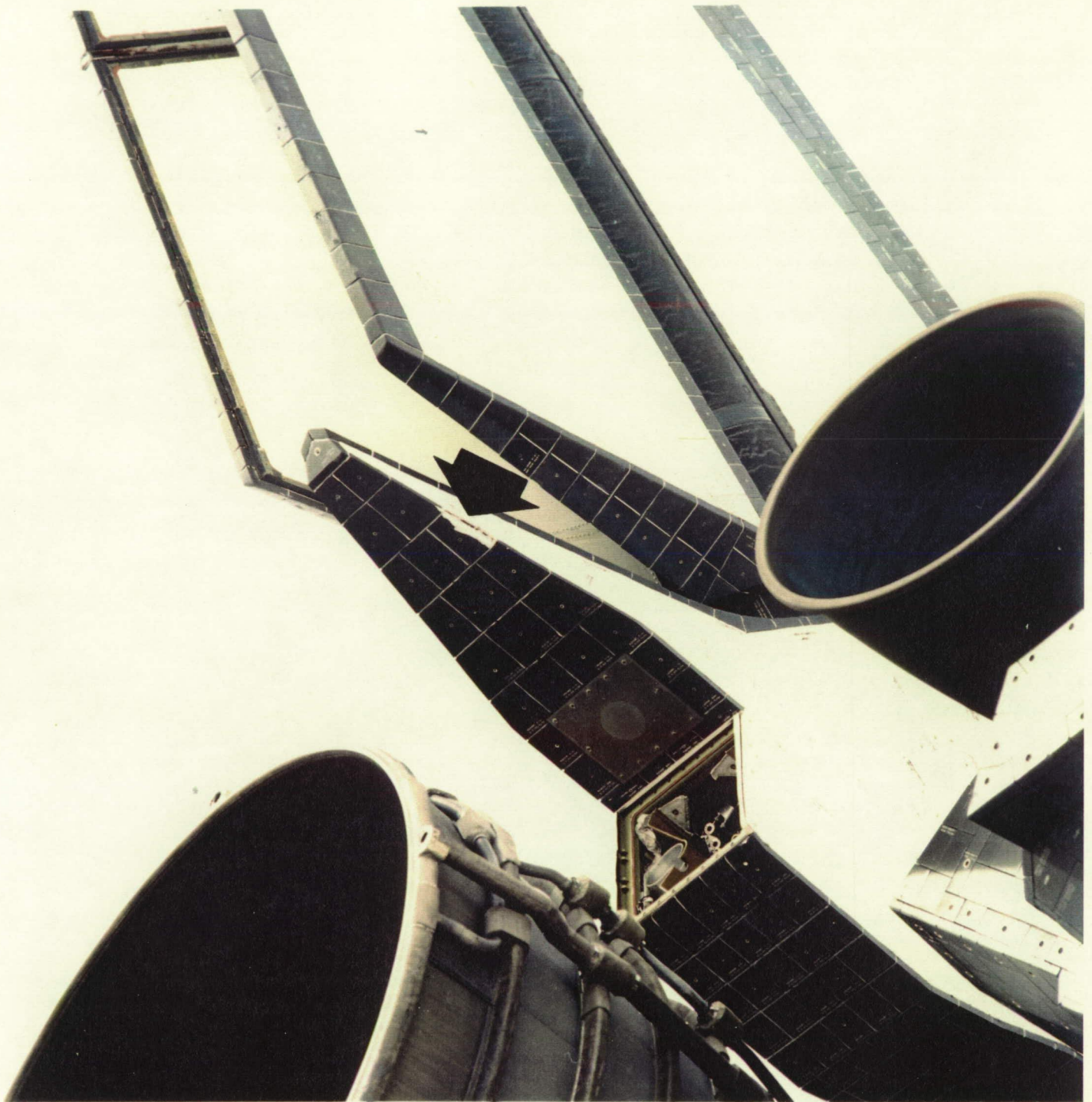

Eleven black tile fragments were found on the runway in the general area of drag chute deployment. The tile pieces originated from the vertical stabilizer "stinger", which is an area damaged on previous uses of the drag chute by contact with the parachute riser lines.

9.0 DEBRIS SAMPLE LAB REPORTS

A total of eight samples were obtained from OV-102 Columbia during the STS-55 post landing debris assessment at Dryden Flight Research Facility DFRF-EAFB (reference Figure 17). The submitted samples consisted of 8 window wipes (Windows 1-8). The samples were analyzed by the NASA KSC Microchemical Analysis Branch (MAB) for material composition and comparison to known STS materials. Debris analysis involves the placing and correlating of particles and residues with respect to composition, thermal (mission) effects, and availability. Debris sample results and analyses are listed by Orbiter location in the following summaries.

Orbiter Windows

Samples from the Orbiter windows indicated exposure to SRB BSM exhaust, Orbiter Thermal Protection System (TPS), paints and primer from various sources, landing site products, and organic materials. A finding that has been previously observed (STS-50 vertical stabilizer sample, STS-56 window samples) was the presence of "E-glass" (2 samples). Another previously observed finding (STS-53 windows) was the absence of metallics from certain window samples - windows 2 and 4 for this sample set. Trace amounts of yellow paint were found in seven of the eight window samples and was attributed to facility/ground support equipment paint. Results of the organic material analysis are still pending. There was no apparent vehicle damage related to these residual findings.

STS-56 Organic Analysis

The final results of the STS-56 organic analysis are also shown in this report. Types of materials identified included those associated with window covers (plastic polymers, filled plastic PVC), RTV, and cellulosic (sample cloth). This variety of residuals, which were attributed to known sources, did not change significantly when compared to previous sample data (reference Figure 21). No new findings were found in this analysis.

New Findings

This sampling set provided one new finding in debris residual post-flight samples. This new finding was obtained from the window samples and did not appear related to any debris damage problem. A clear calcium-sulfur rich material was detected and is believed to originate from the landing site as possibly anhydrite, a material common to DFRF soil.

STS	Sample Location			
	Windows	Wing RCC	Lower Tile Surface	Other
55	<p>Metallics - BSM Residue (SRB) RTV, Tile (ORB TPS) Insulation Glass (ORB TPS) Glass fiber - 'E-glass' Calcite, Muscovite, Salt (Landing Site) Anhydrite (Landing Site) Paint Organics</p>			
56	<p>Metallics - BSM Residue (SRB) - Solder (Launch Site) RTV, Tile, Tile coating (ORB TPS) Insulation Glass (ORB TPS) Glass fiber 'E-glass' Organics-Plastic polymer, filled plastic (PVC) Paint</p>		<p>Silica-rich tile (ORB TPS) Tile coating, RTV (ORB TPS)</p>	
54	<p>Metallics - BSM Residue (SRB) RTV, Tile (ORB TPS) Insulation Glass (ORB TPS) Calcite, Alpha-Quartz, Salt (Landing Site) Organics - plastic (Iocite) Organics - Plastic polymer, filled plastic (PVC) Paint</p>	<p>Metallics - BSM Residue (SRB) Tile, Insulation Glass (ORB TPS) Calcium - Silica, Salt (Landing Site) Organics - plastic polymers Paint</p>		
53	<p>Metallics - BSM Residue (SRB) - Solder (Launch Site) RTV, Tile (ORB TPS) Insulation Glass (ORB TPS) Calcite, Salt (Landing Site) Organics - Fibrous mat'l, RTV, Grease Organics-filled rubber, plastic polymers Paint</p>		<p>LO2 Umbilical Door - - Closeout Mat'l (ORB TPS) - Hydrocarbon "grease-like" sub.</p>	<p>RH SRB Alt Skirt Damage site - - Tile, Tile coating mat'l (ORB TPS)</p>
52	<p>Metallics - BSM Residue (SRB) RTV, Tile (ORB TPS) Insulation Glass (ORB TPS) Calcite, Salt (Landing Site) Organics-Fibrous mat'l, red RTV Organics-filled rubber, plastic polymers Paint</p>			<p>HRSI Tile Damage Site - - Tile Mat'l and silicon carbide (ORB TPS) - Paints - Calcite, salts (Landing Site)</p>
47	<p>Metallics - BSM Residue (SRB) RTV, Tile (ORB TPS) Insulation Glass (ORB TPS) Calcite, Salt (Landing Site) Window Polish Residue (ORB) Organics-Fibrous mat'l, red RTV Organics-filled rubber, plastic polymers Paint</p>		<p>Silica-rich Tile (ORB TPS)</p>	

FIGURE 21. Orbiter Post Landing Microchemical Sample Results

STS	Sample Location			
	Windows	Wing RCC	Lower Tile Surface	Umbilical
46	Metallics - BSM Residue (SRB) RTV, Tile (ORB TPS) Insulation Glass (ORB TPS) Calcite, Alpha-Quartz, Salt (Landing Site) Organics-Adhesive, Foam, red RTV Organics-filled rubber, plastic polymers Paint			Crew Hatch Window - Metallics - BSM Residue (SRB) - Alpha-Quartz, Salt (Landing Site) - RTV, Tile (ORB TPS) - Paint - Organics
50	Metallics - BSM Residue (SRB) RTV, Tile (ORB TPS) Insulation Glass (ORB TPS) Window Polish Residue (ORB) Mica, Calcium, Salt (Landing Site) Organics-Adhesive, Foam Organics-Plastic Polymers Paint		Silica-Rich Tile (ORB TPS)	Orbiter Vertical Stabilizer - Tile Coating (ORB TPS) - Structural Coating Glass "E-Glass"
49	Metallics - BSM Residue (SRB) RTV, Tile (ORB TPS) Insulation Glass (ORB TPS) Mica, Calcium, Salt (Landing Site) Organics Paint	RTV, Tile (ORB TPS) Rust - BSM Residue (SRB) Muscovite, Salt (Landing Site) Organics Paint	RTV, Tile (ORB TPS) Insulation Glass (ORB TPS) Rust - BSM Residue (SRB) Calcium Matl, Salt (Landing Site Soil) Organics Paint	
45	Metallics - BSM Residue (SRB) RTV, Tile (ORB TPS) Insulation Glass (ORB TPS) Calcite, Salt (Landing Site) Window Polish Residue (ORB) Organics Paint		Iron - Rich Matl Paint	
42	Metallics - BSM Residue (SRB) RTV, Tile (ORB TPS) Insulation Glass (ORB TPS) Calcite, Salt (Landing Site) Muscovite (Landing Site) Organics Paint		Metallics - BSM Residue (SRB) Tile, Tile Coating (ORB) Salt (Landing Site) Paint	Organics RH Fuselage - Tile Coating (ORB)
44	Metallics - BSM Residue (SRB) RTV, Tile (ORB TPS) Insulation Glass (ORB TPS) Calcite, Salt (Landing Site) Muscovite (Landing Site) Organics Paint			Organics Silica-Magnesium Matl

FIGURE 21. Orbiter Post Landing Microchemical Sample Results

STS	Sample Location			
	Windows	Wing RCC	Lower Tile Surface	Umbilical
48	Metallics - BSM Residue (SRB) RTV, Tile (ORB TPS) Insulation Glass (ORB TPS) Calcite, Salt (Landing Site) Muscovite (Landing Site) Organics Paint			Metallics Silica - Rich Mat'l (Landing Site) Orb Umbilical CO Mat'l (ORB) Paints
43	Metallics - BSM Residue (SRB) RTV, Tile (ORB TPS) Insulation Glass (ORB TPS) Calcite, Salt (Landing Site) Window Polish Residue (ORB) Organics Paint		RTV, Tile (ORB TPS) Metallics - BSM Residue (SRB) Salt (Landing Site) Organics Paint	Runway - FFSI Coating (ORB)
40	Metallics - BSM Residue (SRB) RTV, Tile (ORB TPS) Insulation Glass (ORB TPS) Calcite, Salt (Landing Site) Window Polish Residue (ORB) Organics Paint	Metallics - BSM Residue (SRB) RTV, Tile (ORB) Insulation Glass (ORB TPS) Emsolite Foam (RCC Prot. Covers) Organics Paint	RTV, Tile (ORB TPS)	Metallics - BSM Residue (SRB) RTV, Tile (ORB TPS) Insulation Glass (ORB TPS) Organics (ORB Umb CO) Paint
39		Metallics - BSM Residue (SRB) RTV, Tile (ORB) Insulation Glass (ORB TPS) Emsolite Foam (RCC Prot. Covers) Organics Paint Hypalon Paint (SRB)	Tile (ORB TPS) Insulation Glass (ORB TPS)	
37	Metallics - BSM Residue (SRB) RTV, Tile (ORB TPS) Insulation Glass (ORB TPS) Calcite, Salt (Landing Site) Organics Paint	Metallics - BSM Residue (SRB) RTV, Tile (ORB) Insulation Glass (ORB TPS) Calcite, Salt (Landing Site) Organics Paint	RTV, Tile (ORB TPS) Insulation Glass (ORB TPS) Metallics - BSM Residue (SRB) Calcite, Salt (Landing Site) Organics	
35	Metallics - BSM Residue (SRB) RTV, Tile (ORB TPS) Insulation Glass (ORB TPS) Calcite, Salt (Landing Site) Window Polish Residue (ORB) Organics Paint	Metallics - BSM Residue (SRB) RTV, Tile (ORB) Organics	RTV, Tile (ORB TPS) Metallic - Rust, Aluminum Welding Slag (Facility)	
38		RTV, Tile (ORB TPS) Hypalon Paint (SRB) Emsolite Foam (RCC Prot. Cover)	Tile (ORB TPS)	

FIGURE 21. Orbiter Post Landing Microchemical Sample Results

STS	Sample Location				Other
	Windows	Wing RCC	Lower Tile Surface	Umbilical	
41	Metallics - BSM Residue (SRB) RTV, Tile (ORB TPS) Insulation Glass (ORB TPS) Calcite, Salt (Landing Site) Organics	Tile (ORB TPS) Salt (Landing Site)	Tile (ORB TPS)	Calcite (Landing Site) Fluorocarbon (Viton-ORB Umb) Foam (ORB C/O)	Fwd FRSI - Silicon Mat1 (ORB TPS)
31R	Metallics - BSM Residue (SRB) RTV, Tile (ORB TPS) Insulation Glass (ORB TPS) Calcite, Salt (Landing Site) Organics	Metallics - BSM Residue (SRB) RTV, Tile (ORB TPS) Insulation Glass (ORB TPS) Mica (Landing Site) Organics Foam Insulation (ET/SRB) Paint	RTV, Tile (ORB TPS) Insulation Glass (ORB TPS) Mica (Landing Site) Paint		
36	Metallics - BSM Residue (SRB) RTV, Tile (ORB TPS) Insulation Glass (ORB TPS) Mica, Salt (Landing Site) Paint	Rust - BSM Residue (SRB) Tile (ORB TPS) Paint Organics	RTV, Tile (ORB TPS) Insulation Glass (ORB TPS) Mica (Landing Site) Organics Microballoon (ET/SRB)	Rust - BSM Residue (SRB) RTV, Insulation Glass (ORB TPS) Microballoon (ET/SRB) Calcite (Landing Site) Foam, Organics (ORB Umb C/O)	
32R	Metallics - BSM Residue (SRB) RTV, Tile (ORB TPS) Insulation Glass (ORB TPS) Mica, Salt (Landing Site) Paint	Metallics - BSM Residue (SRB) Tile (ORB TPS) Carbon Fibers Titanium	Metallics - BSM Residue (SRB) Tile (ORB TPS) Carbon Fibers Titanium	Metallics - BSM Residue (SRB) RTV, Insulation Glass (ORB TPS) Phenolic Microballoon (ET/SRB) Quartz, Calcite (Landing Site) Organics	
33R	Metallics - BSM Residue (SRB) RTV, Tile (ORB TPS) Insulation Glass (ORB TPS) Micaeous Mat1, Salt (Landing Site) Window Polish Residue (ORB) Paint	Metallics - BSM Residue (SRB) Tile (ORB TPS) Insulation Glass (ORB TPS) Mica, Spar, Salt (Landing Site) Organics	RTV, Tile (ORB TPS)	Rust - BSM Residue (SRB) RTV, Insulation Glass (ORB TPS) Phenolic Microballoon (ET/SRB) Paint Organics	Crew Hatch Window - Rust - BSM Residue (SRB) - Alpha Quartz (TPS/Landing Site) - Paint - Organics
34	Metallics - BSM Residue (SRB) RTV, Tile (ORB TPS) Insulation Glass (ORB TPS) Alpha-Quartz, Silicates, Salt (L/S) Window Polish Residue (ORB)	Metallics - BSM Residue (SRB) RTV, Tile (ORB TPS) Insulation Glass (ORB TPS) Paint	RTV, Tile (ORB TPS) Stainless Steel Washer	RTV (ORB) Foam (ORB) Viton Rubber (ORB) Metallics - BSM Residue (SRB) Phenolic Microballoon (ET/SRB) Silicates, Calcium (Landing Site) Paint	
28R	Silicone (ORB FRCS Cover Adhesive)	Silicates (Landing Site) Paint Charred Silicone Brass Chip	RTV, Tile (ORB TPS) Clay, Sand, Quartz (Landing Site) Metallics - BSM Residue (SRB)	Sand, Silicates (Landing Site) Foam (ORB) RTV (ORB TPS) Koropon, Kepton (ORB) Metallics - BSM Residue (SRB)	OMS Pod - PVC Laminate (ORB TPS 'Shirt')
30R	Metallics - BSM Residue (SRB) RTV, Tile (ORB TPS) Insulation Glass (ORB TPS) Clay, Salt (Landing Site) Paint	Metallics - BSM Residue (SRB) RTV, Tile (ORB TPS) Gap Filler (ORB TPS) Clay, Feldspar (Landing Site)	Metallics - BSM Residue (SRB) RTV, Tile (ORB TPS) Gap Filler (ORB TPS) Clay, Feldspar (Landing Site)		Upper Tile - Tile, Gap Filler (ORB TPS)

FIGURE 21. Orbiter Post Landing Microchemical Sample Results

STS	Sample Location				Other
	Windows	Wing RCC	Lower Tile Surface	Umbilical	
29R	RTV, Tile (ORB TPS) Metallics - BSM Residue (SRB) Ablator, Hypalon Paint (SRB)		Tile (ORB TPS) Insulation Glass (ORB TPS) Paint Muscovite - Metallics (Landing Site)	Tile (ORB TPS) Umbilical Foam (ORB) Paint Ablator, Hypalon Paint (SRB) Metallics - BSM Residue (SRB)	Upper Tile - Tile (ORB TPS)
27R	RTV, Tile (ORB TPS)	Hypalon Paint (SRB)	RTV, Tile (ORB TPS) Ablator, Hypalon Paint (SRB)		OMS Pod - Iron Fiber - PDL Foam, FRL Paint (ET) - Ablator, Hypalon Paint (SRB)
28R			RTV, Tile (ORB TPS) Paint Rust		

Sample locations vary per mission and not all locations are sampled for every mission.

() - identifies the most probable source for the material.

Metallics - includes mostly Aluminum and Carbon Steel alloys

FIGURE 21. Orbiter Post Landing Microchemical Sample Results

10.0 POST LAUNCH ANOMALIES

Based on the debris inspections and film/video review, ten Post Launch Anomalies, but no IFA candidates, were observed on the STS-55 mission.

10.1 LAUNCH PAD/SHUTTLE LANDING FACILITY

1. A dark, slender debris object fell from the LO2 TSM door area after the T-0 umbilical carrier plate had been retracted. The object fell aft without contacting flight hardware (E-17, frame 4255; E-20, frame 4805).
2. A 3" x 0.5" GSE shim fell from the LH2 T-0 umbilical carrier plate shortly after T-0 (E-18, frame 4206).

10.2 EXTERNAL TANK

1. Six divots, 6-8 inches in diameter, were present in the LH2 tank-to-intertank flange closeout: 4 in the -Y+Z quadrant and 2 in the -Y-Z quadrant. One 8-inch divot occurred in the inter-tank acreage between the left bipod ramp closeout and the -Y thrust panel (-Y+Z quadrant). At least 15-20 small "popcorn" type divots were visible on intertank stringer heads in an area just forward of the bipods. Two of those divots, measuring 6 inches in length, occurred just forward of the left bipod spindle area.
2. The right bipod jack pad closeout appeared to be missing and green primer was exposed.
3. Three 6-inch divots were present in the LH2 tank acreage: one aft of the RH bipod ramp and two in the -Y+Z quadrant near the LH2 tank-to-intertank flange closeout.

10.3 SOLID ROCKET BOOSTERS

1. The RH frustum was missing no TPS, but had 32 MSA-2 debonds over fasteners. The LH frustum had a total of 21 MSA-2 debonds over fasteners. A 1-inch diameter piece of MSA-2 was missing from an area between the 275 and 318 ring frames near the -Z axis.
2. Five areas of MSA-2, the largest of which measured 3" x 2.5", were missing from the LH aft skirt acreage TPS. Two other 3 inch diameter areas of MSA-2 were debonded.

3. A piece of the HDP #4 EPON shim may have been detached prior to splashdown. Part of the HDP #3 inboard sidewall EPON shim material was missing prior to water impact and may have been the two pieces observed in the film review falling from the aft skirt foot/holddown post area.

4. An NSI detonator was wedged between the HDP #4 DCS plunger and the stud hole wall. The HDP #5 DCS plunger was obstructed by frangible nut halves.

10.4 ORBITER

1. The RH ET/ORB attach point (EO-3) hole-plugger had not seated fully and was obstructed by a frangible nut half. Two ordnance fragments (P/N SKD26100-099-409 and NBS-RE1-8) were found on the runway below the LO2 ET/ORB umbilical after the ET doors were opened.

Appendix A. JSC Photographic Analysis Summary



ENGINEERING AND SCIENCE PROGRAM
2400 NASA Road 1, P. O. Box 58561, Houston, Texas 77258-8561

(713) 333-5411

June 11, 1993

Greg Katnik
MC/TV-MSD-22
OSB Room 5203R
KSC, Florida 32899

Dear Greg,

The following Summary of Significant Events report is from the Johnson Space Center NSTS Photographic and Television Analysis Project, STS-55 Final Report, and was completed June 11, 1993. Publication numbers are LESC-30782 and JSC-25994-55. The actual document can be obtained through the LESC library/333-6594 or Christine Dailey /483-5336 of the NSTS Photographic and Television Analysis Project.

Christine Dailey 6/11/93
Christine Dailey, Project Specialist
Photo/TV Analysis Project

2.0 Summary of Significant Events

2.1 Debris

2.1.1 Debris near the Time of SSME Ignition

2.1.1.1 LH2 and LO2 Umbilical Disconnect Debris

(Cameras E-5, E-6, E-16, E-17, E-18, E-19, E-25, E-26, E-31, E-34, E-40, E-52, E-76, E-77, E-79, OTV-009, OTV-054 and OTV-063)

Normal ice debris was noted falling from the LH2 and LO2 ET/Orbiter umbilical disconnect areas as well as from the LH2 and LO2 T-0 TSM umbilical areas at Space Shuttle Main Engine (SSME) ignition through liftoff. None of the debris was observed to strike the vehicle. No follow-up action has been requested.

2.1.1.2 Rectangular Shaped Debris *(Camera E-18)*

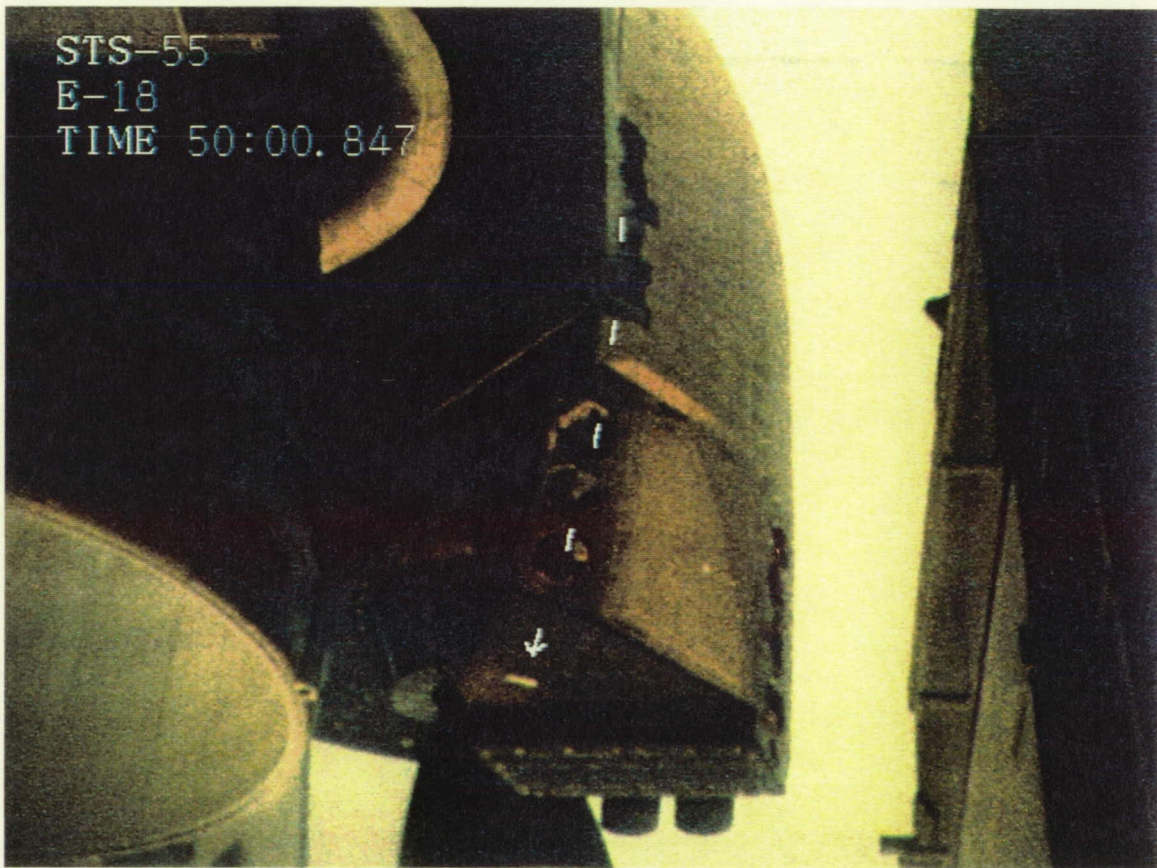

Figure 2.1.1.2

Rectangular Shaped Debris From LH2 T-0 TSM Umbilical Area

A small, thin, rectangular shaped piece of debris, dark on one side and light on the other, fell from the LH2 T-0 TSM umbilical area after umbilical disconnect. In addition, two small rectangular shaped pieces of debris, dark on one side and light on the other, were first seen at the left inboard elevon lower surface and fell aft through the field of view. The origin of these three pieces could not be determined from the films.

2.0 Summary of Significant Events

2.1.2 Debris near the Time of SRB Ignition

2.1.2.1 SRB Flame Duct Debris (Task #7) *(Cameras E-4, E-14, E-30, E-57)*

At least two separate fast moving pieces of SRB flame duct debris were noted coming from the LSRB at liftoff. On Camera E-30, debris was seen to come from the LSRB flame duct beginning at 14:50:01.92 UTC. It had a 2D velocity of 70 ft/sec and a size of approximately 4.4 inches. The debris seen on camera E-14 was first detected at 14:50:00.307 UTC and had a 2D velocity of approximately 69 ft/second and a size of approximately 1.3 inches across.

The debris seen on E-57 was first noted just to the west of the RSRB at approximately 14:50:02 UTC and may have originated from the LSRB flame duct. The debris appeared to travel approximately 40 feet above base of the MLP and had a maximum 2D velocity of approximately 125 ft/sec. The debris seen on E-4 was first seen at approximately 14:50:02 UTC and appeared to originate from the LSRB flame duct. It had a 2D velocity of approximately 136 ft/sec.

Although it can not be confirmed, it appears, based on the times and velocities, that the debris seen on cameras E-4 and E-57 may have been the same object. The debris seen on camera E-30 was seen at the same time as the debris seen in cameras E-4 and E-57 but the velocity was much less and thus may not have been the same piece of debris. The debris seen on camera E-14 was probably a separate object since it was too small to be the object seen on E-30 and too slow to be the object seen on E-4 and E-57. For more details on this analysis see Appendix D, Task #7.

2.1.3 Debris after Liftoff

2.1.3.1 RCS Paper and Baggie Material Debris *(Cameras E-52, E-57, E-63, E-65, E-76, E-77, E213, E-222, E-223)*

Multiple pieces of debris were seen falling aft of the Shuttle Launch Vehicle (SLV) at liftoff and throughout ascent on the launch tracking views. Most of the debris sightings were probably reaction control system (RCS) paper or ice/baggie material from the ET/Orbiter umbilicals. Two pieces of light colored debris (possibly ice) fell from the ET LO2 feed line upper bellows at liftoff. None of the debris was observed to strike the vehicle. No follow-up action has been requested.

2.1.3.2 Debris Reported by Crew (Task #10)

Shortly after launch, the crew was asked to give a report of the debris they noted. Commander Steve Nagel reported that there were a few smudges on the windows but that they appeared normal. He also reported that after ET separation, a great deal of venting was noted on the left side of the Orbiter. He said the venting appeared as a water dumplet with a shower of very small particles. Pilot Tom Henricks reported that most of the debris noted was near the left side of the Orbiter. A transcript of their conversation is in Appendix D, Task #10.

2.0 Summary of Significant Events

2.2 MLP Events

2.2.1 Orange Vapor (Possibly Free Burning Hydrogen) (Cameras E-1, E-3, E-5, E-17, E-18, E-19, E-20, E-30, E-36, E-52, E-63, E-76, E-77, OTV-063)

An orange vapor, possibly free burning hydrogen, was noted beneath the SSMEs and drifted under the body flap prior to SSME ignition. This phenomenon has been noted on many previous missions.

2.2.2 Discoloration in SSME Plume After SSME Ignition (Cameras E-2, E-3, E-15, E-16, E-20, E-63 and OTV-151)

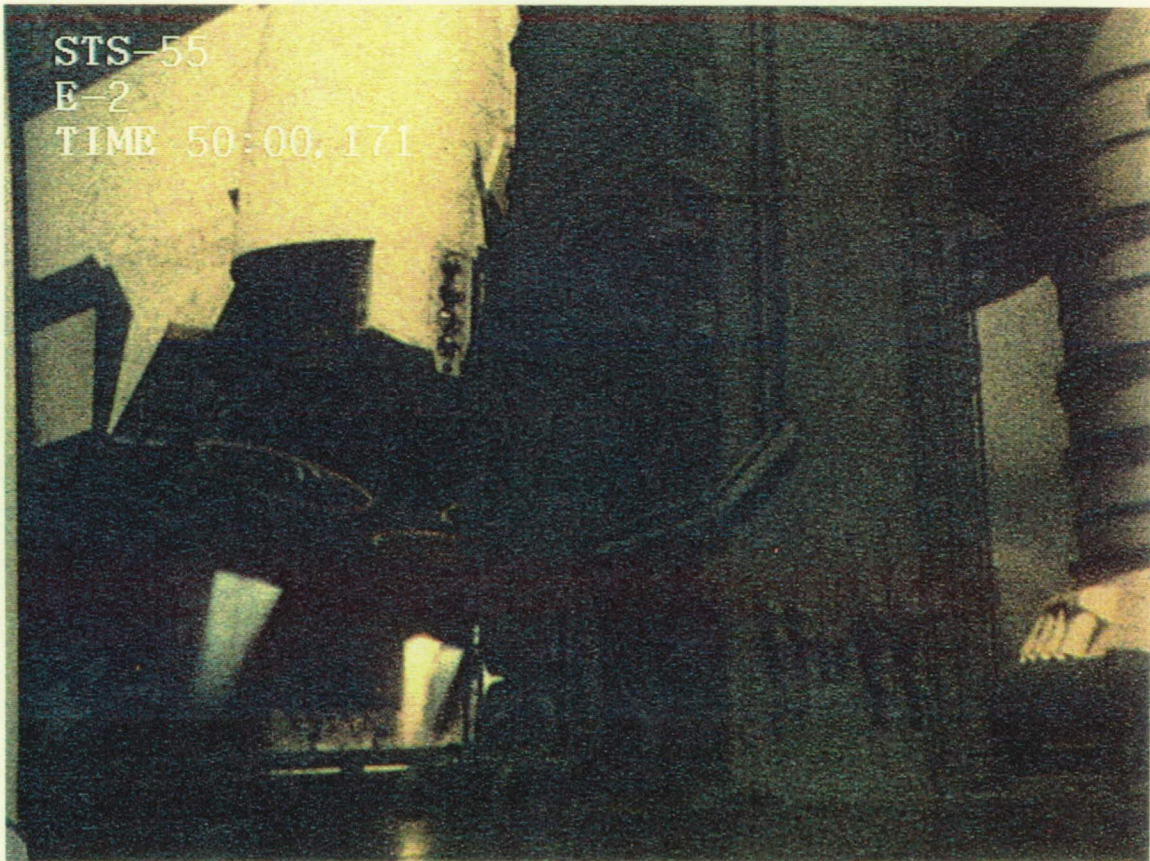

Figure 2.2.2 SSME #2 Plume Discoloration

A white discoloration was noted in the SSME #2 mach diamond at 0.144 seconds MET. This type of phenomenon has been seen on several previous missions.

2.0 Summary of Significant Events

2.3 Ascent Events

2.3.1 Electro-Magnetic Disturbance (*Task # 13*)

The MER reported that at 47 to 50 seconds MET, the Lightning Detector and Ranging System (LDAR) and the UHF Receiver #4 simultaneously registered an electromagnetic disturbance. The preliminary conclusion by the JSC Tracking and Communications Division is that there was a dielectric breakdown between the Shuttle and the surrounding atmosphere. This atmospheric breakdown precipitated an electrostatic discharge due to prior P-static charge buildup, a low amplitude lightning strike, or a combination of the two.

Visual Analysis:

The following STS-55 launch videos and films were re-screened to see if there was any visual manifestation of an electromagnetic disturbance between 47.98 to 50.29 seconds MET: KTV-13, KTV-21A, ET-204, ET-207, ET-208, ET-212, ET-213, KTV-4A, E-52, E-54, E-204, E-205, E-208, E-213, E-222. No visual indication of a possible electromagnetic disturbance was found. On cameras E-54, E-213, and E-222, the vehicle is visible continuously from liftoff through 54 seconds MET and beyond. These views indicate that the vehicle was not in visible moisture during the 47 to 50 second time period.

On KTV-4A, a condensation "collar" formed around the forward portion of the SLV after the roll maneuver. The condensation collar is no longer visible after 44 seconds MET. The condensation starts to reappear at 50 seconds MET, again at 51 seconds MET and finally is distinctly visible at 54 seconds MET. There is no visible indication of condensation around the SLV on any of the tracking video and film camera views during the 47 to 50 second time period when the electromagnetic disturbance was registered on the LDAR and the UHF receiver.

Pre-Launch STS-55 Trajectory Data:

An examination of the STS-55 pre-launch trajectory data shows that at 47.04 seconds MET the vehicle was at an altitude of 21,792 feet and a velocity of mach 0.98. At 48 seconds MET the vehicle was at 22,649 feet and a velocity of mach 1.00. At 50.88 seconds MET the vehicle was at 25,295 feet and a velocity of mach 1.07.

Environmental Analysis:

Rawinsonde Data: Vertical moisture profile indicated moisture layers at 17,856 ft (68%) and 29,836 ft (44%). These layers by themselves do not conclusively prove that clouds existed at launch but the relative humidities do not rule out clouds either. It should also be noted that this data was gathered 30 minutes before launch and may not reflect conditions at launch. A table containing the Cape Canaveral Air Force Station Rawinsonde Data for April 26, 1992 at 14:20:00 GMT is located in Appendix E.

GOES7 Satellite Imagery: Broad-scale satellite imagery taken at 15:01:00 GMT indicates thin cirrus clouds existed over the launch corridor during ascent. Cirrus clouds are very difficult to detect in the visible spectrum (nearly optically transparent) which may explain why the visual analysis was inconclusive. GOES7 thermal imagery (11.5 microns) is better suited to detect thin cirrus and, in fact, did detect these clouds in the launch corridor.

2.0 Summary of Significant Events

Origin of Cirrus Clouds Observed at Launch:

Examining a single pair of GOES visible and infrared data cannot provide conclusive evidence of the origin of the cirrus clouds observed at launch. Rawinsonde data does aid the estimated trajectory of these clouds. The winds carrying the clouds were from about 290 degrees (west-north-west). Moving up-stream in this direction on the GOES7 satellite image, an area of thunderstorms and thunderstorm anvils or debris is found along an axis from offshore Apalachicola, Florida through Charleston, South Carolina. The proximity of these active thunderstorms along with the general flow pattern suggests the possibility that the cirrus clouds over the launch corridor were of a thunderstorm debris nature. If this is the case, it is also possible that these same clouds may have carried a residual charge (positive) that could have been dissipated onto the Orbiter and its associated contrail as the Orbiter passed through the (potentially) charged cirrus debris layer.

2.3.2 Body Flap Motion (Task #4) (Cameras E-18 and E-212)

The amount of body flap motion seen at SSME ignition did not warrant further analysis. At present, there is an ongoing study of this type of motion on OV-103 missions.

There was also slight body flap motion visible during ascent as the vehicle passed through Max-Q (the region of maximum dynamic pressure). Once again, the amount of motion seen on this mission did not require further analysis. However, a table listing those missions where numerical analysis has been performed in the past is listed in Appendix D, Task #4 - Body Flap Motion.

2.3.3 Recirculation (Task #1) (Cameras E-204, E-208, E-218, ET-208, KTV-13)

The recirculation or expansion of burning gases at the aft end of the SLV prior to SRB separation has been seen on nearly all previous missions. For STS-55 the start of recirculation was observed at about 94 seconds MET on E-204 and the end was noted at approximately 110 seconds MET on Camera KTV-13. See Appendix D, Task #1 for a summary of recirculation start and stop times for all missions since reflight.

Cameras on which recirculation was observed for STS-55

CAMERA	START (seconds MET)	STOP (seconds MET)
KTV-13	95	111
ET-208	-	-
E-204	102	112
*E-208	94	110
E-218	-	-

* BEST VIEW OF RECIRCULATION

NOTE: Intermittent LOV of the vehicle due to clouds prevented acquisition of specific start and stop times for recirculation on cameras ET-208 and E-218.

2.0 Summary of Significant Events

2.4 DTO-312

2.4.1 Analysis of Onboard Photography of the ET (Task #6) (STS-55-71-001 through -034)



Figure 2.4.1 Divots on the External Tank

Thirty-four photographs of the ET after separation were taken by the crew between 15:03:39 UTC and 15:22:49 UTC with a Hasselblad 70 mm format camera configured with a 250 mm lens. Five divots were seen on the +Y+Z area near the LH2 intertank close-out. Divot 1 (see Figure 2.4.1) is on the close-out area and divots 2 through 5 are below it. A sixth divot, not shown in the figure above, was noted on the +Y-Z area on the LH2 intertank close-out. Based on scaling the divots by the diameter of the ET, the divots ranged in size from 4.7 inches (divot 4) to 19.9 inches (divot 6). At the time of the first photograph, the ET was 1130 meters from the orbiter. At the time the last photograph, the ET was 8677 meters away from the orbiter. Further details are given in Appendix D, Task #6.

2.0 Summary of Significant Events

2.4.2 Umbilical Well Camera Analysis (*Task #5*)

2.4.2.1 16 mm Views of SRB and ET Separation

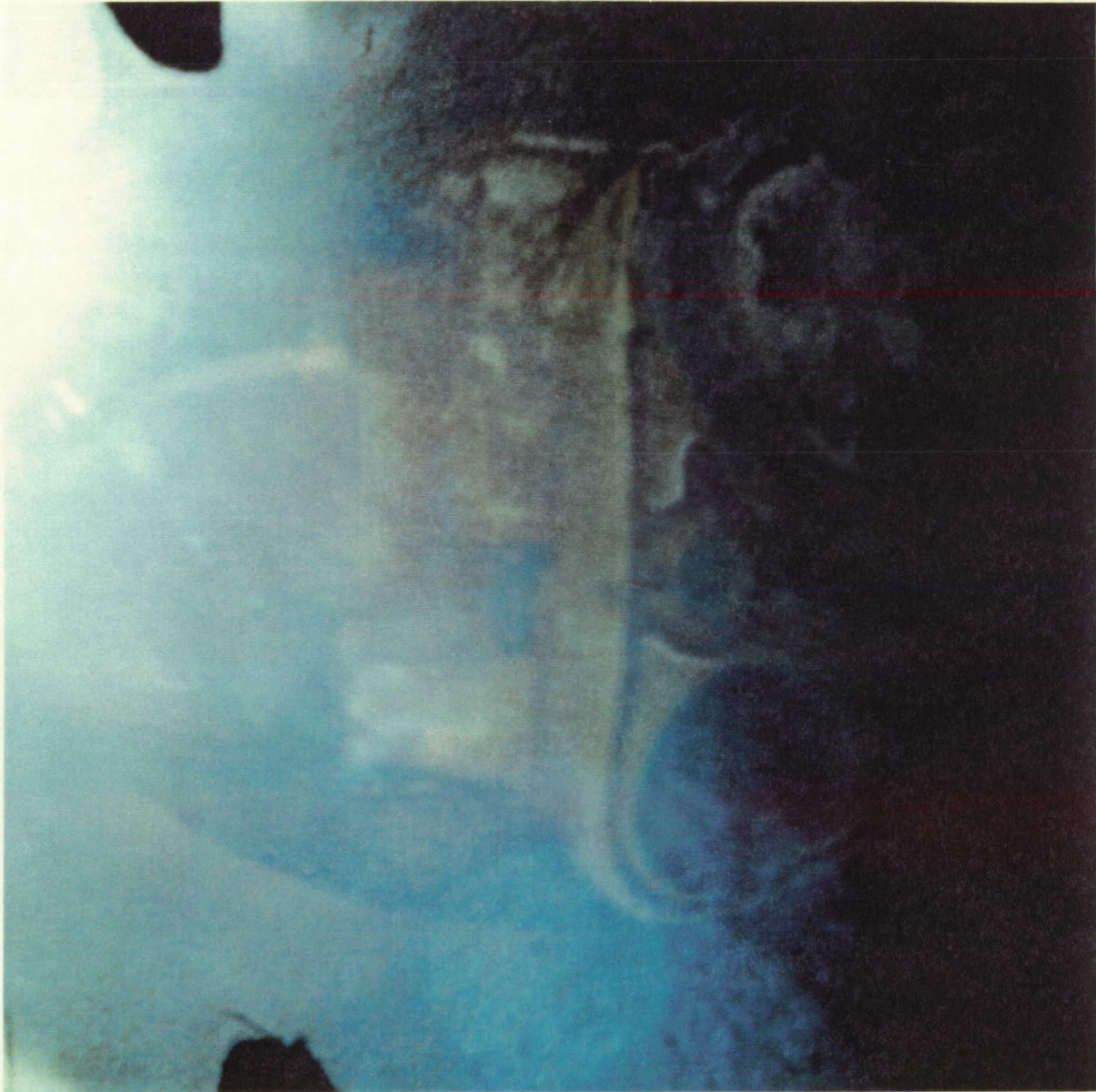

Figure 2.4.2.1 16 mm Camera View of the LH2 Umbilical

A 16 mm motion picture film was taken from the Orbiter umbilicals and reviewed. This motion picture film showed LSRB and ET separation along with the normal venting and debris associated with these events. Due to the large amount of debris seen by the crew after ET separation, it was thought that perhaps the LH2 4" purge valve may not have closed properly. The 4" purge line appeared normal and no venting was noted from the ET. Poor imagery due to sun glint significantly hindered analysis. Normal TPS erosion was noted. No anomalies were detected.

2.0 Summary of Significant Events

2.4.2.2 35 mm Umbilical Well Camera Views of the ET Separation

Fifty-nine well focused 35 mm frames were obtained of the external tank separation. These frames showed multiple small white areas (probably TPS erosion) near the aft dome and LO2 feed line. A bright glare hampered analysis on the nineteenth frame. The photography also showed two of the five divots near the LH2 intertank close-out area which were also seen on the 70 mm Hasselblad magazine (See Section 2.4.1). The screening sheets are located in Appendix D, Task #5.

2.5 Landing Events

2.5.1 Landing Sink Rate Analysis Using Film (*Task #3*) (*Camera E-1034R*)

Camera E-1034R was used to determine the left main gear sink rate. Data was gathered for 25 frames prior to and throughout landing, approximately 1 second. This film did not contain timing. However, left main gear touchdown occurred at frame 404 which was timed to be 126:14:29:58.982 UTC as seen on DTV 1. Drag chute initiation occurred at frame 811 and 126:14:30:14.973 UTC as seen on DTV 4. The 407 frames took 15.991 seconds or 25.45 frames per second. Scale was determined using the photographic distance of the diameter of the inside left main gear tire. To find the height of the main gear above the runway was determined by multiplying the image distance by the scale. These heights were plotted with respect to time to find the actual main gear sink rate. The analysis showed that the main gear sink rate was 3.46 feet per second. A graph depicting the above data can be seen in Appendix D, Task #3. No nose gear sink rate information was collected from film due to lack of timing information.

2.5.2 Landing Sink Rate Analysis Using Video (*Task #3*) (*Camera DTV-1*)

Camera DTV-1 was used to determine the sink rate of the main gear. Data was gathered approximately 1 second prior to landing through touchdown at a rate of 30 frames per second. Scalar information was determined by a system of equations which took into account the orientation of the orbiter relative to the camera. The equations were solved for each observation which took into account the change in perspective as well as increase in size. The vertical distance between the average position of the main gear and the runway was then multiplied by the scale to find the height of the main gear above the runway. These heights were then regressed with respect to time to find the actual main gear sink rate. The analysis showed that the main gear sink rate was 3.55 feet per second.

Nose gear touchdown occurred approximately 18 seconds after main gear touchdown. Camera DTV-1 was used to determine the sink rate of the nose gear. Data was gathered approximately 1 second prior to landing through touchdown at a rate of 30 frames per second. Scalar information was found for nose gear sink rate in the same manner in which it was found for main gear sink rate. The vertical distance between the nose gear position and the average position of the main gear was then multiplied by the scale to find the vertical distance between the nose gear and the main gear. The difference between the radius of the main gear and nose gear tires was then added to this distance to find the height of the nose gear above the runway. These heights were then regressed with respect to time to find the actual nose gear sink rate. This rate was determined to be 3.18 feet per second. Graphs depicting the above data can be seen in Appendix D, Task #3.

2.0 Summary of Significant Events

2.5.3 Drag Chute Performance (Task #9) (Cameras DTV-1, DTV-4)

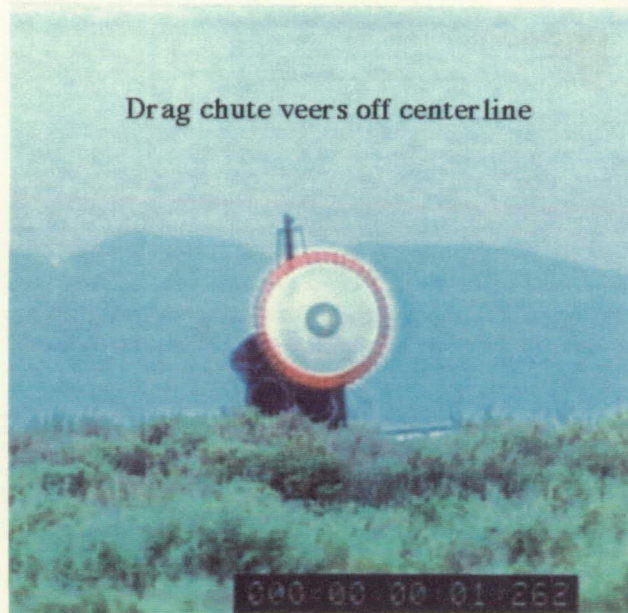

Figure 2.5.3 Drag Chute Veers From Center Line of the Orbiter

Video coverage of the drag chute deployment was obtained. The deployment of the drag chute appeared as expected. The drag chute was seen to veer to the right after deployment (See Figure 2.5.3). Analysis of the drag chute performance was not done this mission due to limited film coverage, the lack of timing, and the fact that the drag chute has been modified since STS-55 and this configuration will no longer be used.

All drag chute times were obtained from camera DTV-1 except for initiation which was obtained from camera DTV-4.

14:30:14.973 UTC Drag chute initiation
14:30:15.965 UTC Pilot chute inflation
14:30:17.600 UTC Drag chute inflation in reefed configuration
14:30:21.037 UTC Drag chute inflation in disreefed configuration
14:30:40.690 UTC Drag chute release

2.0 Summary of Significant Events

2.5.4 Post Landing Orbiter Inspection

Bolt protrudes from LH2 umbilical 4" line attach



(A)

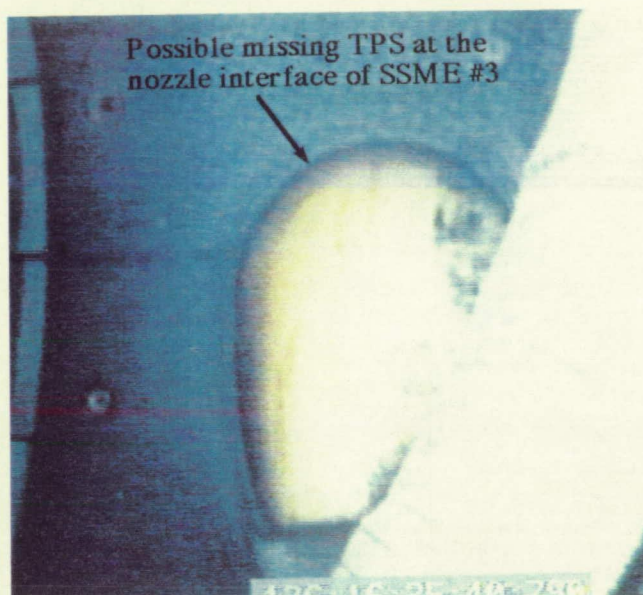

(B)

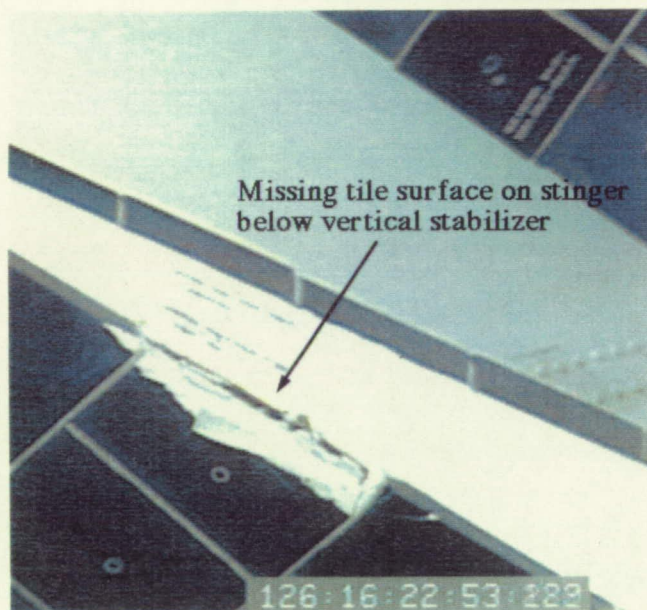

(C)

Figures 2.5.4 A, B, and C

(A) Bolt With Hexagonal Nut, (B) Possible Missing TPS at Base of SSME #3 (C) Missing Tile Surface on Stinger

The following items were noted during the post-landing inspection of the Orbiter:
A bolt with a hexagonal nut was seen protruding approximately 5/16" from the LH2 umbilical in the attach associated with the 4" recirculation line (See Figure 2.5.4 A).

2.0 Summary of Significant Events

Missing tile surface material was noted on the stinger below the vertical stabilizer (See Figure 2.5.3 B). Possible missing TPS was noted in the SSME #3 nozzle interface area just inside the dome mounted heat shield at the three o'clock position (See Figure 2.5.3 C).

2.6 Other Normal Events

Other normal events observed include: frost buildup on SSME purge vent nozzles, ice/frost debris and vapor from the LH2 and LO2 ET/Orbiter umbilical areas at SSME start up through liftoff, frost on ET GOX vent louvers, ice/frost debris and vapor from the GUCP at disconnect, ice/frost debris and vapor from the LO2 T-0 TSM and the LH2 T-0 TSM disconnects at liftoff, ET twang, motion of the elevons and body flap at SSME startup and liftoff, vapor from the rudder speed brake drain port, ET aft dome outgassing, vapor from the SRB stiffener rings, minor pad debris in SLV exhaust plume, expansion waves, flares in the SSME plumes, white puffs in the SSME exhaust plume after the roll maneuver, body flap motion during ascent, charring of the ET aft dome, linear optical distortions, recirculation, plume brightening, and debris in SRB plume after SRB separation.

2.7 STS-55 Abort Analysis (Task #11)

2.7.1 Screening Activities

On Monday, March 31, 1993, the liftoff of Columbia was aborted after the SSMEs were shutdown at startup. Eight videos and twenty-one films were screened. An events timeline was created and can be found along with the screening information in Appendix D, Task #11. Other significant events that were not considered anomalies were noted during screening and are explained in Section 2.7.

2.7.1.1 Pre-Launch ET Tanking Screening (Cameras OTV-009, OTV-040, OTV-054, OTV-063, OTV-064)

Mission Evaluation Room (MER) engineering views were screened real-time during the tanking of the external tank which began approximately 8 hours prior to launch. The usual vapors and water drops were noted during tanking. White debris (probably frost) was noted to form on the ET/Orbiter umbilical baggie material at the liquid hydrogen (LH2) disconnect. No anomalies were detected. See Appendix D, Task #11 for the tanking timeline.

2.0 Summary of Significant Events

2.7.1.2 Significant Events

2.7.1.2.1 Shutdown of SSME #3 (Cameras E-3, E-5, E-15, E-17, E-19, E-20, E-62, E-77, OTV-051S, OTV-070S, OTV-071S)

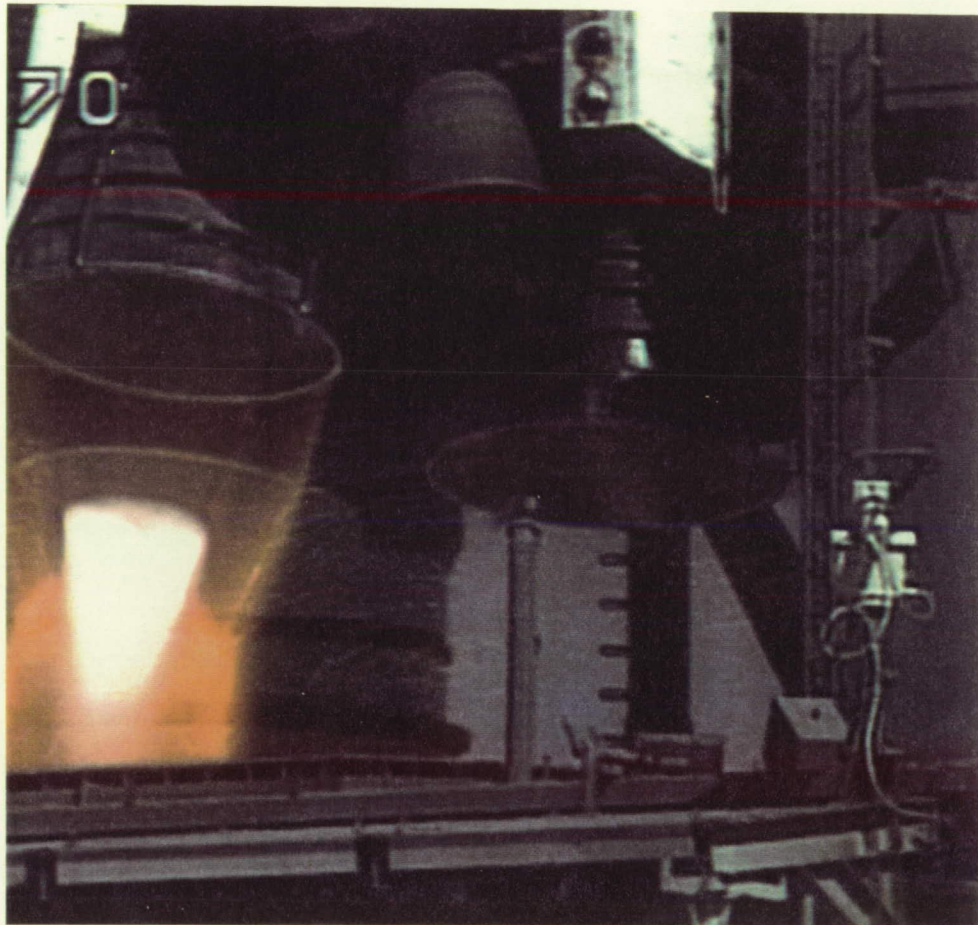

Figure 2.7.1.2.1 Shut Down of SSME #3

During the launch attempt of STS-55, SSME #3 was shut down by its main engine controller when a higher than allowable pressure reading showed up in a purge line (See Figure 2.7.1.2.1). The general purpose computers, responding to SSME #3 controller's report of a shutdown, began shutting down SSME #2 and then SSME #1. After all three engines were shut down, safing procedures that include a series of valve closures, leak checks and fire detection checks began. Thousands of gallons of water were then sprayed on the engines to extinguish any fires that may have been present.

2.0 Summary of Significant Events

2.7.1.2.2 Rectangular Shaped Debris (Camera E-18)



Figure 2.7.1.2.2 Rectangular Shaped Debris

A yellow, flexible, rectangular appearing piece of debris moved from left to right across the field of view. The origin was possibly the LH2 TSM T-0 umbilical area.

2.7.1.2.3 Orange Vapor at SSME Ignition (Cameras E-2, E-3, E-5, E-15, E-16, E-17, E-18, E-19, E-20, E-36, E-52, E-61, E-62, E-77, KTV-4AS, OTV-070S, OTV-071S)

Orange vapor, possibly free burning hydrogen, was noted below the SSMEs and above the rims of the SSMEs. It was also noted to travel beneath the body flap at SSME ignition.

2.0 Summary of Significant Events

2.7.1.2.4 Orange Vapor/Flames and Burning Debris Near LH2 TSM Umbilical (Cameras E-2, E-18, E-30)

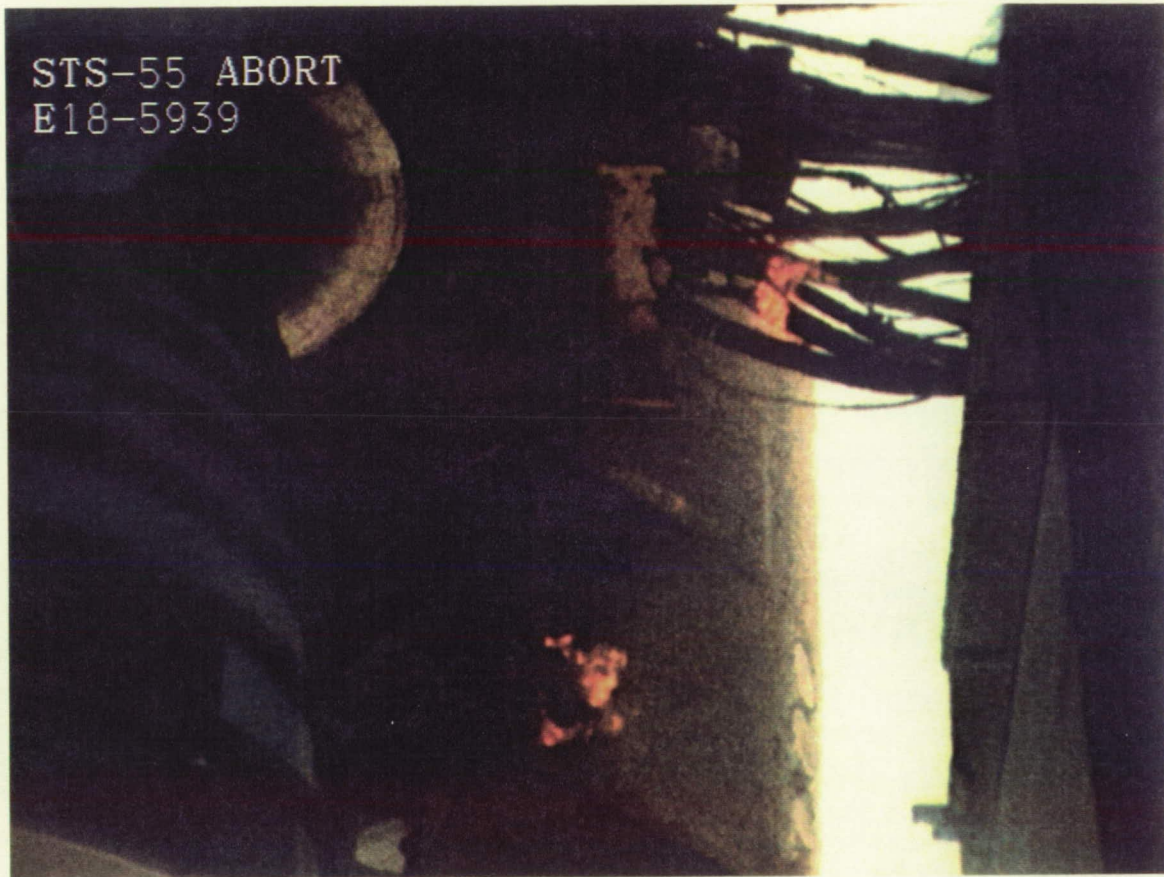

Figure 2.7.1.2.4 (A) Orange Vapor/Flames Near LH2 T-0 TSM Umbilical

Orange vapor or flames were noted at the lower lines of the LH2 T-0 umbilical area.

2.0 Summary of Significant Events

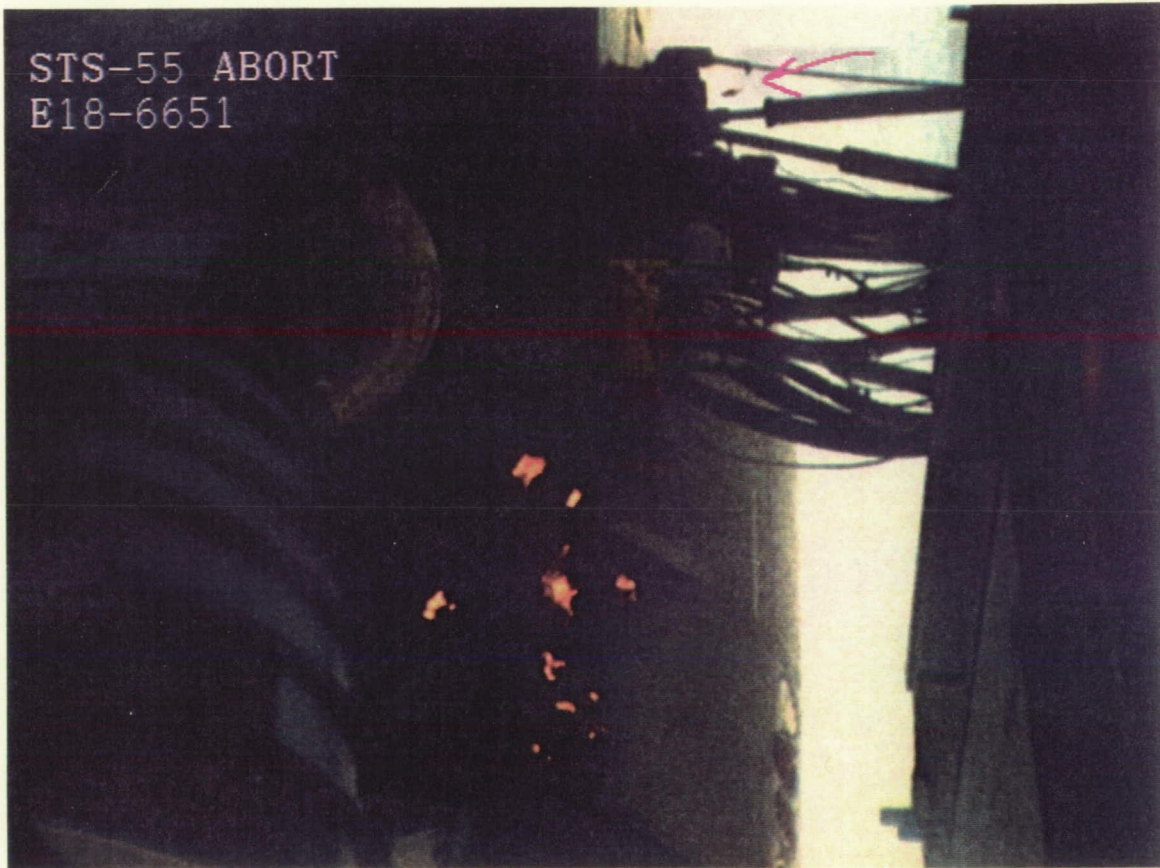

Figure 2.7.1.2.4 (B)

Burning RCS Paper

RCS paper from the left RCS stinger ignited and burned after engine shutdown. Pieces of the burning RCS paper were noted to drift across the field of view throughout the sequence.

2.7.2

Other Normal Events

FSS deluge water, body flap motion at SSME ignition, frost build up on SSME purge vent nozzles, APU venting on the RSRB, engine purge deluge water, and aft fuselage deluge water.

Appendix B. MSFC Photographic Analysis Summary



National Aeronautics and
Space Administration

George C. Marshall Space Flight Center
Marshall Space Flight Center, Alabama 35812

SPACE SHUTTLE
ENGINEERING PHOTOGRAPHIC ANALYSIS REPORT
STS-55

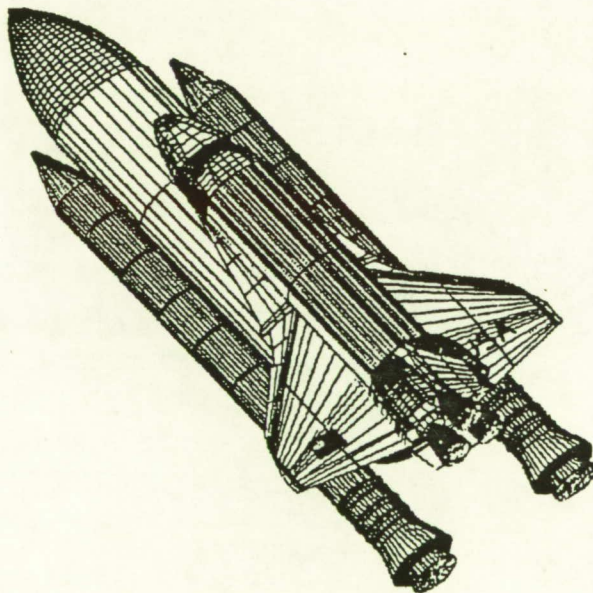

ENGINEERING PHOTOGRAPHIC ANALYSIS REPORT

STS-55

FINAL

PREPARED BY:

B. EPPS, J. HIXSON, B. VIGER
PHOTOGRAPHIC ANALYSIS/ROCKWELL/HSV

SUBMITTED BY:

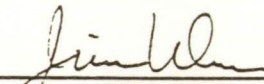

JIM ULM

SUPERVISOR, LAUNCH OPERATIONS/ROCKWELL/HSV

APPROVED BY:



T. RIECKHOFF, MSFC/EP24

B. LINDLEY-ANDERSON, MSFC/EP24

STS-55 ENGINEERING PHOTOGRAPHIC ANALYSIS REPORT

TABLE OF CONTENTS

- I. INTRODUCTION
 - II. ENGINEERING ANALYSIS OBJECTIVES
 - III. CAMERA COVERAGE ASSESSMENT
 - A. GROUND CAMERA COVERAGE
 - B. ONBOARD CAMERA COVERAGE
 - IV. ANOMALIES/OBSERVATIONS
 - A. GENERAL OBSERVATIONS
 - B. SRB MAIN PARACHUTE RIP
 - C. ET TPS DIVOTS
 - V. ENGINEERING DATA RESULTS
 - A. T-0 TIMES
 - B. ET TIP DEFLECTION
 - C. SRB SEPARATION TIME
- APPENDIX A - FIGURES
- APPENDIX B - INDIVIDUAL FILM CAMERA ASSESSMENT *
- APPENDIX C - INDIVIDUAL VIDEO CAMERA ASSESSMENT *

* Photographs in the individual camera assessments are representative photographs and are not necessarily photographs taken from this particular launch.

May 17, 1993

I. INTRODUCTION

Space Shuttle Mission STS-55, the fourteenth flight of the Orbiter Columbia was conducted April 26, 1993 at approximately 9:50 A.M. Central Daylight Time from Launch Complex 39A (LC-39A), Kennedy Space Center (KSC), Florida. Extensive photographic and video coverage was provided and has been evaluated to determine proper operation of the ground and flight hardware. Cameras (video and cine) providing this coverage are located on the fixed service structure (FSS), mobile launch platform (MLP), LC-39B perimeter sites, onboard, and uprange and downrange tracking sites.

II. ENGINEERING ANALYSIS OBJECTIVES:

The planned engineering photographic and video analysis objectives for STS-55 included, but were not limited to the following:

- a. Overall facility and Shuttle vehicle coverage for anomaly detection
- b. Verification of cameras, lighting and timing systems
- c. Determination of SRB PIC firing time and SRB separation time
- d. Verification of Thermal Protection System (TPS) integrity
- e. Correct operation of the following:
 1. Holddown post blast covers
 2. SSME ignition
 3. LH2 and LO2 17" disconnects
 4. GH2 umbilical
 5. TSM carrier plate umbilicals
 6. Free hydrogen ignitors
 7. Vehicle clearances
 8. GH2 vent line retraction and latch back
 9. Vehicle motion

There was one special test objective for this mission:

- a. DTO-0312, ET photography after separation

III. CAMERA COVERAGE ASSESSMENT:

Film was received from fifty-five of fifty-six requested cameras as well as video from all twenty-four requested cameras. The following table illustrates the camera data received at MSFC for STS-55.

CAMERA DATA RECEIVED FOR STS-55

	<u>16mm</u>	<u>35mm</u>	<u>70mm</u>	<u>Video</u>
MLP	22	0	0	4
FSS	7	0	0	3
Perimeter	3	3	0	6
Tracking	0	15	0	11
Onboard	3	1	1	0
Totals	35	19	1	24

A detailed individual motion picture camera assessment is provided as Appendix B. Appendix C contains detailed assessments of the video products received at MSFC.

a. Ground Camera Coverage:

Photographic coverage of STS-55 was considered good. Tracking camera coverage was degraded due to cloud cover and atmospheric conditions. Camera E-220 did not run due a mechanical failure.

b. Onboard Camera Assessment:

A camera was flown on each SRB forward skirt to record the main parachute deployment. Both cameras operated properly and recorded data through water impact. The astronauts carried a 70mm hand-held camera to record film for evaluating the ET TPS integrity after ET separation. Thirty-one frames of data were recorded. Also a 16 mm Arriflex camera was used to record data of the ET after separation. Two 16mm motion picture cameras and one 35mm still camera were flown on this mission in the orbiter's umbilical well to record the SRB and ET separation events. The 16mm camera with the 10mm lens did not run.

IV. ANOMALIES/OBSERVATIONS:

a. General Observations:

While viewing the film, several events were noted which occur on most missions. These included: pad debris rising and falling as the vehicle lifts off; debris induced streaks in the SSME plume; ice falling from the 17" disconnects and umbilicals; and debris particles falling aft of the vehicle during ascent,

which consist of RCS motor covers, hydrogen fire detectors and purge barrier material. Body flap and inboard right elevon motions were noted during ascent.

b. SRB Main Parachute Rip

At first disreef a large rip was observed in one of the parachutes on the right SRB. The rip is approximately 1/8 of the diameter of the parachute or approximately 30 feet. Figure 1 is a frame of film from camera E-301 showing the rip.

c. ET TPS Divots

Thirty-one frames of 70mm film of the ET after separation were received and reviewed. Four divots were noted on the LH2 tank to the left of the forward bipod and two divots noted at the LH2/intertank scarf joint. Figure 2 is a frame of film taken from the 70mm on board camera showing these divots.

V. ENGINEERING DATA RESULTS:

a. T-Zero Times:

T-Zero times are determined from cameras which view the SRB holddown posts numbers M-1, M-2, M-5 and M-6. These cameras record the explosive bolt combustion products.

POST	CAMERA POSITION	TIME (UTC)
M-1	E-9	116:14:50:00.024
M-2	E-8	116:14:50:00.025
M-5	E-12	116:14:50:00.025
M-6	E-13	116:14:50:00.024

b. ET Tip Deflection:

Maximum ET tip deflection for this mission was determined to be approximately 30.5 inches. Figure 3 is a data plot showing the measured motion of the ET tip in both the horizontal and vertical directions. These data were derived from camera E-79.

c. SRB Separation Time:

SRB separation time for STS-56 was determined to be 116:14:52:05.55 UTC as recorded by camera E-207.

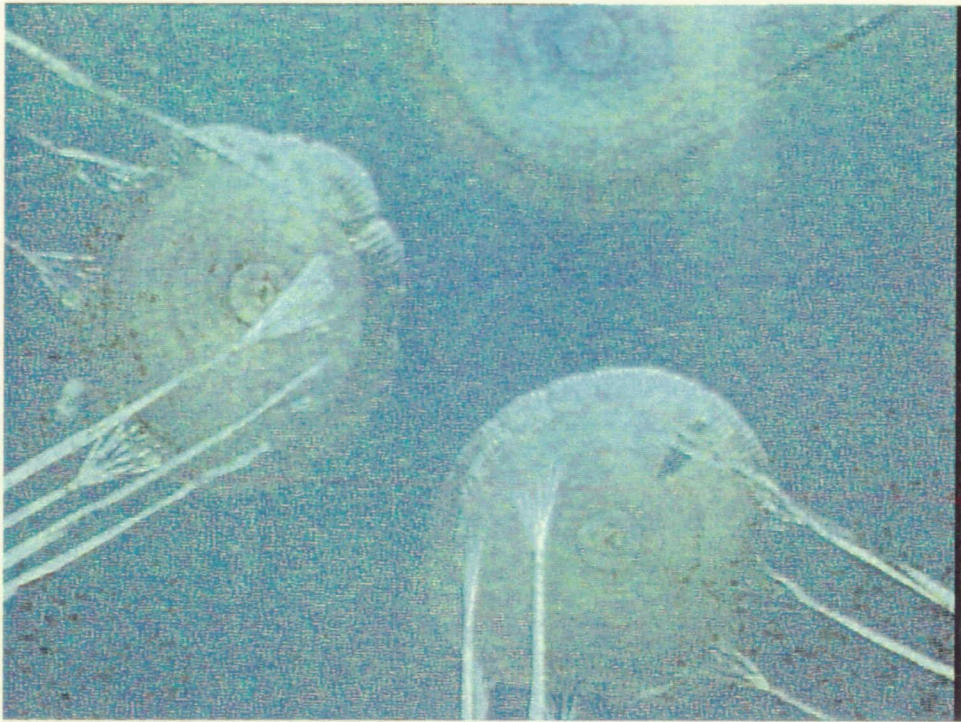

Figure 1.

Rip in Right SRB Main Parachute

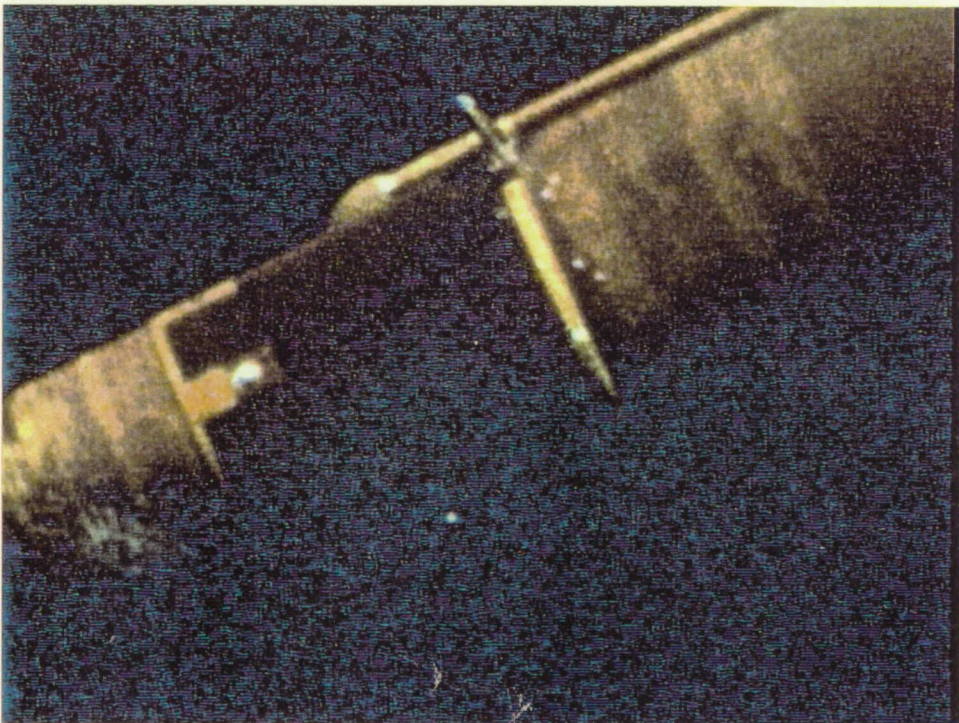
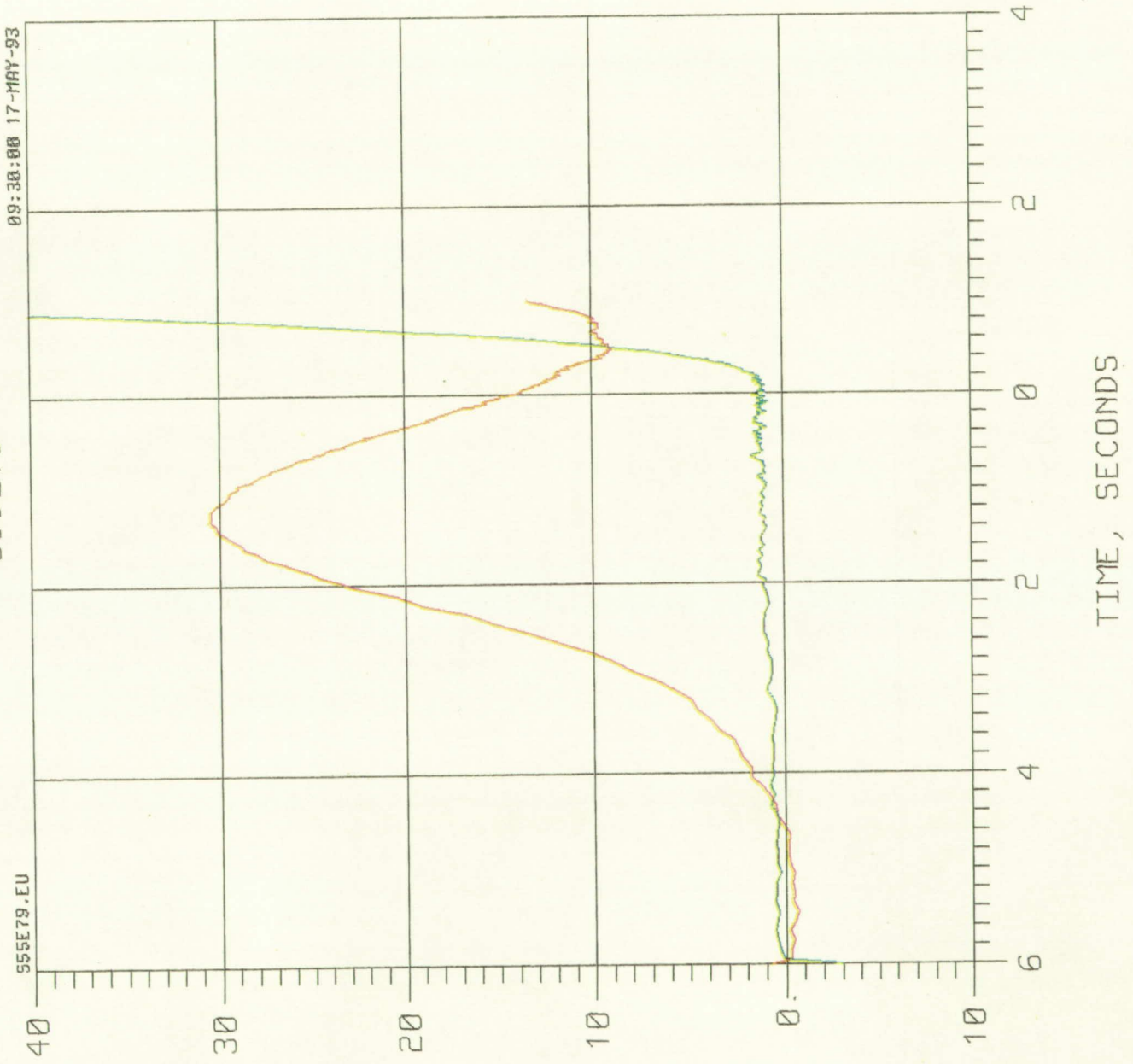

Figure 2.

ET TPS Divots

ET TIP DEFLECTION

S55E79



— HORIZ. DISPL.

— VERT. DISPL.

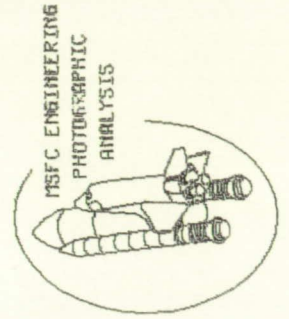

DEFLECTION, INCHES

TIME, SECONDS

Figure 3

Appendix C. Rockwell Photographic Analysis Summary

Space Transportation Systems Division
Rockwell International Corporation
12214 Lakewood Boulevard
Downey, California 90241



Rockwell
International

June 8, 1993

In Reply Refer to 93MA2124

National Aeronautics and Space Administration
Lyndon B. Johnson Space Center
Houston, Texas 77058

Attention: L. G. Williams (WA)

Contract NAS9-18500, System Integration, Transmittal of the Rockwell Engineering Photographic Analysis Report for the STS-55 (Launch Abort) and STS-55 Mission.

The System Integration Contractor hereby submits the Engineering Photographic Analysis Summary Report in accordance with the Space Shuttle Program Launch and Landing Photographic Engineering Evaluation Document (NSTS 08244).

The scheduled launch of STS-55 on March 22, 1993 was aborted at T-3 seconds (6:51 am PST/GMT 081:14:50:54.956) due to a problem with SSME#3.

As a result of the launch abort several films were selected by MSFC and JSC to provide possible data in the evaluation of the STS-55 launch abort.

Rockwell received 21 films for the photographic evaluation effort. One film, E-76 was not available due to camera malfunction.

Review of films E-19 and E-20 did not identify any visual anomalies or other off-nominal occurrences on the external surfaces of the three SSME's. Ignition of SSME's #3 and #2 appeared to stop during startup and no Mach diamond was formed. A Mach diamond was noted on SSME #1 which dissipated about half a second later. After the engine's shutdown, frost was noted forming on the nozzles.

After SSME shutdown, an orange vapor (possibly free burning hydrogen) was noted drifting upward to the base heat shield, vertical stabilizer, and under the body flap on cameras E-5 and E-17.

Two rectangular, flexible pieces of debris were seen moving left to right across the field of view on cameras E-16 (frame 4750) and E-18 (frame 4630). KSC stated that the debris may be pieces of purge barrier (baggie) tape.

On cameras E-2, E-16, E-18, and E-20, pieces of burning debris (RCS paper covers) were noted falling through the field of view. Burning RCS paper has been seen on previous missions and is a normal event.

Several oscillations (ET tip deflection or twang motion) were noted of the ET tip on camera E-79. ET tip deflection is a normal event and the deflection envelope of 55 inches (-Z=40 inches, +Z=15 inches) total displacement did not appear to be exceeded. KSC reported maximum deflection was approximately 14 inches in the -Z direction and 9 inches in the +Z direction.

On cameras E-60 and E-64 the engine purge deluge water spray coverage of the LH₂/LO₂ T-0 umbilical disconnects did not appear to be the same for the LO₂ side (E-64) as it was for the LH₂ side (E-60). It was noted on camera E-64 that one water spray nozzle appeared to be angled too low to provide the proper water spray coverage. A facility check by KSC personnel determined that due to an alignment problem with a FIREX nozzle, no water reached the LO₂ ET/ORB umbilical. Corrective action was taken for the STS-56 launch.

Other normal events reported on previous missions and observed for this aborted launch were ice debris from the ET/Orbiter umbilical, RCS paper debris, slight body flap motion and slight TPS erosion on the base heat shield, during SSME start-up.

The second launch attempt of the STS-55 mission was successful and occurred on April 26, 1993.

Extensive photographic and video coverage was provided and has been evaluated to determine ground and flight performance. Cameras (cine and video) providing this coverage are located on the Launch Complex 39A Fixed Service Structure (FSS), Mobile Launch Platform (MLP), various perimeter sites, and uprange and downrange tracking sites for the STS-55 launch conducted on April 26, 1993, at approximately 7:50 a.m. (PDT) from the Kennedy Space Center (KSC) and for the landing on May 6, 1993 at Edward Airforce Base (7:30 a.m. PDT).

Rockwell received launch films from 83 cameras (59 cine, 24 video) and landing films from 12 cameras (6 cine, 6 video) to support the STS-55 photographic evaluation effort.

All ground camera coverage for this mission including coverage on the MLP, FSS and tracking cameras were good.

Overall, the films showed STS-55 to be a clean flight. Several pieces of ice from the ET/ORB umbilicals were shaken loose at SSME ignition, but no damage to the Orbiter Thermal Protection System (TPS) was apparent. The usual condensation and water vapors were seen at the ET aft dome and the SRB stiffener rings and dissipated after the completion of the roll maneuver. Vapor was observed originating from the drain hole on the aft edge of the rudder/speed brake at liftoff. Charring of the ET aft dome and recirculation and brightening of the SRB plumes were visible and normal. Booster Separation Motor (BSM) firing and SRB separation also appeared to be normal, although clouds hampered the analysis of many of the longrange tracking cameras.

Nominal performance was seen for the MLP and FSS hardware. FSS deluge water was activated prior to SSME ignition and the MLP rainbirds were activated at approximately 1 second Mission Elapsed Time (MET), as is normal. All blast deflection shields closed prior to direct SRB exhaust plume impingement. Both TSM umbilicals released and retracted as designed. The ET GH_2 vent line carrier dropped normally and latched securely with no rebound. No anomalies were identified with the ET/ORB LH_2 umbilical hydrogen dispersal system hardware.

STS-55 was the fifteenth flight with the optimized attach link in the SRB holddown support post Debris Containment Systems (DCS's). The link is designed to increase the plunger velocity and seating accuracy, while leaving the holddown bolt ejection velocity unchanged. This prevents frangible nut fragments and/or NSI cartridges from falling from the DCS, while not increasing the probability of a holddown bolt hang-up.

No major or significant events were observed or identified. One item that merits mentioning (not considered an anomaly) is the white flash from SSME#2 at liftoff. This event and other events noted by the Rockwell film/video users during the review and analysis of the STS-55 photographic items are summarized in the following comments. These events are not considered to be a constraint to next flight.

COMMENTS

1. On cameras E-2, E-3, and E-20, a white flash was noted in the SSME #2 plume at liftoff. Flashes have been observed on previous missions and are probably caused by small amounts of contaminants in the main engine. No follow-up action is planned.
2. Orange vapor (possibly free burning hydrogen) was seen below the body flap just prior to SSME ignition on cameras OTV-063, E-1, E-3, E-5, E-17, E-19, E-20 and E-52. This vapor appears to be similar to the vapor noted on previous missions. It is not an issue and no follow-up action is planned.
3. On camera E-18, a rectangular piece of debris was seen in the left inboard elevon lower surface area falling aft prior to liftoff. Also, another rectangular piece of debris was seen falling from the LH_2 TSM umbilical area after umbilical disconnect. No follow-up action is planned.
4. Multiple pieces of white debris, probably ice from the ET/Orbiter umbilical area, were seen falling from behind the body flap into the SSME plume after liftoff on cameras E-52, E-76, and E-77. No follow-up action is planned.

5. On cameras E-30 and E-36, two dark debris objects (probably SRB throat plug RTV) appeared to be moving north out of the SRB flame duct. This debris did not appear to strike the vehicle. No follow-up action is planned.
6. Multiple pieces of debris particles were seen falling aft of the Orbiter after completion of the roll maneuver on cameras E-212, E-213, and E-222. The debris were traced to the forward RCS thrusters and were pieces of the RCS paper covers. No follow-up action is planned.
7. Flares and flashes seen in the SSME exhaust plume (KTV-4A, KTV-21A, E-52, E-76, E-212, E-213, E-218) during ascent. These observations have been seen in the SSME plumes on previous missions and are understood to be burning of propellant impurities including RCS paper covers. No follow-up action is planned.
8. The following events have been reported on previous missions and observed on STS-55. These are not of major concern, but are documented here for information only:
 - Ice debris falling from the ET/Orbiter Umbilical disconnect area.
 - Debris (Insta-foam, water trough) in the holddown post areas and MLP.
 - Charring of the ET aft dome.
 - ET aft dome outgassing after liftoff.
 - Butcher paper falling from the RCS.
 - Recirculation or expansion of burning gases at the aft end of the SLV prior to SRB separation.
 - Slight TPS erosion on the base heat shield during SSME start-up.
 - Twang motion.
 - Body flap motion during the maximum dynamic pressure (MAX-Q) region which appeared to have an amplitude and frequency similar to those of previous missions.
 - Linear optical distortion, possibly caused by shock waves or ambient meteorological conditions near the vehicle, during ascent.
 - Slag in SRB plume after separation.
 - Condensation around the SLV during ascent.
 - Vapor from the SRB stiffener rings after liftoff.
 - Fore-and aft movement of the Orbiter base heat shield in the centerline area between the SSME cluster at engine start-up.
9. Cameras E33 and E41 - OMRSD File IX Vol. 5, Requirement No. DV08P.010 requires an analysis of launch pad film data to verify that the initial ascent clearance separation between the left SRB outer mold line and the falling ET vent umbilical structure does not violate the acceptable margin of safety.

A qualitative assessment has been conducted and positive clearances between the left SRB and the ET vent umbilical have been verified. The films showed nominal launch pad hardware performance, and no anomalies were observed for the SRB body trajectory.

10. Cameras E7-16 and E27-E28 - OMRSD File IX Vol. 5, Requirement No. DV08P.020 requires an analysis of film data of SRM nozzle during liftoff to verify nozzle to holddown post drift clearance.

A qualitative assessment of the launch films has been completed. No anomalies were observed for the SRM nozzle trajectory and positive clearances between the SRB nozzles and the holddown posts were verified.

11. The landing of STS-55 occurred on the hard surface runway 22 at Edwards Air Force Base. Good video and film coverage were obtained and no anomalous events were observed. This flight marked the eighth use of the Orbiter drag chute. The drag parachute system performed as expected. All sequenced events occurred as expected and no hardware anomalies were observed.

During the post-landing inspection several tiles were damaged on the right aft edge of the vertical stabilizer stinger. This area has sustained damage on previous uses of the drag chute by contact with the parachute riser lines. No follow-up action has been requested.

This letter is of particular interest to Messers W. J. Gaylor (VF2) and C. F. Martin (MK-SIO-2) at NASA/JSC and NASA/KSC respectively. The Integration Contractor contact is R. Ramon at (310) 922-3679.

ROCKWELL INTERNATIONAL
Space Systems Division

B. E. Andrews
FOR J. A. Wolfelt
Chief Engineer
System Integration

RR/ly

cc: G. Della Longa, BC4, NASA/JSC, Houston, Tx
W. J. Gaylor, VF2, NASA/JSC, Houston, Tx
H. S. Brown, MK-SIO-2, NASA/KSC, Kennedy Space Center, Fl
D. Pitts, SN15, NASA/JSC, Houston, Tx
G. Katnik, TV-MSD-22, NASA/KSC, Kennedy Space Center, Fl
B. Hoover, BICO-1, NASA/KSC, Kennedy Space Center, Fl
T. Rieckhoff, EP55, NASA/MSFC, Huntsville, Al
Addressee
NASA/JSC Mail Center
(Complete external distribution made via Data Management Systems)

KSC DEBRIS/ICE/TPS ASSESSMENT AND INTEGRATED PHOTOGRAPHIC
ANALYSIS REPORT DISTRIBUTION LIST 1/93

NASA - KSC

MK/B. Shaw
TV-PEO-2/P. Weber
TV-MSD-1/C. Stevenson
TV-MSD-2/L. Bolton
TV-MSD-22/G. Katnik (9)
TE-CID-2/C. Brown
TE-CID-21A/N. Pope
RO/R. E. Reyes
MK-SIO-2/C. Martin

GK-5/Z. H. Byrns
SK/F. Huneidi
ZK-88/K. J. Mayer
LSO-178/H. L. Lamberth
LSO-437/J. Cawby
USBI-LSS/L. Clark
BICO-1/R. B. Hoover

NASA - HQ

QSO/W. Comer

NASA - JSC

VA/D. Germany
ES3/J. Kowal
SN3/E. Christiansen
SN5/D. E. Pitts

Johnson Space Center
Houston, Texas 77058

NASA - MSFC

ED35/D. Andrews
EE31/M. A. Pessin
EP55/T. J. Rieckhoff
SA32/J. G. Cavalaris
SA31/G. C. Ladner

Marshall Space Flight
Center
Huntsville, AL 35812

Rockwell - Downey

AC07/J. McClymonds
FA44/R. Ramon

Rockwell International
12214 Lakewood Blvd
Downey, CA 90241

Martin Marietta

Dept. 3571/S. Copsey
Dept. 3570/C. Gray

13800 Old Gentilly Road
New Orleans, Louisiana
70129
P. O. Box 29304
New Orleans, Louisiana
70189

REPORT DOCUMENTATION PAGE

Form Approved
OMB No. 0704-0188

Public reporting burden for this collection of information is estimated to average 1 hour per response, including the time for reviewing instructions, searching existing data sources, gathering and maintaining the data needed, and completing and reviewing the collection of information. Send comments regarding this burden estimate or any other aspect of this collection of information, including suggestions for reducing this burden, to Washington Headquarters Services, Directorate for Information Operations and Reports, 1215 Jefferson Davis Highway, Suite 1204, Arlington, VA 22202-4302, and to the Office of Management and Budget, Paperwork Reduction Project (0704-0188), Washington, DC 20503.

1. AGENCY USE ONLY (Leave blank)	2. REPORT DATE May 1993	3. REPORT TYPE AND DATES COVERED Final 22 March - 7 May 1993
----------------------------------	----------------------------	---

4. TITLE AND SUBTITLE Debris/Ice/TPS Assessment and Integrated Photographic Analysis of Shuttle Mission STS-55	5. FUNDING NUMBERS
---	--------------------

6. AUTHOR(S) Gregory N. Katnik Barry C. Bowen J. Bradley Davis	
---	--

7. PERFORMING ORGANIZATION NAME(S) AND ADDRESS(ES) NASA External Tank Mechanical Systems Division Mail Code: TV-MSD-22 Kennedy Space Center, Florida 32899	8. PERFORMING ORGANIZATION REPORT NUMBER TM 107559
---	---

9. SPONSORING/MONITORING AGENCY NAME(S) AND ADDRESS(ES)	10. SPONSORING/MONITORING AGENCY REPORT NUMBER
---	--

11. SUPPLEMENTARY NOTES

12a. DISTRIBUTION/AVAILABILITY STATEMENT Publicly Available Unclassified - Unlimited	12b. DISTRIBUTION CODE
--	------------------------

13. ABSTRACT (Maximum 200 words)

A Debris/Ice/TPS assessment and integrated photographic analysis was conducted for Shuttle mission STS-55. Debris inspections of the flight elements and launch pad were performed before and after launch. Ice/Frost conditions on the External Tank were assessed by the use of computer programs, nomographs, and infrared scanner data during cryogenic loading of the vehicle followed by on-pad visual inspection. High speed photography was analyzed after launch to identify ice/debris sources and evaluate potential vehicle damage and/or in-flight anomalies. This report documents the debris/ice/TPS conditions and integrated photographic analysis of Shuttle mission STS-55, and the resulting effect on the Space Shuttle Program.

14. SUBJECT TERMS STS-55 Ice Frost Debris Thermal Protection System (TPS) Photographic Analysis	15. NUMBER OF PAGES
	16. PRICE CODE

17. SECURITY CLASSIFICATION OF REPORT Unclassified	18. SECURITY CLASSIFICATION OF THIS PAGE Unclassified	19. SECURITY CLASSIFICATION OF ABSTRACT Unclassified	20. LIMITATION OF ABSTRACT Unlimited
---	--	---	---