

DEVELOPMENT AND APPLICATION OF A 3-D
GEOMETRY/MASS MODEL FOR LDEF
SATELLITE IONIZING RADIATION ASSESSMENTS*

B. L. Colborn and T. W. Armstrong
Science Applications International Corporation
Route 2, Prospect, TN 38477
Phone: 615/468-2603, Fax: 615/468-2676

SUMMARY

A three-dimensional geometry and mass model of the LDEF spacecraft and experiment trays has been developed for use in predictions and data interpretation related to ionizing radiation measurements. The modeling approach, level of detail incorporated, example models for specific experiments and radiation dosimeters, and example applications of the model are described.

INTRODUCTION

Measurements of the ionizing radiation and effects on the Long Duration Exposure Facility (LDEF) satellite provide new data important to attaining a more accurate definition of the space radiation environment. An important issue in interpreting the LDEF radiation dosimetry data, and in performing definitive predictions to compare with the data, is the influence of material shielding effects. For example, data for the absorbed dose from geomagnetically trapped protons indicate a strong anisotropy for measurements made at different locations on LDEF (ref. 1), and measured LET (linear energy transfer) spectra from galactic cosmic rays also exhibit a directional response (ref. 2). A question in interpreting these results is to what extent this angular response is due to the directionality of the space radiation environment, which would be common to other spacecraft having orbit parameters similar to LDEF, as opposed to the influence of shielding variations particular to the LDEF experiment/spacecraft configuration.

The purpose of the present work is to provide a geometry and mass model of LDEF incorporating sufficient detail that it can be applied in determining the influence of material shielding on ionizing radiation measurements and predictions. The model can be utilized as an aid in data interpretation by "unfolding" shielding effects from the LDEF radiation dosimeter responses.

*Work supported by NASA Marshall Space Flight Center, Huntsville, AL, Contracts NAS8-38121 and NAS8-39386.

MODELING APPROACH

Initial work on the development of a LDEF geometry/mass model, which included the spacecraft structure and individual experiment trays but provide no detailed modeling of the tray contents, has been reported earlier (ref. 3). The model has now been extended to include a detailed description of the contents of several trays (F2, F8, H3, and H12).

The rationale of this tray selection for detailed modeling is as follows: Tray F2 (containing Exps. P0004 and P0006) and Tray F8 (containing Exp. M0004) are located near the trailing and leading edges of LDEF, respectively, and contain radiation dosimeters important to assessing the directionality of the trapped proton exposure (ref. 1). Furthermore, other measurements from the P0006 experiment in Tray F2 show a directional dependence of the spectra from heavy ions in galactic cosmic rays (ref. 2), and shielding variations around this experiment are needed in interpreting the data. Preliminary data from Exp. M0001 in Trays H3 and H12 indicate a higher heavy ion flux than expected entering the detector from the direction of the interior of the LDEF spacecraft (ref. 4), and the influence of shielding on relating the observed ion spectra to the incident space spectra is of interest in interpreting these data.

Methodology

The LDEF geometry/mass model has been programmed in FORTRAN using the combinatorial geometry methodology of describing complex three-dimensional configurations. The computer version of the geometry module used here has been operated for many years in radiation transport applications, and is the geometry module commonly used with the HETC radiation transport code (ref. 5).

The combinatorial geometry method describes three-dimensional material configurations by applying logical operators to form unions, differences, and intersections in combining simple solid bodies (spheres, boxes, cylinders, etc.) to form a complex geometry. Material properties are assigned to each zone defined by these operators, and ray-tracing algorithms are included to provide the pathlength and material identifier for each zone traversed. This material identifier is used as an index to retrieve information (density, atomic compositions, etc.) from a materials properties table. As an aid in debugging, we have used the SABRINA code (ref. 6) to obtain a graphical output of the geometry input data.

Input Data Sources

Input data for constructing the LDEF model has been obtained from engineering drawings, preflight reports from experimenters describing component layouts, dimensions, and materials for individual

experiments, and pre- and post-flight photographs, all kindly provided by the LDEF Project Science Office.¹ Key modeling input was the weight of individual experiment trays and all spacecraft structural components provided by NASA LaRC from pre-flight center-of-mass and flight dynamics analyses.² Dimensions for the experiment trays and descriptions of certain electronics and data storage components common to various experiments were obtained from the LDEF Experimenter Users Handbook (ref. 7). General descriptions and photographs of individual experiments from Clark, et al. (ref. 8) were also helpful.

Information needed for the detailed modeling of Exps. P0004, P0006, and M0004 was provided by Benton and Frank,³ and a detailed description of Exp. M0001 was provided by Tylka and Adams.⁴

Level of Detail Incorporated

The LDEF spacecraft is considered to be comprised of the following general categories for modeling purposes: spacecraft structure, miscellaneous spacecraft components, and experiments, which include the experiment trays and components (Tables I-III). The 84 experiment trays on LDEF can be further divided into four subcategories: (a) space debris experiments (26 trays), for which the tray contents can be adequately modeled as an aluminum plate; (b) ultra-heavy cosmic ray experiments (16 trays), for which the contents can be simply modeled as aluminum plus plastic; (c) trays containing ionizing radiation dosimeters (13 trays), for which some detailed modeling of the tray components is desirable, and (d) all other experiments (29 trays), for which the tray is considered to be filled with aluminum having a reduced density such that the individual tray weight is preserved. Thus, each individual experiment tray is modeled, with the actual weights of the trays and contents included, but only the contents of selected trays are modeled in detail for assessing shielding effects on the radiation dosimeter responses. Of the 13 trays indicated in Table III as containing ionizing radiation dosimetry, four trays (F2, F8, H3 and H12) are modeled in detail.

Experiment Models

Some of the geometry models of the LDEF ionizing radiation experiments are shown here as examples; other models and details of the modeling procedure are given in ref. 9. Fig. 1 shows a view of the LDEF spacecraft model with experiment trays, including the four experiment trays in which the contents are modeled in detail.

Fig. 2 shows the component layout in tray F2 and the corresponding combinatorial geometry model. This tray contains the six canisters of tomato seeds (SEEDS experiment) with the thermoluminescent

dosimeters (TLDs) of Exp. P0004 for measuring radiation dose at various positions in the seed canisters. This tray also contains the Exp. P0006 detector stack, which includes several types of radiation detectors: TLDs, plastic nuclear track detectors (PNTDs), activation materials, and neutron detection foils. The Exp. P0006 detector model is shown in more detail in Fig. 3.

The layout and geometry model of tray F8 containing Exp. M0004 on space environment effects on fiber optics is shown in Fig. 4. This tray contains two radiation dosimetry packets in each of two canisters, with each packet containing both TLDs and PNTDs.

The modeling assumptions for these and other trays in terms of geometry and material simplifications are detailed in ref. 9.

APPLICATIONS

The LDEF geometry module program can be applied in several operational modes: (a) as a stand-alone program, material thicknesses along rays emanating from specified spatial points and a specified angular grid can be generated to provide three-dimensional shielding variations around various dosimetry components; (b) such shielding distributions can also be used as input to one-dimensional transport codes which use solid angle sectoring to approximate three-dimensional radiation transport; and (c) the geometry module can be interface with detailed three-dimensional Monte Carlo radiation transport codes (e.g., HETC).

The geometry/mass model is currently being utilized in several studies related to predictions and comparisons with LDEF radiation dosimetry data and in the interpretation of LDEF radiation measurements. The model has been used with radiation transport calculations to predict the directionality of the radiation dose measured on LDEF (ref. 10), which showed that 3-D shielding effects were very important in comparing with the dosimetry data, and the model has been used by NRL⁴ in analyzing results from the Exp. M0001 heavy ion experiment.

Shielding calculations using the LDEF geometry/mass model are also being made to investigate the directionality of protons and heavy ions observed (ref. 2) in Exp. P0006 plastic nuclear track detectors. An example model application (stand-alone mode) is given in Fig. 5, which shows the shielding distribution in a horizontal plane around one of the PNTD side modules of Exp. P0006. Here a local coordinate system is used with the angle α measured in a plane parallel to the tray top. The "dips" in the shielding distribution designated as (a), (b), and (c) occur for directions between the seed canisters, with the large peak in the distribution (d) corresponding to directions going through lower trays (toward earth-end) and through the center ring of the spacecraft structure. The other P0006 side modules see a similar horizontal shielding

distribution but displaced by 90°. Such shielding variations can have an important influence on the observed radiation environment.

REFERENCES

1. Frank, A. L.; Benton, E. V.; Armstrong, T. W. and Colborn, B. L.: Absorbed Dose Measurements and Predictions on LDEF. Second LDEF Post-Retrieval Symposium, NASA CP-3194, 1993.
2. Csige, I.; Benton, E. V.; Frigo, L.; Parnell, T. A.; Watts, J. W. Jr.; Armstrong, T. W. and Colborn, B. L.: Three Dimensional Shielding Effects on Charged Particle Fluences Measured in the P0006 Experiment on LDEF. Second LDEF Post-Retrieval Symposium, NASA CP-3194, 1993.
3. Colborn, B. L. and Armstrong, T. W.: LDEF Geometry/Mass Model for Radiation Analyses. First LDEF Post-Retrieval Symposium, NASA CP-3134, 1992.
4. Adams, James H. Jr.; Beahm, Lorraine P. and Tylka, Allan J.: Preliminary Results from the Heavy Ions in Space Experiment. First LDEF Post-Retrieval Symposium, NASA CP- 3134, 1992.
5. Armstrong, T. W. and Colborn, B. L.: HETC/LHI, A Thick Target Radiation Transport Code for Low-Mass Heavy Ions Beams. *Nucl. Instr. Meth.* 169, 161 (1980).
6. West, James T.: SABRINA: An Interactive Three-Dimensional Geometry-Modeling Program for MCNP. Los Alamos National Laboratory, LA-10688-M, October 1986.
7. Long Duration Exposure Facility (LDEF) Experimenter Users Handbook, LDEF Project Office Report No. 840-2 (Change No. 3), NASA Langley Research Center, October 3, 1980.
8. Clark, Lenwood G.; Kinard, William H.; Carter, David J. Jr. and Jones, James L. (Eds): The Long Duration Exposure Facility (LDEF): Mission 1 Experiments, NASA SP-473, 1984.
9. Colborn, B. L. and Armstrong, T. W.: Geometry and Mass Model of Ionizing Radiation Experiments on the LDEF Satellite. Science Applications International Corporation (NASA MSFC Contract NAS8-39121 Final Report), SAIC-TN-9202, April 1992.
10. Armstrong, T. W., and Colborn, B. L.: Radiation Model Predictions and Validation Using LDEF Satellite Data. Second LDEF Post-Retrieval Symposium, NASA CP-3194, 1993.

Footnotes

1. Jones, J., LDEF Project Science Office, NASA Langley Research Center, pri. comm., 1991.
2. Shearer, R., NASA Langley Research Center, pri. comm., 1991.
3. Benton, E. V. and Frank, A. L., University of San Francisco, pri. comm., 1992.
4. Adams, J. H., Jr. and Tylka, A. J., Naval Research Laboratory, pri. comm., 1992.

Table I. Level of Detail for Modeling LDEF Spacecraft

Category	Component	No. Places	Weight (lbs.)	Weight %	Modeling Approach
STRUCTURE	Center Ring	1	2,073	9.7%	Modeled as individual component.
	Longerons	24	2,280	10.7%	Modeled as individual components.
	End Frames	2	1,374	6.4%	Modeled as individual components.
	Diagonal Tubes	8	926	4.3%	Modeled as individual components.
	Intercostal Rings	72	758	3.5%	Modeled as individual components.
	Trunions, Pins, Scuff Pits	10	501	2.3%	Modeled as individual components.
	End Support Beams	5	285	1.3%	Modeled as individual components.
TOTAL STRUCTURE:			8,197	38.3%	
MISCELLANEOUS	Batteries	2	100	0.5%	Included as part of earth-end support beam.
	Initiate Electronics	1	105	0.5%	Included as part of center ring weight.
	Wiring	-	100	0.5%	Included as part of center ring weight.
	Nuts and Bolts	-	200	0.9%	Included as part of center ring weight.
	Damper Assembly	1	62	0.3%	Modeled as individual component.
	Thermal Covers (Ends)	12	154	0.7%	Modeled as individual components.
	Ballast Plates	11	365	1.7%	Included as part of end frames.
TOTAL MISCELLANEOUS:			1,086	5.1%	
EXPERI-MENTS	Experiment Components and Trays	84	12,110	56.6%	Modeled each experiment tray separately, with individual experiment weights preserved. Modeling for components varies with experiment type.
TOTAL LDEF WEIGHT:			21,393	100.0%	

Table II. Level of Detail for Modeling Experiments

No. Trays	Model	Experiments
26	Al plate	S0001: Space Debris (LaRC)
16	Al+plastic plates	A0178: Ultra-heavy Cosmic-Ray Expt. (Dublin Inst., ESTEC)
13	"detailed"	Selected experiments containing ionizing radiation dosimetry.
29	homogenized Al	(all others)

Table III. Trays Containing Ionizing Radiation Dosimetry

Tray Bay-Row	Experiment No.	Experiment	Dosimetry
C-2, G-2	A-0015	Biostack (DFVLR)	TLD's, PNTD's
C-3, C-9	A-0114	Atomic Oxygen (UAH, MSFC)	Activation Samples
B-3	A-0138	Optical Fibers (CERT/ONERA - DERTS)	TLD'S
H-3, H-12	M0001	Heavy Ions (NRL)	PNTD's
D-3, D-9, G-12	M0002-1	Trapped Proton Spect. (AFGPL, MSFC, et al.)	PNTD's, TLD's, Act.
E-6	M0002-2	Heavy Cosmic-Ray Nuclei (U. Keil)	PNTD's
D-3, D-8, D-9	M0003	Space Env. Effects on Mats. (Aerospace)	TLD's
F-8	M0004	Space Env. Effects on Optics (AFWL)	TLD's, PNTD's
C-2	M0006	Space Env. Effects (AFTAC, Grumman)	TLD's
F-2	P0004	SEEDS (Univ. SF)	TLD's, PNTD's
F-2	P0006	LET Spectrum Meas. (Univ. SF, MSFC)	TLD's, PNTD's, Fiss. & Act. Samples

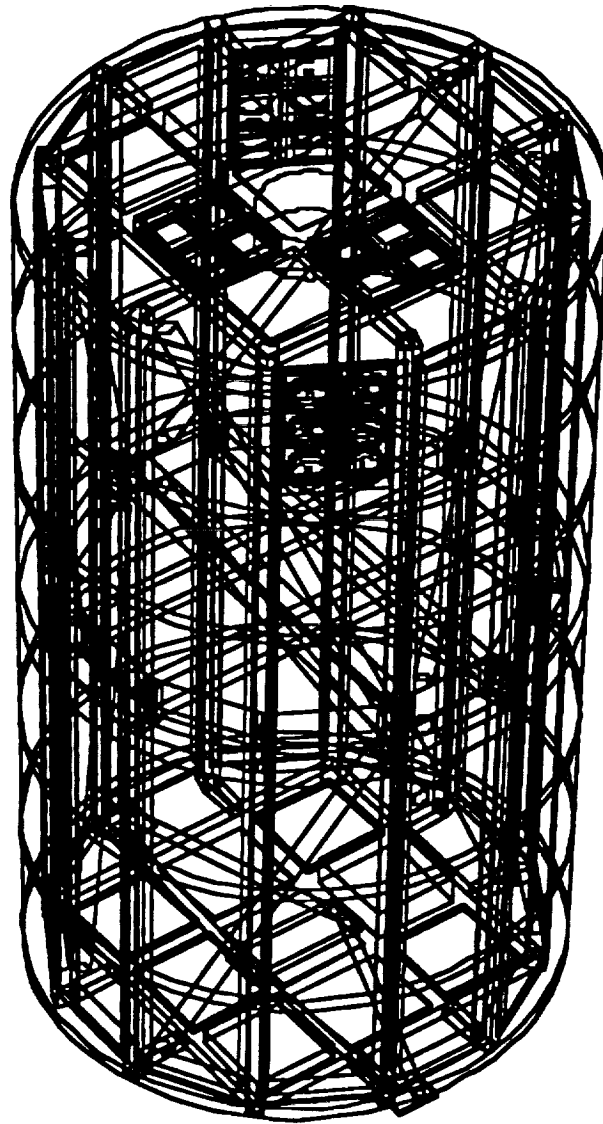

Figure 1. Combinatorial geometry model of LDEF spacecraft with the four experiment trays (F2, F8, H3, and H12) containing radiation dosimeters which have been modeled in detail.

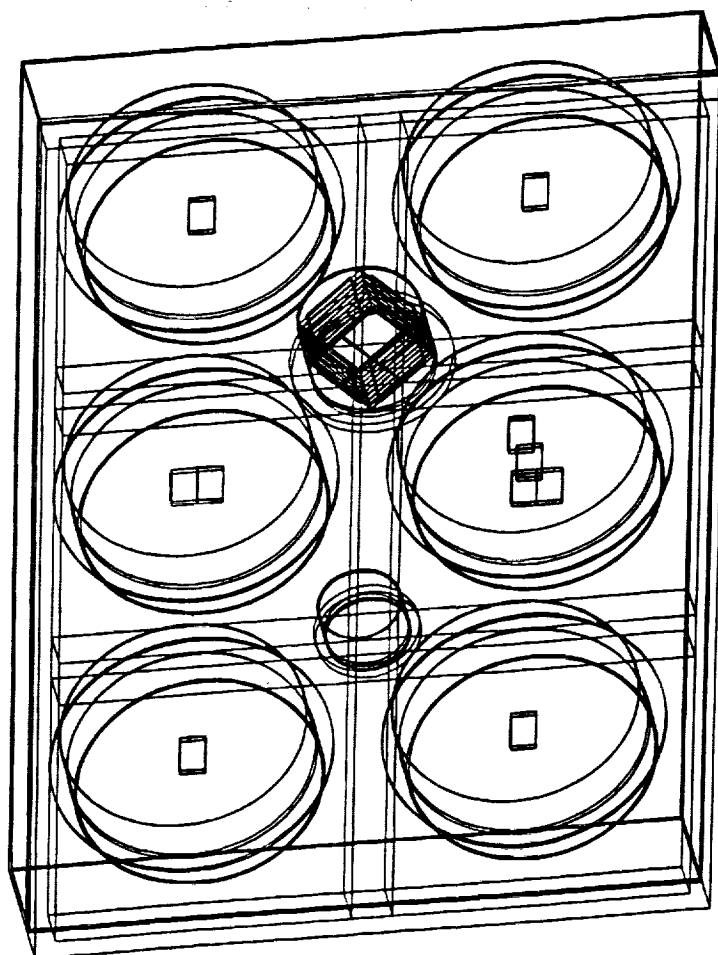
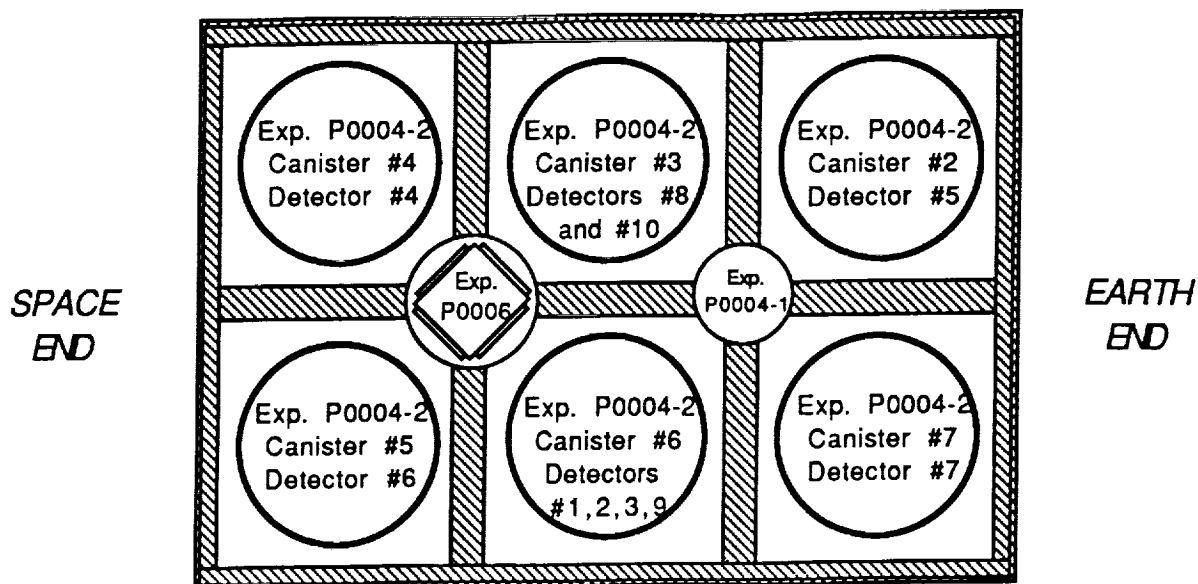

Figure 2. Layout of components in LDEF experiment tray F2 containing radiation dosimetry (top) and combinatorial geometry model (bottom), showing TLD packets (Exp. P0004) in the seed canisters and the Exp. P0006 detector stack.

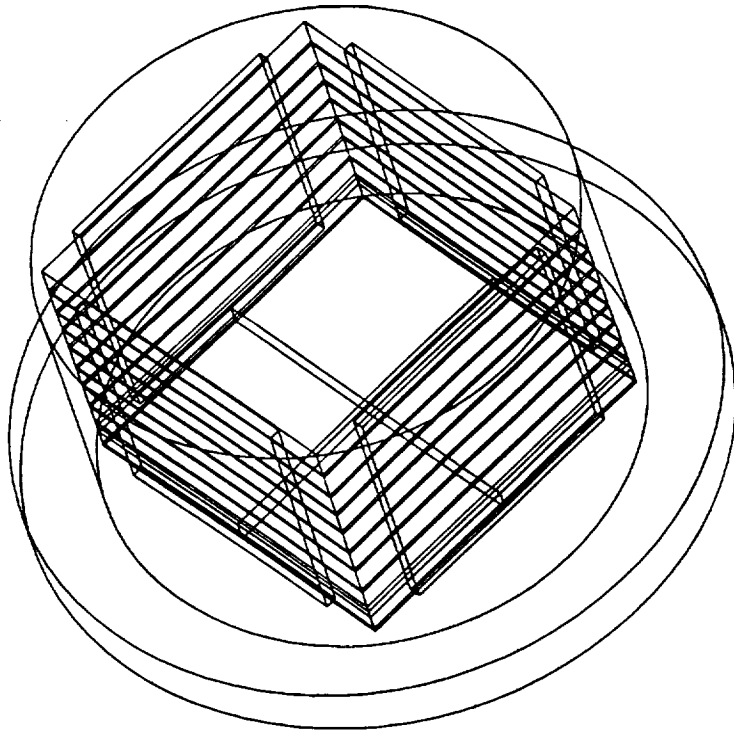
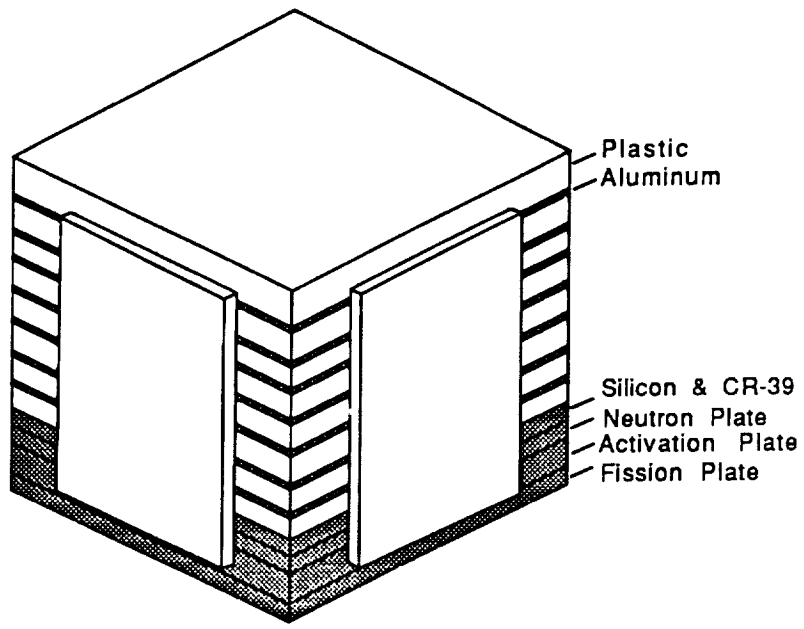

Figure 3. Material layers modeled in the Exp. P0006 detector stack (top) and corresponding combinatorial geometry model of detector and canisters (bottom).

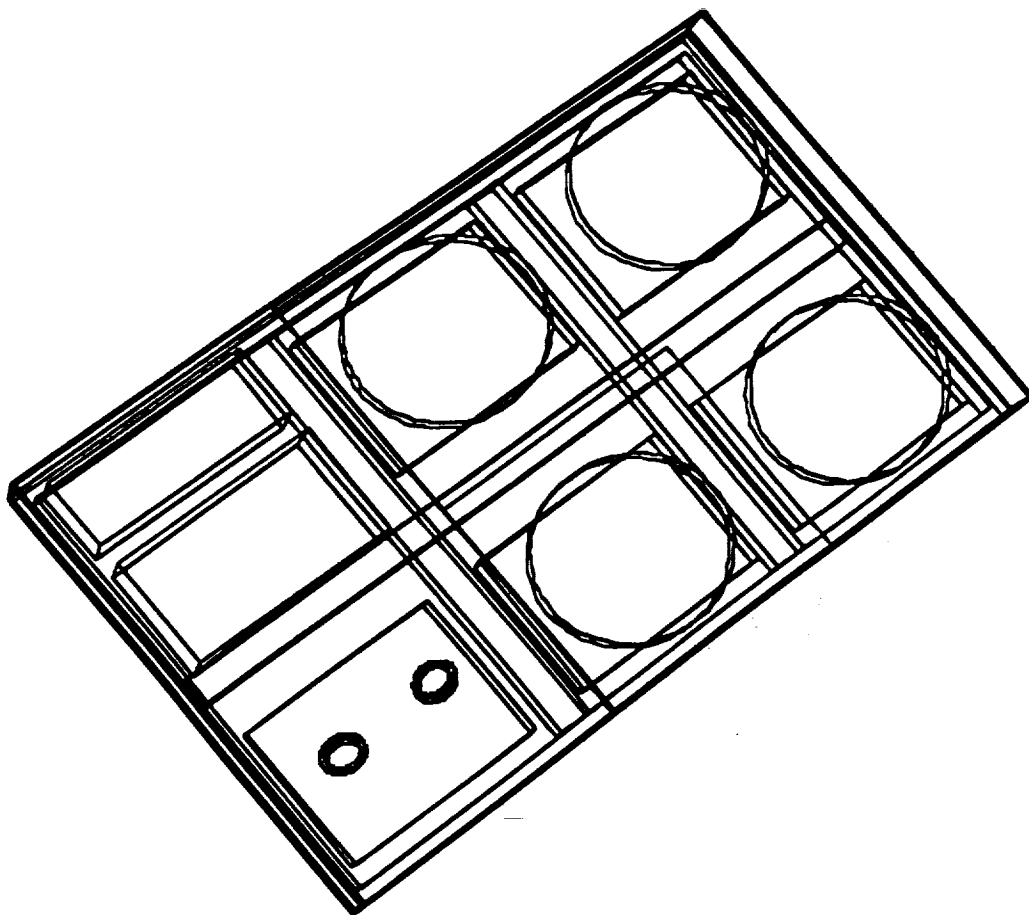
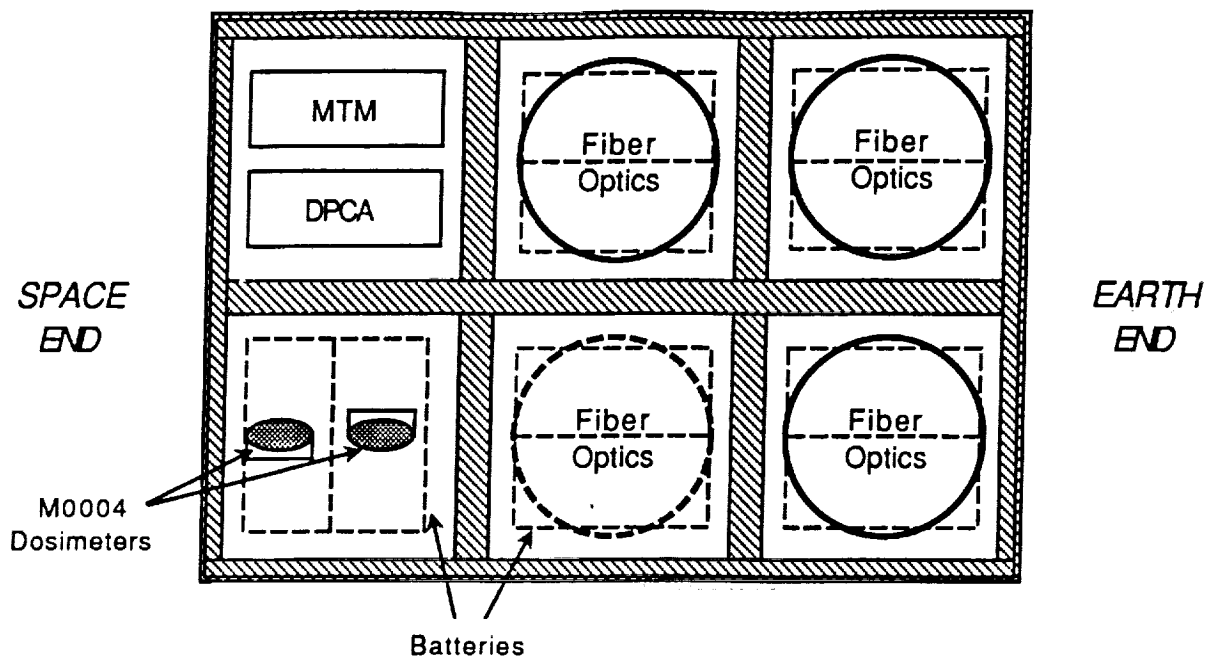

Figure 4. Layout of LDEF tray F8 containing Exp. M0004 radiation dosimeters (top) and corresponding geometry model (bottom).

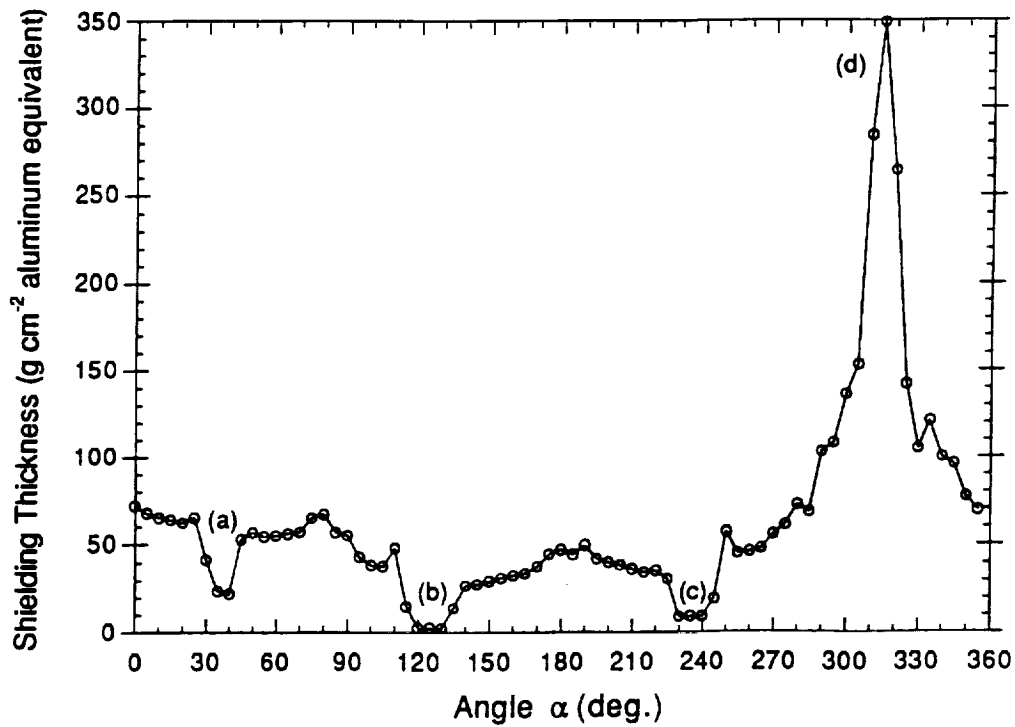
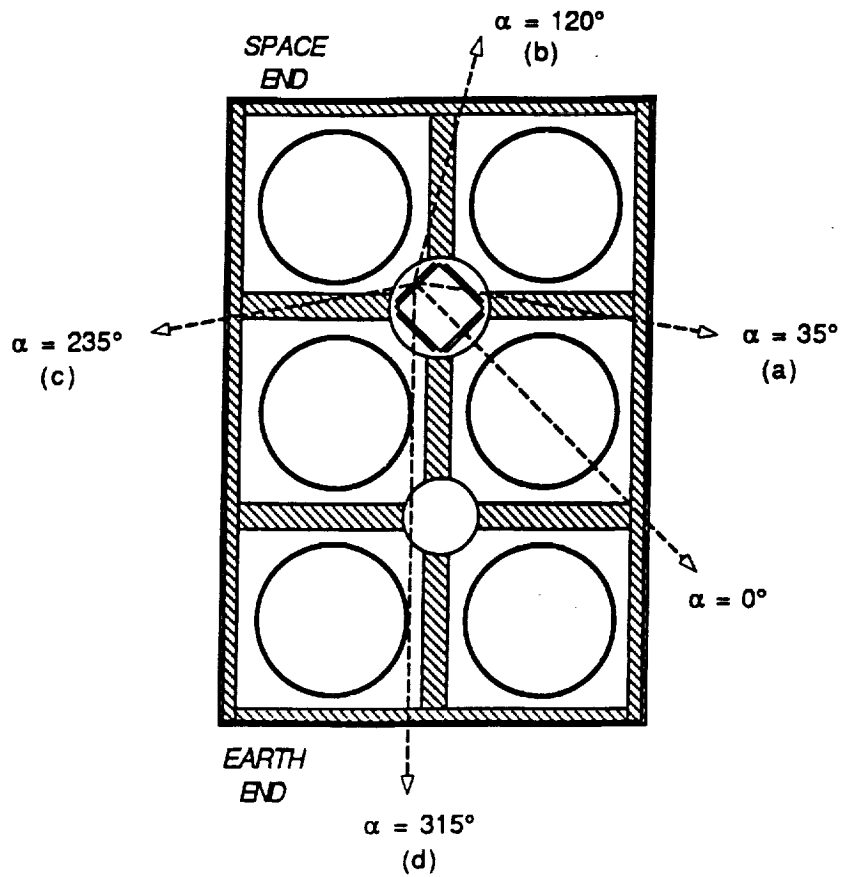

Figure 5. Shielding distribution in horizontal plane for a point on the surface of the detector module of Exp. P0006.

