

**DELTA ADVANCED REUSABLE TRANSPORT (DART)
AN ALTERNATIVE MANNED SPACECRAFT**

UNIVERSITY OF MARYLAND

S23-18
160599
P. 11

INTRODUCTION

Although the current U.S. Space Transportation System (STS) has proven successful in many applications, the truth remains that the space shuttle is not as reliable or economical as was once hoped. In fact, the Augustine Commission on the future of the U.S. Space Program has recommended that the space shuttle only be used on missions directly requiring human capabilities on-orbit and that the shuttle program should eventually be phased out. This poses a great dilemma since the shuttle provides the only current or planned U.S. means for human access to space at the same time that NASA is building toward a permanent manned presence.

As a possible solution to this dilemma, it is proposed that the U.S. begin development of an Alternative Manned Spacecraft (AMS). This spacecraft would not only provide follow-on capability for maintaining human spaceflight, but would also provide redundancy and enhanced capability in the near future. Design requirements for the AMS studied here include:

- Capability of launching on one of the current or planned U.S. expendable launch vehicles (baseline McDonnell Douglas Delta II model 7920 expendable booster).
- Application to a wide variety of missions including autonomous operations, space station support, and access to orbits and inclinations beyond those of the space shuttle.
- Low enough costing to fly regularly in augmentation of space shuttle capabilities.
- Production surge capabilities to replace the shuttle if events require it.
- Intact abort capability in all flight regimes since the planned launch vehicles are not man-rated.
- Technology cut-off date of 1990.
- Initial operational capability in 1995.

In addition, the design of the AMS would take advantage of scientific advances made in the 20 years since the space shuttle was first conceived. These advances are in such technologies as composite materials, propulsion systems, avionics, and hyper-sonics.

DART AMS OVERVIEW

In response to the demonstrated need for an AMS, the Delta Advanced Reusable Transport (DART) was designed by students in the ENAE 412 Space Systems Engineering class at the University of Maryland. As seen in Fig. 1, the DART spacecraft design centers on a semiballistic capsule concept similar in many respects to

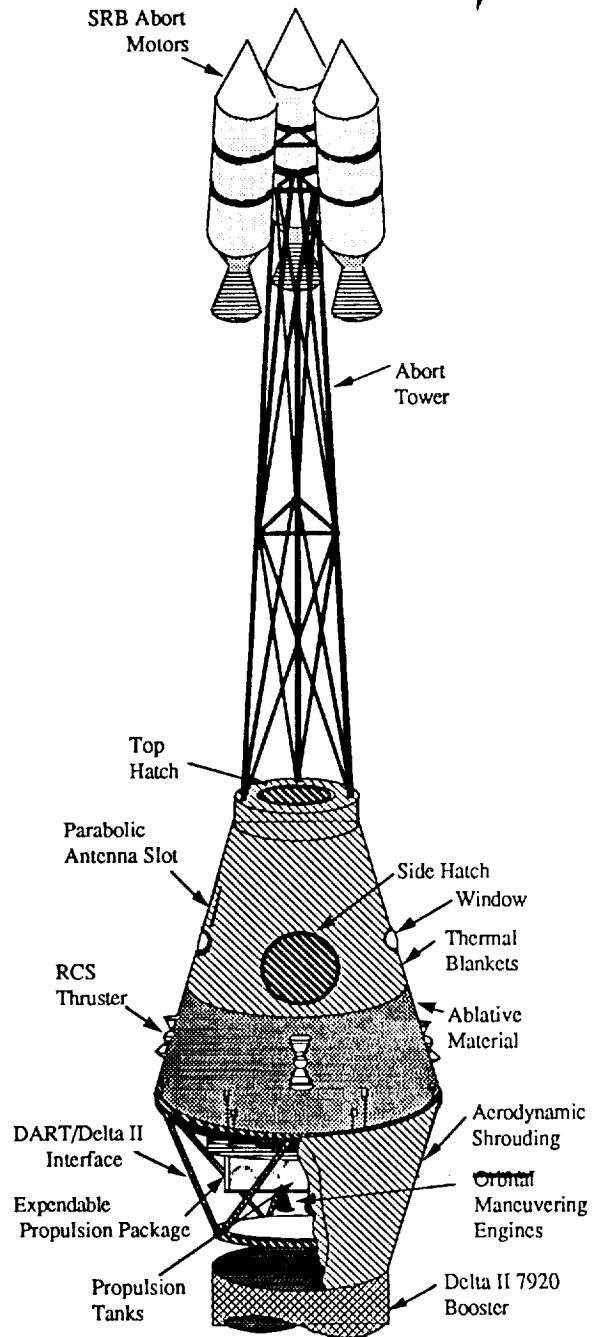

Fig. 1. DART AMS concept.

164 INTENTIONALLY BLANK

the U.S. manned spacecraft of the 1960s, but employing more advanced structures, propulsion, and avionics technologies. The proposed baseline design features are summarized in Table 1.

TABLE 1. DART baseline design features.

Mass	4772 kg at launch
Size	3.5 m diameter, 4.5 m length
Crew	2 to 5
Payload	52 to 292 kg
Mission Length	1 to 5 days
Recovery	Semiballistic reentry; parachute to ocean splashdown

With 96% reliability, the Delta rocket's launch program supplies the DART spacecraft with the cost-effective and readily available launch capabilities required of an AMS. This includes the use of existing launch facilities at Complex 17, Cape Canaveral Air Force Station (CCAFS), Florida. The 1990 technology cut-off date was imposed to both cut development and research costs, as well as to insure that the 1995 initial operation capability requirement is satisfied.

The DART spacecraft's mass and size constraints are defined by the Delta II's maximum payload mass capability for a designated orbit. DART's baseline mission is a low Earth orbit (LEO) satellite servicing operation, although a nominal orbit of 500 km and 28.5° inclination was chosen for calculation purposes to allow for space station capabilities. This 500 km orbit can be achieved with a maximum payload of 4824 kg. The DART mass breakdown is shown in Table 2.

TABLE 2. DART mass breakdown.

System	Subsystem	Mass (kg)
Structures	Main Structure	237
	Docking Module	28
	Thermal Protection System	318
	Abort Tower/Motors	195*
	Impact Attenuation System	129
	Parachutes	200
Systems	Interface	7*
Integration	Propulsion	3
Propulsion	Main Engines	136
	Main Propellant Tanks and Plumbing	80
	Reaction Control System	491
	Fuel	767
Avionics	Data Processing	96
	Attitude Sensors	10
	Sensors	150
	Radar	75
	Guidance and Navigation	29
	Communication	82
	Power Generation	131
Human Factors	ECLSS	634
	Food and Water	574
	5 Astronauts	400
Total		4,772

* Effective mass = 1/4 actual mass.

The DART capsule consists of an inner pressure vessel and an outer honeycomb structure, both constructed out of aluminum. In addition, a thermal protection system (TPS) utilizing

a combination of ablative material and thermal blankets is applied to the external surface of the capsule. The TPS maintains acceptable skin temperatures during all phases of the mission.

The AMS design requirements specify the necessity of intact abort capability in all flight regimes. During launch, an abort tower is attached to the top of the capsule and an aerodynamic shroud cover the DART/Delta II interface ring truss. The shroud and abort tower are jettisoned before reaching desired orbit. Situated within the ring truss is an expendable hypergolic propulsion system utilizing hydrazine and nitrogen tetroxide propellants; it is strapped onto the capsule and jettisoned during re-entry.

During a mission, the DART spacecraft will experience a variety of forces tending to rotate and/or translate the capsule. Thus, the DART is equipped with a reaction control system (RCS) to measure, correct, and counteract any adverse motion. In addition to the main engine and RCS propulsion systems, DART requires a power generation system. Solar cells provide the primary electrical power with rechargeable batteries as the secondary power source.

The DART avionics systems provide navigation, attitude control, data processing, sensors, and communications. The LTN-90 ring laser gyro inertial navigation system (INS) will serve as the primary attitude and position reference. A data processing system is required for navigation, attitude, and flight control computations. This system uses sensors to keep the astronauts informed about the status of all DART systems. Communications are needed for video and voice contact, navigation and rendezvous transmissions, and for conducting experiments. To insure reliable communications, two different paths have been chosen: one through the Tracking Data Relay Satellite System (TDRSS) and the other directly to Earth stations.

DART's manned-rating requires thorough investigation of human factors. The interior of the capsule will be held at standard atmospheric conditions with metabolic carbon dioxide removal by means of solid amine. Spacesuits are similar to those worn by shuttle astronauts. Food and water must be carried in full due to the large mass and volume requirements of a water recycling system.

Figure 2 details the internal layout of the DART AMS. Included are the dimensions of the habitation environment as well as controls and monitors needed during the mission. Note that there are three couches in addition to the pilot and copilot seats. These couches can be removed, allowing for two, three, four, or five crew members or payload and experiment lockers. Storage bins in the crew compartment will hold such items as tools, schedules, clothing, and personal items.

As stated in the overview, the baseline mission proposed for DART is a LEO satellite servicing operation. Three astronauts will be launched from the Kennedy Space Center (KSC) to a rendezvous orbit with the satellite requiring servicing. Microgravity experiments will be performed during the three-day Earth orbit wait period required for astronaut adaptation to the microgravity environment. The next phase of the mission involves an extravehicular activity (EVA) that could include routine satellite maintenance, component replacement, and repair. The mission duration varies from three to five days.

The DART spacecraft can be utilized as a "taxi," a "tug," or as an emergency escape vehicle for Space Station *Freedom*. The

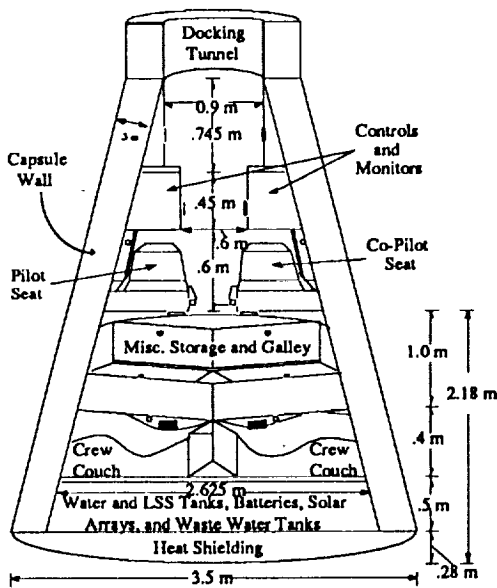

Fig. 2. DART AMS internal layout.

“taxi” concept entails the delivery of new astronauts to the space station and the return of current station personnel to Earth; as a “tug,” vital supplies will be delivered to *Freedom*. The length of these missions varies from one to three days. Should an emergency arise, evacuation may become necessary. Special DART spacecraft could be configured and ready at all times to provide an emergency “lifeboat vehicle” for station personnel.

In order to complete other missions, alternative launch vehicles such as the Atlas IIA and Titan III were considered. Assuming launch trajectories are approximately Hohmann transfers, the vis-viva equation was used to calculate the required launch ΔV s. Table 3 shows these ΔV s and maximum altitudes of the launch vehicles with the 4772-kg DART. The Titan III launch vehicle was found to hold the most possibilities for DART. The large ΔV allows for missions to very high inclinations and altitudes almost four times that attained with the Delta II.

TABLE 3. Alternative launch vehicle capabilities.

Launch Vehicle	ΔV with 4772-kg DART (m/s)	Max. Alt. with 4772-kg DART (km)
Delta II	9,314	500
Atlas IIA	9,558	1,000
Titan III	10,164	1,900

All the missions described require rendezvous capability—either with a satellite or the space station. Space Station *Freedom* was chosen as the baseline for the rendezvous analysis, although the equations can be applied to many other scenarios. The vis-viva equation was used to calculate necessary velocity changes for Hohmann transfers in the rendezvous sequence. The Clohessy-Wilshire equations⁽¹⁾ were solved for the final approach to the target vehicles. To account for in-flight deviations and errors due to navigation instrumentation, human error, or the Delta II launch vehicle, a rendezvous sequence was created.

This sequence utilizes specific points where corrective maneuvers will be made, so that a much slower and safer approach can be achieved.

A maneuver with the distance vector in x (termed an r -bar maneuver) was chosen for final approach to minimize exhaust plume impingement upon the target vehicle. To insure that the final approach is made slowly, a rule was implemented that no burns will be made over 1% of the distance from the vehicle to the target. Consequently, many short burns must be made, each with decreasing strength. At the onset of the final maneuver proximity operations, the DART spacecraft is 1000 m from its target. The rendezvous burn sequence is

- (1) 1000 m \geq 500 m
- (2) 500 m \geq 100 m
- (3) 100 m \geq 50 m
- (4) 50 m \geq 25 m
- (5) 25 m \geq 10 m
- (6) 10 m \geq 5 m
- (7) 5 m \geq 0.5 m

The Clohessy-Wilshire equations were used to solve for impulse velocity components and the time to complete each maneuver.

A 4-minute transfer was chosen for each of the maneuvers making the total final approach a 28-minute maneuver. Summing the ΔV s for the rendezvous and proximity operations, the total ΔV is approximately 20 m/s without a plane change maneuver, and 85 m/s with a 0.5° plane change correction. Allowing for in-flight deviations, a ΔV of 100 m/s is required for the orbital maneuvering system (OMS), which will perform the rendezvous sequence, and a ΔV of 6 m/s is required for the RCS engines, which will perform the final approach.

STRUCTURES

The main shell of the DART capsule is made from 5052 alloy aluminum honeycomb sandwich sections bonded together to form the external cone structure. Graphite epoxy hat-section stringers located 20° apart will serve as load frames. Using the symmetrical bending formula, the individual cross-sectional areas of the stringers were calculated (see Fig. 3). The shear flow of this external shell could then be determined with the results

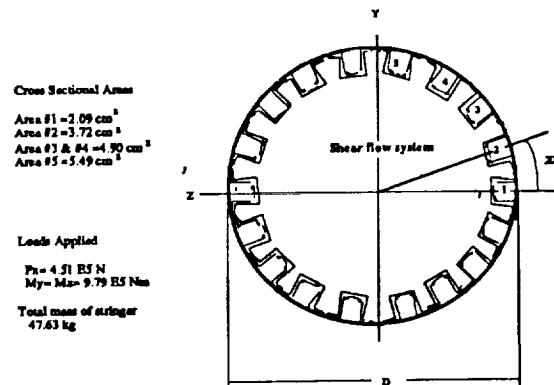

Fig. 3. Hat-section stringer attachment and cross-sectional areas.

shown in Fig. 4. Based on the maximum shear flow of $1.02E6$ N/m, the honeycomb facing thickness was calculated to be 0.119 cm. A core density of 354 kg/m^3 was chosen for the aluminum honeycomb because it provided the lowest mass able to withstand a maximum compressive stress of 37.3 MPa. The total mass of the external honeycomb shell is 192.73 kg, and the total mass of the stringers is 45.0 kg.

The inner pressure vessel was designed to maintain a pressure 0.1034 MPa greater than the outside pressure. Assuming a factor of safety of 1.5, the thickness of the pressure vessel was determined using the pressure cabin thickness equation⁽²⁾. 2024-T4 aluminum will be used for this wall due to the low stresses created by the internal pressure. Discussed later in the "Reentry Studies" section is the TPS that will be applied to the outer structural skin of the DART spacecraft.

An abort tower was designed for intact abort capability in all flight regimes. Three motors 120° apart and capable of 113.8 kN of thrust each, are located at the apex of the tower. A computer program was written to optimize the abort tower height with the angle of the solid rocket motors. The design is for the flow to impinge on the bottom of the capsule. The place where this impingement occurs will be protected by the TPS in order to provide a safe means of abort. The tower mass was assumed to be 5 kg/m. As the motor angle increases, so does the motor mass. An optimum gimbal angle of 8° with an abort tower height of 4.8 m was determined to provide the lowest mass for the abort tower/motor system.

A structural interface is required to integrate the DART capsule with its Delta II launch vehicle. A ring truss made of 6016-T6 aluminum alloy was designed (see Fig. 5) to hold the 4772-kg DART spacecraft statically stable under the maximum loadings

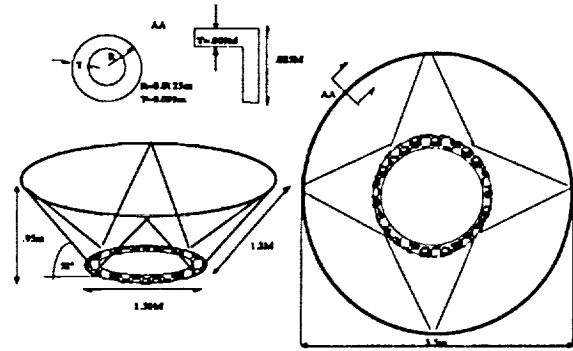

Fig. 5. DART/Delta II interface dimensions.

of the Delta II launch profile. Vibrational side loading will produce a maximum 0.7 gs along the lateral axis, and the longitudinal thrust axis will experience a maximum 5.86 gs during launch. Also, the interior volume of the truss must allow enough room for the strap-on propulsion package.

The DART capsule is secured to the truss by four steel cables. Applying the maximum loadings for the Delta II booster to the DART center of gravity, the ultimate force for the steel cables was found to be 22 kN. Using the method of sections and joints, and the definition of static stability, the forces in each member were isolated as a statically determinate system. The critical members were those on the 52° side angle; they bear a maximum force of 169.1 kN, which generates a maximum stress of 242 MPa. Using this value, a cross-sectional area of $7.0E-4 \text{ m}^2$ was obtained for the truss members. From the final dimensions and the minimum cross-sectional area, the volume of each member was calculated and summed over the entire structure. The total volume of the interface is 0.0107 m^3 , which produces a ring truss mass of 29 kg.

The DART strap-on propulsion package (shown in Fig. 1) is basically a box truss and ring fitting of 6016-T6 aluminum. The box forms a structural basket to hold the fuel, oxidizer, and pressurant tanks as well as necessary plumbing and regulators. The ring functions to diffuse the 17.8-kN force of the engines over an area of 0.178 m^2 . These conditions are acceptable to maintain heat shield and main structure integrity.

Each engine is connected to the cross members of the box truss using a conical cuff. These cuffs fit around the heat sink material used to cool the nozzle, and are secured with three arms bolted to the box truss. They hold the engine nozzles 5 cm apart to avoid nozzle impingement and are fastened together with 10 steel side bolts. Bolt stresses were found to be 185 MPa, requiring a cross-sectional bolt area of 4.51 mm^2 . The entire strap-on propulsion system is connected to the DART spacecraft with steel cables and is designed for a safety factor of 1.2.

PROPULSION AND POWER SYSTEMS

The requirements for the OMS of the DART spacecraft are reliability, low mass, and the capability of performing all necessary orbital maneuvers such as rendezvous and deorbit. The thrust required for reentry was determined by using the

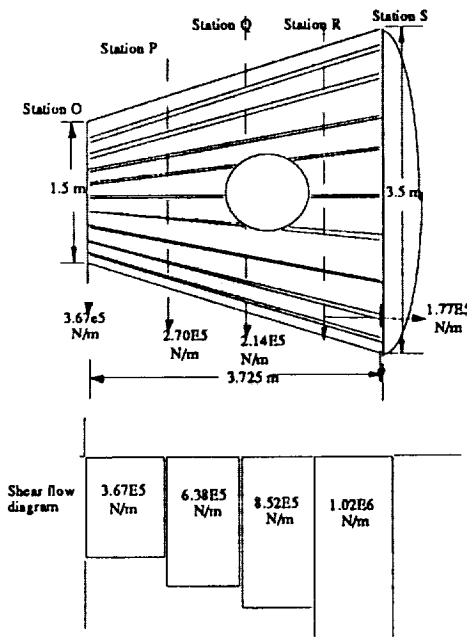

Fig. 4. Shear flow diagram.

re-entry ΔV and the time for the maneuver to be executed. The re-entry ΔV was found to be 240 m/s and the time for the maneuver was approximated as 1 min. This approximation was made so that there would be less than 1° of rotation about the Earth for the duration of the reentry burn, resulting in an impulsive maneuver. The required reentry thrust was found to be 18 kN.

Three major factors influenced the DART main engine propellant selection. Liquid propellants were chosen over solid propellants so that the OMS would be capable of several restarts. The second factor involved ignition systems. The two choices for ignition were to use a traditional ignition system or to use hypergolic propellants, which ignite on contact. Hypergolic propellants were chosen due to their low masses and simplicity. A trade-off study was undertaken to examine the properties and characteristics of several propellant combinations. The combination of hydrazine and nitrogen tetroxide was chosen due to ease of storage and more desirable physical characteristics.

The propellant feed system choice was made by examining two types of systems: pressure fed and turbopump fed. The turbopump system is a complicated one that provides high pressures for the chamber. Although the pressure-fed system delivers a lower pressure to the chamber (usually less than 5 MPa), it was chosen because the system has a minimal amount of moving parts, making it lighter, less expensive, and more reliable.

Because of volume constraints set by the DART/Delta II interface, a design configuration with four engines will be implemented. With four smaller engines (instead of one or two larger engines), the available volume can be maximized more easily. Having four engines also provides redundancy if one of the engines should fail. A bolt-on engine configuration was also developed for DART. However, the choice was made to use the strap-on engine system since it is entirely exterior to the spacecraft, leaving more room available for cabin use.

The optimum chamber pressure was determined by taking the minimum thrust required and determining the smallest exit diameter that is capable of providing that thrust. Results from this analysis are shown in Fig. 6, from which the smallest exit

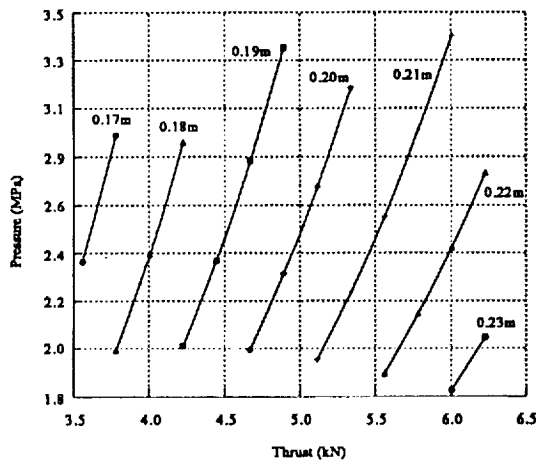

Fig. 6 Chamber Pressure vs. Thrust (Varying Exit Diameter)

diameter was found to be 19 cm. A thrust of 4.45 kN was used for this calculation. Applying this information, a computer program was written to determine the main engine specifications. Results from this analysis are summarized in Table 4. Figure 7 shows main engine dimensions.

TABLE 4. Main engine specifications.

Fuel	Hydrazine
Oxidizer	Nitrogen Tetroxide
Avg. Molecular Weight	19 kg/mol
Cp/Cv	1.26
Thrust/Engine	4.45 kN
I_{sp}	305.6 s
Flow Rate	1.48 kg/s
Nozzle Mass	28.6 kg
Chamber Mass	2.3 kg

Two different types of nozzles were compared for use in the main engine: bell and conical. The necessary length of the nozzle was determined to be 28.6 cm for the conical and 43.8 cm for the bell. The cost of the nozzles is also important since the engines are not reusable. The cost of constructing a conical nozzle is much less than the cost of manufacturing a bell nozzle. The main disadvantage of the conical nozzle is that there are more losses than in a bell. The losses, though, are small, and the conical nozzle was determined to be the best choice for the DART propulsion system.

When the engines are operated, they generate great amounts of heat. If the engine walls are not designed properly they will begin to melt and send particulates into the flow. The proper thickness of the wall was determined by using heat conduction equations. The thickness of the wall was determined to be 3.7 cm, tapering to 1.0 cm at the nozzle exit. The material that was used to make the walls into a heat sink was a high-grade nickel alloy. The masses of the nozzle and chamber were found to be 28.6 kg and 2.3 kg, respectively.

The engine performance of the DART spacecraft was mainly determined by the specific impulse (I_{sp}) of the OMS. A program was written to iteratively determine the I_{sp} of the OMS. The I_{sp} was determined to be 305.6 sec. The fuel necessary for the mission was then determined using the rocket equation that relates mass and I_{sp} to ΔV . With a ΔV of 340 m/s, the total

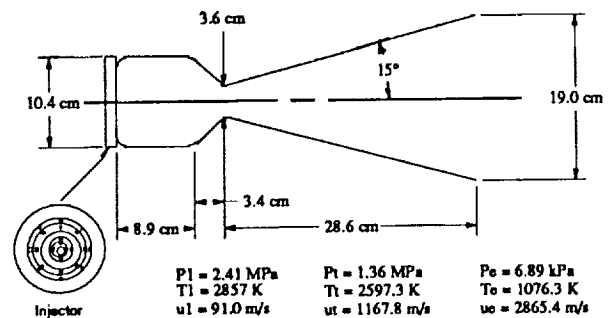

Fig. 7. Main engine dimensions.

propellant mass was determined to be 493.3 kg. The mass of the fuel and oxidizer was found using the mass ratio of oxidizer to fuel required for shifting equilibrium of hydrazine and nitrogen tetroxide, which is 1.08. The mass of hydrazine required for a ΔV of 340 m/s is 237.2 kg and the mass of the oxidizer is 256.1 kg.

As mentioned above, the propellant tanks and the main engines will be contained within the strap-on propulsion package, as shown in Fig. 8. The fuel and oxidizer tanks must remain a constant 3.10 MPa, and the highly pressurized gas to feed the system will be helium at 27.58 MPa. An isentropic process was assumed in order to calculate the 12.7 kg of helium necessary for the pressurant. There will be two sets of tanks for all four engines. There will be two sets of tanks for all four engines. A total of six tanks (two fuel, two oxidizer, and two helium) will be connected across from one another in parallel so that if one set failed, the second set, along with the RCS, could safely stabilize the craft.

For the DART vehicle, the module containing the propellant tanks has a relatively large length-to-diameter, so cylindrical tanks will be used for the fuel and oxidizer. Due to the very high pressure required, spherical tanks are used for the helium. The most important factor in the selection of construction materials for propellant tanks is strength-to-density ratio. Comparing this ratio for tanks made of aluminum, stainless steel, and fiberglass, it was found that the best ratio can be achieved with a fiberglass-wound tank containing an aluminum-alloy liner. The liner will be corrugated to extend pressure cycle life.

The DART RCS has two major functions: to counteract adverse motion due to forces and moments, and to maneuver the vehicle for attitude control purposes and reentry. Besides perturbations due to nodal regression and apsidal shifting, other principal forces that the spacecraft will experience during its mission include aerodynamic drag and internal acceleration. Internal acceleration can be attributed to propellant shifting, astronaut movement, and the deployment of solar array panels.

The RCS thruster system will be pressure fed, with the thruster locations shown in Fig. 9 and the specifications given in Table 5. The required thrust was calculated from the maximum rotational angular velocity of the DART capsule. The thrust must adequately counteract the angular moments about all major axes. Again, a combination of hydrazine and nitrogen tetroxide was chosen with helium as the high pressure gas. Spherical tanks are used due to their small surface-to-volume ratio. The fuel and oxidizer

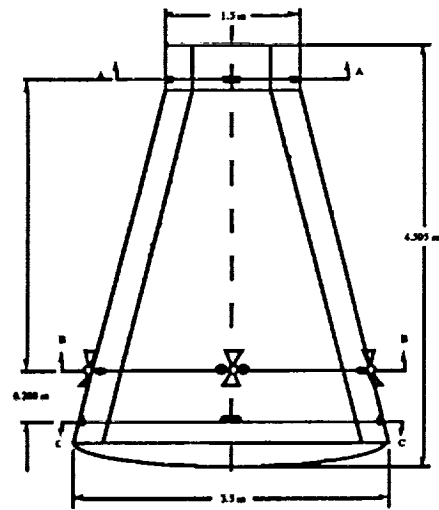

Fig. 9. RCS thruster locations.

tanks will have a pressure of 1.034 MPa, while the helium will be stored at a pressure of 10.0 MPa. Since nitrogen tetroxide is very corrosive and explosive, the tank material chosen is Ti-6 Al-4V ELI. The helium and fuel tanks will be made of composites lined with aluminum.

TABLE 5. Thruster specifications.

Section	Thrust (N)	Mass (kg)
A-A Vernier	100.0	1.090
B-B	351.0	2.260
B-B Vernier	42.0	0.634

The DART spacecraft's power generation requirement is set at 1500 W of continuous electrical power. A solar array was chosen as DART's primary power supply. Depending upon the solar angle of incidence, the time of direct sunlight will be approximately 60.4%. The mass of the assembled solar cells will be 12.44 kg, and the mass of the flexible roll-up blanket that will be used to deploy the solar array is 25.05 kg. The solar cell and blanket assembly will be rolled up into a 0.25-m-diameter cylinder that will be stowed inside the spacecraft until it is safely delivered to orbit. At this point, small motor will unroll the blanket and will keep it taut throughout the mission.

The solar array will be backed up by a secondary system consisting of silver-zinc rechargeable batteries. The battery system will be turned on automatically when the power demand increases or during solar eclipses. The baseline LEO that DART will maintain has a period of 94 min. This means that the spacecraft will be in shadow 39.6% of the time, or 47.52 hours. The batteries will supply the same amount of power as the solar array so that the total energy required during the 47.52 hours is 71.28 kw-hr.

Since silver-zinc batteries have a lifecycle of 20 to 200 cycles, they can constantly be recharged using solar cell electrical output. At a discharge rate of 10 hours the batteries will be

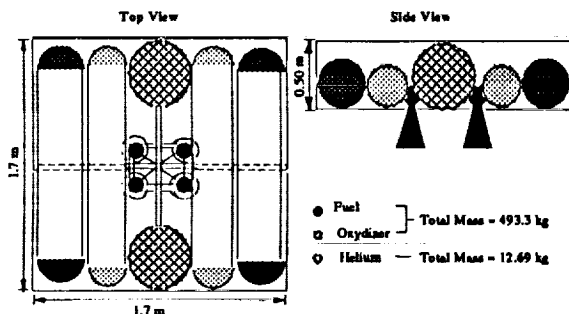

Fig. 8. Propulsion package configuration.

recharged five times during the mission, reducing the total weight of the batteries to 93.76 kg. Four batteries will be used to add redundancy; three batteries will be charged and discharged to supply the power needed and the other battery will be reserved for possible emergencies, with enough power for three hours.

AVIONICS

The DART spacecraft uses the LTN-90 ring laser gyro inertial navigation system (INS) as both the primary attitude source and as the sensor for position, velocity, rotation rate, and acceleration. The LTN-90 is composed of an inertial sensor display unit, a mode selector, and an inertial reference unit. In the inertial reference unit are the ring laser gyros (RLG), which measure rotation accelerations and rates about the three spacecraft axes, and three single axis accelerometers, which measure accelerations and rates.

Because the positional error of the LTN-90 increases every hour, it will have to be updated by another navigation system. The primary satellite navigational system considered for updates is the Global Positioning System (GPS). GPS is a satellite-based navigational system that will give continuous worldwide coverage by 1992, when 21 operational satellites are scheduled to be in orbit. The satellites orbit once every 12 hours ensuring that at least 4 satellites will be in view at all times.

Attitude determination and control of the DART spacecraft requires an accuracy of better than 0.25° . Five different systems were studied for the DART attitude control system. These five systems include reaction wheels, momentum wheels, reaction thrusters, control moment gyros, and magnetic torquers. As previously discussed in the "Propulsion and Power Systems" section, reaction thrusters were chosen for the DART spacecraft's attitude control system because of their accuracy and quick response capability.

The primary function of the data processing system is to monitor all equipment on the capsule. Through the use of sensors and output devices, this system will keep the astronauts informed about the status of all DART systems. The processing of this information involves reading in the sensor data and comparing the value with limits set for that sensor. If the value is not within the specified range, a warning light is activated and action is then taken to correct the problem.

Another function of the data processing system is to make the necessary computations for the OMS and the RCS. These computations involve determining the directional vector to the target position, number and duration of the OMS engine burns, and the required thruster firings for the attitude control. The data processing system is also required to interact with other external systems on the spacecraft. For example, the communication system must be linked to the processors to allow for data uplink and downlink.

Three major types of architectures were studied for the data processing system: centralized, federated, and distributed. A centralized system was chosen for DART. The configuration entails four general-purpose processors for guidance, navigation, and control. From these central processors will be links to main memory, the sensors, display controls, engine interfaces, and other external surfaces. These four processors will perform

synchronized computations, and intercomputer comparisons will be done to check for computational errors. In the event of a disagreement, the outvoted processor removes itself from the loop and attempts self-correction.

Each processor will have its own 16 Mbytes of RAM. This size allows for an estimated 1 Mbyte of software, 8 Mbytes reserved for runtime memory, and 7 Mbytes for temporary data storage and uplinked code, if needed. The design of the data bus consists of a two-way linear bus configuration. Fifteen busses will be used on DART: four between the four processors, two for sensors, two for mass memory, two for displays and keyboards, two for engine interfaces, and two for external interfaces and communications.

The choice of display equipment involved three types: CRTs, liquid crystal displays (LCD), and luminous flat panels. LCDs will be used for the DART's three displays. One of these displays will be used for the video camera needed for rendezvous and inspection; the other two are for the pilots.

Sensors return information concerning all operational systems on DART to the astronauts. These sensors will be applied to the following DART vehicle systems: propulsion, life support, reaction control, and abort. For the propulsion system, 172 sensors will be necessary to monitor the fuel, oxidizer, and pressurant tanks. Conditions that will be monitored include temperature, pressure, flow rate, and valve openings. For the life support system (LSS) 179 sensors will be necessary to measure the conditions of the nitrogen and oxygen tanks as well as the cabin atmosphere. Ninety-eight sensors are required to measure RCS tank and thruster temperatures. In addition, sensors are also needed for hatch closure, docking, and abort system confirmation. In all, 469 sensors with a total mass of 30 kg will be used on the DART spacecraft. An additional 120 kg has been allocated for wiring and digital/analog converters.

Since the DART spacecraft will be performing rendezvous and docking maneuvers, a radar system is required. A trade-off study was performed that compared the Lunar Sounder, SEASAT Synthetic Aperture, OMV, and the Integrated Radar and Communications Subsystem (IRACS) radar systems. The IRACS system was chosen because it not only functions as a rendezvous radar, but can also operate as a communications system capable of a two-way link between orbiter and ground tracking stations. The system is compatible with TDRSS and can be used as a backup in case of navigation malfunctions.

DART's communication needs include video, audio, data, EVA, radar, and navigational transmissions. The primary receiving station will be TDRSS, which currently consists of two satellites that will enable communications for 80 minutes of the DART spacecraft's 94-minute orbit. If communications cannot be made through TDRSS, the second choice will be direct transmission to Earth. The number of Earth stations is limited, but there could be three or more used per orbit, which would account for about 30 minutes of transmission per 94-minute orbit.

As stated above, the DART capsule will receive transmissions from the GPS for navigational updates. An antenna and receiver are required and the system operates on two frequencies, one at 1.575 GHz and the other at 1.228 GHz. The bandwidth for these base frequencies was determined from the amount of data that must be transmitted each second and the clarity that the data must have in order to be receivable. The link budgets

are used to determine whether or not a signal will be receivable. The overall qualifying figure in the link budget determination is the carrier-to-noise ratio. This ratio must be positive and be at least 10.0 to 12.5 dB in order for the signal to have good reception⁽³⁾. The weakest link is the downlink to TDRSS. In this link, the carrier-to-noise ratio has been reduced to the minimum needed for good reception.

Different antennas are needed in order to transmit and receive the desired frequencies. For the S-band a dipole antenna will be housed under a skin blemish to avoid the need for mechanical deployment. There will be two such antennas, one facing the Earth and one 180° around the spacecraft so that it is facing space. The UHF band will use a helical coil antenna because of its suitability to EVA communications applications. It will be located on the egress face of the capsule, so as to face the astronauts as they perform EVA. The Ku-band is appropriate for the high data rate requirements of the video link, which infers a very wide bandwidth. To fulfill these requirements, a deployable parabolic antenna of 0.5 m diameter will deploy out of a slot on the pilot's left side through the exterior skin of the capsule. Its location was chosen to allow the antenna to point toward both TDRSS and Earth during orbit. The L-band antenna will be mounted in the same fashion as the S-band antennas, but only on the surface facing GPS satellites.

HUMAN FACTORS

The internal layout of the DART capsule can be seen in Fig. 2. At the top of the capsule is the front hatch, which has a video camera on the outside to aid in rendezvous and docking. Moving into the capsule through the docking tunnel, control panels are encountered. Behind these control panels are the avionics systems, with extra space for avionics and control packages in the 0.3-m-thick capsule wall. Included in this total wall thickness is the heat shielding, external honeycomb shell, load frames, internal pressure vessel wall, and RCS thruster tanks.

At the end of this passageway are the pilot and copilot seats. Three-point harnesses will be used for all the crew to ensure maximum mobility while effectively securing the astronauts to their seats. However, since the pilots will be on their backs during launch and reentry, foot restraints are necessary to keep their legs from coming up into their chests. These restraints are located underneath the console directly in front of them. A small window is located on either side of the capsule, allowing the pilots limited outer visibility. A window was found to be needed, even if small, to give the astronauts a better sense of attitude and direction.

Moving through the 0.5-m passageway between pilot seats towards the back of the capsule, there are three couches for passengers and a side hatch for crew ingress/egress (see Fig. 10). Specifications of the seating facilities dictate that the maximum height and mass of the astronauts be 1.8 m and 80 kg, respectively. This crew seating configuration achieves an effective center of mass as well as 2.44 m³ of storage compartment volume around the couches. Another added feature of the couch design is the ability of the couches to be easily removed. According to mission needs, as many as three couches can be removed either on the ground or at the space station to allow more room for

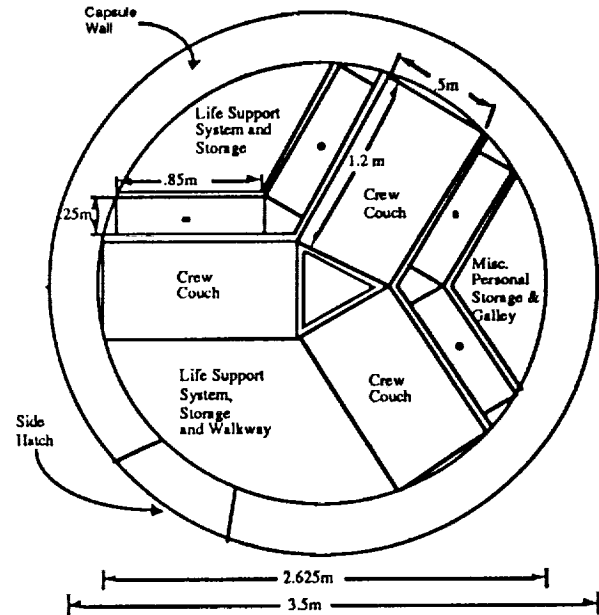

Fig. 10. Crew seating diagram.

storage and/or experiments. The volume attainable with three couches removed is 3.16 m³. Below this level are the water and LSS tanks, solar arrays, and batteries.

The radiation environment that the DART spacecraft will be exposed to during its proposed missions will not be a problem for the astronauts. In LEO at an inclination of 28.5°, the predominant source of radiation are the protons from Earth's Van Allen belts. It was calculated that the daily exposure to the crew would be about 185 mrem. At this daily dosage level, it would take 270 days to reach the NASA recommended annual exposure limit of 50 rem. Thus, the shielding provided by DART's honeycomb external shell and inner pressure vessel is adequate to protect the astronauts from dangerous radiation levels. As a precaution, passive radiation dosimeters (PRD) will be employed to measure the exact amount of radiation encountered by the astronauts.

The interior of the DART capsule will be held at standard atmospheric conditions. The metabolic oxygen requirement is an average of 1.0 kg per person-day; the amount of waste metabolic carbon dioxide produced will also be 1.0 kg per person-day. The carbon dioxide will be removed from the atmosphere using solid amine, which consists of small microporous beads whose surface is covered by amine. The beads themselves are composed of a polymeric acrylic ester. Since solid amine absorbs carbon dioxide at room temperature, it is easy to use and economical. The cabin air will be passed through an inlet filter to remove any trace elements or particles, then into a chamber where one of three amine canisters will be located. When the amine canister becomes saturated with carbon dioxide, the inlet flow will be switched to another canister. The saturated canister is then heated and the desorbed carbon dioxide is sent through a compressor and stored. The system will operate at a rate of 3600 lt/hr, have a total mass of just over 50 kg, a volume

of under 0.4 m^3 and requires 300 W of power for the compressor, pumps, and heaters.

The necessary elements for fire are fuel, oxygen, and a means of ignition. Ionization smoke detectors will be placed where trouble spots are expected (i.e., oxygen tanks, electronics, etc.). Fire extinguishment will be accomplished using Halon 1301, a chemical that inhibits the combustion reaction. Unreacted halon 1301 is harmless to humans for short exposures; however, when used on a fire, both hydrogen fluoride and hydrogen bromide (which are toxic in an enclosed atmosphere) result. This requires that the DART capsule be returned to Earth immediately in the event of a fire.

When the DART astronauts suit-up at KSC, they will be donning virtually the same suits worn by the crew of the space shuttle. The only difference is that they will not have a self-sustaining LSS permanently attached to their backs. The suit will be totally dependent on the capsule's LSS during launch, reentry, and depressurization. During the mission, a shirt-sleeve environment will be available. This enables the astronauts to wear cotton pants, shirts and jackets if desired.

Sufficient food and water must be available to supply the required 2500-3200 daily calories for a male crew member and 2200-2900 daily calories for a female crew member. The two types of food rations chosen for the DART spacecraft are the standard shuttle ration and the Meal Ready to Eat (MRE) ration. The shuttle ration offers over 23 menus, all of which are thermostabilized and dehydrated. If any heating of the food is required, a chemical heat packet is included in the packaging.

Each shuttle ration packs 2750 calories in it, and has a dry weight of 1.5 kg. To this, 1.9 kg of preparatory water must be added. Each meal takes up a volume of 0.004 m^3 , increasing to 0.005 m^3 when the preparatory water is added. The shuttle ration will be used for all planned meals, with the MRE ration relegated for the one-day emergency reserve. The MRE ration was originally developed for U.S. special forces field use. As such, it is very compact, needing no preparation to eat. The MRE packs 2600 calories per meal, has 12 different menus currently available, weighs 3.1 kg, and fits into a volume of 0.004 m^3 .

The potable water requirements for each crew member are approximately 1.2 kg per person-day. This will have to be carried in full, because the mass and volume requirements of a water recycling system will be too great for the short duration of the planned mission.

Waste solids and liquids require special handling in a micro-gravity environment. Each crew member will, on average, produce 4.0 kg of waste per person-day. This waste includes exhaled carbon dioxide, perspiration, food packaging, urine, and fecal solids. A diaper-like undergarment made of rubberized nylon will be worn to collect urine. The urine will then be transferred by hose to a holding tank and eventually ejected into space. Feces are stored in "blue bags" similar to early U.S. space missions.

Hygiene washing will not be needed for mission durations of less than four days. For the longer missions, washing can be accomplished using a sponge in a water-tight cocoon. The cocoon can be folded up when not in use, with the excess water evacuated by pump. A shower using the cocoon will use approximately 2.0 kg of water. The life support mass breakdown, exclusive of consumable food and water, is given in Table 5.

TABLE 5. Life support mass breakdown.

Parameter	kg per Person-Day
Metabolic Oxygen	1.0
Metabolic CO_2	1.0
Potable Water	1.2
Perspiration/Respiration Water	1.8
Trash Solids	0.05
Trash Liquids	0.12
Fecal Water	2.0
Fecal Solids	0.09
Hygiene Water	4.0

REENTRY STUDIES

The DART spacecraft's reentry is modeled as semiballistic with a L/D ratio of 0.25. The reentry scenario begins with an impulse thrust maneuver at an altitude of 500 km. The ΔV from this thrust will produce a change in altitude by altering the orbit of the vehicle to that of an ellipse with apogee at 500 km. The intermediate phase of the reentry will begin at about 120 km where the deceleration of the DART capsule will become significant due to Earth's atmosphere. The trajectory to this altitude is calculated by using the vis-viva equation for Keplerian ellipse geometry.

The reentry equations of the intermediate and gas dynamic phases can be derived by summing the forces in two dimensions and making the lift vector normal to the capsule. These equations can then be utilized in a second-order differential equation. The Z-function method by Chapman⁽⁴⁾ is applied to solve this differential equation using a computer program that was written for this DART reentry analysis. Fig. 11, a plot of altitude vs. velocity for different initial flight path angles, is a result of this analysis. Besides velocity, variations in deceleration, flight angle, and density were also calculated vs. altitude.

The reentry aerodynamic and thermodynamic properties of the DART spacecraft are dependent upon the flight trajectory, the orientation of the spacecraft, and the shape of the outer shell. The reentry trajectory calculated above is utilized in the analyses described below. A radius of curvature of 5.6 m was determined for the aft heat shield portion of the DART capsule.

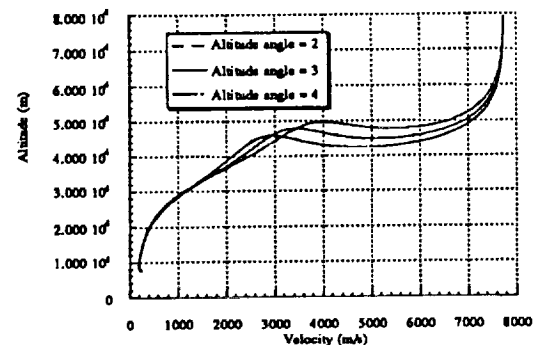

Fig. 11. Velocity vs. altitude for various initial flight path angles.

Given this symmetrical, spherical aft heat shield, a L/D ratio of 0.25 can be achieved by changing the trim angle of attack. This is accomplished by designing the DART center of gravity to be in a location where no resulting moment can occur. From Fig. 12, it is seen that given a radius of curvature of 5.6 m and a L/D ratio of 0.25, the corresponding angle of attack is approximately 15°. The required center of gravity offset from the capsule centerline (0.064 m) was then found from force coefficient results.

In addition, the pressure distribution across the aft heat shield was also calculated assuming modified Newtonian flow. At the maximum heating conditions, the pressure ratio was found to be 500 and the maximum pressure 5E7 N/m².

To protect the DART spacecraft from the high aerodynamic heating loads seen during reentry, a TPS will be applied to the outer structural skin of the vehicle (see Fig. 13). A detailed aerodynamic heating analysis was conducted to calculate the heat distribution on the vehicle during reentry. For this analysis, the TPS was divided into two parts: (1) the aft heat shield and (2) the conical heat shield. It was determined from the DART reentry trajectory study that the peak heating rate occurs at an altitude of 53,555 m. Standard atmospheric conditions at this altitude were used in the convective heat flux equations⁽⁵⁾. Therefore, the heating results shown in Fig. 14 represent the highest temperatures and convective heat fluxes that will be seen by the DART capsule during reentry.

Using these results, a trade-off study was conducted to determine the most appropriate material(s) for the DART TPS. Materials under consideration included ablative, ceramic tiles, carbon carbon, cork, and thermal blankets. The results of the heating analysis support the use of a combination of ablative material and thermal blankets as seen in Fig. 13. The ablative material will cover the aft heat shield and the lower portion of the conical heat shield. Low-density phenolic epoxy resin was chosen for its low mass, low material cost, and thermal characteristics. The phenolic epoxy resin can be applied to the DART vehicle in the form of spray-on foam and can be stripped during refurbishment with a water cannon. Thermal blankets consisting of low-density fibrous silica batting protect the upper conical section of the capsule during reentry. The reusable blankets dissipate heat by radiating it away from the capsule. The baseline method for ablator and thermal blanket attachment will be direct bond as opposed to subpanel methods.

The DART spacecraft will use a parachute recovery system. A paraglider landing system was also researched, but the parachute was chosen due to mass and volume constraints. Two parachutes were chosen because larger chutes are more difficult to manufacture and take longer to deploy. Note that each parachute will require a diameter of 41 m in order to give the capsule a descent rate of 7.62 m/s. Also, in the event of a single parachute failure, the other will safely recover the DART capsule with a descent rate of 10.79 m/s.

The parachute deployment sequence begins at an altitude of 4000 m with the extraction of the pilot parachutes by mortars. The pilot parachutes, in turn, deploy the main parachutes, which fully inflate in 6 s. After the parachutes have been deployed and stabilized, a simple mechanism will release the aft heat shield, which is connected to an air bag. The air bag functions to soften the water impact and will be filled with helium.

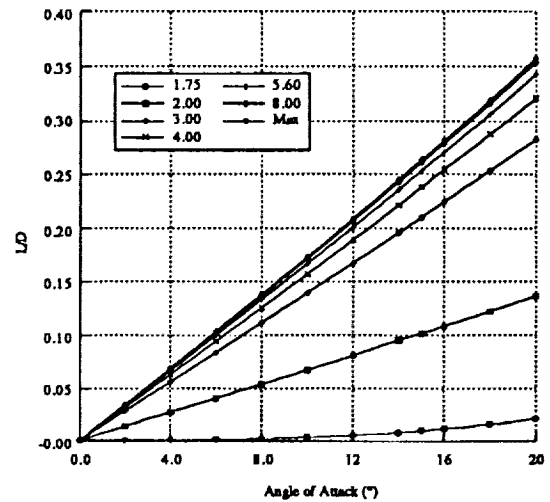

Fig. 12. L/D vs. angle of attack for different radii of curvature.

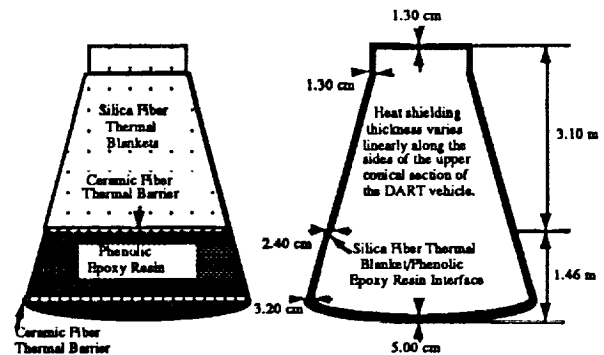

Fig. 13. TPS configuration and thickness.

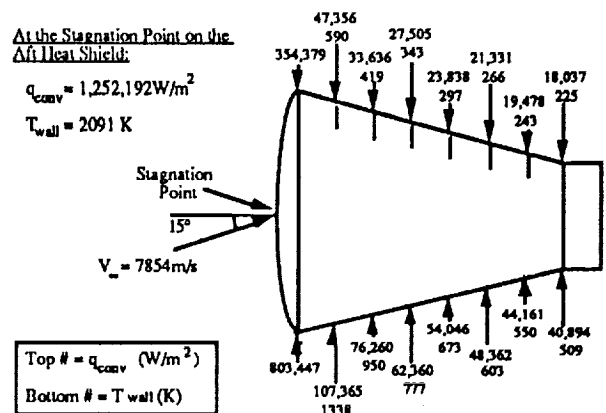

Fig. 14. Aerodynamic heating analysis results.

Constructed of nylon cloth covered with a thin coating of rubber, cables will be added to the outside surface of the bag for reinforcement. Note that the aft heat shield remains attached to the bottom of the bag and serves to stabilize the capsule in rough waters by lowering its center of gravity.

REFURBISHMENT AND COSTING

The refurbishment fraction, f , is a percentage of the initial cost used to project the reuse and refurbishment cost for a system over its mission model. Historically, the fraction ranges from 0.03 for the X-15 to 0.10 for the space shuttle. The minimum mission model for the DART AMS is 10 flights per year for 20 years.

The refurbishment fraction is really the sum of two parts: the refitting of the capsule per year of the model with new systems (based on the original unit costs), and the refurbishment of the system per year over the model. A mathematical model that estimates the lifespan of DART components and uses a power law to increase the percentage of systems needing refitting per year is applied. Using this model, the refitting portion of the refurbishment fraction was found to be 0.05 while the refurbishment part was calculated at 0.02, resulting in a refurbishment fraction of 0.07.

An accurate and detailed costing analysis for the DART spacecraft is necessary for many reasons. One reason is to show that the spacecraft is an affordable addition to the U.S. Space Program. Another reason is to demonstrate the economical advantages of DART's partially reusable design.

The main costs were broken down into two categories: recurring and nonrecurring. Recurring costs include the cost of the craft itself, transportation, launch vehicle costs, launch preparations, ground support, recovery, and refurbishment. Nonrecurring costs include the cost of preparing to produce the spacecraft and the cost of adapting the existing infrastructure to accommodate the operation of the craft. The total program cost is found by adding together the recurring and nonrecurring costs, and then adding the cost of ground support equipment, subsystem development tests, and project management. For a flight model of 150 flights (10 per year for 15 years) and a refurbishment factor of 0.07, the cost model projects the total DART project cost will be 20.4 billion dollars or an average of 102 million dollars per flight (FY91 dollars).

A trade-off study compared the total program cost of a semireusable craft to that of an expendable one over constant mission model. This model set the number of missions per year at 10 a year for 20 years starting in 1995. Inflation was purposefully not accounted for so that the total program cost could be seen as an initial investment in 1991 dollars with interest yield the same as the inflation rate. The results of this study demonstrate that if more than 90 flights are expected, a semireusable spacecraft becomes more economical than an expendable one.

CONCLUSION

This summary outlined the advantages of DART as an alternative manned spacecraft. With the use of the Delta II 7920 commercial booster, DART will have a 96% reliable launch system if existing ground support facilities at Cape Canaveral, Florida, are utilized. The DART design team has refit a capsule-based manned space vehicle with current technology. The capsule has a launch weight of 4772 kg, a base diameter of 3.5 m, a height of 4.5 m, and a cone side angle of 15°. In orbit, propulsion is generated using a hypergolic, expendable propulsion package. The craft uses the Tracking Data Relay Satellite System in addition to the Global Positioning System for communications and positioning. DART's reentry will be semiballistic, with a parachute recovery to an Atlantic Ocean splashdown.

When integrated into the U.S. Manned Space Program, DART will provide flexible, reliable, and cost-effective access of crew and cargo to specific space destinations. This added capability will further microgravity experimentation and aid in the achievement of a permanent manned access to space. The DART program is designed for a mission model of 10 flights per year over 20 years, has a refurbishment fraction of 0.07, and a cost of \$102 million dollars per flight.

ACKNOWLEDGMENTS

This work was conducted with the support of the Advanced Space Design Program of the Universities Space Research Association. This support is gratefully acknowledged. Principal author T. Lewerenz and co-authors M. Kosha and H. Magazu summarized the work of O. Bello, R. Bennett, F. Carreon, R. Cunningham, T. Foor, M. Gates, A. Harrison, M. Kaczmarek, Z. Kahn, M. Kosha, K. Le, T. Lewerenz, D. Loveless, H. Magazu, D. Matthews, J. Travisano, E. Villacis, D. Vine, A. White, and C. White. Faculty advisors were D. Akin, M. Lewis, and C. Lind.

REFERENCES

1. Kaplan, Marshall, *Spacecraft Dynamics and Control*. New York: John Wiley & Sons, 1976.
2. Megyesy, Eugene F., *Pressure Vessel Handbook*. 1973.
3. Morgan, Walter I., and Gordon, Gary D., *Communications Satellite Handbook*. New York: John Wiley & Sons, 1989.
4. Chapman, D., "An Approximate Analytical Method for Studying Entry into Planetary Atmospheres." *NASA TR-11*, 1959.
5. Anderson, J. D., Jr., *Hypersonics and High Temperature Gas Dynamics*. New York: McGraw-Hill, Inc., 1989.

