

Library - L. M. A. L.

TECHNICAL NOTES

542

NATIONAL ADVISORY COMMITTEE FOR AERONAUTICS

No. 474

EFFECT OF STABILIZER LOCATION UPON PITCHING
AND YAWING MOMENTS IN SPINS AS SHOWN BY
TESTS WITH THE SPINNING BALANCE

By M. J. Bamber and C. H. Zimmerman
Langley Memorial Aeronautical Laboratory

Washington
November 1933

NATIONAL ADVISORY COMMITTEE FOR AERONAUTICS

TECHNICAL NOTE NO. 474

EFFECT OF STABILIZER LOCATION UPON PITCHING
AND YAWING MOMENTS IN SPINS AS SHOWN BY
TESTS WITH THE SPINNING BALANCE

By M. J. Bamber and C. H. Zimmerman

SUMMARY

Tests were made with the spinning balance in the N.A.C.A. 5-foot vertical tunnel to study the effect of stabilizer location upon the pitching and yawing moments given by the tail surfaces in spinning attitudes. The model was a low-wing monoplane with the fin faired into the fuselage. The program included tests with the horizontal surfaces in a conventional location, approximately one stabilizer-chord length ahead of that location, approximately one stabilizer-chord length aft of that location, near the top of the fin and rudder, and near the bottom of the fuselage.

The tests revealed that the horizontal surfaces when in a normal location seriously reduced the effectiveness of the fin and rudder, particularly at angles of attack of 50° or more; that a more forward or more rearward location gave no consistent or decided improvement; that a lower location greatly increased the shielding so that the yawing moment from the combination was in general less than that given by the bare fuselage; and that a higher location decreased the shielding and even gave a favorable interference effect, particularly at the high angles of attack.

The stabilizer and elevator gave the largest values of diving moment, in general, when in the low and in the most rearward locations. The elevator was most effective in the forward and the rearward locations. The high location resulted in small diving moments, and when so located the elevator was quite ineffective at angles of attack higher than 50° .

The measured values of pitching-moment coefficients obtained with the stabilizer and elevator in the low positions were in poor agreement with the computed values. The measured values were nearly twice as large as the computed values when there was no sideslip at the center of gravity.

Measured values of yawing-moment coefficient obtained with the fin and rudder unshielded showed fair agreement with computed values.

INTRODUCTION

It is quite evident to anyone familiar with the motion of a spinning airplane that there must be interference effects between the horizontal and vertical tail surfaces. The existence of such effects has been confirmed by tests upon free-flying models (reference 1), by smoke-flow tests (reference 2), and by tunnel tests with the spinning balance (reference 3). The magnitude of these interference effects, the relative efficiency of various combinations, and the effects of different spinning conditions upon the relative efficiencies have not been measured under conditions of motion simulating actual spinning conditions. In view of the fact that the conventional airplane can be brought out of a spin only by use of the controls at the tail, it seems very desirable that such measurements be made.

An investigation of this nature has been made possible by the development of the spinning balance, and the N.A.C.A. has prepared an extensive program of tests on various tail modifications in various spinning attitudes. At the request of the Materiel Division of the Army Air Corps, the first tests of this series, which are reported in this paper, were made upon a tail of design conventional in all respects except that the fin was thickened to fair into the fuselage. These tests covered the effect of stabilizer and elevator location upon the yawing and pitching moments given by the vertical and horizontal surfaces, respectively, in various spinning attitudes. Rolling moments and lateral, longitudinal, and normal forces were also measured, but they were little affected by the changes and will not be discussed in this paper. Additional tests will be carried out to study the effects of fuselage shape, plan form of the surfaces, thickness of the surfaces, wing interference, etc., as rapidly as circumstances permit.

APPARATUS AND MODELS

The tests were made on the spinning balance (reference 3) in the 5-foot open-throat vertical tunnel (reference 4).

The model was a low-wing monoplane which had been designed to facilitate testing of a large number of tail modifications (fig. 1). It consisted of a duralumin center sec-

tion fitted with a clamp for attachment to the spinning balance, a removable nose piece, a 5 by 30 inch mahogany wing of Clark Y section, and the particular tail assembly being tested.

The fin and rudder were conventional in plan form with a combined area of 5.8 percent of the wing area. The area of the fin was 38 percent of the combined area. The leading edge of the fin made an angle of 60° with the thrust line. The fin was thicker than the conventional type and was faired into the fuselage. (See fig. 2.)

The stabilizer and elevator were rectangular in plan form, with a combined aspect ratio of 3.27 and a total area 1.4 percent of the wing area. The stabilizer area was 60 percent of the combined area. The cut-out for the rudder was neglected in calculating these areas and the surfaces were assumed as being continuous through the fuselage. The airfoil section of the stabilizer and elevator was the N.A.C.A. 0009, a symmetrical section with a maximum thickness 2 percent of the chord. (See reference 5.) The various locations are shown in figure 1.

TESTS

Tests were made in the 9 spinning attitudes tabulated below:

α deg.	β deg.	ψ_1	Radius in.	Ω rad./sec.	w'' ft./sec.
40	6	$-23^\circ 29'$	4.36	27.1	65
40	0	$-16^\circ 52'$	4.36	27.1	65
40	-10	$-5^\circ 44'$	4.36	27.1	65
50	10	$-21^\circ 35'$	3.28	28.5	65
50	0	$-13^\circ 53'$	3.28	28.5	65
50	-10	$-5^\circ 41'$	3.28	28.5	65
70	10	$-12^\circ 15'$.97	26.5	45
70	0	$-8^\circ 6'$.97	26.5	45
70	-10	$-5^\circ 24'$.97	26.5	45

In the table, α and β represent the angles of attack and of sideslip, respectively, at the center of gravity; angle ψ is the angle between the projection of the X axis on a horizontal plane and the radius of spin, being positive when the model has been rotated clockwise (viewed from a point on the negative Z" axis) about a vertical axis from a position with the projection of the X axis coincident with the radius. It was not possible to get an angle of sideslip of 10° at an angle of attack of 40° without cutting away the center section an excessive amount.

The radius and the rate of rotation, Ω , for each angle of attack were computed from assumed values of weight, resultant aerodynamic force, aerodynamic pitching moment, and moments of inertia about the normal and the longitudinal axes. It was assumed that sideslip had but secondary effects upon these factors, and accordingly the same values of radius and rate of rotation were used for all angles of sideslip at any one angle of attack.

Tests were made with control surfaces neutral and set 35° with the spin (elevator up, rudder right in right spin or left in left spin) for each attitude with each of the 5 stabilizer and elevator locations, and with the stabilizer and elevator removed. Additional tests were made at each attitude with both horizontal and vertical surfaces removed.

The tunnel air speed, w , was reduced from 65 to 45 feet per second for the tests at 70° angle of attack, to avoid excessive rotational speeds. The Reynolds Number was approximately 169,000 at 65 feet per second and 117,000 at 45 feet per second on the basis of the 5-inch wing chord. Previous tests (reference 3) have indicated that scale effect is small in the range of Reynolds Numbers included.

A high degree of precision was difficult to achieve in these tests because the aerodynamic forces on the tail surfaces were only a small part of the total aerodynamic forces on the model. All points apparently questionable were checked. It is believed that the values given are within ± 0.02 for C_m and ± 0.005 for C_n , except for the values of ΔC_m , in which case the error may be as much as ± 0.04 . The larger errors probably occur at the lower values of angle of attack, in which condition the interference between the balance and the model affects the flow about the tail (reference 3).

RESULTS

The yawing moments given by the vertical surfaces were found by subtracting the values obtained with the horizontal and vertical surfaces removed from the values measured with the vertical and horizontal surfaces in place. The results are given in standard coefficient form (body axis),

$$C_n = \frac{N}{\frac{1}{2} \rho V^2 S b}$$

where V , velocity at the center of gravity

S , area of wing

b , span of wing

The pitching moments given by the horizontal surfaces were found by subtracting the values obtained with the horizontal surfaces removed and rudder neutral from the values measured with the vertical and horizontal surfaces in place. The results are given in coefficient form (body axis),

$$C_m = \frac{M}{\frac{1}{2} \rho V^2 S b}$$

Values of C_m can be converted to the standard form by multiplication by the ratio of span to chord ($\frac{b}{c} = 6$).

Values of C_n are plotted against angle of attack at the center of gravity for each stabilizer location as well as with the stabilizer removed, both with controls neutral and with controls with the spin (figs. 3 to 8, inclusive). The values are plotted as for a right spin. A positive value of C_n indicates a yawing moment aiding the rotation.

Calculated values of C_n are compared with values measured with the stabilizer removed (fig. 9). The calculated values were given by the relation

$$C_n = \frac{l}{b} \times 0.058 \times \left(\frac{V_t}{V}\right)^2 C_{L_t}$$

where l , distance from center of gravity to rudder hinge

$\bar{Q}.058$ = ratio of fin and rudder area to wing area

V_t , velocity at the tail

C_{Nt} , lift coefficient of an airfoil with an aspect ratio of 1.15 having the angle of attack of its zero-lift line equal to the angle of sideslip at the tail (reference 6).

Both V_t and the angle of sideslip at the tail were computed from the coordinates of the tail, the relative wind at the center of gravity, and the components of rotation about the respective axes.

Values of C_m are plotted against angle of attack at the center of gravity for each stabilizer location with the controls set with the spin (figs. 10, 11, and 12). Values of ΔC_m obtained by movement of the control surfaces from 35° with the spin to neutral are given in figures 13, 14, and 15.

Calculated values of C_m are compared with values measured with the stabilizer and elevator located at the bottom of the fuselage (fig. 16). The calculated values were given by the relation

$$C_m = \frac{l'}{b} \times 0.14 \times \left(\frac{V_t}{V}\right)^2 \times C_{Nt}$$

where l' , distance from center of gravity to quarter-chord point of stabilizer and elevator

0.14 = ratio of stabilizer and elevator area to wing area

and C_{Nt} , the normal-force coefficient of an airfoil with an aspect ratio of 3 having the angle of attack of its zero-lift line equal to the angle of attack at the tail (reference 6).

No allowance was made for downwash or wing-interference effects.

DISCUSSION

Importance of yawing moments in spins.— Equations of balance indicate that an airplane can achieve equilibrium

of forces when rotating at any angle of attack. Equilibrium of pitching moment can also be obtained if the rotational speed is not limited. Equilibrium of rolling moments (body axis) can be obtained at angles of attack above the stall if the angle of sideslip is not limited. In other words, there is the possibility of spinning equilibrium at any of a large number of values of angle of attack if balance of yawing moments (body axis) can be obtained, regardless of whether aerodynamic diving moments are large or small or whether the wing combination will or will not autorotate with zero sideslip. It is therefore very important that the designer know the yawing-moment characteristics of a proposed airplane when in spinning attitudes in order that he may guard against loss of life and property in uncontrollable spins.

Yawing moments about the body axis arise mainly from four sources: (1) the wings, (2) the fuselage, (3) difference in moments of inertia about the lateral and longitudinal axes (B and A, respectively) coupled with components of rotation about those axes, and (4) the vertical tail surfaces.

Of these moments, the wing moment is generally in a sense to aid the spin but is obviously limited in value because it can arise only out of differences in longitudinal force on the wing along its span. Strip-method calculations and wind-tunnel measurements (reference 7) indicate a possible maximum value of 0.02 for the wing yawing-moment coefficient aiding the spin.

The fuselage moment is small and generally in a sense to oppose the spin. The inertia moment is also generally small and in a sense to oppose the rotation (B larger than A, and sideslip at the center of gravity inward, zero, or less than the helix angle outward). These factors cannot be neglected and may become of primary importance in some designs, but need no further discussion here.

The moment given by the tail must be of the proper sign and magnitude to establish equilibrium if a steady spinning state is to be attained. It is obvious that such a condition can be prevented by so designing the tail that it will give a yawing moment opposing the spin large enough to prevent equilibrium.

The yawing moments given by the vertical surfaces depend upon the fin and rudder area and plan form, the dis-

tance from the c.g. to the tail, the rudder setting, the rotational speed, the angle of attack and the sideslip at the center of gravity, and the interference effects of the fuselage and the horizontal surfaces. For these tests the vertical surface area and plan form and the distance from the c.g. to the tail were chosen to be as nearly as possible representative of conventional practice. The effectiveness of each of the various tail combinations as sources of yawing moments in the various conditions of sideslip and angle of attack, both with controls with the spin and with controls neutral, is shown in figures 3 to 8, inclusive.

Effect of stabilizer location upon yawing-moment coefficient.— Inspection of the charts of yawing-moment coefficient with controls deflected (figs. 3, 4, and 5) reveals that the yawing moment opposing the spin increases with outward (negative) sideslip at the center of gravity; that, in general, it increases with increase in angle of attack; that none of the stabilizer locations is definitely superior to all the rest in all attitudes; and that there is a general tendency toward convergence of the curves at the angle of attack just above 40° . The low stabilizer location resulted in moments very conducive to spinning, particularly at the high angles of attack. There is little to choose between the others, although the normal location is least favorable to the spin at angles of attack of the order of 50° when the sideslip at the center of gravity is inward.

With controls neutral there is again evident a general increase of yawing moment opposing the spin with change from inward to outward sideslip and with increase in angle of attack. The low stabilizer location was least effective in most attitudes, particularly so at the higher angles of attack. The normal location was as effective as were the unshielded surfaces with inward sideslip, but it became less effective as the sideslip became negative. The forward stabilizer location gave about the same results as the normal location at all angles of attack with inward sideslip and at the higher angles of attack with zero sideslip. It gave a very small moment with zero sideslip at 40° angle of attack, but was better than the normal location at all angles of attack with outward sideslip. The aft location was definitely inferior to the normal stabilizer location when the sideslip was inward at all angles of attack, and when the sideslip was zero at 50° angle of attack. It was definitely superior to the normal location with outward sideslip at all angles of attack and of about the same effectiveness at 40° and 70° angles of attack with zero sideslip. The high location

was greatly superior to all the others, although it gave but a small moment at 40° angle of attack with inward sideslip.

Comparison of computed values of C_n with measured values.- In figure 9 is shown a comparison of values of C_n , computed as outlined under "Results" with values obtained from the tunnel measurements without the horizontal surfaces in place and with a zero rudder setting. The agreement is reasonably good. The measured yawing moments increased somewhat more rapidly with sideslip at the tail than did the computed values.

Importance of pitching moments in spins.- A study made by the authors over a period of several years indicates that the following general statements can be made with regard to the function of the pitching moment in steady spins. Large aerodynamic diving moments tend to prevent spinning equilibrium and to insure recovery, if the vertical surfaces are effectively disposed. This statement is not necessarily true if the characteristics of the wing cellule are such that the amount of sideslip required for rolling-moment equilibrium changes from a large value outward to a large value inward as the rate of rotation and the angle of attack increase. Such a condition may possibly be encountered with an unstaggered biplane but is very unlikely to occur in other cases.

If the vertical surfaces are ineffective, it is desirable that the diving moment be small with elevator up and that it be possible suddenly to increase greatly the diving moment in order to effect recovery. Large diving moments with the elevator up will result in fast, flat spins from which recovery is doubtful if the vertical surfaces are ineffective.

Effect of stabilizer location upon pitching-moment coefficient.- The effect of stabilizer location upon pitching moments is shown in figures 10 to 15, inclusive. The rearward and the low locations gave, in general, the largest diving moments. The forward location gave small diving moments. When in the high location the stabilizer and elevator gave small diving moments at the low angles of attack with zero and outward sideslip.

The forward and the rear locations gave the greatest elevator effectiveness under most conditions. The change in $C_{L\dot{\alpha}}$ when the controls were neutralized with the stabilizer in the high position, such as to decrease the diving moment at angles of attack of 50° and above. X

Comparison of computed values of C_m with measured values.— In figure 16 is shown a comparison of values of C_m computed as outlined under "Results" with values obtained from tunnel measurements with the horizontal surfaces near the bottom of the fuselage. The agreement between the calculated values and the measured values is not very good except with outward sideslip at 40° angle of attack and with inward sideslip above 50° angle of attack. The poor agreement is probably due to wing-interference and fuselage-interference effects upon the air flow at the tail. Insufficient experimental evidence is at hand to prove or disprove such a supposition.

CONCLUSIONS

1. Shifting the horizontal tail surfaces from the bottom of the fuselage to the top of the fin increases the yawing-moment coefficient (body axis) opposing the spin from a small value to a value greater than that given by the fuselage and the vertical surfaces with the horizontal surfaces removed.
2. The yawing-moment coefficient given in spinning attitudes by a fin and rudder with horizontal surfaces removed can be computed with reasonable accuracy for tails with the fin faired into the fuselage.
3. The location of the stabilizer and elevator has a marked effect upon the pitching moment produced by the tail.
4. There is apparently an unexplained factor entering into the flow about the tail which makes questionable the computations of the pitching moment produced by the tail.

Langley Memorial Aeronautical Laboratory,
National Advisory Committee for Aeronautics,
Langley Field, Va., September 30, 1933.

REFERENCES

1. Stephens, A. V.: Free-Flight Spinning Experiments with Several Models. R. & M. No. 1404, British A.R.C., 1931.
2. Scudder, N. F., and Miller, M. P.: The Nature of Air Flow about the Tail of an Airplane in a Spin. T.N. No. 421, N.A.C.A., 1932.
3. Bamber, M. J., and Zimmerman, C. H.: The Aerodynamic Forces and Moments Exerted on a Spinning Model of the "NY-1" Airplane as Measured by the Spinning Balance. T.R. No. 456, N.A.C.A., 1933.
4. Wenzinger, Carl J., and Harris, Thomas A.: The Vertical Wing Tunnel of the National Advisory Committee for Aeronautics. T.R. No. 387, N.A.C.A., 1931.
5. Jacobs, Eastman N.: Tests of Six Symmetrical Airfoils in the Variable Density Wind Tunnel. T.N. No. 385, N.A.C.A., 1931.
6. Zimmerman, C. H.: Characteristics of Clark Y Airfoils of Small Aspect Ratios. T.R. No. 431, N.A.C.A., 1932.
7. Irving, H. B., and Stephens, A. V.: Safety in Spinning. R.A.S. Journal, March 1932, pp. 145-204.

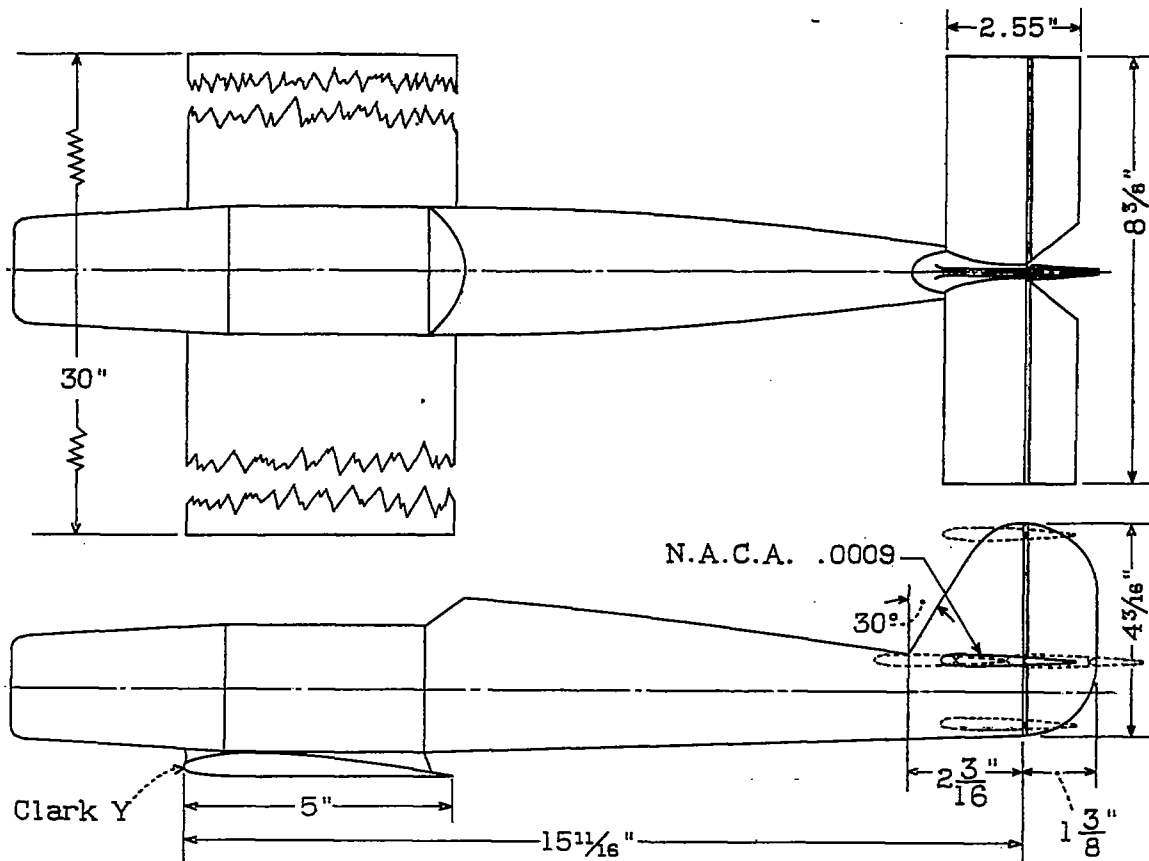

Figure 1.- Low-wing monoplane model used in testing tail combinations in spins.

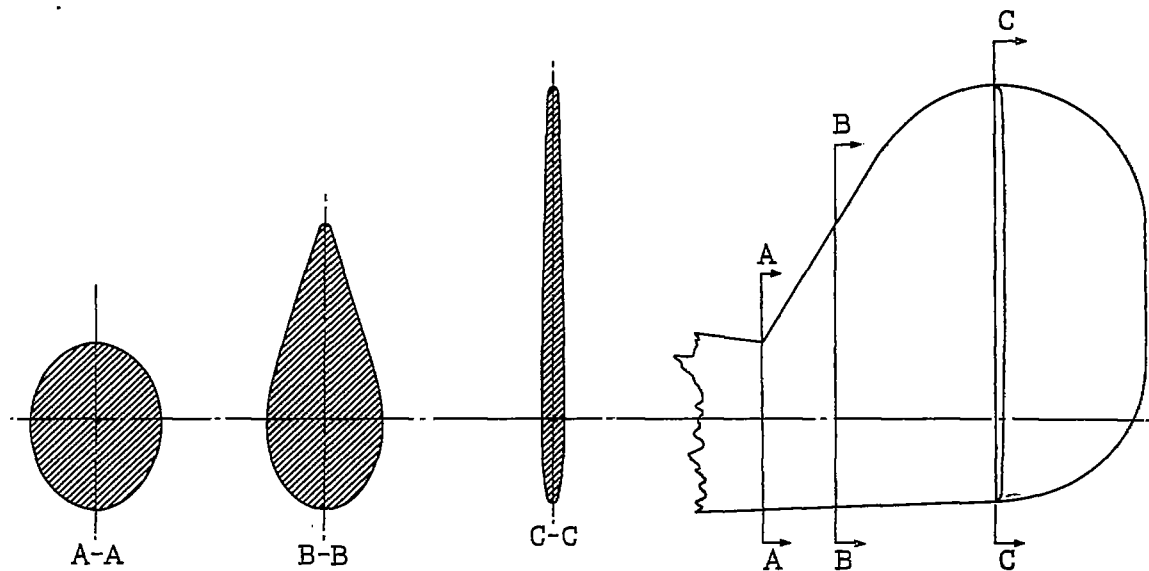

Figure 2.- Sections through fin and fuselage.

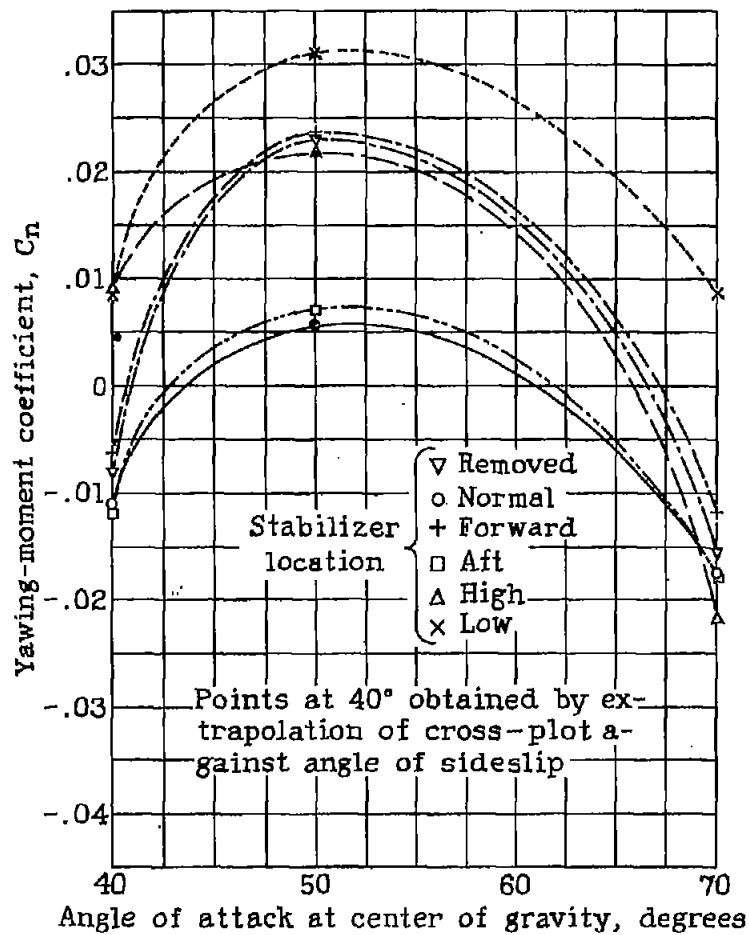

Figure 3.- Yawing-moment coefficients due to fin and rudder. Sideslip at c.g. 10° (inward). C_n (controls 35° with the spin), $-C_n$ (tail surfaces removed).

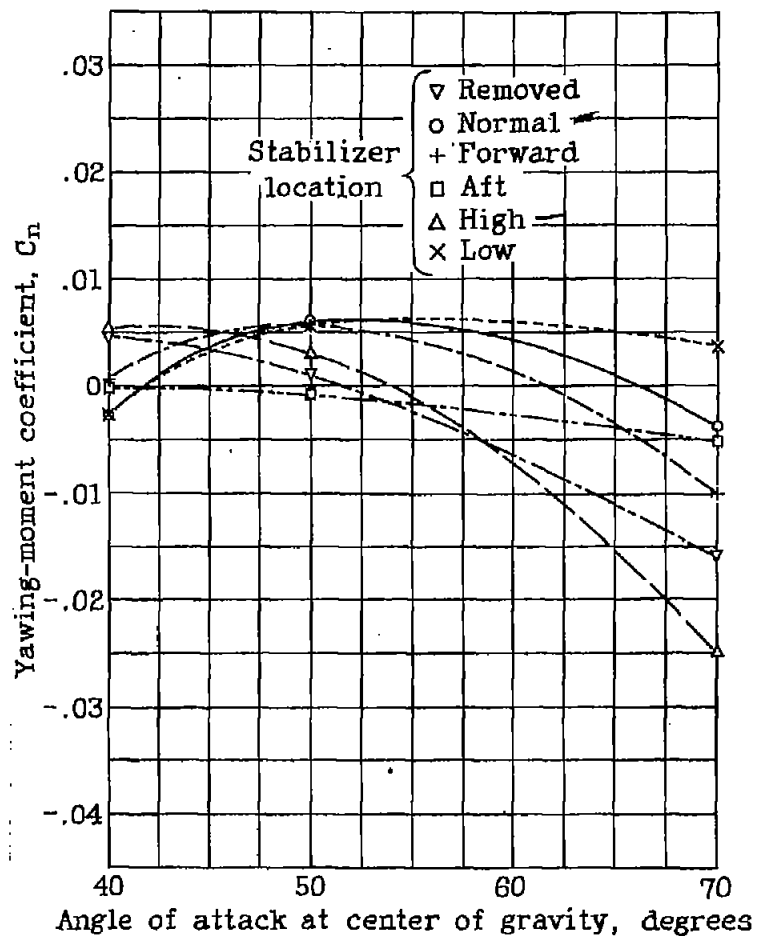

Figure 4.- Yawing-moment coefficients due to fin and rudder. Sideslip at c.g. 0°. C_n (controls 35° with the spin), $-C_n$ (tail surfaces removed).

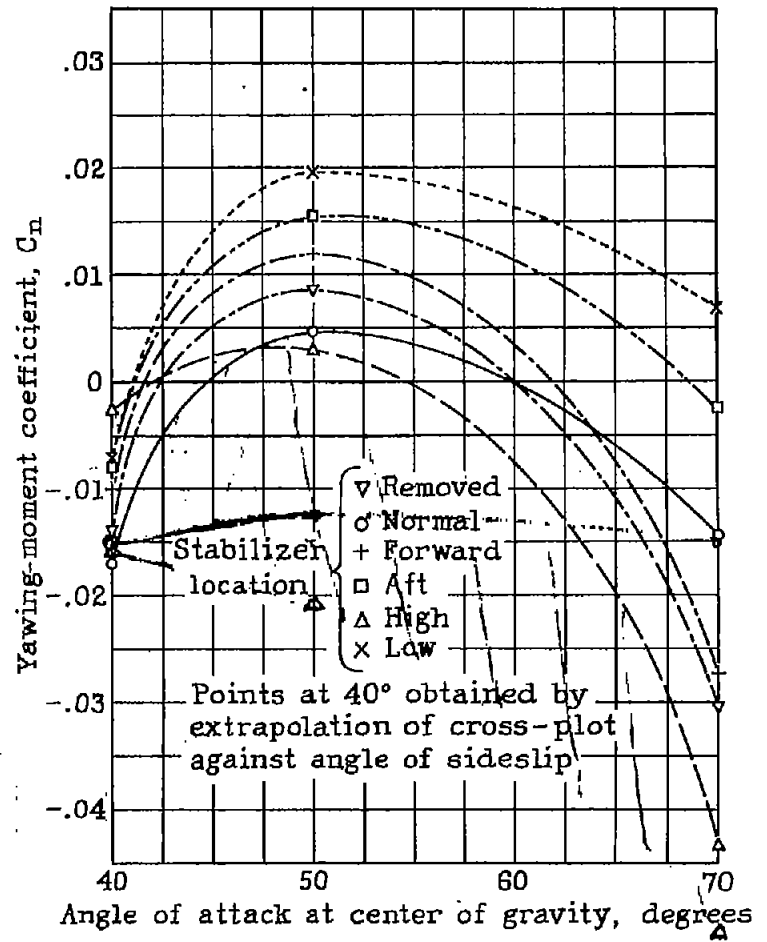
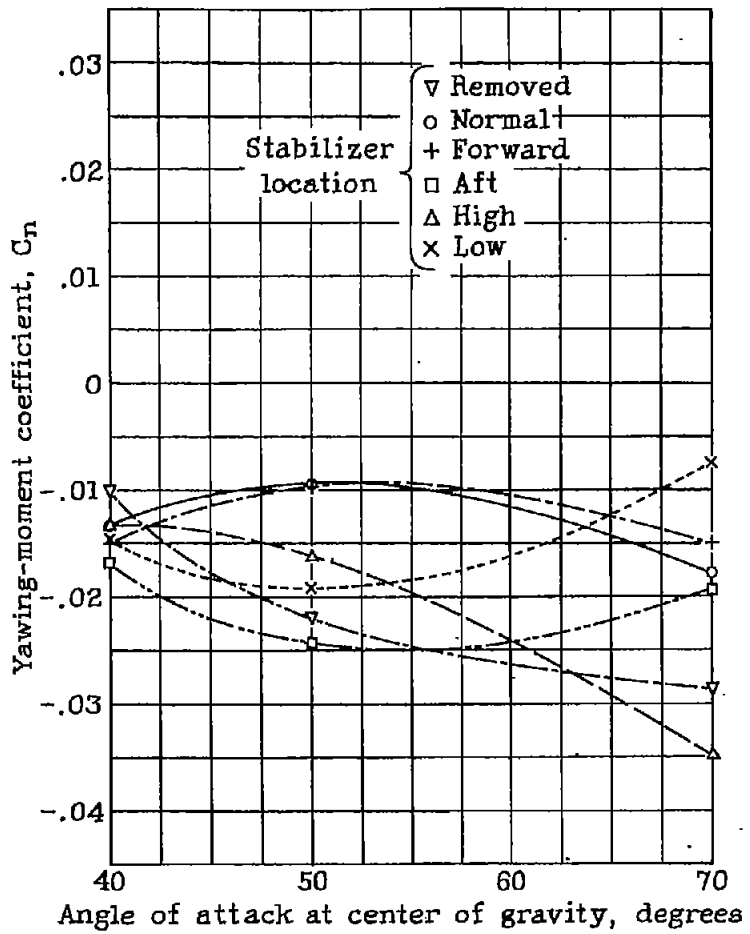

Figure 5.- Yawing-moment coefficients due to fin and rudder. Sideslip at c.g. -10° (outward). C_n (controls 35° with the spin), $-C_n$ (tail surfaces removed).

Figure 6.- Yawing-moment coefficients due to fin and rudder. Sideslip at c.g. 10° (inward). C_n (controls neutral), $-C_n$ (tail surfaces removed).

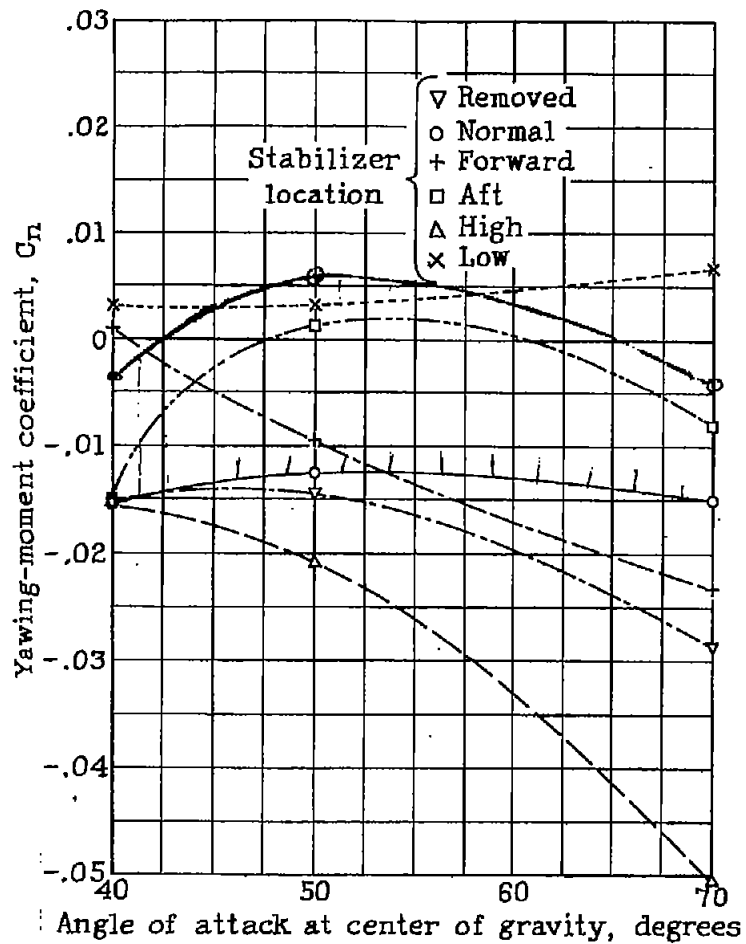

Figure 7.- Yawing-moment coefficients due to fin and rudder. Sideslip at c.g. 0° . C_n (controls neutral), $-C_n$ (tail surfaces removed).

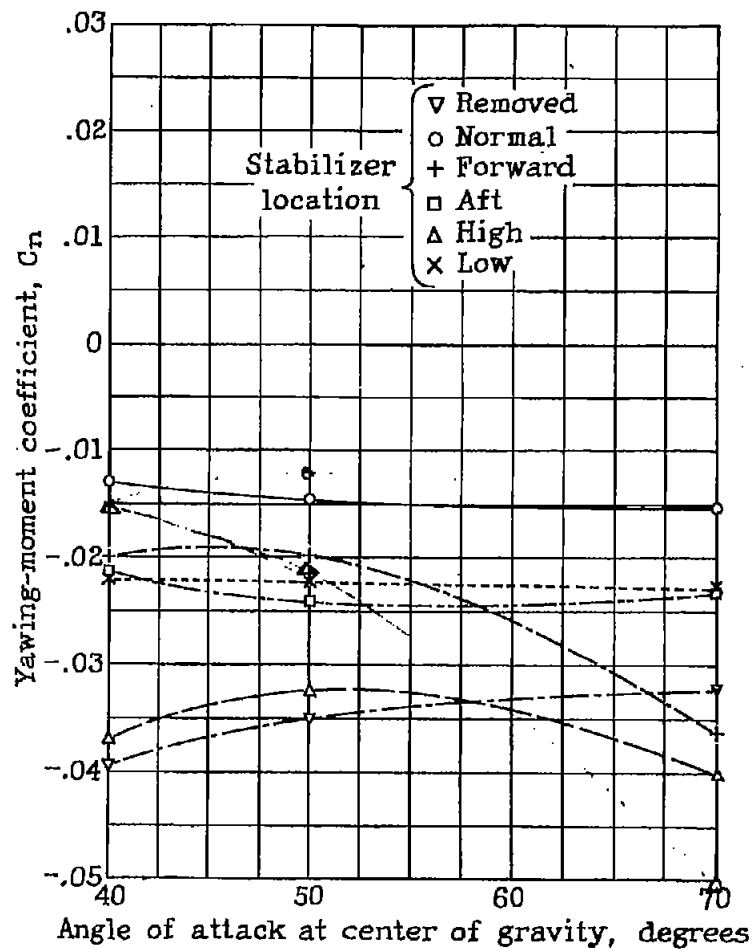

Figure 8.- Yawing-moment coefficients due to fin and rudder. Sideslip at c.g. -10° (outward). C_n (controls neutral), $-C_n$ (tail surfaces removed).

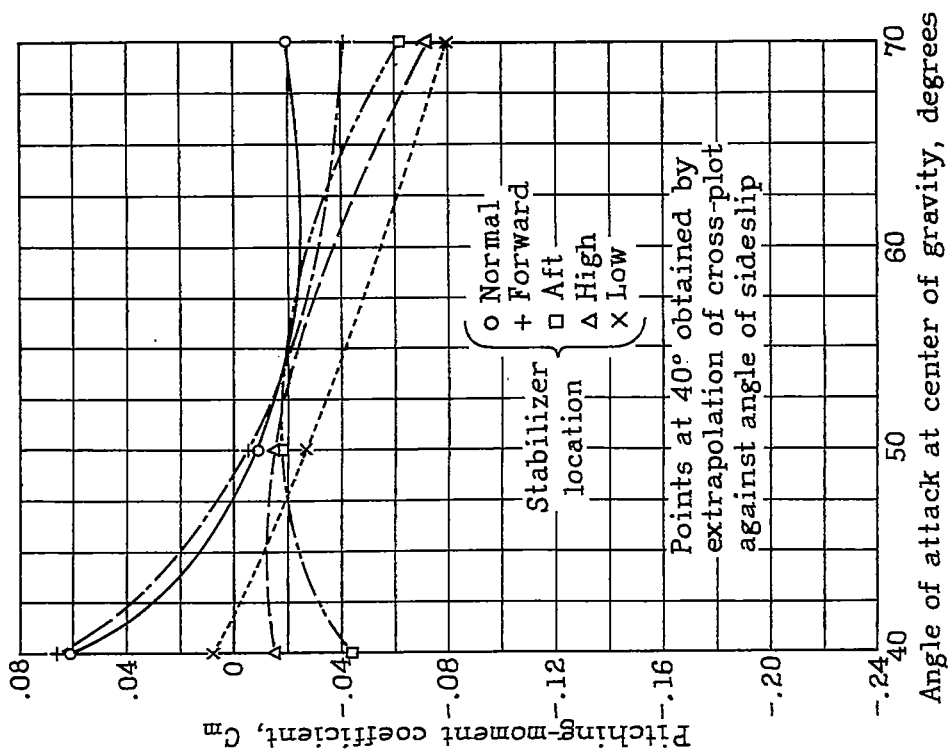

Figure 10.- Pitching-moment coefficients due to stabilizer and elevator. Sideslip at c.g. 10° (inward). C_m (controls 35° with the spin). $-C_m$ (elevator and stabilizer re-moved, rudder neutral).

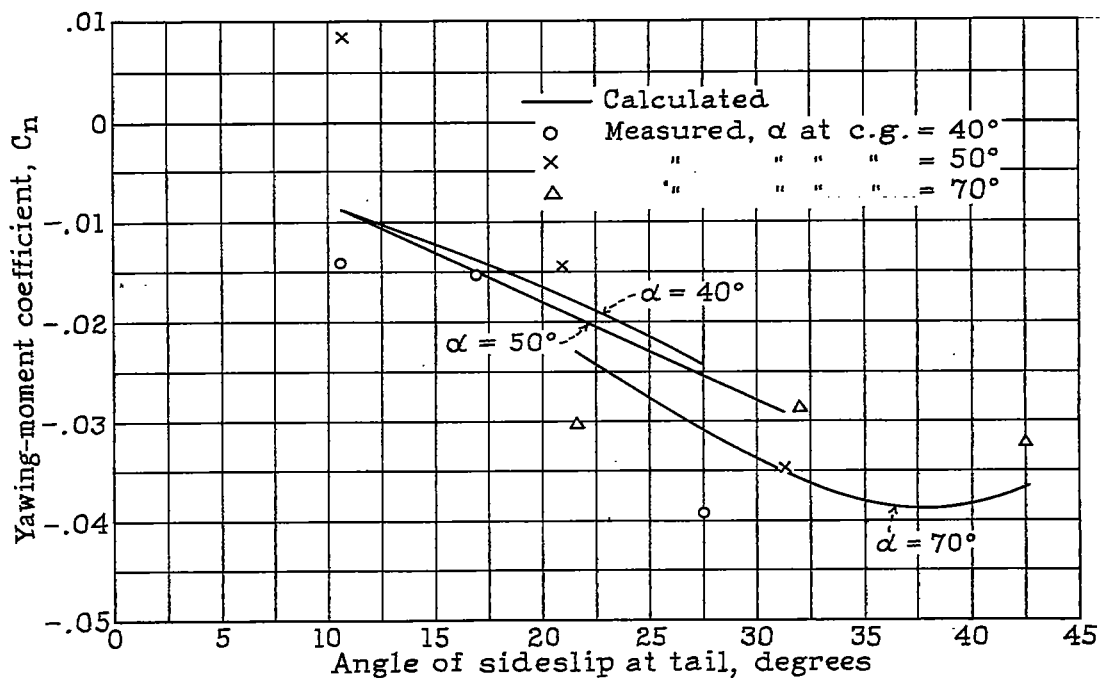

Figure 9.- Yawing-moment coefficients due to fin and rudder with stabilizer removed. Comparison of calculated and measured values.

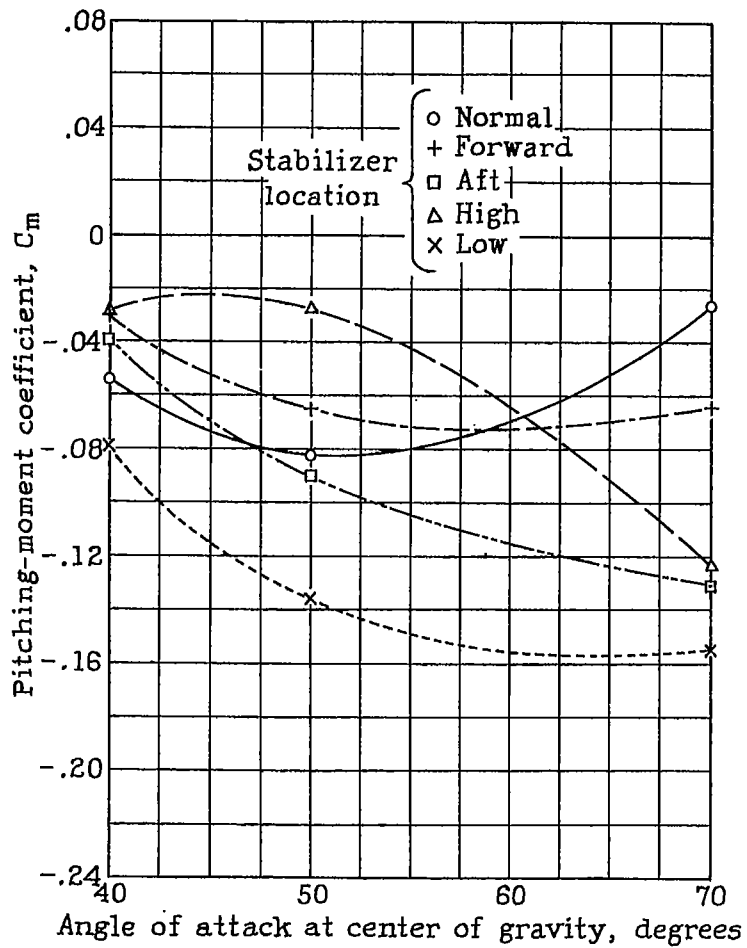

Figure 11.-Pitching-moment coefficients due to stabilizer and elevator. Sideslip at c.g. 0° . C_m (controls 35° with the spin), $-C_m$ (stabilizer & elevator removed, rudder neutral).

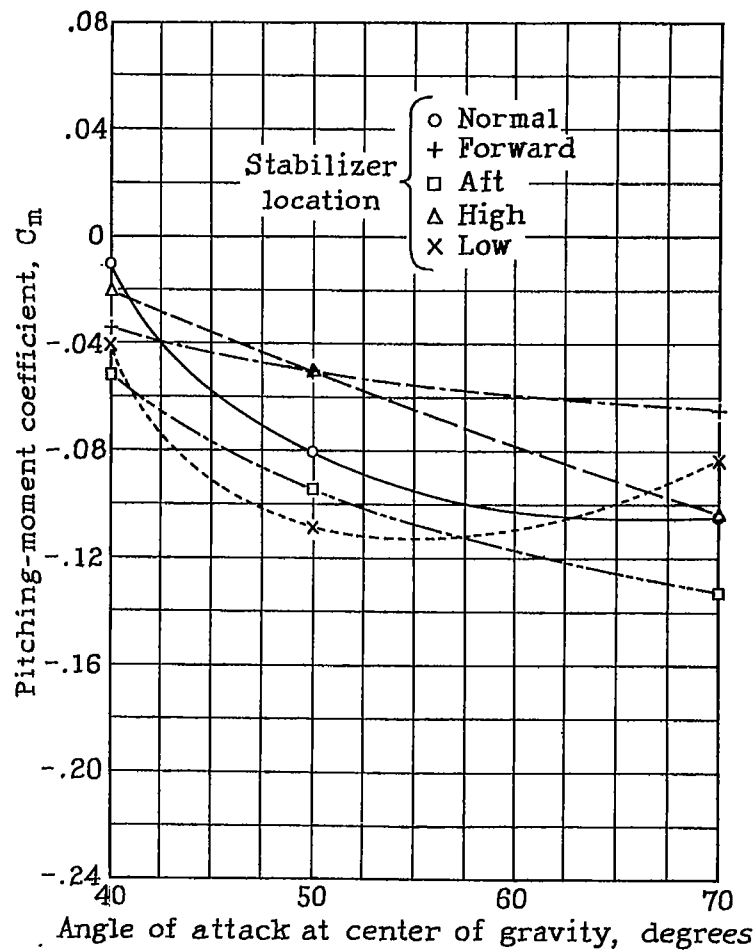

Figure 12.-Pitching-moment coefficients due to stabilizer and elevator. Sideslip at c.g. -10° (outward). C_m (controls 35° with the spin), $-C_m$ (stabilizer & elevator removed, rudder neutral).

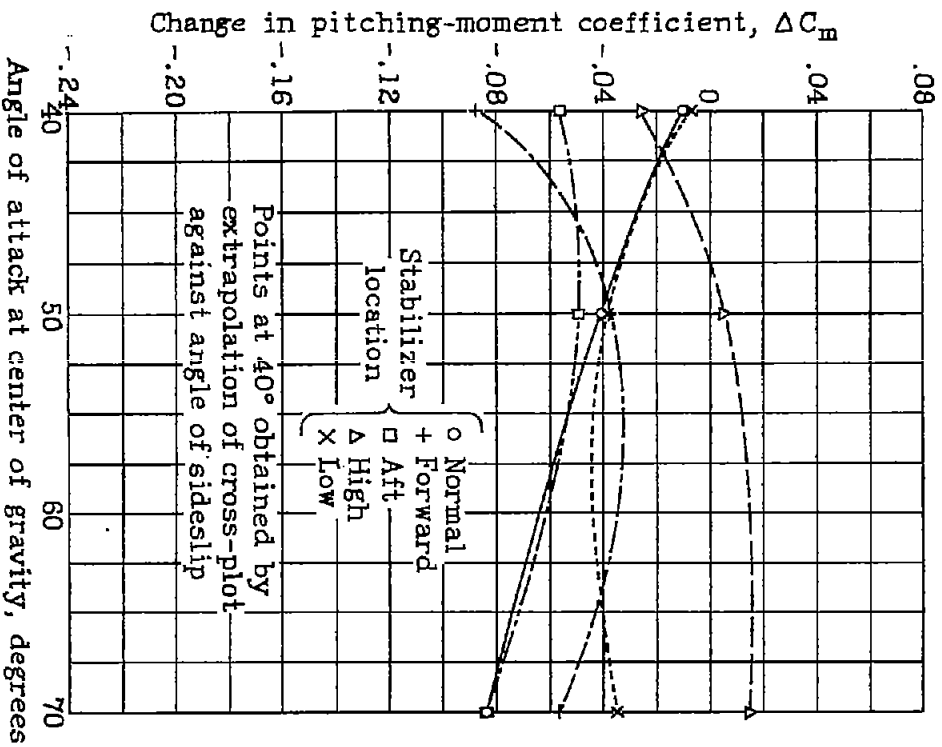

Figure 13.- Change in pitching-moment coefficients due to control movement. Sideslip at c.g. 10° (inward). C_m (controls neutral) - C_m (controls 35° with the spin).

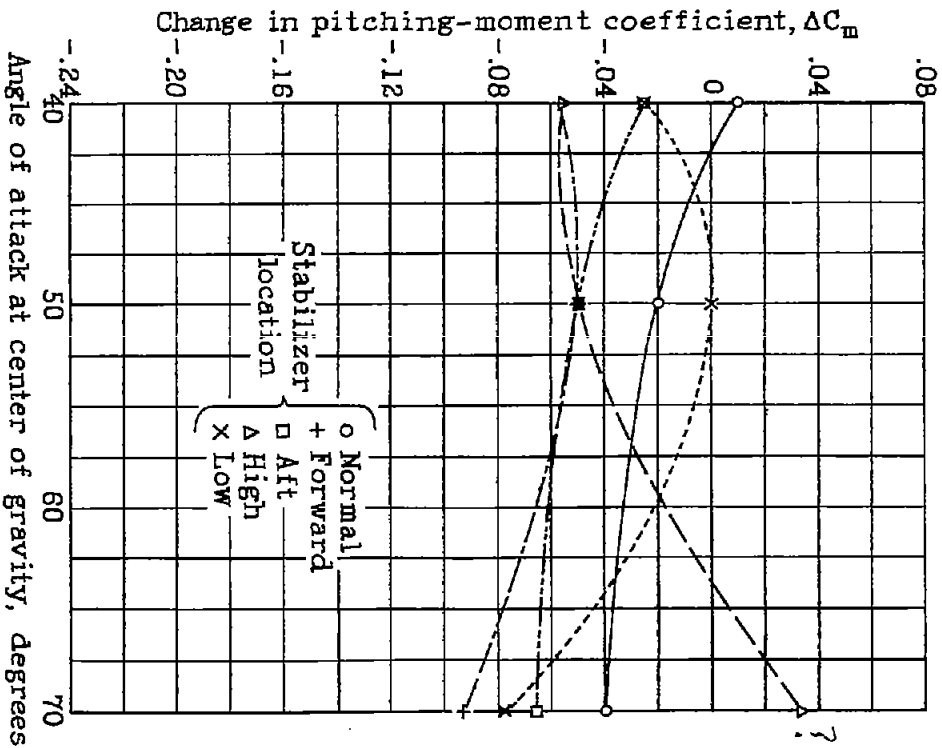

Figure 14.- Change in pitching-moment coefficients due to control movement. Sideslip at c.g. 0°. C_m (controls neutral) - C_m (controls 35° with the spin).

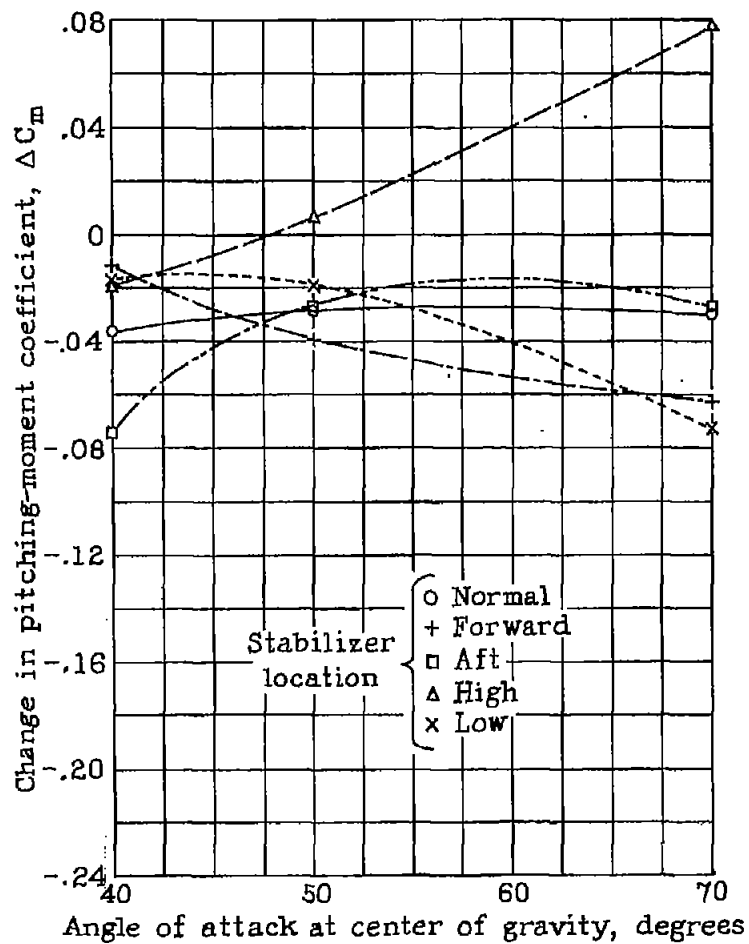

Figure 15.- Change in pitching-moment coefficients due to control movements. Sideslip at c.g. 10° (outward). C_m (controls neutral) $-C_m$ (controls 35° with the spin).

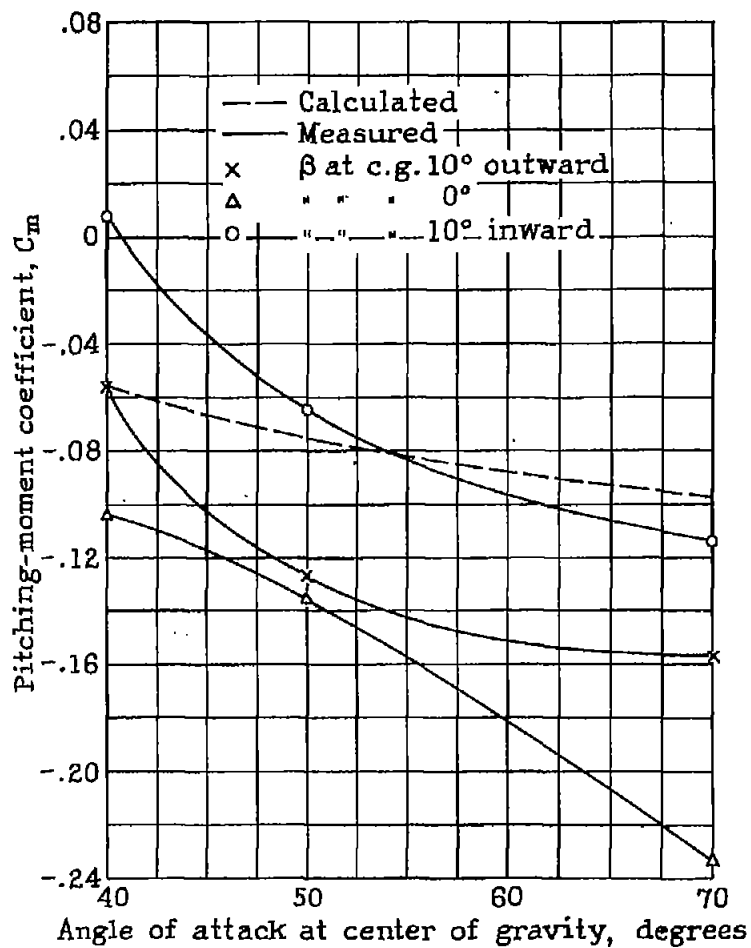

Figure 16.- Pitching-moment coefficients due to stabilizer and elevator, with stabilizer and elevator located at bottom of fuselage. Comparison of calculated and measured values.