

FILE COPY  
NO. 8

# CASE FILE COPY

TECHNICAL NOTES

NATIONAL ADVISORY COMMITTEE FOR AERONAUTICS

-----  
No. 711  
-----

AN APPROXIMATE SPIN DESIGN CRITERION FOR MONOPLANES

By Oscar Seidman and Charles J. Donlan  
Langley Memorial Aeronautical Laboratory

THIS DOCUMENT ON LOAN FROM THE FILES OF

NATIONAL ADVISORY COMMITTEE FOR AERONAUTICS  
LANGLEY AERONAUTICAL LABORATORY  
LANGLEY FIELD, HAMPTON, VIRGINIA

-----  
RETURN TO THE ABOVE ADDRESS.

REQUESTS FOR PUBLICATIONS SHOULD BE ADDRESSED  
AS FOLLOWS:

NATIONAL ADVISORY COMMITTEE FOR AERONAUTICS  
1724 F STREET, N.W.,  
WASHINGTON 25, D.C.

Washington  
June 1939

NATIONAL ADVISORY COMMITTEE FOR AERONAUTICS

-----  
TECHNICAL NOTE NO. 711  
-----

AN APPROXIMATE SPIN DESIGN CRITERION FOR MONOPLANES

By Oscar Seidman and Charles J. Donlan

SUMMARY

A quantitative criterion of merit has been needed to assist airplane designers to incorporate satisfactory spinning characteristics into new designs. An approximate empirical criterion, based on the projected side area and the mass distribution of the airplane, has been formulated in a recent British report. In the present paper, the British results have been analyzed and applied to American designs. A simpler design criterion, based solely on the type and the dimensions of the tail, has been developed; it is useful in a rapid estimation of whether a new design is likely to comply with the minimum requirements for safety in spinning.

INTRODUCTION

A considerable amount of information concerning the effects of dimensional and inertial design characteristics exists in the literature on spinning. In general, however, the data are so presented that they are not directly and quantitatively applicable to new designs. There is need for a satisfactory quantitative criterion to indicate whether a new design is likely to comply with the minimum requirements for safety in spinning.

Such a criterion is developed in a recent British publication (reference 1). The present report is concerned with the application of the British criterion to American airplanes. An analysis of the results is presented and a simplified criterion of spinning merit developed that, as far as American designs are concerned, conforms better with full-scale and model spinning data than the original English criterion.

## BASIS OF ENGLISH CRITERION

The complete development of the British criterion is given in detail in reference 1. The basic considerations underlying the development are reviewed briefly in the following paragraphs.

The spinning characteristics of an airplane are considered to be affected by three major design factors. These factors are:

- (1) The longitudinal distribution of mass as measured by the difference  $I_z - I_x$  and expressed nondimensionally as  $\frac{I_z - I_x}{\rho S (b/2)^3}$ , where  $I_z$  and  $I_x$  are the moments of inertia about the Z and X body axes, respectively;  $\rho$  is the density of the air; S, the wing area; and  $b/2$ , the semi-span. The value of air density,  $\rho$ , used in this report is that corresponding to 15,000 feet standard altitude.
- (2) The resistance offered by the fuselage side area (exclusive of the rudder) while the airplane is spinning, which is measured by  $\sum Ax^2$ , where A is an elementary area located at a distance x from the center of gravity of the airplane. Because of its greater effectiveness, the area beneath the horizontal tail plane is multiplied by 2. (For conventional tail planes, this area is measured between the most forward and the most rearward portions of the tail plane.) The resistance of the fuselage to rotation is expressed in the form of a nondimensional "body damping ratio," defined as  $\frac{\sum Ax^2}{S (b/2)^2}$ , where S and  $b/2$  denote the wing area and the semispan, respectively.
- (3) The unshielded rudder area, expressed nondimensionally as an "unshielded rudder volume coefficient" is equal to  $\frac{\text{unshielded rudder area} \times l}{S (b/2)}$ , where  $l$  is the distance from the centroid of the unshielded rudder area to the center of gravity of the airplane.

In the computation of the body damping ratio (BDR) and the unshielded rudder volume coefficient (URVC), it was assumed that the relative wind strikes the horizontal tail surfaces from below at an angle of  $45^\circ$  and that the air flow diverges  $\pm 15^\circ$  after passing the tail plane. (This assumption regarding the divergence of the air flow above the tail plane is verified by the flight tests described in reference 2.) Any area of the vertical tail within this divergent wake is disregarded in the computations. Figure 1 illustrates the method used in evaluating BDR and URVC.

A "damping-power factor" (DPF) is defined as the product BDR  $\times$  URVC, and this factor is plotted against the pitching parameter  $\frac{I_Z - I_X}{\rho S (b/2)^3}$ . The relative magnitude of the slope,  $\frac{(DPF) [\rho S (b/2)^3]}{I_Z - I_X}$ , is used by the British as a figure of merit.

#### COMPARISON OF BRITISH AND AMERICAN RESULTS

Figure 2, which is taken from reference 1, is a plot of DPF against  $\frac{I_Z - I_X}{\rho S (b/2)^3}$  for the 22 British monoplane designs submitted for testing in the British free-spinning wind tunnel. The models are rated as either "passed" or "failed," depending on their ability to meet the requirements of a standard British model recovery test. In most instances where an initial design is represented as unsatisfactory, a point will be found representing the final modified version of that design. It is obvious from the dispersion of points that secondary factors not included in the analysis influence the ability of a model to pass the spin test. Nevertheless, a line has been drawn such that no pass point lies below it (although failures may lie above it) and defines the minimum requirement for safety in spinning. It is implied that any design the characteristic point of which lies beneath this line (i.e., for which the ratio  $\frac{(DPF) [\rho S (b/2)^3]}{I_Z - I_X}$  is less than 0.001) will probably give unsatisfactory recoveries from a spin;

whereas, if its characteristic point lies above this line, recoveries may be either satisfactory or unsatisfactory.

Figure 3 is a plot of DPF against  $\frac{I_z - I_x}{\rho S(b/2)^3}$  for 14 American monoplanes tested in the N.A.C.A. free-spinning wind tunnel. The N.A.C.A. having no unique criterion of spinning merit, the designs considered here have been denoted as being "good" or "poor" spinners, partly on the basis of spin-tunnel results and partly on the basis of pilots' reports. The fact that the English standard of recovery was not utilized in the American classification may account for the relatively greater percentage of American airplanes appearing as satisfactory spinners. It will be noted that two good points fall below the British line for minimum safety in spinning. If, however, a line (dotted line on fig. 3) is drawn through the point for airplane 1, a separation of the American airplanes is effected; this line has about one-half the slope of the British line.

#### ANALYSIS OF RESULTS

A detailed analysis of both the British and the American results was then made with the purpose of obtaining a simpler and more effective criterion.

The individual factors that constitute the British DPF are plotted in figures 4 and 5. The close grouping of points in figure 4 discourages the establishment of a spin criterion on the basis of the BDR alone. Figure 5, on the other hand, shows a greater dispersion of points and the dotted horizontal line drawn through a value of URVC of 0.013 effects a separation of passed and failed points that is comparable with the separation previously noted on the DPF chart (fig. 2). This result suggests that the URVC alone might prove as satisfactory a criterion as the more complex DPF, which necessitates the consideration of BDR and  $\frac{I_z - I_x}{\rho S(b/2)^3}$ .

It would appear that an alternative conclusion to the British report might have stated that any model possessing a value for URVC of less than 0.013 would be unlikely to pass the model spinning requirements. This condition would have eliminated the necessity of considering the body damping ratio and the inertia pitching parameter.

This discussion concludes the analysis of the British data. The rest of the report is concerned with the analysis of the results for the American monoplanes and the formulation of a criterion based on the unshielded rudder area and the fuselage area directly below the horizontal tail surfaces.

Figures 6 and 7 are plots of the factors constituting the DPF for the American monoplanes. Figure 6 could be used to segregate the good from the poor spinners but, as will be shown later, the segregation is largely attributable to the area beneath the horizontal tail surfaces and not to the BDR as a whole. In figure 7, the dotted horizontal line drawn through the value of URVC of 0.01 indicates that satisfactory separation of good and poor spinners can be obtained for the American airplanes by considering the URVC alone, although the line of separation is lower than that used for the British models in figure 5. Thus the value URVC = 0.01 might be used to separate new designs into two classifications; designs having a value of URVC less than 0.01 may be considered unlikely to pass the spinning requirements.

In reference 1, the importance of the fixed area below the horizontal tail surfaces has been recognized by arbitrarily doubling its contribution to the body damping ratio. Its influence is obscured, however, because its contribution may be small even when doubled as compared with the body damping ratio. In order further to emphasize its importance, the contribution to the body damping ratio of the fixed area below the horizontal tail surfaces has been considered separately for the American airplanes;

it is expressed as a tail damping ratio, 
$$TDR = \frac{FL^2}{S(b/2)^2}$$

where F is the total fixed area below the horizontal tail and L is the distance from the centroid of this area to the center of gravity of the airplane.

Values of the TDR for American monoplanes are shown in figure 8. It will be noted that a separation of the good from the poor spinners can be effected by using the value TDR = 0.015. Figures 7 and 8 show that the URVC and the TDR taken separately effect similar separations of the American designs into two groups. It is obvious that many possible combinations of these two factors could be used in devising an empirical criterion to segregate the poor spinners. In order to emphasize the importance of

having both unshielded rudder area and fixed area below the horizontal surfaces, it was decided to use the product  $URVC \times TDR$  as a criterion of merit. It is appreciated that the results may not be valid for unconventional designs.

Figure 9 illustrates the method used in evaluating a tail damping-power factor (TDPF) defined as the product of TDR and URVC. This TDPF is plotted in figure 10 for 14 American monoplanes and effects a satisfactory separation of good and poor spinners.

It may be concluded on the basis of figure 10 that monoplanes possessing a TDPF of less than, say, 0.00015 are not likely to exhibit satisfactory recovery characteristics. On the other hand, it is felt that a TDPF in excess of 0.00015 is, in itself, insufficient to insure satisfactory spin characteristics.

Similar results were obtained for American biplanes, but the critical value of the TDPF appeared to be somewhat lower and less distinct than for the monoplanes.

Lack of sufficient data prevented the calculation of the TDPF for the British designs.

#### DISCUSSION AND CONCLUSIONS

In the present state of knowledge, no criterion is available that will infallibly predict the recovery characteristics of a new airplane design. As shown in the text, however, it is possible to formulate empirical criteria that are helpful in establishing the minimum design requirements for safety in spinning. It is believed that the tail damping-power factor (TDPF) developed in the text is a simple practical method for rapidly estimating whether a new design is likely to comply with the minimum requirements for safety in spinning and it is recommended that no new monoplane design be constructed which possesses a TDPF of less than 0.00015. It should not be assumed, however, that a design which has a satisfactory TDPF will necessarily exhibit good recovery characteristics, as other factors not herein considered may influence the results.

Langley Memorial Aeronautical Laboratory,  
National Advisory Committee for Aeronautics,  
Langley Field, Va., May 1, 1939.

REFERENCES

1. Finn, E.: Analysis of Routine Tests of Monoplanes in the Royal Aircraft Establishment Free Spinning Tunnel. R. & M. No. 1810, British A.R.C., 1937.
2. Scudder, N. F., and Miller, M. P.: The Nature of Air Flow about the Tail of an Airplane in a Spin. T.N. No. 421, N.A.C.A., 1932.

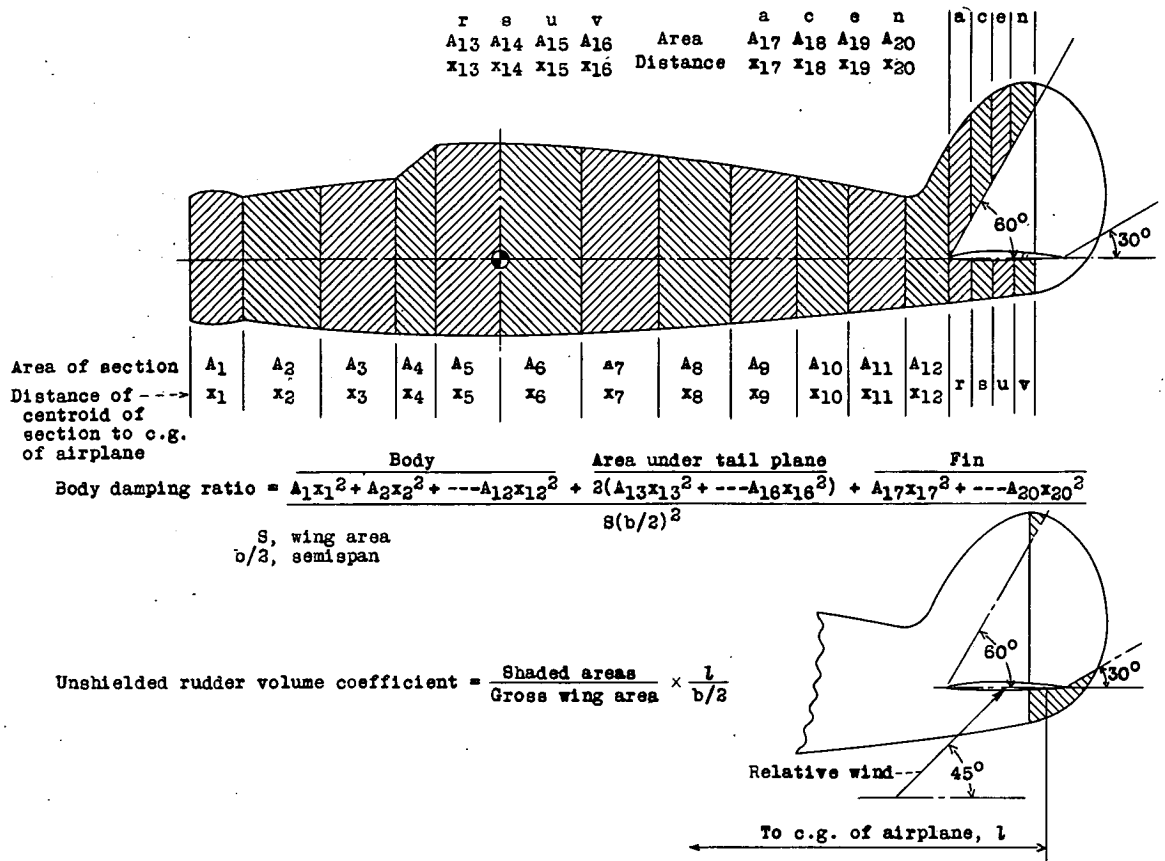

Figure 1.- Method of computation of damping coefficients.

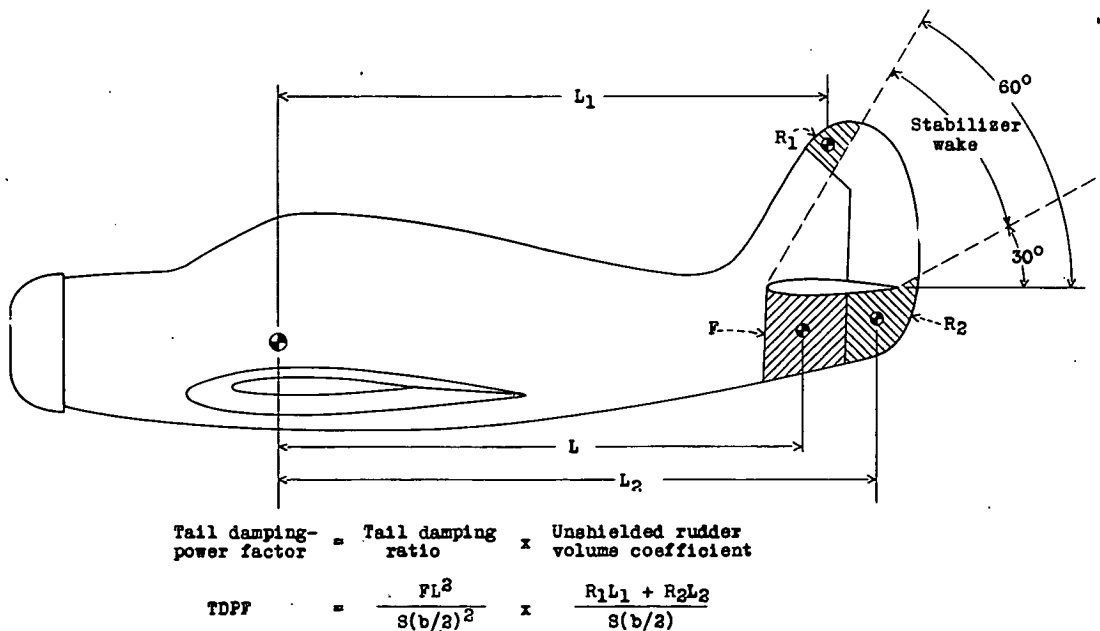

Figure 9.- Method of computing tail damping-power factor.

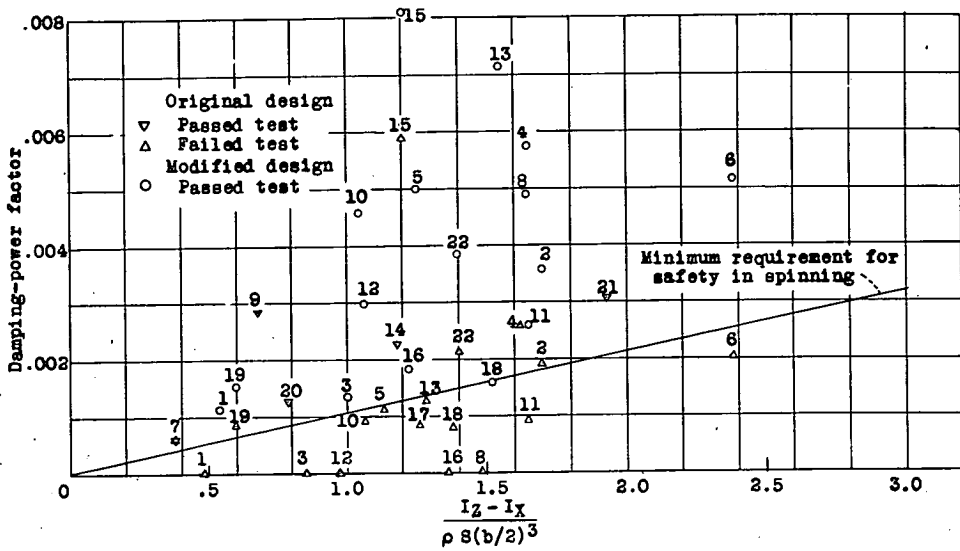

Figure 2.- Variation of damping-power factor with inertia pitching parameter for 22 British monoplanes (From reference 1).

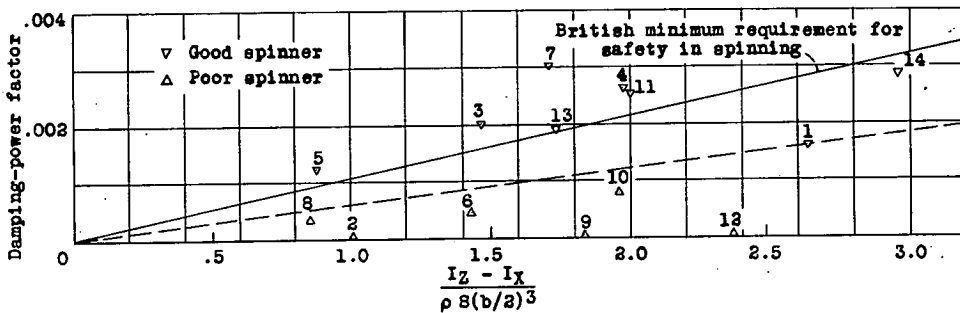

Figure 3.- Variation of damping-power factor with inertia pitching parameter for 14 American monoplanes.

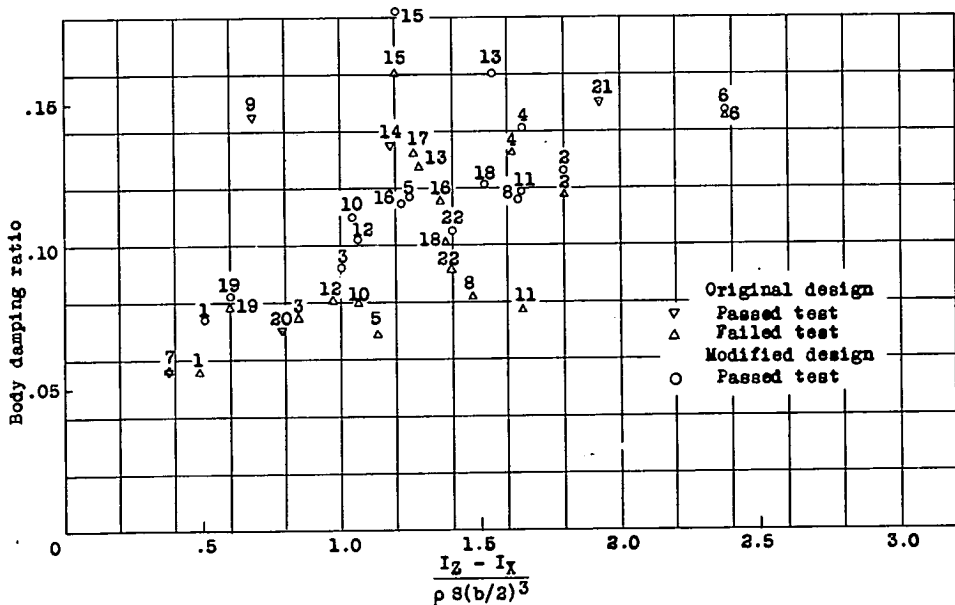

Figure 4.- Variation of body damping ratio with inertia pitching parameter for 22 British monoplanes (From reference 1).

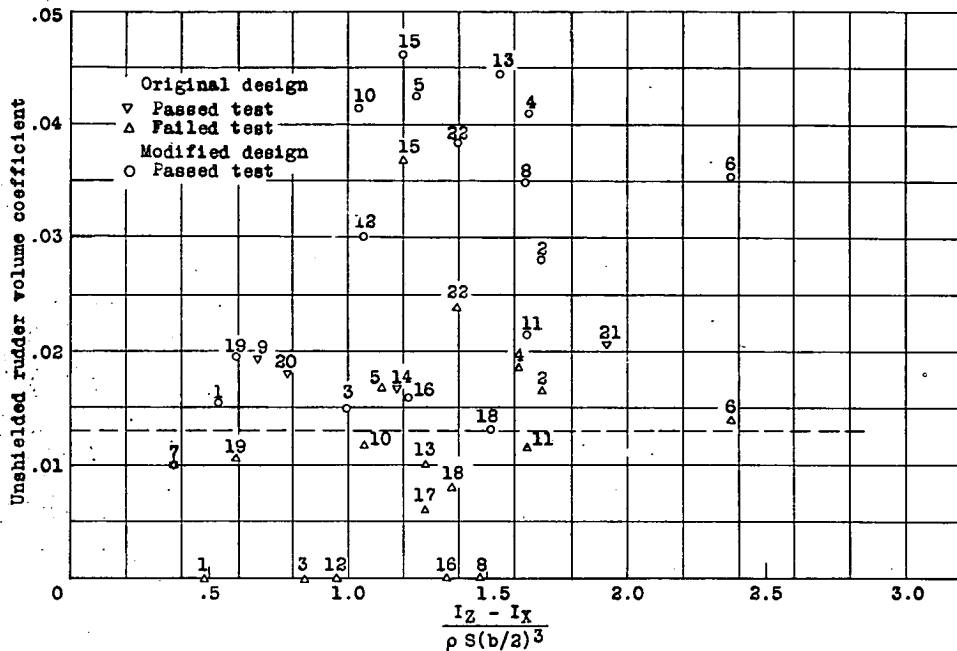

Figure 5.- Variation of unshielded rudder volume coefficient with inertia pitching parameter for 22 British monoplanes (From reference 1).

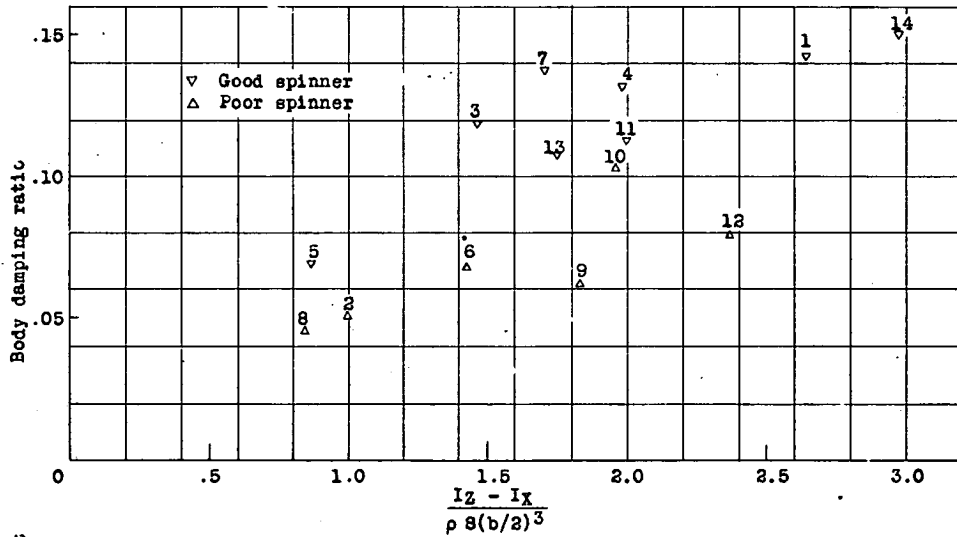

Figure 6.- Variation of body damping ratio with inertia pitching parameter for 14 American monoplanes.

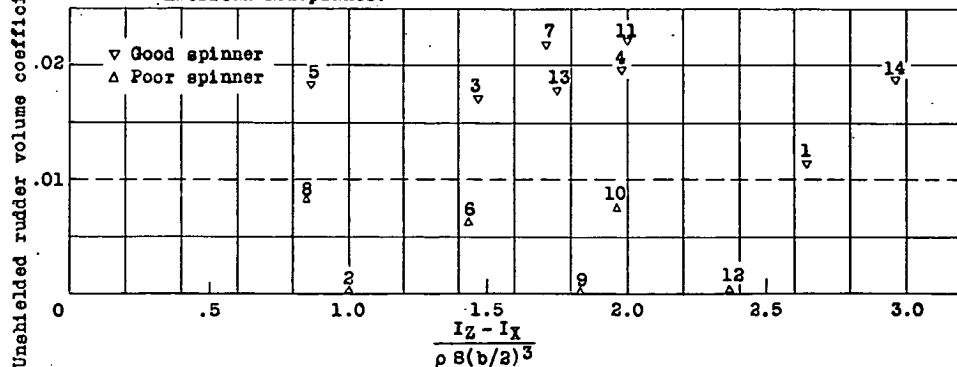

Figure 7.- Variation of unshielded rudder volume coefficient with inertia pitching parameter for 14 American monoplanes.

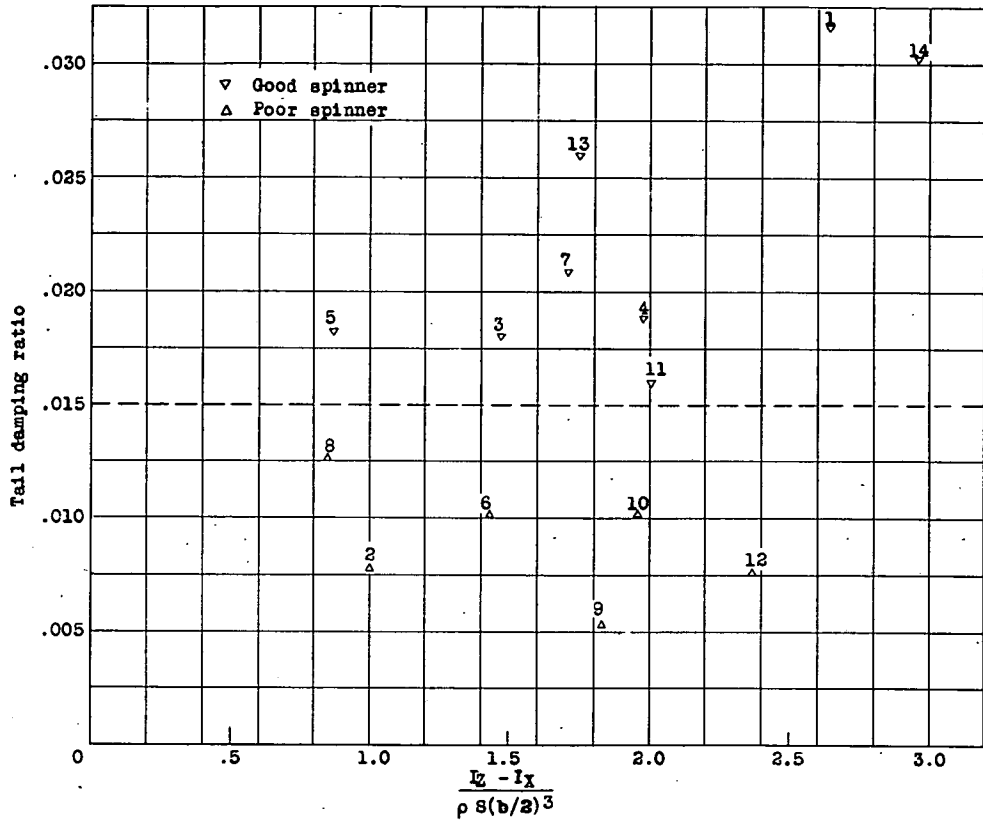

Figure 8.- Variation of tail damping ratio with inertia pitching parameter for 14 American monoplanes.

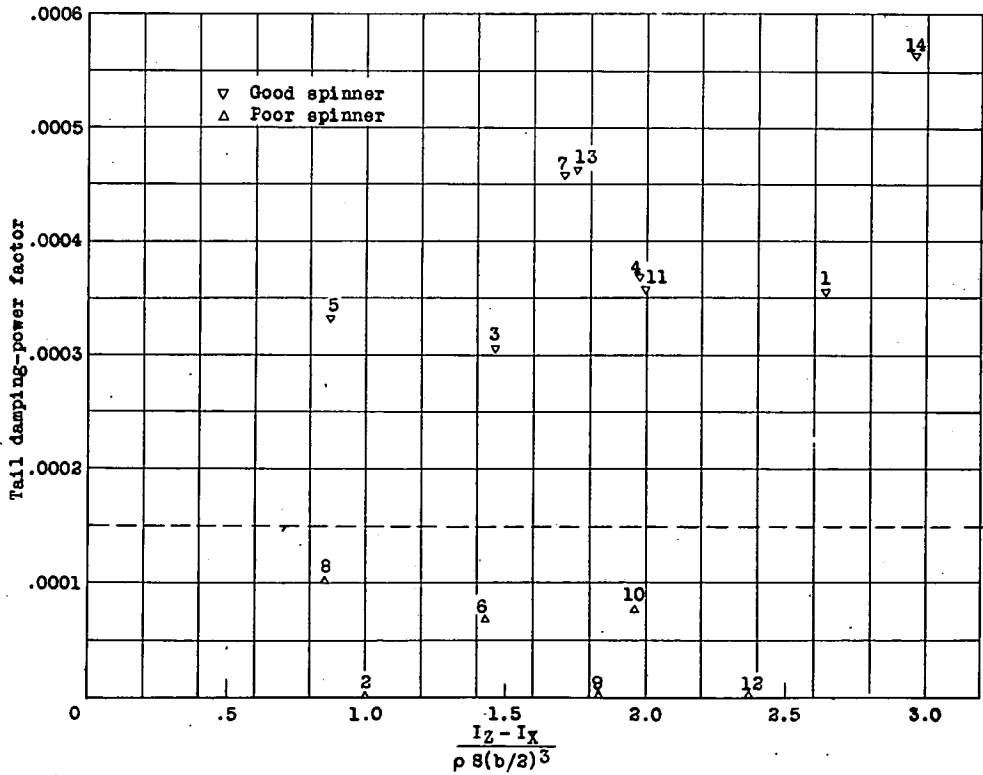

Figure 10.- Variation of tail damping-power factor with inertia pitching parameter for 14 American monoplanes.