

NATIONAL ADVISORY COMMITTEE FOR AERONAUTICS

TECHNICAL NOTE

No. 1452

AN INVESTIGATION OF AIRCRAFT HEATERS

TECHNICAL LIBRARY
AIRESEARCH MANUFACTURING CO.
9851-9951 SEPULVEDA BLVD.
INGLEWOOD,
CALIFORNIA
11-1-48

XXVIII - EQUATIONS FOR STEADY-STATE TEMPERATURE DISTRIBUTION

CAUSED BY THERMAL SOURCES IN FLAT PLATES APPLIED TO
CALCULATION OF THERMOCOUPLE ERRORS, HEAT-METER
CORRECTIONS, AND HEAT TRANSFER BY PIN-FIN PLATES

By L. M. K. Boelter, F. E. Romie,
A. G. Guibert, and M. A. Miller

University of California



Washington

August 1948

NATIONAL ADVISORY COMMITTEE FOR AERONAUTICS

TECHNICAL NOTE NO. 1452

AN INVESTIGATION OF AIRCRAFT HEATERS

XXVIII - EQUATIONS FOR STEADY-STATE TEMPERATURE DISTRIBUTION

CAUSED BY THERMAL SOURCES IN FLAT PLATES APPLIED TO

CALCULATION OF THERMOCOUPLE ERRORS, HEAT-METER CORRECTIONS,

AND HEAT TRANSFER BY PIN-FIN PLATES

By L. M. K. Boelter, F. E. Romie,
A. G. Guibert, and M. A. Miller

SUMMARY

The equation for steady-state temperature distribution caused by a thermal source (or sink) in a flat plate surrounded on either side by fluids of different temperature is developed and applications are presented in three sections in this report. The applications are as follows:

- (a) A thermal error which occurs when thermocouples are used for the measurement of plate temperatures is described, and an analytical prediction of this error is obtained.
- (b) A determination is made of the effect on heat-transfer rate in pin-fin plates due to the thermal conductivity and thickness of the plate metal.
- (c) The temperature-distribution equation is applied to the heat meter and a correction factor is obtained which includes consideration of the effect produced by the flow of heat "around" the heat meter.

INTRODUCTION

This report describes techniques involved in making certain thermal measurements which are necessary in the analysis of heating problems in aircraft and contains the general solution for the determination of the steady-state temperature distribution caused by thermal sources (or sinks) in plates surrounded on either side by fluids of different temperature. The terms "source" and "sink" are used to denote a means of adding heat to or subtracting it, respectively, from a substance. As is shown later, thermocouple leads and fins may be considered to be

sources or sinks of heat. The first application of the solution is to the calculation of the thermal error of thermocouple temperature indications when the thermocouple is employed to measure plate temperatures.

Accurate measurements of surface temperatures are useful in determining local heat-transfer rates, for instance, in an exhaust-gas air heater or along an airfoil surface and in evaluating thermal stresses and temperature distributions which are criterions of the stability and life of a heater unit.

The analytical approach to the determination of a thermal error considers the junction of the thermocouple in the plate to be a thermal source (or sink depending on whether the thermocouple leads are exposed to the hotter or colder fluid). The physical system can be visualized best by focusing attention on the case for which the leads are exposed to the hotter fluid. The thermocouple leads, in this case, are at a higher temperature than the plate because they are not being cooled by exposure to a cooler fluid as is the plate. Consequently, heat will flow through the leads to the plate thus increasing the temperature of the thermocouple junction and the plate in the immediate vicinity of the junction, which thus acts as a heat source. The thermal error of the thermocouple is defined as the difference in the temperature of the thermocouple junction and that of the plate far away (or the equivalent, the temperature at any point of the plate in the absence of the thermocouple). This thermal error is not to be confused with electrical, metallurgical, method of attachment, or other errors to which thermocouples are subject.

The general solution is also applied, in this report, to the calculation of the effect of plate thermal conductivity on heat-transfer rates for pin-fin plates. Ordinarily the thermal conductivity of a thin metallic plate is so large compared with the convective conductances on either side that the thermal resistance of the plate can be neglected in heat-rate calculations. When pin fins are present, however, conditions may be obtained that promote heat flow radially in the plate from the pin bases. Under these conditions the thermal conductivity of the plate can become an important factor in some cases. The equations which allow calculation of heat rates in pin-fin plates of finite resistance are developed and these are compared with the usual equations for heat-transfer rates in pin-fin plates which postulate infinite thermal conductivity of the plate.

In a third application the solution is applied to the determination of a correction factor for a heat meter when the meter is used to measure the heat rate through a plate. The correction factors presented before (references 1 and 2) have postulated that all heat flows through the plate and the meter in the direction normal to their surfaces.

This condition does not result when the thermal conductivity of the plate or the plate thickness is large and conditions are such that a part of the heat flow occurs parallel to the plate surface into or out of the metal directly under the meter. The equation for the correction factor presented in this report takes cognizance of this latter condition.

Experimental verification of the conclusions reached by means of the analyses presented in this report are lacking. An experimental program is being planned, however, which will allow verification of these conclusions.

This work was conducted at the University of California under the sponsorship and with the financial assistance of the National Advisory Committee for Aeronautics.

SYMBOLS

A	area of heat transfer, square feet
A_x	cross-sectional area of pin fin or thermocouple lead, square feet
A_u	unfinned area of pin-fin plate, square feet
a	distance between in-line pins, feet
b	thickness of plate, feet
C_1, C_2	constants
f	unit thermal convective conductance, $\text{Btu}/(\text{hr})(\text{sq ft})(^\circ\text{F})$
f_e	equivalent unit thermal conductance for flow of fluid over insulated thermocouples, $\text{Btu}/(\text{hr})(\text{sq ft})(^\circ\text{F})$
f_h	unit thermal convective conductance over surface of heat meter, $\text{Btu}/(\text{hr})(\text{sq ft})(^\circ\text{F})$
$I_0(x)$	modified Bessel function of the first kind, zero order
$I_1(x)$	modified Bessel function of the first kind, first order
$K_0(x)$	modified Bessel function of the second kind, zero order (for a discussion of the rotation used for Bessel functions, see appendix)
$K_1(x)$	modified Bessel function of the second kind, first order
k	thermal conductivity, $\text{Btu}/(\text{hr})(\text{sq ft})(^\circ\text{F}/\text{ft})$
k_e	equivalent thermal conductivity, $\text{Btu}/(\text{hr})(\text{sq ft})(^\circ\text{F}/\text{ft})$
L	length of pin fin, feet

P	circumferential perimeter of pin fin or thermocouple wire, feet
q	heat-transfer rate, Btu/(hr)
q ₀	heat-transfer rate through plate in absence of heat meter, Btu/(hr)
r	radial distance from source center, feet
r _s	radius of source (or sink), feet
r _T	radius of thermocouple lead, feet
R _c	thermal contact resistance (defined by $q = \frac{\Delta t_c}{R_c}$), (hr)(°F)/Btu
τ	temperature of fluid, °F
t	temperature of plate, °F
t _b	temperature in pin-fin plate at base of pin, °F
t _∞	temperature that plate would obtain in absence of source or at infinite distance from source (defined by equation (8)), °F
α	equivalent to thermal conductance (defined in equations (14) and (15)), Btu/(hr)(°F)
β	defined by equation (10), 1/(sq ft)
δ	thickness of an insulating disk (heat meter) placed over the source, feet; also thickness of insulation around thermocouple leads, feet

Subscripts:

1, 2	two thermocouple leads
p ₁ , p ₂	two opposite sides of plate
s	source
m	heat meter

ANALYSIS OF FLAT-PLATE TEMPERATURE DISTRIBUTION

The temperature distribution and heat transfer caused by a thermal source or sink on a thin flat plate surrounded on either side by fluids

of different temperature can be approximated by an ideal system which is defined by the following postulates:

(1) That section of the plate occupied by the source (or sink) is circular and of infinite thermal conductivity (that is, the section is at uniform temperature)

(2) The plate has infinite thermal conductivity in the direction normal to its surface (that is, there is no temperature gradient normal to the plate surface at any point)

(3) The temperature of the fluid on each side of the plate is uniform and constant (steady state)

(4) The unit thermal convective conductances of the fluids are uniform over the plate surface

Because it can be shown that the form of the solution will be independent of whether the temperature distribution is caused by a source or a sink, the distribution will be considered, for convenience, as being due to a source. Similarly, one specific side of the plate will be considered to be in contact with a hot fluid and the other side in contact with a cold fluid, even though the analysis can be carried through without knowledge of the direction of the heat flow.

The solution is obtained by making a heat-rate balance on a differential annulus of radius r and width dr which is concentric with the source center. (Refer to fig. 1.)

A heat balance on the differential annulus consists of the following terms:

The heat flowing in the plate radially from the source into the annulus

$$q_r = -kA \left(\frac{dt}{dr} \right)_r = -2\pi r b k \left(\frac{dt}{dr} \right)_r \quad (1)$$

The heat flowing in the plate radially from the source leaving the outer rim of the annulus

$$q_{r+dr} = -kA \left(\frac{dt}{dr} \right)_{r+dr} = -2\pi k b \left[r \frac{dt}{dr} + \frac{d}{dr} \left(r \frac{dt}{dr} \right) dr \right] \quad (2)$$

The heat flowing into the top of the annulus from the hot fluid

$$q_1 = f_{p_1} A(\tau_1 - t) = f_{p_1} 2\pi r dr(\tau_1 - t) \quad (3)$$

The heat flowing out of the bottom of the annulus into the cold fluid

$$q_2 = f_{p_2} A(t - \tau_2) = f_{p_2} 2\pi r dr(t - \tau_2) \quad (4)$$

The steady-state condition has been postulated so that it is possible to equate the heat flowing into the annulus to the heat leaving the annulus; thus

$$q_r + q_1 = q_{r+dr} + q_2 \quad (5)$$

Substitution of equations (1) to (4) into equation (5) gives

$$2\pi kb \frac{d}{dr} \left(r \frac{dt}{dr} \right) dr = 2\pi r dr \left[f_{p_2} (t - \tau_2) - f_{p_1} (\tau_1 - t) \right] \quad (6)$$

Rearrangement and simplification of equation (6) gives

$$r^2 \frac{d^2 t}{dr^2} + r \frac{dt}{dr} - \frac{f_{p_1} + f_{p_2}}{bk_p} r^2 \left(t - \frac{f_{p_1} \tau_1 + f_{p_2} \tau_2}{f_{p_1} + f_{p_2}} \right) = 0 \quad (7)$$

The term $\frac{f_{p_1} \tau_1 + f_{p_2} \tau_2}{f_{p_1} + f_{p_2}}$, which will be denoted by t_∞ , represents

the temperature which the plate would attain in the absence of the source, (that is, the temperature of the plate at an infinite distance from the source). Thus $t - t_\infty$ is the rise in temperature of the plate at any point due to the presence of the source.

When a new variable is defined

$$t' = t - \frac{f_{p_1} \tau_1 + f_{p_2} \tau_2}{f_{p_1} + f_{p_2}} = t - t_\infty \quad (8)$$

and it is noted that

$$\frac{dt^*}{dr} = \frac{dt}{dr} \quad \text{and} \quad \frac{d^2t^*}{dr^2} = \frac{d^2t}{dr^2}$$

the form of equation (7) can be changed giving

$$r^2 \frac{d^2t^*}{dr^2} + r \frac{dt^*}{dr} - \beta r^2 t^* = 0 \quad (9)$$

where

$$\beta = \frac{f_{p1} + f_{p2}}{bk_p} \quad (10)$$

This differential equation (9) is a modified Bessel equation for which the solution (reference 3) is

$$t^* = C_1 I_0(\sqrt{\beta}r) + C_2 K_0(\sqrt{\beta}r) \quad (11)$$

In the determination of the constant C_1 it can be observed that the increase in plate temperature ($t^* = t - t_\infty$), due to the presence of the source, must approach zero as r increases. As a result, the constant C_1 must be equal to zero because the function I_0 approaches infinity as the argument approaches infinity. Thus the final solution is

$$t^* = C_2 K_0(\sqrt{\beta}r) \quad (12)$$

or

$$t - t_\infty = C_2 K_0(\sqrt{\beta}r) \quad (13)$$

In the evaluation of the constant C_2 it is necessary to define the source more completely than it is defined by the conditions given in the postulates. The most commonly met source will be described by the following conditions: (The simplifying assumptions regarding direction of heat flow are retained.)

1. Heat flow into the source from the hot fluid can be expressed by an equation of the form

$$q_{s1} = \alpha_1(\tau_1 - t_s) \quad (\alpha_1 = \text{Constant}) \quad (14)$$

where t_s is the temperature of the source

2. The heat flow out of the source into the colder fluid can be expressed by an equation of the form

$$q_{s2} = \alpha_2(t_s - \tau_2) \quad (\alpha_2 = \text{Constant}) \quad (15)$$

Equations for the conductances α_1 and α_2 are presented in table I for several physical systems.

The difference between the heat entering and leaving the surfaces of the source disk is the heat conducted into the plate.

$$q_{s1} - q_{s2} = -kA \left(\frac{dt}{dr} \right)_{r=r_s} = -2\pi r_s b k \frac{d}{dr} \left[C_2 K_0(\sqrt{\beta} r) \right]_{r=r_s} \quad (16)$$

This equality becomes

$$\alpha_1(\tau_1 - t_s) - \alpha_2(t_s - \tau_2) = 2\pi r_s b k C_2 \sqrt{\beta} K_1(\sqrt{\beta} r_s) \quad (17)$$

Substituting $t_s = t_\infty + t'_s$ and solving for C_2 gives

$$C_2 = \frac{\alpha_1(\tau_1 - t_\infty) + \alpha_2(\tau_2 - t_\infty)}{K_0(\sqrt{\beta} r_s)(\alpha_1 + \alpha_2) + 2\pi r_s b k \sqrt{\beta} K_1(\sqrt{\beta} r_s)} \quad (18)$$

The following material presented will concern itself with the three principal applications of the solutions given here in the order given below:

- (a) Determination of thermocouple error
- (b) Heat transfer in pin-fin plates
- (c) Determination of correction factors for heat meters

DETERMINATION OF THERMOCOUPLE ERROR

The determination of plate temperatures by means of thermocouples presents a difficult problem whenever the thermocouple leads are subjected to a temperature different from that of the plate. Because, in general, the leads are at a temperature different from that of the plate, it is important that some method be available to estimate the resultant error in the temperature indicated by the thermocouple. The solution given in this report is easily applied to this purpose for the case in which the thermocouple leads are attached in the manner shown in figure (2).

When it is recalled that

$$t_{\infty} = \frac{f_{p1} \tau_1 + f_{p2} \tau_2}{f_{p1} + f_{p2}}$$

and the constant C_2 is written out, the solution (equation (13)) can be written as follows:

$$t_s - t_{\infty} = \frac{\alpha_1(\tau_1 - t_{\infty}) + \alpha_2(\tau_2 - t_{\infty})}{\alpha_1 + \alpha_2 + 2\pi r_s b k \sqrt{\beta} \frac{K_1(\sqrt{\beta} r_s)}{K_0(\sqrt{\beta} r_s)}} \tag{19}$$

The temperature t_s is the temperature of the thermocouple junction (the source) and thus is the temperature indicated by the thermocouple (emf measurement usually by means of a potentiometer), whereas t_{∞} can be considered as the true temperature of the plate. The difference in temperature ($t_s - t_{\infty}$) then represents the thermocouple error.

Rewriting the equation slightly and noting that $\frac{\tau_2 - t_{\infty}}{\tau_1 - t_{\infty}} = -\frac{f_{p1}}{f_{p2}}$,

gives

$$\frac{t_s - t_{\infty}}{\tau_1 - t_{\infty}} = \frac{\alpha_1 - \alpha_2 \frac{f_{p1}}{f_{p2}}}{\alpha_1 + \alpha_2 + 2\pi r_s b k \sqrt{\beta} \frac{K_1(\sqrt{\beta} r_s)}{K_0(\sqrt{\beta} r_s)}} \tag{20}$$

This equation, although an exact solution of the idealized system, is cumbersome and can be simplified with small error by introducing a few approximations.

When the convention is adopted that the thermocouple is on the side of the plate for which the variables are denoted by the subscript 1 the following simplifications can be made in equation (20). In usual practice the value of α_2 will be much less than α_1 (table I, systems 4 and 5) and terms including α_2 may be eliminated without introducing much error; therefore, equation (20) can be written

$$\frac{t_s - t_\infty}{t_1 - t_\infty} = \frac{1}{1 + \frac{2\pi r_s}{\alpha_1} bk\sqrt{\beta} \frac{K_1(\sqrt{\beta}r_s)}{K_0(\sqrt{\beta}r_s)}} \quad (21)$$

Two further simplifications can be made. Reference 3 gives asymptotic approximations of $K_1(x)$ and $K_0(x)$ as $x \rightarrow 0$.

$$K_1(x) \approx \frac{1}{x} \quad x < 0.05 \quad (22)$$

$$K_0(x) \approx -\log_e\left(\frac{x}{2}\right) - 0.577 \quad x < 0.05 \quad (23)$$

For the second simplification, α_1 can be written as (see table I, systems 4 and 5)

$$\alpha_1 = \sqrt{f_e P_1 k_1 A x_1} + \sqrt{f_e P_2 k_2 A x_2} \quad (24)$$

For thermocouple leads of equal diameter this conductance reduces to

$$\alpha_1 = \pi r_1 \sqrt{2f_e r_1} (\sqrt{k_1} + \sqrt{k_2}) \quad (25)$$

If an equivalent thermal conductivity k_e is defined as

$$\sqrt{k_e} = \frac{\sqrt{k_1} + \sqrt{k_2}}{2} \quad (26)$$

the equation can be further simplified to

$$\alpha_1 = 2\pi r_1 \sqrt{2f_e k_e r_t} \tag{27}$$

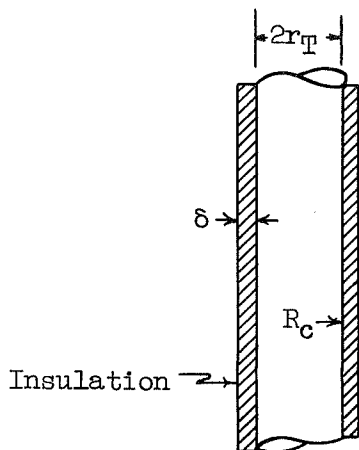

For the case of a bare thermocouple lead the term f_e is simply the average unit thermal conductance f_1 for flow over a small wire. The equivalent unit thermal conductance for radiation should always be included in f_1 . When the leads are covered by insulation of thickness δ and thermal conductivity k and when a thermal resistance R_c exists between the wire and the insulation, the term f_e is written to include these items as

Insulated thermocouple lead.

$$\frac{1}{f_e} = \frac{1}{f_1} + \frac{\delta}{k} + R_c A \tag{28}$$

where A is the heat-transfer area over which the thermal resistance R_c applies. Combining the foregoing simplifications and noting that for equal diameters of the thermocouple leads $\sqrt{2}r_T = r_s$ results in the following equation:

$$\frac{t_s - t_\infty}{\tau_1 - t_\infty} = \frac{1}{1 + \frac{R_p b}{r_T \sqrt{2f_e k_e r_T} \left(-\log_e \frac{\sqrt{\beta} r_s}{2} - 0.577 \right)}} \tag{29}$$

For small values of $\frac{t_s - t_\infty}{\tau_1 - t_\infty}$, the term in the denominator is large compared

with 1; therefore

$$\frac{t_s - t_\infty}{\tau_1 - t_\infty} \approx \frac{r_T \sqrt{2f_e k_e r_T}}{k_p b} \left[-\log_e \left(\frac{\sqrt{\beta} r_T}{2} \right) - 0.577 \right] \tag{30}$$

This equation can be used with small error for values of $\frac{t_s - t_\infty}{t_1 - t_\infty}$ less than 0.10. For larger values the more exact equations (20) or (21) should be used.

Curves of thermocouple error for four combinations of thermocouple lead size and the product of plate thermal conductivity and plate thickness are given in figures 3, 4, and 5. The curves were calculated using equation (21).

These curves indicate that the unit thermal convective conductances over the plate (f_{p1} and f_{p2}) have small effect on the thermocouple error, whereas the error is sensitive to the equivalent unit thermal conductance over the thermocouple leads. This fact brings out the great importance of proper insulation of the thermocouple leads. It is equally apparent that whenever possible, the equivalent thermal conductivity k_e of the thermocouple leads and the diameter of the leads should be as small as possible.

The following table gives values of k_e for several common thermocouple leads. These equivalent conductivities are only approximate and are calculated for conductivities at room temperature. However, in view of the difficulty of accurate determination of the convective conductances, and so forth, use of these values of k_e at high temperatures should cause no hesitation.

Thermocouple	k_e $\left(\frac{\text{Btu}}{(\text{hr})(\text{sq ft})(^\circ\text{F}/\text{ft})} \right)$
Chromel-alumel	16
Copper-constantan	90
Iron-constantan	24
Platinum-point rhodium	28

An estimate of the magnitude of the thermal error encountered when an attempt is made to measure the temperature of the surface of an exhaust-gas and air heat exchanger may be gained by consideration of the following example.

It is desired to determine the temperature of a 0.030-inch-thick stainless-steel plate exposed on one side to gas at 1500° F flowing at 150 feet per second and on the other side to air at 100° F flowing at 100 feet per second. The thermocouple will be attached to the gas side of the plate and will be made of No. 28 B. & S. gage insulated chromel-alumel wire.

The unit thermal conductances of the fluids flowing over the plate, obtained by using the equations in reference 4 are

$$f_{p1} = 16.5 \text{ Btu}/(\text{hr})(\text{sq ft})(^{\circ}\text{F})$$

$$f_{p2} = 16.2 \text{ Btu}/(\text{hr})(\text{sq ft})(^{\circ}\text{F})$$

The unit thermal conductances of the fluids flowing over the thermocouple leads are determined, however, from the equation, or the graph, in reference 5 because, for the preceding case, the value of the Reynolds modulus is beyond the range of validity of the equation given in reference 4. Use of the graph in reference 5 yields, for the unit thermal conductance over the thermocouple leads:

$$f_1 = f_2 = 160 \text{ Btu}/(\text{hr})(\text{sq ft})(^{\circ}\text{F})$$

The temperature indicated by the thermocouple ordinarily would be calculated from equations (20), (21), or (30), but the solution of equation (21) for the particular system is presented in figure 3. Therefore, calculating $k_e f_e = 2190 \text{ Btu}^2/(\text{hr})(^{\circ}\text{F})(\text{ft}^3)$ and noting that $f_{p1} + f_{p2} = 32.7 \text{ Btu}/(\text{hr})(\text{sq ft})(^{\circ}\text{F})$, the ratio $t_s - t_{\infty}/\tau_1 - t_{\infty}$

is found to be 0.077 (fig. 3) from which the thermocouple error $(t_s - t_{\infty})$ is calculated to be

$$\begin{aligned} t_s - t_{\infty} &= 0.077(\tau_1 - t_{\infty}) \\ &= 0.077 \times 692 = 53^{\circ} \text{ F} \end{aligned}$$

The estimated true temperature of the plate is thus

$$t_{\infty} = t_s - 53^{\circ} \text{ F}$$

where t_s is the temperature indicated by the thermocouple.

When a thermocouple is attached to a plate and the leads are placed in thermal (not electrical) contact with the plate for several inches from the junction, the heat that flows in the leads to or from the junction, as the case may be, will be very small (due to the reduction in temperature gradient along the leads) and consequently, the thermal error should be expected to be small. However, the disturbance of flow over the leads will cause a localized increase of the unit thermal convective conductance. This will make the junction hotter or colder depending on whether the thermocouple is on the hot or cold side and

thus introduce an error of unknown magnitude. This flow disturbance may be reduced further by flattening or embedding the thermocouple wires. If the thermocouple leads in contact with the plate are placed parallel to and away from the direction of fluid flow, the installation should have a smaller thermal error than the case illustrated in figure 2.

Also, if the convective conductances along the thermocouple leads are approximately equal on both sides of the plate (hot and cold sides), the error is small providing the leads are attached to opposite sides of the plate because the heat added to the surface by the lead on the "hot-fluid side" is just balanced by that carried away by the other lead attached to the "cold-fluid side" of the plate. These solutions may be used for two purposes:

- (1) To estimate the true temperature which would exist if the thermocouple were absent from a knowledge of the temperature at the point of attachment t_s and the other terms in the equation. (If a thermocouple is present, the true temperature is given by t_∞ , the value far away from the point of attachment).
- (2) To predict the error $t_s - t_\infty$ involved for a proposed experiment when the surface temperature t_∞ and the other terms are estimated.

Remarks

In connection with the application of the equation for steady-state temperature distribution to the determination of the thermocouple error, it may be remarked that in any installation of a thermocouple the thermal error can be made small if the following precautions are observed:

- (1) The thermocouple leads should be brought out on the side of the plate where the unit thermal convective conductance over the leads will be a minimum.
- (2) The thermocouple leads should be well insulated thermally down to the point of contact with the plate.
- (3) The thermocouple leads should be made of metals having low thermal conductivities.
- (4) The thermocouple leads should be of small-diameter wire.
- (5) The thermocouple leads should be embedded in the plate material if possible.

Also, when a thermocouple is employed to measure plate temperatures the thermal error will:

- (6) Increase with decreasing thickness and decreasing thermal conductivity of the plate metal.

(7) Increase with decreasing unit thermal convective conductances over the plate.

(8) Increase with increasing unit thermal convective conductance over the thermocouple leads.

STEADY-STATE HEAT TRANSFER IN PIN-FIN PLATES

The question as to the effect of the plate thermal conductivity on the heat transferred by a pin-fin plate (fig. 6) arises frequently. Ordinarily, for the case of heat transfer through thin metallic plates, the resistance of the plate to heat flow can be safely neglected in calculations, but for pin-fin plates in which there exists a temperature distribution along the surface of the plate due to the finite conductivity of the plate, the plate thermal conductivity (or thickness) can be of importance.

Steady-State Heat-Transfer Equations for Limiting Plate

Thermal Conductivities

Heat flow from the hot fluid at temperature T_1 into the plate can be thought of as following two parallel paths into the plate; one through the pin fins into the plate, and the other from the hot fluid into the nonpinned portion of the plate.

In the plate two limiting conditions of plate thermal conductivity are possible which will affect the heat flow through the pin-fin plate. If the plate thermal conductivity parallel to the surface is postulated to be infinite, the temperature of the pin bases and of the nonpinned section of the plate must be equal because no temperature gradients could exist parallel to the surface. The other limiting condition is encountered when the plate thermal conductivity parallel to the surface is zero. In this case the pin base temperature, t_m in the sketch accompanying equation (32), would be independent of and, in general, different from the temperature, t_n in the same sketch, of the non-pinned section of the plate because no heat would be able to flow from one section of the plate to another. For both limiting cases the heat may be considered to leave the plate by two parallel paths similar to those by which it entered.

The accompanying sketch presents the thermal circuit for a pin-fin plate of infinite thermal conductivity in the direction parallel to the surface. The equation giving the heat rate through this plate (equation (31)) can be obtained in the same manner as the equation for the current in an analogous electrical circuit can be obtained.

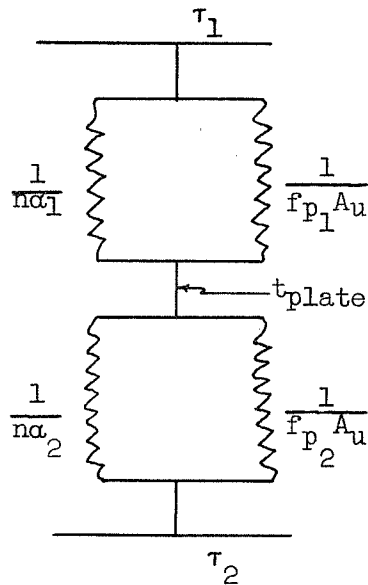

$$q = \left(\frac{1}{\frac{1}{n\alpha_1 + f_{p1}A_u} + \frac{1}{n\alpha_2 + f_{p2}A_u}} \right) (\tau_1 - \tau_2) \quad (31)$$

Similarly the following sketch gives the thermal circuit for zero-plate thermal conductivity parallel to the plate surface, and equation (32) gives the heat rate for this condition.

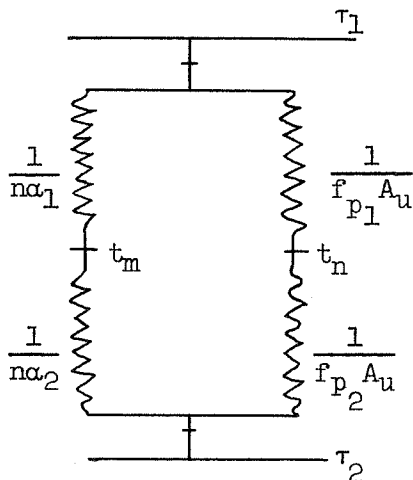

$$q = \left(\frac{1}{\frac{1}{f_{p1}A_u} + \frac{1}{f_{p2}A_u} + \frac{1}{n\alpha_1} + \frac{1}{n\alpha_2}} \right) (\tau_1 - \tau_2) \quad (32)$$

The statement that the thermal conductivity of the plate normal to the plate surface is infinite, whereas that parallel to the surface is zero, finite, or infinite, is a type of idealization that is often necessary in obtaining mathematical solutions. Postulation of infinite

thermal conductivity normal to the surface is an acceptable idealization because the thermal convective resistances on either side of the plate are large compared with the thermal resistance of the plate in the direction normal to its surface. It will be seen later that the case of infinite plate thermal conductivity usually approximates the heat rate through a pin-fin plate closely enough to permit use of equation (31), whereas the case of zero thermal conductivity parallel to the surface is an idealization which is never applicable to metallic plates.

It is clear that calculation of the heat-transfer rates by equations (31) and (32) will yield two limiting values of heat rate between which the heat rate for a plate with finite conductivity must fall.

Finite Thermal Conductivity of Plate

In order to determine the effect of finite-plate thermal conductivity or thickness on heat-transfer rates, an analysis of the heat flow through a pin-fin plate with infinite thermal conductivity in the direction normal to its surface but with a finite value in the direction parallel to the plate surface will be made.

The analysis can be made in the following manner: Heat flow into the pin base,

$$q_{pin} = \alpha_1 (\tau_1 - t_b) \quad (33)$$

Heat flow into the unpinned plate,

$$q_{plate} = f_{p_1} A_u (\tau_1 - t_\infty) \quad (34)$$

Heat flow into the plate with n pins,

$$q = f_{p_1} A_u (\tau_1 - t_\infty) + n\alpha_1 (\tau_1 - t_b) - q_n \quad (35)$$

where q_n is the decrease in heat flow from the hot fluid to the exposed surface of the plate due to its rise in temperature attributable to the presence of the pins.

The equations defining heat flow and temperature distribution in the plate are linear homogeneous differential equations so the temperature fields and the heat transfer due to each fin are additive. Thus the heat-transfer decrease (q_n from equation (35)) is the sum of the effects of the individual pins.

The effect of a single pin is

$$q_{\text{decrease}} = \int_{r_s}^{\infty} 2\pi r f_{p1} (t - t_{\infty}) dr \quad (36)$$

but

$$t - t_{\infty} = C_2 K_0 (\sqrt{\beta} r)$$

therefore

$$q_{\text{decrease}} = 2\pi f_{p1} C_2 \frac{r_s K_1 (\sqrt{\beta} r_s)}{\sqrt{\beta}} \quad (37)$$

The effect of n pins is

$$q_n = \frac{2n\pi r_s f_{p1} C_2 K_1 (\sqrt{\beta} r_s)}{\sqrt{\beta}} \quad (38)$$

Thus the heat transferred by the pin-fin plate is

$$q = f_{p1} A_u (\tau_1 - t_{\infty}) + n\alpha_1 (\tau_1 - t_b) - \frac{2n\pi r_s f_{p1} C_2 K_1 (\sqrt{\beta} r_s)}{\sqrt{\beta}} \quad (39)$$

The term C_2 can be determined, as before, by making a heat balance on the pin-fin base. When one pin in the plate is considered, the following can be written:

Heat transferred into the pin base by the pin,

$$q_1 = \alpha_1 (\tau_1 - t_b) \quad (40)$$

Heat transferred from the pin base by the opposite pin (or, for an unpinned surface, the heat transferred by the flat plate directly under the pin base),

$$q_2 = \alpha_2 (t_b - \tau_2) \quad (41)$$

Heat transferred from the pin base into the surrounding plate,

$$q_{\text{plate}} = -kA \left(\frac{dt}{dr} \right)_{r=r_s} = -k2\pi r_s b \frac{d}{dr} \left[C_2 K_0(\sqrt{\beta} r) \right]_{r=r_s} \quad (42)$$

or

$$q_{\text{plate}} = 2\pi r_s b k C_2 \sqrt{\beta} K_1(\sqrt{\beta} r_s) \quad (43)$$

When a heat balance is made the following equation is obtained:

$$C_2 = \frac{\alpha_1(\tau_1 - t_b) + \alpha_2(\tau_2 - t_b)}{2\pi r_s b k \sqrt{\beta} K_1(\sqrt{\beta} r_s)} \quad (44)$$

When C_2 is substituted into equation (39), there is obtained

$$q_T = f_{p_1} A_u (\tau_1 - t_\infty) + n \alpha_1 (\tau_1 - t_b) - \frac{n f_{p_1} \left[\alpha_1 (\tau_1 - t_b) + \alpha_2 (\tau_2 - t_b) \right]}{f_{p_1} + f_{p_2}} \quad (45)$$

Determination of the pin base temperature t_b will allow calculation of q_T . The temperature of the base of a pin fin can be considered as the sum of the temperature that the base would have with no pins on the plate t_∞ plus the temperature increase due to the pin covering the base and the effects of all other pins.

For in-line equidistant pins (shown in the following sketch) utilization of the fact that the four quadrants surrounding any one fin are symmetrical gives

$$\begin{aligned}
 t_b = t_\infty + C_2 K_0(\sqrt{\beta} r_s) + 4C_2 \left\{ K_0(a\sqrt{\beta}) + K_0(2a\sqrt{\beta}) + K_0(3a\sqrt{\beta}) \right. \\
 + K_0(4a\sqrt{\beta}) + \dots + K_0(\sqrt{2\beta}a) + K_0(2\sqrt{2\beta}a) + K_0(3\sqrt{2\beta}a) + \dots \\
 + 2 \left[K_0(\sqrt{5\beta}a) + K_0(2\sqrt{5\beta}a) + \dots + K_0(\sqrt{10\beta}a) + \dots + K_0(\sqrt{13\beta}a) \right. \\
 \left. \left. + K_0(\sqrt{17\beta}a) + \dots \right] \right\} \quad (46)
 \end{aligned}$$

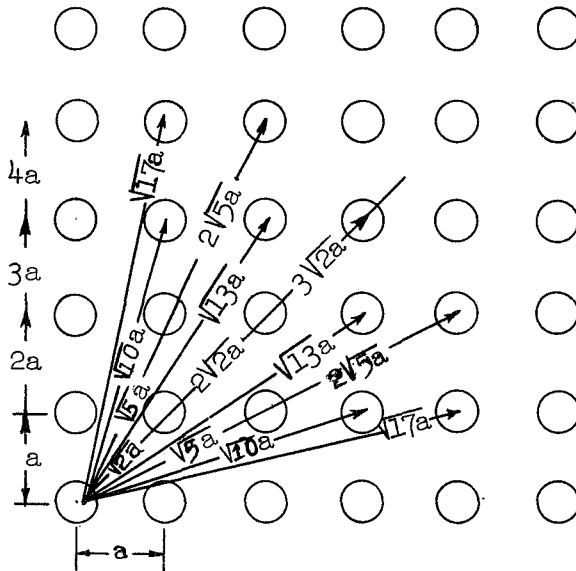

Pin-fin spacing.

The terms in the series represent the temperature increase of the pin base due to the temperature increments of all other pins. This series is for equidistant in-line pins but other series for any symmetrical pin arrangements can easily be obtained. It should be noted that the number of pins in an actual pin-fin plate has no bearing on the number of terms in the series but that the series should, in any case, be calculated for an infinite number of pins (see the following discussion). Fortunately the series converges rapidly and the number of terms given in equation (46) will be sufficient for most applications.

Inserting the value of C_2 , which contains the base temperature t_b , and rearranging results in

$$\begin{aligned}
 \frac{(t_b - t_\infty) \left[2\pi r_s b k \sqrt{\beta} K(\sqrt{\beta} r_s) \right]}{\alpha_1 \tau_1 + \alpha_2 \tau_2 - t_b(\alpha_1 + \alpha_2)} = K_0(\sqrt{\beta} r_s) + 4 \left[K_0(a\sqrt{\beta}) + K_0(2a\sqrt{\beta}) \right. \\
 \left. + K_0(3a\sqrt{\beta}) + K_0(4a\sqrt{\beta}) + \dots + K_0(\sqrt{2\beta}a) + \dots \right] \quad (47)
 \end{aligned}$$

which may be solved for t_b . Substitution of t_b in equation (45) then gives the heat rate for a pin-fin plate with a finite value of plate conductivity.

Discussion

When conditions exist in a pin-fin plate which promote heat flow in the plate radially to or from the pin bases, the decrease in heat transferred due to the finite thermal conductivity of the plate metal may be appreciable. Figure 7 shows the effect of plate thermal conductivity k_p for a pin-fin plate chosen to magnify the effect.

From this figure it can be seen that if the pin-fin plate were made of Inconel ($k_p = 7 \text{ Btu}/(\text{hr})(\text{sq ft})(^\circ\text{F}/\text{ft})$) 0.025-inch thick, the heat transferred would be about 20 percent less than that for a pin-fin plate of infinite conductivity, whereas a pin-fin plate of copper 0.025-inch thick would transfer about 2 percent less than the plate of infinite conductivity.

It can be seen from equations (13) and (18) that the thermal conductivity of the plate always appears in the product (bk_p) . For this reason whatever is stated concerning the effect of change of thermal conductivity on the heat flow through pin-fin plates also applies to the effect of change of plate thickness.

The mathematical analysis of the pin-fin plate has been written for a finite area and number of pins even though at one point it was necessary to consider the plate as infinite in extent. The justification for this procedure can be found in the following reasoning.

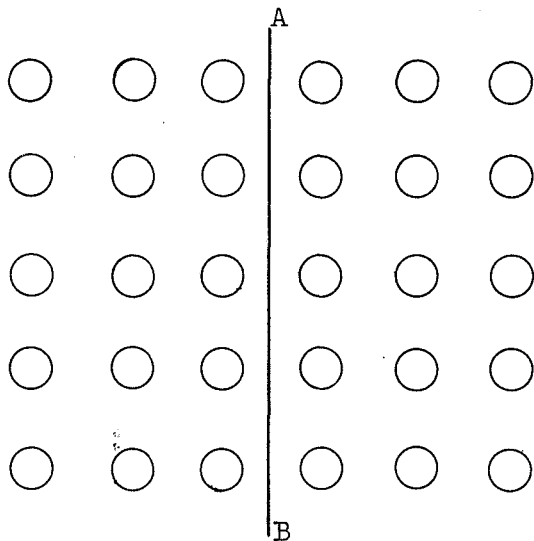

If one imagines the accompanying figure to be a section of an infinite pin-fin plate, it can be stated that no heat flows in the plate across the midline AB because the tendency for flow in the two directions is equal. This is equivalent to stating that the plate is cut at this line and the cut edges are perfectly insulated. The temperature distribution and the heat flow in both sections would be unaltered by the change. Similar reasoning for other lines will produce an isolated section (with insulated edges) of the infinite pin-fin plate in which the temperature and heat transfer are unchanged from that of a plate of infinite extent.

Remarks

The following remarks apply to the second application of the equation for steady-state temperature distribution:

1. In most cases it is possible to calculate the heat-transfer rate of pin-fin plates by assuming the plate thermal conductivity to be infinite.
2. Thin pin-fin plates of low thermal conductivity should be analyzed by the method presented if it is to be established that they do not appreciably decrease the heat-transfer rate below that which could be obtained by a plate of infinite conductivity.

DETERMINATION OF STEADY-STATE CORRECTION FACTORS FOR HEAT METERS

The heat meter (references 1 and 2) allows the determination of heat flow through the meter by measurement of the temperature drop through the thermal resistance of the meter. Although the thermal resistance of the meter is made as small as possible, it nevertheless adds resistance to the thermal circuit to which it is applied, thus altering the heat rate that this thermal circuit would have in the absence of the meter. For this reason it is necessary to apply a correction factor to the heat rate through the meter to obtain the heat rate the thermal circuit would have in the absence of the meter. This correction factor is defined as the ratio of the heat rate through the plate in the absence of the meter to the actual heat rate through the meter (that is, measured by the meter). When the notation given in the following figure is used, the correction factor is q_0/q_m .

Methods of correction have been presented in references 1 and 2. These corrections, however, have postulated that the heat flows only in the direction normal to the plate and meter surfaces (that is, that there exists no heat flow "around" the meter). This postulate is closely realized in the meter but, due to the high thermal conductivity

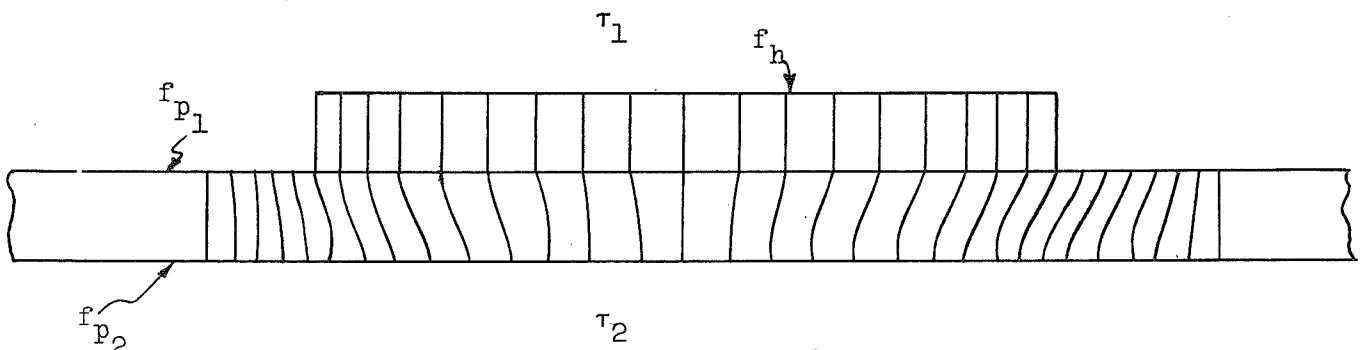

Heat-flow lines in a heat meter. Heat meter shown with zero thermal conductivity parallel to surface so that heat-flow lines are parallel therein.

of metals, is in error when applied to the metal plate covered by the heat meter. If, for example, the meter is on the hot side of the plate, more heat will flow into the plate than into the meter due to its insulating effect. Part of the heat which flowed into the exposed plate will then flow in the plate parallel to its surface into the section under the meter because of the lower temperature of this section produced by the insulating property of the meter. Conversely, if the meter is on the cold side of the plate, heat will flow from the section under the meter into the surrounding plate. It is clear then that a correction to the measurement of heat rate by the meter which will include the effect produced by the heat that flows through the surface and then around the meter is desirable.

In order to obtain a solution it will be necessary to define the system by the following postulates.

- (1) The heat meter is circular.
- (2) The thermal conductivity of the heat meter is zero in the direction parallel to its surface.
- (3) Thermal conductivity of the metal plate is infinite in the direction normal to its surface.
- (4) Fluid temperatures and unit thermal conductances are uniform over the plate and meter surfaces. (Unit thermal conductances over the plate and meter may differ.)

Two solutions for the correction factor for the meter will be obtained. The first solution will require an additional postulate that the thermal conductivity of the plate metal under the meter is infinite (that is, there are no temperature gradients in the plate under the meter). The second solution, which will be more difficult to use but will approach the actual system more closely, will be based only on postulates (1) to (4), or, in other words, the temperature distribution under the meter will be considered a variable in the second solution.

The analyses will consider the heat meter to be placed on the side of the plate for which the variables are denoted by the subscript 1.

First Solution

The heat that flows through a flat plate subjected to fluids of different temperature on either side is

$$q_0 = f_{p_1} A_m (\tau_1 - t_\infty) \quad (48)$$

If a heat meter is now attached to the plate, the heat that flows through the meter is given by equation (14)

$$q_m = \alpha_1 (\tau_1 - t_s) \quad (49)$$

where t_s is the temperature of the portion of the metal directly underneath the meter (which is considered uniform for this first solution (see following figure)). Also

$$\frac{1}{\alpha_1} = \frac{1}{F_h A_m} + \frac{\delta}{k_m A_m} + R_c \quad (50)$$

When

$$(\tau_1 - t_s) = (\tau_1 - t_\infty) + (t_\infty - t_s)$$

and it is observed that the system is the same as the one for which the general solution (equation (13)) was obtained, the temperature distribution in the metal surrounding the meter can be represented by

$$t_\infty - t = -C_2 K_0(\sqrt{\beta} r)$$

and at $r = r_s$,

$$t_\infty - t_s = -C_2 K_0(\sqrt{\beta} r_s)$$

The value of C_2 is determined by means of a heat balance on the portion of the plate directly under the meter which has been previously obtained in the derivation of equation (18). The values of α_1 and α_2 are given in table I under system 3.

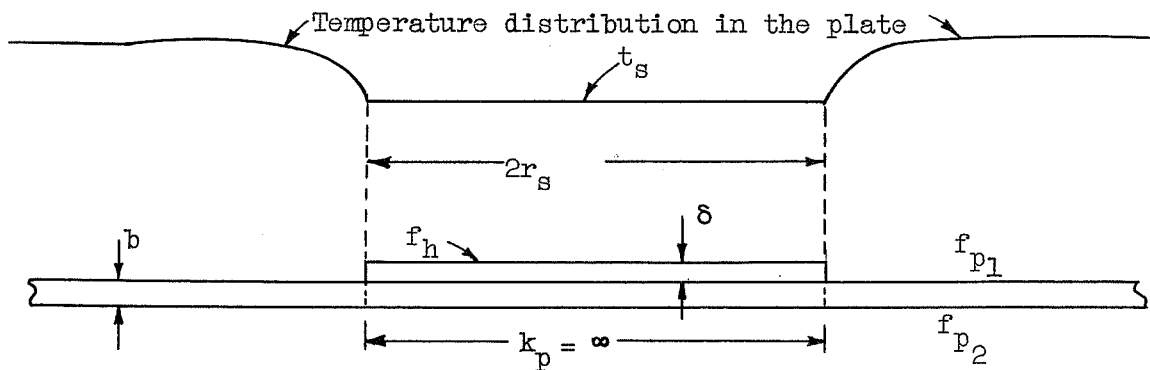

Thus the value of q_m is

$$q_m = \alpha_1 (\tau_1 - t_\infty) - \alpha_1 c_2 K_0 (\sqrt{\beta} r_s) \quad (51)$$

When the heat rate through the plate when the meter is absent (q_0 from equation (48)) is divided by the heat rate through the meter (q_m from equation (51)) the correction factor by which the heat-transfer rate indicated by the heat meter must be multiplied is

$$\frac{q_0}{q_m} = \frac{f_{p1} A_m (\tau_1 - t_\infty)}{\alpha_1 (\tau_1 - t_\infty) - \frac{\alpha_1 [\alpha_1 (\tau_1 - t_\infty) + \alpha_2 (\tau_2 - t_\infty)] K_0 (\sqrt{\beta} r_s)}{K_0 (\sqrt{\beta} r_s) (\alpha_1 + \alpha_2) + 2\pi r_s b k \sqrt{\beta} K_1 (\sqrt{\beta} r_s)}} \quad (52)$$

recalling that

$$\frac{\tau_2 - t_\infty}{\tau_1 - t_\infty} = - \frac{f_{p1}}{f_{p2}}$$

This equation can be rewritten as

$$\frac{q_0}{q_m} = \frac{f_{p1} A_m}{\alpha_1 \left(\alpha_1 - \alpha_2 \frac{f_{p1}}{f_{p2}} \right) - \frac{\alpha_1 (\alpha_1 + \alpha_2) K_0 (\sqrt{\beta} r_s)}{\alpha_1 + \alpha_2 + 2\pi r_s b k \sqrt{\beta} \frac{K_1 (\sqrt{\beta} r_s)}{K_0 (\sqrt{\beta} r_s)}}} \quad (53)$$

or as

$$\frac{q_0}{q_m} = \frac{\left(\frac{1 + \lambda}{\alpha_1} + \frac{1}{\alpha_2} \right)}{\left(\frac{1 + \lambda}{f_{p1} A_m} + \frac{1}{f_{p2} A_m} \right)} \quad (54)$$

where $\lambda = \frac{2\pi r_s b k \sqrt{\beta} K_1(\sqrt{\beta} r_s)}{\alpha_2 K_0(\sqrt{\beta} r_s)}$ and the terms $\frac{1}{\alpha}$ and $\frac{1}{f_p A_m}$ are the thermal resistances in specific portions of the thermal circuit.

Because most heat meters are square, it is necessary to determine some equivalent source radius r_s . This radius can be calculated by setting the meter area equal to the area of an equivalent circle and defining r_s as (see accompanying sketch)

$$r_s = \sqrt{\frac{A_m}{\pi}} \quad (55)$$

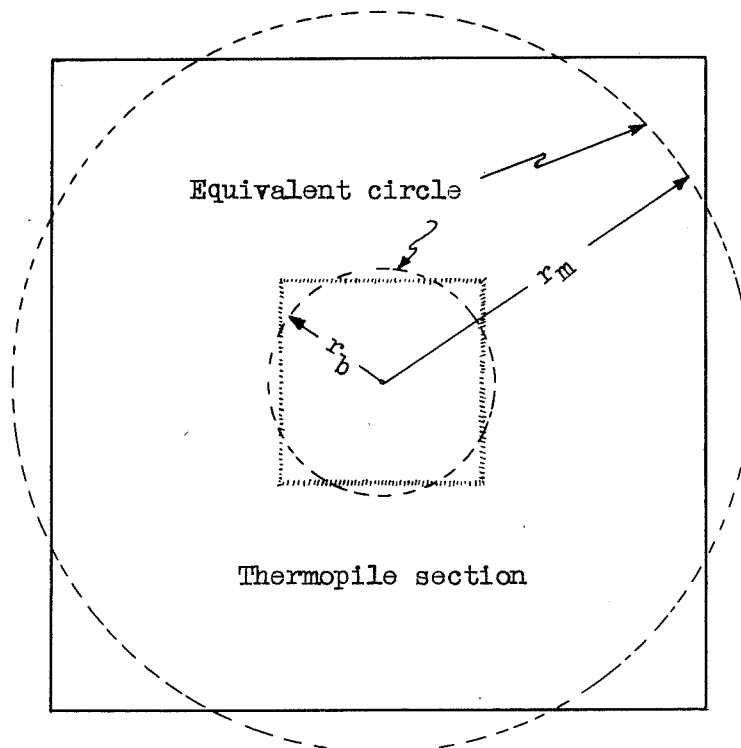

Equation (54) can be used to show the effects of the two limiting values of the plate thermal conductivity parallel to the surface (that is, $k = 0$ and $k = \infty$).

For the use of zero thermal conductivity parallel to the plate surface, the value of λ is zero, and equation (54) reduces to

$$\frac{q_0}{q_m} = \frac{\frac{1}{\alpha_1} + \frac{1}{\alpha_2}}{\frac{1}{f_{p1} A_m} + \frac{1}{f_{p2} A_m}} = \frac{\frac{1}{f_n} + \frac{\delta}{k_m} + A_m R_c + \frac{1}{f_{p2}}}{\frac{1}{f_{p1}} + \frac{1}{f_{p2}}} \quad (56)$$

Thus, for this case the correction factor is the ratio of the thermal resistance $\left(\frac{1}{\alpha_1} + \frac{1}{\alpha_2}\right)$, which the heat overcomes when flowing from the hot fluid through the meter and plate to the cold fluid, to that resistance $\left(\frac{1}{f_{p1} A_m} + \frac{1}{f_{p2} A_m}\right)$ which the heat overcomes when flowing from the hot fluid through the plate to the cold fluid without the meter in place.

This result is the same as that given by equation (10) of reference 1 in which case the flow around the meter was postulated to be zero (that is, k in the direction parallel to the surface is zero). A slight difference, however, exists between equation (56) and equation (10) of reference 1 in that the thermal resistance of the plate perpendicular to the surface is not included in equation (56). The difference introduced by this omission is negligible for metallic plates but equation (56) can be made to include this resistance by defining a new term f_{p2}' which can be calculated from

$$\frac{1}{f_{p2}'} = \frac{1}{f_{p2}} + \frac{b}{k} \quad (57)$$

and can be used in the equations in place of f_{p2} .

If the other limiting value of the plate thermal conductivity parallel to the surface, k equals infinity, is used, then equation (54) becomes

$$\frac{q_0}{q_m} = \frac{\frac{\lambda}{\alpha_1}}{\frac{\lambda}{f_{p1} A_m}} = \frac{\frac{1}{\alpha_1}}{\frac{1}{f_{p1} A_m}}$$

$$= \frac{\frac{1}{f_n} + \frac{\delta}{k_m} + R_c A_m}{\frac{1}{f_{p1}}} \tag{58}$$

The correction factor for this case can be interpreted as the ratio of the resistance to heat flow $\frac{1}{\alpha_1}$, from the hot fluid through the meter and then into the plate, to the thermal resistance $\frac{1}{f_{p1} A_m}$ from the hot fluid directly into the plate without the meter in place.

Table II presents values of q_0/q_m obtained from equations (54), (56), and (58) for zero, finite, and infinite thermal conductivity of the plate to which the heat meter is attached.

Second Solution

A solution more closely approximating the actual heat flow conditions can be obtained by including the temperature distribution parallel to the surface in the metal under the meter. Thus if the thermal conductivity of the plate is postulated finite in the direction parallel to the plate surface, the following equations which give the temperature distribution for the plate can be written.

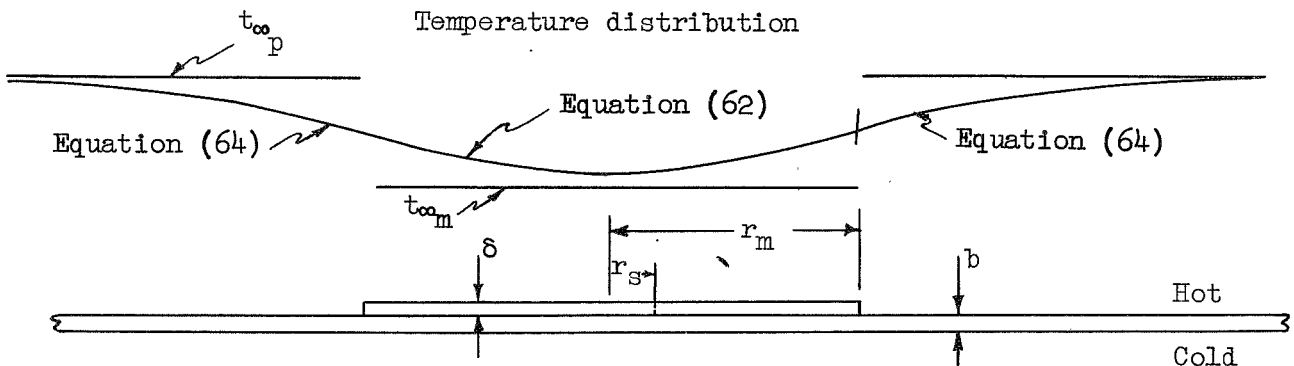

The temperature distribution in the plate under the meter is given by the following equation (see equation (11)) when $0 < r < r_m$

$$t - t_{\infty m} = C_1 I_0(\sqrt{\beta_m r}) + C_2 K_0(\sqrt{\beta_m r}) \quad (59)$$

and, similarly, for the temperature distribution in the plate not covered by the meter when $r_m < r < \infty$

$$t - t_{\infty p} = C_1' I_0(\sqrt{\beta_p r}) + C_2' K_0(\sqrt{\beta_p r}) \quad (60)$$

where

$$\beta_m = \frac{f_m + f_{p_2}}{bk_p}, \frac{1}{(\text{sq ft})}$$

$$\beta_p = \frac{f_{p_1} + f_{p_2}}{bk_p}, \frac{1}{(\text{sq ft})}$$

$$\frac{1}{f_n} = \frac{1}{f_{p_2}} + \frac{\delta}{k_m} + R_c A, \frac{1}{\text{Btu}/(\text{hr})(\text{sq ft})(^{\circ}\text{F})}$$

A area over which contact resistance R_c applies, square feet

δ heat meter thickness, feet

$t_{\infty m}$ temperature which section of plate under meter would attain if thermal conductivity of plate parallel to plate surface were zero, or, the equivalent, temperature which plate would attain if meter were infinite in extent. Defined as

$$t_{\infty m} = \frac{f_m \tau_1 + f_{p_2} \tau_2}{f_m + f_{p_2}}, \text{ } ^{\circ}\text{F}$$

$t_{\infty p}$ temperature which plate would attain if heat meter were absent;

$$t_{\infty p} = \frac{f_{p_1} \tau_1 + f_{p_2} \tau_2}{f_{p_1} + f_{p_2}}, \text{ } ^{\circ}\text{F}$$

At $r = 0$ it is necessary that the heat flow parallel to the plate surface be zero, that is:

$$-kA \left(\frac{dt}{dr} \right)_{r=0} = 0$$

or

$$\left(\frac{dt}{dr} \right)_{r=0} = 0$$

Differentiating equation (59),

$$\frac{dt}{dr} = \sqrt{\beta_m} C_1 I_1(\sqrt{\beta_m r}) - C_2 \sqrt{\beta_m} K_1(\sqrt{\beta_m r}) \quad (61)$$

for $r = 0$, $\frac{dt}{dr} = 0$, and $I_1(\sqrt{\beta_m r}) = 0$, but $K_1(\sqrt{\beta_m r}) = \infty$; therefore C_2 must be zero. Thus equation (59) becomes

$$t - t_{\infty m} = C_1 I_0(\sqrt{\beta_m r}) \quad (62)$$

At $r = \infty$ it is necessary that t , the temperature of the plate, be equal to $t_{\infty p}$; consequently, $(t - t_{\infty p}) = 0$ at $r = \infty$. Thus at $r = \infty$ equation (60) gives

$$t - t_{\infty p} = C_1 I_0(\sqrt{\beta_p r}) + C_2 K_0(\sqrt{\beta_p r}) = 0 \quad (63)$$

At $r = \infty$, $I_0(\sqrt{\beta_p r}) = \infty$; therefore the constant C_1 must be zero. As a result, equation (60) becomes

$$t - t_{\infty p} = C_2 K_0(\sqrt{\beta_p r}) \quad (64)$$

Two remaining boundary conditions can be stated. First, the temperatures given by equations (62) and (64) must be equal at $r = r_m$.

$$C_1 I_0(\sqrt{\beta_m} r_m) + t_{\infty_m} = C_2 K_0(\sqrt{\beta_p} r_m) + t_{\infty_p} \quad (65)$$

Secondly, at $r = r_m$ equations (62) and (64) must give the same heat flow parallel to the plate surface or, stated mathematically, the derivatives of the equations with respect to length r must be equal. Thus at $r = r_m$

$$C_1 \sqrt{\beta_m} I_1(\sqrt{\beta_m} r_m) = -C_2 \sqrt{\beta_p} K_1(\sqrt{\beta_p} r_m) \quad (66)$$

The heat that flows through the thermopile section (radius r_s) of the heat meter is

$$q_m = \int_0^{r_s} 2\pi r f_m (t - \tau_1) dr \quad (67)$$

writing

$$t - \tau_1 = (t - t_{\infty_m}) + (t_{\infty_m} - \tau_1) \quad (68)$$

equation (67) becomes

$$\begin{aligned} q_m &= \pi r_s^2 f_m (t_{\infty_m} - \tau_1) + 2\pi f_m C_1 \int_0^{r_s} r I_0(\sqrt{\beta_m} r) dr \\ &= \pi r_s^2 f_m (t_{\infty_m} - \tau_1) + \frac{2\pi f_m C_1 r_s I_1(\sqrt{\beta_m} r_s)}{\sqrt{\beta_m}} \end{aligned} \quad (69)$$

Solving equations (65) and (66) for the constant C_1 and inserting its value in equation (69), there results for q_m the equation

$$q_m = \pi r_s^2 f_m (t_{\infty m} - \tau_1) + \frac{2\pi f_m r_s I_1 (\sqrt{\beta_m r_s})}{\sqrt{\beta_m}} \left[\frac{t_{\infty p} - t_{\infty m}}{I_0 (\sqrt{\beta_m r_m}) + \frac{\sqrt{\beta_m} I_1 (\sqrt{\beta_m r_m}) K_0 (\sqrt{\beta_p r_m})}{\sqrt{\beta_p} K_1 (\sqrt{\beta_p r_m})}} \right] \quad (70)$$

In the absence of the meter, the heat q_0 that would flow through the same area πr_s^2 (area of plate covered by thermopile section of heat meter) is

$$q_0 = \pi r_s^2 f_{p1} (t_{\infty p} - \tau_1) \quad (71)$$

The correction ratio is thus

$$\frac{q_0}{q_m} = \frac{\pi r_s^2 f_{p1} (t_{\infty p} - \tau_1)}{\pi r_s^2 f_m (t_{\infty m} - \tau_1) + \frac{2\pi f_m r_s I_1 (\sqrt{\beta_m r_s})}{\sqrt{\beta_m}} \left[\frac{t_{\infty p} - t_{\infty m}}{I_0 (\sqrt{\beta_m r_m}) + \frac{\sqrt{\beta_m} I_1 (\sqrt{\beta_m r_m}) K_0 (\sqrt{\beta_p r_m})}{\sqrt{\beta_p} K_1 (\sqrt{\beta_p r_m})}} \right]} \quad (72)$$

Noting that

$$\frac{t_{\infty m} - \tau_1}{t_{\infty p} - \tau_1} = \frac{f_{p1} + f_{p2}}{f_m + f_{p2}} = \frac{\beta_p}{\beta_m}$$

equation (72) can be simplified to

$$\frac{q_0}{q_m} = \frac{f_{p1}/f_m}{\frac{\beta_p}{\beta_m} + \frac{2}{\sqrt{\beta_m} r_s} I_1(\sqrt{\beta_m} r_s) \left[\frac{1 - \frac{\beta_p}{\beta_m}}{I_0(\sqrt{\beta_m} r_m) + \frac{\sqrt{\beta_m} I_1(\sqrt{\beta_m} r_m) K_0(\sqrt{\beta_p} r_m)}{\sqrt{\beta_p} K_1(\sqrt{\beta_p} r_m)}} \right]} \quad (73)$$

Table II presents correction factors calculated by means of equations (53), (56), (58), and (73) for the particular system pictured in the table. The heat-meter correction factors presented in the first three columns are for the case in which the meter is placed on one side of the plate (the side with high f_p), and the remaining three columns present the results for the case when the meter is on the opposite side of the plate (the side with low f_p).

It can be observed from the results presented in table II that the heat-meter correction factors are considerably larger when the meter is placed on the side with the higher f_p (that is, lowest thermal resistance). The importance of the location of the meter is thus apparent. A comparison of the results for the case in which the plate thermal conductivity is 100 reveals that the two methods of solution yield approximately the same value of q_0/q_m . This is especially so when the correction ratio is less than 1.3. Of course the applicability of the heat-meter is questionable when the ratio is larger than 1.3. It should be noted that the example chosen here is one that will magnify the range of correction factors obtained by the various equations and that these factors are larger than those ordinarily encountered.

It will be noticed that the plate thermal conductivity and the plate thickness always appear in the product $k_p b$. Thus if it is said that the correction factor increases with increasing plate conductivity, it may also be said that it increases with the plate thickness in the same proportion.

The second solution (equation (73)) shows that the larger the value of r_m , the smaller will be the correction factor which will approach the value given by equation (56), as a limit, as r_m is increased. This fact has led to the use of guard rings of the same thickness and material around the heat meters.

In actual application the unit thermal conductance may vary along the meter surface because the meter acts as a flat plate in an air stream (see figure on page 15 of reference 2). The guard rings mentioned are useful in minimizing this variation.

Remarks

The following remarks apply to the third application of the equation for steady-state temperature distribution:

1. Two equations ((53) and (73)) have been derived which are useful in the estimation of heat-meter correction factors which include consideration of heat flow around the meter.
2. The use of the second, more exact equation (73) is not warranted except for the case of large correction factors (say, $q_0/q_m > 1.5$).
3. Table II indicates the importance of the location of the heat meter. It is apparent that the meter should be located on the side of the plate with the highest thermal resistance (lowest unit thermal convective conductance).
4. Table II also shows the effect of variation of the thermal conductivity of the plate on this correction factor. For the case in which the thermal resistance of the plate in the direction normal to its surface is small (that is, metallic plates), these results also show the effect of thickness of the plate on which the meter is mounted.
5. Equations (53) and (73) indicate the advisability of placing a guard ring around the meter.

Department of Engineering
University of California
Berkeley, Calif., August 17, 1944

APPENDIX

The notations used for Bessel's functions by various authors differ with the result that there is some confusion in their use. A table of equivalence of symbols for Bessel's functions is given in reference 3 (p. 64). The modified Bessel function of the second kind ν order ($K_\nu(x)$) used in this report is equal to $\frac{1}{2}\pi^{1/2}i^{\nu+1}H_\nu^{(1)}(ix)$ where $H_\nu^{(1)}(ix)$ is the Hankel function given in Jahnke and Emde (reference 6).

The equations presented in this report have been written where possible so that the Bessel functions appear (or can appear) as the ratio $\frac{K_1(x)}{K_0(x)}$. From the foregoing discussion it can be seen that

$$\frac{K_1(x)}{K_0(x)} = \frac{-H_1^{(1)}(ix)}{iH_0^{(1)}(ix)}$$

or in other words it is unnecessary to convert the Hankel functions to Bessel functions when the ratio $\frac{K_1(x)}{K_0(x)}$ is used.

The following approximations (reference 3) will be useful for small values of the argument x .
For $0 < x < 0.05$

$$K_0(x) \cong -\log_e\left(\frac{x}{2}\right) - 0.577$$

and when $0 < x < 0.05$

$$K_1(x) = \frac{1}{x}$$

Figure 8 gives the variation of $\frac{K_1(x)}{K_0(x)}$ as a function of x .

REFERENCES

1. Martinelli, R. C., Morrin, E. H., and Boelter, L. M. K.: An Investigation of Aircraft Heaters. V - Theory and Use of Heat Meters for the Measurement of Rates of Heat Transfer Which Are Independent of Time. NACA ARR, Dec. 1942.
2. Boelter, L. M. K., Poppendiek, H., and Gier, J. T.: An Investigation of Aircraft Heaters. XVII - Experimental Inquiry into Steady State Unidirectional Heat-Meter Corrections. NACA ARR No. 4H09, 1944.
3. Von Kármán, Theodore, and Biot, Maurice A.: Mathematical Methods in Engineering. McGraw-Hill Book Co., Inc., 1940, ch. II.
4. Boelter, L. M. K., Martinelli, R. C., Romie, F. E., and Morrin, E. H.: An Investigation of Aircraft Heaters. XVIII - A Design Manual for Exhaust Gas and Air Heat Exchangers. NACA ARR No. 5A06, 1945.
5. McAdams, William H.: Heat Transmission. Second ed., McGraw-Hill Book Co., Inc., 1942.
6. Jahnke, E., and Emde, F.: Tables of Functions with Formulae and Curves. Dover Publications, 1943, p. 236.

BIBLIOGRAPHY

- Gray, A., Mathews, G. B., and MacRobert, T. M.: Bessel Functions. Macmillan and Co. (London), 1921.
- Sherwood, T. K., and Reed, C. E.: Applied Mathematics in Chemical Engineering. McGraw-Hill Book Co., Inc., 1931, ch. V.
- Boelter, L. M. K., Cherry, V. H., and Johnson, H. A.: Heat Transfer Notes. Third ed., Univ. of Calif. Press (Berkeley), July 1942, ch II.

TABLE I

VALUES OF α_1 , α_2 , AND r_s FOR VARIOUS SYSTEMS

No.	System	α_1	α_2	r_s
1	Single pin fin 	$\sqrt{f_1 P_1 k A_x} \times \tanh \sqrt{\frac{f_1 P_1}{k_1 A_x}} L_1$	$\pi r_s^2 f_1 P_2$	Shown
2	Double pin fin 	$\sqrt{f_1 P_1 k_1 A_x} \times \tanh \sqrt{\frac{f_1 P_1}{k_1 A_x}} L_1$	$\sqrt{f_2 P_2 k_2 A_x} \times \tanh \sqrt{\frac{f_2 P_2}{k_2 A_x}} L_2$	Shown
3	Insulating disk (heat meter) 	$\pi r_s^2 \left(\frac{1}{\frac{1}{f_h} + \frac{\delta}{k_m} + R_c} \right)$	$\pi r_s^2 f_1 P_2$	Shown
4	Bare thermocouple 	$\sqrt{f_1 P_1 k_1 A_{x1}} + \sqrt{f_2 P_2 k_2 A_{x2}}$	$\pi r_s^2 f_1 P_2$	$r_s = \sqrt{r_1^2 + r_2^2}$
5	Insulated thermocouple 	$\sqrt{f_e P_1 k_1 A_{x1}} + \sqrt{f_e P_2 k_2 A_{x2}}$ $\frac{1}{f_e} = \frac{1}{f_1} + \frac{\delta}{k} + R_c A$	$\pi r_s^2 f_1 P_2$	$r_s = \sqrt{r_1^2 + r_2^2}$

TABLE II
COMPARISON OF VALUES OF q_o/q_m

System A				System B		
$b = \frac{1}{16}$ " $f_h = 20$ $\delta = \frac{3}{64}$ " $f_{p1} = 20$ $f_{p2} = 3$ $r_m = 0.212$ ft $r_s = 0.0833$ ft $k_m = 0.1$ Btu/(hr)(sq ft)(°F/ft)				$b = \frac{1}{16}$ " $f_{p1} = 20$ $\delta = \frac{3}{64}$ " $f_h = 3$ $f_{p2} = 3$ $r_m = 0.212$ ft $r_s = 0.0833$ ft $k_m = 0.1$ Btu/(hr)(sq ft)(°F/ft)		
k_p	0	100	∞	0	100	∞
First solution ¹	1.10	1.50	1.78	1.10	1.11	1.12
Second solution ²		1.40			1.11	

¹Values obtained from following equations:

- For zero thermal conductivity, equation (56)
- For finite thermal conductivity, equation (53)
- For infinite thermal conductivity, equation (58)

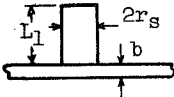
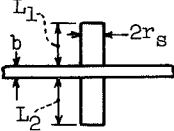
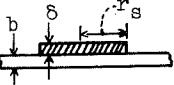
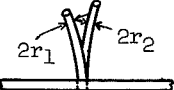
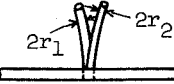
²Values obtained from equation (73).



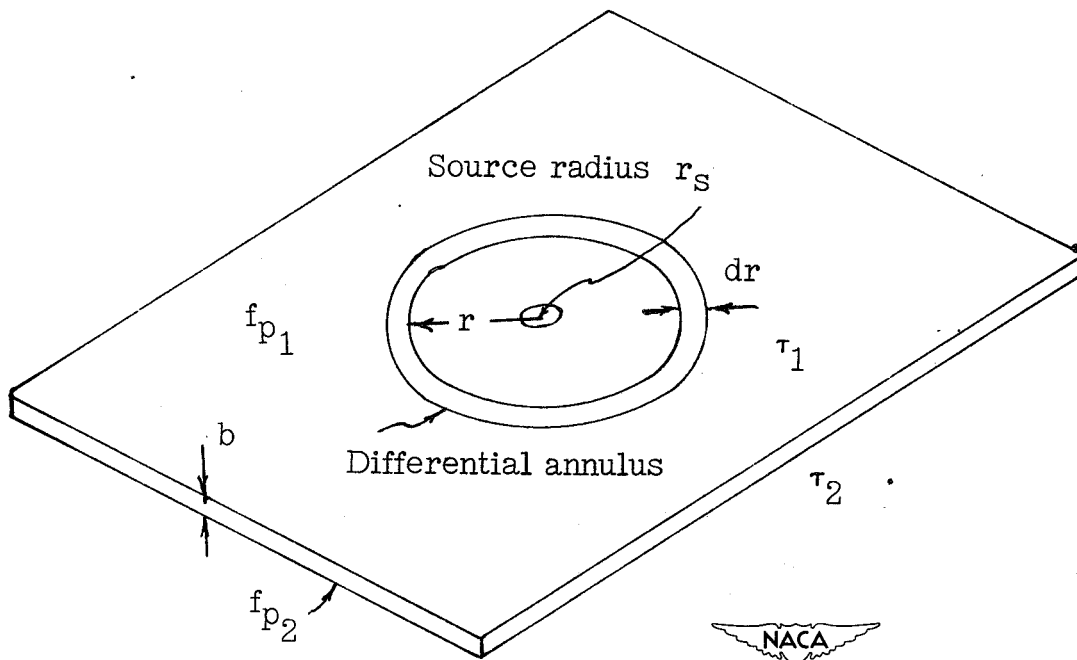

Figure 1.- Source and differential annulus in flat plate.

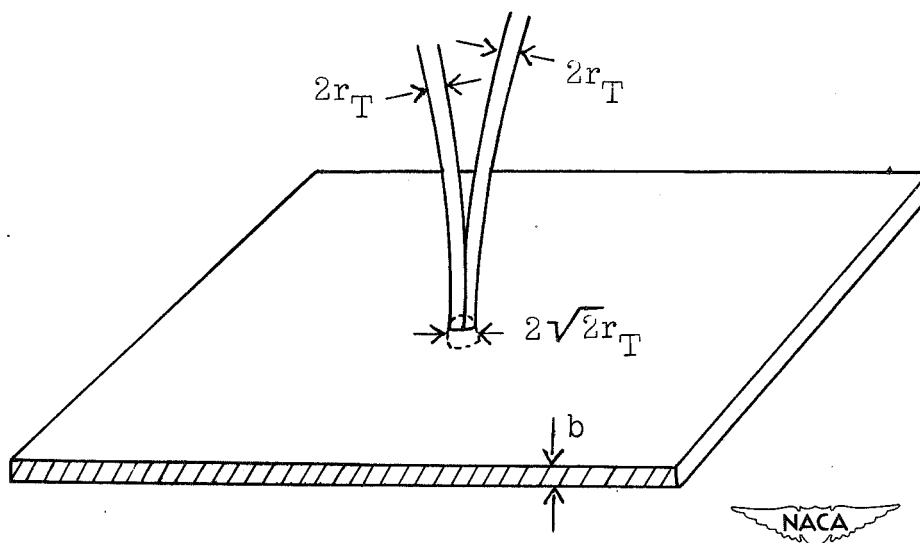
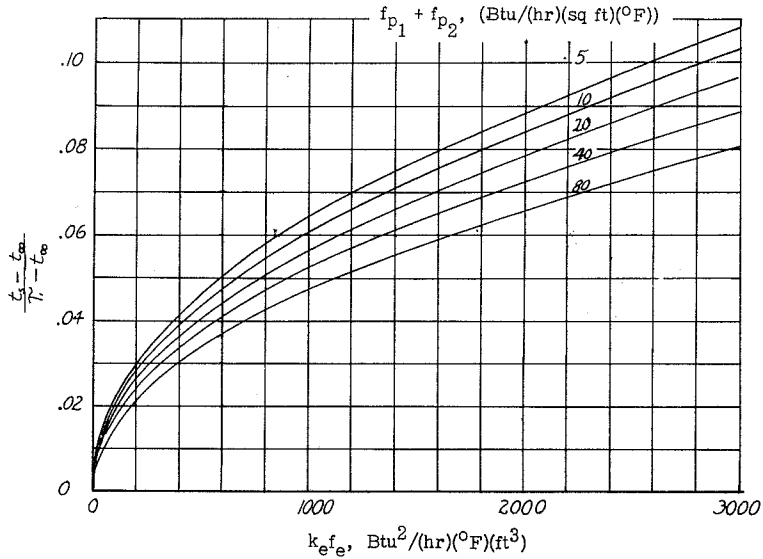
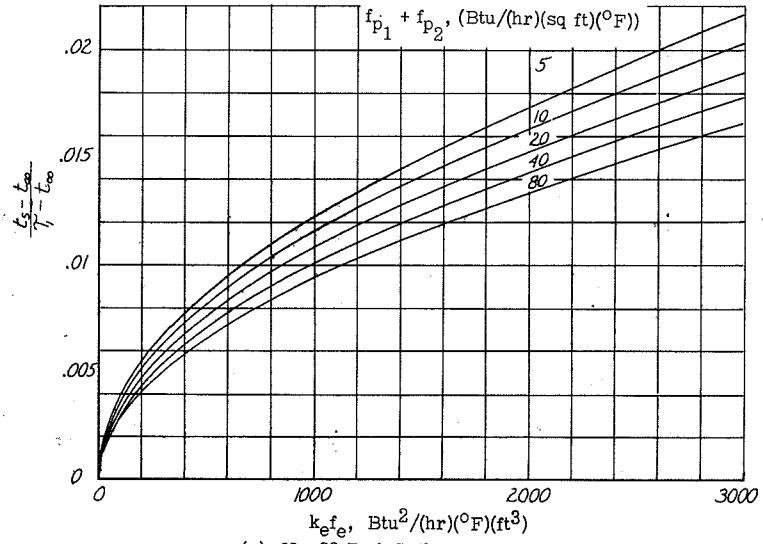

Figure 2.- Installation of thermocouple in section of plate.



(a) No. 28 B. & S. thermocouple leads.



(a) No. 28 B. & S. thermocouple leads.

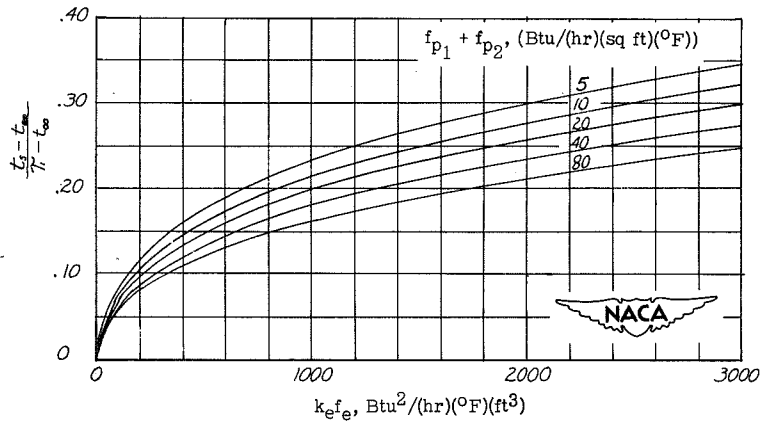

(b) No. 18 B. & S. thermocouple leads.

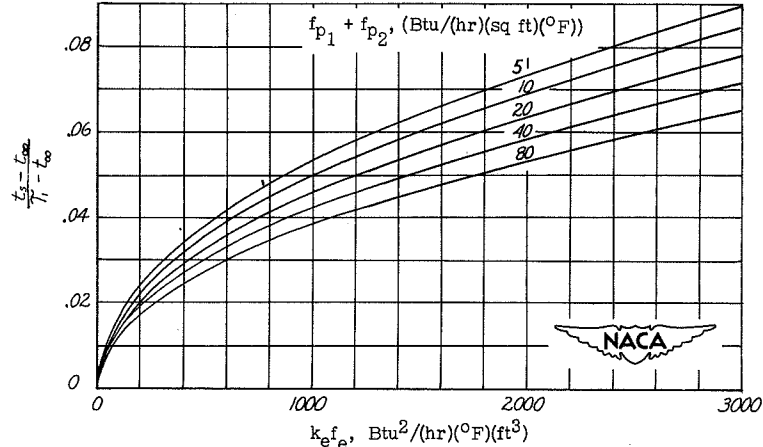

(b) No. 18 B. & S. thermocouple leads.

Figure 3.- Thermocouple error in a flat plate. $bk_p = 0.0375$ Btu per hour per °F ; $\alpha_2 \ll \alpha_1$.

Figure 4.- Thermocouple error in a flat plate. $bk_p = 0.25$ Btu per hour per °F ; $\alpha_2 \ll \alpha_1$.

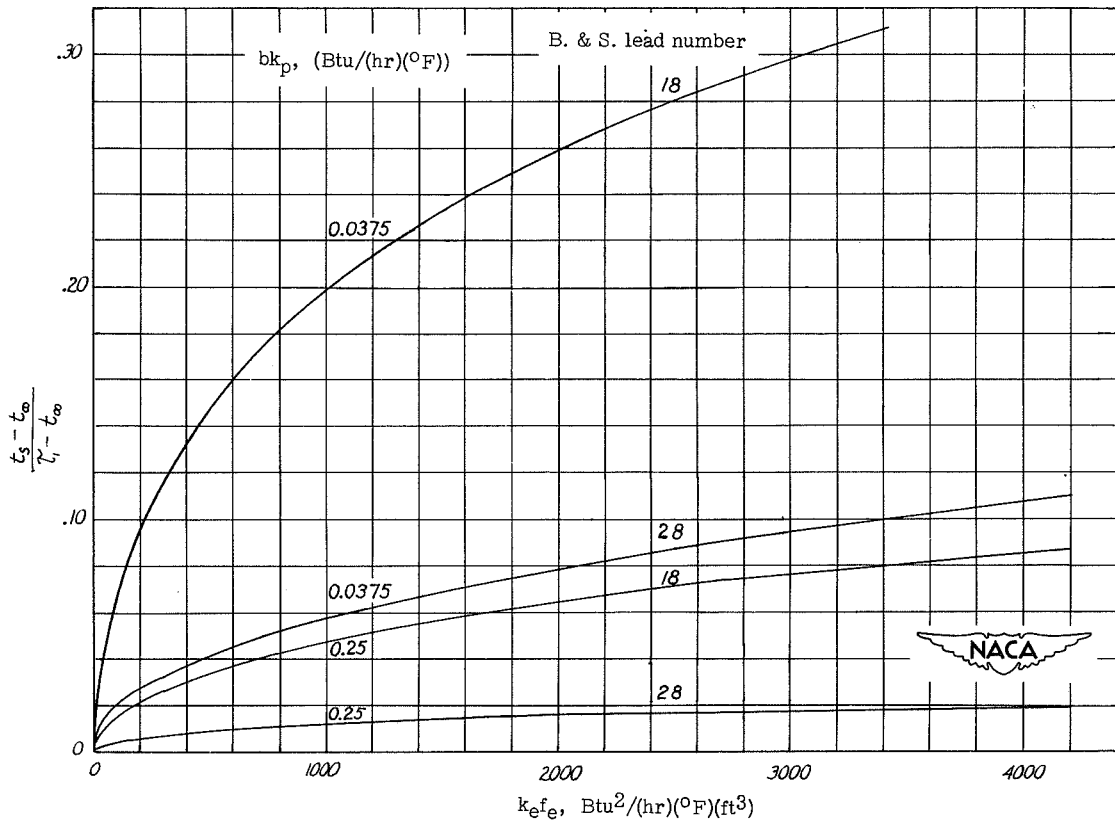

Figure 5.- Summary of thermocouple error for $f_{p1} + f_{p2} = 20 \text{ Btu}/(\text{hr})(\text{sq ft})(^{\circ}\text{F})$.
 $\alpha_2 \ll \alpha_1$.

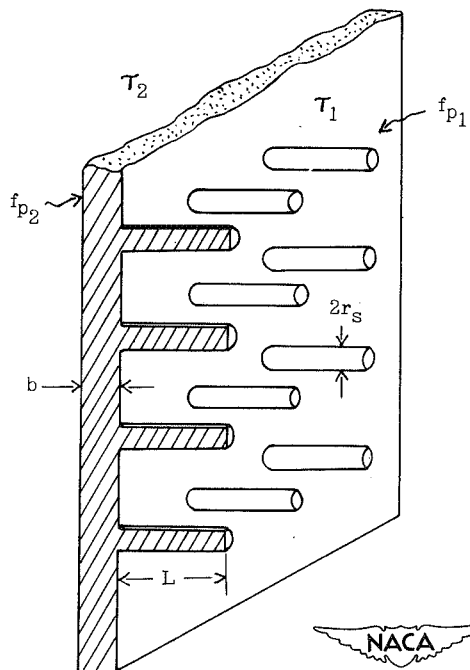

Figure 6.- Section of pin-fin plate. Pins on one side only.

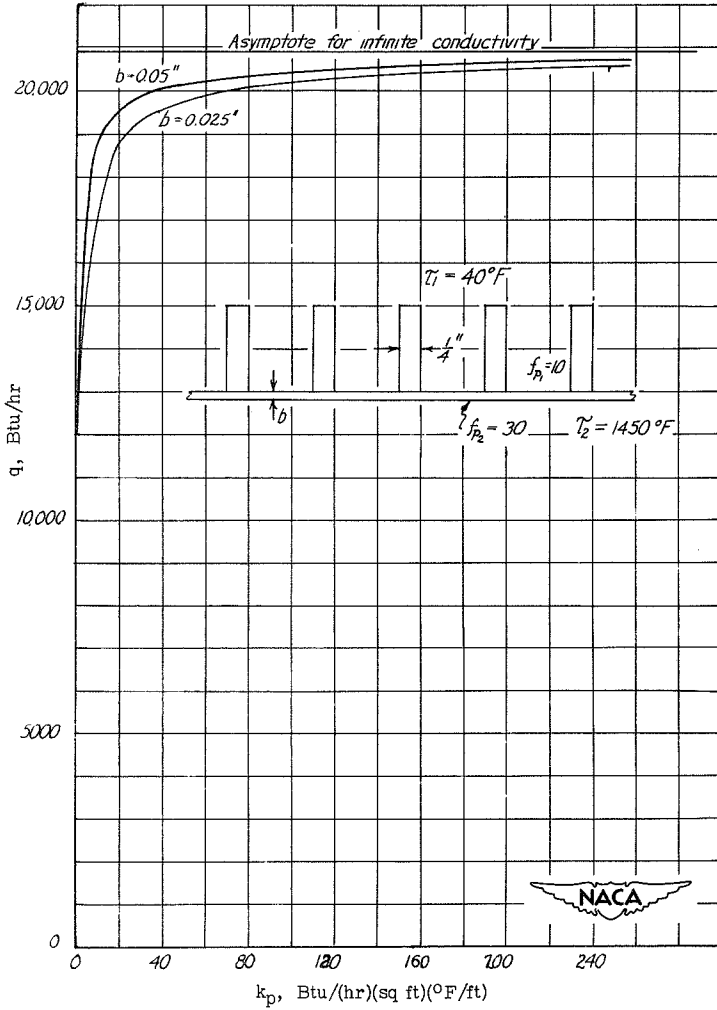

Figure 7.- Variation of heat-transfer rate with thermal conductivity of a pin-fin plate. Number of pins, 144; free unpinned area, 0.951 square feet; pin spacing, 1 inch; $\alpha_1 = 0.14$ Btu per hour per °F.

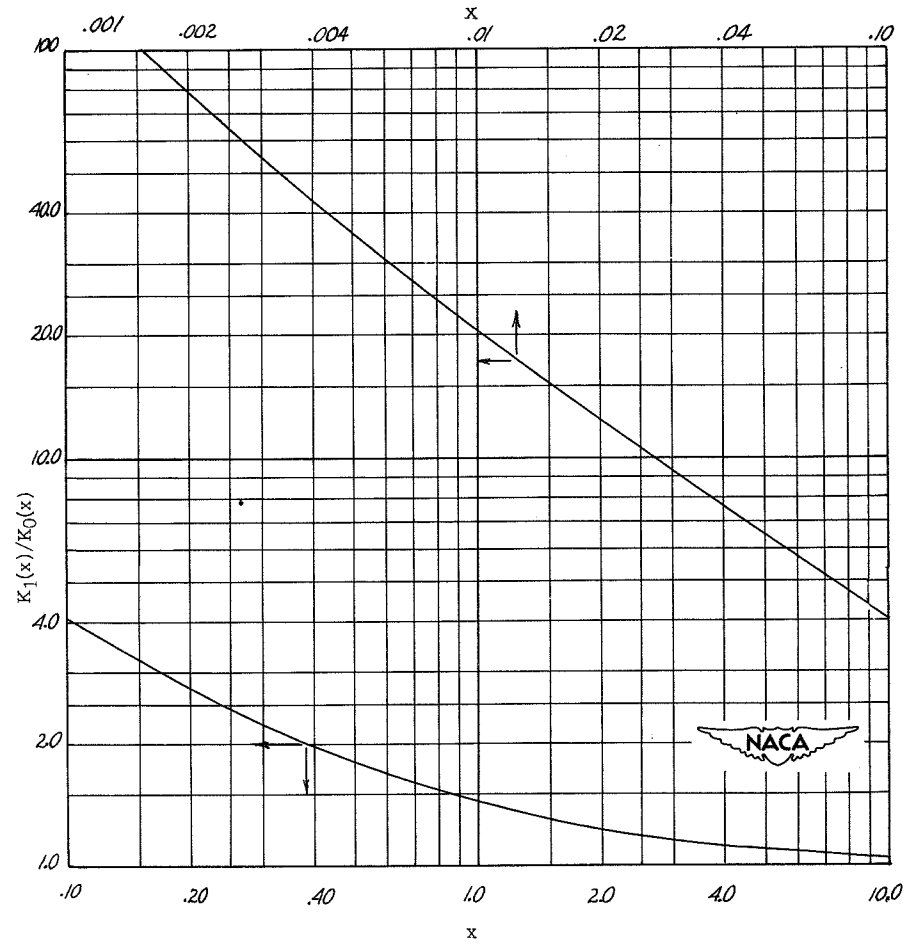

Figure 8.- Plot of ratio $\frac{K_1(x)}{K_0(x)}$ as a function of x .