

3. N21/5:6/2864

GOVT. DOC.

NACA TN 2864

# NATIONAL ADVISORY COMMITTEE FOR AERONAUTICS

TECHNICAL NOTE 2864

Jan 19 '53

BUSINESS AND  
TECHNICAL

CONVECTION OF A PATTERN OF VORTICITY THROUGH A SHOCK WAVE

By H. S. Ribner

Lewis Flight Propulsion Laboratory  
Cleveland, Ohio



Washington  
January 1953

## TABLE OF CONTENTS

	Page
SUMMARY	1
INTRODUCTION	1
FORMULATION OF BOUNDARY-VALUE PROBLEM	4
The unsteady-flow problem	4
The equivalent steady-flow problem	4
Governing partial differential equation for rotational flow	4
Boundary conditions	6
Evaluation of rotation term in governing equation	8
SOLUTION FOR HORIZONTAL WAVE	10
Particular integral and complementary function	11
Evaluation of undetermined constants	11
Velocity components	12
Shock perturbation	13
SOLUTION WHEN FLOW DOWNSTREAM OF EQUIVALENT OBLIQUE SHOCK IS SUBSONIC ( $\bar{W} < 1$ )	13
Governing equation and particular integral	13
Complementary function	14
Velocity components with undetermined constants	15
Evaluation of undetermined constants	16
SOLUTION WHEN FLOW DOWNSTREAM OF EQUIVALENT OBLIQUE SHOCK IS SUPERSONIC ( $\bar{W} > 1$ )	17
Governing equation and particular integral	17
Complementary function	17
Velocity components with undetermined constants	18
Evaluation of undetermined constants	19
RESULTS AND DISCUSSION	20
Velocity Field	20
Pressure Field	24
Density Field	24
Shock-Wave Perturbation	25
Intensity of Sound Field	26
Generalization to Oblique Shocks	28
Related Problems	28
CONCLUDING REMARKS	29
APPENDIX A - SYMBOLS	31

	Page
APPENDIX B - LINEAR PERTURBATION THEORY FOR ROTATIONAL FLOW	34
Governing Equation	34
Pressure Field	36
Density Field	37
APPENDIX C - VARIANTS ON THE SHOCK RELATIONS	39

NATIONAL ADVISORY COMMITTEE FOR AERONAUTICS

---

TECHNICAL NOTE 2864

---

CONVECTION OF A PATTERN OF VORTICITY THROUGH A SHOCK WAVE

By H. S. Ribner

SUMMARY

An arbitrary weak spatial distribution of vorticity can be represented in terms of plane sinusoidal shear waves of all orientations and wave lengths (Fourier integral). The analysis treats the passage of a single representative weak shear wave through a plane shock and shows refraction and modification of the shear wave with simultaneous generation of an acoustically intense sound wave. Applications to turbulence and to noise in supersonic wind tunnels are indicated.

INTRODUCTION

Turbulence such as the residual small eddying motion in a wind-tunnel stream will gradually decay as it is carried along. The decay process has been the subject of much study in the face of formidable difficulties. The random character of the motions has been successfully handled by the methods of statistics; even with these methods, however, the nonlinearity of the equations governing the intermixing processes has severely limited the progress attainable without simplifying assumptions.

On the other hand, for relatively sudden changes in turbulence, such as occur when it passes through a wire-mesh damping screen, the decay may be negligible and the changes may follow linear laws. The linearity is assured if the turbulence constitutes a sufficiently small perturbation of the main stream. Recently it has been found that the problem of such linear changes could be solved completely by a specialized adaptation of the spectrum concept of the statistical theory of turbulence.

Several of these linear processes have been treated in this manner: the damping-screen problem (reference 1), the passage of turbulence through a sudden wind-tunnel contraction (reference 2), and the passage of turbulence through a series of screens followed by a sudden contraction (unpublished investigation of M. Tucker). A basic technique for such problems has been evolved in these papers.

The present paper is motivated by another problem of the same linear character, namely, the convection of weak turbulence through a shock wave. Among other circumstances, this problem arises in the interpretation of measurements with a hot-wire anemometer in a supersonic stream, because a detached bow wave stands ahead of the wire.<sup>1</sup> Such a curved shock is not attractive for theoretical analysis, but it is not difficult to replace it with an extended plane shock by use of auxiliary means; attention can thus be limited to the convection of turbulence through a plane shock.

The conceptual basis for the treatment of these linear problems is as follows: An arbitrary weak spatial distribution of vorticity - and hence a weak turbulent velocity field - can be represented as a superposition or spectrum of plane sinusoidal shear waves distributed among all orientations and wave lengths. This is a physical interpretation of the mathematical formulation as a Fourier integral;<sup>2</sup> the individual shear waves may be identified as Fourier or spectrum components. When the turbulence wave pattern is convected through a screen or through a shock wave, the individual waves are altered without mutual interference if the waves are suitably weak. Thus the modified field downstream of the screen or shock can be obtained, in principle, by superposition of the modified individual waves. In practice the description of the detailed spatial distribution of velocity, either initially or finally; is hopeless; the initial wave distribution is known only statistically (e.g., the phase angles are unknown), and statistical

---

<sup>1</sup>A simple interpretation for all but very small eddies comparable with the scale of the bow wave is, however, available in the work of Kovásznay (reference 3).

<sup>2</sup>The velocity field so represented may be either rotational or irrotational within the specified region, even though the "building blocks," the shear waves, are rotational. In case an irrotational field is represented, the vorticity of these shear waves, but not the velocity, mutually cancels within the specified region (which may be multiply connected), leaving a distribution of vorticity in the external space. The irrotational flow may be regarded as induced by this external vorticity.

These remarks all refer to a velocity field satisfying the incompressible continuity equation: a small-perturbation field of vorticity in fluid at rest, or convected by a main stream, will fulfill this condition.

changes only can be calculated. In either case the analysis of the behavior of a representative single wave constitutes a prerequisite to the determination of the changes in the weak turbulent field.

In the present paper such an analysis is carried out for a single shear wave, of arbitrary inclination, convected through a plane shock. There remains the task of calculating therefrom the changes in the statistical properties of a weak turbulent field convected through a shock.<sup>1</sup>

This single-wave problem is also treated in a current investigation by F. K. Moore (unpublished). The analyses bear little resemblance: In that work a reference frame is used in which the flow is unsteady, whereas herein a frame is used in which the flow is steady. Sound waves are likewise treated in the work cited.

The outline of the present analysis is as follows: The problem is posed as the calculation of the flow field behind a plane normal shock wave due to the convection through the shock of an inclined plane sinusoidal shear wave; the shear wave is specified to be weak to ensure small perturbations to the mean flow. This problem, for which the flow is unsteady in time, is converted into an equivalent steady-flow problem by transformation to a moving frame of reference. In this frame the normal shock is replaced by an equivalent oblique shock.

The analysis is now formulated as a boundary-value problem for the flow in the region downstream of the shock: The governing partial differential equation for this small-perturbation rotational flow is derived (extension of Sears' work, reference 4); boundary conditions on the velocity components just behind the shock are obtained from the oblique-shock relations; and finally the rotation term in the governing equation is evaluated in terms of gradients of entropy and total enthalpy, with use of the entropy changes across the shock. The initially unknown perturbation of the form of the shock wave is taken into account in the boundary conditions and rotation term by assuming it to be sinusoidal with initially undetermined amplitude and phase.

The velocity  $W$  (all symbols are defined in appendix A) downstream of this equivalent oblique shock may be either subsonic or supersonic depending on the inclination of the initial plane shear wave; separate solutions of the boundary-value problem are worked out for the two markedly different cases. The horizontal shear wave - which is a simple special case for subsonic  $W$  - is given a separate treatment.

---

<sup>1</sup>Procedures have been developed in references 1 and 2; an extension will be required if the noise field generated by the interaction is to be treated.

The analysis of the velocity field downstream of the shock is followed by an account of the associated pressure and density fields there and of the distortion of the initially plane shock. Finally, the acoustic level of the (fluctuating) pressure field is worked out in approximate fashion for an example applied to a supersonic wind tunnel: A particular initial intensity of turbulence is assumed and considered as being concentrated in a single shear wave rather than distributed throughout a continuous spectrum. The calculation amounts to an estimate of the noise level generated by the passage of a specified level of turbulence through a shock wave.

This investigation was conducted at the NACA Lewis laboratory.

#### FORMULATION OF BOUNDARY-VALUE PROBLEM

The unsteady-flow problem. - The inclined plane sinusoidal shear wave is shown schematically in figure 1. The flow is viewed in a plane perpendicular to the shock and to the wave fronts. The wave is supposed to be convected downstream by the main stream with velocity  $U_A$  so that it passes through the normal shock. The passage through the shock is evidently an unsteady process, since the intercepts of the inclined lines (the nodes of the sine wave) move downward along the shock front; it will be shown that a disturbance ripple moves along the shock with the same speed  $V$ .

In the general case of a plane oblique sinusoidal shear wave there will also exist a perturbation velocity component normal to the plane of the figure. Now the ripples in the shock front will be two dimensional, and the shock with the ripples will still be everywhere perpendicular to the plane of the figure. Thus, the normal velocity component will be parallel everywhere to the shock and will be unaffected as the shear wave passes through; the component will have no other effect. Its invariance established, this normal velocity component will be omitted from the analysis.

The equivalent steady-flow problem. - If an observer moves downward along the shock with a speed  $V$ , relative to him the flow will have an apparent upward velocity component  $V$ . This scheme of things is shown in figure 2. In particular,  $V$  has been chosen so that the resultant stream velocity (relative to the moving observer) is aligned with the velocity in the disturbance wave; that is,  $V = U_A \tan \theta$ . The observer then sees what appears to be a steady sinusoidal shear flow passing through an oblique shock wave. Thus, by the proper choice of a system of moving axes the original unsteady-flow problem has been converted into an equivalent steady-flow problem.

Governing partial differential equation for rotational flow. - The task of the analysis is to calculate the flow field on the downstream

side produced by the passage of the sinusoidal shear flow through the equivalent oblique shock. It is to be expected that the shock will be perturbed from its mean plane and will, in fact, develop a corrugated appearance. Because of these corrugations, vorticity (rotation) will be introduced into the downstream flow. This vorticity and all the downstream velocity perturbations will be weak compared with the stream velocity because the original disturbance wave has been assumed weak. Thus, a small-perturbation, or linearized, treatment of the flow field is permissible.

In reference 4 the governing partial differential equation for small-perturbation compressible rotational flow has been derived for isoenergetic flow, that is, for flow of constant stagnation enthalpy. However, the shear wave under consideration possesses variable stagnation enthalpy; that is, pressure, density, and temperature are constant upstream of the shock, but the velocity varies. It has been necessary, therefore, to obtain a more general governing equation that applies when both entropy and stagnation enthalpy are variable. The derivation is given in appendix B.

This governing equation is expressed in terms of coordinates  $\xi$  and  $\eta$ ,  $\xi$  being the distance in the main stream direction and  $\eta$  the distance perpendicular thereto. The equation reads

$$(1 - \bar{W}^2)\psi_{\xi\xi} + \psi_{\eta\eta} = \frac{H_{,\eta}}{W} - \frac{T_{s,\eta}}{W} = -\Omega \quad (1)$$

where  $W$  is the stream velocity in the transformed problem,  $\bar{W}$  is the corresponding Mach number,  $H$  is the stagnation enthalpy,  $s$  is the entropy,  $T$  is the temperature,  $\Omega$  is the vorticity, and  $\psi$  is a perturbation stream function such that

$$\left. \begin{aligned} \psi_{,\eta} &\equiv w = \text{perturbation velocity in } \xi \text{ direction} \\ -(1 - \bar{W}^2)\psi_{,\xi} &\equiv w' = \text{perturbation velocity in } \eta \text{ direction} \end{aligned} \right\} (2)$$

(The stream function is defined differently in reference 4, as it involves an entropy term.)

For application of equation (1) in the present problem reference should be made to figure 3 for the direction of the axes. In this figure  $W$  is the resultant stream velocity downstream of the shock (in the moving frame of reference), and the  $\xi$  and  $\eta$  axes are indicated. The final flow pattern depends crucially on whether  $W$  is subsonic or supersonic; the criterion depends, in turn, on the Mach number corresponding to  $U_A$  and on the wave inclination  $\theta$ .

Boundary conditions. - The boundary conditions just downstream of the shock will now be obtained by application of the shock-wave relations.

By geometry (fig. 4) the stream velocity components normal and tangential to the undisturbed shock are, respectively,

$$U_A = W_A \cos \epsilon$$

$$V = W_A \sin \theta$$

The shear wave will provide directly a perturbation  $w_A$  to  $W_A$  and will cause indirectly a perturbation  $\sigma(y)$  to the shock-wave angle, of initially undetermined magnitude. The effect of  $\sigma$  is equivalent to an increment in  $\theta$ . The associated perturbations to  $U_A$  and  $V$  are found by obtaining their respective differentials and replacing  $dW_A$  by  $w_A$  and  $d\theta$  by  $\sigma$  therein; the results are

$$\left. \begin{aligned} dU_A &= w_A \cos \theta - \sigma W_A \sin \theta \\ dV &= w_A \sin \theta + \sigma W_A \cos \theta \end{aligned} \right\} \quad (3)$$

The corresponding change in normal velocity  $U$  downstream of the shock is obtained from the normal-shock relation

$$\frac{U_A}{U} = \frac{\frac{\gamma + 1}{2} \bar{U}_A^2}{1 + \frac{\gamma - 1}{2} \bar{U}_A^2}$$

By logarithmic differentiation and use of the fact that the upstream temperature is constant (whence  $\frac{d\bar{U}_A}{\bar{U}_A} = \frac{dU_A}{U_A}$ ), there is finally obtained

$$\frac{dU}{U} = - \frac{dU_A}{U_A} \left( 1 - 2 \frac{\gamma - 1}{\gamma + 1} m \right) \quad (4)$$

where  $m \equiv U_A/U$ .

On the downstream side of the shock the velocity perturbations in the directions of  $\xi$  and  $\eta$ , respectively, are (fig. 4)

$$\left. \begin{aligned} w_o &= (U + dU) \cos(\varphi + \sigma) + (V + dV) \sin(\varphi + \sigma) - W \\ w_o' &= - (U + dU) \sin(\varphi + \sigma) + (V + dV) \cos(\varphi + \sigma) \end{aligned} \right\} \quad (5a)$$

Equations (3) and (4) may be used to evaluate the right-hand side of equation (5a). A first-order approximate result is obtained by taking  $\cos \sigma = 1$ ,  $\sin \sigma = \sigma$  and neglecting  $\sigma \tan \varphi$  and  $\sigma \cot \varphi$  in comparison with unity. It will be useful also to introduce the geometrical relation  $U_A = W_A \cos \theta$ , the definition  $U_A/U = m$ , and to eliminate  $\theta$  by means of the oblique-shock relation  $\tan \varphi = m \tan \theta$ . The final rearranged result is

$$\left. \begin{aligned} \frac{w_o}{U} &= - \left( \frac{w_A}{W_A} - \frac{\sigma}{m} \tan \varphi \right) \left( 1 - 2 \frac{\gamma-1}{\gamma+1} m \right) \cos \varphi + \left( \frac{w_A}{W_A} \tan \varphi + m\sigma \right) \sin \varphi \\ \frac{w_o'}{U} &= \left( \frac{w_A}{W_A} - \frac{\sigma}{m} \tan \varphi \right) \left( 1 - 2 \frac{\gamma-1}{\gamma+1} m \right) \sin \varphi + \left( \frac{w_A}{W_A} \tan \varphi + m\sigma \right) \cos \varphi - \sigma \sec \varphi \end{aligned} \right\} \quad (5)$$

These are the desired boundary conditions in a somewhat general form.

In the present problem the perturbation  $w_A$  is associated with an incident sinusoidal shear wave parallel to  $W_A$  (or to  $\xi_A$ ) (figs. 2 and 3). It will be shown later that a refracted sinusoidal shear wave parallel to  $W$  (or to  $\xi$ ) will also arise. A suitable defining equation for  $w_A$  is

$$\frac{w_A}{W_A} = \epsilon \cos k\eta_A \quad (6)$$

where  $k$  is the wave number ( $2\pi/k =$  wave length). The corresponding argument for the refracted shear wave will involve  $\eta$  and an altered wave number  $\kappa$ . The argument of the upstream and downstream waves must match along the shock front, so that

$$k\eta_A = \kappa\eta \quad \text{along shock}$$

(By geometry (fig. 3),  $\frac{k}{\kappa} = \frac{\cos \varphi}{\cos \theta}$ .) Thus

$$\frac{w_A}{W_A} = \epsilon \cos \kappa\eta \quad \text{along shock} \quad (7)$$

Since the disturbance is sinusoidal, the shock inclination  $\sigma$  can likewise be expected to be sinusoidal. For generality a phase shift can be allowed for, so that  $\sigma$  can be assumed to have the form

$$\sigma = \epsilon(a \cos \kappa \eta + b \sin \kappa \eta) \quad (8)$$

Substitution of these sinusoidal relations into the general form of the boundary conditions, equations (5), yields, after rearrangement,

$$\frac{w_0}{\epsilon U} = \left[ \frac{a}{m} \left( 1 - 2 \frac{\gamma-1}{\gamma+1} m + m^2 \right) \sin \phi - \left( 1 - 2 \frac{\gamma-1}{\gamma+1} m \right) \cos \phi + \frac{\sin^2 \phi}{\cos \phi} \right] \cos \kappa \eta + \left[ \frac{b}{m} \left( 1 - 2 \frac{\gamma-1}{\gamma+1} m + m^2 \right) \sin \phi \right] \sin \kappa \eta$$

$$\frac{w_0'}{\epsilon U} = \left[ - \frac{a}{m} \left( 1 + \frac{3-\gamma}{\gamma+1} m \right) \frac{\sin^2 \phi}{\cos \phi} + a(m-1) \cos \phi + 2 \left( 1 - \frac{\gamma-1}{\gamma+1} m \right) \sin \phi \right] \cos \kappa \eta + \left[ - \frac{b}{m} \left( 1 + \frac{3-\gamma}{\gamma+1} m \right) \frac{\sin^2 \phi}{\cos \phi} + b(m-1) \cos \phi \right] \sin \kappa \eta$$

(9)

Equations (9) give, in final form, the conditions imposed by the shock wave on the components parallel to  $\xi$  and  $\eta$ , respectively, of the perturbation velocity immediately behind the shock; the parameters  $a$  and  $b$  therein governing the shock inclination  $\sigma$  are undetermined. These equations constitute the boundary conditions for the perturbation flow downstream of the shock.

Evaluation of rotation term in governing equation. - Before equation (1) can be solved, the vorticity term (rotation term) on the right-hand side must be evaluated for the region behind the shock. A corresponding term has been evaluated in reference 5 for the flow behind a normal shock perturbed by an isoenergetic upstream disturbance. This work has proved a useful guide, but it has been necessary to make modifications both for the variation in energy (that is, in total enthalpy  $H$ ) and for the inclination of the shock in the moving frame of reference. The derivation is as follows:

Downstream of the shock, the enthalpy  $H$  and the entropy  $s$  (and hence the vorticity) are constant along streamlines, and in the linear theory the streamlines are approximated by lines  $\eta = \text{constant}$ . Thus,  $\frac{\partial H}{\partial \eta}$  and  $\frac{\partial s}{\partial \eta}$  may be evaluated at the shock and the result will

hold downstream thereof if expressed as a function of  $\eta$  alone ( $\xi$  eliminated).

The total enthalpy upstream and at the shock is

$$H = c_p T_A + \frac{1}{2} (W_A + w_A)^2$$

$$\approx c_p T_A + \frac{1}{2} W_A^2 \left( 1 + \frac{2w_A}{W_A} \right)$$

Hence, at the shock

$$\frac{\partial H}{\partial \eta} = W_A^2 \frac{\partial}{\partial \eta} \left( \frac{w_A}{W_A} \right)_{\text{along shock}} \tag{10}$$

The entropy upstream of the shock is constant by virtue of the assumption of constant pressure and density there. The entropy change in crossing the shock is given in terms of the upstream velocity by (reference 6, equation 144):

$$s - s_A = \frac{R}{\gamma - 1} \ln \left\{ \left[ \frac{2\gamma}{\gamma + 1} (\bar{w}_A + \bar{w}_A)^2 \cos^2(\theta + \sigma) - \frac{\gamma - 1}{\gamma + 1} \right] \left[ \frac{(\gamma - 1)(\bar{w}_A + \bar{w}_A)^2 \cos^2(\theta + \sigma) + 2}{(\gamma + 1)(\bar{w}_A + \bar{w}_A)^2 \cos^2(\theta + \sigma)} \right]^\gamma \right\}$$

Hence, on writing the differential and expanding the result under the assumption that  $T_A$  is constant and  $w_A/W_A$  and  $\sigma$  are small, there is obtained

$$\delta s = \frac{U^2}{T} (m - 1)^2 \left( \frac{w_A}{W_A} - \sigma \tan \theta \right) \tag{11a}$$

and

$$\frac{\partial s}{\partial \eta} = \frac{U^2}{T} (m - 1)^2 \frac{\partial}{\partial \eta} \left( \frac{w_A}{W_A} - \sigma \tan \theta \right) \tag{11}$$

Recall now that the governing equation (1) reads

$$(1 - \bar{w}^2) \psi_{\xi\xi} + \psi_{\eta\eta} = \frac{H_\eta}{W} - \frac{T s_\eta}{U}$$

where the right-hand side is the rotation term in question. The factors  $H_\eta$  and  $s_\eta$  have been evaluated in equations (10) and (11a), respectively; substitution with use of the geometrical relations of figure 3 yields

$$(1 - \bar{W}^2)\psi_{\xi\xi} + \psi_{\eta\eta} = Um^2 \frac{\cos \phi}{\cos^2 \theta} \frac{\partial}{\partial \eta} \left( \frac{w_A}{W_A} \right) - U \cos \phi (m - 1)^2 \frac{\partial}{\partial \eta} \left( \frac{w_A}{W_A} - \sigma \tan \theta \right) \quad (12)$$

where the right-hand side is to be evaluated along the shock ( $x = 0$ ) and expressed as a function of  $\eta$  alone.

In the form (12) the governing equation has not yet been specialized to a shear flow that is sinusoidal. The substitution of equations (7) and (8) for  $w_A/W_A$  and  $\sigma$ , respectively, introduces the sinusoidal character; furthermore, the relation  $\tan \phi = m \tan \theta$  can be used to eliminate  $\theta$ ; after simplification

$$(1 - \bar{W}^2)\psi_{\xi\xi} + \psi_{\eta\eta} = U\epsilon \left\{ -x \left[ \sec \phi + 2(m - 1) \cos \phi + a \frac{(m - 1)^2}{m} \sin \phi \right] \sin x\eta + xb \frac{(m - 1)^2}{m} \sin \phi \cos x\eta \right\} \quad (13)$$

Equation (13) is the partial differential equation to be satisfied by the flow downstream of the shock subject to the boundary conditions (equations (9)).

#### SOLUTION FOR HORIZONTAL WAVE

The governing equation and boundary conditions have been set up for the general case of an inclined shear wave. It will be worthwhile to solve first, however, the much simpler special case of the horizontal shear wave. The results will illustrate important features of the general case as well as provide a limiting case of the general solution, useful as a check.

The horizontal wave is obtained by setting  $\theta = \phi = 0$  in the earlier equations; as a consequence  $V \rightarrow 0$ ,  $W \rightarrow U$ ,  $\xi \rightarrow x$ ,  $\eta \rightarrow y$ , and  $x \rightarrow k$ . The governing equation reduces to

$$\beta^2 \psi_{xx} + \psi_{yy} = -kU\epsilon(2m - 1) \sin ky \quad (14)$$

where

$$\beta^2 \equiv 1 - \bar{U}^2$$

The boundary conditions (equation (9)) reduce to

$$\left. \begin{aligned} \frac{w_0}{U\epsilon} = \frac{u_0}{U\epsilon} &= - \left( 1 - 2 \frac{\gamma - 1}{\gamma + 1} m \right) \cos ky \\ \frac{w_0'}{U\epsilon} = \frac{v_0}{U\epsilon} &= (m - 1) a \cos ky + (m - 1) b \sin ky \end{aligned} \right\} \quad (15)$$

Particular integral and complementary function. - A particular integral of equation (14) may be obtained by inspection as

$$\psi_P = \frac{U\epsilon}{k} (2m - 1) \sin ky$$

To obtain a complete solution there must be added a complementary function satisfying equation (14) with the right-hand side set equal to zero. The boundary conditions at  $x = 0$  require that the function possess a sinusoidal variation with  $y$ . Such a solution will also contain an exponential factor, showing either amplification or attenuation of the disturbance with distance  $x$  downstream of the shock; the case of amplification must be ruled out as physically unacceptable. These considerations limit the solution to the form

$$\psi_C = U\epsilon d e^{-\frac{kx}{\beta}} \sin ky$$

where  $d$  is a constant of integration.

The complete solution is the sum of  $\psi_P$  and  $\psi_C$ :

$$\psi = U\epsilon \left( \frac{2m - 1}{k} + d e^{-\frac{kx}{\beta}} \right) \sin ky \quad (16)$$

Evaluation of undetermined constants. - The velocity components are obtained from equation (16) as

$$\left. \begin{aligned} u = \psi_y &= U\epsilon \left( 2m - 1 + k d e^{-\frac{kx}{\beta}} \right) \cos ky \\ v = -\beta^2 \psi_x &= \beta U \epsilon k d e^{-\frac{kx}{\beta}} \sin ky \end{aligned} \right\} \quad (17)$$

The undetermined constants  $a$ ,  $b$ , and  $d$  are evaluated by setting  $x = 0$  and comparing with the boundary conditions, equations (15), equating the respective coefficients of  $\sin ky$  and  $\cos ky$ . The results are

2666

$$\left. \begin{aligned} a &= 0 \\ b &= -\frac{4\beta m}{(\gamma + 1)(m - 1)} \\ d &= -\frac{4m}{k(\gamma + 1)} \end{aligned} \right\} \quad (18)$$

Velocity components. - Insertion of the value of  $d$  into equation (17) yields the final result for the velocity components valid everywhere downstream of the shock

$$\left. \begin{aligned} u &= U\epsilon \left[ 2m - 1 - \frac{4m}{\gamma + 1} e^{-\frac{kx}{\beta}} \right] \cos ky \\ v &= -\beta U\epsilon \frac{4m}{\gamma + 1} e^{-\frac{kx}{\beta}} \sin ky \end{aligned} \right\} \quad \text{all } x \geq 0 \quad (19)$$

Just behind the shock

$$\left. \begin{aligned} u_0 &= U\epsilon \left( -1 + 2 \frac{\gamma - 1}{\gamma + 1} m \right) \cos ky \\ v_0 &= -\beta U\epsilon \frac{4m}{\gamma + 1} \sin ky \end{aligned} \right\} \quad x = 0 \quad (19a)$$

and far downstream

$$\left. \begin{aligned} u_\infty &= U\epsilon(2m - 1) \cos ky \\ v_\infty &= 0 \end{aligned} \right\} \quad x = \infty \quad (19b)$$

These results and the associated streamline pattern are exhibited pictorially in figure 5.

These perturbation velocity components downstream of the shock are to be compared with the corresponding velocity components in the shear flow upstream of the shock (cf. equation (7))

$$\left. \begin{aligned} u_A &= U_A \epsilon \cos ky \\ &= U\epsilon m \cos ky \\ v_A &= 0 \end{aligned} \right\}$$

The ratio of  $u_{\infty}/u_A$  is

$$\frac{u_{\infty}}{u_A} = 2 - \frac{1}{m} \quad (20)$$

Since  $m \equiv U_A/U \geq 1$  in order that a normal shock exist, it appears from equation (20) that the normal shock always amplifies the horizontal shear wave, the maximum amplification of  $\frac{\gamma + 3}{\gamma + 1}$  being approached as the initial Mach number approaches infinity.

Shock perturbation. - The local inclination of the shock from the vertical is given by equation (8). With the previously determined values of  $a$  and  $b$  (equation (18)) inserted, and with  $ky$  in place of  $x\eta$ , the inclination is

$$\sigma = - \frac{4\beta\epsilon m}{(\gamma + 1)(m - 1)} \sin ky$$

If the local shock displacement in the  $x$ -direction relative to the mean shock plane is called  $\delta x(y)$ , then

$$\begin{aligned} \delta x &= \int \sigma \, dy \\ &= \frac{4\beta\epsilon m}{k(\gamma + 1)(m - 1)} \cos ky \end{aligned} \quad (21)$$

Thus the shock displacement curve is in phase with the velocity perturbation in the shear wave upstream of the shock (fig. 5).

#### SOLUTION WHEN FLOW DOWNSTREAM OF EQUIVALENT OBLIQUE

##### SHOCK IS SUBSONIC ( $\bar{W} < 1$ )

The present case is a generalization from the horizontal wave just discussed to a wave of arbitrary inclination  $\theta$ . The restriction to a subsonic mean velocity  $W$  behind the equivalent oblique shock insures a qualitative similarity of the flow: the governing equation is elliptic in both cases. Accordingly, the horizontal-wave result can serve as a guide.

Governing equation and particular integral. - The governing differential equation (13) may be written in abbreviated form as

$$\beta_w^2 \psi_{\xi\xi} + \psi_{\eta\eta} = -\kappa U \epsilon (A \sin \kappa \eta - B \cos \kappa \eta) \quad (22)$$

where

$$\left. \begin{aligned} A &\equiv \left[ \sec \phi + 2(m-1) \cos \phi + a \frac{(m-1)^2}{m} \sin \phi \right] \\ B &\equiv b \frac{(m-1)^2}{m} \sin \phi \\ \beta_w^2 &\equiv 1 - \bar{W}^2 \end{aligned} \right\} \quad (23)$$

A particular integral is seen to be

$$\psi_P = U \epsilon \left( \frac{A}{\kappa} \sin \kappa \eta - \frac{B}{\kappa} \cos \kappa \eta \right) \quad (24)$$

Complementary function. - From the result for the horizontal wave the complementary function should be expected to attenuate exponentially downstream of the shock, and from physical considerations the attenuation should depend upon the distance measured normal to the shock front, that is, upon  $x$  rather than, say,  $\xi$ . The functional form that has the desired attenuation and possesses a sinusoidal behavior at the shock is

$$\psi_C \sim e^{-\alpha \beta_w (\xi \cos \phi - \eta \sin \phi)} \left\{ \begin{array}{l} \sin \\ \text{or} \\ \cos \end{array} \left[ \alpha (\xi \sin \phi + \beta_w^2 \eta \cos \phi) \right] \right\} \quad (25)$$

where  $\xi \cos \phi - \eta \sin \phi$  may be recognized as just  $x$ .

The arbitrary constant  $\alpha$  in equation (25) is determined by a consideration of the boundary conditions (equation (9)): the argument of the cosine must reduce to  $\kappa \eta$  along the shock front, where  $\xi = \eta \tan \phi$ . This requirement gives  $\alpha = \kappa \cos \phi / \beta_w^2$ . Finally, when constants of integration  $c'$  and  $d'$  are included, the complementary function is written as

$$\psi_C = U \epsilon e^{-\frac{\kappa \beta_w}{\beta^2} \cos \phi (\xi \cos \phi - \eta \sin \phi)} \left\{ \left[ c' \cos \frac{\kappa \cos \phi}{\beta^2} (\xi \sin \phi + \beta_w^2 \eta \cos \phi) \right] + \left[ d' \sin \frac{\kappa \cos \phi}{\beta^2} (\xi \sin \phi + \beta_w^2 \eta \cos \phi) \right] \right\} \quad (26)$$

Velocity components with undetermined constants. - The complete solution for the perturbation stream function is

$$\psi = \psi_P + \psi_C$$

This expression (cf. equations (24) and (26)) contains four arbitrary parameters  $a$  and  $b$  (which occur in  $A$  and  $B$ , respectively, equation (23)) and  $c'$  and  $d'$ , which remain to be determined. First the corresponding expressions for the velocity components will be obtained - they will be needed anyway - and then the boundary conditions on these velocities at the shock wave will be applied for the determination of  $a$ ,  $b$ ,  $c'$ , and  $d'$ .

The perturbation velocity components in the direction of  $\xi$  and  $\eta$  are  $w = \psi_\eta$  and  $w' = -\beta_w^2 \psi_\xi$ , respectively; by differentiation of equations (24) and (26) there results

$$\left. \begin{aligned} \frac{w}{U\epsilon} &= A \cos \kappa \eta + B \sin \kappa \eta + \beta^{-2} e^{-\frac{\kappa \beta_w}{\beta^2} \cos \phi (\xi \cos \phi - \eta \sin \phi)} \times \\ &\left[ (c \sin \phi + d \beta_w \cos \phi) \cos \frac{\kappa \cos \phi (\xi \sin \phi + \beta_w^2 \eta \cos \phi)}{\beta^2} + \right. \\ &\left. (-c \beta_w \cos \phi + d \sin \phi) \sin \frac{\kappa \cos \phi (\xi \sin \phi + \beta_w^2 \eta \cos \phi)}{\beta^2} \right] \\ \frac{w'}{U\epsilon} &= \beta^{-2} e^{-\frac{\kappa \beta_w}{\beta^2} \cos \phi (\xi \cos \phi - \eta \sin \phi)} \times \\ &\left[ (c \beta_w^2 \cos \phi - d \beta_w \sin \phi) \cos \frac{\kappa \cos \phi (\xi \sin \phi + \beta_w^2 \eta \cos \phi)}{\beta^2} + \right. \\ &\left. (c \beta_w \sin \phi + d \beta_w^2 \cos \phi) \sin \frac{\kappa \cos \phi (\xi \sin \phi + \beta_w^2 \eta \cos \phi)}{\beta^2} \right] \end{aligned} \right\} (27)$$

where  $c'$  and  $d'$  have been absorbed for convenience into new constants

$$c \equiv c' \kappa \beta_w \cos \phi$$

$$d \equiv d' \kappa \beta_w \cos \phi$$

The undetermined constants may now be considered as  $a$ ,  $b$ ,  $c$ , and  $d$ .

Conditions along the shock on the downstream side have been designated by subscript zero; here  $\xi \cos \phi = \eta \sin \phi$ , and the arguments of the exponential and sine and cosine terms reduce to zero and  $\kappa \eta$  respectively:

$$\left. \begin{aligned} \frac{w_0}{U\epsilon} &= \left( A + \frac{c}{\beta^2} \sin \phi + \frac{d}{\beta^2} \beta_w \cos \phi \right) \cos \kappa \eta + \\ &\quad \left( B - \frac{c}{\beta^2} \beta_w \cos \phi + \frac{d}{\beta^2} \sin \phi \right) \sin \kappa \eta \\ \frac{w_0'}{U\epsilon} &= \beta^{-2} (c\beta_w^2 \cos \phi - d\beta_w \sin \phi) \cos \kappa \eta + \\ &\quad \beta^{-2} (c\beta_w \sin \phi + d\beta_w^2 \cos \phi) \sin \kappa \eta \end{aligned} \right\} \quad (28)$$

Evaluation of undetermined constants. - Equations (28) must agree identically with the boundary conditions (equations (9)) imposed by the shock wave on  $w_0$  and  $w_0'$ . Therefore the respective coefficients of  $\sin \kappa \eta$  and  $\cos \kappa \eta$  are to be equated; this yields four simultaneous equations for the four undetermined constants  $a$ ,  $b$ ,  $c$ , and  $d$ . In the reduction of the solution to final form certain alternative forms of the oblique-shock relations, given in appendix C, have been used. The results are

$$\left. \begin{aligned} a &= m \frac{CE + DF}{C^2 + D^2} \\ b &= m \frac{CF - DE}{C^2 + D^2} \\ c &= \frac{a}{m} D' - F' \\ d &= \frac{b}{m} D' \end{aligned} \right\} \quad (29)$$

where

$$\left. \begin{aligned}
 C &\equiv \left( \frac{\gamma - 1}{\gamma + 1} + \frac{3 - \gamma}{\gamma + 1} m \right) \tan \phi - \left[ (m - 1)^2 + \frac{2(m - 1)}{\gamma + 1} \right] \sin \phi \cos \phi \\
 D &\equiv \frac{\beta_w}{\beta^2} (m - 1) \left[ 1 + (m - 1) \cos^2 \phi \right] \equiv \frac{\beta_w}{\beta^2} D' \\
 E &\equiv 2 \left( 1 - \frac{\gamma - 1}{\gamma + 1} m \right) + 2(m - 1) \frac{\beta_w^2 \cos^2 \phi}{\beta^2} \\
 F &\equiv \frac{\beta_w}{\beta^2} \left[ 2(m - 1) \sin \phi \cos \phi \right] \equiv \frac{\beta_w}{\beta^2} F'
 \end{aligned} \right\} (30)$$

SOLUTION WHEN FLOW DOWNSTREAM OF EQUIVALENT OBLIQUE

SHOCK IS SUPERSONIC ( $\bar{W} > 1$ )

When the mean velocity  $W$  behind the equivalent oblique shock is supersonic, the solution must exhibit Mach waves. If the cross-stream velocity  $V$  of the moving reference frame is subtracted out, these waves appear to be moving downward (cross-stream) with the velocity  $V$ . If another transformation of axes is made so that the reference frame is "convected" downstream with the stream velocity  $U$ , then the Mach waves can be identified as plane sound waves moving normal to the wave fronts with sonic velocity. Mach waves and plane sound waves are, of course, the same phenomena viewed relative to different frames of reference.

Governing equation and particular integral. - The governing equation (22) changes from elliptic to hyperbolic when  $\bar{W}$  exceeds unity (that is, when  $W$  is supersonic). The particular integral is unchanged thereby and is still given by equation (24). It is found that the final solution yields  $b = 0$  (and hence  $B = 0$ ), and so it is convenient to delete the  $B$ -term at the outset; the particular integral is thus

$$\psi_p = \frac{U\epsilon A}{\kappa} \sin \kappa \eta$$

Complementary function. - The complementary function satisfying equation (22) must be of the general form

$$\psi_c = f(\xi + \beta_w \eta) + g(\xi - \beta_w \eta)$$

where  $\beta_w \equiv \sqrt{\bar{W}^2 - 1}$ .

The function  $f$  represents Mach waves inclined downward by the Mach angle  $\mu$  from the  $\xi$ -axis and the function  $g$  represents Mach waves inclined upward by the Mach angle. If attention is restricted to the range of shear-wave inclinations  $0 \leq \theta \leq \frac{\pi}{2}$ , then the  $g$ -family of Mach waves can

be shown to represent disturbances overtaking the shock wave from behind. This property is related to the fact that, for a finite shock strength, the Mach angle is always greater than the angle between the shock and the  $\xi$ -axis. Since the disturbances actually originate at the shock wave by virtue of the passage therethrough of the initial shear wave, such Mach waves cannot arise, and the  $g$ -function must be zero. In what follows it will suffice to limit the discussion to the specified range  $0 \leq \theta \leq \frac{\pi}{2}$ , since the results for the remaining range  $0 \geq \theta \geq -\frac{\pi}{2}$  are readily obtained therefrom from symmetry considerations.

The function  $f$  must reduce to

$$f \sim \sin \kappa \eta$$

along the shock front, where  $\xi = \eta \tan \varphi$ , in order to satisfy the boundary conditions (with  $b = 0$ ). A suitable complementary function is therefore

$$\psi_C = \frac{U \varepsilon c''}{\kappa} \sin \frac{\kappa(\xi + \beta_w \eta)}{\beta_w + \tan \varphi}$$

where  $c''$  is a constant of integration.

The complete solution for the perturbation stream function is thus

$$\psi = \psi_P + \psi_C = \frac{U \varepsilon}{\kappa} \left[ A \sin \kappa \eta + c'' \sin \frac{\kappa(\xi + \beta_w \eta)}{\beta_w + \tan \varphi} \right] \quad (31)$$

This expression contains two arbitrary parameters  $a$  (occurring in  $A$ ) and  $c''$  which remain to be determined. First the corresponding expressions for the velocity components will be obtained, and then the boundary conditions on these velocities at the shock wave will be applied for the determination of  $a$  and  $c''$ .

Velocity components with undetermined constants. - The perturbation velocity components in the direction of  $\xi$  and  $\eta$  are  $w = \psi_\eta$  and  $w' = \beta_w^2 \psi_\xi$ , respectively; the expressions are

$$\left. \begin{aligned} \frac{w}{U \varepsilon} &= \left[ A \cos \kappa \eta + \frac{c \sec \varphi}{\beta_w + \tan \varphi} \cos \frac{\kappa(\xi + \beta_w \eta)}{\beta_w + \tan \varphi} \right] \\ \frac{w'}{U \varepsilon} &= \frac{\beta_w c \sec \varphi}{\beta_w + \tan \varphi} \cos \frac{\kappa(\xi + \beta_w \eta)}{\beta_w + \tan \varphi} \end{aligned} \right\} \quad (32)$$

where the constant  $c''$  has been absorbed into a new constant  $c \equiv c'' \beta_w \cos \phi$ . The undetermined constants are now  $a$  and  $c$ .

Along the shock  $\xi = \eta \tan \phi$ , and the arguments of all cosine terms reduce to  $\kappa \eta$ ; the expressions for the velocity components  $w$  and  $w'$  become

$$\left. \begin{aligned} \frac{w_0}{U \epsilon} &= \left( A + \frac{c \sec \phi}{\beta_w + \tan \phi} \right) \cos \kappa \eta \\ \frac{w_0'}{U \epsilon} &\equiv \frac{\beta_w c \sec \phi}{\beta_w + \tan \phi} \cos \kappa \eta \end{aligned} \right\} \quad (33)$$

Evaluation of undetermined constants. - Equations (33) must agree identically with the boundary conditions (equation (9)) imposed by the shock wave on  $w_0$  and  $w_0'$ . If the respective coefficients of  $\sin \kappa \eta$  and  $\cos \kappa \eta$  are equated, there results  $b = 0$  and two simultaneous equations for  $a$  and  $c$ . Thus, the initial specification of  $b = 0$  has been justified a posteriori.

The solutions may be written in the form

$$\left. \begin{aligned} a &= m \frac{C' + GF'}{E' + GD'} \\ c &= \frac{a}{m} D' - F' \end{aligned} \right\} \quad (34)$$

where

$$\left. \begin{aligned} C' &\equiv 2 \frac{\gamma - 1}{\gamma + 1} m - 2 \left[ 1 + (m - 1) \cos^2 \phi \right] \\ D' &\equiv (m - 1) \left[ 1 + (m - 1) \cos^2 \phi \right] \\ E' &\equiv (m - 1)^2 \sin \phi \cos \phi - \left( 1 + \frac{3 - \gamma}{\gamma + 1} m \right) \tan \phi \\ F' &\equiv 2(m - 1) \sin \phi \cos \phi \\ G &\equiv \frac{1 - \beta_w \tan \phi}{\beta_w + \tan \phi} = \tan (\mu - \phi) \end{aligned} \right\} \quad (35)$$

where  $\mu = \cot^{-1} \beta_w$  is the Mach angle. (The definitions for  $D'$  and  $F'$  herein are unchanged from those included in equation (30).)

## RESULTS AND DISCUSSION

## Velocity Field

The velocity field downstream of the shock wave, produced by convection of an oblique sinusoidal shear wave through the shock, has been calculated; the results are distributed through the preceding sections. The main results will now be presented in more compact form, simplified to aid in the geometrical interpretation. (The special case of the horizontal shear wave was discussed earlier.)

Frames of reference. - The analysis has been carried out in a special frame of reference in which the flow is steady; all formulas will be given relative to this steady-flow frame. Also of considerable interest is a frame of reference convected by the mean flow downstream of the shock; this frame is at rest relative to the general mass of fluid there. The relation between the two frames is shown in figure 6. Formulas relative to the steady-flow frame may be converted to apply to the convected frame by means of the transformations

$$\left. \begin{array}{l} \xi \rightarrow \xi + Wt \\ \eta \rightarrow \eta \\ x \rightarrow x + Ut \\ y \rightarrow y + Vt \end{array} \right\} \quad (36)$$

The criterion on  $\bar{W}$ . - Although the stream velocity  $U$  downstream of the specified normal shock (fig. 1) is always subsonic, the nature of the flow depends primarily on the stream velocity  $W$  downstream of the equivalent oblique shock (figs. 2 and 3), which may be either subsonic or supersonic. The velocity  $W$  may also be interpreted as the relative velocity of the steady-flow frame of reference and the convected frame (fig. 6). Two forms of the solution for all flow quantities thus appear, one for the subsonic range  $\bar{W} < 1$ , the other for the supersonic range  $\bar{W} > 1$ . The dividing line  $\bar{W} = 1$  is what has been designated "the criterion on  $\bar{W}$ " at the head of this section. Since  $\bar{W}$  depends on the initial Mach number  $\bar{U}_A$  and the inclination  $\theta$ , the equation  $\bar{W} = 1$  gives, in effect, a relation between a critical value of  $\theta$  and  $\bar{U}_A$ . The relation is conveniently expressed in terms of  $m \equiv U_A/U$ , which depends on  $\bar{U}_A$  (see appendix C):

$$\theta_{cr} = \pm \tan^{-1} \sqrt{\frac{(\gamma + 1)(m - 1)}{2m^2}} \quad (37)$$

A graph of  $|\theta_{cr}|$  versus  $\bar{U}_A$  is given in figure 7.

Resultant velocity,  $\bar{W} < 1$ . - Equations (27) may be recast in the form

$$\left. \begin{aligned} \frac{w}{|w_A|} &= S \cos \left[ \kappa_y (y - x \tan \phi) + \delta_s \right] + \Pi(x) \cos \left[ \kappa_y (y - x \tan \phi') + \delta_p \right] \\ \frac{w'}{|w_A|} &= \beta_w \Pi(x) \sin \left[ \kappa_y (y - x \tan \phi') + \delta_p \right] \end{aligned} \right\} \quad (38a)$$

where

$|w_A| \equiv W_A \epsilon =$  amplitude of sinusoidal velocity  $w_A$  in initial shear wave

$$\kappa_y = \kappa \cos \phi = k \cos \theta$$

$$S \equiv \frac{\cos \theta}{m} \sqrt{A^2 + B^2}; \quad A = A(a), \quad B = B(b)$$

$$\Pi(x) \equiv \frac{\cos \theta}{m} \frac{\sqrt{c^2 + d^2}}{\beta} e^{-x \kappa_y \beta_w / \beta^2}$$

$$\delta_s = \tan^{-1} \left( \frac{-B}{A} \right)$$

$$\phi' = - \tan^{-1} \frac{\bar{U}^2 \tan \phi}{\beta^2}$$

$$\delta_p = \tan^{-1} \frac{c \beta_w - d \tan \phi}{d \beta_w - c \tan \phi}$$

The functions A and B are given by equations (23) and a, b, c, and d are the initially undetermined constants which have been evaluated in equations (29) and (30).

Resultant velocity,  $\bar{W} > 1$ . - Equations (32) may be recast as well as generalized to apply for both positive and negative values of  $\phi$  as follows:

$$\left. \begin{aligned} \frac{w}{|w_A|} &= S \cos \kappa_y (y - x \tan \phi) + \Pi \cos \kappa_y (y - x \tan \phi') \\ \frac{w'}{|w_A|} &= \beta_w \Pi \cos \kappa_y (y - x \tan \phi') \end{aligned} \right\} \quad (38b)$$

where

$|w_A| \equiv W_A \epsilon =$  amplitude of sinusoidal velocity  $w_A$  in  
initial shear wave

$$S \equiv \frac{\cos \theta}{m} A; \quad A = A(a)$$

$$x_y = x \cos \phi = k \cos \theta$$

$$\Pi = \frac{\cos \theta}{m} c \frac{\sin \mu}{\sin(\mu + \phi)}$$

$\phi'$  = angle of magnitude  $(|\phi| - \mu)$  and has the same sign as  $\phi$

$$\mu = \text{Mach angle} = \cot^{-1} \beta_w$$

The function  $A$  is still given by equations (23), and  $a$  and  $c$  are evaluated in equations (34) and (35).

Shear-wave component. - The cosine in the  $S$ -term is constant along lines  $y - x \cot \phi = \text{constant}$ ; such lines are inclined at an angle  $\phi$  with the horizontal and are thus parallel to the  $\xi$ -axis. Since  $w$  is parallel to  $\xi$  and  $w'$  is parallel to  $\eta$ , it is seen that the  $S$ -term represents a pure shear flow parallel to the  $\xi$ -axis. Stated otherwise, this is a rotational flow; the rotation (or vorticity) is just  $\Omega$ , which was evaluated earlier in terms of gradients of entropy and total enthalpy (cf. equations (1) and (13)). The shear flow may be described also as an incompressible, plane, transverse, sinusoidal wave.

The amplitude and phase of the shear wave are compared with those of the initial shear wave in figure 8 for an initial Mach number of 1.5. The amplitude amplification ratio is  $S$  and the angle of phase lead is  $\delta_s$ ; both are plotted against the initial wave inclination  $\theta$ . There is seen to be a small phase lead in the subsonic range ( $\bar{W} < 1$ ) and none at all in the supersonic range ( $\bar{W} > 1$ ). The amplification is nowhere less than unity, with a cusp-like peak of 1.73 at the sonic point  $\bar{W} = 1$ .

Pressure-wave component. - The remaining terms in equations (38a) and (38b), involving the factor  $\Pi$ , correspond to an irrotational velocity field, or potential flow. That is, if the derivation is traced backward, the  $\Pi$ -terms are found to have come from the complementary function, which is a solution of the governing equation with the vorticity  $\Omega$  set equal to zero. This part of equations (38a) and (38b) defines what may be called a pressure wave since there is associated with it a first-order pressure field: the shear wave contributes nothing to the pressure.

The pressure wave may be interpreted as a distribution of sound waves. This interpretation is particularly evident for the case  $\bar{W} > 1$ , where the solution has been obtained in the form of Mach waves: if a transformation is made from the present special frame of reference, relative to which the flow is steady in time, to a frame moving with the general stream, then the Mach waves will reappear as plane sound waves moving normal to themselves with sonic speed.

The same transformation results in somewhat more complication when  $\bar{W} < 1$ : the resultant pressure pattern does not then propagate with the speed of sound, but it can be represented (as can any two-dimensional irrotational gas-flow field) as a superposition of cylindrical sound waves which individually propagate with sonic speed. The associated velocity pattern in this case exhibits the following features, which are brought out by an examination of equations (38a): The radius vector in a graph of  $w'$  versus  $w$  (hodograph) moves in an ellipse when  $x$  is held fixed and  $y$  varied; the major and minor axes are  $\Pi |w_A|$  and  $\beta_w \Pi |w_A|$ , respectively. At  $x = 0$  the phase angle relative to the incident shear wave is  $\delta_p$ . On the other hand the argument of the cosine and sine is constant along lines  $y - x \tan \phi' = \text{constant}$ ; these are lines inclined at an angle  $\phi'$  to the horizontal. Along such lines the perturbation velocity ( $w, w'$ ) remains constant in direction but attenuates exponentially with  $x$ ; the exponent is  $\frac{-\beta_w x y x}{\beta^2}$ .

For the case  $\bar{W} > 1$ , the velocity pattern associated with the pressure wave is much simpler (equations (38b)). The perturbation velocity vector ( $w, w'$ ) is constant along lines  $y - x \tan \phi' = \text{constant}$  and is, in fact, normal to such lines. In this case  $\phi' = (\phi - \text{Mach angle})$ , and these are just the Mach lines (or envelopes of the sound waves); they are inclined downward by the Mach angle  $\mu$  relative to the  $\xi$ -axis. It will be noted that the definitions of  $\phi'$ , the inclination angle of the lines of constant phase, agree at  $\bar{W} = 1$ , although expressed differently for  $\bar{W} < 1$  and for  $\bar{W} > 1$ .

The amplitude and phase of the  $w$  and  $w'$  components of the velocity in the pressure wave are compared with the amplitude of the initial shear wave in figure 9 for an initial Mach number of 1.5. The amplitude amplification ratios are  $\Pi$  and  $\beta_w \Pi$ , respectively;  $\Pi$ ,  $\beta_w \Pi$ , and a phase angle (lead)  $\delta_p$  are plotted in the curves against the initial wave inclination  $\theta$ . In the subsonic range ( $\bar{W} < 1$ )  $\Pi$  and  $\beta_w \Pi$  attenuate exponentially with  $x$  and only the values for  $x = 0$  are plotted. The phase lead varies from  $180^\circ$  to zero in this

subsonic range and remains zero throughout the supersonic range ( $\bar{W} > 1$ ). A rather striking feature is the relatively small perturbation velocity in the supersonic range. Thus, although the incident shear wave can give rise to a simple sound wave upon passing into the shock wave, the particle velocity in this sound wave amounts for most cases to 10 percent or less of the velocity in the initial shear wave for  $\bar{U}_A = 1.5$ .

### Pressure Field

It is shown in appendix B that the perturbation pressure is related to the velocity according to equation (B11); in the present notation this becomes

$$\left. \begin{aligned} \delta p &= -\rho W w_p \\ \text{or} \\ \frac{\delta p}{p} &= -\gamma \bar{W}^2 \frac{w_p}{W} \end{aligned} \right\} \quad (\text{B11}')$$

Here  $w_p$  is that component of the perturbation velocity associated with the pressure wave and directed parallel to  $W$  (that is, along the  $\xi$ -axis). Equation (B11') may be recognized as the linearized Bernoulli equation as limited to the velocity in the pressure wave.

Upon substituting for  $\bar{W}$  and  $W$  and using for  $w_p$  equations (38a) and (38b) with the S-terms omitted, there results

$$\frac{\delta p}{p} = -\frac{|w_A|}{U_A} \frac{2\gamma m \Pi \sec \phi}{(\gamma+1)m - (\gamma-1)} \cos \left[ \kappa_y (y - x \tan \phi') + \delta_p \right] \quad (39)$$

where  $\delta_p$  is to be taken as zero in the supersonic range of  $\bar{W}$ . This result for the perturbation pressure is proportional to  $\Pi \sec \phi$ ;  $\Pi$  has been plotted in figure 9, together with  $\delta_p$ , as a function of wave inclination  $\theta$  for  $\bar{W}_A = 1.5$ .

### Density Field

The density perturbation is related to the velocity and entropy perturbations according to equation (B12) of appendix B; in the present notation this is

$$\frac{\delta \rho}{\rho} = - \bar{W}^2 \frac{w_p}{W} - \frac{\delta s}{c_p} \quad (B12')$$

The term in  $w_p$  is the contribution of the pressure wave. This term differs from  $\delta p/p$  (equation (B11')) by a simple factor  $1/\gamma$ , so that the contribution is obtained at once from equation (39).

The term in  $\delta s$  is the contribution of the shear wave. The entropy perturbation  $\delta s$  has not been given explicitly before, but it can be obtained from equation (11a) by use of geometrical relations and the known result for  $\sigma$  (see following section). Upon evaluation, the term in  $\delta s$  is found to be

$$-\frac{\delta s}{c_p} = \frac{|w_A|}{U_A} \frac{2(m-1)^2 \cos \theta}{\frac{\gamma+1}{\gamma-1} m-1} \left[ (a \tan \theta - 1) \cos \kappa \eta + b \tan \theta \sin \kappa \eta \right] \quad (40)$$

#### Shock-Wave Perturbation

The local perturbation in the shock inclination angle may be written (cf. equation (8))

$$\sigma = \epsilon (a \cos \kappa_y y + b \sin \kappa_y y)$$

where  $a$  and  $b$  are evaluated in equation (29) for  $\bar{W} < 1$  and equation (34) for  $\bar{W} > 1$  ( $b = 0$  for  $\bar{W} > 1$ ).

The local shock deflection  $\delta x$  from the plane  $x = 0$  is obtained by integration of the slope  $\sigma$ :

$$\delta x = \int \sigma \, dy$$

The result may be put in the form

$$\delta x = |w_A| \frac{\lambda \sqrt{a^2 + b^2}}{2\pi U_A} \cos(\kappa_y y + \delta_{\text{shock}}) \quad (40)$$

where  $\delta_{\text{shock}} = \tan^{-1} \left( \frac{a}{b} \right)$  is the phase angle and  $\lambda = 2\pi/k$  is the wave length of the initial shear wave.

For a given wave length the factor  $\sqrt{a^2 + b^2}$  is proportional to the amplitude of this sinusoidal corrugation in the shock wave;

$\sqrt{a^2 + b^2}$  is plotted against the initial wave inclination  $\theta$  in figure 10. The phase angle  $\delta_{\text{shock}}$  is also plotted: the shock-wave corrugation is in phase with the initial shear wave ( $\delta_{\text{shock}} = 0$ ) when the initial wave is horizontal ( $\theta = 0$ ). The shock corrugation progressively lags the initial shear wave as  $\theta$  is increased until the sonic condition  $\bar{M} = 1$  is reached; at this point the lag is  $90^\circ$ , and this value is maintained throughout the range  $\bar{M} > 1$  as  $\theta$  is increased to  $90^\circ$  (vertical initial shear wave). At  $\theta = 90^\circ$  the amplitude factor  $\sqrt{a^2 + b^2}$  has fallen to zero: a vertical sinusoidal shear wave passing by convection through a vertical shock wave causes no perturbation of the shock form or position.

### Intensity of Sound Field

The acoustic intensity of the noise or sound field generated by the interaction of the shock wave and the turbulence has been found to be relatively high.<sup>1</sup> It will suffice for an order-of-magnitude estimate to replace the turbulent field by a single plane wave, or Fourier component, with the same kinetic-energy density. Roughly this implies that the root-mean-square turbulent velocity is to be identified with  $0.707 |w_A|$ .

The sound pressure is proportional to  $\Pi \sec \phi$ , where  $\Pi$  is plotted in figure 9. The relatively high values indicated for the subsonic range attenuate rapidly with distance  $x$  downstream of the shock; when  $x$  appreciably exceeds several wave lengths the values are negligible compared with those in the supersonic range. A rough average over all wave inclinations  $\theta$ , assuming the subsonic range contributes nothing, gives  $|\Pi \sec \phi| \cong 0.082$ ; this value will be used in the noise estimate.

The noise level in decibels relative to the standard reference level  $\delta p_0 = 2.015 \times 10^{-10}$  atmospheres at standard density  $\rho_0$  and speed of sound  $a_0$  is given by

---

<sup>1</sup>A high acoustic intensity does not imply a large fractional pressure perturbation in relation to ambient pressure: the sensitivity of the ear is so great that extremely small pressure perturbations correspond to very loud noises.

$$\begin{aligned}
 db &= 20 \log \frac{\delta p}{\delta p_o} + 10 \log \frac{\rho_o a_o}{\rho a} \\
 &= 20 \log \left( \frac{\delta p}{p} \frac{p}{\delta p_o} \right) + 10 \log \frac{\rho_o a_o}{\rho a} \quad (41)
 \end{aligned}$$

where the  $\delta p$ 's are root-mean-square values. By equation (39)

$$\frac{\delta p_{\text{rms}}}{p} = \frac{|w_A|}{U_A} \frac{\sqrt{2} \gamma m}{(\gamma + 1)^m - (\gamma - 1)} \overline{|\Pi \sec \phi|} \quad (42)$$

As an example the noise level generated by the turbulence passing through a normal shock in a representative supersonic wind tunnel will be estimated. A root-mean-square velocity of turbulence of 1 foot per second is assumed to exist in the test section where the mean speed is 1400 feet per second and the Mach number is 1.5 ( $\bar{U}_A = 1.5$ ).

Thus  $0.707 |w_A|$  and  $U_A$  are taken to be 1 and 1400 feet per second, respectively. A summary of these and the remaining parameters of the example is

$$\overline{|\Pi \sec \phi|} = 0.082$$

$$0.707 |w_A| = 1 \text{ foot per second}$$

$$U_A = 1400 \text{ feet per second}$$

$$m = 1.862 (\sim \bar{U}_A = 1.5)$$

$$\gamma = 1.4$$

$$p = 0.272 \text{ atmosphere } (\sim 1 \text{ atm. reservoir pressure})$$

$$\delta p_o = 2.015 \times 10^{-10} \text{ atmospheres}$$

$$\frac{\rho_o a_o}{\rho a} = 1.425$$

The estimate based on equation (42) gives a pressure perturbation  $\delta p_{\text{rms}}/p = 7.50 \times 10^{-5}$ , and by equation (41) the corresponding sound intensity is 102 decibels. This represents very intense noise, reaching a level which can damage the ear on continued exposure (reference 7). This noise estimate is thought to be conservative, corresponding to a supersonic wind tunnel with a relatively low level of turbulence. It appears probable that many tunnels will considerably exceed this level.

### Generalization to Oblique Shocks

The analysis refers to flow through a normal shock, but the results are easily generalized for oblique shocks. In the oblique-shock case the component of the upstream velocity normal to the shock plays the role of  $U_A$ ; the component parallel to the shock is ignored in formulating the equivalent steady-flow problem. A formal approach is to retain the present definitions wherein  $U_A$  is the actual upstream velocity (taken horizontal) and  $\theta$  and  $\phi$  are referred to the horizontal; the oblique shock is assumed inclined by some angle  $\alpha$  measured clockwise from the vertical. Then the present formulas will be generalized to apply to the oblique shock if the following transformations are made:

$$U_A \rightarrow U_A \cos \alpha$$

$$\theta \rightarrow \theta + \alpha$$

$$\phi \rightarrow \phi + \alpha$$

### Related Problems

The sound field produced downstream by the convection of turbulence through a shock has been discussed. Also of interest are sound fields incident upon a shock in the absence of turbulence. The elementary sound disturbance is the plane sinusoidal wave: a longitudinal wave. The passage of such a wave through a shock, which is an unsteady-flow problem, can again be converted to an equivalent steady-flow problem by transformation to a reference frame moving with a suitable velocity parallel to the shock front; in this frame the sound-wave pattern will appear as a stationary Mach wave pattern. A diagrammatic construction is shown in figure 11. Note that either of two sound patterns of uniquely related inclinations may be rendered stationary by a given choice of  $V$ ; the two patterns may be identified with the two families of Mach waves in a stream of supersonic velocity  $W_A$ .

The equations for the boundary conditions at the shock and the vorticity behind the shock will be modified from those for the present case of the shear wave, but the general character of the solution will be unchanged. Thus, a shear wave as well as a sound wave will appear downstream of the shock. The discussion will be carried no further here: the solution has been obtained in the unpublished investigation of F. K. Moore by his unsteady-flow method.

The interaction of a sinusoidal Mach wave pattern with a normal shock constitutes a simple special case: here the velocity  $V$  of the

moving reference frame may be taken to be zero. This problem has been solved in general terms by Adams (reference 5); he limited his discussion, however, to the vicinity immediately downstream of the shock. The character of the flow further downstream can be inferred from the parallel that exists between this problem and the problem herein of the horizontal shear wave: in both cases  $V$  is zero. The asymptotic flow far downstream is therefore a horizontal sinusoidal shear wave. Near the shock the wave is modified by transverse and axial components (with associated pressure perturbations) which attenuate exponentially with distance downstream of the shock (cf. fig. 5).

According to these considerations, sinusoidal corrugations in a wind-tunnel wall, or a plate, upstream of a plane shock wave will generate a horizontal sinusoidal shear flow. Such a shear flow might have applications in special experimental work.

#### CONCLUDING REMARKS

The effects produced by the convection of an inclined plane sinusoidal shear wave through a normal shock have been analyzed. Such a wave may be interpreted as a single spectrum component of a turbulent field; that is, the turbulent field can be represented as a superposition of such shear waves of all orientations and wave lengths (Fourier integral).

When the turbulence is convected through a shock, the individual waves do not mutually interfere if, as specified herein, the intensity is sufficiently low; thus the modified field downstream of the shock can be obtained in principle by superposition of the modified individual waves. In practice the initial wave distribution is known only statistically, and statistical changes only can be calculated. In either case the present analysis of the behavior of a representative individual wave constitutes a prerequisite to the determination of the changes in the weak turbulent field.

It is found that a sinusoidal shear wave of arbitrary inclination as it passes into the shock gives rise downstream to a shear wave of altered inclination and altered amplitude. In addition, there is generated a "pressure wave": an additional velocity field with associated pressure disturbances that can be recognized as sound waves.

The analysis is made in a frame of reference moving with a certain velocity  $W$  referred to axes at rest relative to the general mass of fluid downstream of the shock;  $W$  is the vector sum of the reversed downstream velocity and the cross-stream speed of the ripple pattern in the shock wave. The results depend crucially on whether  $W$  is

subsonic or supersonic: when  $W$  is subsonic both the shear wave and pressure wave are shifted in phase relative to the initial shear wave, and the pressure wave shows an exponential attenuation downstream of the shock; when  $W$  is supersonic there are no phase shifts, and the pressure wave takes the form of a plane, undamped, sinusoidal sound wave.

A weak initial shear wave is found to produce a surprisingly intense pressure wave or sound field downstream of the shock, as measured in acoustic terms. This implies that the convection of relatively low-intensity turbulence through a shock will generate a very intense noise field in the downstream region. In an example the noise level generated by turbulence in a representative supersonic wind tunnel was estimated to be of the order of 100 decibels.

Lewis Flight Propulsion Laboratory  
National Advisory Committee for Aeronautics  
Cleveland, Ohio, September 26, 1952

## APPENDIX A

## SYMBOLS

A	function defined in equation (23)
a	parameter in shock-wave perturbation (equation (8)); also speed of sound
B	function defined in equation (23)
b	parameter in shock-wave perturbation (equation (8))
C	function defined in equation (30)
C'	function defined in equation (35)
c	parameter $\left( \begin{array}{ll} = c' \beta_w \cos \phi & \text{for } \bar{W} > 1 \\ = c' \alpha \beta_w \cos \phi & \text{for } \bar{W} < 1 \end{array} \right)$
c'	constant of integration
c''	constant of integration
c <sub>p</sub>	specific heat at constant pressure
D	function defined in equation (30)
D'	function defined in equation (35)
d	parameter $(= d' \alpha \beta_w \cos \phi)$
d'	constant of integration
E	function defined in equation (30)
E'	function defined in equation (35)
F	function defined in equation (30)
F'	function defined in equation (35)
G	function defined in equation (35)
H	stagnation enthalpy (per unit mass)
k	wave number of shear wave in region A (incident shear wave)

M	Mach number ( $U/a$ , appendix B)
m	velocity ratio across normal shock ( $U_A/U$ )
p	pressure
S	relative amplitude of refracted shear wave (see equations (38a) and (38b))
s	entropy (per unit mass)
T	temperature (absolute)
t	time
U,V	stream velocity components in x- and y-directions (fig. 3) (equivalent steady-flow problem)
$\bar{U}$	Mach number associated with U ( $U/a$ )
u,v	perturbation velocity components in x- and y-directions, respectively, (fig. 3)
W	stream velocity in $\xi$ -direction (resultant of U and V) (equivalent steady-flow problem)
$\bar{W}$	Mach number associated with W ( $W/a$ )
w,w'	perturbation velocity components in $\xi$ - and $\eta$ -directions, respectively (fig. 3)
w <sub>p</sub>	that part of w associated with pressure wave
x,y	rectangular coordinates (fig. 3)
$\beta =$	$\sqrt{1 - \bar{U}^2}$
$\beta_w =$	$\begin{cases} \sqrt{1 - \bar{W}^2} & \bar{W} < 1 \\ \sqrt{\bar{W}^2 - 1} & \bar{W} > 1 \end{cases}$
$\gamma$	ratio of specific heats
$\delta_p$	phase lead of pressure wave relative to incident shear wave
$\delta_s$	phase lead of refracted shear wave relative to incident shear wave

$\epsilon$	measure of strength of incident shear wave ( $w_A/w_A$ )
$\theta$	inclination of lines of constant phase in incident shear wave (figs. 1, 2, 3, and 4)
$\theta_{cr}$	critical value of $\theta$ for which $\bar{W} = 1$ (function of $\bar{U}_A$ )
$\kappa$	wave number of refracted shear wave
$\mu$	Mach angle associated with $\bar{W}$ ( $\sin^{-1}(1/\bar{W})$ )
$\xi, \eta$	inclined rectangular coordinates (fig. 3)
$\Pi$	relative amplitude of velocity component $w$ in pressure wave (see equations (38a) and (38b))
$\rho$	fluid density
$\sigma$	perturbation in local shock angle (fig. 4)
$\phi$	inclination of lines of constant phase in refracted shear wave
$\phi'$	inclination of lines of constant phase in pressure wave
$\psi$	perturbation stream function
$\psi_C$	complementary function (component of $\psi$ )
$\psi_P$	particular integral (component of $\psi$ )
$\Omega$	vorticity ( $v_x - u_y$ )

## Subscripts:

A	region A (upstream of shock)
o	evaluated at shock, on downstream side
$x, y, \xi, \eta$	indicate the corresponding partial derivatives (e.g., $v_x = \frac{\partial v}{\partial x}$ ); an exception is $\kappa_y = \kappa \cos \phi = k \cos \theta$
	(Unsubscripted velocity components, pressure, and density refer to region downstream of shock.)

## Prefix

$\delta( )$	increment in ( )
-------------	------------------

## APPENDIX B

## LINEAR PERTURBATION THEORY FOR ROTATIONAL FLOW

The generalized governing equation for the stream function can be obtained by extending Sears' constant-energy development (reference 4) to include the effects of variation of energy (total enthalpy). A different approach is, however, employed herein. Equations for the pressure and density fields are also obtained.

In applying the results of this appendix to the developments in the main text it is to be noted that the x- and y-axes herein will go over, respectively, into the  $\xi$ - and  $\eta$ -axes therein; this is a consequence of the difference in direction of the main stream in the two cases. There is a corresponding change in the notation for the velocity components.

## Governing Equation

Basic equations. - Consider the steady two-dimensional adiabatic flow of an inviscid fluid with local velocity  $u', v'$ , pressure  $p$ , density  $\rho$ , temperature  $T$ , and entropy  $s$ . Assume only small perturbations from a uniform horizontal flow such that  $u' = U + u$ ,  $v' = v$ , with  $u/U$ ,  $v/U \ll 1$ , and also  $\delta p/p$ ,  $\delta \rho/\rho$ , etc.  $\ll 1$ . Then the basic flow equations may be linearized by neglecting quantities of order  $u/U$ , and so forth, in comparison with unity. A convenient form of these linearized equations is

$$\text{Continuity: } u_x + v_y + \frac{1}{\rho} \frac{D\rho}{Dt} = 0 \quad (\text{B1})$$

$$\text{State: } \frac{\delta \rho}{\rho} = \frac{\delta p}{\rho a^2} - \frac{\delta s}{c_p} \quad (\text{B2})$$

$$\text{Energy: } \frac{Ds}{Dt} = 0 \quad (\text{B3})$$

$$\text{Momentum: } \left. \begin{aligned} -p_x &= \rho U u_x \\ -p_y &= \rho U v_x \end{aligned} \right\} \quad (\text{B4})$$

where  $D/Dt$  signifies the Lagrangian operator for differentiation following the fluid motion.

Elimination of density from continuity equation. - The Lagrangian form of the state equation is, by virtue of the energy equation,

$$\begin{aligned}\frac{1}{\rho} \frac{D\rho}{Dt} &= \frac{1}{\rho a^2} \frac{Dp}{Dt} \\ &= \frac{1}{\rho a^2} \left[ (U + u)p_x + vp_y \right]\end{aligned}$$

Upon linearizing, assuming  $p_y$  and  $p_x$  to be of comparable magnitude, this is

$$\frac{1}{\rho} \frac{D\rho}{Dt} = \frac{Up_x}{\rho a^2}$$

and by use of the first momentum equation

$$\frac{1}{\rho} \frac{D\rho}{Dt} = -M^2 u_x$$

The linearized continuity equation (B1) may accordingly be written

$$(1 - M^2)u_x + v_y = 0 \quad (B5)$$

Formulation of governing equation. - Define a stream function  $\psi$  such that

$$\begin{aligned}u &= \psi_y \\ v &= - (1 - M^2)\psi_x\end{aligned} \quad (B6)$$

Then equation (B5) is identically satisfied by  $u$  and  $v$  as defined in equation (B6). The governing equation for  $\psi$  is now obtained by expressing the vorticity  $v_x - u_y \equiv \Omega$  in terms of  $\psi$ :

$$(1 - M^2)\psi_{xx} + \psi_{yy} = -\Omega \quad (B7)$$

A useful expression of the vorticity in terms of gradients of entropy and total enthalpy is given in reference 8, equation (8.3), as

$$-\Omega = \frac{1}{q} \left( \frac{\partial H}{\partial n} - T \frac{\partial s}{\partial n} \right)$$

where  $q$  is the resultant velocity and  $\partial/\partial n$  indicates differentiation normal to a streamline. In the small-perturbation flow the streamlines are approximated by the lines  $y = \text{constant}$ , so that  $\partial/\partial n \approx \partial/\partial y$ ; also  $q \approx U$ . Thus

$$-\Omega = \frac{1}{U} \left( \frac{\partial H}{\partial y} - T \frac{\partial s}{\partial y} \right)$$

The governing equation for  $\psi$ , equation (B7), can now be amplified to read

$$(1 - M^2)\psi_{xx} + \psi_{yy} = -\Omega = \frac{H_y - Ts_y}{U} \quad (B8)$$

This equation and its companion

$$\begin{aligned} u &= \psi_y \\ v &= -(1 - M^2)\psi_x \end{aligned} \quad (B6)$$

constitute the simplified generalization of Sears' governing equation for linearized rotational flow (reference 4, equations (12) and (15)); Sears' equation is restricted to flows of constant total enthalpy  $H$ .

Equation (B8) exhibits the following very interesting property: In the small-perturbation velocity field considered here the effect of the rotation or vorticity  $\Omega$  is independent of how it arises, whether from a gradient of entropy or a gradient of total enthalpy, or a combination of both. And it is only through their contribution to  $\Omega$  (and perhaps to the boundary conditions) that variations in entropy and total enthalpy affect the velocity field at all.

#### Pressure Field

Equations relating the pressure distribution to the velocity distribution will now be derived: The momentum equations (B4) may be rewritten in the form:

$$\left. \begin{aligned} \frac{p_x}{\rho} + Uu_x &= 0 \\ \frac{p_y}{\rho} + Uu_y &= -U\Omega \end{aligned} \right\} \quad (B9)$$

since  $\Omega = v_x - u_y$ .

Now let consideration be limited to special types of flow such that

$$\left. \begin{aligned} u &= u' + u'' \\ v &= v' \end{aligned} \right\} \quad (B10)$$

where  $u', v'$  is an irrotational flow ( $v'_x - u'_y = 0$ ) and  $u'' = u''(y)$  is a pure shear flow parallel to  $x$  ( $v'' = 0$ )<sup>1</sup>. Then the vorticity  $\Omega$  is given by

$$\Omega = v'_x - u'_y = -u''_y$$

and

$$u''_x = 0$$

Thus equations (B9) become

$$\frac{p_x}{\rho} + Uu'_x = 0$$

$$\frac{p_y}{\rho} + Uu'_y = 0$$

These two equations are equivalent to

$$\frac{\delta p}{\rho} + Uu' = 0 \quad (B11)$$

which is just the linearized Bernoulli equation in terms  $u'$  alone.

The physical interpretation is this: If the assumed total perturbation consists of a plane shear flow  $(u'', 0)$  and a potential flow  $(u', v')$ , then there is no pressure perturbation associated with the shear flow; the entire pressure perturbation arises from the potential flow and is related to  $u'$  by the ordinary linearized Bernoulli equation. In other words, the pressure is obtained by subtracting out the shear-flow velocity and applying the linearized Bernoulli equation to the remaining velocity.

#### Density Field

The density distribution can be related to the velocity and entropy distributions as follows: The starting point is the differential equation of state (B2)

$$\frac{\delta \rho}{\rho} = \frac{\delta p}{\rho a^2} - \frac{\delta s}{c_p}$$

---

<sup>1</sup>Since  $H$  and  $s$  are constant along streamlines (reference 8), this approximates the general small-perturbation flow to the extent that the lines  $y = \text{constant}$  approximate streamlines.

Again assume that the flow is a combined potential flow  $(u', v')$  and shear flow  $(u'', 0)$ .<sup>1</sup> (See equation (B10) and after.) Then equation (B11) applies for  $\delta p/\rho$ , and the density field is given by

$$\frac{\delta \rho}{\rho} = - \frac{U u'}{a^2} - \frac{\delta s}{c_p}$$

or

$$\frac{\delta \rho}{\rho} = - M^2 \frac{u'}{U} - \frac{\delta s}{c_p} \quad (\text{B12})$$

Thus it is found that the density perturbation depends on the potential flow via the velocity perturbation  $u'$  and on the shear flow via the entropy perturbation  $\delta s$ .

---

<sup>1</sup>Since  $H$  and  $s$  are constant along streamlines (reference 8), this approximates the general small-perturbation flow to the extent that the lines  $y = \text{constant}$  approximate streamlines.

## APPENDIX C

## VARIANTS OF THE SHOCK RELATIONS

The ratio of the normal velocities before and after the shock has been defined as  $m$ .

$$m = U_A/U \quad (C1)$$

Thus by reference 6, equation (114),

$$m = \frac{\frac{\gamma + 1}{2} \bar{U}_A^2}{1 + \frac{\gamma - 1}{2} \bar{U}_A^2} \quad (C2)$$

where  $\bar{U}_A$  is the normal Mach number ahead of the shock. Correspondingly,  $\bar{U}$  is the normal Mach number behind the shock, and by reference 6, equation (112),

$$\bar{U}^2 = \frac{1 + \frac{\gamma - 1}{2} \bar{U}_A^2}{\gamma \bar{U}_A^2 - \frac{\gamma - 1}{2}} \quad (C3)$$

From equations (C2) and (C3) it can be shown that

$$\frac{\bar{U}^2}{\beta^2} = \frac{2}{(\gamma + 1)(m - 1)} \quad (C4)$$

and

$$\frac{\bar{U}_A^2 - 1}{1 + \frac{\gamma - 1}{2} \bar{U}_A^2} = m - 1 \quad (C5)$$

where

$$\beta^2 \equiv 1 - \bar{U}^2$$

The equality of transverse velocity components across an oblique-shock wave requires, in the present notation, that

$$U_A \tan \theta = U \tan \phi$$

Then, with the definition (C1),

$$m \tan \theta = \tan \phi \quad (C6)$$

Equations (C2) and (C6) together allow  $\phi$  to be determined in terms of  $\theta$  and  $\bar{U}_A$ .

#### REFERENCES

1. Taylor, G. I., and Batchelor, G. K.: The Effect of Wire Gauze on Small Disturbances in a Uniform Stream. *Quart. Jour. Mech. Appl. Math.*, vol. II, 1949, pp. 1-29.
2. Ribner, H. S., and Tucker, M.: Spectrum of Turbulence in a Contracting Stream. NACA TN 2606, 1952.
3. Kovásznay, Leslie S. G.: Hot-Wire Anemometer in Supersonic Flow. *Jour. Aero. Sci.*, vol. 17, no. 9, Sept. 1950, pp. 565-572, 584.
4. Sears, W. R.: The Linear-Perturbation Theory for Rotational Flow. *Jour. Math. and Phys.*, vol. 28, no. 4, Jan. 1950, pp. 268-271.
5. Adams, Mac C.: On Shock Waves in Inhomogeneous Flow. *Jour. Aero. Sci.*, vol. 16, no. 11, Nov. 1949, pp. 685-690.
6. The Staff of the Ames 1- by 3-Foot Supersonic Wind-Tunnel Section: Notes and Tables for Use in the Analysis of Supersonic Flow. NACA TN 1428, 1947.
7. Parrack, Horace O., and Eldredge, Donald H.: Noise Problems Associated with Aircraft Maintenance. *Tech. Data Digest (CADO)*, vol. 16, no. 7, July 1951, pp. 22-25.
8. Vazsonyi, Andrew: On Rotational Gas Flows. *Quart. Appl. Math.*, vol. III, no. 1, April 1945, pp. 29-37.

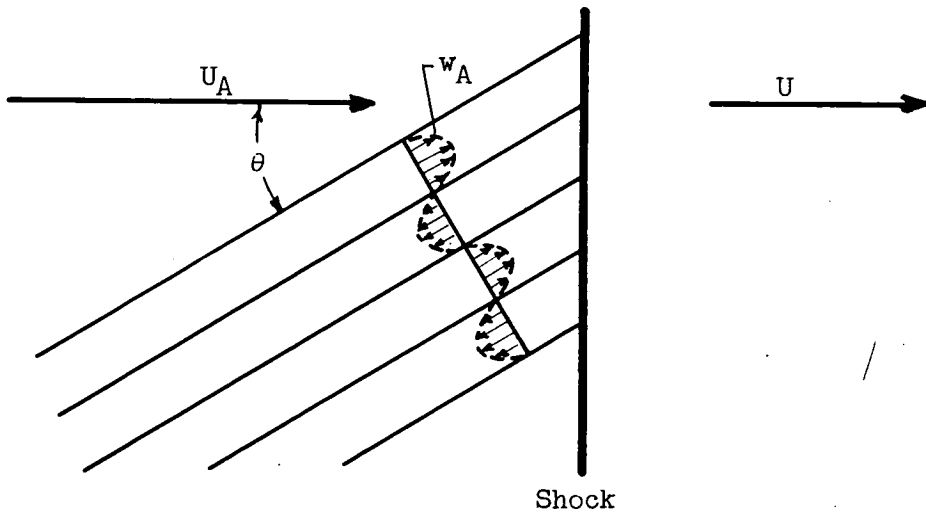

Figure 1. - Convection of plane oblique sinusoidal shear wave through shock: original unsteady-flow problem.

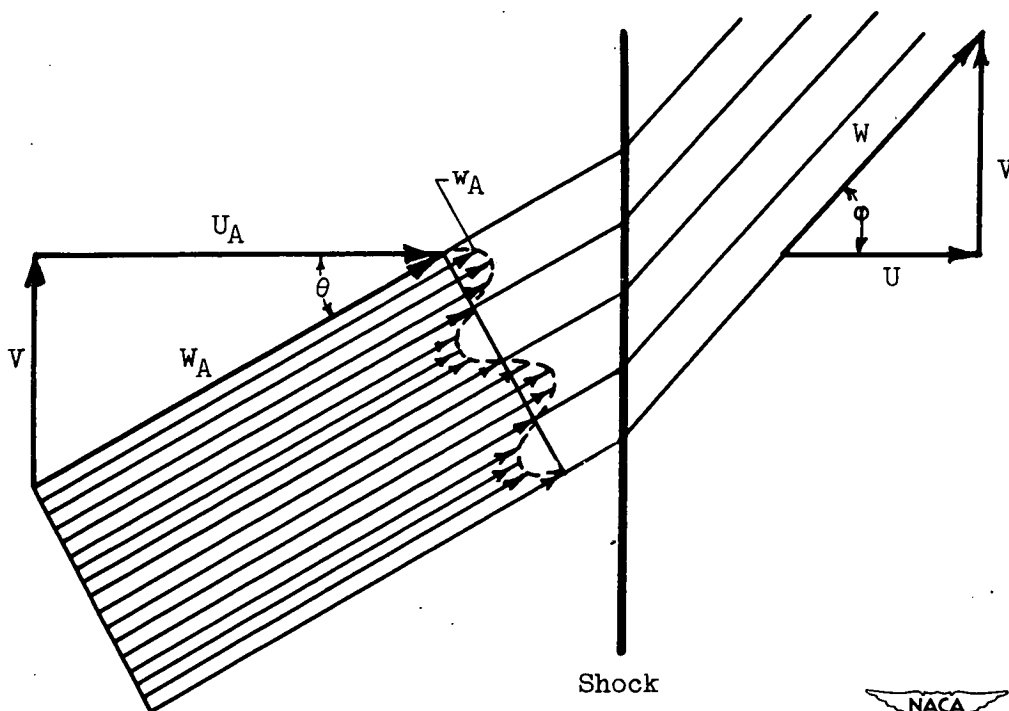

Figure 2. - Transformation to equivalent steady-flow problem by superposition of velocity  $V$ .



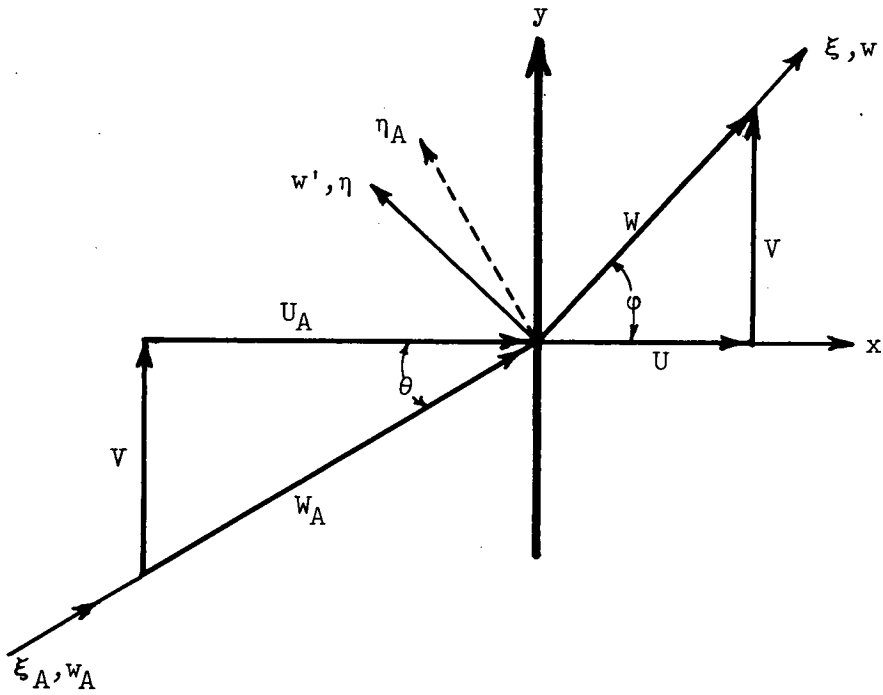

Figure 3. - Symbols and coordinate axes.

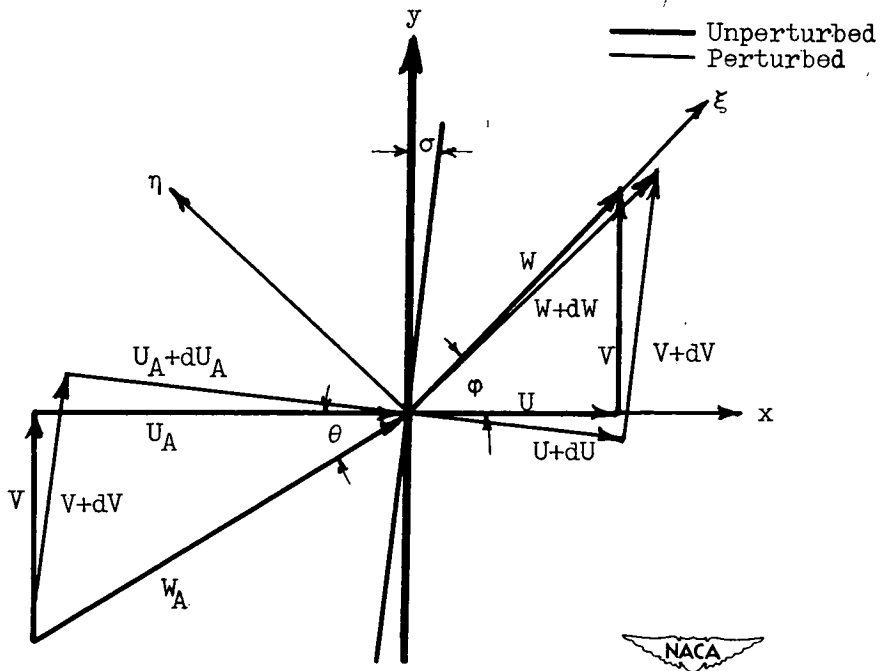

Figure 4. - Geometrical relations across shock, with and without perturbation  $\sigma$  in shock angle.

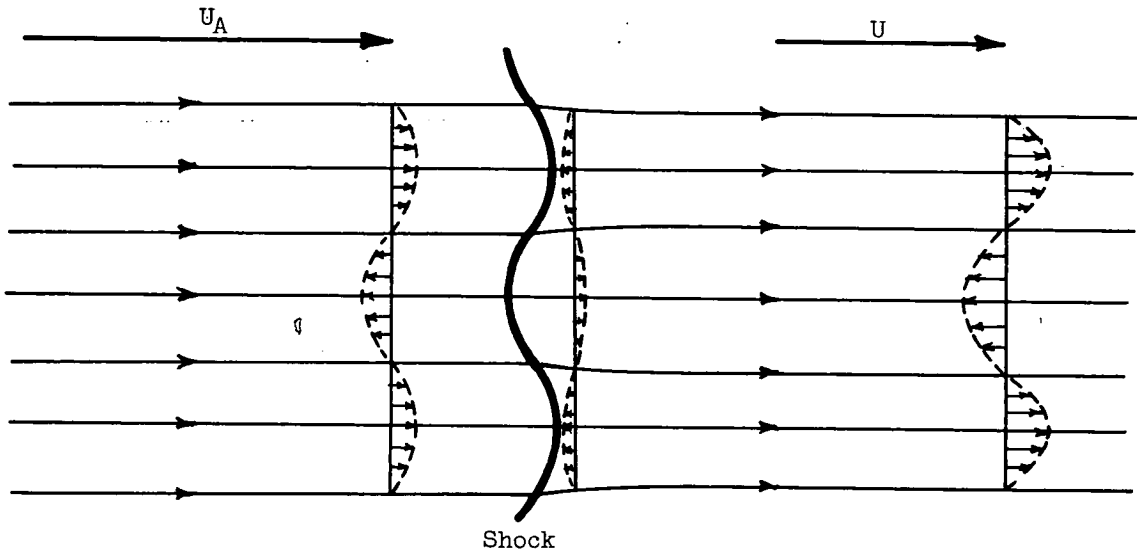

Figure 5. - Passage of horizontal shear wave through normal shock, showing perturbation of shock and final amplification of shear wave.

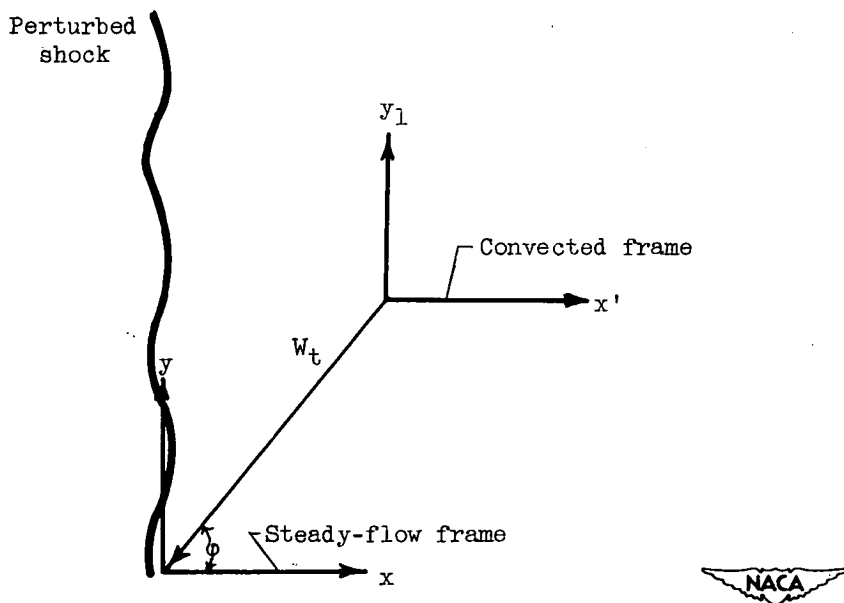

Figure 6. - Relative motion of reference frame moving with general downstream flow (convected frame) and reference frame of analysis (steady-flow frame). The steady-flow frame moves downward along the shock front with a component velocity  $V$  and carries the ripple pattern with it.

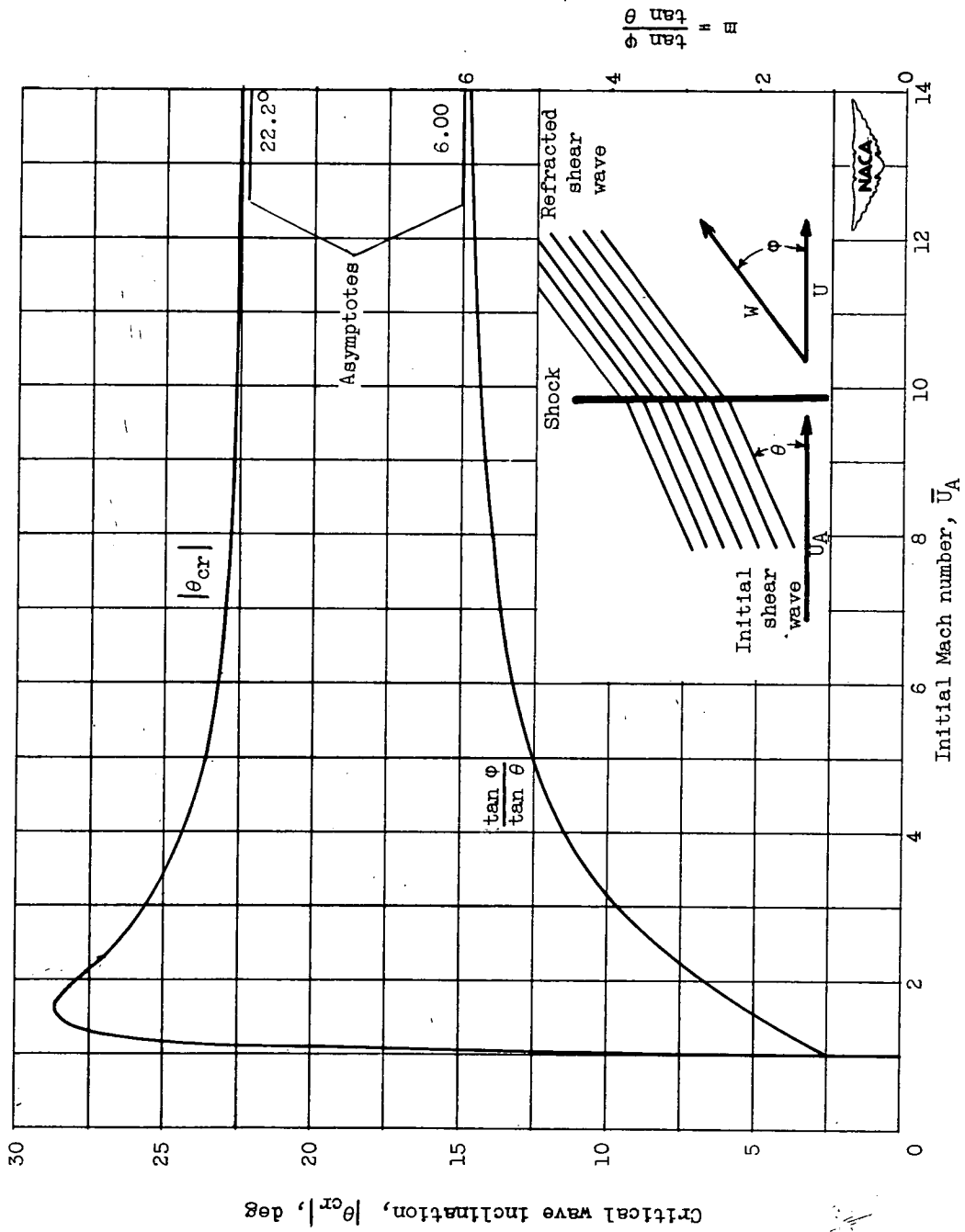

Figure 7. - Upper curve shows variation with initial Mach number of critical wave inclination for which  $W$  is sonic. Lower curve shows variation of  $m \equiv U_A/U = \tan \phi / \tan \theta$  with initial Mach number.

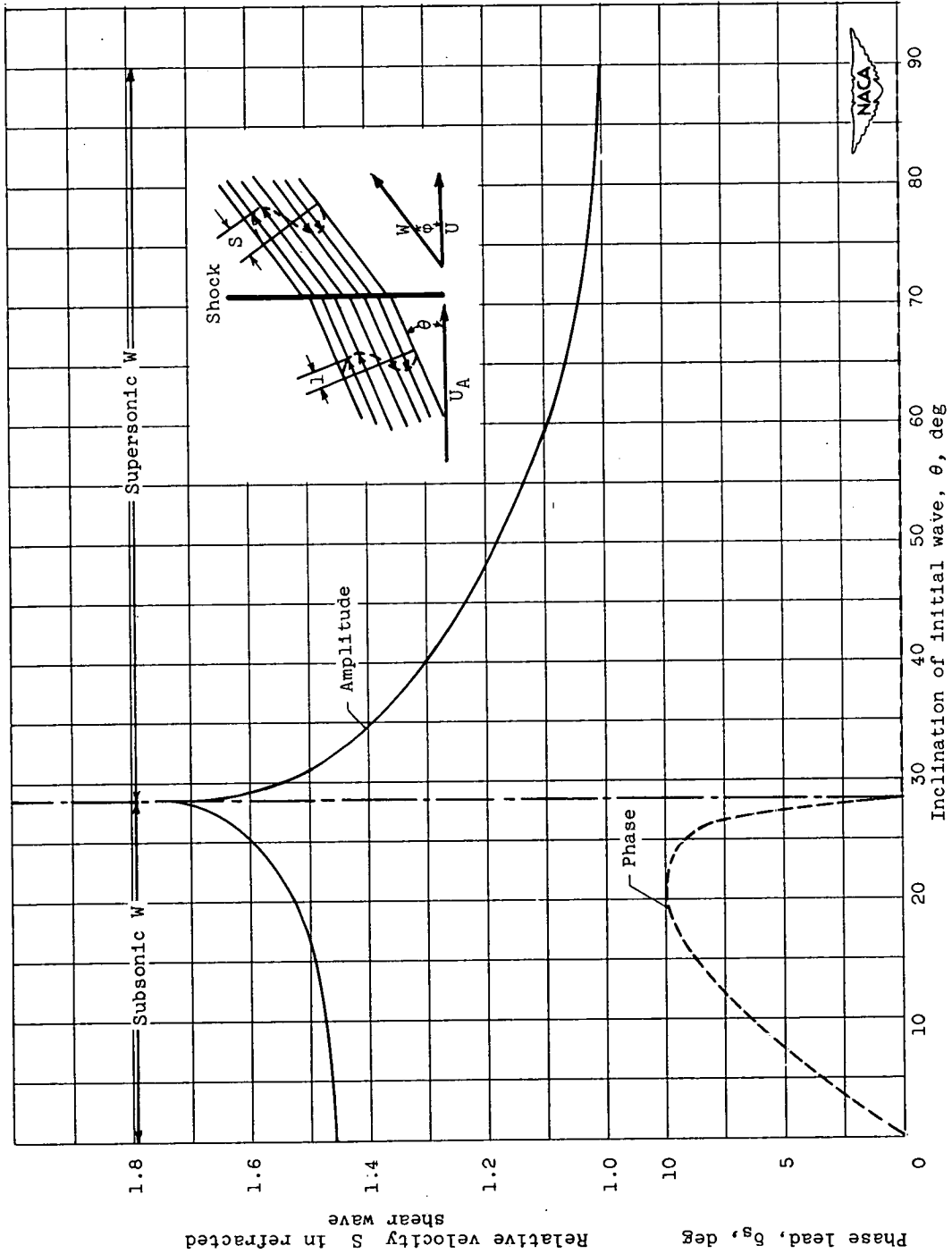

Figure 8. - Amplification and phase shift of velocity in shear wave on passage through shock. Initial Mach number  $\bar{U}_A$ , 1.5.

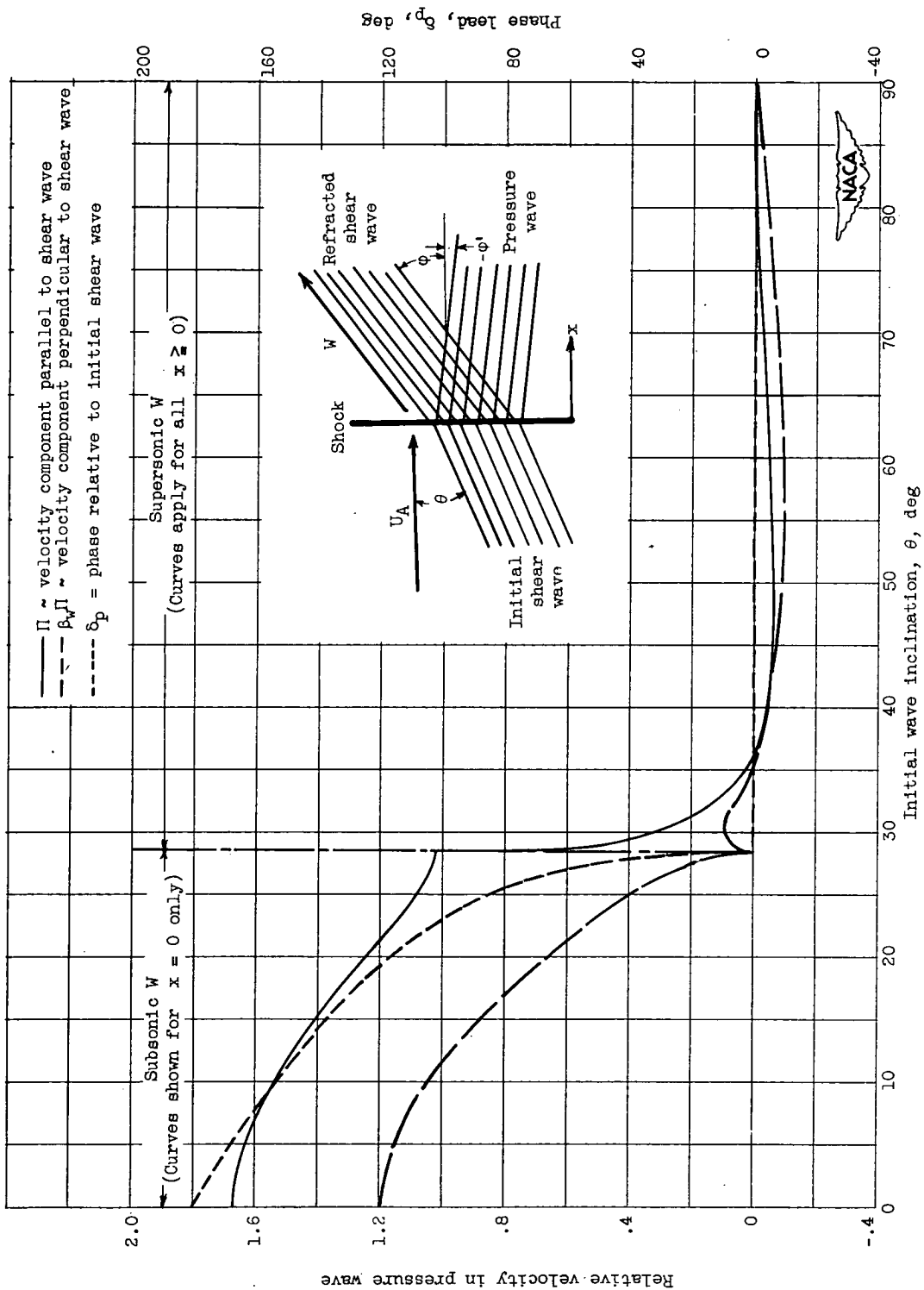

Figure 9. - Amplitude and phase of velocity components in pressure wave generated by passage of shear wave through shock. Initial Mach number  $\bar{U}_A$ , 1.5. Parallel lines in inset figure are lines of constant phase.

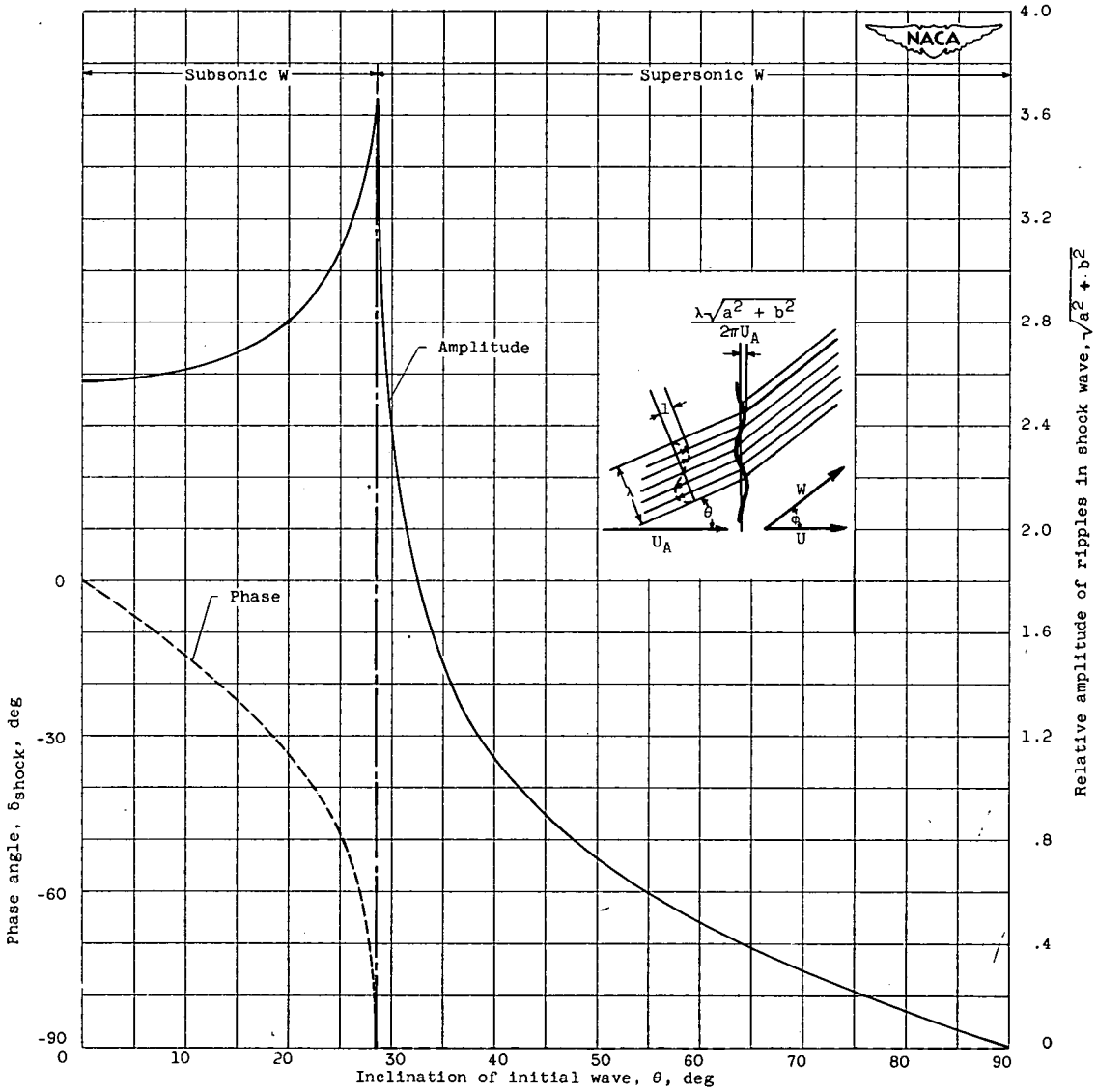

Figure 10. - Amplitude and phase of ripples developed in shock by passage of shear wave. Initial Mach number  $U_A$ , 1.5.

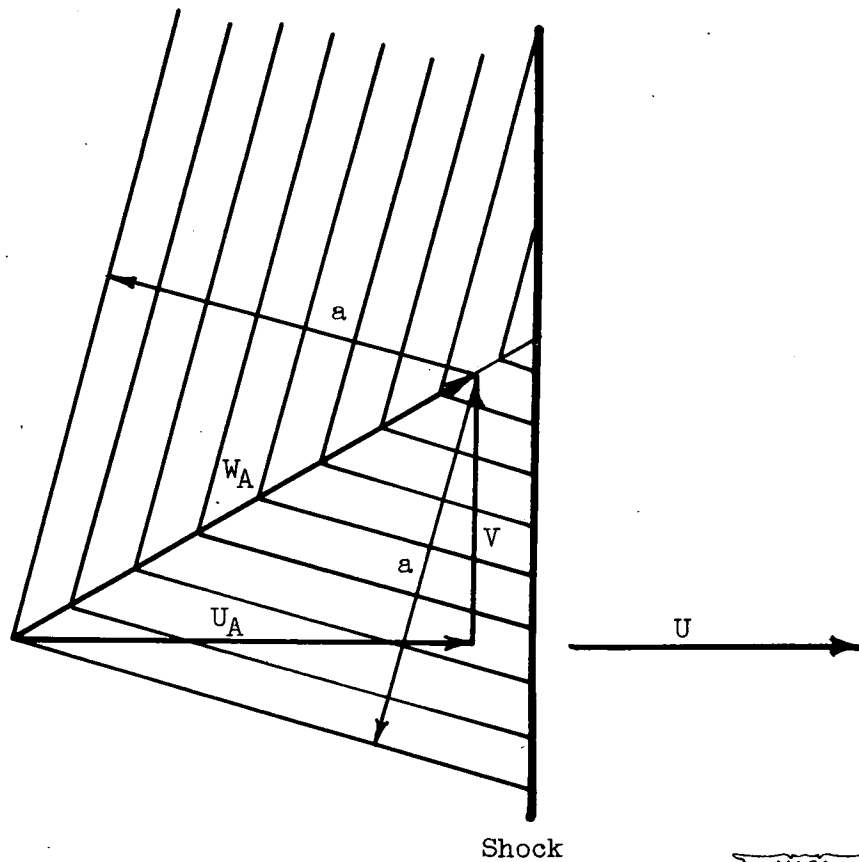

Figure 11. - Construction for translation  $V$  to render either of two sound-wave patterns stationary in a main stream  $U_A$ .

