

TN-2948

NATIONAL ADVISORY COMMITTEE FOR AERONAUTICS

TECHNICAL NOTE 2948

INVESTIGATION OF LATERAL CONTROL NEAR THE STALL
FLIGHT INVESTIGATION WITH A LIGHT HIGH-WING MONOPLANE
TESTED WITH VARIOUS AMOUNTS OF WASHOUT AND
VARIOUS LENGTHS OF LEADING-EDGE SLOT

By Fred E. Weick, Maurice S. Sevelson,
James G. McClure, and Marion D. Flanagan

Agricultural and Mechanical College of Texas

TECHNICAL LIBRARY
AIRE RESEARCH MANUFACTURING CO.
9851-9951 SEPULVEDA BLVD.
LOS ANGELES 45, CALIF.
CALIFORNIA



Washington

May 1953



NATIONAL ADVISORY COMMITTEE FOR AERONAUTICS

TECHNICAL NOTE 2948

INVESTIGATION OF LATERAL CONTROL NEAR THE STALL

FLIGHT INVESTIGATION WITH A LIGHT HIGH-WING MONOPLANE

TESTED WITH VARIOUS AMOUNTS OF WASHOUT AND

VARIOUS LENGTHS OF LEADING-EDGE SLOT

By Fred E. Weick, Maurice S. Sevelson,
James G. McClure, and Marion D. Flanagan

SUMMARY

Flight tests were made with a typical light airplane to investigate possibilities for obtaining reliable control at low flight speeds. It was found that satisfactory lateral control occurred consistently, even under conditions simulating extremely gusty air, at angles of attack approximately 2° below that for the maximum lift coefficient (or the stall of the wing as a whole). This 2° margin was substantially the same both with full power and with the engine throttled and throughout the range of center-of-gravity locations tested. Supplementary tests were then made on the control at high angles of attack under actual gusty air conditions, on the possibility of entering spins, and on the amount of elevator control required for normal three-point landings. It was found that with the original plain untwisted wing obtaining the constant 2° margin below the stall required widely different elevator deflections for the range of power and center-of-gravity locations tested. Also, none of these settings was high enough to produce a three-point landing.

An attempt was then made to find a configuration that would provide sufficient elevator control for a three-point landing under the most critical condition (forward center of gravity) and that at the same time would have insufficient elevator control to exceed the angle of attack at which reliable lateral control is obtained in flight under all of the center-of-gravity and power conditions. The entire series of tests was repeated with the wing twisted to 4° and to 8° of washout and with five different lengths of leading-edge slots covering the outer 30, 50, 60, 70, and 90 percent of the wing span. With 8° of washout the aileron control itself was satisfactory under all conditions tested, even at angles of attack well beyond that for the airplane maximum lift coefficient. Longitudinal fluctuations occurred, however, at all angles of

attack above that for the initial stalling of the center of the wing. The results for the 30-percent slots were the same as those without slots. With all of the other slot configurations lateral control was maintained at high angles of attack, but severe longitudinal fluctuations occurred at angles of attack above that for the stall of the plain wing.

It was determined that the longitudinal fluctuations were caused by burbling over the upper surface of the wing at the center where it is also the upper surface of the fuselage. The fluctuations were eliminated by the use of a full-span slot. The slot was extended over the fuselage and modified in cross section to adapt it to the fuselage contour. With the full-span slot the angle for maximum lift coefficient was increased 6° .

The desired condition, that is, having sufficient up-elevator control to accomplish three-point landings but insufficient to exceed the angle of attack for satisfactory lateral control, was attained under limited conditions with both the case of the 8° of washout and the case of the full-span slot. In both cases the desired condition was attained only with power off and with the center of gravity forward.

INTRODUCTION

Severe lateral instability at the stall presents a serious hazard to the private flyer. Although much progress has been made in improving the safety of personal aircraft, the accident reports indicate that far too many fatal accidents still result from stalls, spins, and lack of control near the stall. Records show that, previous to 1929 (ref. 1), over two-thirds of the accidents were from causes associated with spins, stalls, or landings. More recent records, the Civil Aeronautics Board accident reports for 1948, show that of 850 fatal accidents in non-air-carrier flying, 45 percent involved stalls.

Research was begun in the early 1930's to find methods of improving the low-speed flying qualities of light aircraft, the first report being published in 1932 (ref. 1). There have been more recent projects (refs. 2 and 3) conducted for the same purpose. These reports furnished qualitative values but did not present quantitative results adequate for design purposes.

Thus it is seen that the aircraft designer has no convenient method with which to determine the variables in design in order to insure satisfactory handling qualities at or near the stall. This is proved by the wide variation in low-speed handling qualities of the various light airplanes now in existence. Of the current personal airplanes, three types have been designed with the aim of maintaining lateral control near the

stall and, under normal conditions, preventing stalling. These three types are generally referred to as "stall-resistant" aircraft. For the year 1948 the CAB points out that "The over-all average for single engined aircraft was 1 fatal stall out of but 186 aircraft. This is more than four times the rate of the stall-resistant aircraft." These facts prove that the designer can do much to decrease the rate of fatal stall accidents. Much of the danger associated with flying could be removed if the designer had quantitative information with which to design low-speed handling qualities into the personal airplane.

This investigation is based upon the hypothesis that satisfactory rolling control is obtainable by a human pilot only if the lateral stability factor, damping in roll, is positive. This in turn is dependent on the slope of the lift curve, where an increase in angle of attack is attended by an increase in lift. It then follows that, in order to retain sufficient rolling control under all conditions, the outboard elements of a wing must be prevented from stalling.

Flight tests have shown that, when an airplane is in stalled flight and autorotative moments are present together with violently changing burbled flow, a pilot cannot maintain satisfactory lateral control even with special devices such as spoilers which will give ample rolling moments for control. The difficulty is that the autorotative moments build up so rapidly that the pilot cannot react quickly enough to maintain the airplane at the lateral attitude desired (ref. 4).

The aim of this project is ultimately to furnish the designer with quantitative design information from which the proper combination of variables may be selected to insure satisfactory control near the stall. This involves determining the highest angle of attack at which satisfactory lateral control can be maintained and comparing this angle of attack with that for the maximum lift coefficient. From the comparison an estimate can be made of any possible sacrifice of low-speed performance which might be entailed by limiting the up-elevator travel to the point where the critical angle of attack is the maximum that can be maintained.

It has been fairly common design practice to twist the wing or to equip it with slots along the leading edge to control the spanwise location of the initial stall point. In the case of a rectangular wing with slots, the optimum effect in countering autorotation is attainable when the slot covers approximately the outboard 50 percent of the semispan (ref. 5). Most designers have employed slots of considerably shorter length. Slots of less than 35-percent length, however, while preserving aileron effectiveness behind the slots, do not eliminate the autorotative moments at angles of attack above that for the stall of the unslotted portion of the wing. In the present paper, both twist and slots are

considered as means of obtaining satisfactory lateral control at higher angles of attack near the stall. Whereas the data of reference 5 are derived from wind-tunnel tests of a model wing, the information presented herein is obtained from full-scale flight tests which take into account, among other things, the effect of body interference when the wing is in the high-wing position.

This work was conducted at the Personal Aircraft Research Center, Texas A. & M. Research Foundation, under the sponsorship and with the financial assistance of the National Advisory Committee for Aeronautics.

SYMBOLS

b	wing span, ft
C_L	wing or airplane lift coefficient
C_{l_p}	rate of change of rolling-moment coefficient C_l with wing-tip helix angle $pb/2V$
C_{l_δ}	rate of change of rolling-moment coefficient C_l with aileron angle δ
c	chord length, ft
\bar{c}_a	average chord of aileron behind hinge axis, ft
\bar{c}_b	average chord of aileron balance, ft
c_l	section lift coefficient
\bar{c}_{w_a}	average total chord of that portion of wing spanned by an aileron
k	aileron effectiveness factor, effective change in angle of attack of wing-aileron section per unit aileron deflection, $\Delta\alpha/\Delta\delta$
p	rolling velocity, radians/sec
V	airspeed, ft/sec
y	spanwise distance from airplane center line, ft
α	angle of attack, deg

α_{cr}	critical angle of attack for satisfactory roll recovery, taken as the entry angle of attack in steady flight with elevator and rudder held fixed throughout, from which the ailerons can be abruptly and fully deflected until maximum rate of roll is reached, then abruptly reversed and the airplane returned to level flight, all without changing the attitude in nose-down direction by more than 10° , deg
α_e	effective angle of attack, difference between geometric and induced angles, deg
α_i	induced angle of attack, deg
α_{mar}	unstalled margin of angle of attack, difference between $\alpha_{C_{lmax}}$ and α_{cr} , deg
β	angle of sideslip, deg or radians as noted
Γ	dihedral angle, deg or radians as noted
δ	aileron deflection, deg
$\Delta\delta_a$	angular difference between up and down ailerons, deg

Subscripts:

max	maximum value
min	minimum value

DESCRIPTION OF APPARATUS

Test airplane.- The test vehicle was a typical light airplane of high-wing arrangement with a wing plan form of zero taper and rounded tips as shown in figure 1; descriptive characteristics are given in table I. Special fittings were made to replace the upper attachments of the lift struts so that the amount of washout could be varied to 0° , 4° , and 8° at the tips. Later the airplane was flown with slots covering various portions of the span, always with 0° of washout. External riblets were fabricated from sheet aluminum and riveted to the nose ribs to adapt the slats to the existing airfoil, the contours and installation of which are shown in figure 2. It was not found practical to extend the slats around the curvature of the tips, but the effects were unimportant since these regions remained essentially unstalled at the critical angles of attack.

Progression of the stall was observed by telltale tufts affixed to the upper surface of the wing. Figure 3 shows the dome from which the tuft behavior was examined.

The cabin fuel tank, located forward of the instrument panel, was disconnected from the fuel system and only the wing cells were used, thereby minimizing the change of center-of-gravity location during flight. This procedure also afforded the facility of varying the center-of-gravity location merely by filling the cabin tank with water.

The human element in maintaining and reproducing steady conditions during the tests was eliminated by means of a device (fig. 4) which, when adjusted in position, permitted the elevator to be held fixed while allowing unrestricted aileron action. This device was mounted over the right-hand-side control-wheel shaft and hinged, as shown, to a reinforced area of the instrument panel. The front face of the slide was indented to match the protrusion on the plug secured to the end of the shaft. Slide position was calibrated against elevator deflection after the manufacturer's limit stop was removed.

Instrumentation.- All the instruments were nonrecording, the data being read and recorded by the pilot in most instances or by an observer. Both the altimeter and the airspeed indicator were sensitive instruments, the latter registering in 1-mph increments in the range from 10 to 80 mph, and were piped to an AN 5816-1 pitot-static head mounted 1 chord length ahead of the leading edge and 58 percent of the semispan out on the left side of the airplane. This installation is shown in figure 5. The calibration of the airspeed-indicator gage is shown in figure 6. The position element of the error for the calibration curve was derived by cross-plotting the angle-of-attack curves with the curve of the equation for upwash angles presented in reference 6.

Figure 5 also shows the vane-type angle-of-attack indicator and its mounting arrangement. Its location in the field of flow about the airfoil is one in which the error is comparatively small and varies almost linearly through the range of angles tested (ref. 6). It was chosen also for its convenience of observation to either the pilot or the observer. The instrument was calibrated in flight, the curve (fig. 7) being derived from the angle of climb and the angle between the root chord and the horizontal.

The yawmeter, which consisted of a vane mounted high enough above the fuselage to reduce the propeller slipstream effects to a minimum and which was connected by a long shaft to an indicator mounted in the roof of the cabin, was read by the pilot through a mirror system. Roll angles were measured either by a standard gyro horizon or by a grid read by visual reference to the actual horizon. Pitch angles were measured

through the medium of a graduated quadrant painted on the right-hand-side window of the cabin.

TEST PROCEDURE AND METHODS

The flight tests conducted may be collected in the following groups. With each wing configuration the entire group of tests was repeated with throttle full open and throttle closed and for three locations of the airplane center of gravity.

Variation of Lift Coefficient With Angle of Attack

Flight tests to determine the relation of lift coefficient to angle of attack were conducted in order to correlate flight test data with the calculated wing analysis and to determine the angle of attack for maximum lift coefficient.

The power-off lift curve was obtained by gliding at various angles of attack and observing the airspeed at each angle.

For the power-on lift curve a series of timed 200-foot climbs at various airspeeds was made, in order to plot a curve of rate of climb against airspeed. From the rate-of-climb curve the lift component of the engine thrust could be evaluated, and by combining this with power-on airspeed and angle-of-attack data the power-on lift curve was plotted. Since it was necessary to average the results from several climbs at each airspeed in order to obtain a smooth rate-of-climb curve, it was considered unnecessary to make refined calculations of engine output and the slight changes in rate of climb as the fuel load decreased.

Visual Observation of Progression of Stall by Use of

Tufts on Upper Surface of Wing

The aircraft was flown at a steadily increasing angle of attack until some portion of the wing was observed to be stalled. Then a constant airspeed was held until all the tufts in the stalled portion could be plotted. A number of runs were made at constant airspeed, decreasing the airspeed 1 mph for each run, until the stall was reached. Then the aircraft was stalled a number of times, with a few of the tufts being observed during each stall, until the behavior of all the tufts was plotted.

Determination of Maximum Angle of Attack Below Stall
at Which Lateral Control is Still Available

When an aircraft encounters gusts, substantial rolling velocity can be reached before the pilot can apply the proper correction. The rolling velocity is associated with a local increase in angle of attack over a portion of the wing which advances the stall at that point. The criterion of satisfactory control has been established in this project as the maintaining of lateral control when a gust induces a rolling velocity defined by $pb/2V = 0.05$ (the wing-tip helix angle expressed in radians). This value was determined by light-airplane flight tests described in reference 7.

The wing-tip helix angle developed by the ailerons has been computed from the equation for aileron effectiveness as given in reference 8:

$$\frac{pb}{2V} = \left(\frac{C_{l\delta}}{k} \right) \frac{k \Delta\delta_a}{114.6 C_{l_p}}$$

The rolling derivative, expressed as the ratio $C_{l\delta}/k$ is obtained by interpolation from figure 16 in reference 5; for an aspect ratio of 7.2 this is 0.495. The aileron effectiveness factor k is found by referring to figure 3 in reference 4; the test airplane was fitted with Frise type ailerons of which $\bar{c}_b/\bar{c}_a = 0.22$ and the ratio of aileron chord to wing chord \bar{c}_a/\bar{c}_{w_a} is 0.243, giving a value of k of 0.30. The rate of change of rolling-moment coefficient with wing-tip helix angle C_{l_p} is taken from figure 2 in reference 4; for an aspect ratio of 7.2 and a taper ratio of 1:1, this is 0.53. Thus, the equation becomes

$$pb/2V = 0.002445 \Delta\delta_a$$

which expresses the variation of wing-tip helix angle with aileron deflection. Since the ailerons were designed for equal up and down deflections of $\pm 22^\circ$, the maximum wing-tip helix angle is 0.002445 (44) or

$$pb/2V = 0.1076$$

This value is in substantial agreement with that found by flight test in reference 3 and puts the present investigation in a conservative light,

since it is generally accepted that the rate of roll that is likely to be produced by a gust corresponds to a wing-tip helix angle of the order of 0.05.

In order to simulate encountering a gust which would cause the above-mentioned rate of roll, the ailerons were deflected abruptly and held full over until the maximum rolling velocity was reached. The maneuver was started from steady straight flight and the elevator was maintained in a fixed position throughout the entire procedure. In the preliminary flight tests, the aileron deflection was held until a roll angle of 45° was reached. It was found that this roll angle resulted in the nose dropping considerably and the airspeed increasing. With this increased airspeed it was possible to roll back to level attitude, even though the aircraft was bordering on the stall when the ailerons were initially deflected. Investigation revealed that this aircraft reaches its maximum rolling velocity at between 7° and 10° of roll after full deflection of the ailerons (ref. 3). Therefore, in the main tests the full aileron deflection was held until an angle of roll of approximately 9° was reached.

As the roll angle of approximately 9° was reached, the ailerons were abruptly reversed and the reaction was noted. This procedure was repeated with the elevator maintained in a series of fixed positions, until the angle of attack nearest the stall was found at which satisfactory recovery resulted from the aileron reversal.

A secondary effect results from the yaw accompanying the rolling action, since the combination of yaw and dihedral is responsible for further increment of angle of attack which functions to advance the stall. On this account the maximum yaw which occurred during the roll and recovery maneuver was measured. In addition, the maneuvers were repeated starting with 5° of yaw, which represented the asymmetry likely to be produced by an inexperienced pilot.

Determination of Margin Below Stall at Which Aircraft

Would Not Spin

With varying amounts of up-elevator restriction, attempts were made to spin the aircraft by fully deflecting the rudder and holding the deflection a few seconds. From this procedure was found the angle of attack nearest the stall at which a spin could not be entered. This angle of attack was then compared with that found as critical for lateral control.

Lateral-Control Trials in Actual Gusty Air

Operation trials of the ailerons were made under conditions of severely gusty air, with the elevator held fixed at the position giving trim at the critical angle of attack at which good lateral control was available in the roll recoveries.

Determination of Effect of Abruptly Deflecting Elevator to Its Limited Position

At various airspeeds, both with power on and with power off, with the elevator limited to the deflection at which good lateral control was available, the elevator was abruptly deflected to its limited position. This was done to determine the speed margin from the stall at which the aircraft could be made to stall seriously and the type of stall which would result.

Three-Point Landings

The minimum amount of elevator angle required to make smooth three-point landings (landings with tail wheel and main wheels touching the ground simultaneously) was found by flight trials. These tests were made for each wing configuration and each center-of-gravity location.

RESULTS AND DISCUSSION

All results presented in this report, with the exception of the lift curves and the tests with the 100-percent slots, are from data obtained after installation of the observation dome. It was found by rechecks that the dome did not change the lift-curve results by any noticeable amount.

Variation of Lift Coefficient With Angle of Attack

The curves of C_L against α are given in figure 8 for the various amounts of washout and in figures 9(a) and 9(b) for the slotted configurations. The highest points shown represent the maximum values that were obtainable in steady unstalled flight.

Each curve includes points obtained with each of the three center-of-gravity locations tested, for no noticeable difference was found between them.

For the case of the plain wing with zero washout, the lift curves with and without power were the same at angles of attack up to about 12° and the angle of attack for maximum lift was the same. The curves separated at angles above 12° , however, the value of $C_{L_{max}}$ being higher with power on than with power off.

The lift curves for the wings with washout are displaced to the right merely because the angle of attack was taken from the chord at the center of the wing and does not represent the average for the entire wing.

The washout naturally increased the tendency of the wing to stall at the center first. With power on the effect of the slipstream appears to have countered this tendency to some extent, for with washout the maximum lift coefficient was not only higher with power on but it occurred at a higher angle of attack also. With power off the value of $C_{L_{max}}$ was reduced by washout, and the landing speed would be increased slightly (approximately 1 mph).

With certain of the slotted configurations the airplane could not be held in steady flight at angles of attack above that for the stall of the plain unslotted portion of the wing. The airspeed readings fluctuated up and down about ± 2 mph, and the value of the maximum lift coefficient could not be obtained with reasonable accuracy.

With the slots covering 30 percent of the span, smooth flight was obtained right up to the angle of attack for maximum lift, both with power off and with power on. The angle of attack for maximum lift, however, was no higher than that for the plain wing.

With the slot covering 90 percent of the span (all but the fuselage), the slipstream appeared to maintain the flow at the center, and with power on a high value of $C_{L_{max}}$ was obtained. Also, the angle of attack was 8° higher than that for the plain unslotted wing. With power off, the 90-percent-slot configuration gave smooth flight up to an angle of attack 3° higher than the plain wing. At higher angles of attack the lateral control and stability appeared to be satisfactory, but buffeting prevented smooth longitudinal control and steady flight.

This same irregular buffeting occurred at angles of attack above that for the stall of the plain wing with the 50-, 60-, and 70-percent-length slots, both with power on and with power off.

It was considered that the probable cause of the fluctuations in flight was a burbling of the air flow, but it was not certain whether the relevant burbling occurred in the center of the wing at the fuselage or on the horizontal tail surface. Either appeared possible. The horizontal

stabilizer might be stalled at the high angles of attack attained with the slotted wing, or the flow over the fuselage might be breaking down at the high angle of attack attained with the slotted wing, for the slat was not carried through over the fuselage because of the shape of the windshield in that region. It had been hoped that the flow over the fuselage would not break down, but the tests showed that it did except for the case with the 90-percent slots (all except the fuselage) with power full on.

To pursue this matter further it was decided both to investigate the flow conditions at the tail and to carry the slat across the fuselage, modifying it to provide an effective slot if possible. It was found necessary to change only the under surface of the slat across the fuselage as shown by the dotted line in figure 2. This provided what appeared to be a reasonable reduction in gap from the front to the rear of the slat.

With this 100-percent slot smooth flight was obtained at all angles of attack right up to the stall, with power off as well as with power on. The curves of lift coefficient against angle of attack are given in figure 9(b).

Since the slat over the fuselage resulted in smooth flight at high angles of attack for the case with the slot covering the entire span, it was thought that it might provide smooth flight also if it were used with the partial-span slots. The slat over the fuselage was therefore tried out in conjunction with the slots which came 60 percent inboard from the tips. The portions between the fuselage and the points 60 percent from the tips were plain unslotted wing. With this arrangement, however, the same irregular fluctuations occurred at the high angles of attack as for the original case without the center slat over the fuselage.

Investigation of Tail Stalling as Possible Cause of

Unsteady Flight

The angle of attack of the horizontal stabilizer may reach a high value when the airplane is held at a high angle of attack above that for the stall of the unslotted portion of the wing. It was thought that burbling might occur on the upper surface of the horizontal stabilizer even though the condition is relieved by the upward deflection of the elevator. To investigate this condition further tests were made with a vane-type angle-of-attack indicator located slightly ahead of the horizontal stabilizer about halfway out along the span and with tufts attached to the upper surface of the stabilizer. These were observed by the pilot through a suitably placed mirror and the tests were made with both the 90- and 100-percent slots, with power on and power off.

It was observed that the tail angle-of-attack indicator attained values above 20° and that it fluctuated over a fairly wide range, particularly in the slipstream with power on. At angles of attack of the tail above about 8° or 10° the tufts indicated that the air flow over the upper surface of the stabilizer was burbled. With the elevator deflected upward and the tail lift downward, however, the tail was operating well within its maximum lift coefficient and it was still effective as a control surface. The burbling over the horizontal stabilizer did not prevent the airplane from flying smoothly with the 100-percent slots at all throttle settings or with the 90-percent slots with power full on. The tail burbling was therefore not the cause of the fluctuations in the smooth flight of the airplane. These fluctuations were eliminated for the power-off condition by extending the slat across the fuselage from 90 to 100 percent of the span, indicating that the burbling which caused the longitudinal fluctuations in flight was in the region of the juncture between the fuselage and the wing.

Progression of Stall as Indicated by Tufts

The results of the tuft observation are shown in figures 10 to 17. The angle of attack and lift coefficient are given for each observation made under steady conditions. Where severe buffeting occurred the approximate angle of attack is given but a reasonably accurate value of the lift coefficient could not be obtained.

The action of the tufts is indicated by the symbols in the figures. A straight longitudinal line indicates smooth air flow. A wavy line indicates slightly unsteady flow, and an inverted V indicates that the tuft oscillated within the angle shown. Cross-hatched sections indicate completely burbled flow with the tufts flailing about in all directions or possibly pointing mainly forward.

In general, the progression of the burbling was carried out to the angle of attack giving the maximum lift coefficient obtainable. In no case except for the 8° of washout was it possible to obtain reasonable observations at angles of attack above that for maximum lift. For the configuration with 8° of washout observations could be made both with power on and with power off, but in neither case was the outer half of the span stalled.

The effect of the slots in maintaining smooth flow behind them at high angles of attack is apparent from an examination of figures 14 to 17.

Computations of Angle-of-Attack Variation Along Span

The span load distribution as computed for the plain untwisted wing in steady flight at an angle of attack just below the stall is given in figure 18(a). The computation was made by the method presented in reference 9.

The variation of the induced angle of attack along the span in steady flight is shown at the bottom of figure 18(b). The effective section angle of attack is the difference between the induced angle and the geometrical angle of attack of 16.3° . It is obvious that the stall should occur at the center first and that as the center stalls the sections near the wing tips should still be unstalled by several degrees. A qualitative agreement with this indication is shown by the tuft test of figure 10(b).

In like manner, the results of computations of induced angles of attack for the wing with 4° and 8° of washout are given in figures 19 and 20, respectively, and these can be compared with the tuft tests shown in figures 11(b) and 12(b).

The computations have been extended to include the effects of the rolling and the yaw that occurred as the ailerons were reversed in the roll-recovery tests. As no yaw measurements were taken with the wing twisted 8° , the maximum yaw angle was assumed to be 16° for the computations.

The change in angle of attack across the span of a rolling wing is considered to be influenced by two factors: (1) The rate of roll and (2) the angle of yaw in relation to the dihedral. Here, the yaw referred to is the aggregate yaw as measured in flight.

At the tip the increment of angle of attack due to the rolling velocity may be conveniently taken as being equal to the wing-tip helix angle, varying linearly across the semispan to zero at the airplane center line. As a first approximation to the increments due to yaw, in those cases where the wing incorporates dihedral, $\Delta\alpha$ may be taken as being equal to $\Gamma\beta$, where Γ is the dihedral angle in radians and β , the angle of sideslip, also in radians, and may be considered constant across the semispan (ref. 10). Figure 21 contains two charts for determining $\Delta\alpha$: (a) The variation across the span for wing-tip helix angles up to $pb/2V = 0.10$ and (b) the variation with angle of sideslip and dihedral angle expressed in degrees. In using figure 21(b), body interference in terms of the vertical location of the wing on the fuselage should be taken into account. This is qualitatively given in reference 11 as an increase in effective dihedral of 5° in the case of a high-wing monoplane and a corresponding decrease for a low-wing arrangement.

The angle-of-attack increments obtained from figure 21 for the combined effects of rolling and yaw are plotted as lines in figures 18, 19, and 20. The cross-hatched regions between these lines and the lines representing the section maximum lift coefficients indicate portions of the span that should have been stalled on the downgoing wing as recovery was started. Figure 18 shows that almost the entire span of the untwisted wing should have been fairly well stalled. With 8° of washout, on the other hand, figure 20 indicates that the outer third of the wing was unstalled, and at no part of the wing was the stall angle exceeded by a full degree. Since the tests with 8° of washout gave lateral control with no indication of autorotation at still higher angles of attack, it appears that the computations may exaggerate the stalled condition somewhat. This could well be, because the computations neglect such factors as the time required for the flow to break down in a stall and the influence of the burbled flow on the induced angles.

Included in figures 18, 19, and 20 are values of angle-of-attack increments for the combined effects of rolling and yaw for the more conservative value of $\text{pb}/2V$ of 0.05.

Maximum Angle of Attack Below Stall at Which Lateral

Control is Still Available

While the primary objective sought was that of determining the critical angle of attack for satisfactory lateral control in roll recovery (i.e., the greatest steady-flight angle of attack from which the airplane can be rolled and recovery effected by means of the ailerons without developing autorotation), the results yielded by the flight tests were different from what was expected. Partial stalling of the downgoing wing, from which autorotation derives its source, introduced another factor into the picture. The reduction in gross lift, together with the change in pitching moment, brought about a change in equilibrium which caused a nose-down change in attitude. The angle through which the airplane pitched was, of course, related to the extent of the stalled portion of the wing and only became noticeably apparent and measurable approximately 3° below the angle of attack which was taken as being critical for roll recovery. The severity of the pitching motion appeared to be greater when the roll was started from higher angles of attack, but it did not become violent until the angle of pitch attained 10° to 15° . In these instances, rather than a smooth lowering and subsequent raising of the nose, the motion was abrupt. With an increase in the angle through which the aircraft pitched there was a decreasing responsiveness to the ailerons. The pitching motion began when the maximum rate of roll was attained, at which time the ailerons were reversed for recovery. The decrease in aileron effectiveness was such that, when the entry angle of

attack was reached from which the pitching exceeded 10° , the roll-recovery response was extremely sluggish. Recovery was probably rendered possible only by the increase in airspeed and the over-all decrease in angle of attack coincident with the nose-down change in attitude.

At angles of attack slightly higher than the critical angle the pitching became more severe but the angles at which autorotation and spinning resulted were too close to the stall to be considered reliable, as, even in straight flight at these entry angles, stalls would occasionally occur. It is mentioned here again that the rolls were performed with the elevator held fixed and that, therefore, no means of control were available to prevent the nose-down change in attitude. The importance of the nose-down change in attitude is more readily appreciated when consideration is given the conditions leading to accidental spinning resulting from, for example, a steep turn near minimum speed. The large amount of elevator up travel usually provided allows the pilot instinctively to pull back on the control at the first signs of lowering of the nose since he is taught that the nose must be held up by means of the elevator in executing turns. By pulling back on the control the stalled condition is thus further aggravated, resulting in a loss of positive damping in roll. This renders the ailerons ineffective in coping with the lateral instability that ensues. It is apparent then, at least for wing arrangements with which the stall begins well inboard, that rolling control is available almost up to the stall as long as the elevator is designed not to overcome the nose-down change in attitude. Limiting the upward elevator deflection introduces other problems in over-all performance of the airplane that will be discussed later in this paper; but in its relationship to satisfactory roll recovery the angle of attack that is associated with the limitation is of paramount importance, since the extent of the stalling of the downgoing wing during a roll and therefore the magnitude of the longitudinal pitching are both dependent upon the angle of attack.

The downward displacement of the flight path, incurred with the nose-down change in attitude, was found during preliminary trials to be greater than approximately 50 feet when the angle through which the airplane pitches exceeds 10° , coinciding with the change in the nature of the pitching motion and the decrease of aileron response in roll recovery. Since the conditions surrounding the purpose of this investigation involve flight at low altitude, such as maneuvering in the approaches of an airport, an unanticipated loss of more than 50 feet of altitude due to the lack of reserve elevator deflection might be as dangerous as the spin that could result from the nose being held too high; and since the pitching motion became severe and the aileron response became unacceptably sluggish only when the change in attitude exceeded 10° , it is this criterion that was used as a measure during the flight tests. The critical angle of attack for satisfactory roll recovery, therefore, is taken as the entry angle of attack in steady flight with the elevator

and rudder held fixed throughout, from which the ailerons can be abruptly and fully deflected until the maximum rate of rolling is reached, then abruptly reversed and the airplane returned to level flight, all without changing the attitude in a nose-down direction by more than 10° . The critical angles of attack are presented in table II as found by flight test.

Effect of center-of-gravity location on lateral control.- The tests were all repeated with three different center-of-gravity locations. With each wing configuration all three center-of-gravity locations gave substantially the same critical angle of attack for satisfactory lateral control in roll recovery. The single value for the critical angle given in table II for each configuration therefore represents the results obtained with all three center-of-gravity locations.

Effect of yaw on lateral control.- The yaw measurements shown in table II are the maximum values encountered during the process of the roll. They occurred just after the ailerons were reversed for recovery. The initial yaw of 5° was applied by means of the rudder, the wings being held level with the ailerons prior to the actual maneuver. The yaw was in a direction that added to the aileron adverse yaw and the yaw developed by the roll and represents the directional asymmetry likely to be unwittingly produced by the inexperienced pilot. With the exception of the plain untwisted wing, the addition of 5° of initial yaw affected the yaw measurements only to a small extent but in all instances did not measurably affect the critical angles of attack. The critical angles remained unchanged for rolls to the left and to the right.

Roll control with plain untwisted wing.- The critical angle of attack with the plain untwisted wing was found to be 1.2° below the stall without power and 1.3° with power full on (table II). This margin below the stall was not only substantially the same with and without power but, as stated previously, it was in each case the same with three different locations of the center of gravity.

The loss in lift that would be entailed by not flying above the critical angle of attack would result in an increase in the landing speed of 1 mph with the test airplane. This small speed sacrifice would appear to be well worth while in order to insure satisfactory lateral control at low speed. It could be obtained for any one center-of-gravity location and power setting by providing only sufficient up-elevator travel to maintain steady flight at the critical angle of attack. Although the critical angle-of-attack margin is substantially the same for all center-of-gravity and power conditions for this airplane configuration, unfortunately the elevator deflection producing this angle of attack varies widely with center-of-gravity and power changes as shown by the following table:

Location of c.g., percent M.A.C.	Elevator deflection for critical α for roll recovery, deg	
	Power on	Power off
27.3	-3.8	-9.5
30.4	-.3	-4.4
32.3	1.9	-2.7

It is apparent that the airplane with a plain untwisted wing could not be used satisfactorily with a single limitation of the up-elevator travel to insure satisfactory lateral control at low speed. If the up travel were limited to 1.9° for the case of rearward center of gravity with power on, the entire low-speed end of the operating range would be sacrificed in the case of forward center of gravity with power off, for the latter case requires 11.4° more up-elevator deflection. The arrangements with washout and leading-edge slots were investigated with the thought that they might help to alleviate this situation.

Effect of washout on lateral control near stall.- With both 4° and 8° of washout the critical angle for roll recovery with power on was found to have the same margin below the stall as with the plain untwisted wing, about 1° (table II). With power off a margin of about 2.7° was required, but the limitation was not associated with loss of lateral control. The damping in roll and aileron control were satisfactory at higher angles of attack, but the stalling of the center portion of the wing caused a downward pitching of more than 10° and the longitudinal flight was somewhat unsteady. With 8° of washout the aileron control itself was satisfactory with the angle of attack well beyond that for $C_{l_{max}}$, both with power on and with power off. The bottom diagrams in figures 12(a) and 12(b) show that the entire outer half of the wing was unstalled under those conditions. The critical angle of attack for control was selected well below the angle for $C_{l_{max}}$, however, because of the longitudinal unsteadiness at the higher angles of attack.

Effect of slots on lateral control near stall.- Reliable results were obtained for the 30-percent and the 100-percent slot lengths in both the power-on and power-off conditions and for the 90-percent slot length in the power-on condition only (table II). In the 30-percent-slot configuration the aircraft behaved almost identically like that with the plain untwisted wing, leading to the conclusion that with wing arrangements such as that tested no improvement in rolling control can be expected from slots of such short length. This is in agreement with a similar finding with another airplane as given in reference 3.

As with the washout mentioned above, but to a greater extent, the critical angles of attack shown for the 50-, 60-, and 70-percent slot lengths are only apparent and are not related to roll recovery; stalling of the unslotted inboard portions of the wing produced buffeting which not only brought about the change in longitudinal trim from which nose-down pitching resulted far below the angle at which rolling control deteriorated but also made it impossible to maintain steady flight above the angles shown. For this reason it was not possible to provide the unstalled margins pertinent to the configurations concerned.

It is noted here that, while the pilot was able to fly the test airplane at angles of attack higher than the angle at which buffeting first manifested itself, the variations in longitudinal trim precluded any accurate measurement closer than $\pm 2^\circ$. The effects of the buffeting were more obvious in the tests with the configuration in which 90 percent of the semispan was covered by the slots (the inboard ends of the slats were in line with the sides of the fuselage), where satisfactory rolls and recoveries were performed with power on at an angle of attack 2.9° below the stall. The turbulence over the fuselage during the power-off tests caused unsteadiness which rendered the downward displacement of the flight path as the critical factor at an angle of attack 9° below the stall. Actually, rolls performed in the unsteady flight range less than 9° from the stall, though too erratic longitudinally to provide reliable measurements, indicated qualitatively at least that from the standpoint of aileron response alone the critical angle of attack with power off should have closely approximated that of the condition of power on.

With the slot covering the entire span including the fuselage, satisfactory roll control was obtained within a margin of 1.9° below the stall with power on and 2° below the stall with power off (table II). These margins between the critical angle of attack and the stall are only slightly greater than that for the plain wing and are no more than might be expected because of the sudden decrease in lift at the stall which is associated with the higher maximum lift coefficient given by the slotted wing.

The values used for the 100-percent slot are the most critical ones taken from the 25.1- and 28.9-percent-mean-aerodynamic-chord center-of-gravity locations. With a 33.6-percent-center-of-gravity location substantially greater margins were required to insure satisfactory lateral control, 3.7° with power on and 4.6° with power off. The center of pressure of the wing system is moved forward by the addition of the slat and the tests indicated that a center-of-gravity location at 33.6 percent of the mean aerodynamic chord of the main wing is too far back for satisfactory flight. With the two more forward center-of-gravity locations, however, the lateral control was quite satisfactory.

Margin Below Stall at Which Airplane Would Not Spin

Early tests such as those of reference 1 showed that, if an airplane had insufficient up-elevator travel for it to be put into a spin, the ailerons were effective at the highest angle of attack and lowest speed that could be maintained. In the present program this spin condition was investigated for comparison with the critical angles of attack found in the roll-recovery tests.

The results of the spin-entry tests are contained in table III. At the angles shown, full deflection of the rudder alone produced a spiral, and opposite application of rudder and ailerons resulted in a forward slip. Above these angles, but below the stall, autorotation was slow in developing. The spins thus obtained were only of $3/4$ - to $1\frac{1}{2}$ -turn duration, becoming tight spirals with the airplane in a steep nose-down attitude.

The critical angles of attack for nonspinning were not affected by changes in the location of the center of gravity within the range tested, with the exception of the 100-percent slot as noted later. The differences between left and right for the power-on condition are presumably due to the engine torque and slipstream effects.

Spin entry with plain untwisted wing.- With power off the plain untwisted wing gave the same critical angle of attack for spin entry as for lateral-control roll recovery. With power on substantially the same value was also obtained for a right-hand spin entry. The airplane would enter a full-power left-hand spin from an angle of attack about 1.1° lower, however, and a margin below the stall of 2.5° was required to prevent the possibility of spinning to the left with full throttle.

Effect of washout on spin prevention.- With the 4° of washout, engine idling, and the 8° of washout at full throttle, spins could be entered and held only when the unlimited elevator deflection of 30° was fully applied at the instant of the stall. With power off, spins could not be accomplished at all with the 8° of washout.

Effect of slots on spin prevention.- Because of the inability to maintain steady flight at angles of attack above that of the stall of the plain unslotted portion of the wing, as previously discussed, no data are given for the 50-, 60-, and 70-percent-slot configurations and for the 90-percent-slot configuration with the engine idling.

With the 30-percent slots, and with the 90-percent slot for the power-on condition, the spin criterion was not so critical as that for lateral control against a roll.

For the case of the 100-percent slot, which is the exception mentioned above, the margin varied greatly with variation in center of gravity for spins to the left with full power on. For this reason the values for the two forward center-of-gravity locations are given separately for the 100-percent slot in table III. The spin margins are not critical for spins with power off or for spins to the right with power on. The avoidance of spins to the left with power on, however, requires substantially larger margins than those to insure satisfactory lateral control. The unusually large margin required to prevent the possibility of spinning to the left with the 100-percent slot was unexpected, particularly because it did not occur with the 90-percent slot. A suitable explanation has not yet been found.

As in the case of the lateral-control tests, the spin tests indicated that the 33.6-percent-mean-aerodynamic-chord position of the center of gravity was found to be too far back for satisfactory flight conditions, for the airplane could be spun to the left at relatively low angles of attack when full power was used. In fact, it appears that with the full-span slat it might be desirable to keep the center of gravity ahead of the 25-percent position on the main wing.

Lateral Control Under Actual Gusty Air Conditions

Because the roll-recovery tests were conducted in smooth air and the data interpreted in terms of gusty air conditions, it was considered desirable to examine the validity of the critical angles of attack under actual conditions of turbulence. The airplane was flown in rough air, with estimated gust velocities ranging up to 13 feet per second, with the elevator deflected to provide an angle of attack corresponding to the critical roll-recovery angle pertinent to the configuration. The elevator deflections for the three center-of-gravity locations, with power on and off, are included in table IV.

The critical angles generally were adequate for preserving lateral control in the gusty air encountered. They were not satisfactory, however, from the standpoint of longitudinal trim, as the momentary change in angle of attack caused by the gusts was occasionally great enough to extend beyond the margin of angle of attack. On those occasions stalling occurred at the center of the wing, and the resultant pitching was at times quite abrupt. For all the configurations, it was found that all that was required to gain satisfactory longitudinal action was a further reduction in upward elevator deflection of 1.5° . This involved a 1.5° reduction in critical angle of attack for the plain untwisted wing and a reduction of 4° in the case of the 90-percent-slot configuration with power on.

Abrupt Displacement of Elevator Control

The resultant behavior of the airplane when the elevator was suddenly displaced upward and held was studied for various entry speeds and center-of-gravity locations with the maximum deflection limited to that of satisfactory roll recovery with the center of gravity rearward. This was carried out to determine whether any dangerous attitudes, such as whipstalls, could result from abuse of the elevator control within the range permitted by the limitation.

Pulling the control back against the stop at a speed 5 mph above minimum speed with full power and rearward center of gravity resulted in a gentle stall with the plain untwisted wing, the 4° and 8° of washout, and the 90- and 100-percent slot lengths.

With power off an entry speed 10 mph above the stall was required. In order to achieve a stall with the same elevator restriction when the center of gravity shifted to the intermediate and forward locations, speeds in excess of 25 mph above the stall were needed. With entry speeds up to 40 mph above V_{min} , the stalls thus performed did not become violent, the wings remaining level throughout each maneuver.

With power on, on the other hand, at entry speeds of 20 mph above V_{min} , center of gravity rearward, considerable momentum was developed which permitted reaching 5° beyond the stall angle of attack and under these conditions the airplane displayed a marked tendency to roll off to the right.

Extreme whipstalls were attempted with the 90-percent-slot configuration. With power off entry speeds 60 mph above V_{min} yielded angles of attack 7.5° above the stall and indicated airspeeds as low as 18 mph. At increased entry speeds, while no longitudinal "whipping" motion was observed, the airplane did, however, roll off to the right or to the left. Under these conditions no one direction of roll predominated. The extreme whipstall attempts were not continued beyond the speeds mentioned because of the possibility of structural damage to the aircraft.

From these tests it appears that if the maximum up-elevator position were just enough to maintain the critical angle of attack in steady flight, no serious loss of control need be expected from any ordinary inadvertent mishandling of the elevator at low speeds.

Three-Point Normal Landings

Minimum upward elevator deflections needed for safe normal landings are included in table IV for three center-of-gravity locations. These deflections are compared with those of the other criteria examined and

discussed in the next section. They represent the deflections with which the main and tail wheels may be simultaneously brought into contact with the runway surface under conditions of smooth air and precise landing technique. Errors in judgment tended to bring the tail wheel down first; even when the main wheels accidentally made initial contact, the aircraft rebounded and the corrective technique was applied. Safe landings were executed in moderate cross winds and in gust conditions.

Résumé of Results With Consideration of Maximum Elevator Deflections

The summary of elevator deflections presented in table IV compares the critical deflections for roll recovery, nonspinning, and three-point landings for three center-of-gravity locations, with power on and off, thus enveloping the entire performance range investigated. Considering only those configurations where reliable results were obtained and neglecting, therefore, the 50-, 60-, and 70-percent-slot configurations and the 90-percent-slot configuration in the power-off condition, it is readily apparent that the wide scatter of elevator deflections required is incompatible with the design characteristics sought.

Plain untwisted wing.- As noted previously the critical angle of attack for the plain untwisted wing was found to be approximately 1.3° below the stall for all conditions of power and center of gravity tested, and this represents an increase in the landing speed of approximately 1 mph.

The effect of power on the elevator position required to trim at this critical angle of attack is shown in table IV. The difference in elevator position, with power off and power on, is approximately 5° and the corresponding difference in airspeed is about 9 mph.

The effect of center-of-gravity change was also found to be large, even with the relatively moderate 5-percent variation covered in the tests. With power off, the forward center of gravity required an elevator deflection 6.8° higher than the rearward center of gravity. This would represent a loss of 10 mph if the rearward center-of-gravity critical elevator deflection were used with the forward center-of-gravity location. With power on, the difference between critical elevator deflections of 5.7° entails an airspeed difference of 14 mph.

Considering both center-of-gravity variation and power variation, the lowest critical elevator deflection occurred with power on and rearward center of gravity, and the highest deflection occurred with power off and forward center of gravity. The difference in critical elevator angles between these extreme conditions was 11.4° . The airspeed

corresponding to the critical angle of attack with the rearward center of gravity and power on was 42.5 mph. If the same elevator position were used with the forward center-of-gravity location and the engine throttled, the minimum airspeed would be 66.5 mph, an increase of 24 mph. This sacrifice of the low speed range with the forward center-of-gravity location is obviously not acceptable in general operation.

A conventional three-point landing with the forward center-of-gravity location required an upward elevator deflection of 14.1° . An examination of table IV shows that allowing deflections that would permit three-point landings to be made would not confine the angles of attack obtainable to a range insuring satisfactory roll recovery and nonspinning characteristics.

Although the original configurations with the plain untwisted wing had critical angles of attack for satisfactory lateral control and nonspinning characteristics that were uniformly about 1° below the stall, it is obvious that the wide scatter of the required elevator deflections is incompatible with the use of a single maximum deflection producing all of the flight characteristics sought. This condition was more or less expected, and the variations in washout and slot length were investigated with the thought that they might lead to more usable configurations.

Effect of washout.- The washout improved the aileron control at high angles of attack. In fact, with 8° of washout the aileron control itself was satisfactory at the highest angle of attack that could be maintained with every condition of center of gravity and power tested, even with the elevator at its maximum possible upward deflection of 30° . The angle of attack was in each case well beyond that for the airplane maximum lift coefficient, but the tufts showed that the outer half of the wing was unstalled.

These favorable conditions are not indicated in table IV because the critical angles of attack for satisfactory roll control were limited by the longitudinal fluctuations which accompanied the stalling of the center portion of the wing. Further investigation into the possibility of eliminating the longitudinal fluctuations appears well warranted.

If the critical angles of attack were not reduced because of the longitudinal fluctuations but were based on the lateral control alone, ample up-elevator control would be available to make three-point landings for the case with 8° of washout. Even with the low critical angle of attack which eliminates the longitudinal fluctuations for the power-off condition, sufficient elevator control was available to make three-point landings with the 8° washout case having the center of gravity at 27.3 percent of the mean aerodynamic chord. This is the only unslotted case tested which met these desirable characteristics, and they were met only for the power-off condition for one center-of-gravity location.

Effect of slots.- It was anticipated that the slots covering at least the outer half of the span or more would maintain the damping in roll up to substantially higher angles of attack and that satisfactory roll control might be obtained, even while the elevator was held to the deflection required to make three-point landings with the forward center-of-gravity location. Considering only the aileron control by itself, this anticipation appears to have been justified, but in general the longitudinal fluctuations occurred at high angles of attack. The fluctuations were similar to those which occurred with the washout but were more severe. The 90-percent-slot configuration was an exception when full power was used, but in throttled flight the fluctuations were unacceptable at high angles of attack.

The 100-percent slot eliminated the longitudinal fluctuations and gave smooth flight right up to the stall, both with power on and with power off. Also, it increased the angle of attack for the maximum lift coefficient by 6° . Even under this favorable condition, however, it was only with the most forward center-of-gravity position tested that three-point landings could be made with maximum up elevator at the deflection which was just enough to insure satisfactory roll control with power off.

The ground effect is a large adverse factor in getting the tail down for a three-point landing. In the case just mentioned an elevator angle of 17.5° was required to make a three-point landing. For this the wing angle of attack is 14.8° at touch down, whereas in a glide clear of the ground the same elevator position will give a wing angle of attack of 20° , or 5.2° higher.

This entire problem of a three-point landing at low speed can be eliminated, of course, by the use of the tricycle landing gear which does not require the three-point landing.

With power full on the 17.5° elevator travel produced a much higher angle of attack, sufficient to stall the airplane thoroughly. It is apparent from all of the wing arrangements tested that the airplane configuration of this investigation requires substantial revision if a given elevator setting is to produce the desirable condition in which the angle of attack is no higher with power on than with power off.

With the fully slotted wing, as well as with the 8° of washout, the forward center-of-gravity position was the only one having sufficient elevator control to make three-point landings but at the same time having just sufficient elevator control not to exceed the angle of attack for satisfactory lateral control with power off. Extrapolation of the data indicates that with the 100-percent slot it should be possible to accomplish this condition throughout a center-of-gravity range from 21 to 25 percent by a maximum elevator deflection of approximately 19° .

CONCLUDING REMARKS

There are two paths toward attainment of the reliable low-speed control conditions sought. One of these is increasing the angle of attack at which damping in roll is effective to a point beyond the highest angle of attack that is required in steady flight or in landing. The washout and the wing slots of the present tests follow this path, but each was successful in the present investigation only for power-off flight and for a narrow range of center-of-gravity locations.

The other path involves the reduction of the scatter of the maximum elevator deflections required with the various power and center-of-gravity conditions. The change of trim due to power is influenced by such factors as the position and inclination of the thrust axis and the influence of the slipstream on the tail surfaces with the elevator deflected. The center-of-gravity travel is influenced by the configuration of the airplane with respect to the placement of the variable loads. The attitude (and elevator deflection) required in landing is influenced by the form and proportions of the landing gear.

It is desirable that both of these paths be investigated to the point where reliable control will be generally available at the lowest speeds and the highest angles of attack that can be maintained in flight.

Agricultural and Mechanical College of Texas,
College Station, Texas, September 25, 1952.

REFERENCES

1. Weick, Fred E.: Preliminary Investigation of Modifications to Conventional Airplanes to Give Nonstalling and Short-Landing Characteristics. NACA Rep. 418, 1932.
2. Hunter, P. A., and Vensel, J. R.: A Flight Investigation to Increase the Safety of a Light Airplane. NACA TN 1203, 1947.
3. Hunter, Paul A.: Flight Measurements of the Flying Qualities of Five Light Airplanes. NACA TN 1573, 1948.
4. Weick, Fred E., and Soulé, Hartley A., and Gough, Melvin N.: A Flight Investigation of the Lateral Control Characteristics of Short Wide Ailerons and Various Spoilers With Different Amounts of Wing Dihedral. NACA Rep. 494, 1934.
5. Weick, Fred E., and Wenzinger, Carl J.: Effect of Length of Handley Page Tip Slots on the Lateral-Stability Factor, Damping in Roll. NACA TN 423, 1932.
6. Huston, Wilber B.: Accuracy of Airspeed Measurements and Flight Calibration Procedures. NACA Rep. 919, 1948. (Supersedes NACA TN 1605.)
7. Weick, Fred E., and Wenzinger, Carl J.: Wind-Tunnel Research Comparing Lateral Control Devices, Particularly at High Angles of Attack. I - Ordinary Ailerons on Rectangular Wings. NACA Rep. 419, 1932.
8. Gilruth, R. R., and Turner, W. N.: Lateral Control Required for Satisfactory Flying Qualities Based on Flight Tests of Numerous Airplanes. NACA Rep. 715, 1941.
9. Sivells, James C., and Neely, Robert H.: Method for Calculating Wing Characteristics by Lifting-Line Theory Using Nonlinear Section Lift Data. NACA Rep. 865, 1947. (Supersedes NACA TN 1269.)
10. Pearson, Henry A., and Jones, Robert T.: Theoretical Stability and Control Characteristics of Wings With Various Amounts of Taper and Twist. NACA Rep. 635, 1938.
11. House, Rufus O., and Wallace, Arthur R.: Wind-Tunnel Investigation of Effect of Interference on Lateral-Stability Characteristics of Four NACA 23012 Wings, an Elliptical and a Circular Fuselage and Vertical Fins. NACA Rep. 705, 1941.

TABLE I.- DIMENSIONAL CHARACTERISTICS OF TEST AIRPLANE

Wing type	High strut-braced
Landing gear	Fixed
Engine	Four-cylinder horizontally opposed
Rated power, hp at rpm	65/2450
Normal gross weight, lb	1050
Propeller diameter and pitch, in.	72, 44
Number of blades	2
Wing loading, lb/sq ft	5.84
Power loading, lb/hp	16.15
Wing airfoil section	NACA 23012
Wing plan form	Zero taper with rounded tips
Wing area including fuselage, sq ft	180
Wing span, ft	36
Mean aerodynamic chord, ft	4.98
Aspect ratio	7.2
Dihedral, deg	1.0
Wing incidence, deg	3.8
Flap	None
Aileron type	Frise
Aileron area (each), sq ft	8.7
Aileron deflection, deg	±22
Aileron span, percent $b/2$	44.0
Aileron moment arm, percent $b/2$	^a 73.7
Horizontal tail length, ft	^b 15.58 (approx.)
Stabilizer area, sq ft	15.0
Stabilizer incidence, deg	0
Horizontal tail span, ft	10.0
Maximum stabilizer chord, in.	26.88
Elevator area, sq ft	10.8
Elevator deflection, deg	27 up, 27 down
Elevator type	Plain flap
Elevator trim tab deflection, deg	38 up, 33 down
Elevator span times mean chord squared, cu ft	12.60
Vertical tail length, ft	^c 15.91 (approx.)
Fin area, sq ft	3.5
Rudder area, sq ft	6.2
Rudder deflection, deg	±26
Rudder type	Plain flap
Balance area (rudder)	0
Directional trimming device	Small fixed tab
Type of cockpit control	Wheel



^aMidspan of aileron to center line of airplane.

^bLeading edge of wing root chord to elevator hinge line.

^cLeading edge of wing root chord to rudder hinge line.

TABLE II.- CRITICAL ANGLE OF ATTACK FOR SATISFACTORY ROLL RECOVERY
($p_b/2V = 0.10$) AND THE MARGIN BELOW THE STALL

Configuration	Power	α_{cr} , (deg)	α_{mar} , (deg)	Maximum yaw during rolling action and recovery, deg			
				Straight flight		5° initial yaw	
				Left roll	Right roll	Left roll	Right roll
		(a)	(a)				
0° of washout	On	15.7	1.3	10	12	15	16
	Off	15.8	1.2	12	12	16	17
4° of washout	On	17.5	1.2	13	14	17	15
	Off	16.2	2.6	13	13	15	15
8° of washout	On	19.2	1.0	(b)	(b)	(b)	(b)
	Off	17.5	2.7				
30-percent ^c slot, 0° of washout	On	15.5	1.4	11	17	12	16
	Off	15.4	1.5	12	14	12	13
50-percent ^c slot, 0° of washout	On	^d 15.6	---	12	17	11	16
	Off	^d 15.4	---	12	12	11	12
60-percent ^c slot, 0° of washout	On	^d 15.7	---	14	14	16	15
	Off	^d 15.4	---	13	15	14	15
70-percent ^c slot, 0° of washout	On	^d 15.7	---	15	14	16	15
	Off	^d 15.5	---	12	13	14	15
90-percent ^c slot, 0° of washout	On	21.9	2.9	15	24	16	24
	Off	^d 15.8	9.0	15	16	15	17
100-percent ^c slot, 0° of washout ^e	On	21.6	1.9	15	13	16	19
	Off	19.5	2.0	9	12	20	16

^aRelative to root chord.

^bTests run before yaw was added to procedure.

^cLocation of inboard end of slat, percent $b/2$ from wing tip.

^dCritical α limited by buffeting.

^eWith the 100-percent slot, the results from the 33.6-percent M.A.C. c.g. location have been eliminated as being unsatisfactory. The results given are the most critical for the other two c.g. locations tested, 25.1 percent M.A.C. and 28.9 percent M.A.C.

TABLE III.- CRITICAL ANGLES OF ATTACK AND UNSTALLED
MARGINS FOR NONSPINNING

Configuration	Power	α_{cr} , deg (a)		α_{mar} , deg (a)	
		Left	Right	Left	Right
0° of washout	On	14.6	15.7	2.5	1.4
	Off	15.8	15.8	1.2	1.2
4° of washout	On	15.7	18.8	3.1	0.6
	Off	(b)	(b)	0	0
8° of washout	On	(b)	(b)	0	0
	Off	(b)	(b)	0	0
30-percent ^c slot	On	15.5	16.2	1.4	0.7
	Off	16.0	16.1	.9	.5
50-percent ^c slot	On	----	----	---	---
	Off	----	----	---	---
60-percent ^c slot	On	----	----	---	---
	Off	----	----	---	---
70-percent ^c slot	On	----	----	---	---
	Off	----	----	---	---
90-percent ^c slot	On	22.6	24.1	2.2	0.7
	Off	----	----	---	---
100-percent ^c slot, c.g. at 25.1 percent M.A.C.	On	18.8	(d)	4.7	0
	Off	(d)	(d)	0	0
100-percent ^c slot, c.g. at 28.9 percent M.A.C.	On	14.5	(d)	9.0	0
	Off	(d)	(d)	0	0

^aRelative to root chord.

^bSee text.

^cLocation of inboard end of slat, percent $b/2$ from wing tip.

^dAngle of attack to spin higher than that for maximum lift coefficient.



TABLE IV.- SUMMARY OF CRITICAL ELEVATOR DEFLECTIONS^a

Configuration	c.g. location, percent M.A.C.	Deflections, deg, for -				
		Roll recovery		Nonspinning		Three-point landing
		Power on	Power off	Power on	Power off	
0° of washout	27.30	-3.8	-9.5	-3.0	-9.5	-14.1
	30.40	-.3	-4.4	+2	-4.4	-10.1
	32.30	+1.9	-2.7	+2.5	-2.7	-9.5
4° of washout	27.30	-4.9	-10.7	-3.7	None	-14.1
	30.40	-1.5	-6.7	-.4	None	-9.5
	32.30	+8	-4.4	+2.0	None	-9.0
8° of washout	27.30	-7.2	-13.6	None	None	-13.6
	30.40	-3.8	-9.5	None	None	-11.3
	32.30	-1.5	-7.2	None	None	-8.4
30-percent ^b slot	26.13	-5.8	-12.8	-5.9	-13.4	-18.0
	29.53	-2.2	-7.9	-2.3	-8.6	-14.0
	34.08	+2.0	-1.1	+1.9	-1.8	-9.0
50-percent ^b slot	25.75	-6.0	-12.6	----	-----	-17.0
	29.15	-1.9	-7.5	----	-----	-12.0
	33.60	+2.5	-1.0	----	-----	-8.0
60-percent ^b slot	25.55	-5.6	-12.5	----	-----	-16.0
	28.95	-2.0	-7.3	----	-----	-12.0
	33.50	+3.7	-.6	----	-----	-7.0
70-percent ^b slot	25.40	-5.8	-12.7	----	-----	-16.5
	28.80	-1.8	-7.0	----	-----	-11.0
	33.35	+3.3	-.9	----	-----	-7.0
90-percent ^b slot	25.00	-6.0	-13.1	-7.7	-----	-14.5
	28.40	-2.1	-8.0	-3.4	-----	-11.0
	32.95	+1.9	-2.3	+1.2	-----	-7.0
100-percent ^b slot	25.1	-9.7	-19.1	-8.0	-27.0	-17.5
	28.9	-5.0	-8.5	-1.0	-15.5	-14.5
	33.6	+2.0	-2.0	+ ?	-13.5	-7.0

^aElevator deflections: (-) up, (+) down.

^bLocation of inboard end of slat, percent b/2 from wing tip.



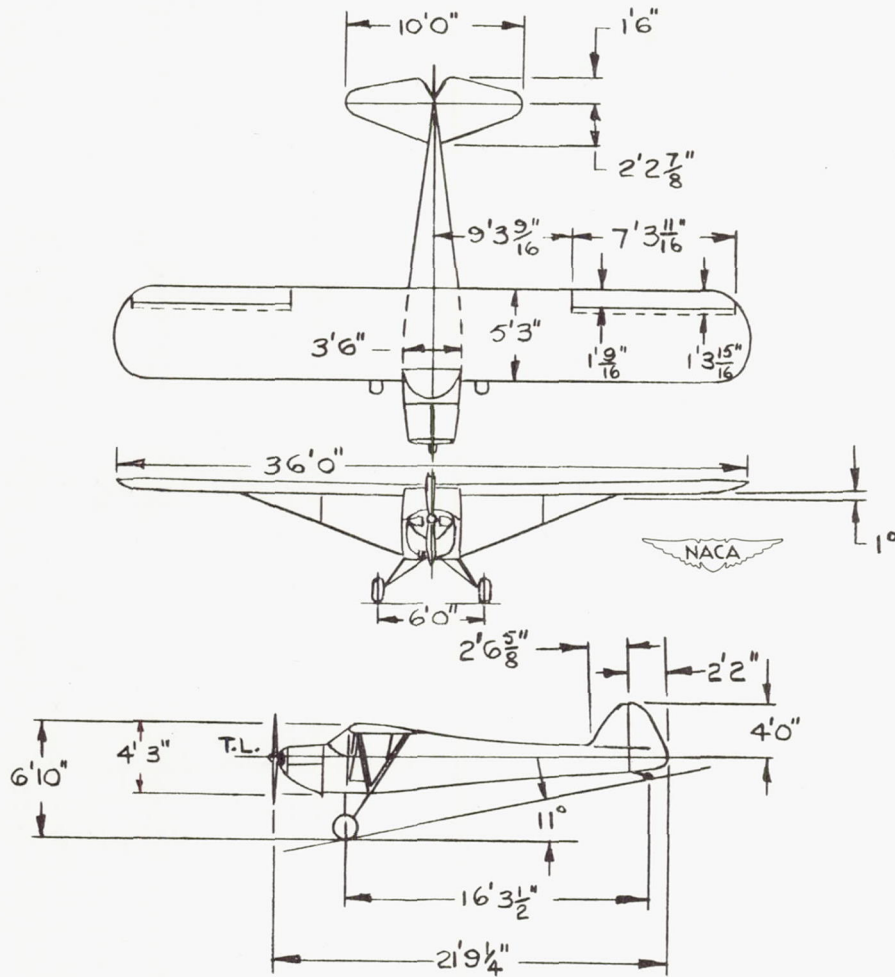
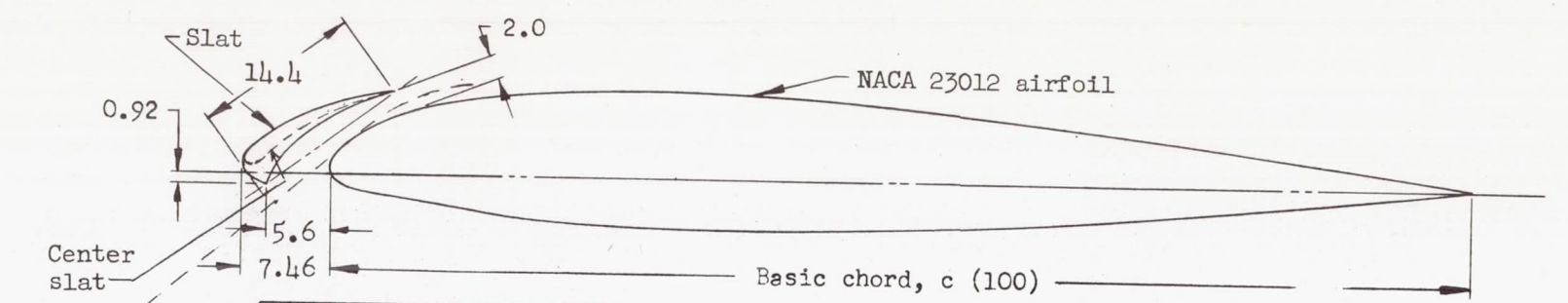

Figure 1.- Three-view drawing of test airplane.



NACA 23012 airfoil (Percent basic chord)		
Station	Upper	Lower
0	-----	0
1.25	2.67	-1.23
2.50	3.61	-1.71
5.0	4.91	-2.26
7.5	5.80	-2.61
10	6.43	-2.92
15	7.19	-3.50
20	7.50	-3.97
25	7.60	-4.28
30	7.55	-4.46
40	7.14	-4.48
50	6.41	-4.17
60	5.47	-3.67
70	4.36	-3.00
80	3.08	-2.16
90	1.68	-1.23
95	.92	-.70
100	(.13)	(-.13)

Leading-edge radius: 1.58
Slope of radius through end of chord: 0.305

Slat (Percent slat chord)			
Station	Upper	Lower	Lower, center
0	12.97	12.97	
1.25	18.03	6.26	15.70
2.50	19.59	2.86	14.10
3.86	20.75	0	
5.0	21.46	.61	13.20
7.5	22.66	1.91	13.10
10	23.45	3.14	13.20
15	24.61	5.46	13.70
20	25.12	7.39	14.20
30	24.90	10.10	15.20
40	23.45	11.25	15.20
50	21.19	11.31	14.40
60	18.24	10.48	12.80
70	14.69	8.74	10.47
80	10.38	6.40	7.65
90	5.44	3.53	3.85
100	0	0	0



Figure 2.- Cross section and ordinates of wing with slat.

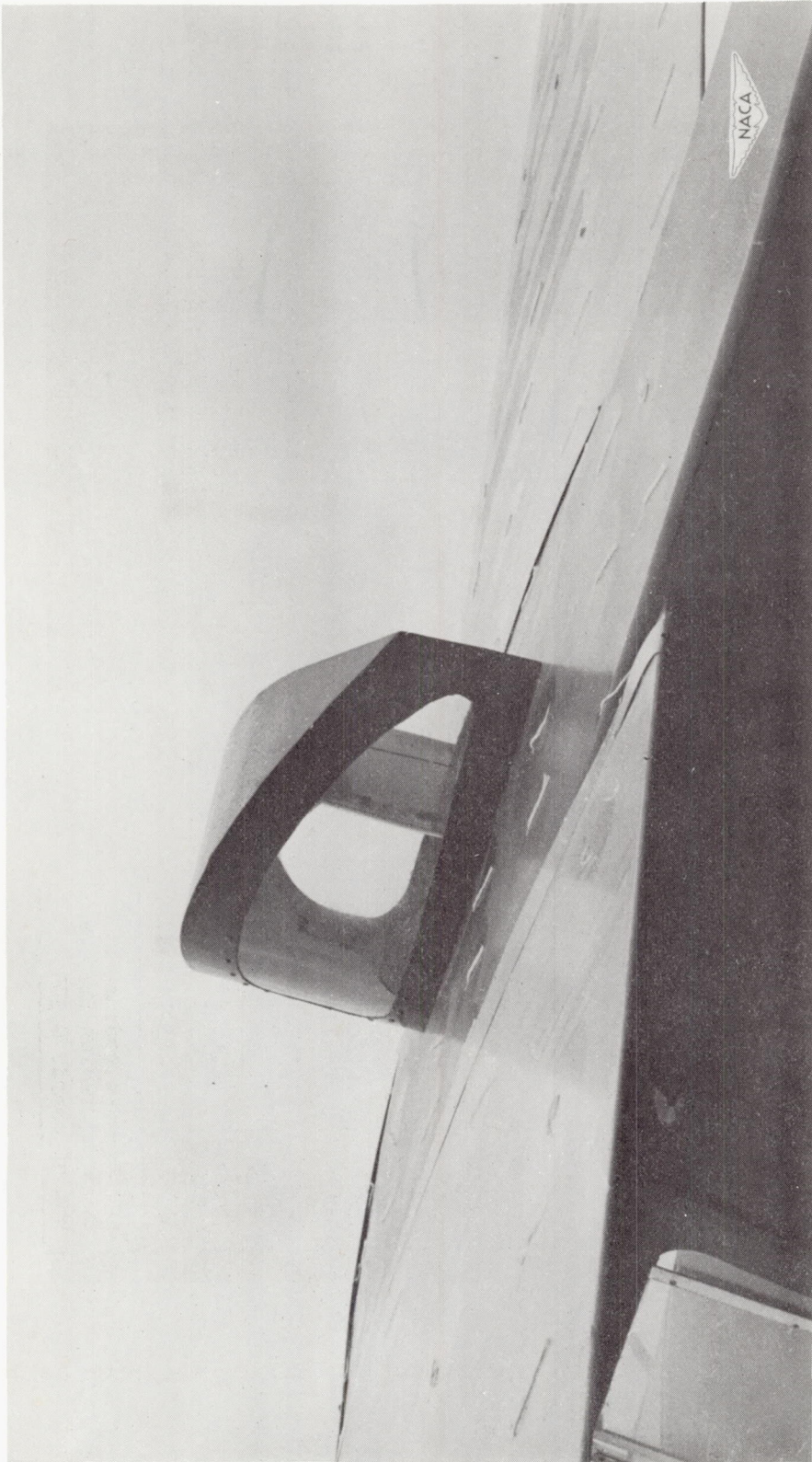

Figure 3.- Dome for tuft observation.

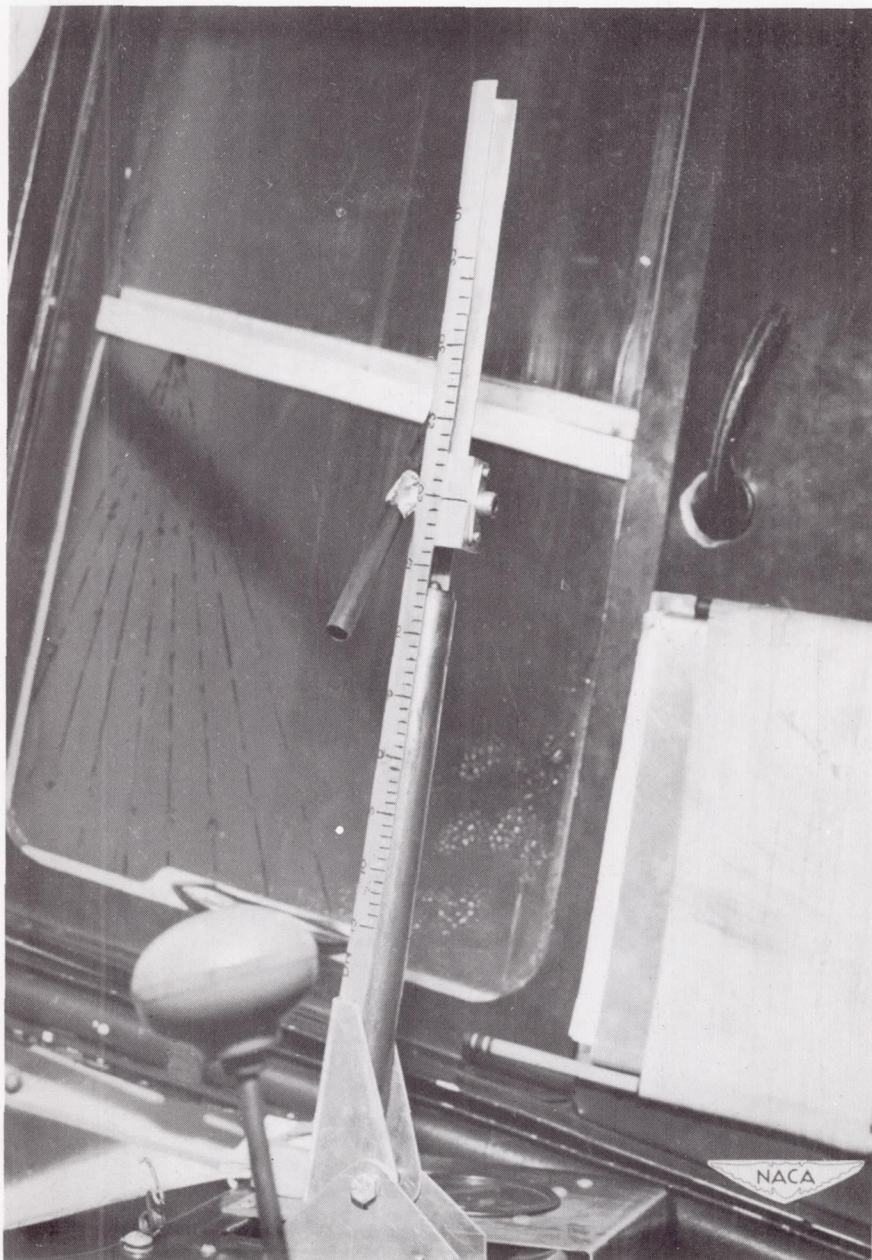

Figure 4.- Cabin view showing instrument for fixing elevator deflection.

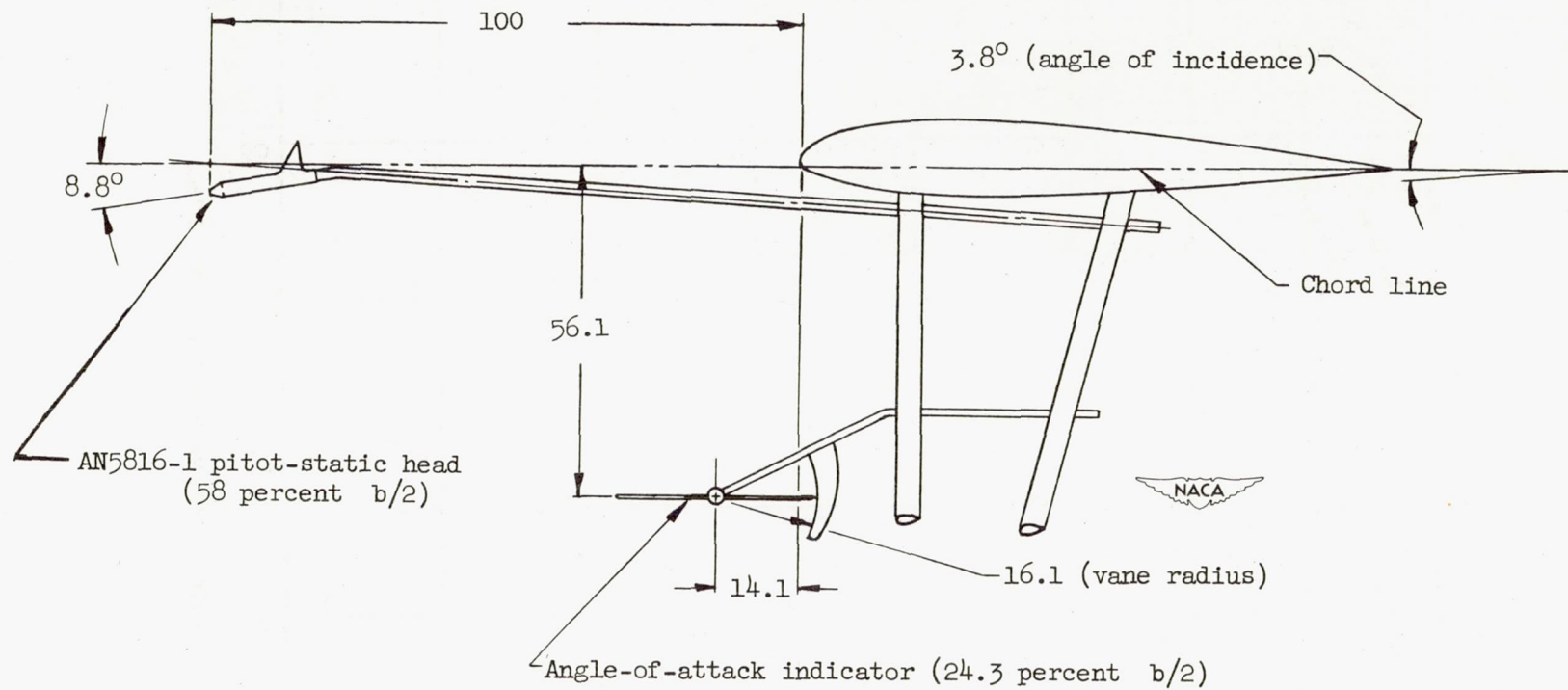

Figure 5.- Location of pitot-static head and angle-of-attack indicator.
Dimensions in percent of chord.

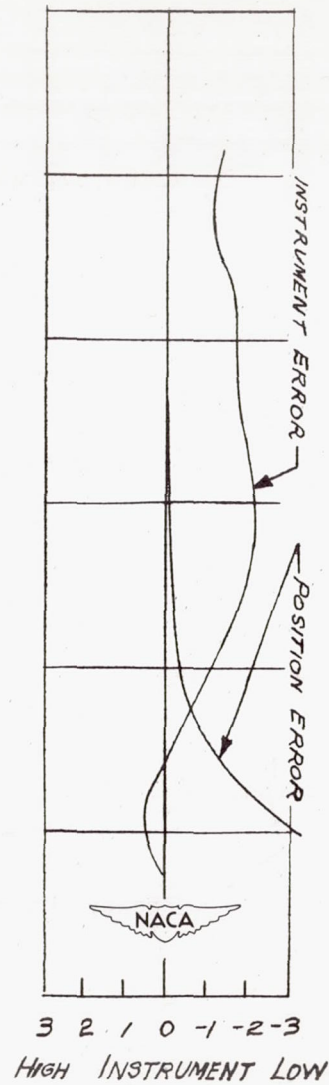
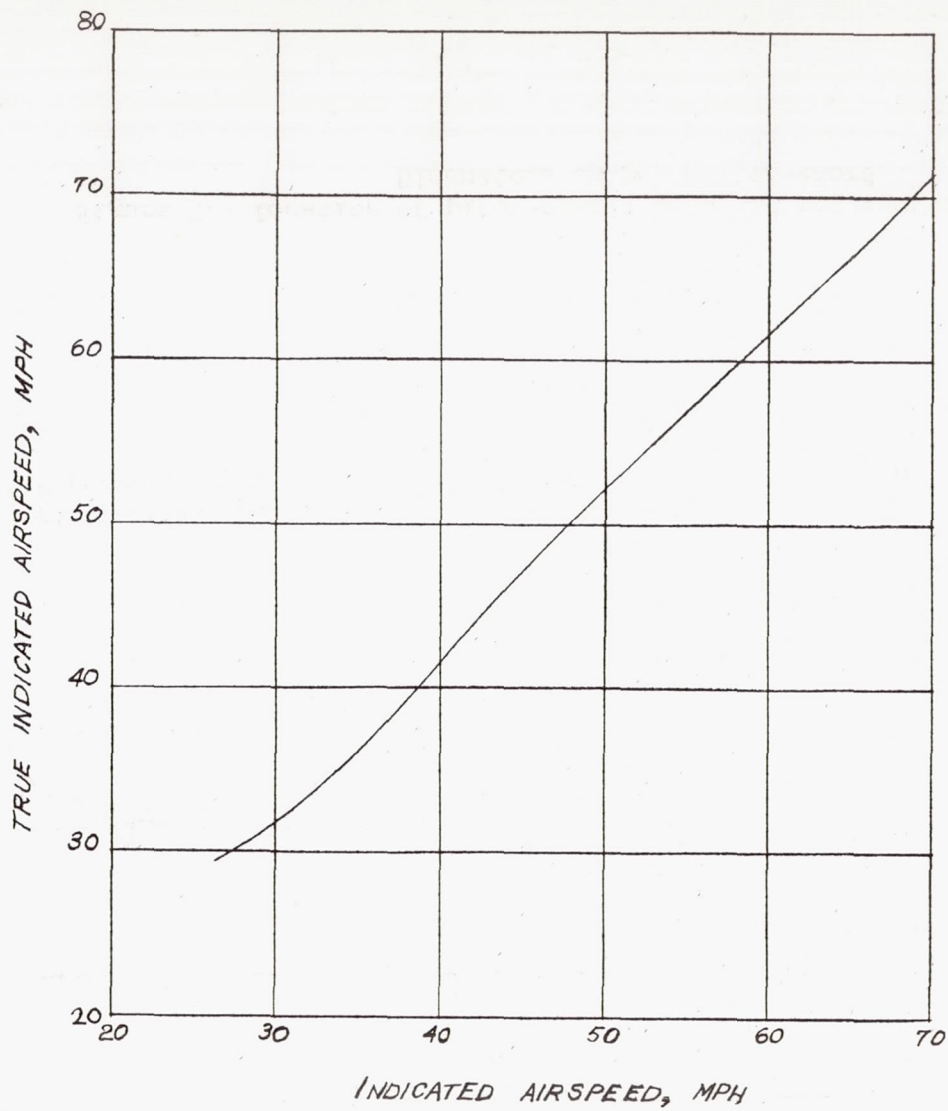

Figure 6.- Airspeed calibration.

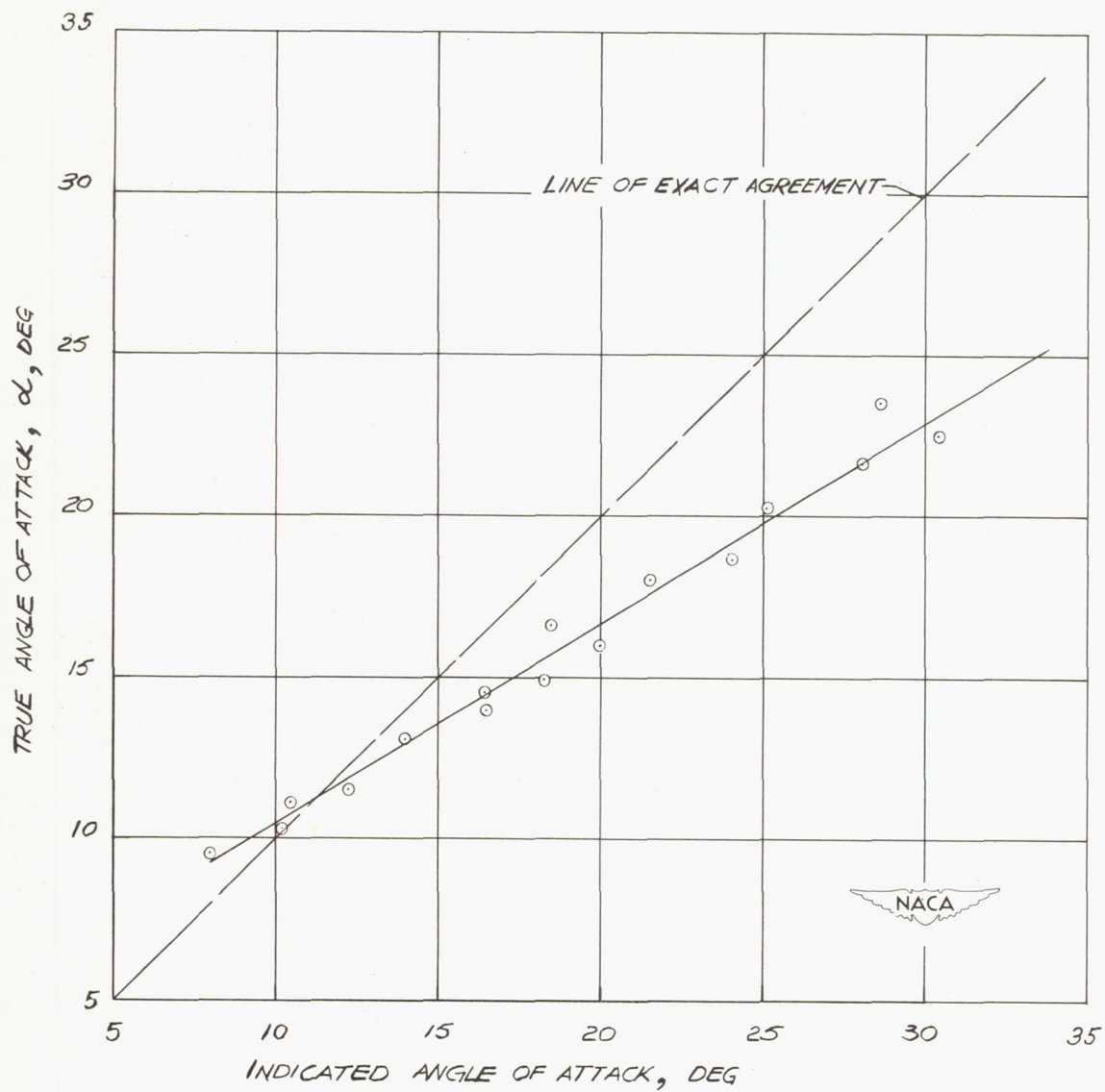

Figure 7.- Angle-of-attack-indicator calibration.

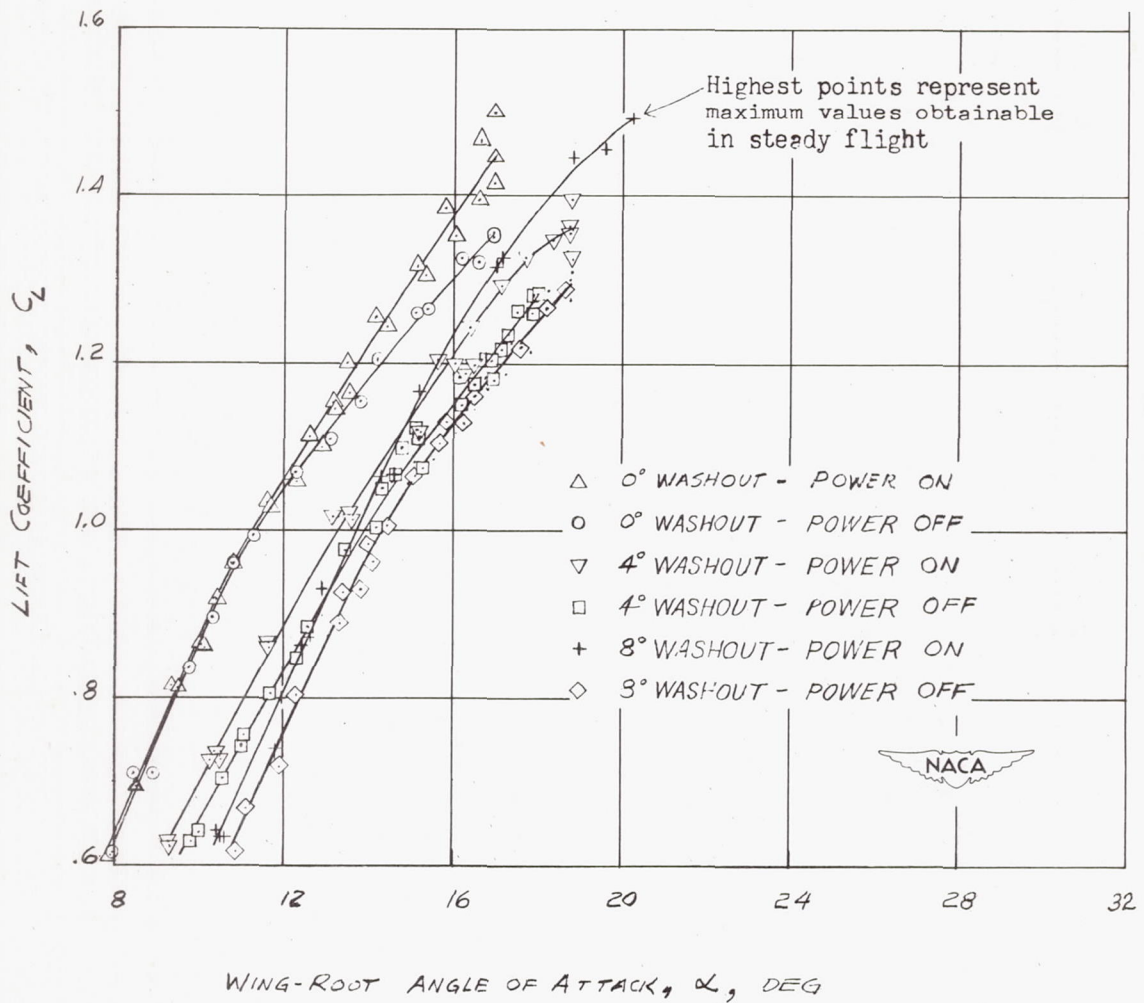
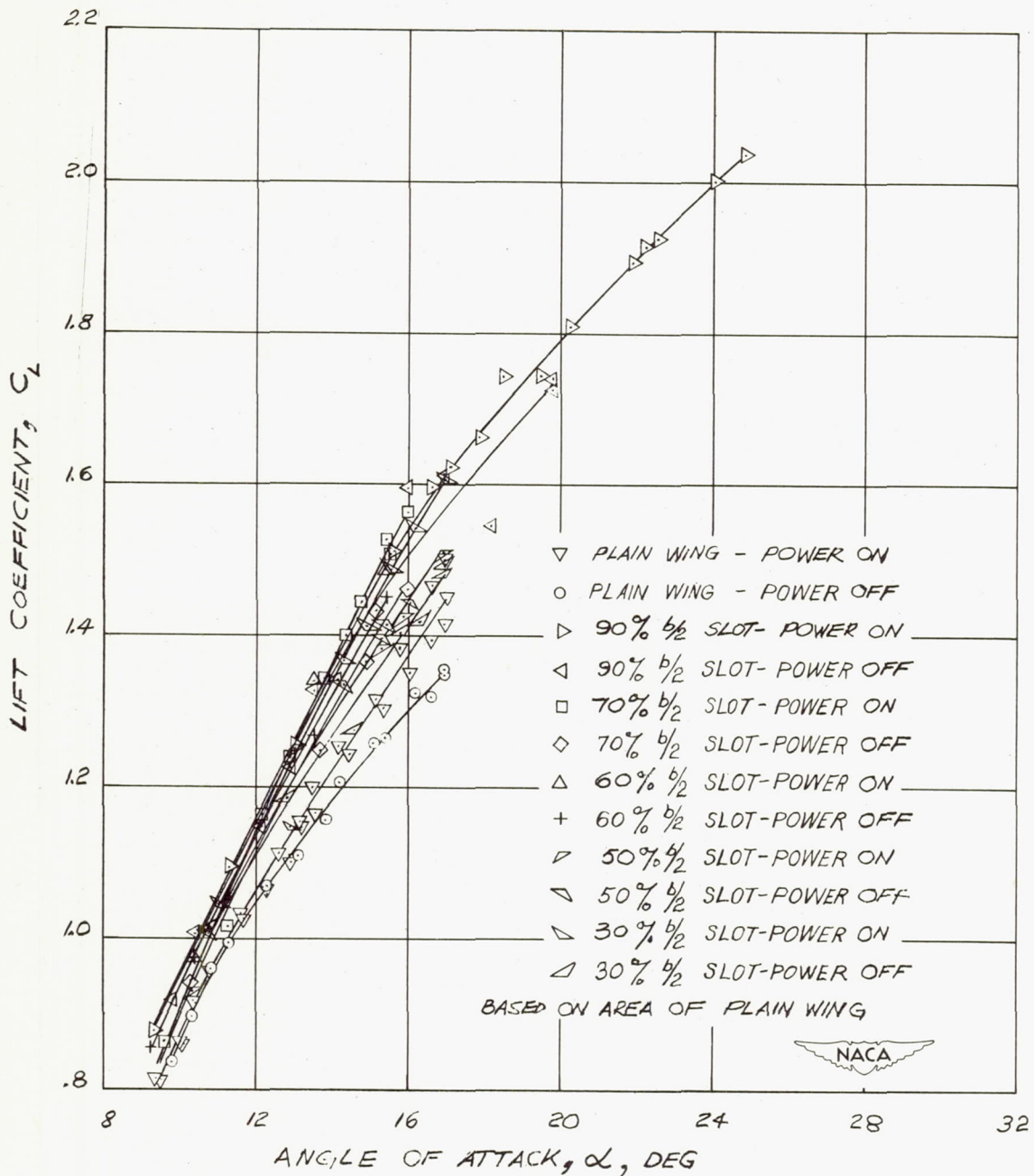
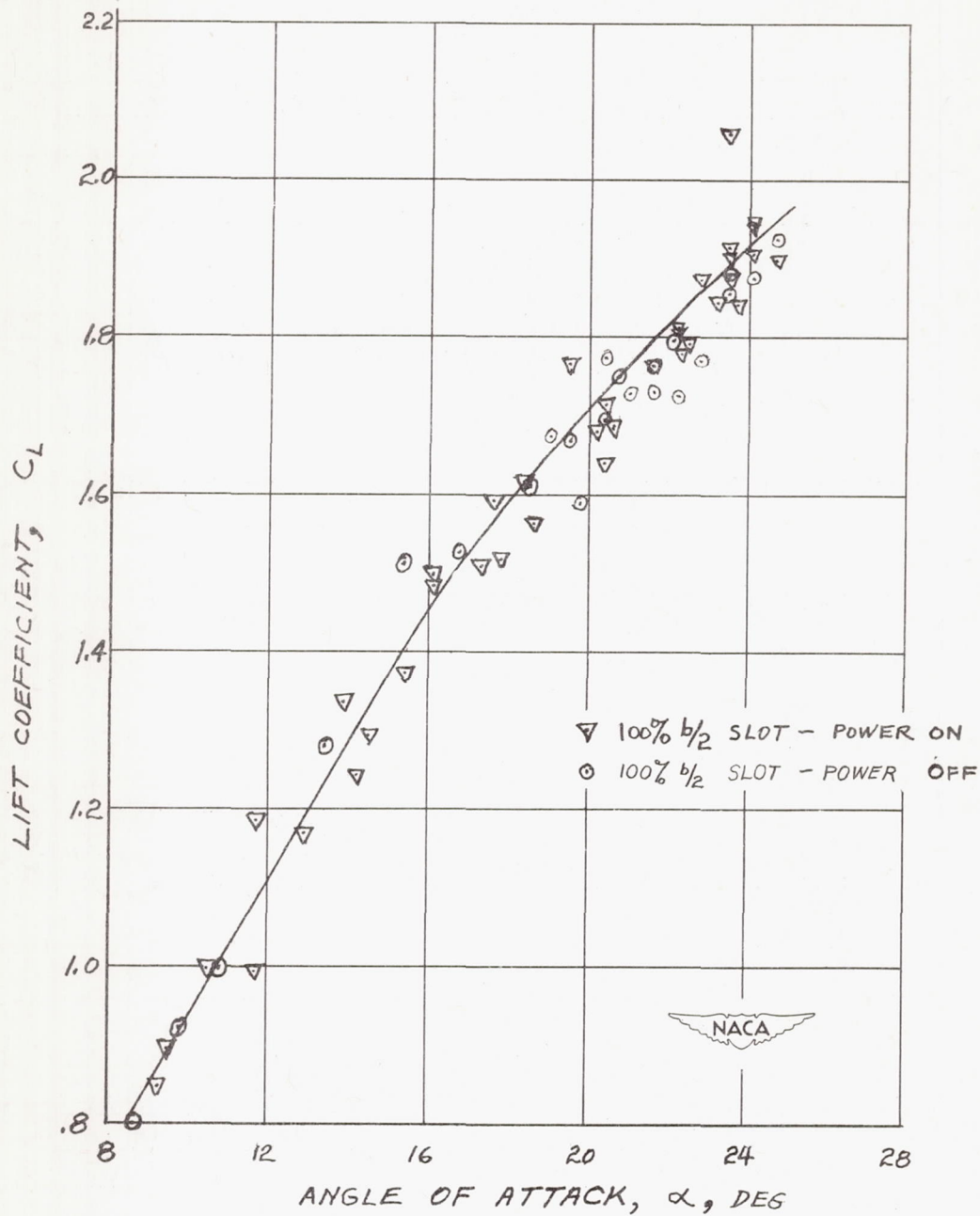

Figure 8.- Airplane lift characteristics for 0°, 4°, and 8° of washout.



(a) Inboard end of slot at 0, 30, 50, 60, 70, and 90 percent $b/2$ from tips.

Figure 9.- Airplane lift characteristics for slotted configurations.



(b) Full-span slot.

Figure 9.- Concluded.

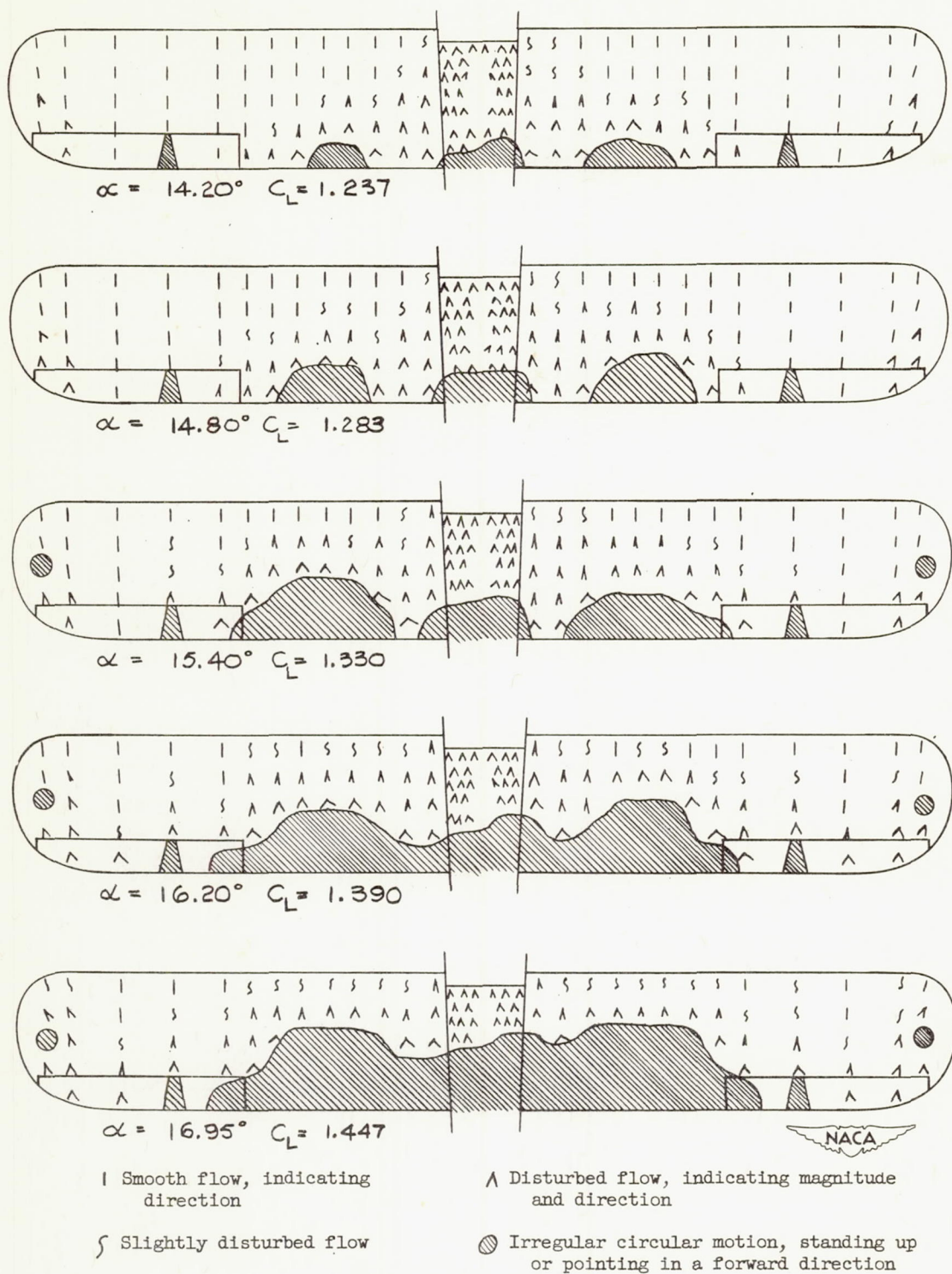

(a) Full throttle.

Figure 10.- Stall progression on plain untwisted wing.

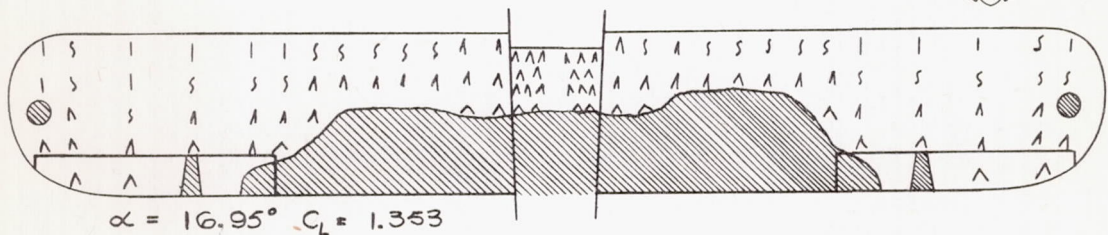
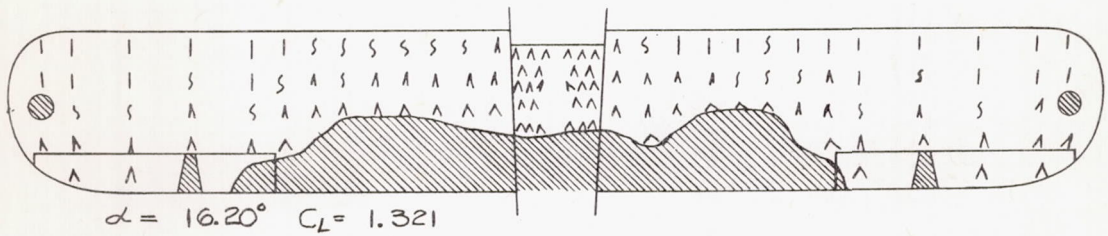
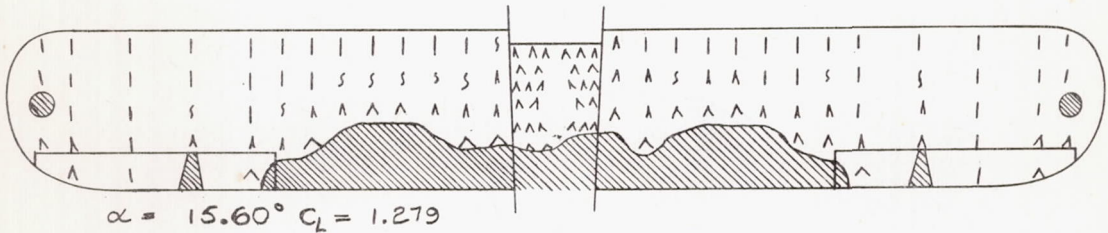
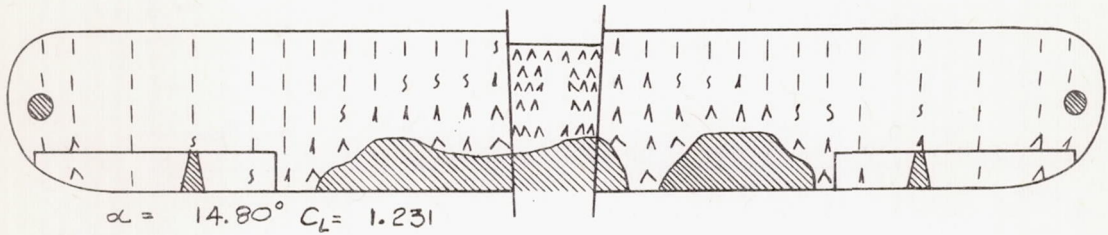
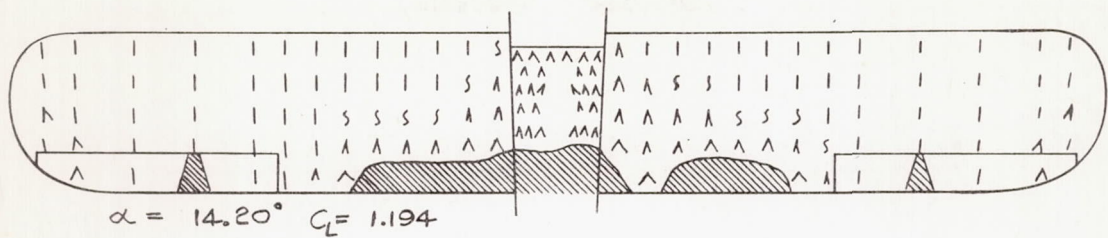

| Smooth flow, indicating direction

{ Slightly disturbed flow

^ Disturbed flow, indicating magnitude and direction

⊙ Irregular circular motion, standing up or pointing in a forward direction

(b) Engine idling.

Figure 10.- Concluded.

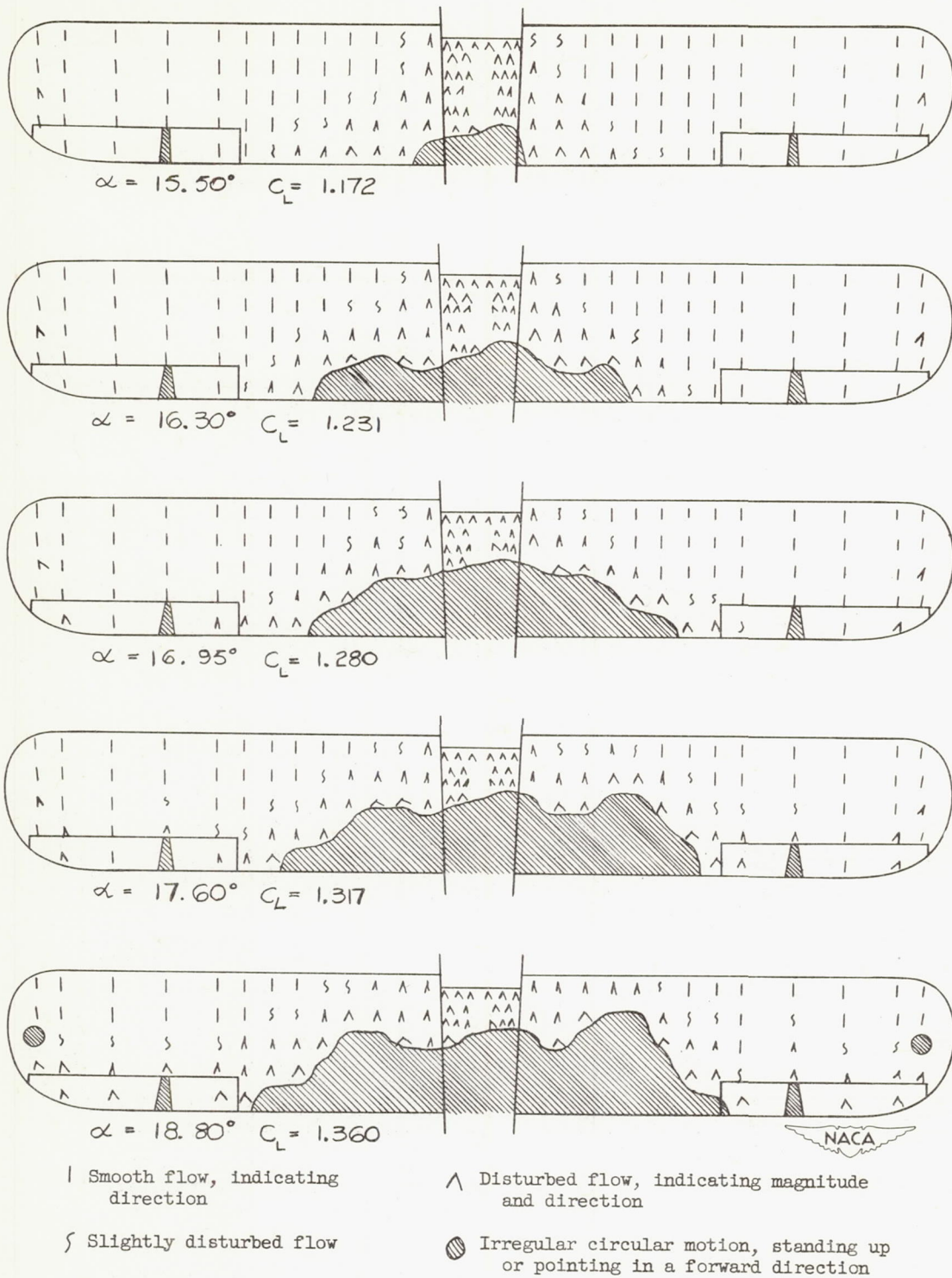

(a) Full throttle.

Figure 11.- Stall progression on wing with 4° of washout at tips.

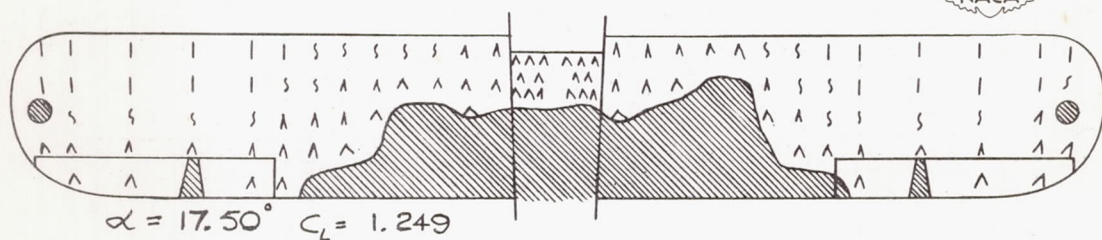
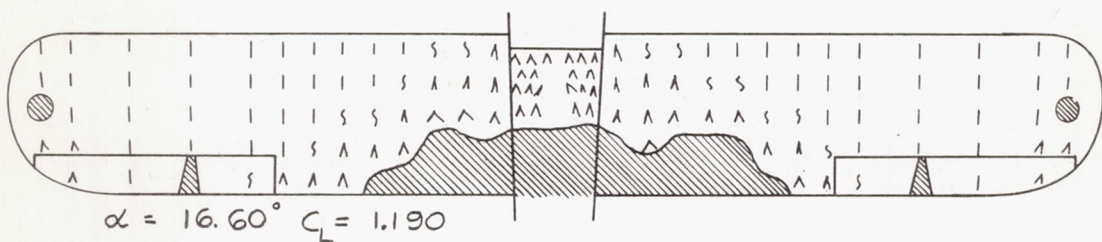
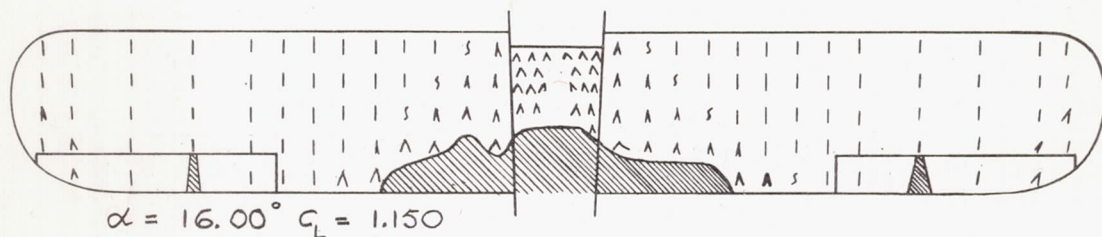
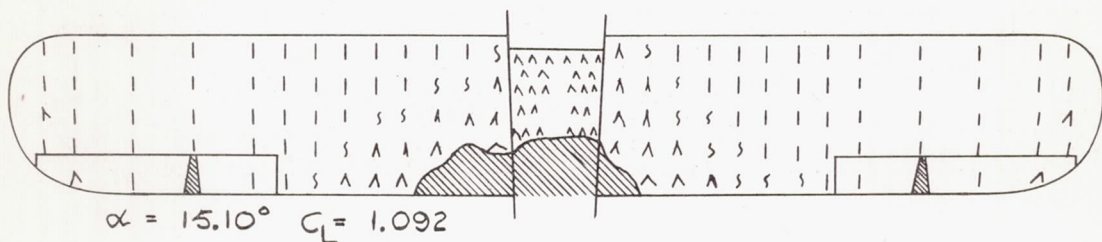
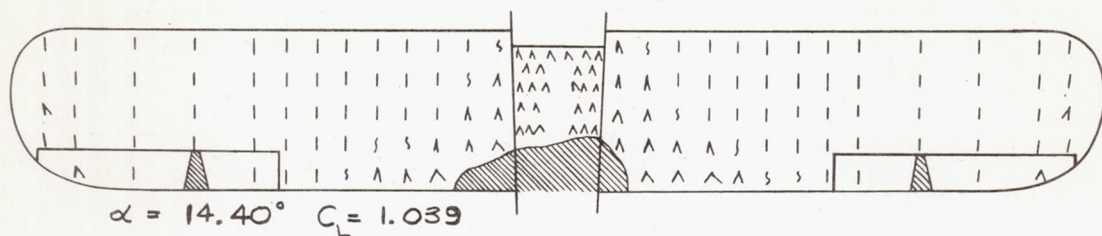

| Smooth flow, indicating direction

^ Disturbed flow, indicating magnitude and direction

∫ Slightly disturbed flow

⊙ Irregular circular motion, standing up or pointing in a forward direction

(b) Engine idling.

Figure 11.- Concluded.

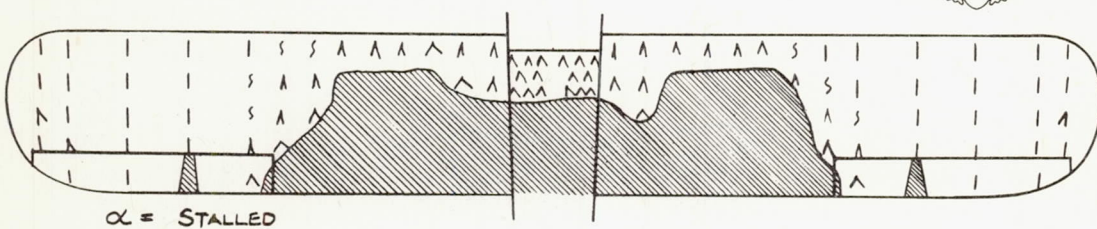
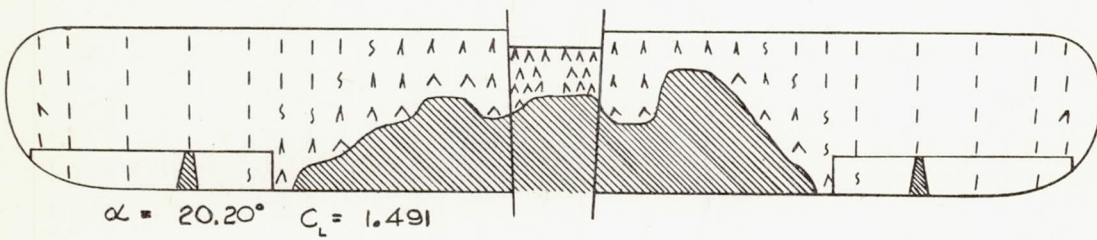
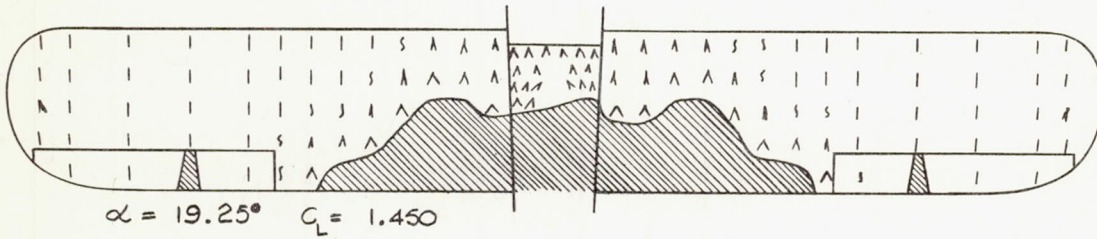
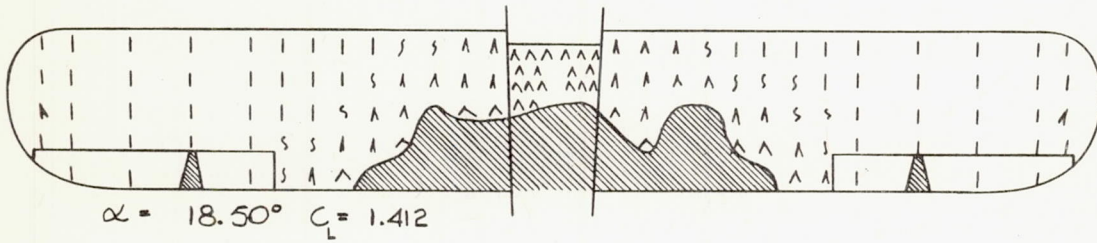
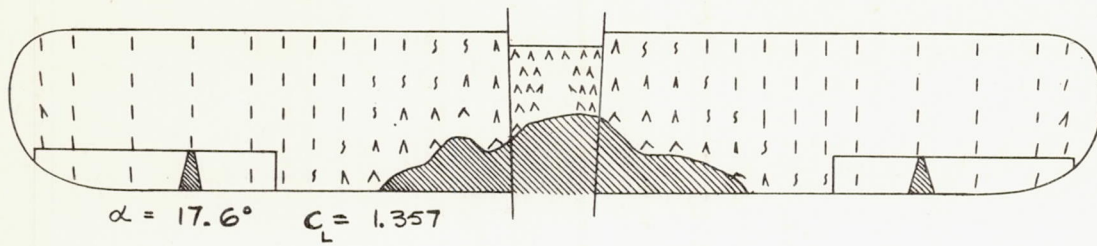

| Smooth flow, indicating direction

^ Disturbed flow, indicating magnitude and direction

{ Slightly disturbed flow

⊙ Irregular circular motion, standing up or pointing in a forward direction

(a) Full throttle.

Figure 12.- Stall progression on wing with 8° of washout at tips.

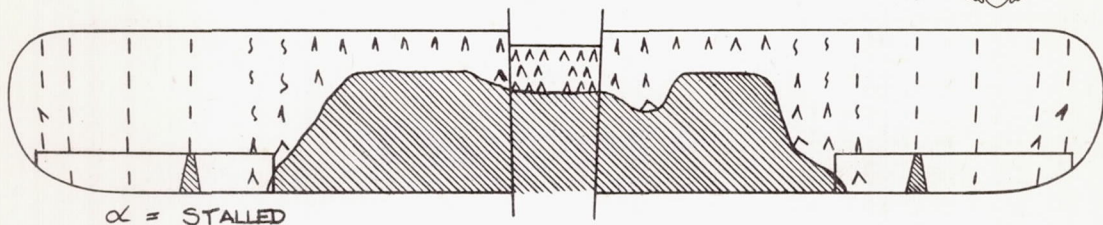
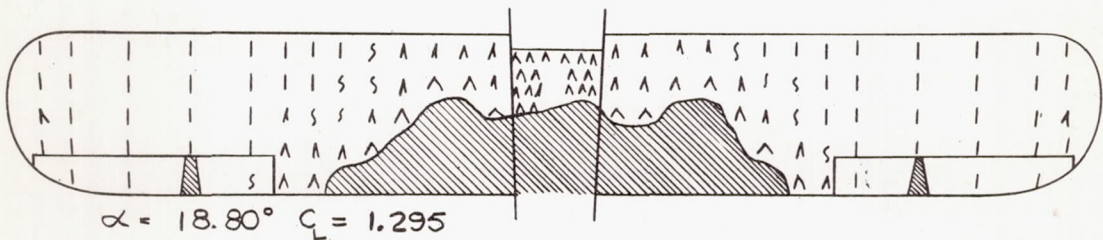
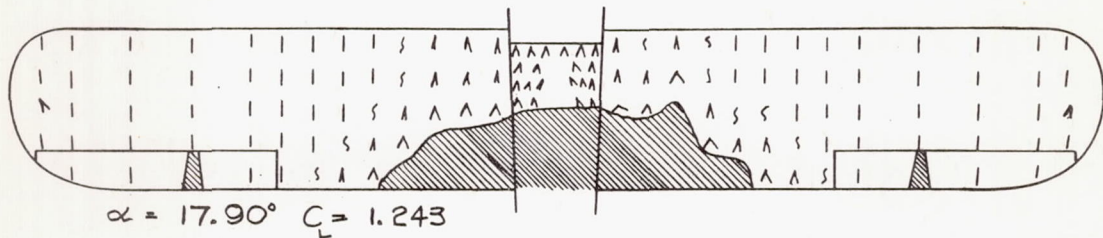
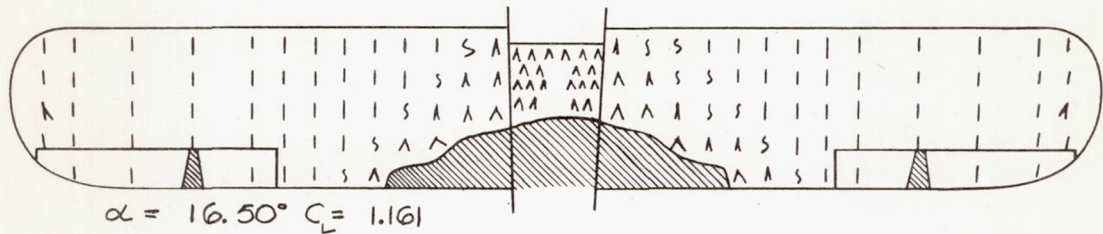
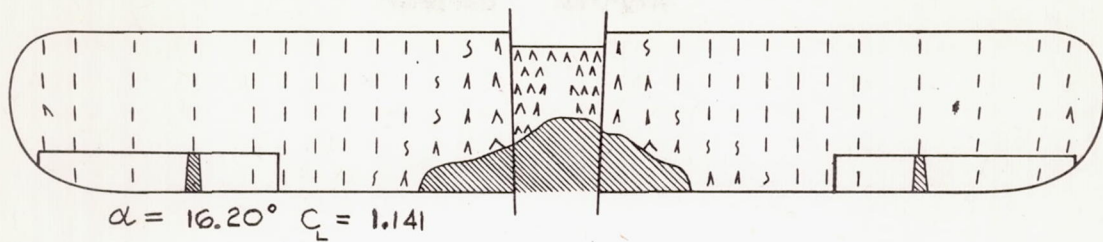

- | Smooth flow, indicating direction
- ∧ Disturbed flow, indicating magnitude and direction
- ∫ Slightly disturbed flow
- ⊙ Irregular circular motion, standing up or pointing in a forward direction

(b) Engine idling.

Figure 12.- Concluded.

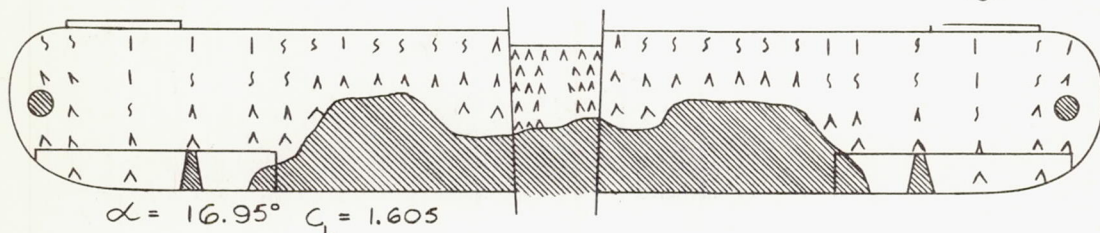
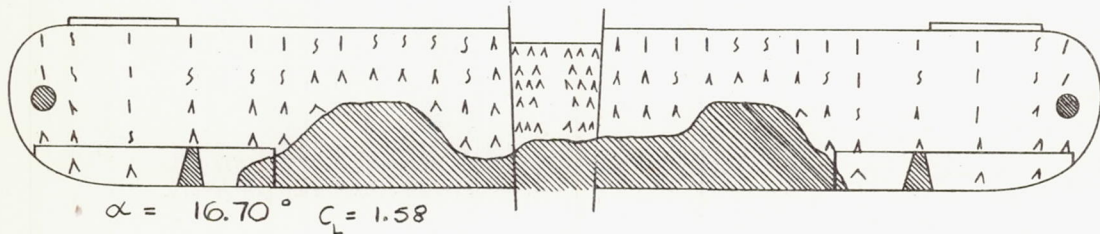
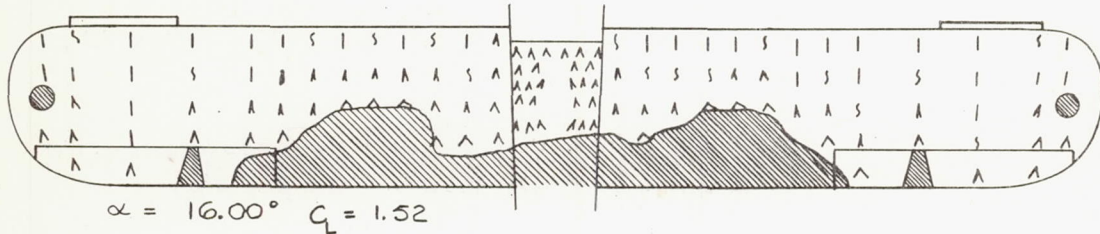
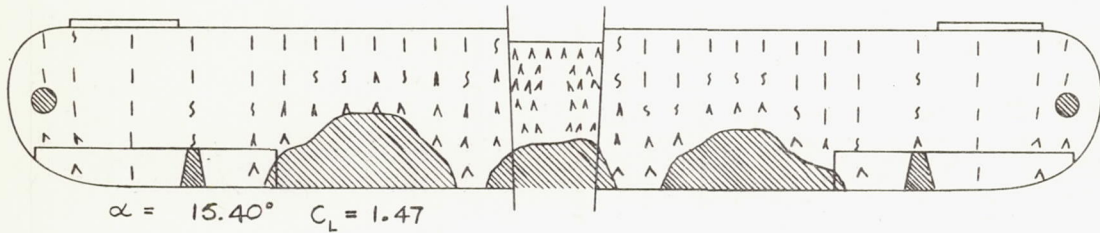
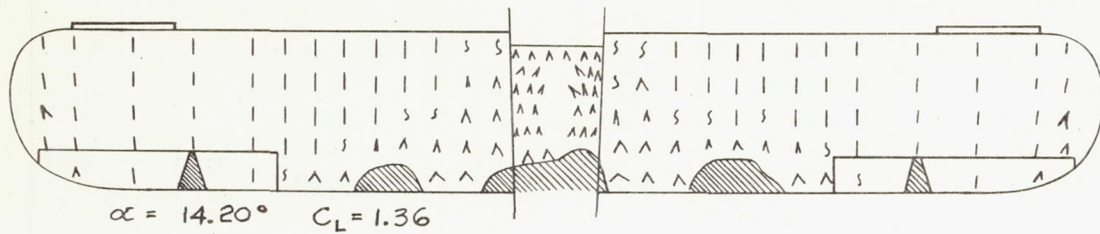

| Smooth flow, indicating direction

{ Slightly disturbed flow

^ Disturbed flow, indicating magnitude and direction

● Irregular circular motion, standing up or pointing in a forward direction

NACA

(a) Full throttle.

Figure 13.- Stall progression on slotted wing with inboard end of slot 30 percent $b/2$ from tip.

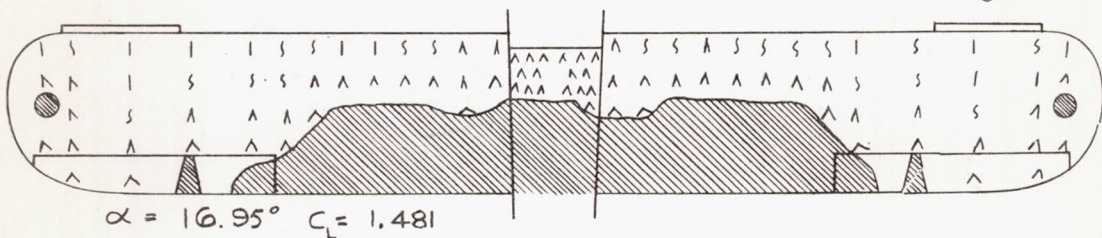
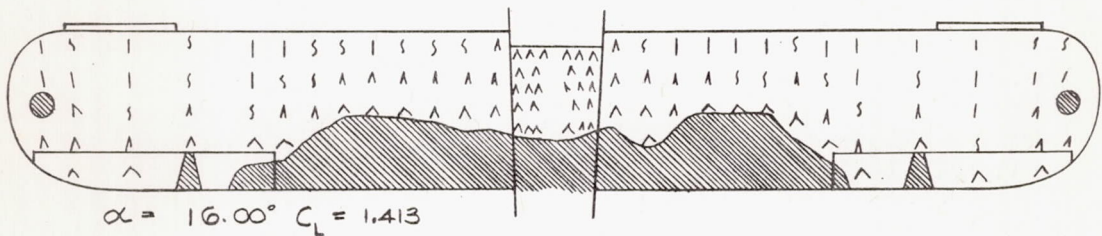
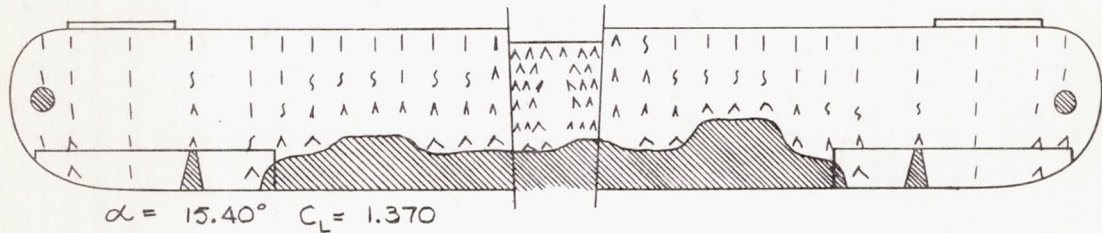
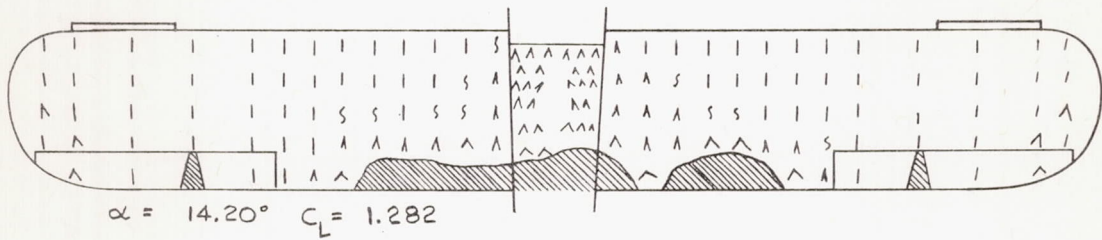
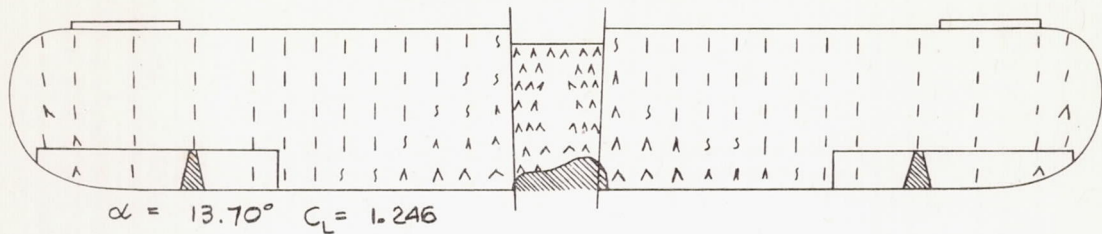

- | | | | |
|---|-----------------------------------|---|---|
| | Smooth flow, indicating direction | ^ | Disturbed flow, indicating magnitude and direction |
| ∫ | Slightly disturbed flow | ⊙ | Irregular circular motion, standing up or pointing in a forward direction |

(b) Engine idling.

Figure 13.- Concluded.

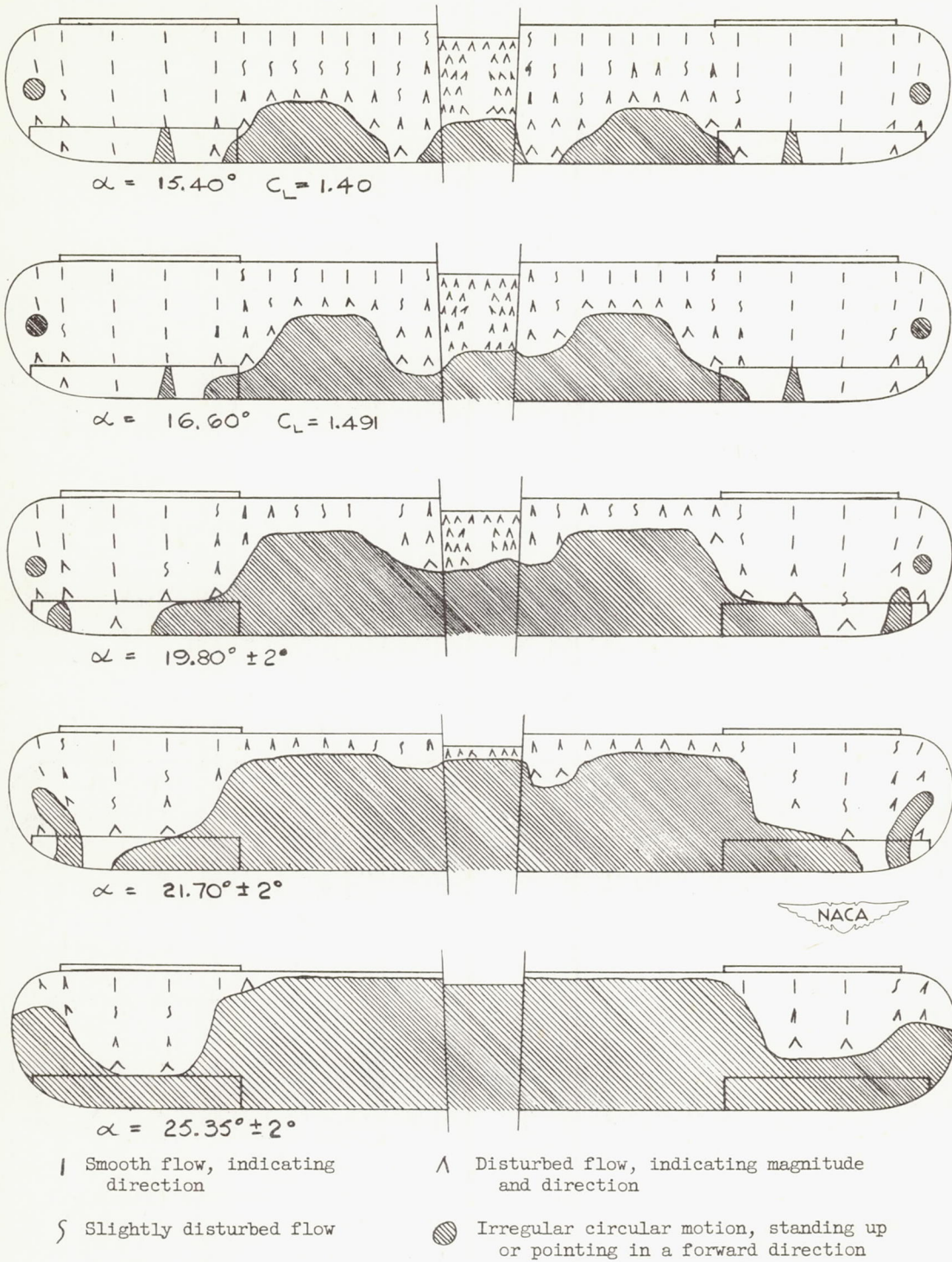

(a) Full throttle.

Figure 14.- Stall progression on slotted wing with inboard end of slot 50 percent $b/2$ from tip.

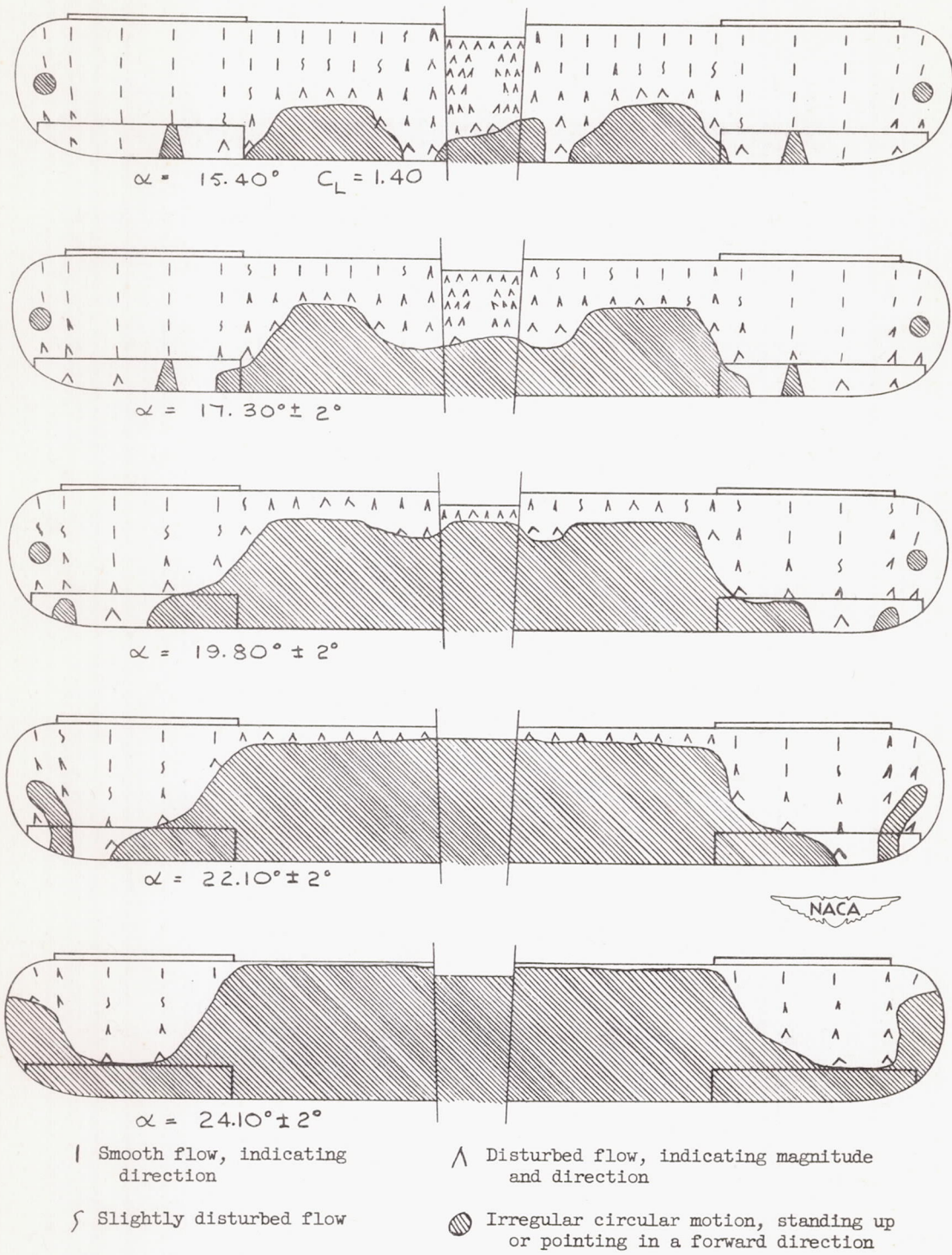

(b) Engine idling.

Figure 14.- Concluded.

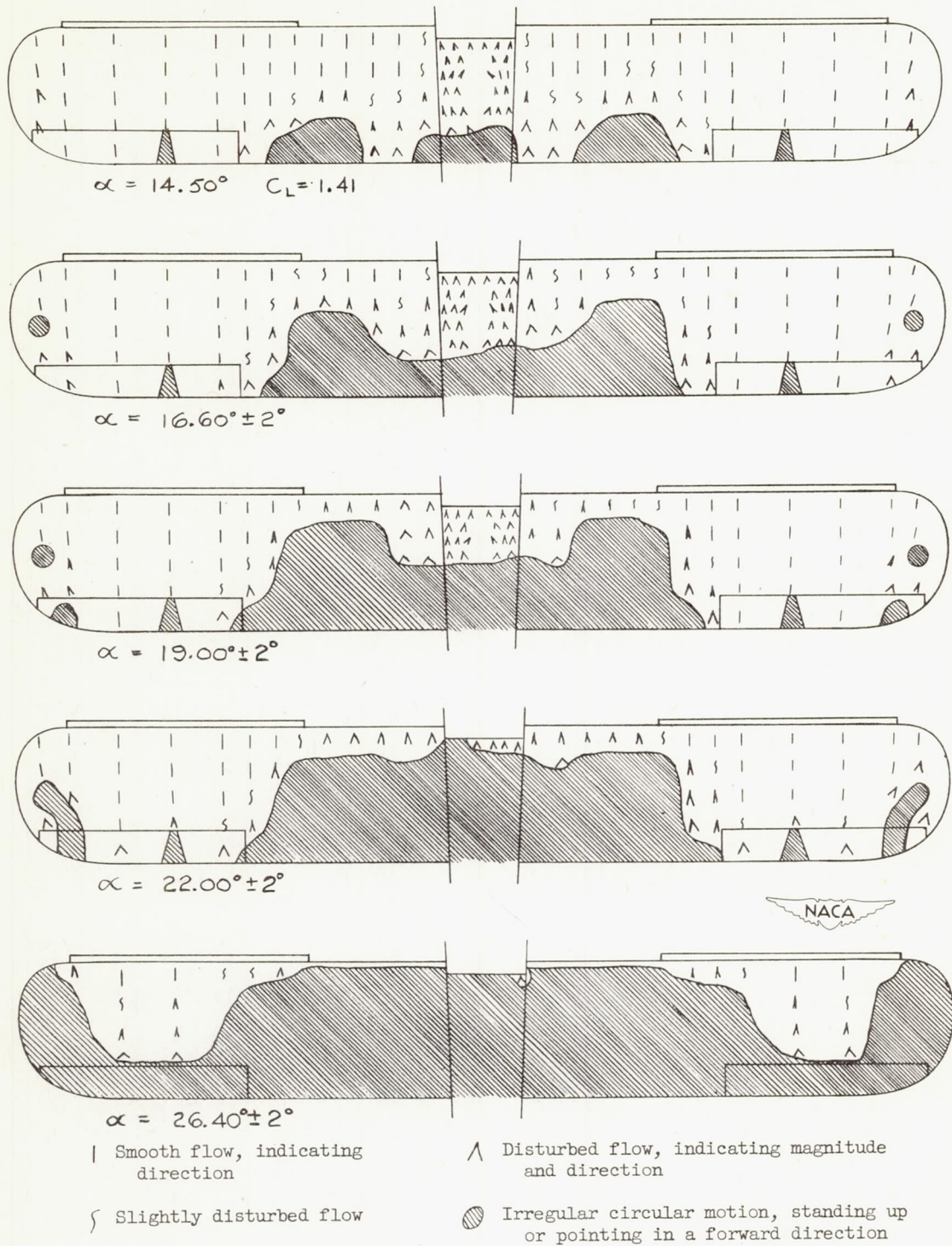

(a) Full throttle.

Figure 15.- Stall progression on slotted wing with inboard end of slot 60 percent $b/2$ from tip.

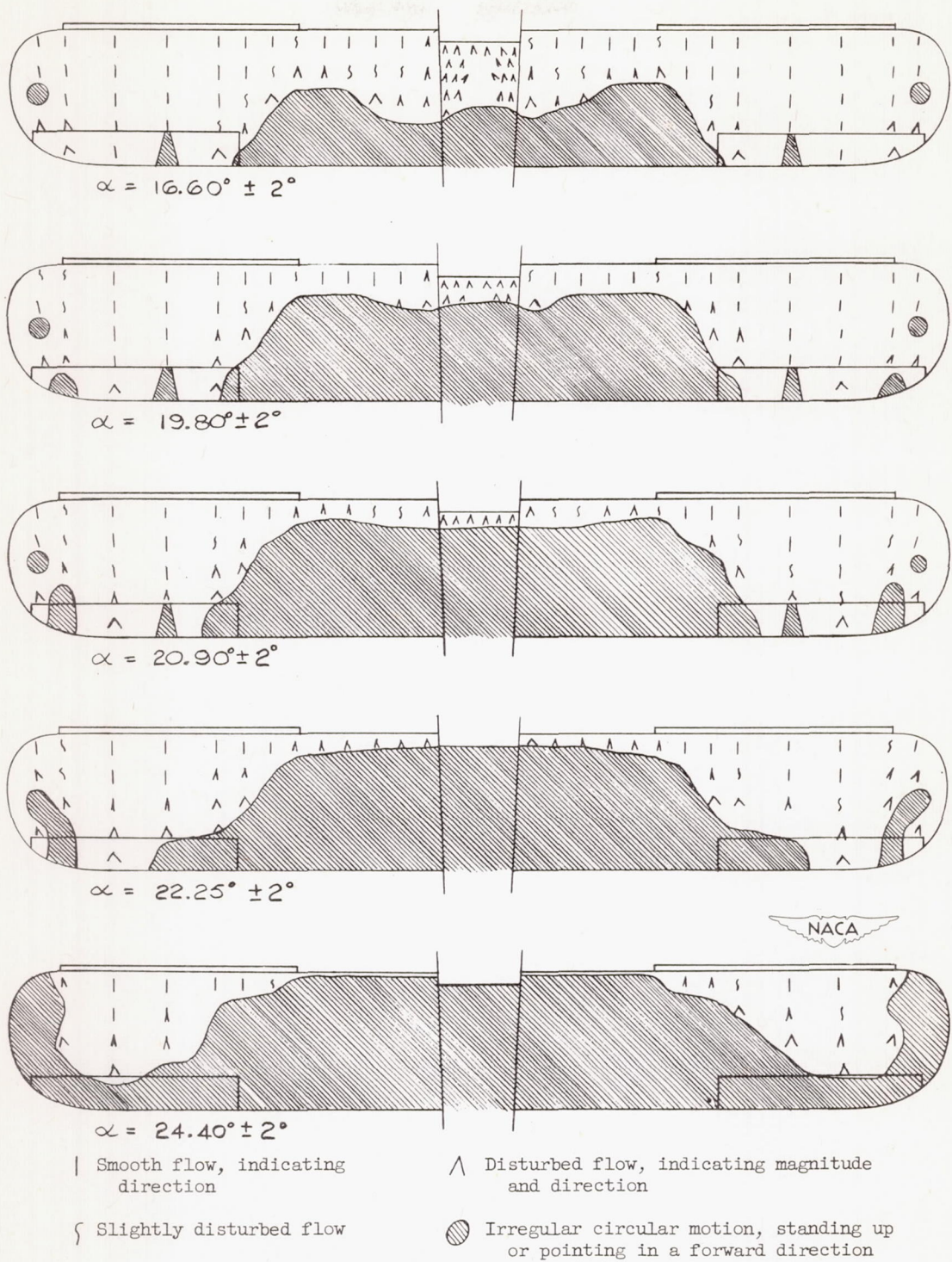

(b) Engine idling.

Figure 15.- Concluded.

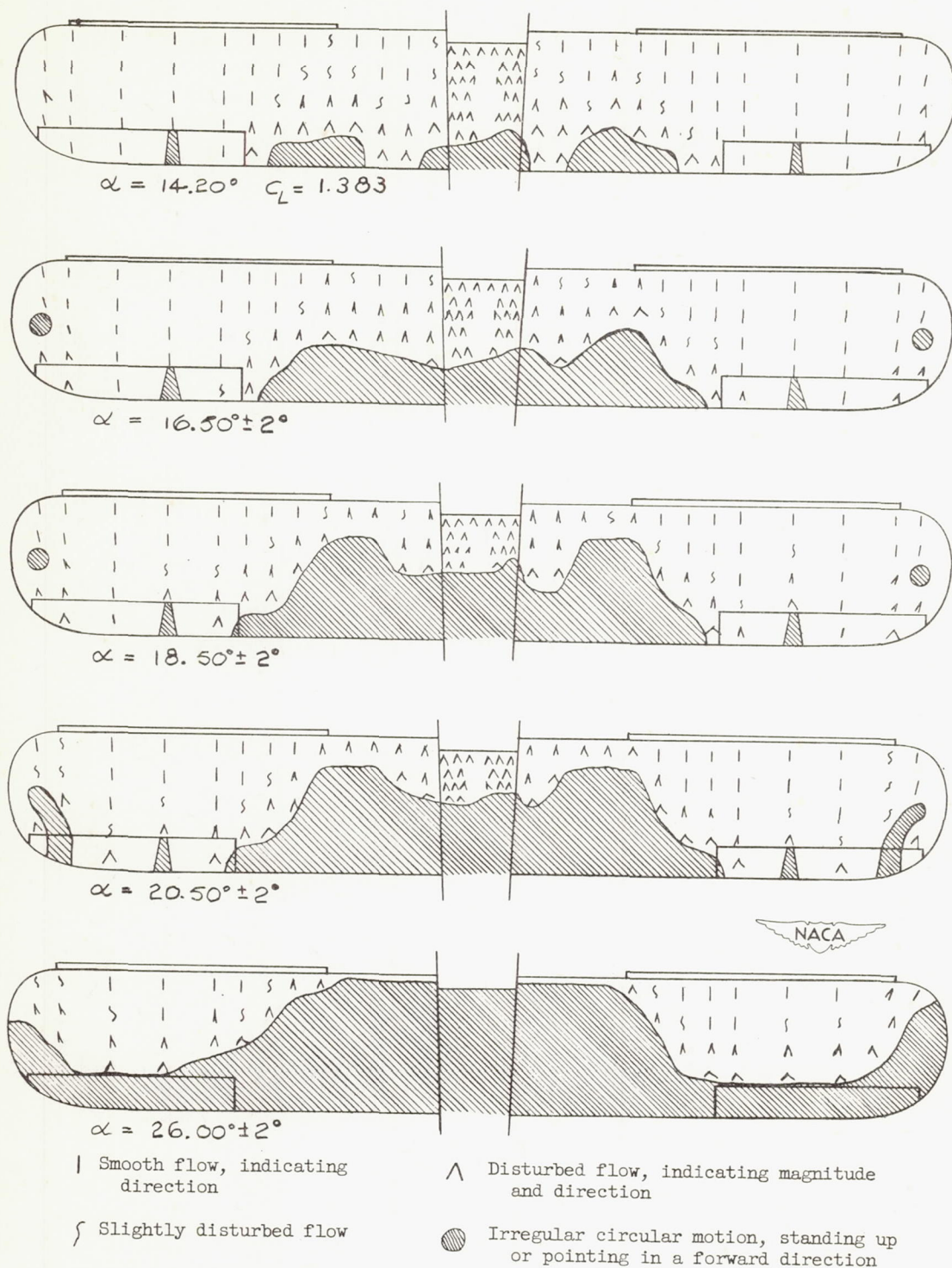

(a) Full throttle.

Figure 16.- Stall progression on slotted wing with inboard end of slot 70 percent $b/2$ from tip.

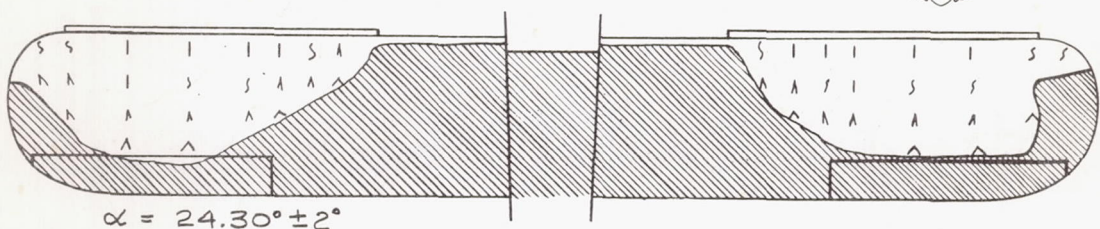
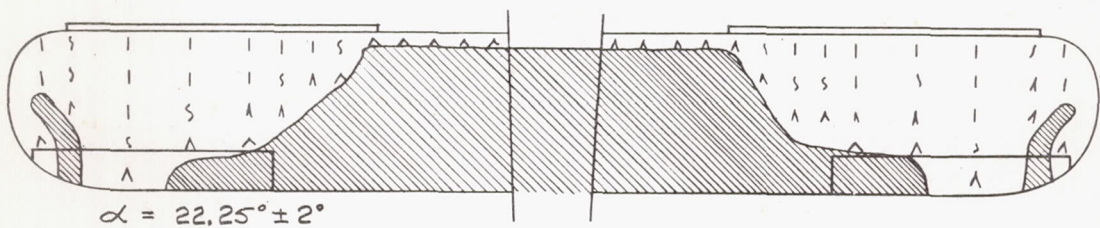
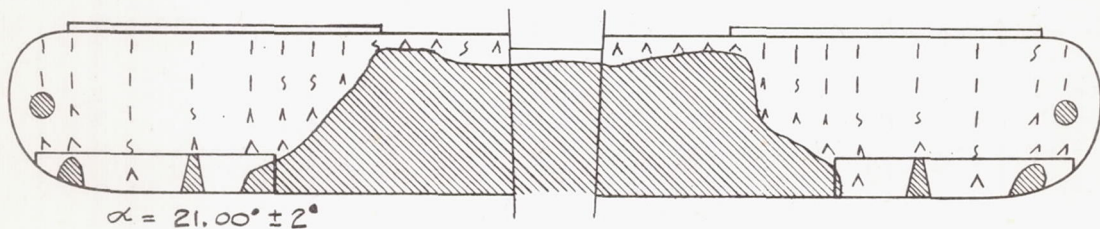
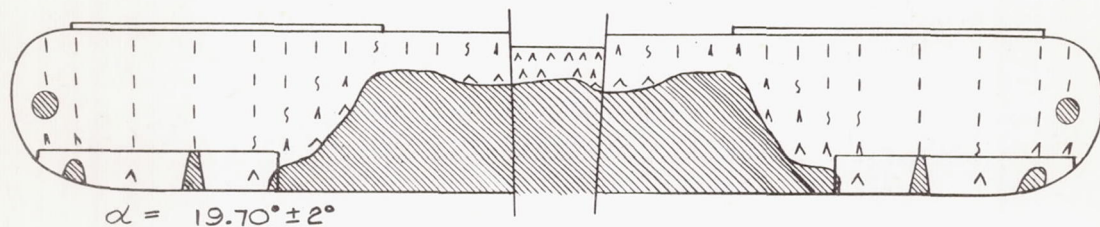
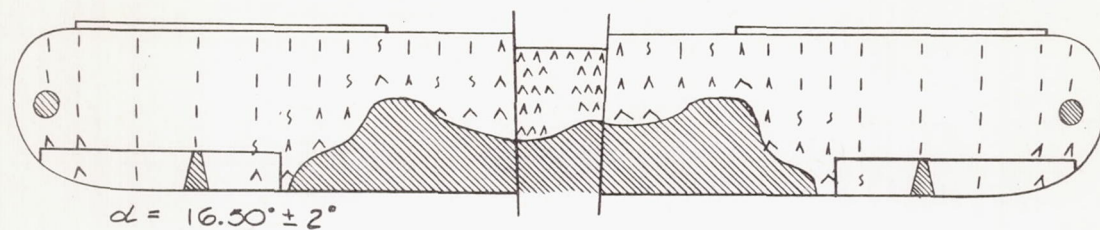

- | | |
|-----------------------------------|---|
| Smooth flow, indicating direction | △ Disturbed flow, indicating magnitude and direction |
| ∩ Slightly disturbed flow | ⊙ Irregular circular motion, standing up or pointing in a forward direction |

(b) Engine idling.

Figure 16.- Concluded.

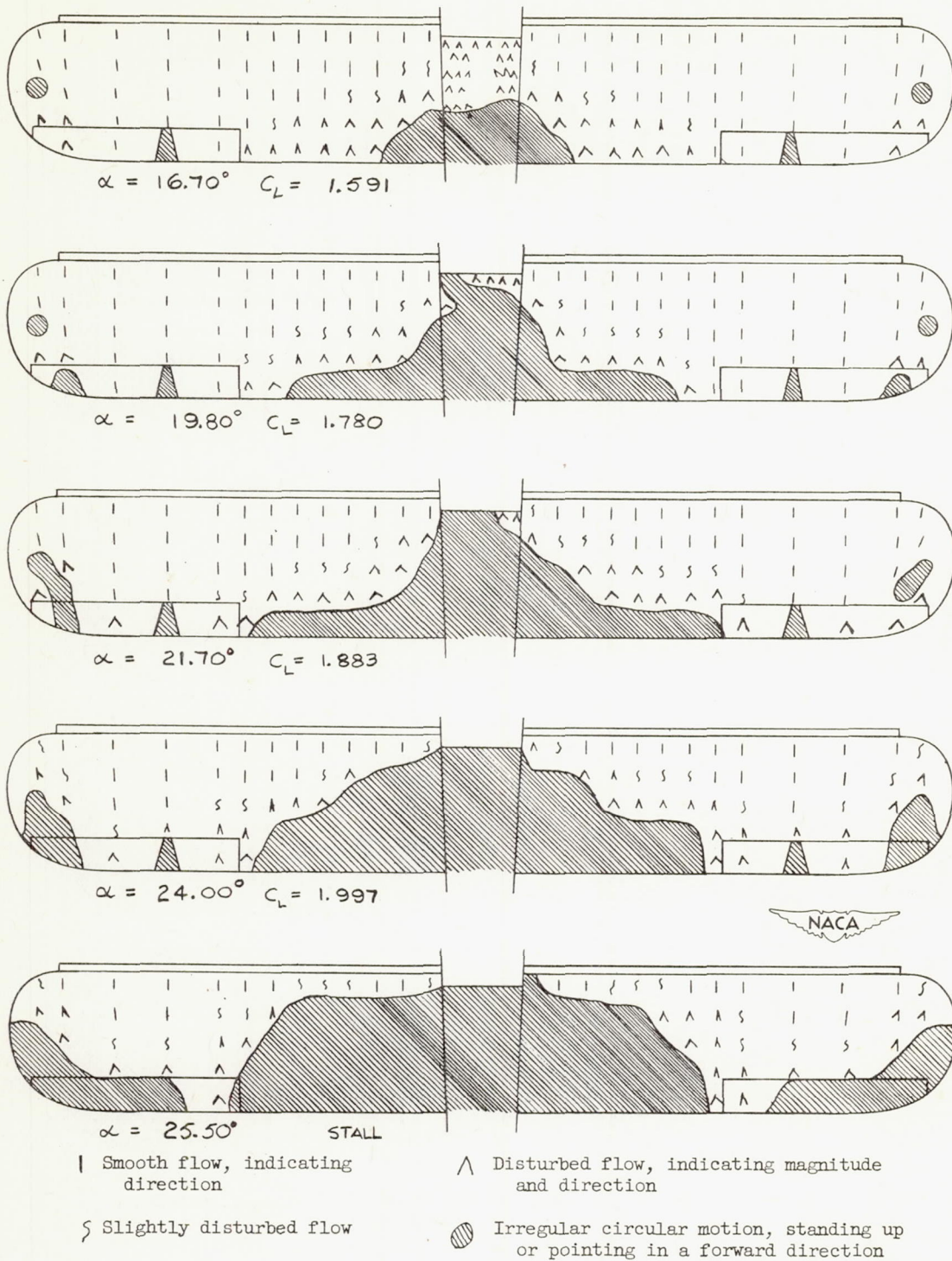

(a) Full throttle.

Figure 17.- Stall progression on slotted wing with inboard end of slot 90 percent $b/2$ from tip.

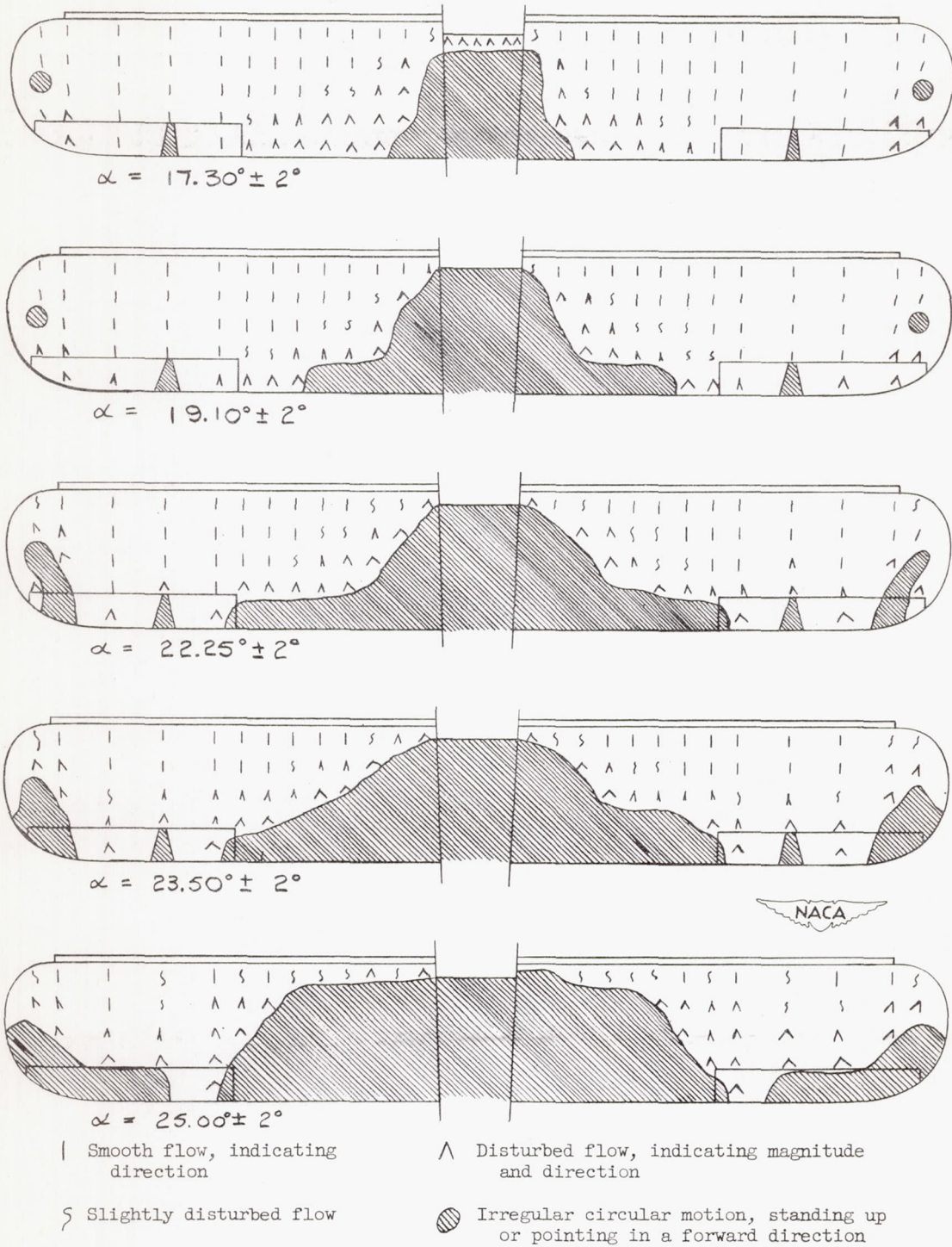

(b) Engine idling.

Figure 17.- Concluded.

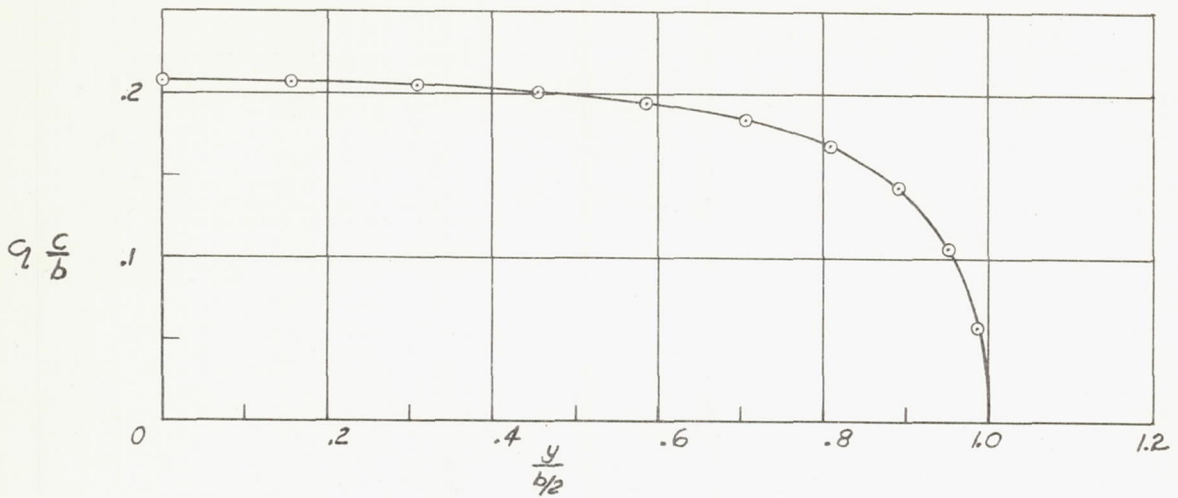

(a) Computed span loading. $\alpha = 16.3^\circ$; $C_L = 1.328$.

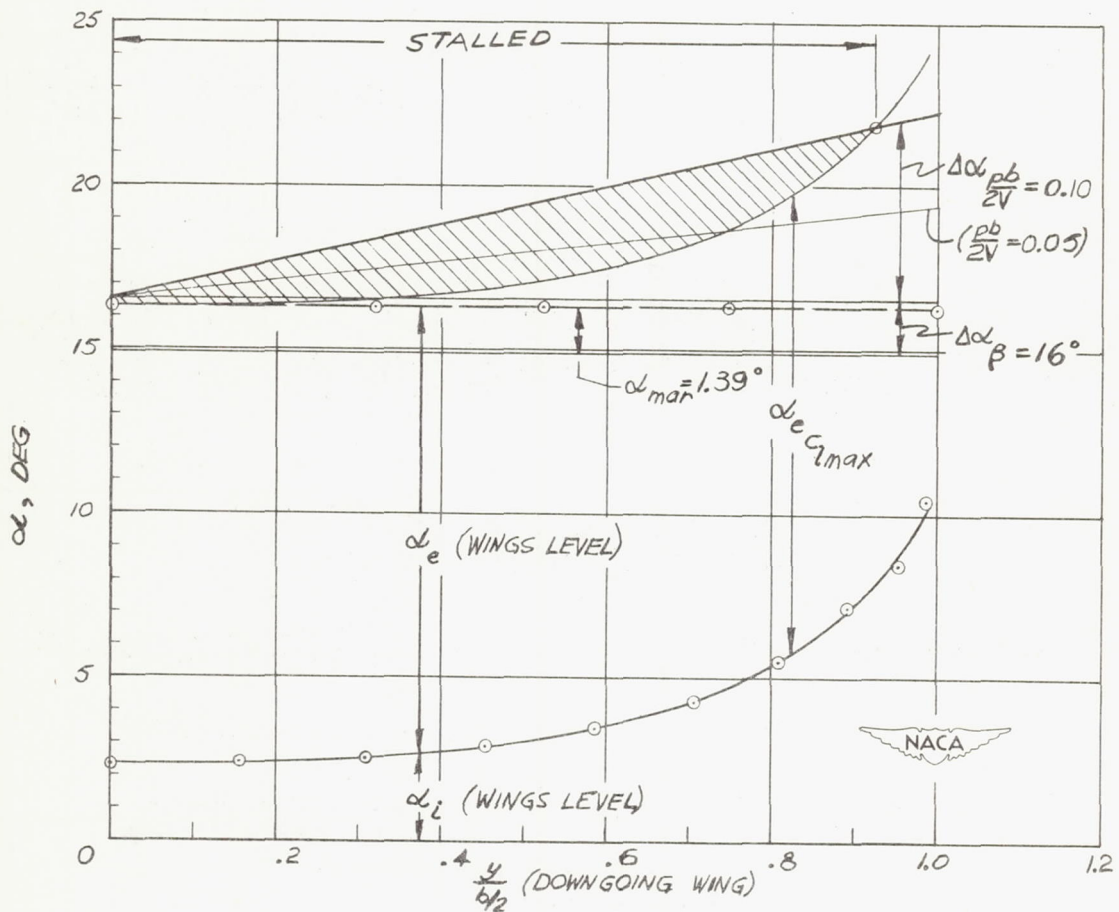

(b) Idealized angle-of-attack redistribution in roll; wind axis fixed.

Figure 18.- Span load and angle-of-attack distribution. Untwisted wing.

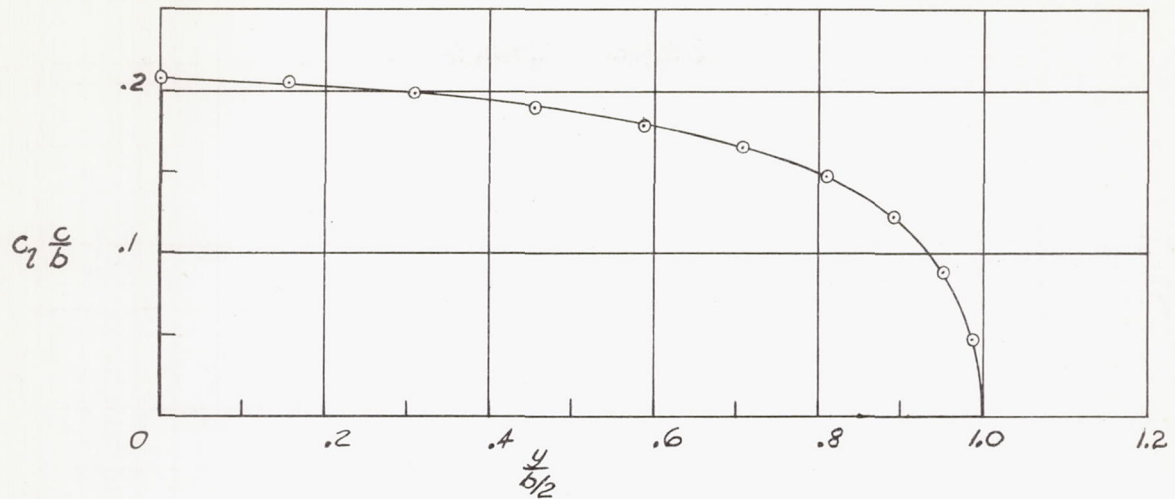

(a) Computed span loading. $\alpha = 16.80^\circ$; $C_L = 1.333$.

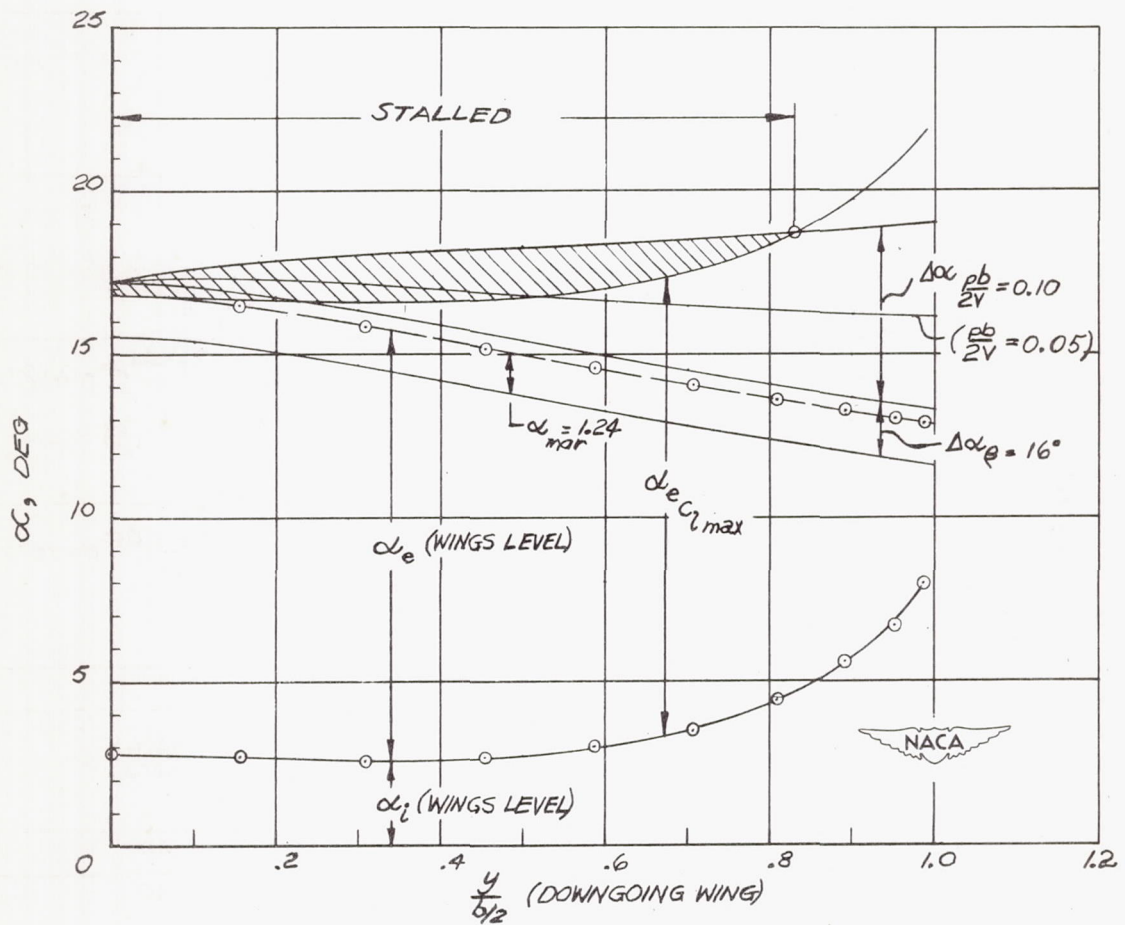

(b) Idealized angle-of-attack redistribution in roll; wind axis fixed.

Figure 19.- Span load and angle-of-attack distribution. 4° of washout.

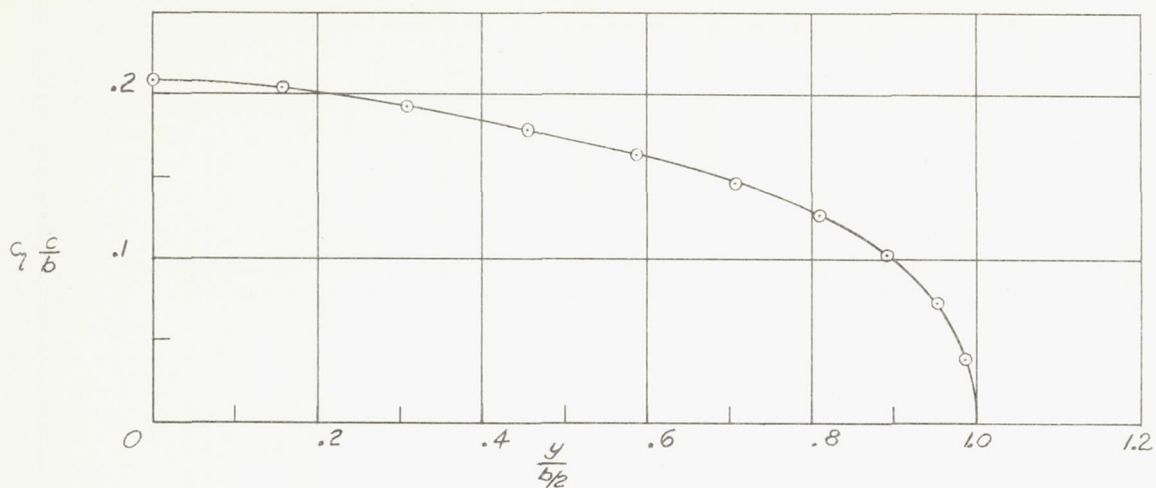

(a) Computed span loading. $\alpha = 17.40^\circ$; $C_L = 1.358$.

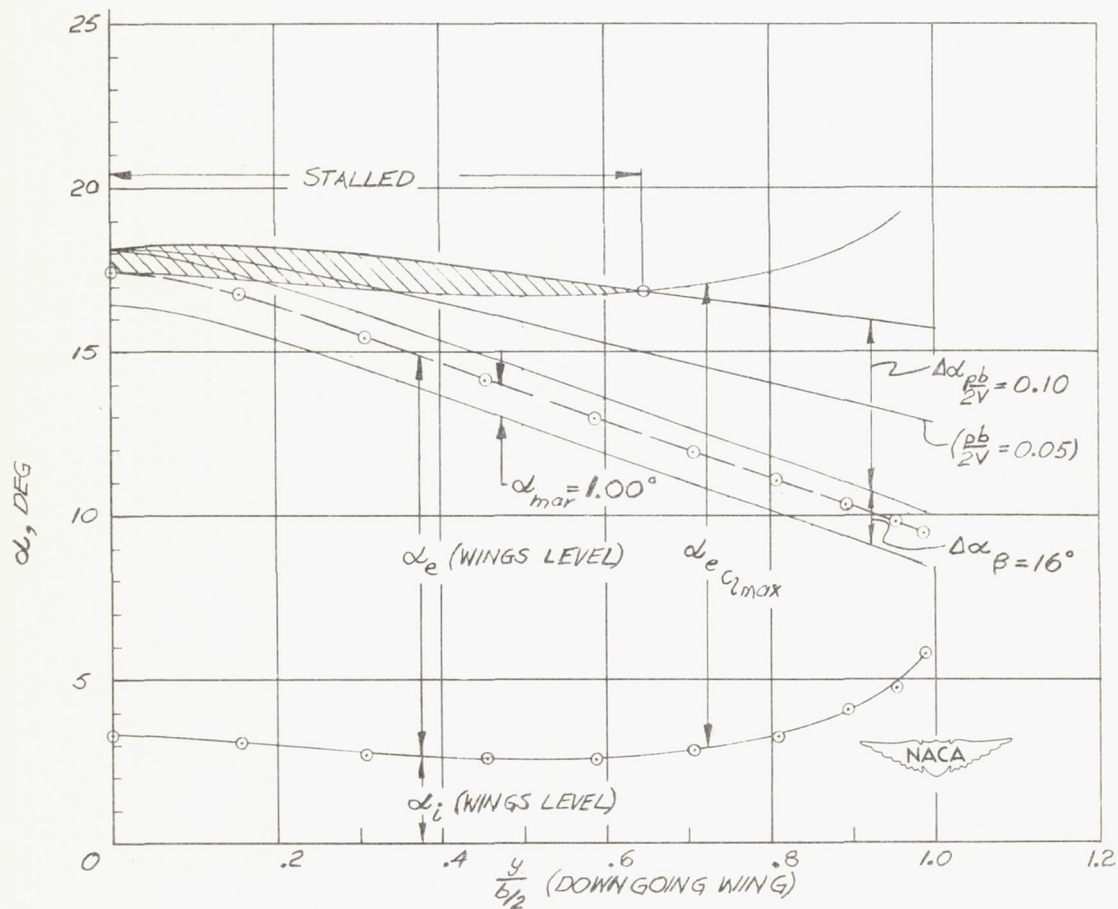

(b) Idealized angle-of-attack redistribution in roll; wind axis fixed.

Figure 20.- Span load and angle-of-attack distribution. 8° of washout.

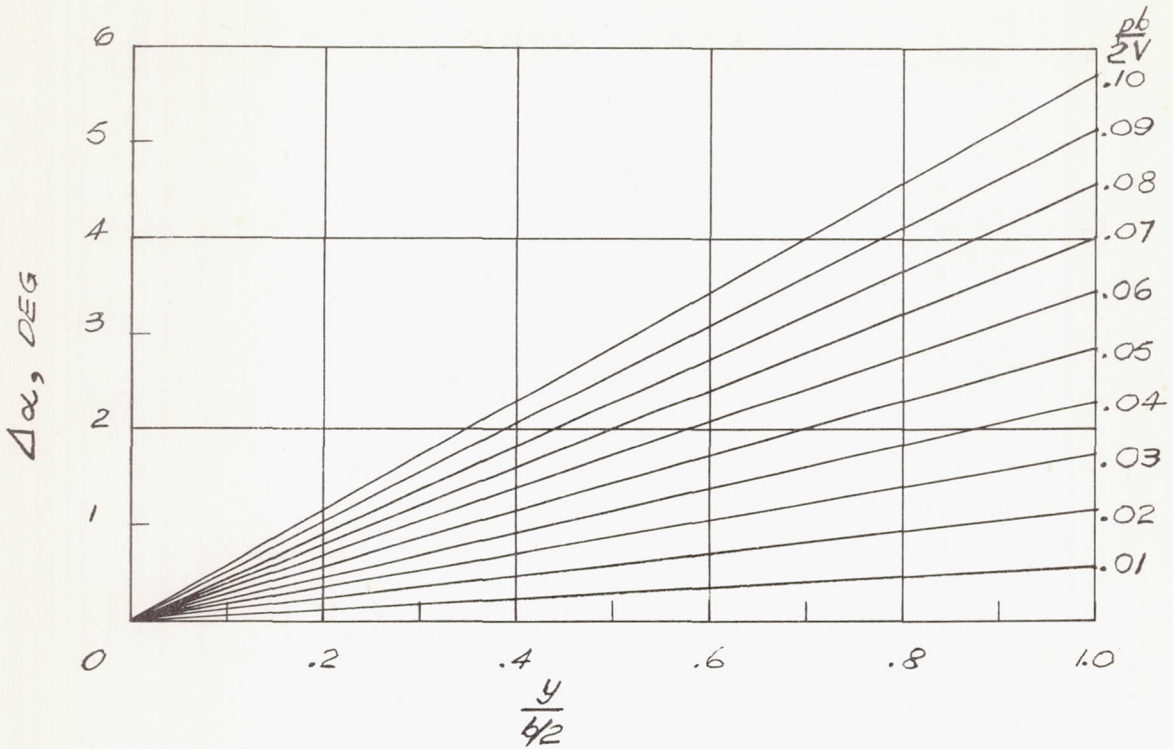

(a) Due to roll (downgoing wing).

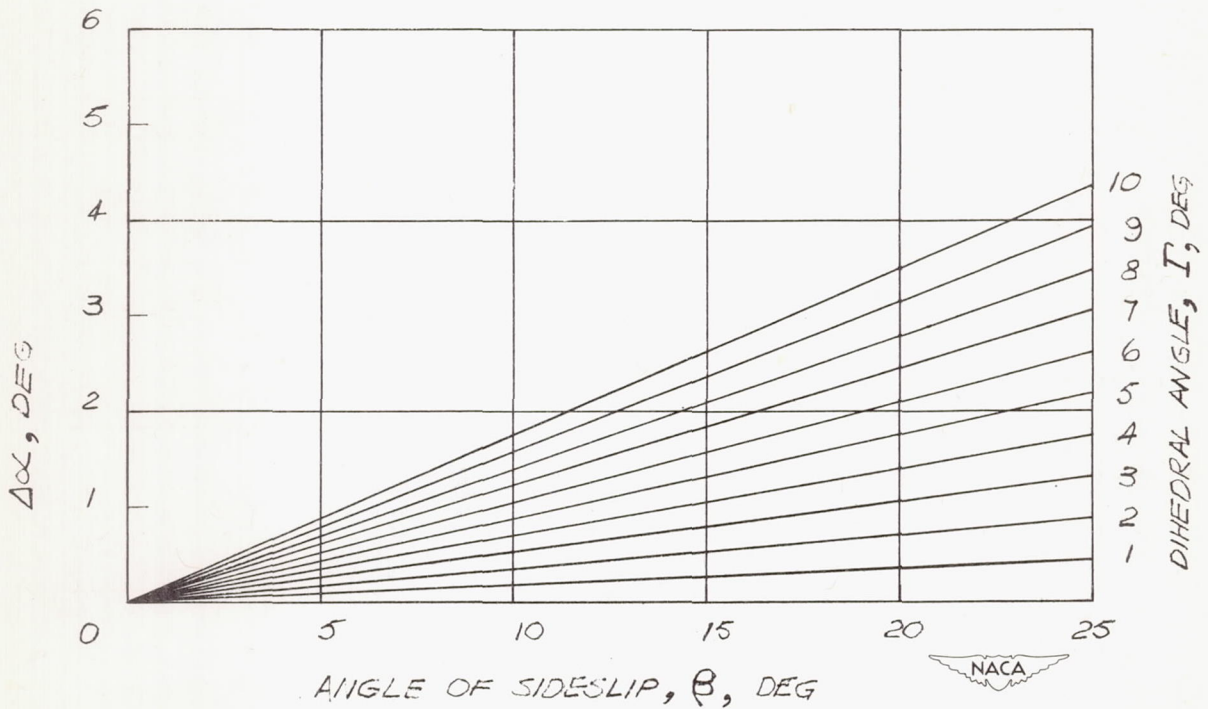

(b) Due to yaw (leading wing).

Figure 21.- Increments of angle of attack during rolling maneuver.

