

NATIONAL ADVISORY COMMITTEE FOR AERONAUTICS

TECHNICAL NOTE 3364

INVESTIGATION OF EFFECTIVENESS OF LARGE-CHORD SLOTTED
FLAPS IN DEFLECTING PROPELLER SLIPSTREAMS DOWNWARD
FOR VERTICAL TAKE-OFF AND LOW-SPEED FLIGHT

By Richard E. Kuhn and John W. Draper

Langley Aeronautical Laboratory
Langley Field, Va.

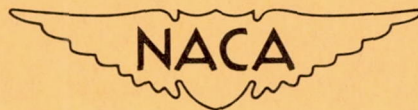

Washington

January 1955

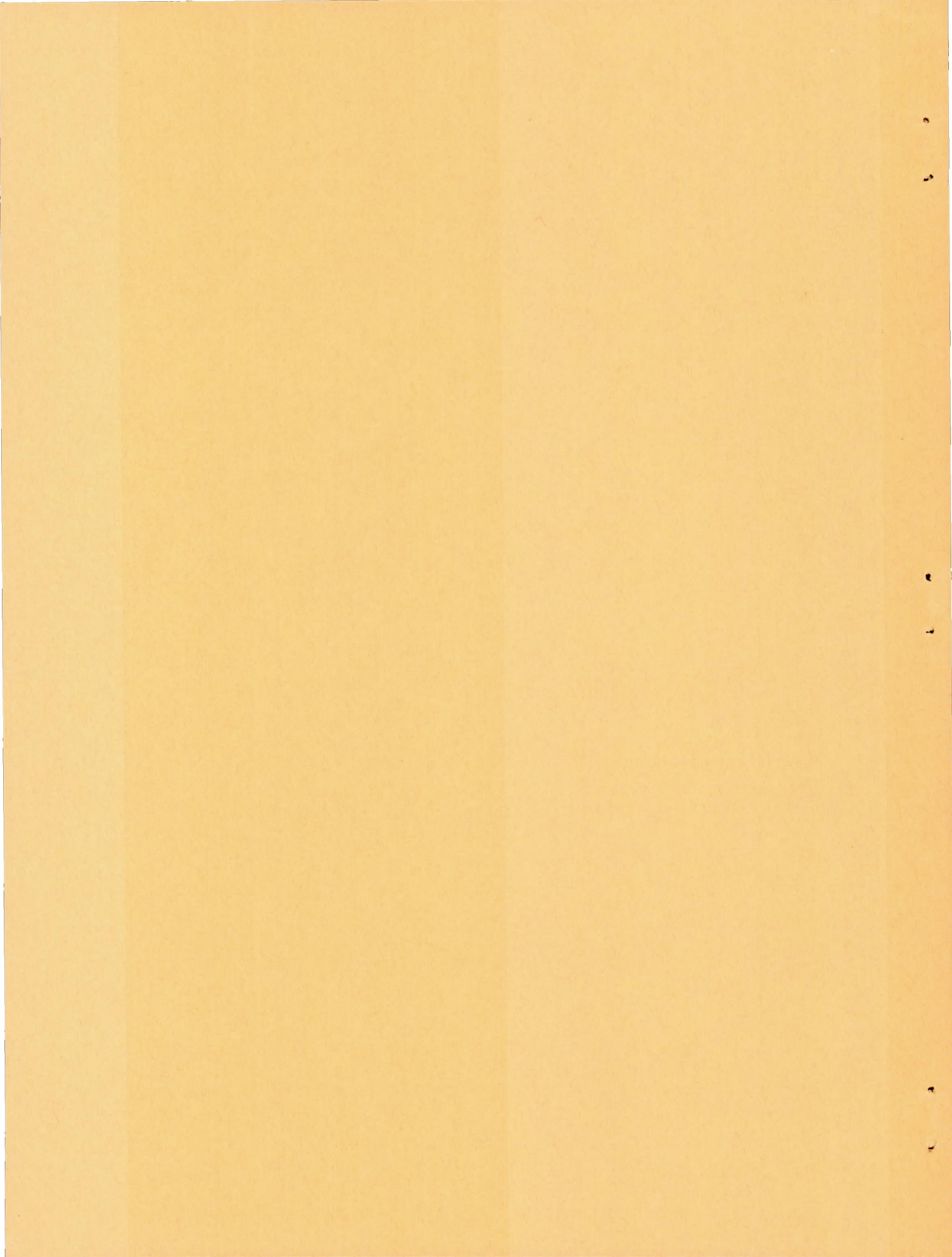

TECHNICAL NOTE 3364

INVESTIGATION OF EFFECTIVENESS OF LARGE-CHORD SLOTTED
FLAPS IN DEFLECTING PROPELLER SLIPSTREAMS DOWNWARD
FOR VERTICAL TAKE-OFF AND LOW-SPEED FLIGHT

By Richard E. Kuhn and John W. Draper

SUMMARY

An investigation of the effectiveness of a wing equipped with large-chord slotted flaps in rotating the thrust vector of propellers through the angles required for vertical take-off and for flight at very low speeds has been conducted in the facilities of the Langley 300 MPH 7- by 10-foot tunnel.

Under conditions of static thrust and with zero incidence between the thrust axis and the wing chord plane, the slotted flaps were effective in rotating the thrust vector upward about 63° with a loss of slightly less than 10 percent of the thrust. When an auxiliary vane was added above the wing, the thrust vector was rotated upward 74° with a loss of only about 10 percent of the thrust. With this vane configuration, vertical take-off could be achieved with an initial attitude of 16° and at airplane weights up to 90 percent of the total propeller thrust. The addition of 10° incidence between the thrust axis and the wing increased the upward rotation of the thrust vector about 10° . For the same turning angle, the diving moments associated with the slotted-flap configurations were approximately twice as large as the diving moments of the configurations with plain flaps and two auxiliary vanes.

INTRODUCTION

The practical utilization of the helicopter has indicated the usefulness of aircraft that are capable of operating from very small bases. The advantages to be gained with an airplane that incorporates both the small-field capabilities of the helicopter and the high-speed potential of conventional airplanes are readily apparent. One possible means of achieving these advantages would be to provide an engine-propeller combination that is capable of providing static thrust in excess of the gross weight. The lift for vertical take-off could then be obtained by deflecting the propeller slipstreams downward by means of wing flaps or both flaps and vanes.

Results of flight tests of a model that utilized a cascade of wings to deflect downward the slipstreams of relatively large-diameter propellers as a means of achieving vertical take-off are reported in reference 1; however, this configuration was designed solely to demonstrate the feasibility of this approach and to study the stability and control problems in hovering and in vertical take-off and landing. No provision was made for forward speed.

A number of wing configurations that may be capable of deflecting the slipstream sufficiently to make vertical take-off possible and that can also be converted to conventional monoplane wings for cruising flight are being investigated at the Langley Aeronautical Laboratory. An illustration of a take-off maneuver that would be possible with this type of aircraft is presented as figure 1.

The data of reference 2 indicate that a configuration having large-chord plain flaps and two auxiliary vanes may possibly perform the necessary aerodynamic functions; however, the process of retracting and storing the two auxiliary vanes for conversion to a monoplane wing may involve serious mechanical problems.

The present investigation of the use of large-chord slotted flaps was undertaken in an attempt to develop a configuration for deflecting the propeller slipstream through the large turning angles required for vertical take-off without resorting to the use of auxiliary vanes or, at least, to provide adequate slipstream deflection with a simpler vane configuration.

SYMBOLS

When a wing is located in the slipstream of a propeller, large forces and moments can be produced even though the free-stream velocity decreases to zero. For this condition, coefficients based on the free-stream dynamic pressure approach infinity and become meaningless. It appears appropriate, therefore, to base the coefficients on the dynamic pressure in the slipstream. The coefficients based on this dynamic pressure are indicated in the present paper by the use of a double prime. The relations between the thrust and the dynamic pressure and velocity in the slipstream have been derived in reference 2.

The positive sense of the forces, moments, and angles determined for the static-thrust tests is shown in figure 2. For the tests with forward speed, the usual convention for forces was used; that is, the lift and longitudinal force were taken perpendicular and parallel, respectively, to the free stream.

C_L'' lift coefficient, $\frac{L}{q'S/2}$

C_m''	pitching-moment coefficient, $\frac{M}{\bar{c}q''S/2}$
C_X''	longitudinal-force coefficient, $\frac{X}{q''S/2}$
T_c''	thrust coefficient, $\frac{T}{q''D^2\pi/4}$
c	wing chord, ft
\bar{c}	mean aerodynamic chord of wing, ft
D	propeller diameter, ft
i_w	wing incidence, deg
L	lift, lb
M	pitching moment, ft-lb
q	free-stream dynamic pressure, $\rho V^2/2$, lb/sq ft
q''	dynamic pressure in slipstream, $q + \frac{T}{\pi D^2/4}$, lb/sq ft
R	radius to propeller tip, ft
S	twice area of semispan wing, sq ft
T	thrust per propeller, lb
V	free-stream velocity, ft/sec
X	longitudinal force, lb
x	distance along chord from leading edge, percent chord
y	distance perpendicular to chord, percent chord
α	angle of attack between thrust axis and relative wind, deg
β	propeller-blade angle at 0.75 radius, deg

δ_f	flap deflection (subscript "30" or "60" indicates percent chord deflected), deg
θ	inclination of resultant-force vector from thrust axis at zero forward speed, $\text{arc tan } \frac{C_L''}{C_X''}$, deg
ρ	mass density of air, slugs/cu ft

MODEL AND APPARATUS

The semispan wing in this investigation had an aspect ratio of 4.55, a taper ratio of 0.714, and an NACA 0015 airfoil section. A plan view and a photograph of the model are presented in figures 3 and 4, respectively. The geometric characteristics of the model are presented in the following table:

Wing:

Area (semispan), sq ft	5.125
Span (semispan), ft	3.416
Mean aerodynamic chord, ft	1.514
Root chord, ft	1.75
Tip chord, ft	1.25
Airfoil section	NACA 0015
Aspect ratio	4.55
Taper ratio	0.714

Propellers:

Diameter, ft	2.0
Disk area, sq ft	3.14
Nacelle diameter, ft	0.33
Airfoil section	Clark Y

The ordinates of the flaps were derived from the slotted flap 2-h of reference 3 and are presented in table I. The slotted flaps were supported by external brackets as shown in figure 4. The cross section of the auxiliary-vane configuration is shown in figure 5. The vane was made of 1/8-inch sheet steel.

The characteristics of the propellers used are presented in reference 4. The propellers were driven by variable-frequency electric motors rated at 20 horsepower at 18,000 rpm. The large propeller diameter prevented the use of this high rotational speed, and during these tests the propeller speed seldom exceeded 7,500 rpm. The rotational speed was

determined by observing a stroboscopic type of instrument that indicated the output frequency of a small alternator connected to the motor shaft. Both motors were driven from a common power supply, and their speeds were usually matched within 10 rpm.

The motors were mounted inside the aluminum-alloy nacelles through strain-gage beams so that the thrust of each propeller could be measured. In addition, total lift, longitudinal force, and pitching moment of the model were measured on a balance at the root of the wing.

Variations in wing incidence relative to the thrust axis were provided by using different motor-mount brackets for each incidence setting. These brackets were designed so that the thrust axis of each propeller intersected the chord plane at the quarter chord of the mean aerodynamic chord.

TESTS AND CORRECTIONS

The investigation used two different experimental setups. Most of the tests were conducted at zero forward speed on the static-thrust stand at one end of a large room as shown in figures 4 and 6. For these tests, the thrust on each propeller was held at 25 pounds, which gave a dynamic pressure of 8 pounds per square foot in the slipstream. The blade angles of the two propellers were adjusted slightly ($\pm 0.1^\circ$ or less) in order to develop the same thrust on both propellers. The effects of flap deflection, propeller blade angle ($\beta_{.75R} = 3.7^\circ$ and 8°), wing incidence, and the addition of an auxiliary vane were investigated at zero forward speed.

A few tests with forward speed were conducted in the Langley 300 MPH 7- by 10-foot tunnel. For these tests, the semispan model was mounted from the tunnel ceiling and was equipped with only the inboard propeller. The shaft thrust of the propeller was held constant throughout the angle-of-attack range and was chosen to give a dynamic pressure of 8 pounds per square foot in the slipstream at zero angle of attack. Tests were conducted with the propeller removed and with the propeller installed and operating at several thrust coefficients. The Reynolds number in the slipstream based on the mean aerodynamic chord of 1.514 feet was 0.8×10^6 .

Inasmuch as all static-thrust tests were conducted in a large room, none of the corrections that are normally applicable to wind-tunnel tests were applied for these tests.

The data obtained in the Langley 300 MPH 7- by 10-foot tunnel have been corrected for the effects of the tunnel walls on the angle of attack and longitudinal-force coefficient of the model and on the velocity in the tunnel. These corrections were applied as indicated in reference 4.

Corrections to the free-stream dynamic pressure for the effects of model blockage are negligible at low angles of attack and have not been applied but can be determined from reference 4.

RESULTS AND DISCUSSION

Static-Thrust Condition

In order to achieve vertical take-off, it is necessary to satisfy the conditions in which the lift is greater than the weight and the net longitudinal force is equal to zero. The configuration of reference 2 with plain flaps and auxiliary vanes would satisfy these conditions with an initial attitude of 23° for airplane weights up to 95 percent of the propeller thrust. Without the auxiliary vanes an attitude of about 45° would be required for the plain-flap configuration.

Basic slotted-flap configuration.- The slotted-flap configuration shown in figure 2 was investigated to determine whether the desired turning could be obtained with a less complicated wing arrangement than that of reference 2 (plain flap with two auxiliary vanes). The effect of flap deflection on the aerodynamic characteristics is shown in figure 7. A comparison of the data of figures 7(c), (d), and (e) with the data of reference 2 indicates an appreciable improvement in turning effectiveness with the slotted-flap configuration as compared with the plain-flap configuration. Deflection of the 60-percent-chord flap 60° and the 30-percent-chord flap 40° effectively rotated the thrust vector upward about 63° with a loss of slightly less than 10 percent of the thrust.

The slot openings of the flap for this investigation were determined by the path of the nose of each flap (table I) which was derived from reference 3. These openings are not necessarily optimum for this configuration. It is well known that, under forward-speed conditions without slipstream, variations in slot openings may have rather large effects on the aerodynamic characteristics of wings equipped with slotted flaps. One test in which the flap was incorrectly assembled indicated that these same effects may probably occur also at zero forward speed when the slotted flaps are used to deflect the propeller slipstream.

Effect of auxiliary vane.- The auxiliary-vane configuration shown in figure 5 was tested in an attempt to increase the rotation of the effective thrust vector. This vane could possibly be designed as a "slat" on the top surface of the leading edge of the 60-percent-chord flap. It could be extended to the desired position after the 60-percent-chord flap had been deflected about 60° . The contour of the 1/8-inch-sheet metal vane tested was not exactly the same as the upper surface of the flap and thus the vane could not be retracted (see fig. 5); however, the contour

differences were small and were not expected to produce important effects on the results obtained.

The aerodynamic characteristics of the configuration with the auxiliary vane extended are presented in figure 8. With the auxiliary vane extended the effective thrust vector was rotated upward 74° with a loss of only about 10 percent of the thrust (fig. 8(e)). Vertical take-off would be possible with this configuration at an initial attitude of 16° and at airplane weights up to 90 percent of the total propeller thrust.

Effect of incidence.- Positive incidence between the wing chord plane and the propeller thrust axis is seen to increase appreciably the turning angle (figs. 9 and 10). At the lower turning angles an increase of about 3.5° is obtained for each 5° of incidence; however, at the higher turning angles the ratio of increased turning angle to wing incidence angle is almost one to one within the 10° range of incidence investigated.

The inclusion of incidence between the wing and the thrust axis had no consistent effect on the nose-down pitching moment for constant flap settings (fig. 9(b)). The flap deflections required for a given turning angle were reduced, however, and resulted in a small reduction in pitching moment for a given turning angle.

The effect of wing incidence was obtained with a propeller blade angle of 3.7° . The data of reference 5 indicated a small improvement in the turning angle for the wing with plain flaps when the propeller blade angle was reduced from 8° to 3.7° , and it was expected that a similar improvement might be effected with the slotted-flap configuration. The data of figure 11 indicate that, in general, for the slotted-flap configuration the effects of changing the propeller blade angle were small and would probably not greatly alter the variation of turning effectiveness with incidence.

Two sets of data were obtained for the configuration with the 60-percent-chord flap deflected 60° and a blade angle of 8° (figs. 7 and 11). After the data of figures 7 and 8 were obtained, it was decided to extend the tests to include the effects of wing incidence and propeller blade angle. During the intervening period, the wing was disassembled and had to be completely rebuilt for the later tests. Consequently, it was considered advisable to conduct repeat tests on one configuration with a blade angle of 8° in order to provide a better basis of comparison for the effects of propeller blade angle. Comparison of the repeat data $\delta_{f60} = 60^\circ$ (fig. 11) with the first data (fig. 7) indicates some appreciable differences. It is possible that, after the model was reassembled, the slot openings were slightly different from those for the earlier tests; as mentioned previously, variations in slot opening have rather large effects.

Tests With Forward Speed

A few tests with forward speed were conducted in the Langley 300 MPH 7- by 10-foot tunnel. The effect of deflection of the 30-percent-chord flap on the aerodynamic characteristics of the wing alone are presented in figure 12. A maximum lift coefficient of 2.6 was obtained with a deflection of 60° . The lift and pitching-moment data for a deflection of 40° are seen to be almost the same as for a deflection of 60° (figs. 12(a) and (c)). Increasing the flap deflection from 40° to 60° results mainly in an increase in the longitudinal-force coefficient (fig. 12(b)).

It is interesting to note that the same general trend of the effects of flap deflections is shown in the static-thrust data of figure 7. The rate of change of lift coefficient and pitching-moment coefficient is considerably reduced in changing the flap deflection from 40° to 60° ; however, the longitudinal-force coefficient continues to increase. This increase in longitudinal-force coefficient helps to increase the turning angle.

The effects of slipstream on the aerodynamic characteristics with the 30-percent-chord flap deflected 60° are presented in figure 13. The thrust and the free-stream dynamic pressure were held constant throughout the angle-of-attack range. The coefficients presented (fig. 13) are based on the dynamic pressure in the slipstream. Increasing the thrust coefficient is seen to increase the angle of attack for maximum lift and to decrease the variation of lift coefficient with angle of attack at angles of attack above that for maximum lift.

Comparison of Results For Plain-Flap

and Slotted-Flap Configurations

The turning effectiveness and the pitching-moment coefficients of the plain-flap configuration (ref. 2) and the slotted-flap configuration of the present investigation at zero forward speed are compared in figures 14 and 15. It can be seen that, without auxiliary vanes or wing incidence, the combined deflections of the 30- and 60-percent-chord slotted flaps were effective in rotating the thrust vector upward through larger turning angles than those obtained with the combined deflection of the plain flaps (fig. 14). The diving moments associated with the slotted flap, however, were much greater than those for the plain flap (fig. 15).

The slotted-flap configuration with one auxiliary vane gives slightly higher turning angles than the plain-flap configurations with two vanes. The diving moments for the slotted-flap configuration, however, are approximately twice as large as those for the plain-flap configuration, for the same turning angle.

Positive incidence of about 10° between the wing chord plane and the thrust axis increases the upward rotation of the thrust vector about 10° and results in a slight decrease in pitching moment for the same turning angle.

CONCLUSIONS

An investigation of the effectiveness of a wing with large-chord slotted flaps in rotating the effective propeller-thrust vector upward to provide lift for vertical take-off and low-speed flight indicates the following conclusions:

1. Under conditions of static thrust and with zero incidence between the wing chord plane and the thrust axis, the wing configuration employing only large-chord double-slotted flaps was effective in rotating the thrust vector upward about 63° with a loss of slightly less than 10 percent of the thrust.

2. The slotted-flap configuration with one auxiliary vane rotated the effective thrust vector upward 74° with a loss of only about 10 percent of the thrust. With this configuration, vertical take-off could be made with an initial attitude of 16° and at airplane weights up to 90 percent of the total propeller thrust.

3. The addition of 10° wing incidence between the wing chord plane of the slotted-flap configuration and the thrust axis, with the auxiliary vane removed, increased the upward rotation of the thrust vector about 10° .

4. For the same turning angle, the diving moments associated with the slotted-flap configurations were approximately twice as large as the diving moments for the configurations with plain flaps and two auxiliary vanes.

Langley Aeronautical Laboratory,
National Advisory Committee for Aeronautics,
Langley Field, Va., October 22, 1954.

REFERENCES

1. McKinney, Marion O., Tosti, Louis P., and Davenport, Edwin E.: Dynamic Stability and Control Characteristics of a Cascade-Wing Vertically Rising Airplane Model in Take-Offs, Landings, and Hovering Flight. NACA TN 3198, 1954.
2. Kuhn, Richard E., and Draper, John W.: An Investigation of a Wing-Propeller Configuration Employing Large-Chord Plain Flaps and Large-Diameter Propellers for Low-Speed Flight and Vertical Take-Off. TN 3307, 1954.
3. Wenzinger, Carl J., and Harris, Thomas A.: Wind-Tunnel Investigation of an N.A.C.A. 23012 Airfoil With Various Arrangements of Slotted Flaps. NACA Rep. 664, 1939.
4. Draper, John W., and Kuhn, Richard E.: Investigation of the Aerodynamic Characteristics of a Model Wing-Propeller Combination and of the Wing and Propeller Separately at Angles of Attack up to 90° . NACA TN 3304, 1954.
5. Draper, John W., and Kuhn, Richard E.: Some Effects of Propeller Operation and Location on Ability of a Wing With Plain Flaps To Deflect Propeller Slipstreams Downward for Vertical Take-Off. NACA TN 3360, 1954.

TABLE I.- DETAILS OF THE WING AND FLAP SECTIONS

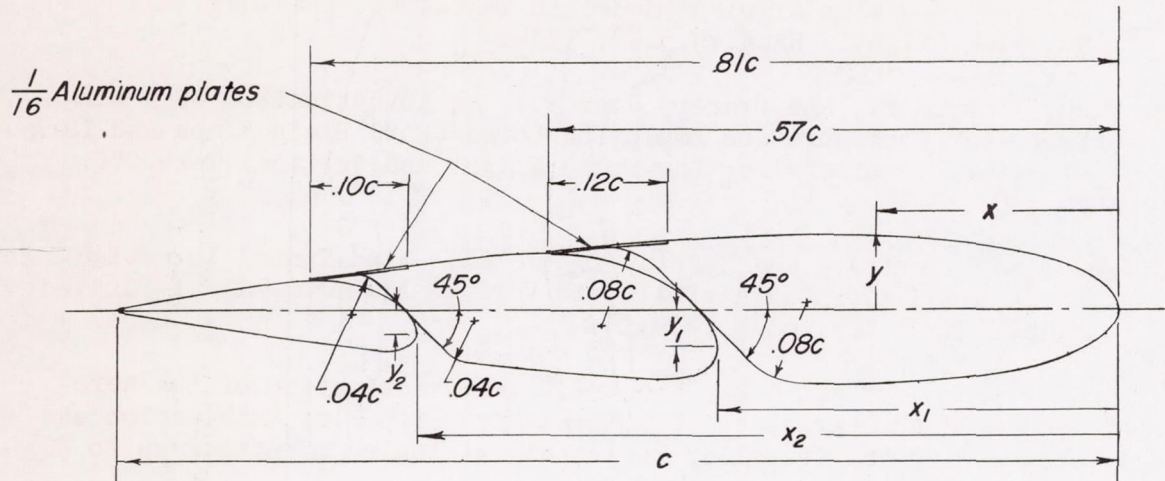

WING AND FLAP ORDINATES

Station x, percent chord	Ordinate, y, percent chord					
	Wing, NACA 0015		0.60c flap		0.30c flap	
	Upper	Lower	Upper	Lower	Upper	Lower
0	0	0	----	----	----	----
1.25	2.37	-2.37	----	----	----	----
2.50	3.27	-3.27	----	----	----	----
5.00	4.40	-4.40	----	----	----	----
7.50	5.25	-5.25	----	----	----	----
10.00	5.85	-5.85	----	----	----	----
15.00	6.68	-6.68	----	----	----	----
20.00	7.17	-7.17	----	----	----	----
25.00	7.43	-7.43	----	----	----	----
30.00	7.50	-7.50	----	----	----	----
40.00	7.25	-7.25	-3.80	-3.80	----	----
40.50	----	----	-2.00	-5.10	----	----
41.00	----	----	-1.10	-5.70	----	----
42.00	----	----	.20	-6.30	----	----
44.00	----	----	1.80	-6.80	----	----
46.00	----	----	3.00	-6.90	----	----
48.00	----	----	3.90	-6.80	----	----
50.00	6.62	-6.62	4.60	-6.62	----	----
54.00	----	----	5.60	----	----	----
58.00	----	----	5.70	----	----	----
60.00	5.70	-5.70	5.70	----	----	----
70.00	4.58	-4.58	----	----	-2.30	-2.30
70.50	----	----	----	----	-1.00	-3.40
71.00	----	----	----	----	.40	-3.70
72.00	----	----	----	----	.60	-4.00
74.00	----	----	----	----	1.70	-4.00
76.00	----	----	----	----	2.50	----
78.00	----	----	----	----	2.90	----
80.00	3.28	-3.28	----	----	3.00	----
82.00	----	----	----	----	2.90	----
90.00	1.81	-1.81	----	----	----	----
95.00	1.01	-1.01	----	----	----	----
100.00	.16	-.16	----	----	----	----

PATH OF THE FLAP NOSE

[Value in percent chord]

δ_f , deg	0.60c flap		0.30c flap	
	x_1	y_1	x_2	y_2
0	40.0	-3.5	70.0	-2.5
10	44.0	-2.0	72.5	-1.5
20	48.0	-1.5	74.7	-1.2
30	52.5	-1.5	77.2	-1.2
40	54.8	.5	79.2	-.2
50	56.0	2.0	80.4	.7
60	57.7	2.5	81.0	1.0
70	59.0	2.8	81.3	2.0

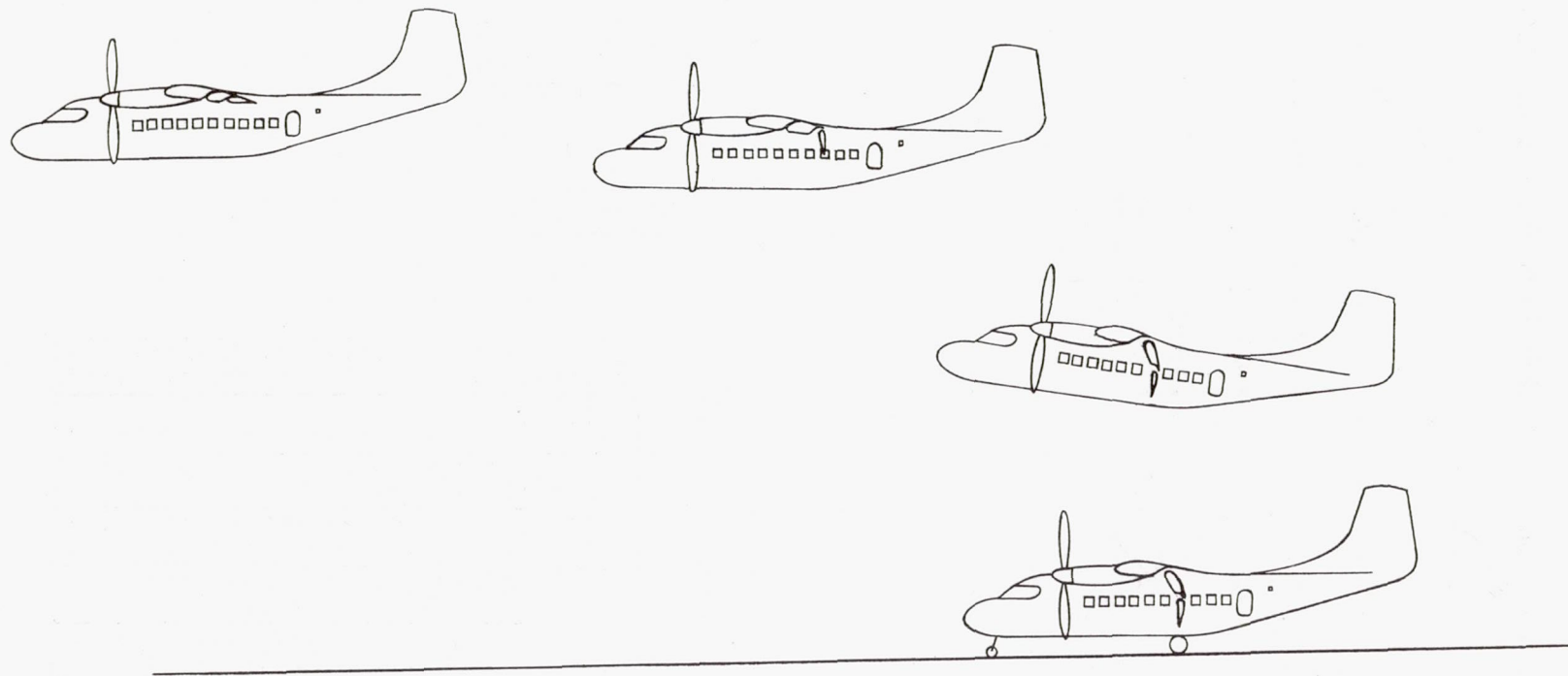

Figure 1.- Illustration of typical take-off and transition to horizontal flight of possible transport configuration for vertical take-off.

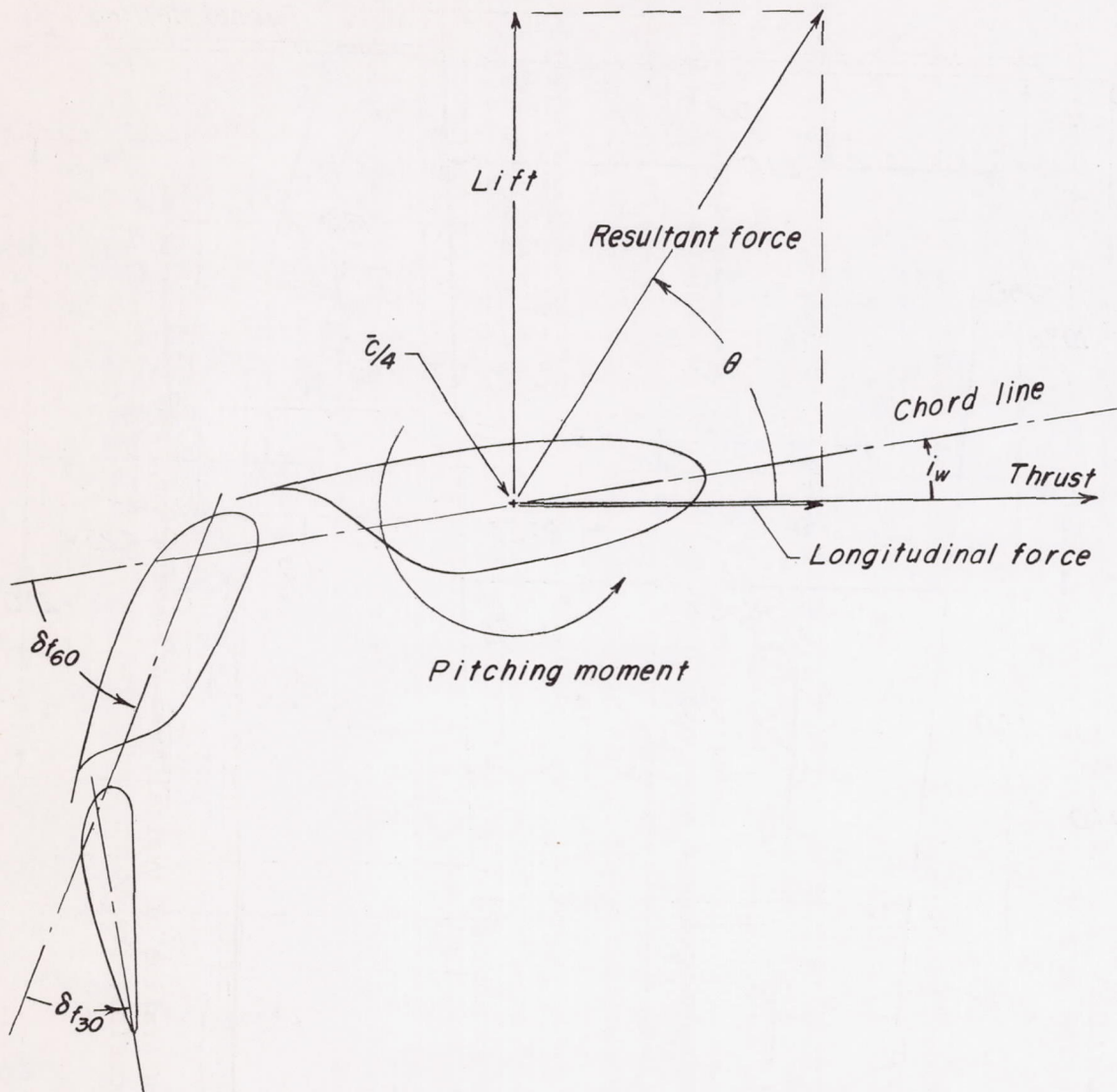

Figure 2.- Conventions used to define positive sense of forces, moments, and angles for static-thrust tests.

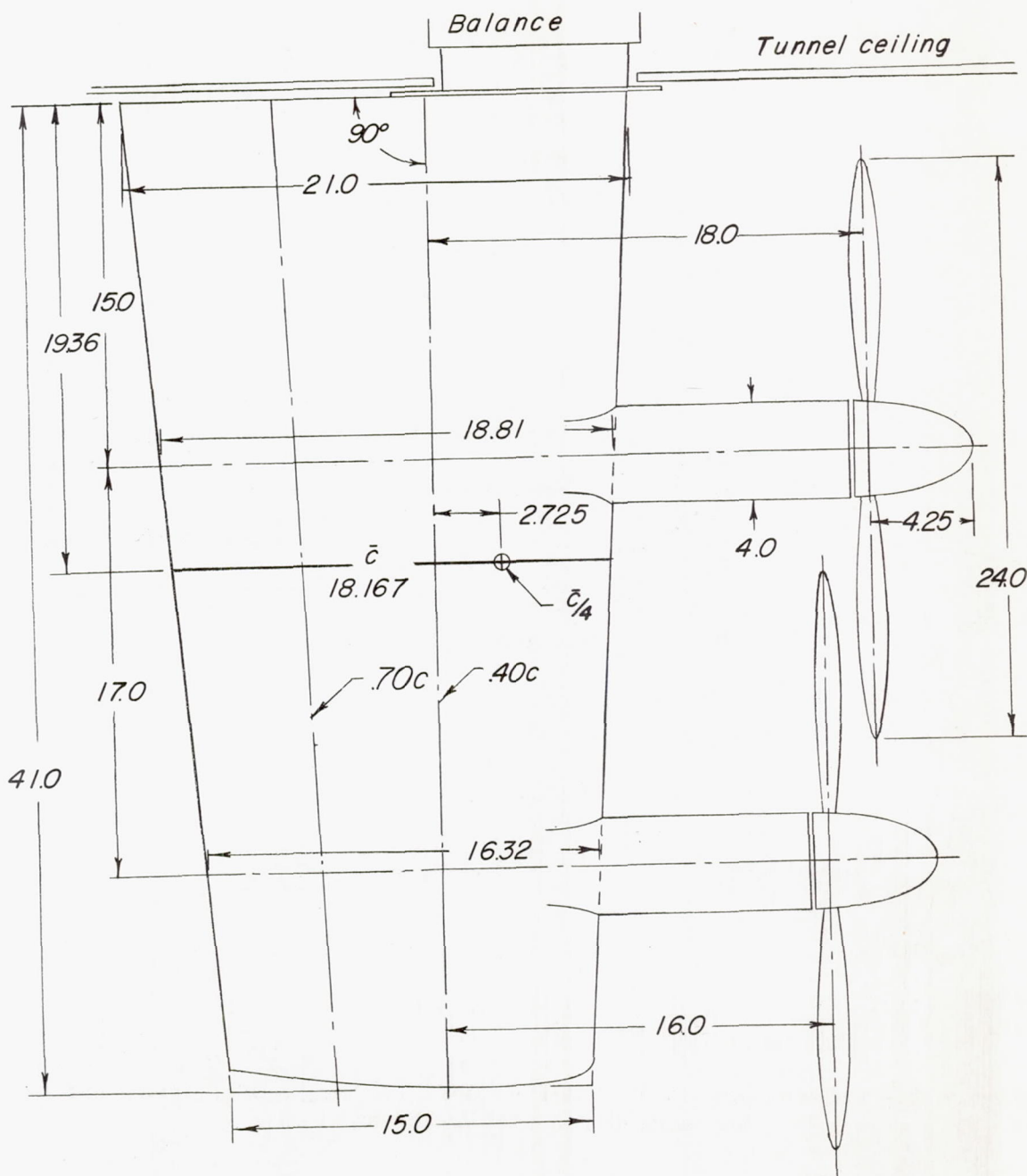

Figure 3.- Plan view of model. All dimensions in inches.

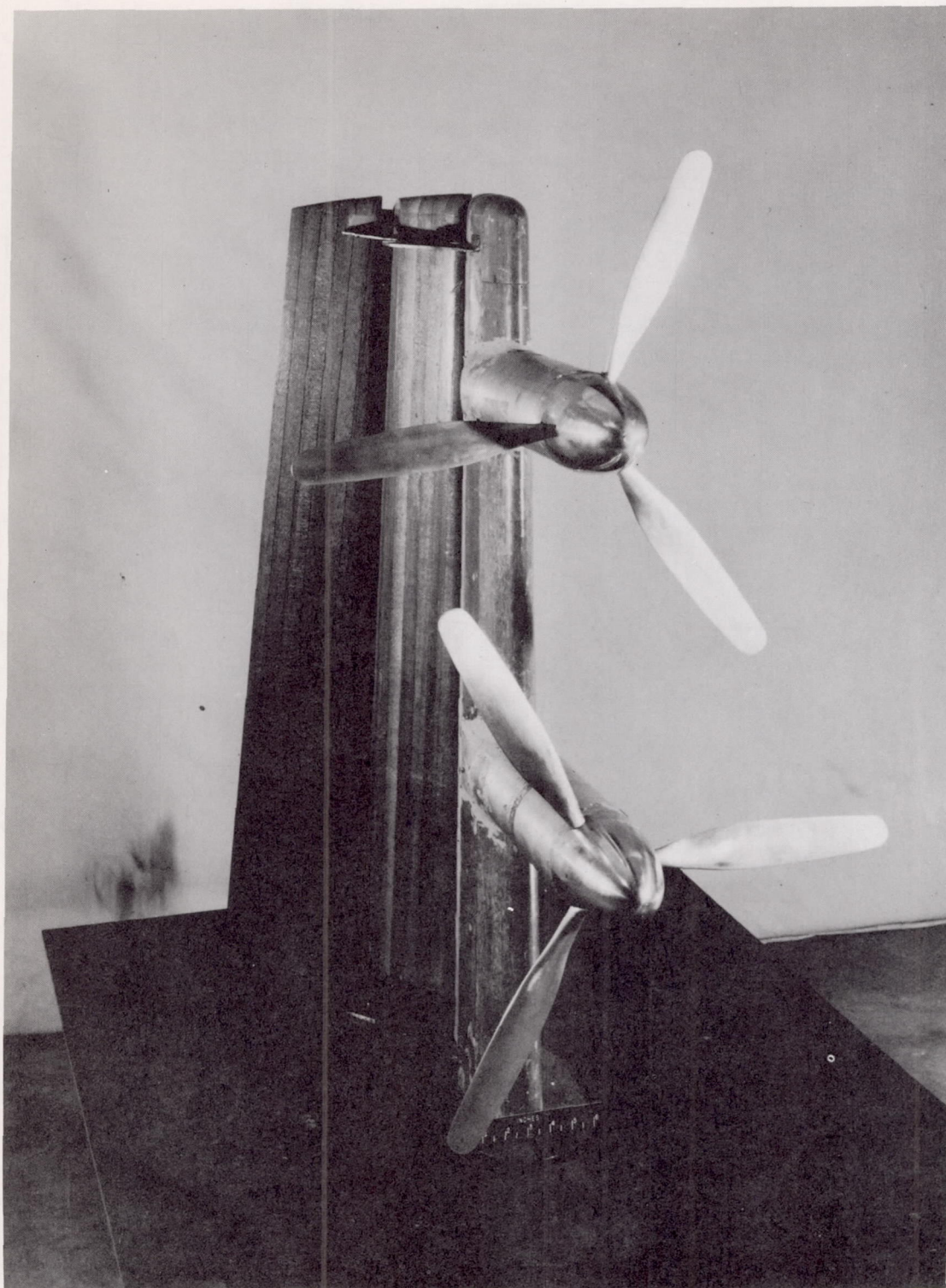

Figure 4.- Model installed on static-thrust stand. $\delta_{f_{60}} = 30^\circ$; $\delta_{f_{30}} = 30^\circ$.

L-85690

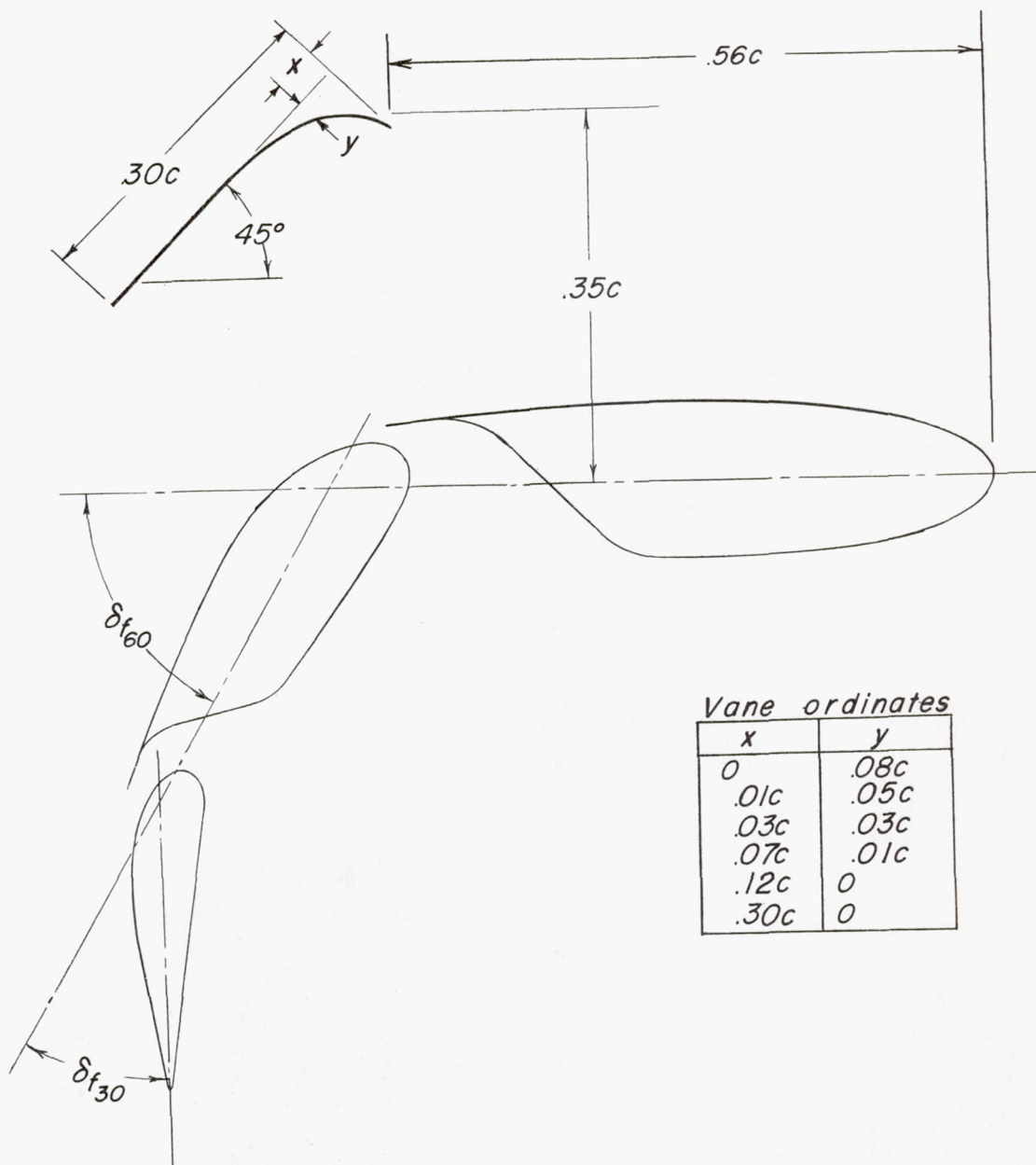

Figure 5.- Cross section of auxiliary-vane configuration.

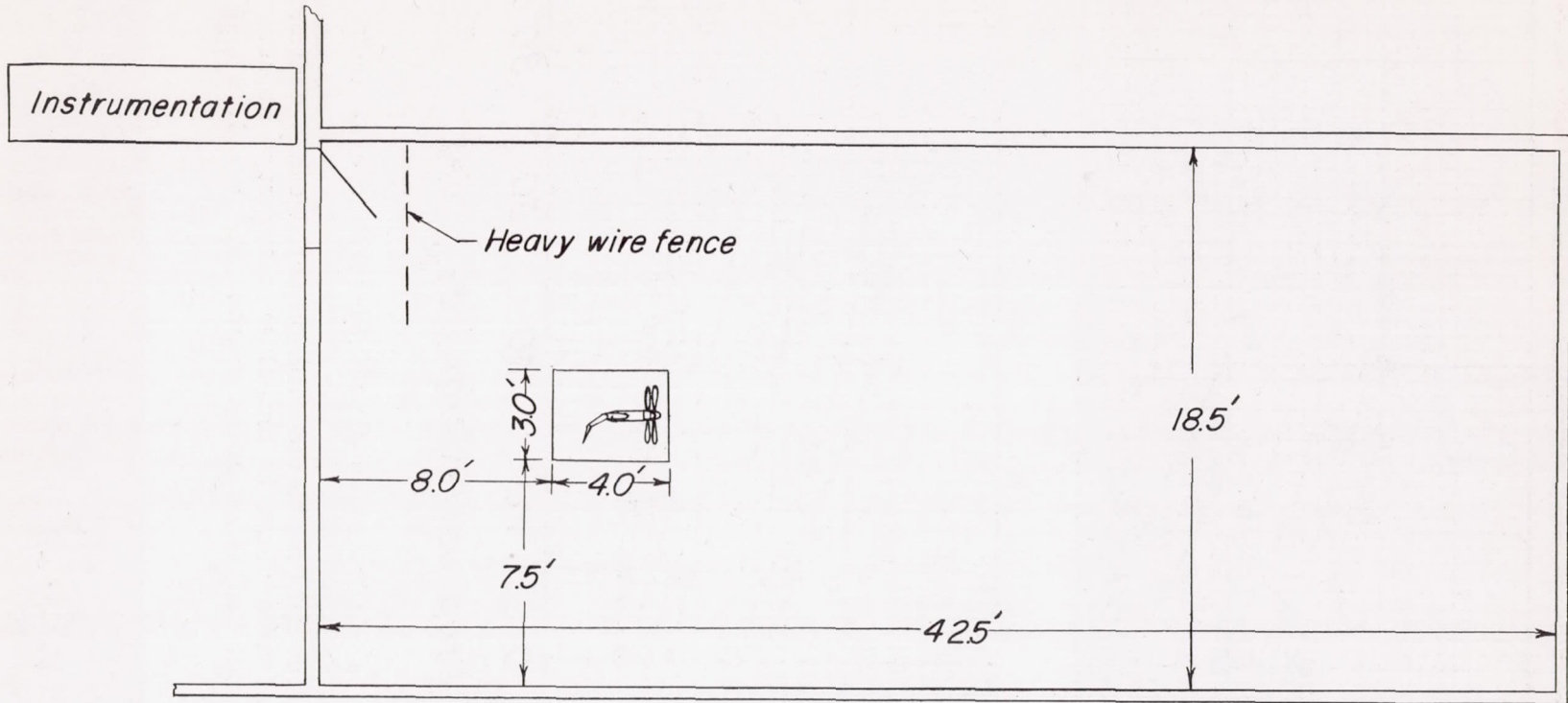
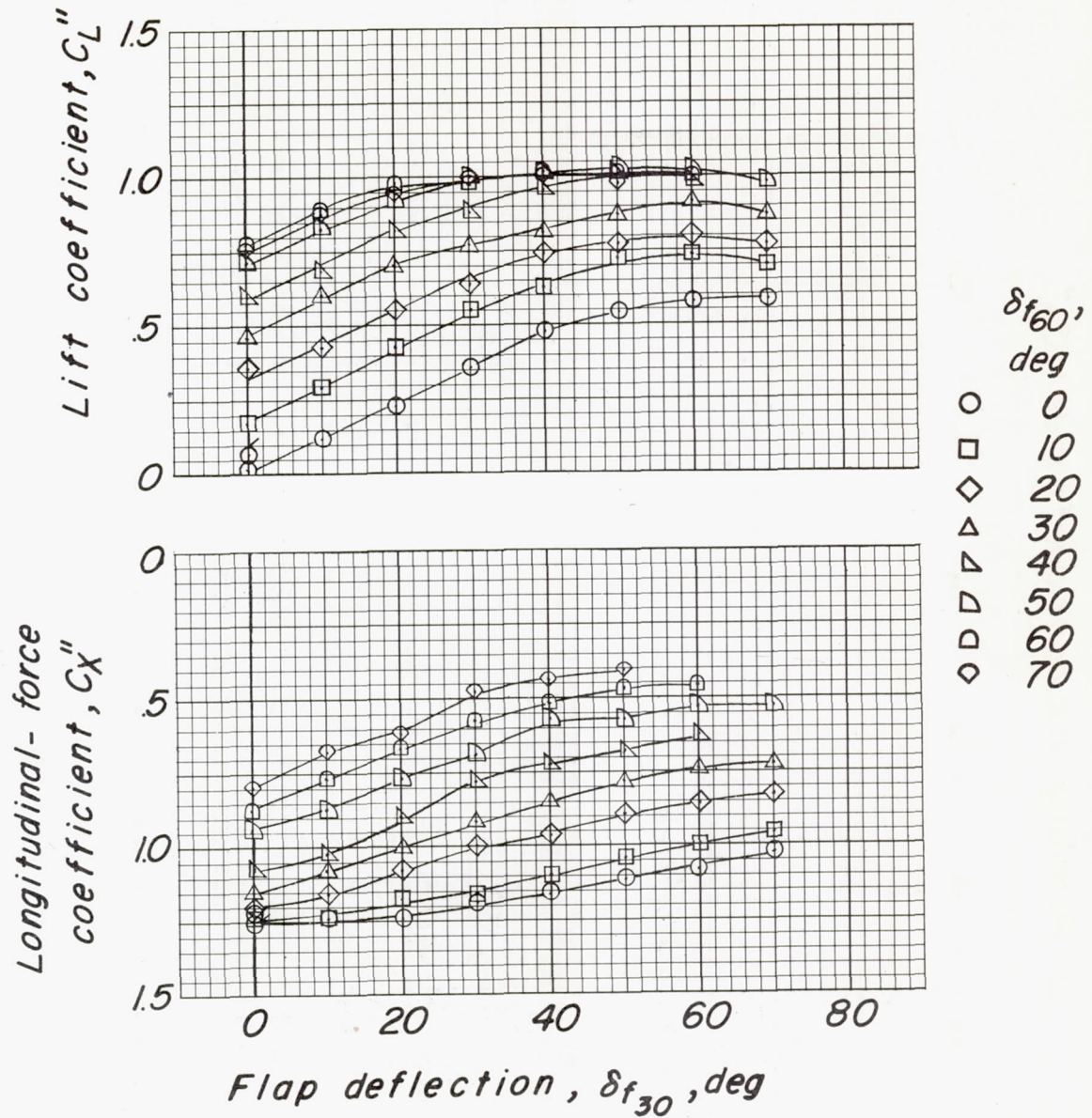
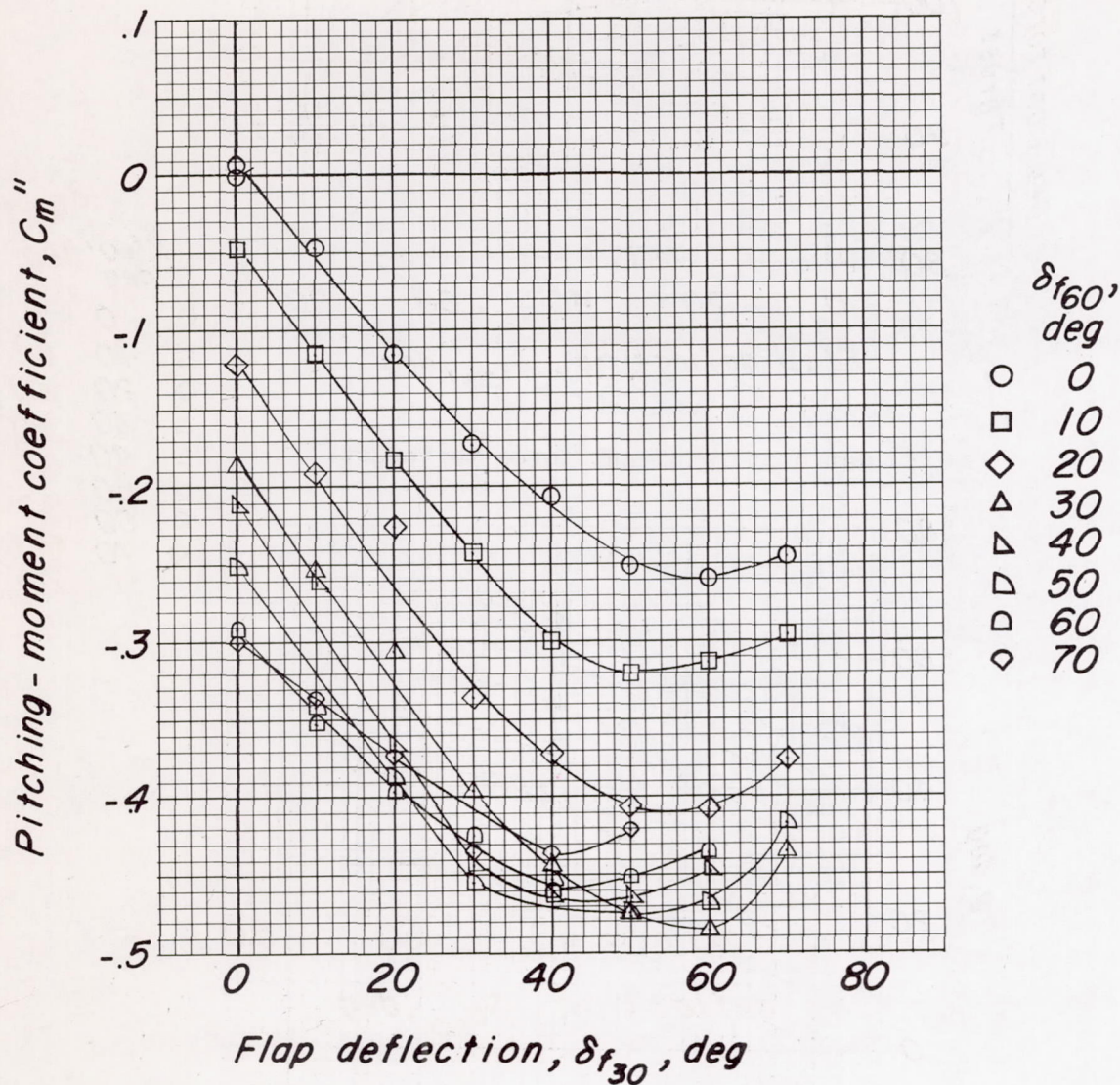

Figure 6.- Plan view of room used for test at zero forward speed.



(a) Lift and longitudinal-force coefficient.

Figure 7.- Effect of flap deflection on aerodynamic characteristics of wing with slotted flaps in propeller slipstream at zero forward speed. Flagged symbol indicates check point. $T_c'' = 1.0$; $\beta_{.75R} = 8^\circ$.



(b) Pitching-moment coefficient.

Figure 7.- Continued.

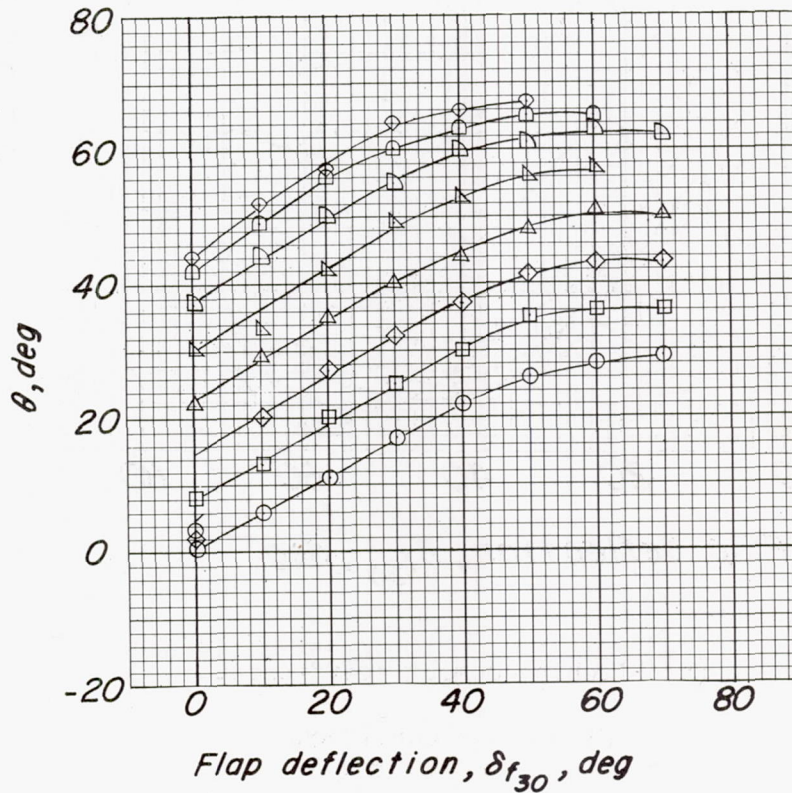
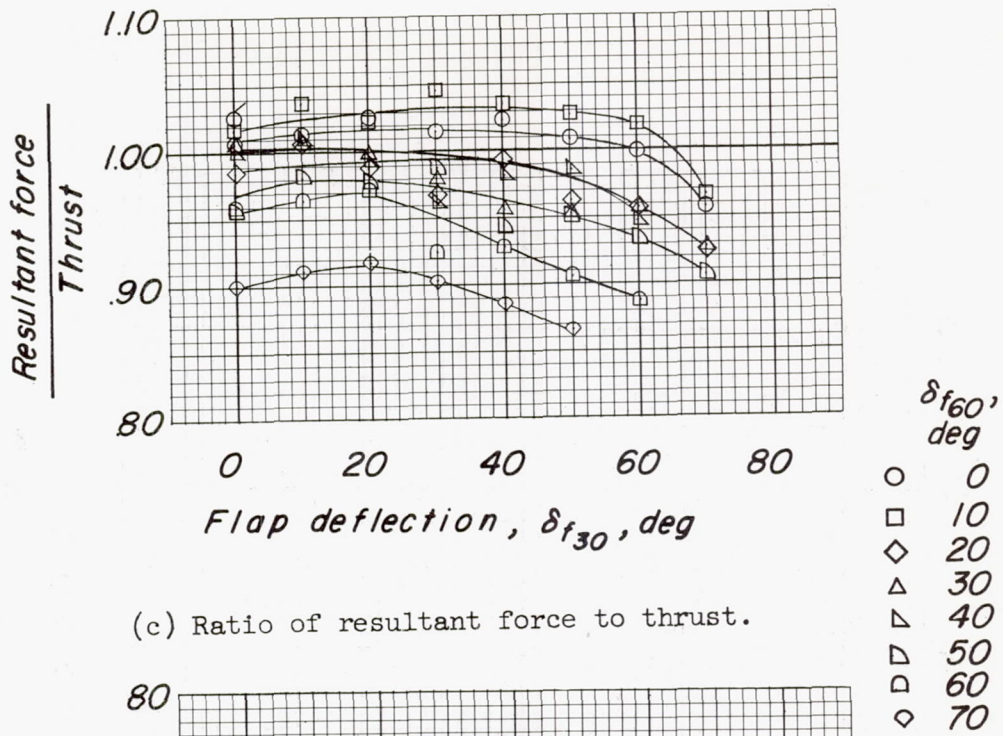
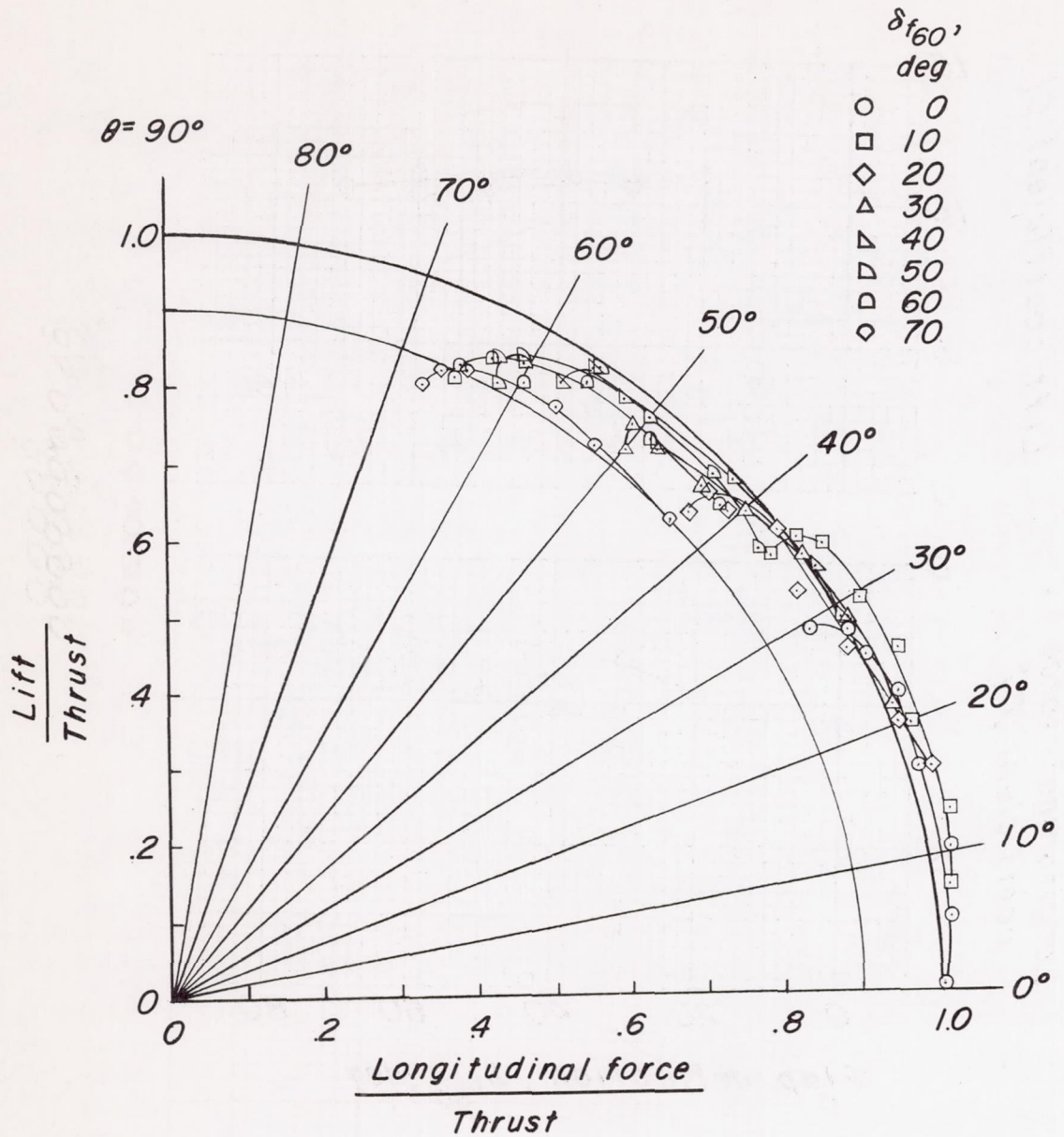
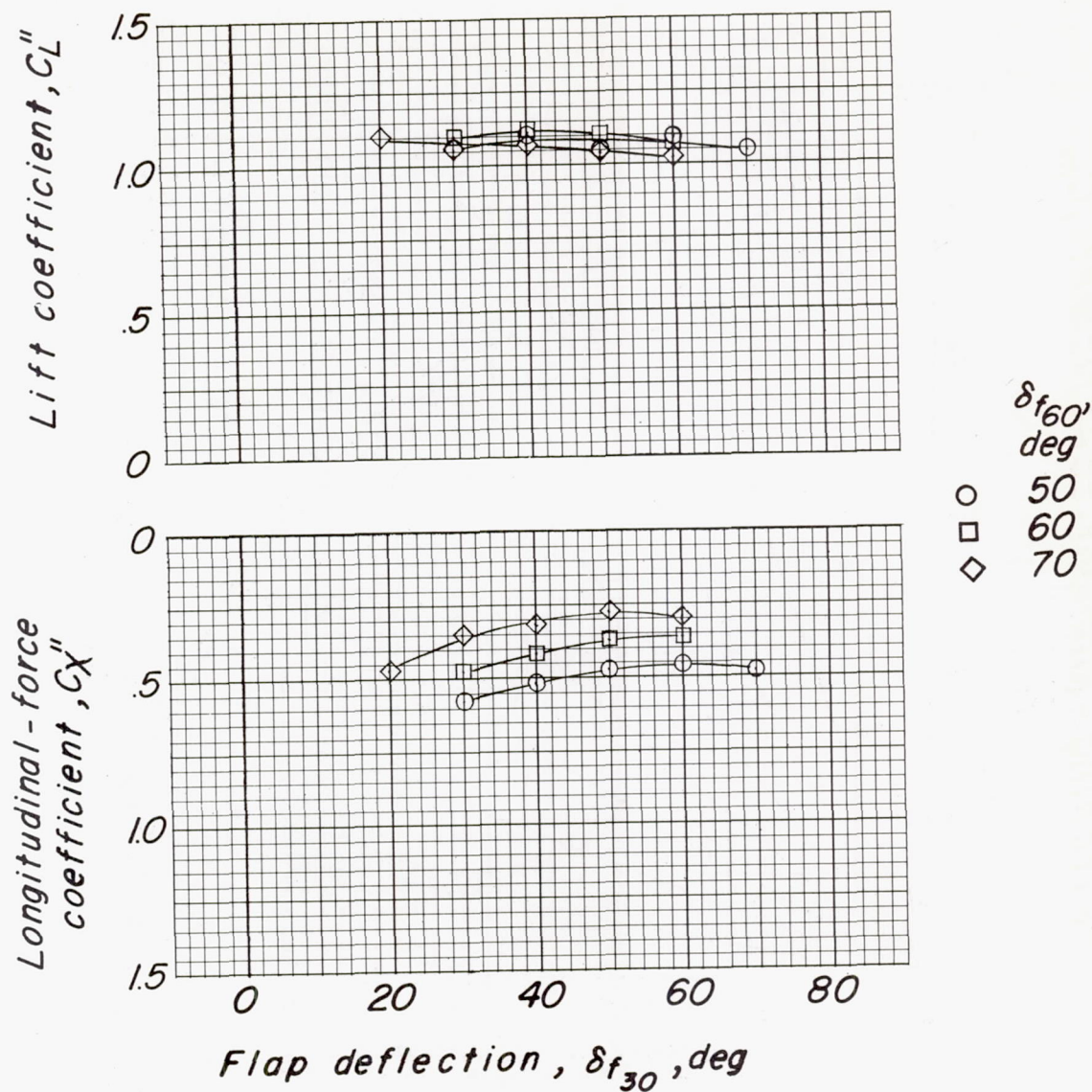

Figure 7.- Continued.



(e) Summary of turning effectiveness.

Figure 7.- Concluded.



(a) Lift and longitudinal-force coefficient.

Figure 8.- Aerodynamic characteristics of model with auxiliary vane.
 $T_c'' = 1.0$; $\beta_{.75R} = 8^\circ$.

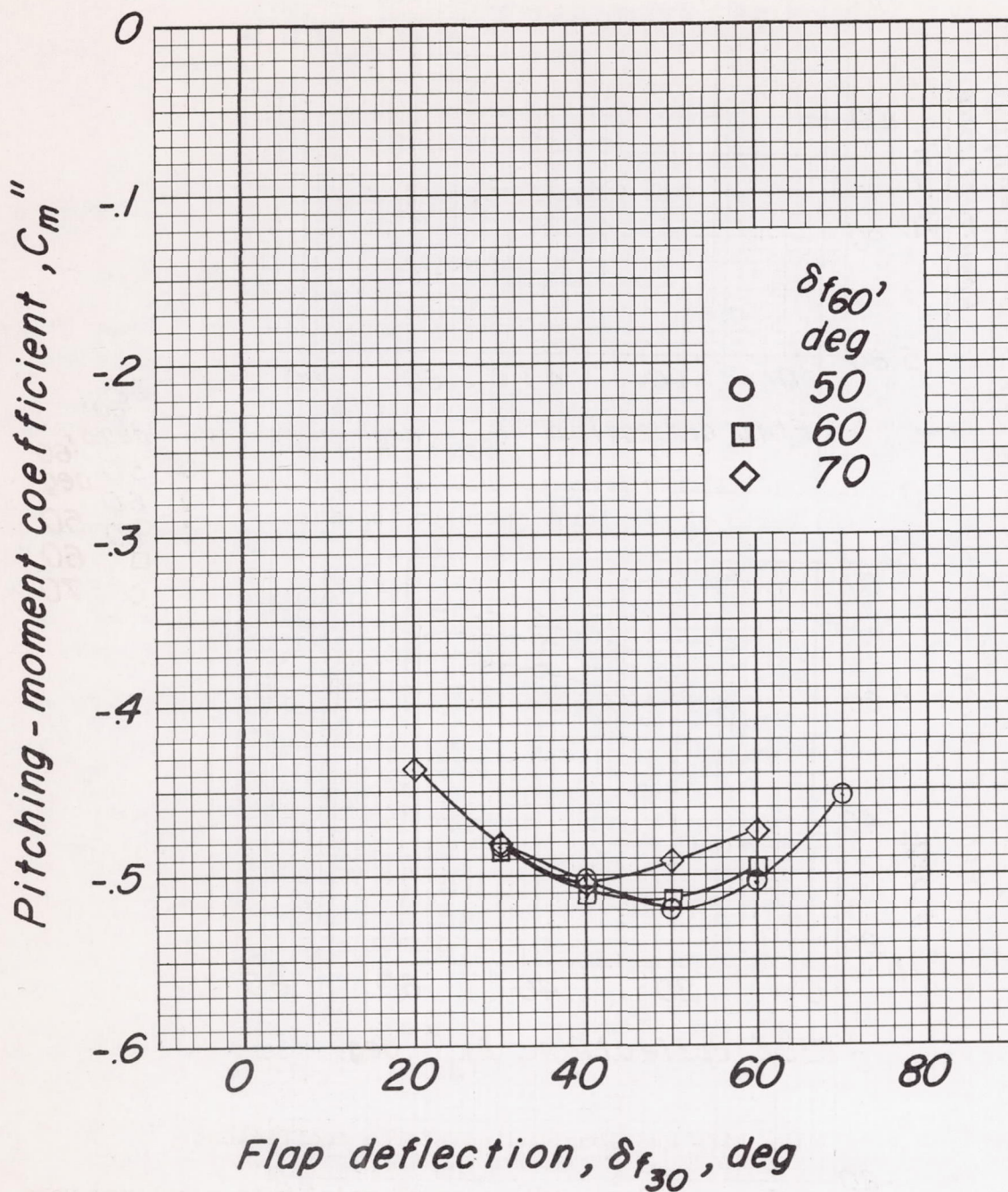

(b) Pitching-moment coefficient.

Figure 8.- Continued.

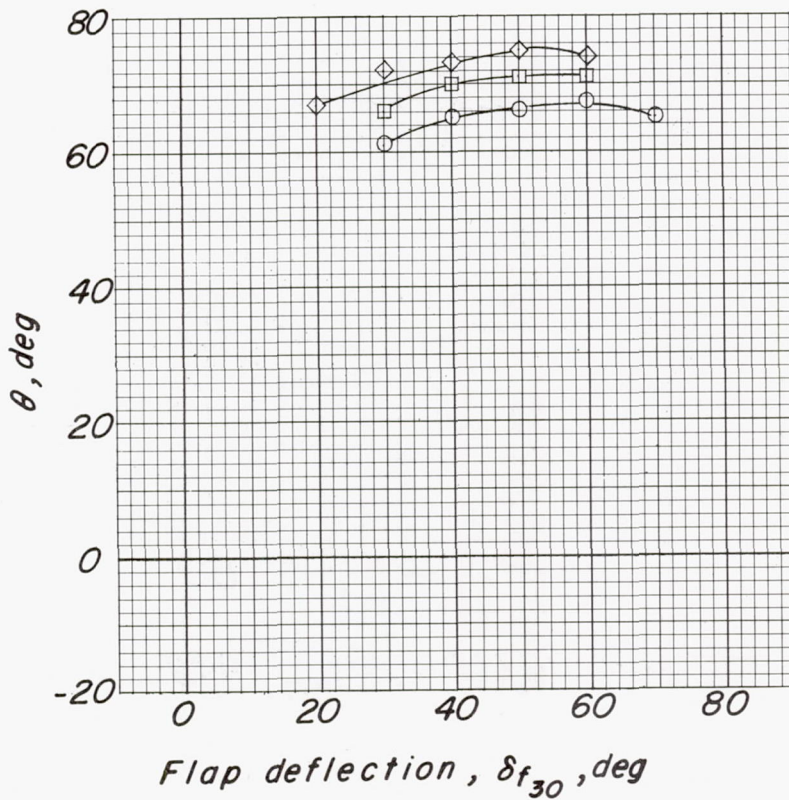
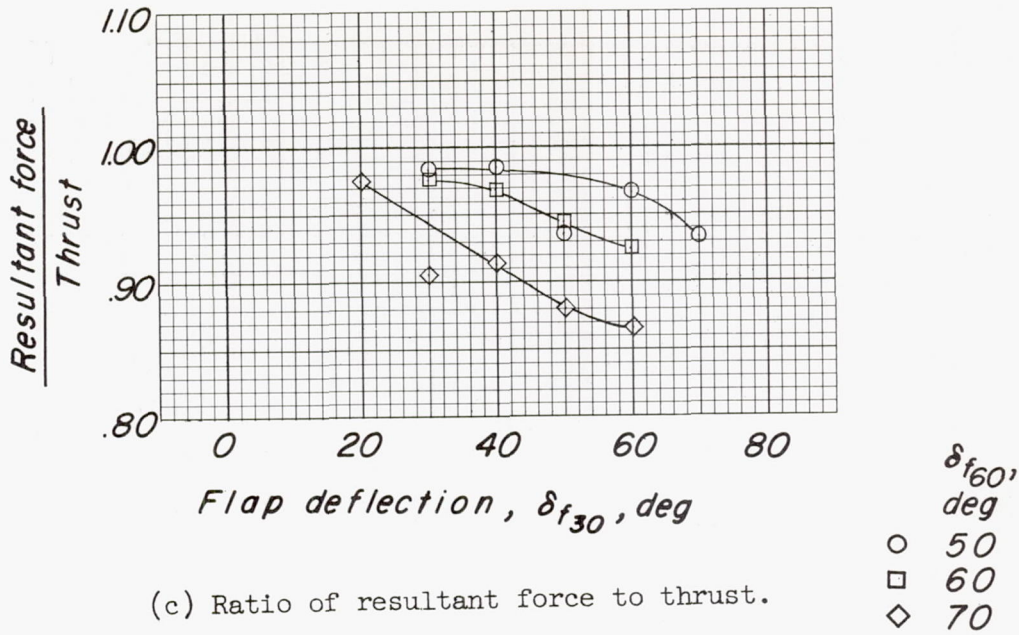
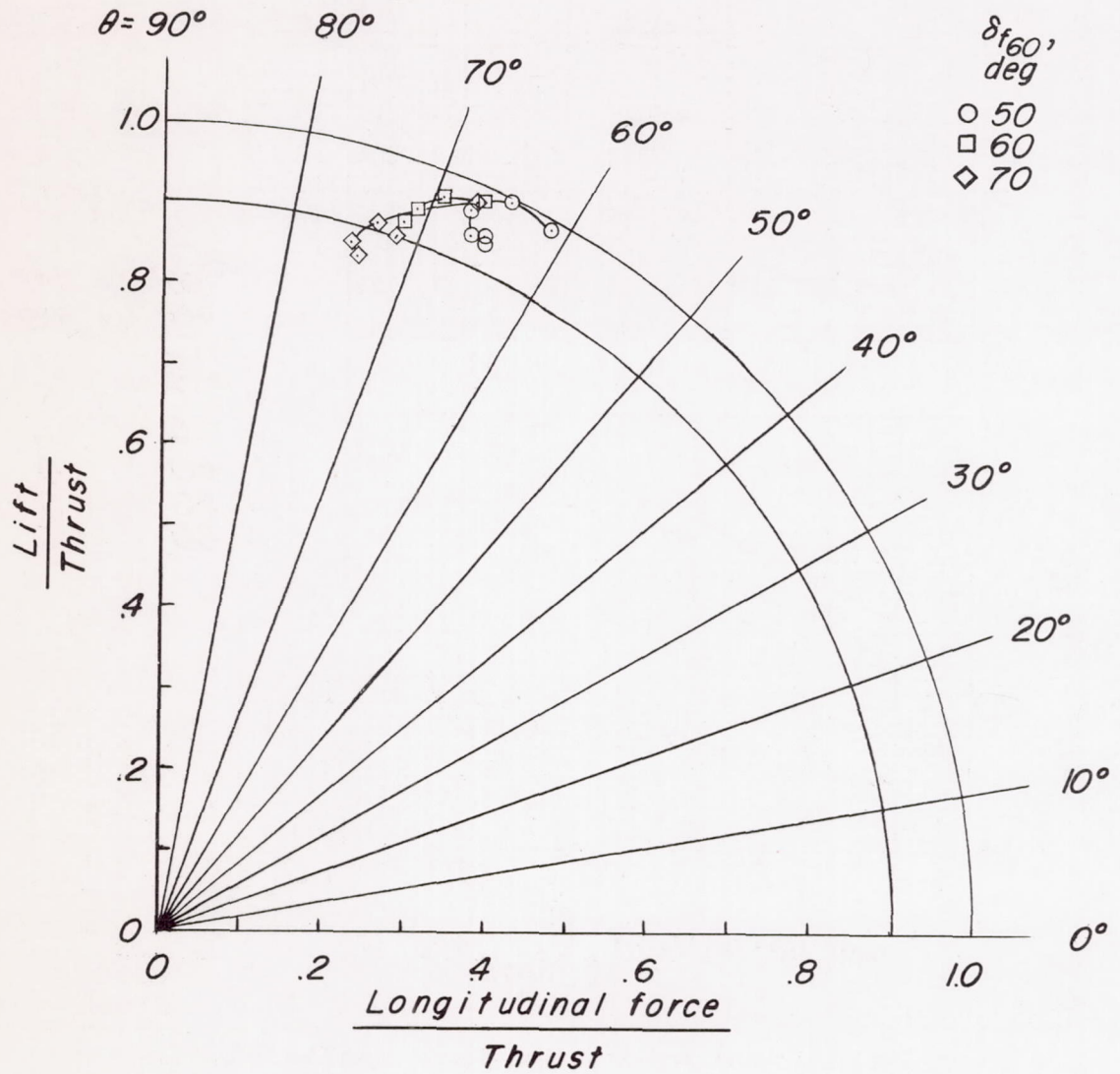
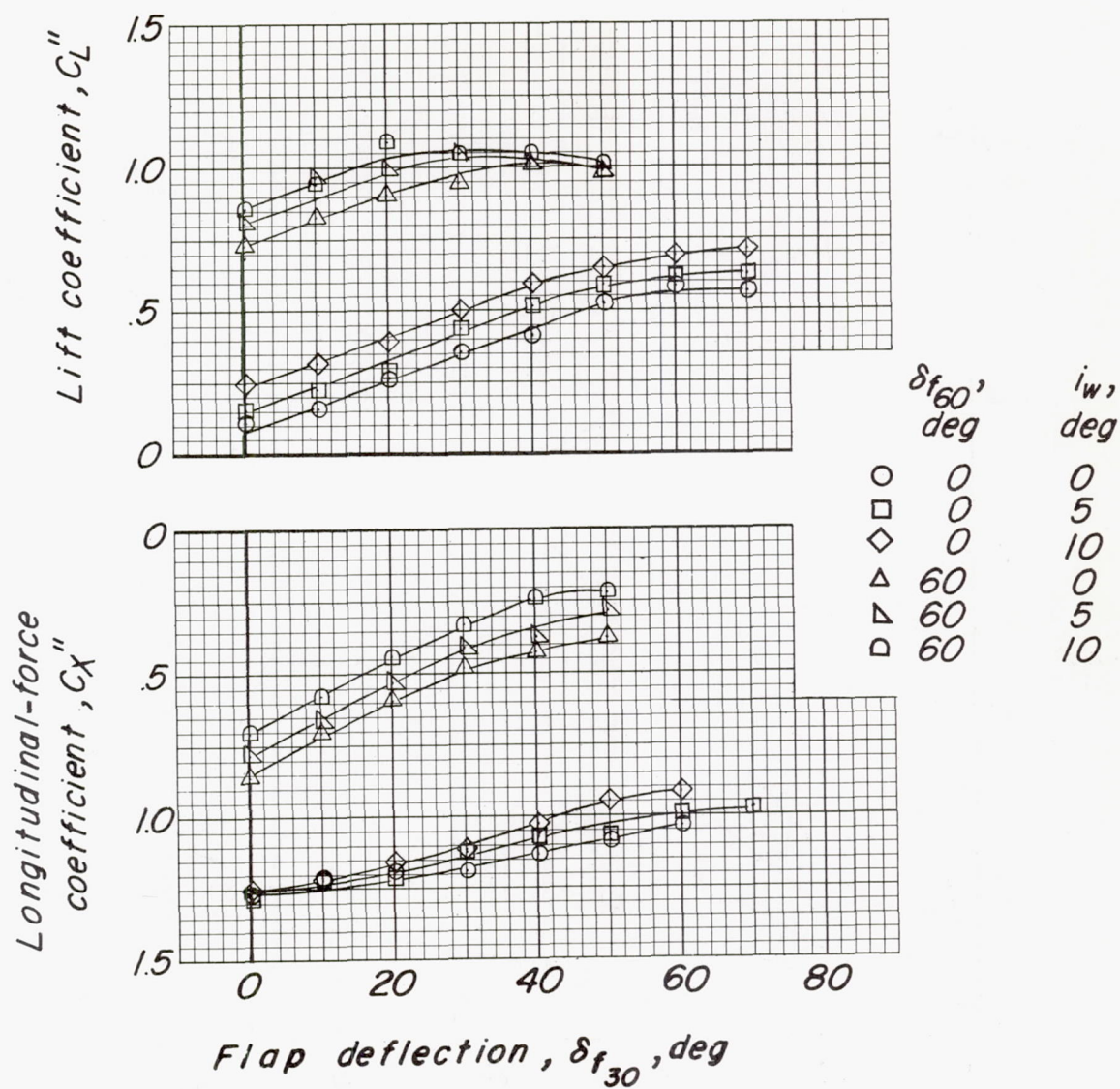

Figure 8.- Continued.



(e) Summary of turning effectiveness.

Figure 8.- Concluded.



(a) Lift and longitudinal-force coefficient.

Figure 9.- Effect of wing incidence on aerodynamic characteristics of wing with slotted flaps in propeller slipstream at zero forward speed. $T_c'' = 1.0$; $\beta_{.75R} = 3.7^\circ$; two propellers.

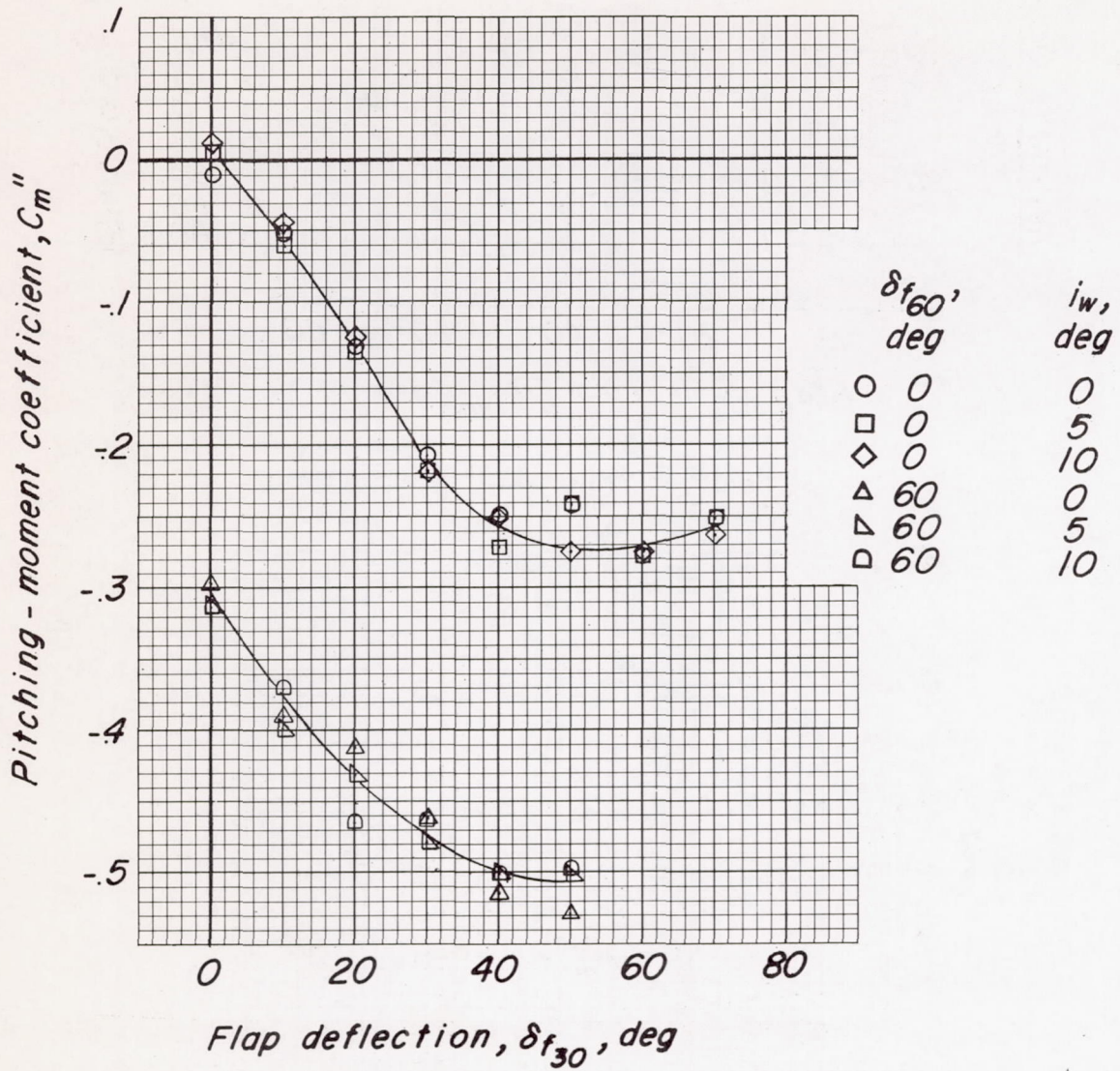

(b) Pitching-moment coefficient.

Figure 9.- Continued.

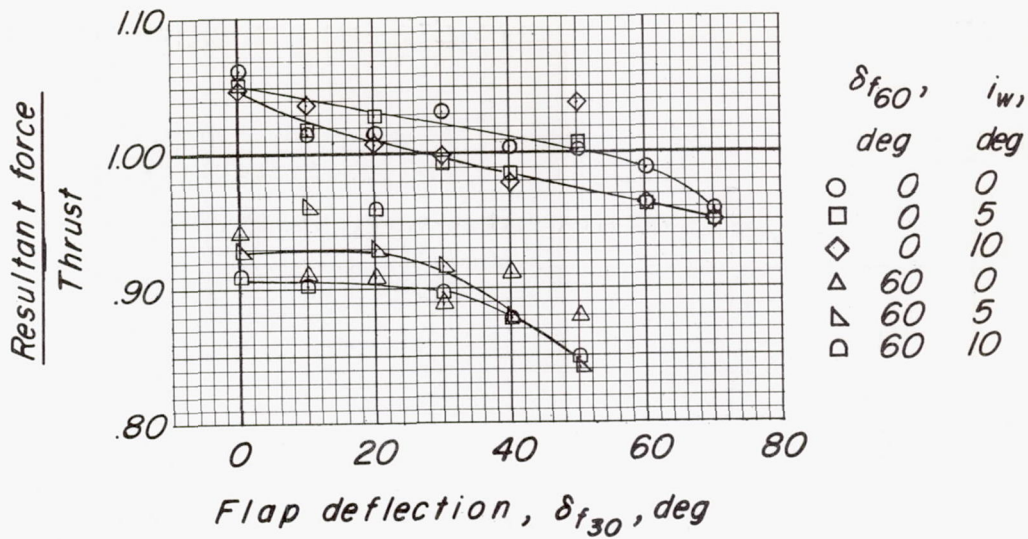

(c) Ratio of resultant force to thrust.

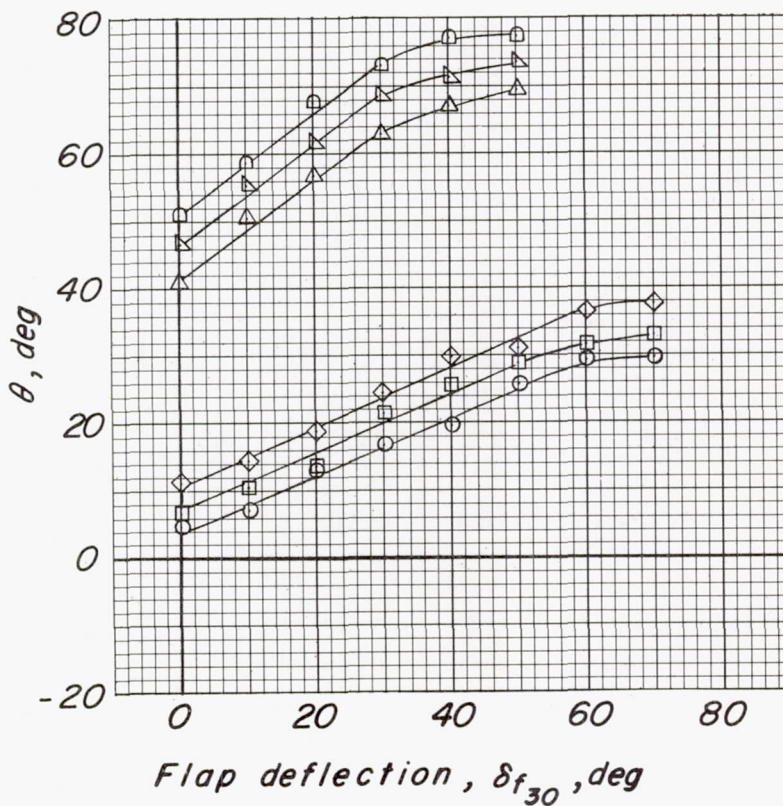

(d) Turning angle.

Figure 9.- Continued.

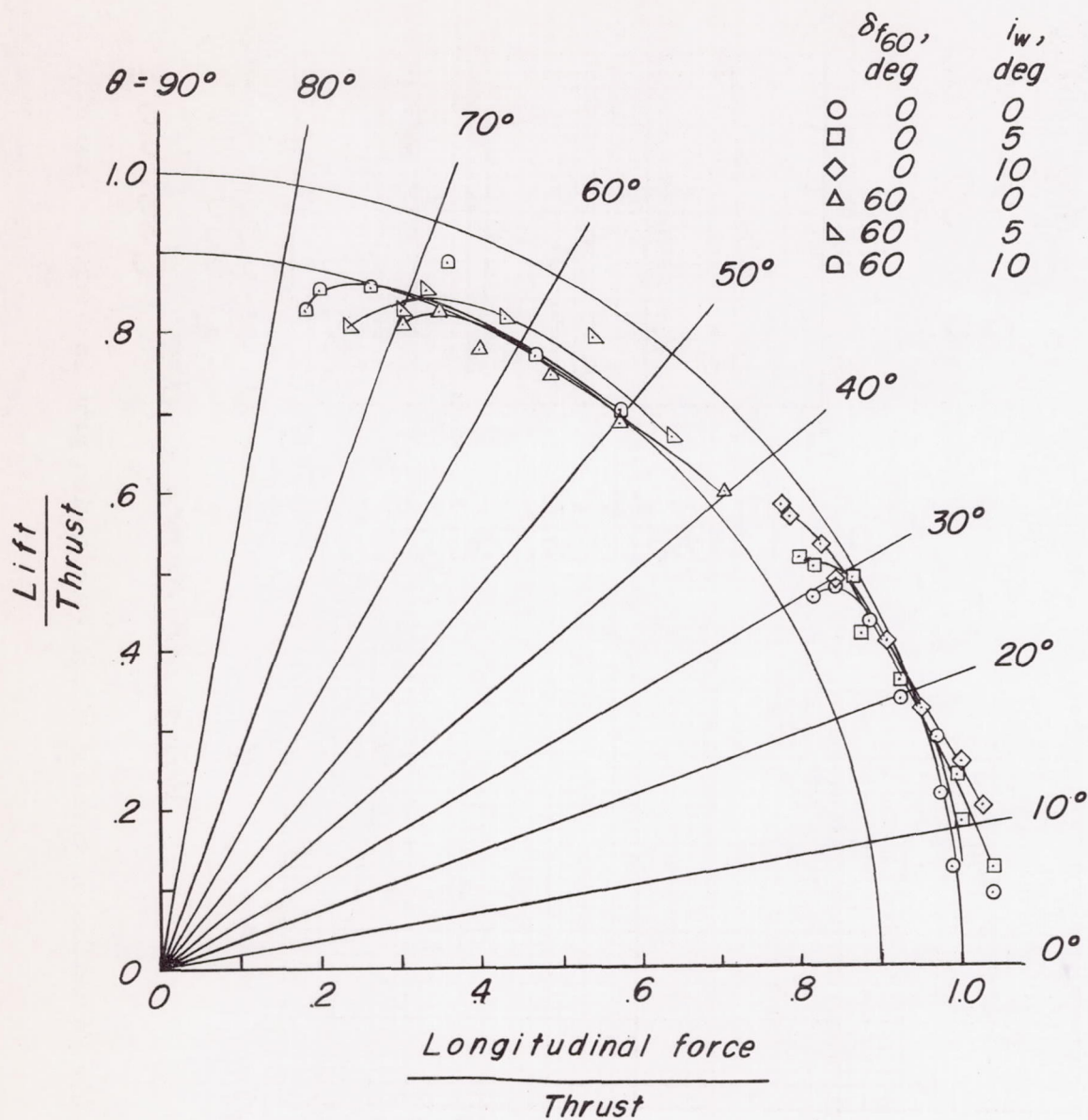

(e) Summary of turning effectiveness.

Figure 9.- Concluded.

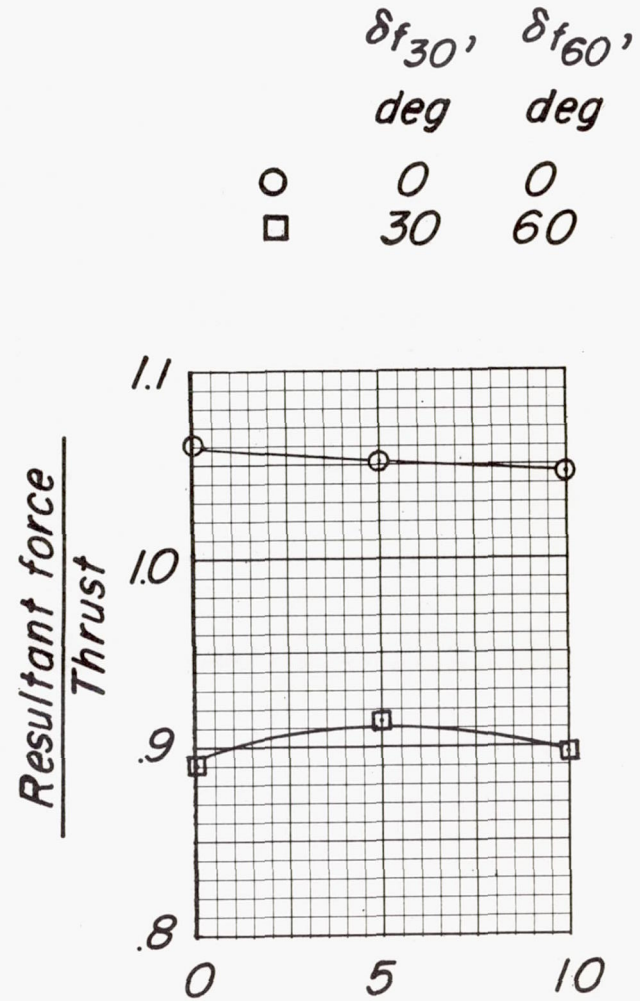
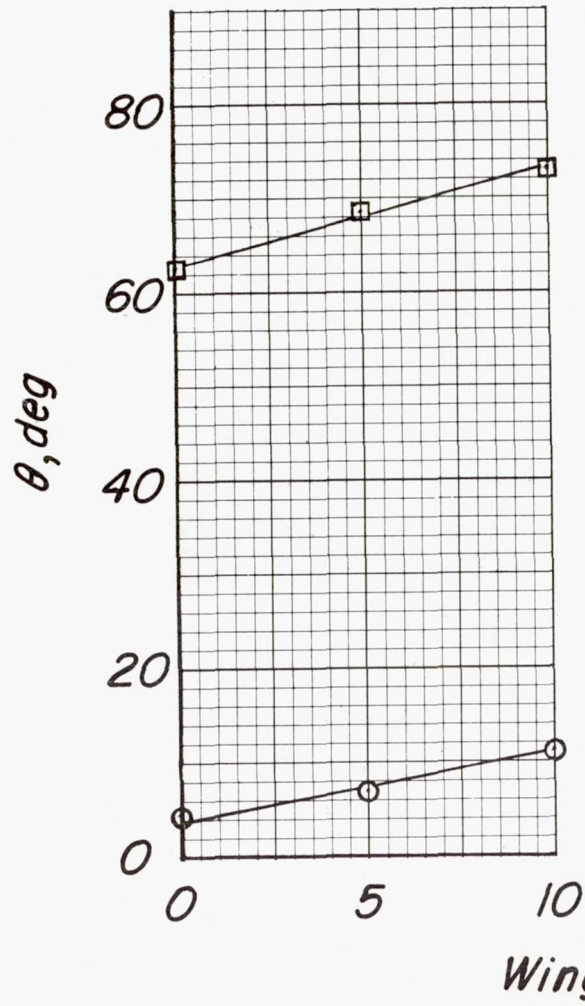
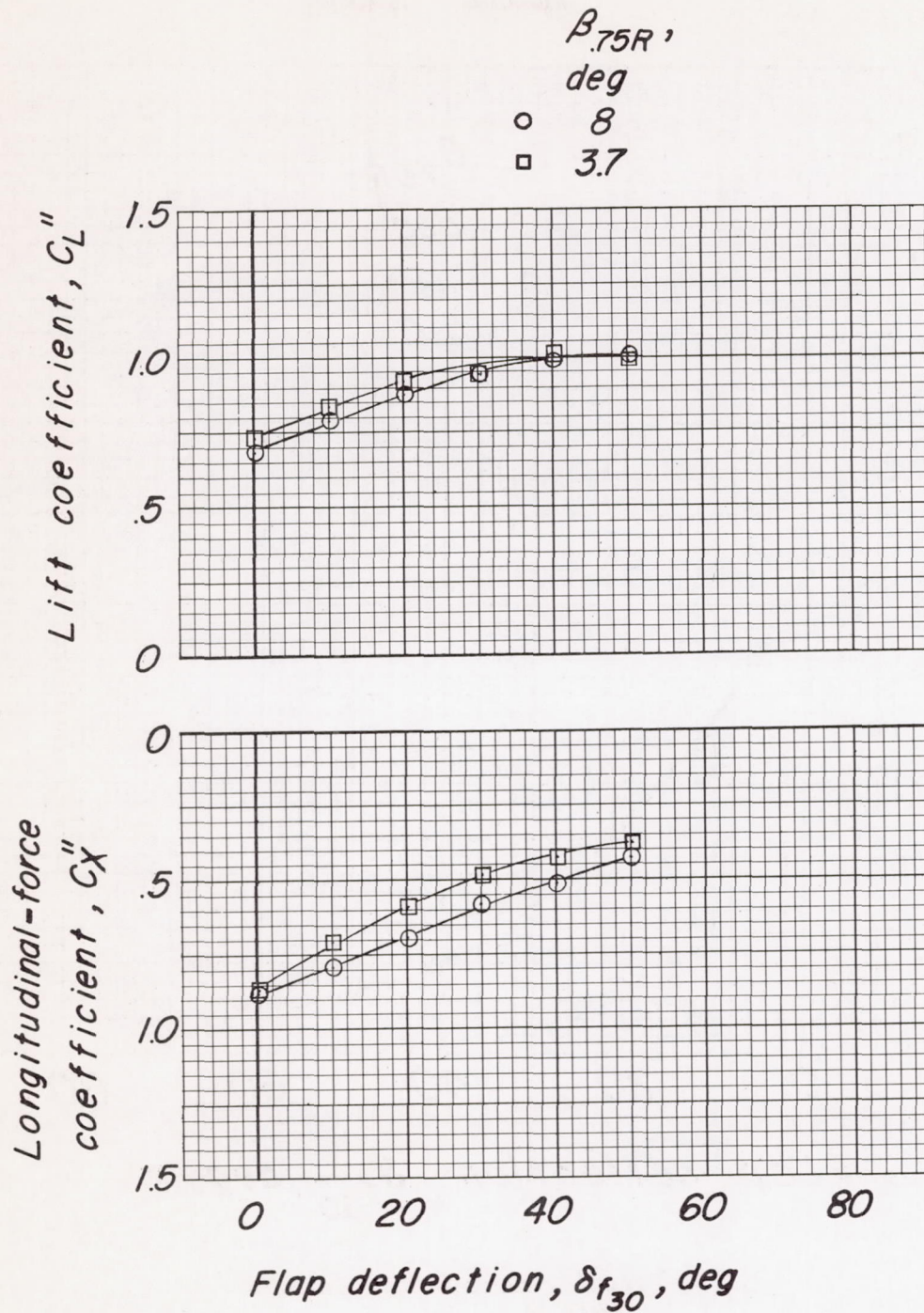
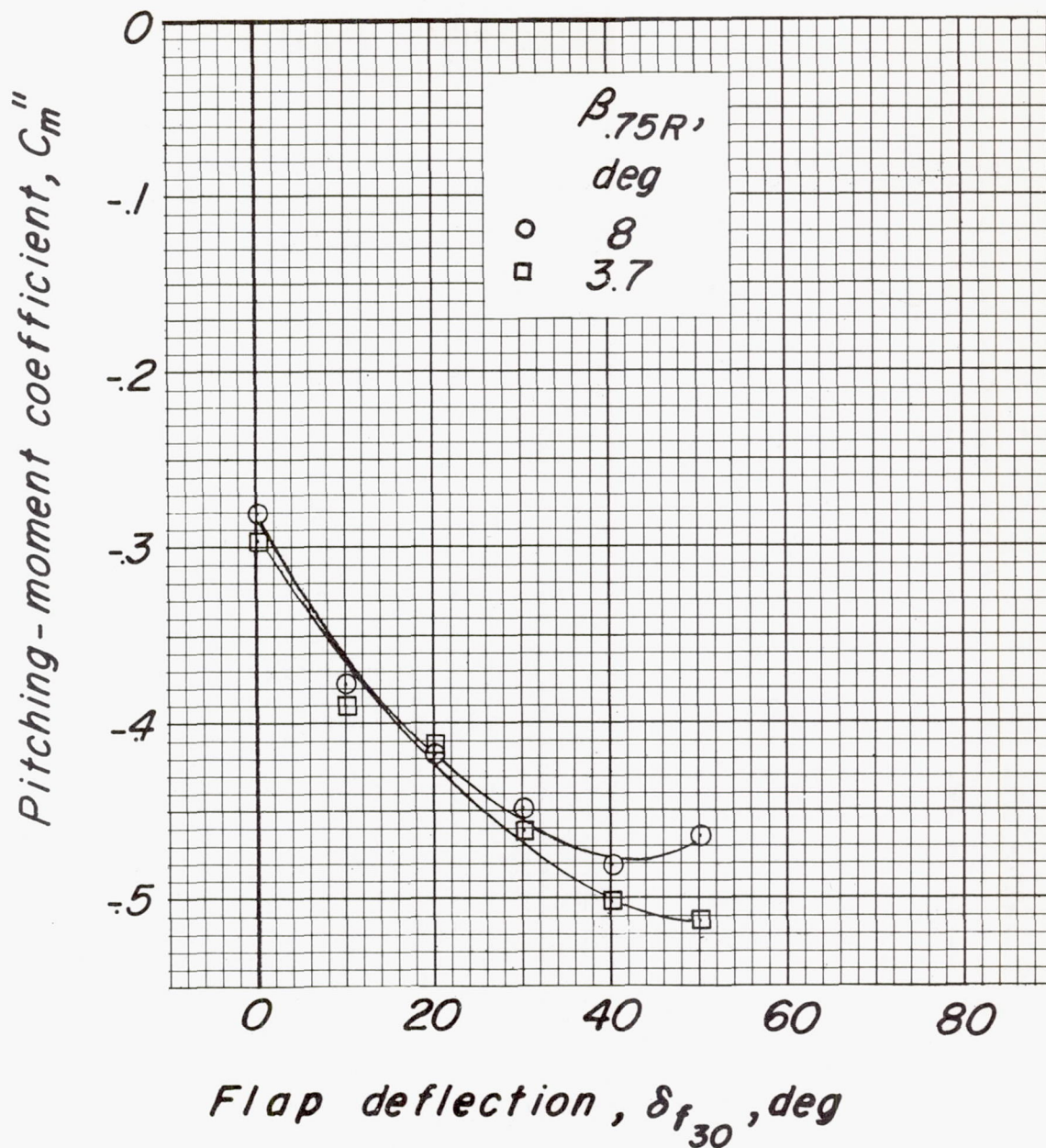

Figure 10.- Variation of turning effectiveness with wing incidence. Vane off.



(a) Lift and longitudinal-force coefficient.

Figure 11.- Comparison of aerodynamic characteristics of wing with slotted flaps for propeller blade angles of 3.7° and 8° . $T_c'' = 1.0$; $\delta_{f_{60}} = 60^\circ$; $i_w = 0^\circ$.



(b) Pitching-moment coefficient.

Figure 11.- Continued.

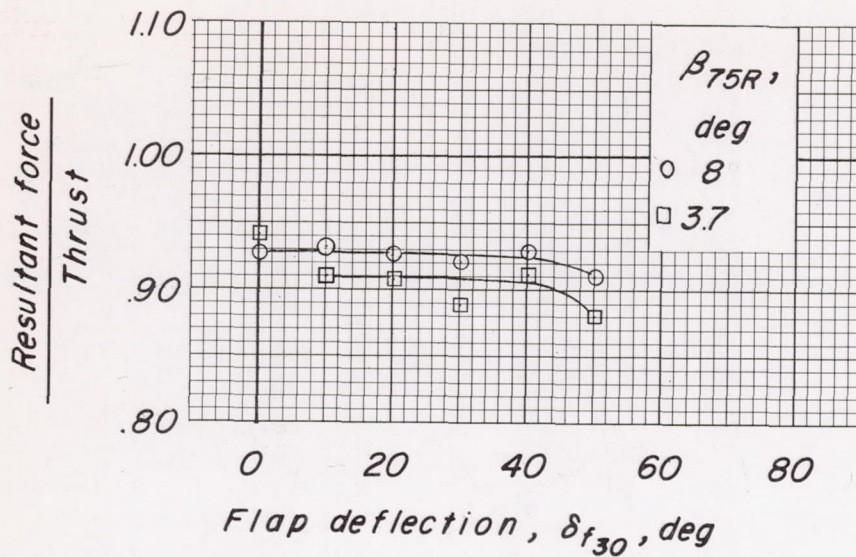

(c) Ratio of resultant force to thrust.

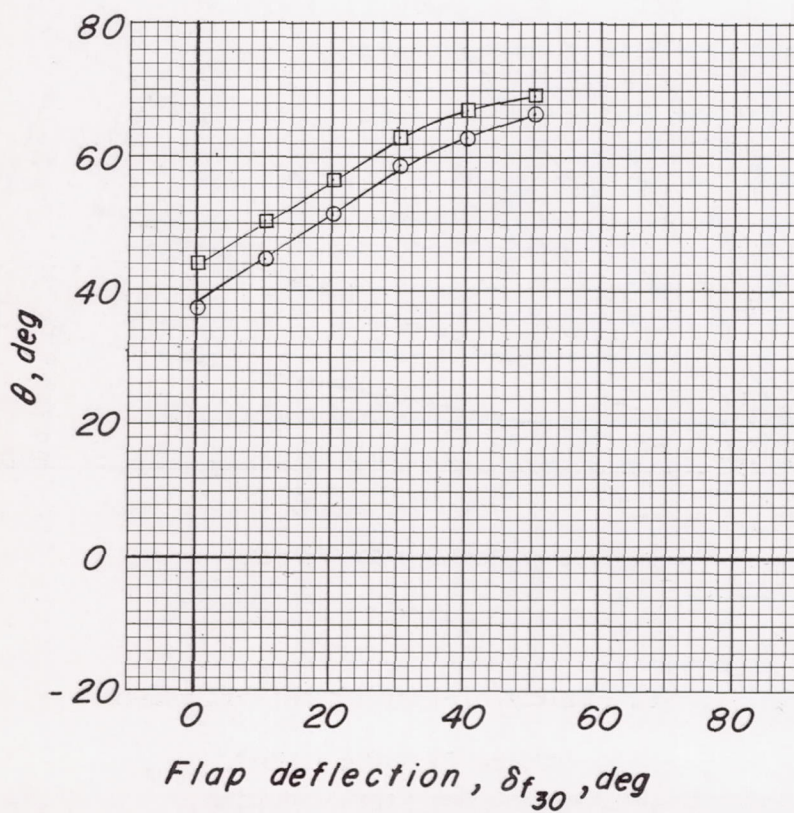

(d) Turning angle.

Figure 11.- Continued.

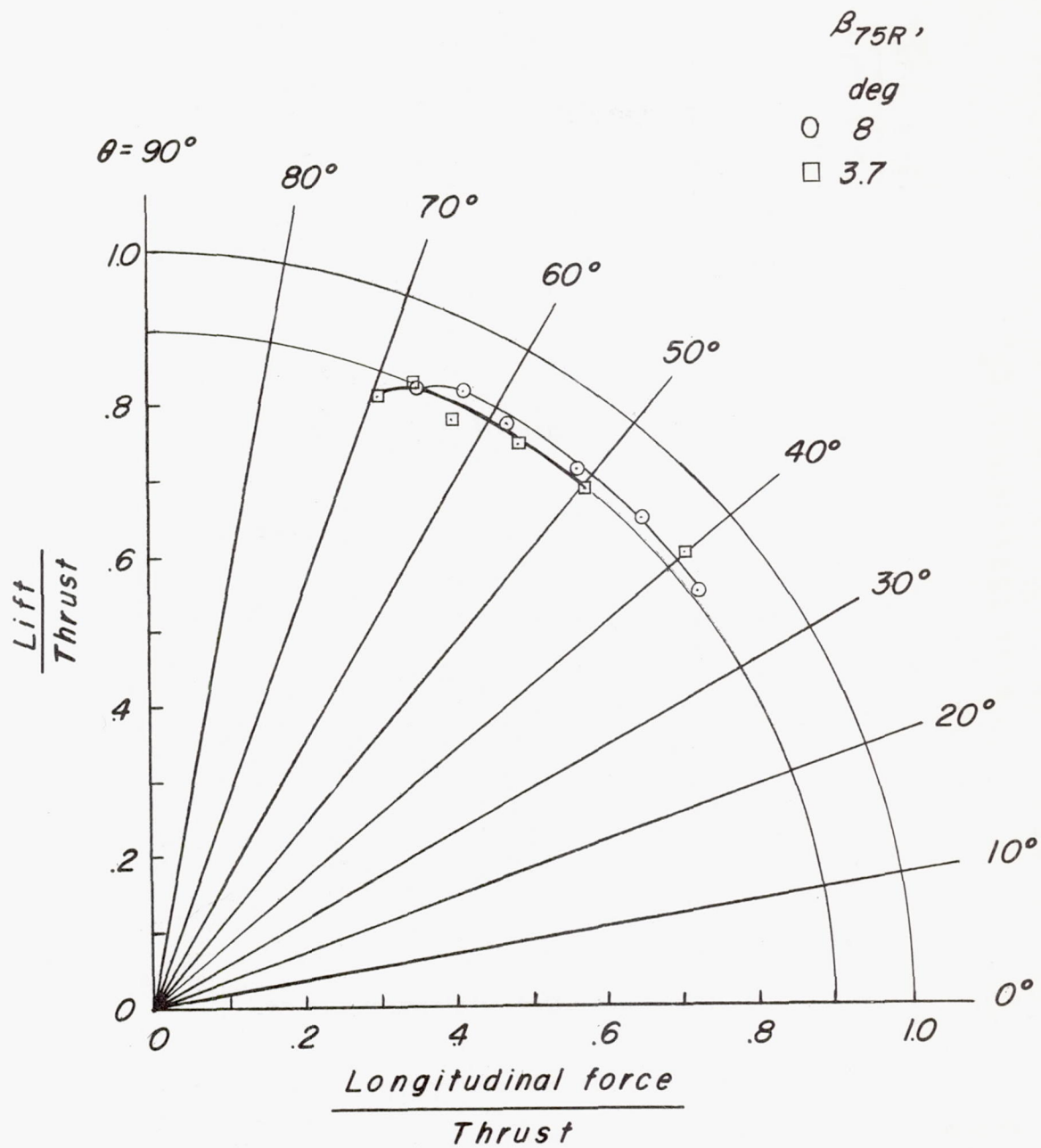

(e) Summary of turning effectiveness.

Figure 11.- Concluded.

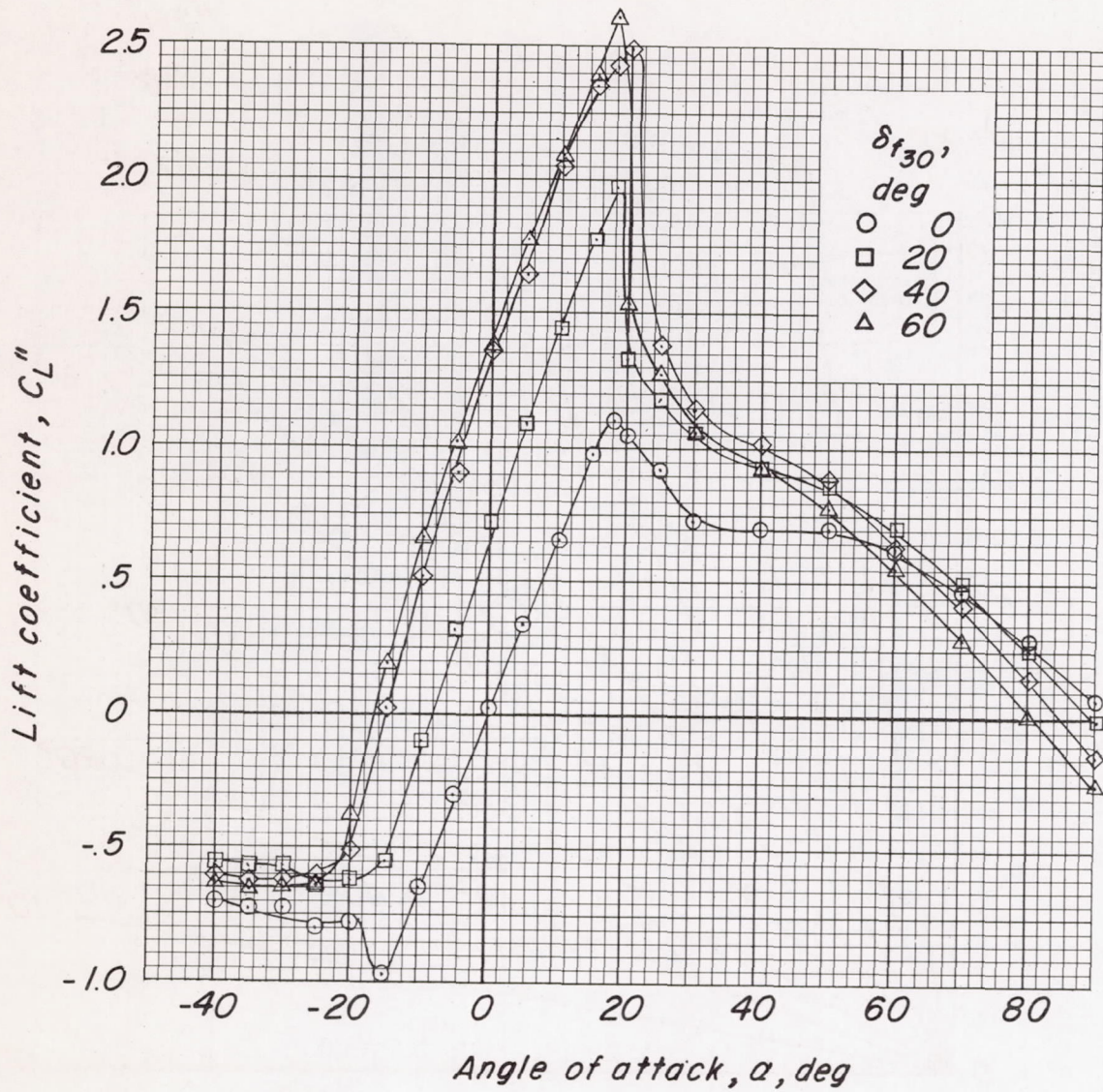

(a) Lift coefficient.

Figure 12.- Effect of flap deflection on aerodynamic characteristics of wing with slotted flaps at forward speed. Propellers and nacelles off; $\delta_{f60} = 0^\circ$.

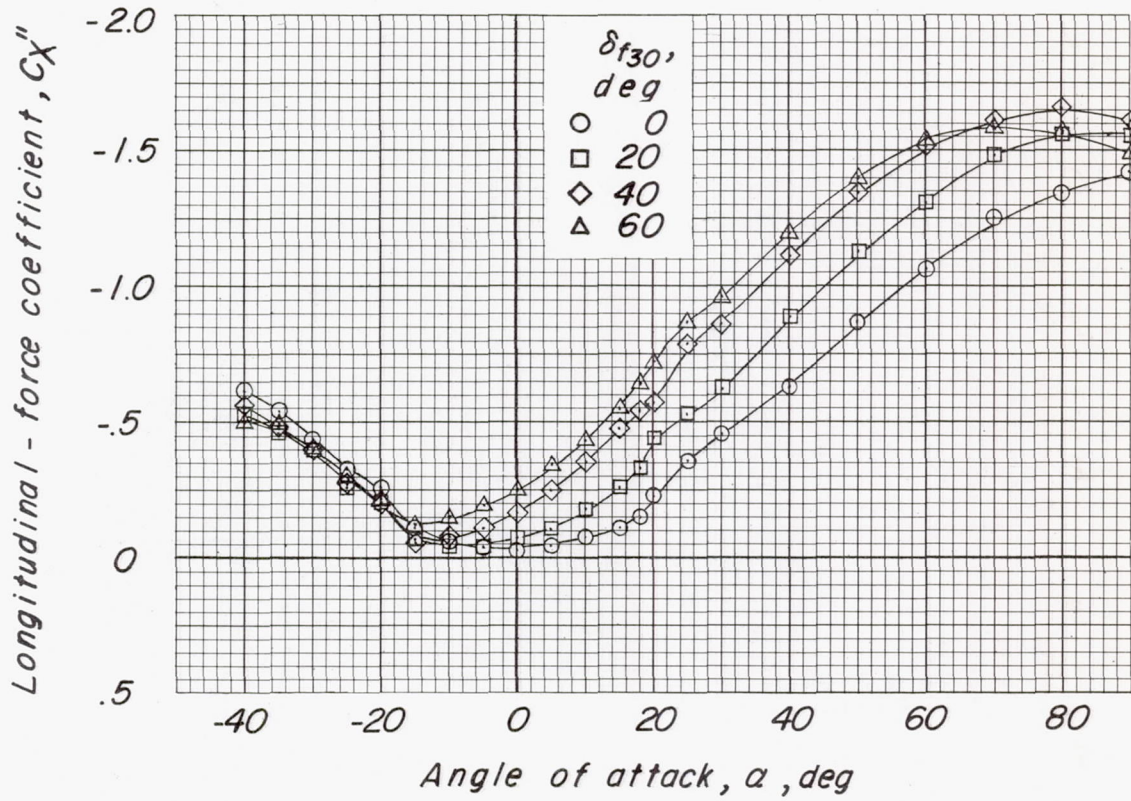

(b) Longitudinal-force coefficient.

Figure 12.- Continued.

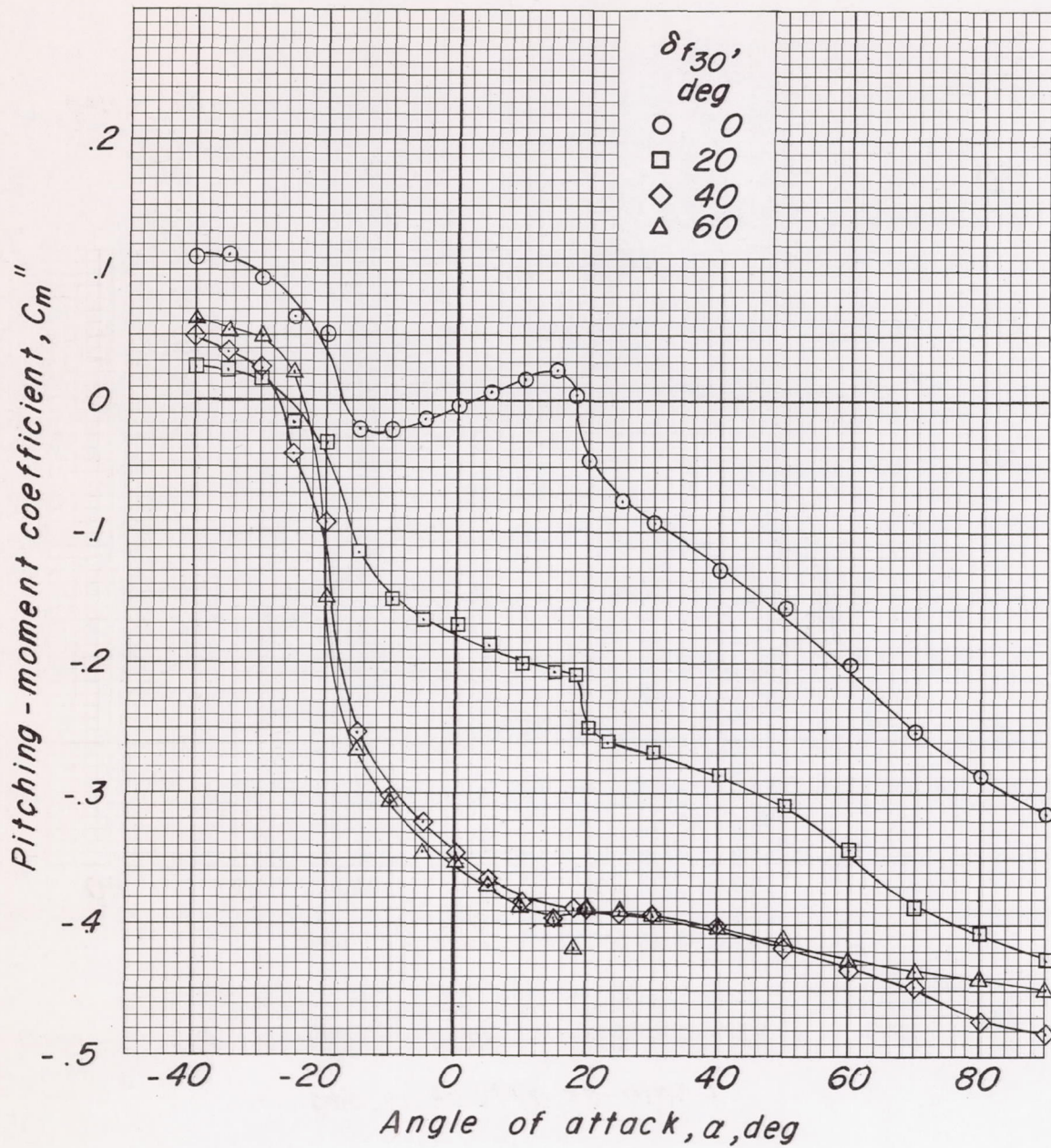

(c) Pitching-moment coefficient.

Figure 12.- Concluded.

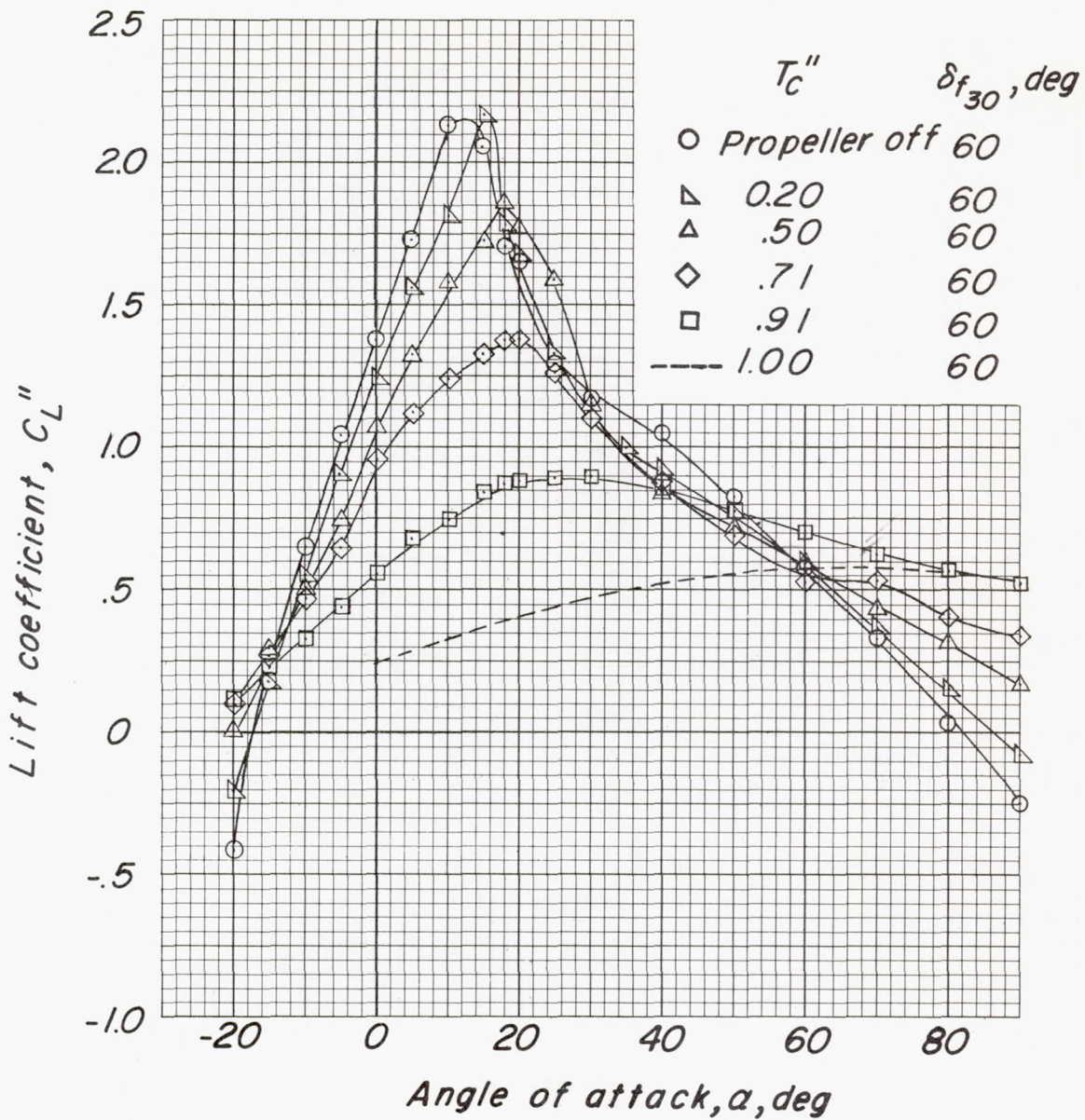

(a) Lift coefficient.

Figure 13.- Effect of slipstream on aerodynamic characteristics of model with forward speed. Inboard propeller and nacelle only; $\delta_{f_{60}} = 0^\circ$.

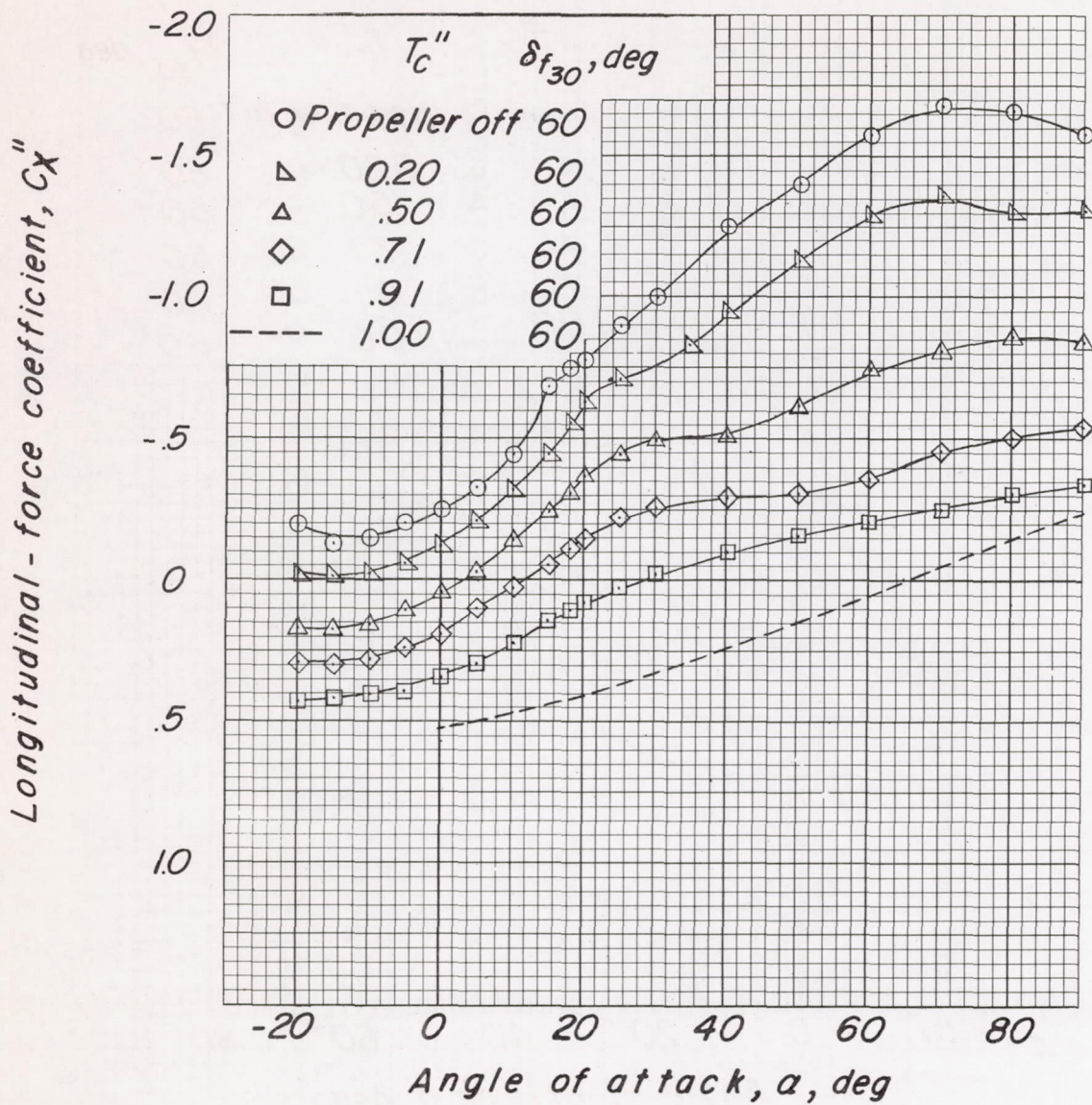

(b) Longitudinal-force coefficient.

Figure 13.- Continued.

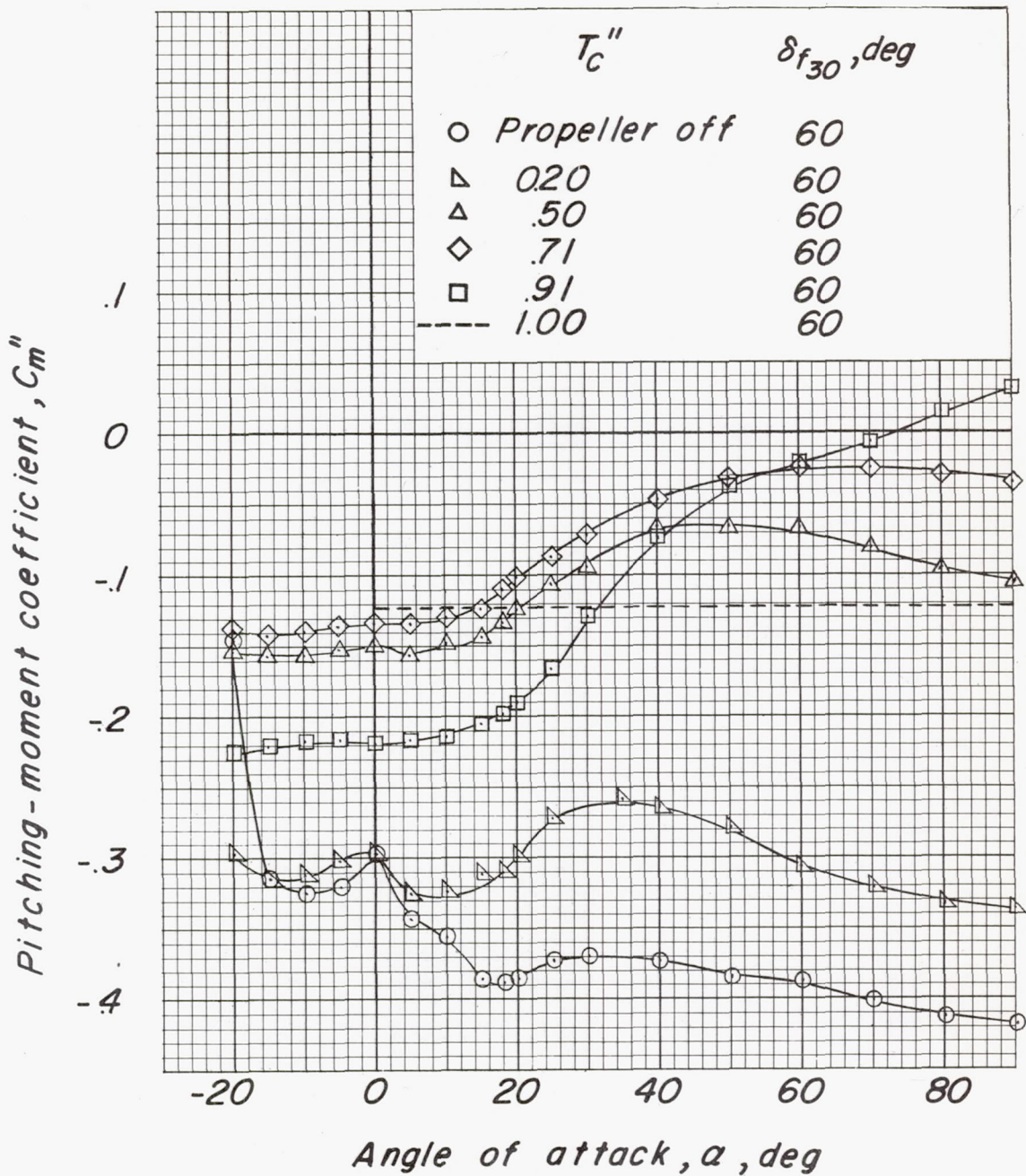

(c) Pitching-moment coefficient.

Figure 13.- Concluded.

Flaps	δf_{30} , deg	δf_{60} , deg	i_w , deg	Vanes	$\beta_{.75R}$, deg
A — Plain	Variable	0	0	None	8
B — Slotted	"	0	0	None	8
C — Plain	"	30	0	None	8
D — Slotted	"	60	0	None	8
E — Plain	"	60	0	Two	8
F — Slotted	"	60	0	One	8
G — Slotted	"	60	10	3.7	

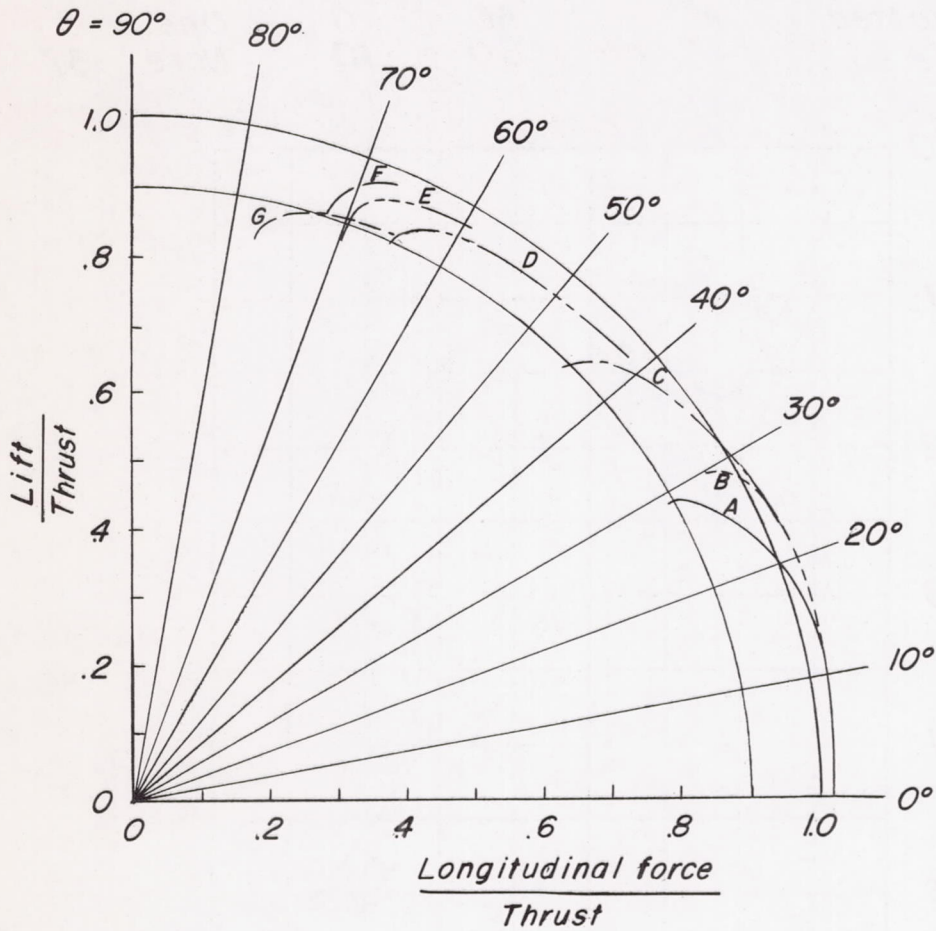

Figure 14.- Comparison of turning effectiveness of plain-flap and slotted-flap configurations. Zero forward speed.

	Flaps	$\delta_{f_{30}}$, deg	$\delta_{f_{60}}$, deg	i_w , deg	Vanes	$\beta_{.75R}$, deg
<u>A</u> ———	Plain	Variable	0	0	None	8
<u>B</u> - - - -	Slotted	"	0	0	None	8
<u>C</u> ———	Plain	"	30	0	None	8
<u>D</u> - - - -	Slotted	"	60	0	None	8
<u>E</u> - - - -	Plain	"	60	0	Two	8
<u>F</u> ———	Slotted	"	60	0	One	8
<u>G</u> - - - -	"	"	60	10	None	3.7

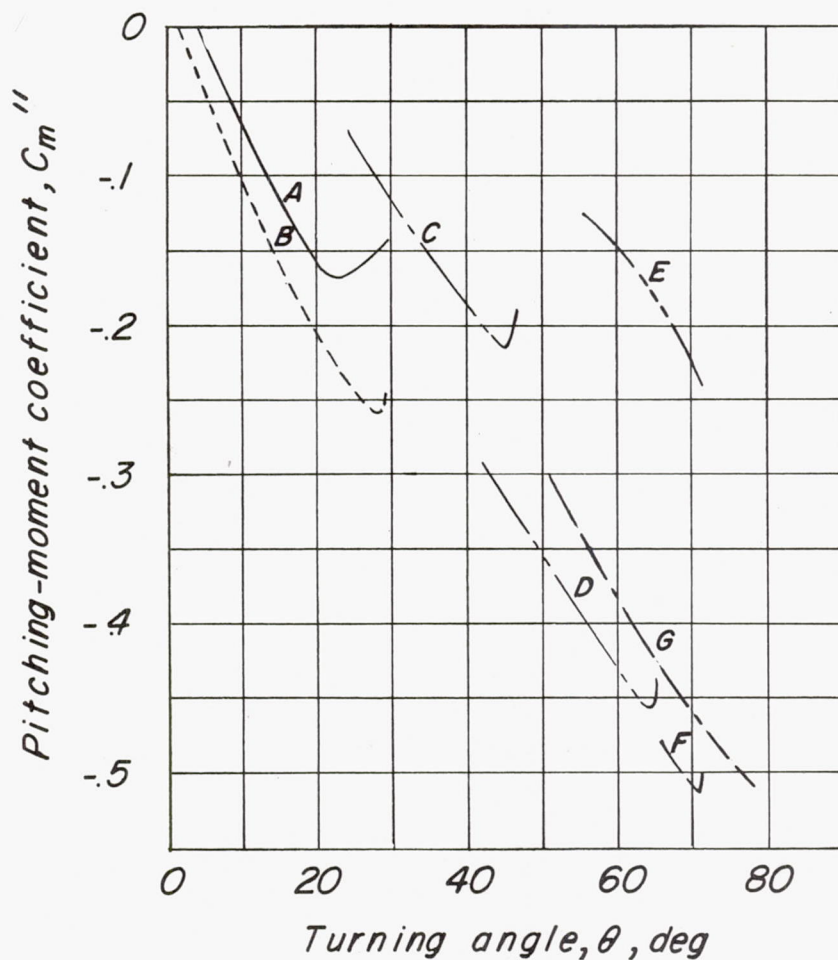

Figure 15.- Comparison of pitching-moment coefficients of plain-flap and slotted-flap configurations. Zero forward speed.