

NACA TN 3924

EPS

NATIONAL ADVISORY COMMITTEE
FOR AERONAUTICS

TECHNICAL NOTE 3924

DISCHARGE COEFFICIENTS FOR COMBUSTOR-
LINER AIR-ENTRY HOLES
II - FLUSH RECTANGULAR HOLES,
STEP LOUVERS, AND SCOOPS

By Ralph T. Dittrich

Lewis Flight Propulsion Laboratory
Cleveland, Ohio

CASE FILE
COPY

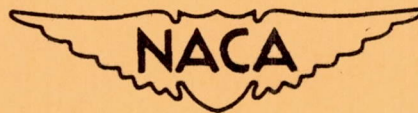

Washington

April 1958

4776



NATIONAL ADVISORY COMMITTEE FOR AERONAUTICS

TECHNICAL NOTE 3924

DISCHARGE COEFFICIENTS FOR COMBUSTOR-LINER AIR-ENTRY HOLES

II - FLUSH RECTANGULAR HOLES, STEP LOUVERS, AND SCOOPS

By Ralph T. Dittrich

SUMMARY

An experimental investigation was conducted to determine discharge coefficients for various types of combustor-liner air-entry holes such as flush rectangular holes, step louvers, and scoops. The data presented herein show the variation in discharge coefficient of each configuration as a function of a dimensionless flow parameter. Within the range investigated, the effect of size or shape of flush holes on discharge coefficient was small compared to the effects of duct stream velocity or pressure ratio across the hole. While the addition of a scoop to a flush hole increased the discharge coefficient only at low values of the flow parameter, the step louver and the thumbnail-type scoop increased discharge coefficients throughout the range of the flow parameter. However, at low values of the flow parameter, the discharge coefficients for scoops and step louvers were affected by boundary-layer conditions of the duct stream. The proximity of multiple flush holes or the wall inclination of a convergent duct had a negligible effect on discharge coefficient.

INTRODUCTION

With the trend toward greater air loading and higher air velocities through turbojet combustors, a knowledge of discharge coefficients for liner wall openings is essential for the design of aerodynamically efficient combustors. Discharge coefficients for flush circular holes with flow parallel to the plane of the hole are presented in reference 1. The present investigation extends the work of reference 1 by presenting discharge coefficients for various other types of liner wall openings such as slots, scoops, and louvers.

With flush circular holes (ref. 1) the effects of hole diameter and wall thickness at the hole on discharge coefficients were small compared with the effects of external parallel flow velocity and pressure ratio across the hole; the effects of duct height, pressure level, and boundary-layer thickness were negligible. Application of the data of reference 1

to calculated flow conditions in a model combustor (ref. 2) indicates that for flush circular liner wall holes the discharge coefficient may vary from approximately 0.2 to 0.6.

A liner design may include other types of air-entry openings that have specific application, such as thumbnail scoops or step louvers (step-wall construction) for wall cooling, longitudinal slots for depth of jet penetration, or scoops over holes for jet direction. Also, such factors as the spacing of holes, both in the longitudinal and transverse directions, and the inclination of the liner wall may affect the discharge coefficient.

Accordingly, the following geometric and flow factors were studied in this investigation: (1) longitudinal slots with length to width ratios ranging from 1 to 16; (2) step louvers ranging in height from $3/32$ to $5/8$ inch, both with and without wall overlap or a corrugated spacer; (3) thumbnail-type scoops $1/8$ and $1/4$ inch high; (4) scoops over holes with scoop face area varying from 0.6 to 1.4 times the hole area; (5) circular flush holes in walls with inclinations of 0° , 8° , and 20° ; (6) step louvers in walls with inclinations of 0° , 8° , and 20° ; (7) multiple circular holes with longitudinal spacings ranging from 1.5 to 5 diameters and transverse spacings from 2 to 4 diameters; (8) external flow velocity of 0 to 420 feet per second; (9) static pressure of external stream approximately 2100 pounds per square foot absolute; (10) airstream temperature approximately 75° F; and (11) pressure drop across hole of 2 to 250 pounds per square foot.

The data for each configuration are presented as a function of a flow parameter. The various types of liner wall openings are compared and discussed.

SYMBOLS

A_d	area of duct cross section, sq ft
A_f	area of louver or scoop face, sq ft
A_f^*	effective area of louver or scoop face, sq ft
A_h	area of flush opening, sq ft
b	width of opening, ft
C	discharge coefficient, ratio of measured to theoretical flow through opening
C_p	discharge coefficient corrected for pressure-ratio effect

C_{p,δ^*}	discharge coefficient corrected for pressure-ratio effects and boundary-layer displacement thickness
h	height of louver or scoop, ft
l	length of rectangular slot, ft
P_d	total pressure of duct stream, lb/sq ft abs
P_f	total pressure of jet stream at face of louver or scoop, lb/sq ft abs
p_d	static pressure of stream in parallel-wall duct, lb/sq ft abs
$p_{d,2}$	static pressure of stream at wall opening in converging duct, lb/sq ft abs
p_j	static pressure of jet stream, lb/sq ft abs
q_d	dynamic pressure of duct stream, lb/sq ft abs
q_j	dynamic pressure of jet stream, lb/sq ft abs
T_d	total or stagnation temperature of duct stream, $^{\circ}R$
V_{bl}	local velocity in boundary layer, ft/sec
V_d	velocity of approach stream in duct, ft/sec
V_j	velocity of jet stream, ft/sec
w_m	measured mass flow of air through opening, lb/sec
w_{th}	theoretical mass flow of air through opening, lb/sec
y	distance normal to duct wall, ft
α	angle of inclination of convergent duct wall, deg
δ	boundary-layer thickness, ft
δ^*	boundary-layer displacement thickness, ft
θ	angle between direction of duct flow and face of air-entry opening, deg
ρ_{bl}	mass density of boundary-layer air, slugs/cu ft
ρ_j	mass density of jet air, slugs/cu ft

APPARATUS

Test Section

The test section used in the present investigation is identical to that described in reference 1. Details of the test section are shown in figure 1(a) with test plate flush with the duct wall and in figure 1(b) as modified for boundary-layer bleedoff. The duct height for all the present tests was 2.23 inches. Room air was drawn through the test section by means of the laboratory low-pressure exhaust system. Air mass-flow rates were measured with a calibrated square-edged orifice.

Instrumentation

Duct static pressure p_d and total pressure P_d were measured at a station approximately $5/8$ inch upstream of the face of scoops or louvers or of the leading edge of flush test holes except for those in inclined walls. Because of the steep static-pressure gradient resulting from inclined duct walls, duct static pressures with these configurations $p_{d,2}$ were measured at a point in the duct wall opposite the opening as indicated in the following sketch:

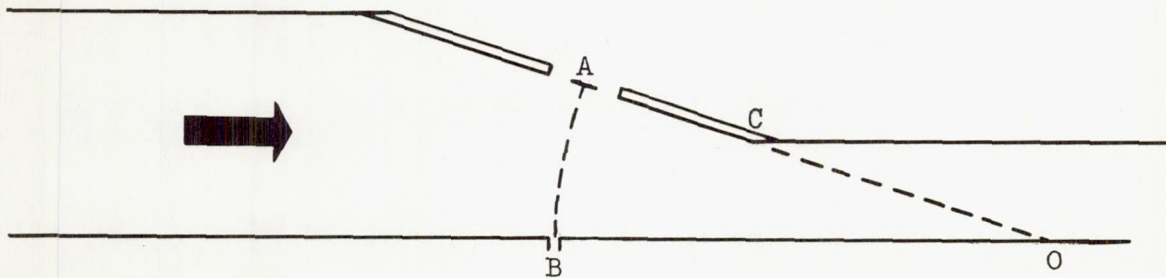

The position of the duct static tap at B was located by extending the line AC to a point O on the opposite wall and making the distance BO equal to AO. Jet static-pressure taps were located on the downstream face of the test plate as shown in figure 1(a). The location of the jet static-pressure taps was not critical in the absence of parallel flow on the downstream face of the test plate.

Air-Entry Configurations

Details of the 32 air-entry configurations investigated are presented in table I. For purposes of comparison the 32 air-entry configurations are divided into six groups on the basis of geometry: flush rectangular

hole (series A), step louver (series B), thumbnail-type scoop (series C), scoop over circular hole (series D), hole or louver in inclined wall (series E), and multiple circular holes (series F). The metal thickness for all configurations was approximately 0.040 inch.

Since the step louver design (series B) is often used as a continuous opening around the circumference of a liner, it was desired to evaluate the side-wall effects of the experimental step louver. Side-wall effects of the experimental step louver may be caused by lateral flow of air across the plane of the side walls whenever the jet and duct velocities are not equal. In an attempt to evaluate such side-wall effects the side walls of some of the experimental step louvers were extended 1 inch upstream of the plane of the opening by a 1/32-inch-thick plate (series B, table I) which formed a fence 1 inch high. The leading and upper edges of the fences were tapered on the outside surfaces only. With these fences the lateral flow of air across the plane of the side walls would be eliminated under all operating conditions. The thumbnail-type scoops (series C) had the form of a segment of a hemisphere with a radius of 0.50 inch.

Two types of scoop-over-hole configurations (series D) were investigated. In the first type the base of the downstream half of the scoop was flush with the perimeter of the hole (series D-1 to D-3), thus forming a smooth flow passage for the air. In the other type the base of the scoop had a radius twice that of the hole.

PROCEDURE

Experiments

Discharge-coefficient data were obtained for each of the 32 air-entry configurations at duct velocities of 0, 50, 150, and 420 feet per second. At each duct velocity condition, the jet velocity was varied up to 650 feet per second. The duct-air total pressure was approximately atmospheric, and the temperature was approximately 75° F for all tests.

Calculations

The discharge coefficient C was calculated as the ratio of the measured mass flow to the theoretical mass flow through the opening w_m/w_{th} . The theoretical mass flow w_{th} was calculated as the product of the jet velocity V_j , the jet density ρ_j , and the area of the opening. The face area A_f was used with step- and thumbnail-type louvers and some of the scoop-over-hole configurations, while the hole area A_h was

used with all scoop-over-hole and flush hole configurations. Assuming isentropic flow, the jet velocity V_j and the jet density ρ_j were determined from compressible-flow relations utilizing the duct total pressure P_d and total temperature T_d and the jet static pressure p_j .

RESULTS

Typical Data

Discharge-coefficient data typical of two different types of liner-wall opening are presented in figure 2 (flush hole, fig. 2(a), and scoop-over-hole, fig. 2(b), configurations A-1 and D-1, respectively). This figure shows the variation in discharge coefficient C with static-pressure ratio p_d/p_j at duct velocities V_d of 0, 50, 150, and 420 feet per second. At zero duct velocity the discharge coefficient for both types of opening varies only slightly with pressure ratio. At duct velocities other than zero the discharge coefficient for flush holes (fig. 2(a)) approaches zero as the pressure ratio decreases toward 1.00, but with the scoop-over-hole configuration (fig. 2(b)) the discharge coefficient is at a relatively high value at pressure ratios in the region of 1.00 and approaches zero at values of p_d/p_j less than 1.00. Also, with the flush hole an increase in duct velocity decreases the discharge coefficient; whereas, with the scoop-over-hole configuration an increase in the duct velocity increases the discharge coefficient.

Zero-Duct-Velocity Data

Data presented in figure 3 show the variation in discharge coefficient with pressure ratio at zero duct velocity (zero crossflow) for 27 of the configurations tested. These data are applicable to the final air-entry opening in a combustor liner where all the air approaching the opening flows through the opening. At a pressure ratio of 1.02, flush holes have discharge coefficients in the range from 0.59 to 0.63, step louvers and thumbnail scoops from 0.67 to 0.79, and scoop-over-hole configurations from 0.49 to 0.61.

Correlation of Velocity Data

The method of correlation presented in reference 1 was extended to satisfy the various configurations of the present investigation. The correlation requires either two or three steps, depending on the type of air-entry configuration.

Flow parameter. - First the data are plotted as a function of a dimensionless flow parameter $(P_d - p_j)/(P_d - p_d)$, which is the ratio of the difference between the total and static pressures of the discharge jet to the difference between the total and static pressures of the duct stream. For incompressible flow this parameter is equal to $(V_j/V_d)^2$ and to q_j/q_d . The typical data of figure 2 are so replotted in figure 4. In this figure the data for the various duct velocities tend to form a common curve. However, for any given duct velocity the data fall above this common curve for the higher values of the flow parameter where the static-pressure ratio p_d/p_j is high. This deviation is considered to be a pressure-ratio effect similar to the increase in discharge coefficient with an increase in pressure ratio shown for the zero-duct-velocity condition in figure 3.

Pressure-ratio correction. - The second step is the correction of discharge coefficients for pressure-ratio effect. To obtain a pressure-ratio correction factor, the zero-duct-velocity data (fig. 3) for 25 configurations were recalculated as the ratio of the discharge coefficient at a given pressure ratio to the discharge coefficient at a pressure ratio of 1.00 (C/C_p). The data were then plotted against a general form of the pressure-ratio term $(p_d + q_d \sin \theta)/p_j$ (fig. 5). For an air-entry configuration having its face normal to the direction of duct flow (such as a scoop or step louver), θ equals 90° , and the general form of the pressure-ratio term reduces to $(p_d + q_d)/p_j$ or p_d/p_j . For a flush hole in a parallel-walled duct, θ equals 0 and the term reduces to p_d/p_j . For flush holes in inclined duct walls, θ equals the angle of inclination of the wall, and q_d equals the dynamic pressure of the duct stream at a plane through the center of the hole. The pressure-ratio correction curve of reference 1 is included in figure 5. Although the data for the various configurations show considerable scatter from the curve of reference 1, this curve, which does represent a mean value, was used for correcting discharge coefficients for all configurations. Discharge-coefficient data were then corrected for pressure-ratio effect by dividing the discharge coefficient C by a correction factor C/C_p determined from figure 5. (The particular data of fig. 4, corrected for pressure-ratio effect, are presented in figs. 13(a) and (d), respectively.)

Boundary-layer correction. - The data presented in figures 6 and 7 were taken specifically for evaluating boundary-layer effects on the discharge coefficients of step louvers and scoops. Reference 1 indicates that boundary layer has a negligible effect on discharge coefficients of flush holes. In figures 6 and 7 both louver height h and boundary-layer thickness δ of the duct stream were varied independently. These

figures show that a variation in either louver height or boundary-layer thickness may affect not only the discharge coefficient but also the value of the flow parameter at zero airflow through the louver.

In an attempt to correct the louver data for boundary-layer effects, the discharge coefficients of figures 6 and 7 were recalculated on the basis of effective face area of louver A_f^* as determined by $A_f^* = (A_f - b\delta^*)$. The boundary-layer displacement thickness

$$\delta^* = \frac{1}{\rho_j V_j} \int_0^{\delta} (\rho_j V_j - \rho_{bl} V_{bl}) dy$$

was determined from pressure profiles (fig. 8) measured at the face of the 0.623-inch-high louver at various flow conditions. Figure 8 shows that the boundary-layer thickness at the face of a louver varies not only with the initial boundary layer of the duct stream but also with the flow through the opening. Figure 9 shows the variation in δ^* with the flow parameter for the three duct boundary-layer conditions investigated. Pressure profiles shown in figure 8(b) and boundary-layer displacement-thickness values shown in figure 9 for duct boundary-layer thickness of 0.10 inch apply to all configurations of this investigation except B-11, B-12, and E-2 to E-5.

The data of figures 6 and 7, corrected for pressure-ratio effects and boundary-layer displacement thickness, are replotted in figures 10 and 11, respectively. The corrected discharge coefficient C_{p,δ^*} at a flow-parameter value of 1.0 is approximately 0.95 for all louver heights and boundary-layer conditions investigated. At flow-parameter values greater than approximately 4.0, a decrease in louver height increases the discharge coefficient slightly (fig. 10).

Flow-parameter values at zero airflow through the opening are of interest because they indicate the lower limit of the flow range for a given configuration. Variation in this value of the flow parameter for the various louver and scoop configurations investigated is shown in figure 12 as a function of louver or scoop height. Although the data show considerable scatter from the faired curve, a definite trend is indicated. Theoretically, for an opening having zero height (such as a flush hole) the lower limit of the flow range would be at a flow parameter of 1.0; conversely, if there were no wall effect (a louver or scoop detached from the wall and functioning as a Pitot tube) the limiting value of the flow parameter for a louver or scoop would be zero.

Correlated Data

The discharge-coefficient data for the various configurations were corrected for pressure-ratio effects and for boundary-layer displacement thickness, where applicable, and are plotted as a function of the flow

parameter in figure 13. Included in these figures are discharge coefficients at zero duct velocity determined by extrapolation of the applicable faired curves in figure 3 to a pressure ratio of 1.00. These data are plotted (fig. 13) at values of the flow parameter obtained from the approximate relation

$$\frac{P_d - p_j}{P_d - p_d} \approx \left(\frac{A_d}{CA_h} \right)^2$$

DISCUSSION

Rectangular Slots

Effect of slot size. - Faired curves of the discharge coefficients for five rectangular slots (configurations A-1 to A-5) are compared with that of a 0.750-inch-diameter flush circular hole (configuration E-1) in figure 14. In general, rectangular slots with their major dimension parallel to the direction of flow have discharge coefficients slightly greater than those for circular or square holes. As with circular holes (ref. 1), hole width has little effect on discharge coefficients for widths greater than 0.5 inch (compare configuration A-2 with A-4).

Effect of length-to-width ratio. - Figure 14 shows that an increase in the length-to-width ratio of a rectangular slot increases the discharge coefficient slightly throughout the range of the flow parameter.

Step Louvers

Discharge coefficients C_{p,δ^*} for step louvers (figs. 15 to 17) are maximum at a flow parameter of 1.0 and decrease gradually at values greater and sharply at values less than 1.0. The minimum value of the flow parameter for a given configuration was shown in figure 12 to be a function of louver height h .

Effect of louver height. - Faired curves representing data for step louver heights ranging from 0.104 to 0.623 inch are compared in figure 15. An increase in louver height may either decrease or increase the corrected discharge coefficient, depending on whether the value of the flow parameter is greater or less, respectively, than approximately 4.0.

Effect of louver overlap and spacer. - Louver wall overlap or the use of a corrugated spacer within this overlap is shown in figure 16 to have only a small effect on the corrected discharge coefficient for louvers approximately 0.10 and 0.25 inch high.

Effect of louver width. - Step louvers are often designed as a continuous opening around the circumference of a combustor liner. In order to determine the magnitude of the side-wall effects of the 1-inch-wide experimental step louver, data were obtained for louvers both with and without side-wall extensions. Extending the side walls upstream of the plane of the louver opening was intended to prevent the lateral flow of air across the plane of the side walls at the opening. Comparison of data for configurations B-2 and B-3 (fig. 17) indicates that for louvers up to 0.25 inch high side-wall effects are negligible. The data, therefore, should be applicable to continuous step louvers.

Thumbnail-Type Scoops

Corrected discharge coefficients for thumbnail-type scoops (fig. 18) are somewhat lower than those for step louvers at low values of the flow parameters. As with step louvers, the effect of scoop height on the corrected discharge coefficient is small.

Scoops over Circular Holes

Four different scoop-over-hole configurations were investigated. For three of the configurations the downstream half of the scoop coincides with the perimeter of the hole, the scoops differing in face area relative to hole area; for the fourth configuration the base radius is twice that of the hole. The hole diameter was 0.750 inch for the four configurations. Although discharge coefficients are usually based on the smallest flow area of the configuration, for purposes of comparison the calculations for configurations D-1 and D-2 are based on hole area (a larger area) in figure 19 and on scoop face area (the smallest area) in figure 20.

Effect of scoop face area. - Corrected discharge coefficients for scoops over circular holes are compared with those of a flush circular hole (configuration E-1) in figure 19. These data are corrected for pressure-ratio effect but not for boundary-layer displacement thickness, since the discharge coefficient is based on the hole area rather than on the face area of the scoop. These data, therefore, are comparable with those of a flush circular hole.

Figure 19 shows that increasing scoop face area by increasing scoop height (configurations D-1, D-2, and D-3) not only increases the corrected discharge coefficient throughout the flow range but extends the flow range to lower values of the flow parameter. This comparison indicates the magnitude of the effect of scoop face area on discharge coefficients based on flush hole area. The addition of an 0.891-inch-high scoop to a flush hole extends the flow range from a flow parameter of 1.0 (configuration E-1) to values less than 0.05 (configuration D-3) because of ram

pressure (fig. 19). At flow-parameter values greater than 20 a scoop face area of approximately 1.4 times the hole area (configuration D-3) is required to attain a discharge coefficient equal to that of a flush hole (configuration E-1).

Effect of size of scoop base. - The effect of increasing the size of the base of a scoop from one that coincides with the perimeter of the hole to one having a radius twice that of the hole, also shown in figure 19 (compare configuration D-3 with D-4), is to decrease the discharge coefficient throughout the flow range. Although these two configurations had approximately equal face areas, the reduced height of configuration D-4 in conjunction with boundary-layer effects resulted in a reduced flow range at low values of the flow parameter.

Comparison with thumbnail-type scoop. - Because of geometric similarities, the discharge coefficients of a thumbnail-type scoop are compared with those of scoop-over-hole configurations in figure 20. Since the discharge coefficients $C_{p,\delta}^*$ in figure 20 are based on scoop face area, they are corrected for both boundary-layer displacement thickness and pressure-ratio effect.

The comparison shows that the thumbnail-type scoop has the higher discharge coefficient throughout its flow range. A study of the data indicates that the difference in discharge coefficients for the three configurations shown is a function of the flush hole area (in the plane of the wall) relative to the scoop face area A_h/A_f . The effect of scoop height on the flow range at low values of the flow parameter is again apparent.

Holes and Louvers on Inclined Surfaces

In many combustor designs the walls of the liner and the outer shell are not parallel. The effect of inclined walls on the discharge coefficient of a flush circular hole and a step louver is shown in figure 21.

Flush circular hole. - Corrected discharge coefficients for a 0.750-inch-diameter flush hole mounted on inclines of 0° , 8° , and 20° are compared in figure 21(a). Discharge coefficients are practically unaffected by wall inclinations up to 20° except for a small ram effect at low flows that tends to decrease the value of the flow parameter for the 20° angle.

Step louvers. - Similarly, the discharge coefficients of a 0.105-inch-high step louver (with no overlap) mounted on inclines of 0° , 8° , and 20° are compared in figure 21(b). Since the pressure profiles obtained (fig. 8) are not applicable to flow in a convergent duct, the

discharge coefficients in figure 21(b) are not corrected for boundary-layer displacement thickness. Also, the effects of the side-wall extensions for louvers mounted on an incline were not investigated. The differences in discharge coefficient shown for the three configurations may be partially due to variations in boundary-layer conditions. However, an increase in inclination angle tends to increase the flow range at low values of the flow parameter.

Multiple Flush Holes

The effect of proximity of multiple flush holes on discharge coefficient for both in-line and side-by-side arrangements is presented in figure 22. The data presented indicate the over-all discharge coefficient for a given multiple-hole configuration rather than for individual holes of that configuration.

Holes in line. - Faired curves representing corrected discharge coefficients for two 0.750-inch-diameter flush holes spaced 3.750 and 1.125 inches apart, center-to-center, in a longitudinal direction are compared with that of a single hole in figure 22(a). The results indicate that a reduction in longitudinal spacing of circular holes from 5 to 1.5 diameters has no effect on their over-all discharge coefficient. In fact, the data agree well with those for the single hole throughout the flow range.

Holes side by side. - A reduction in the transverse spacing of 0.125-inch-diameter holes from 4 to 2 diameters (center-to-center) is shown in figure 22(b) to have no significant effect on the corrected discharge coefficient except at high (above 100) values of the flow parameter.

Significance of Results

The data presented show the variation in discharge coefficient with a flow parameter for various configurations of liner wall openings. An important difference in flow characteristic is indicated between the flush hole and the scoop or step louver. With the flush hole, the flow ceases as the flow parameter decreases to a value of 1.0 (i.e., as the static-pressure difference across the opening approaches zero); but, with the scoop and the step louver, flow continues (because of ram pressure) to some lower value of the flow parameter (depending on the height of the scoop). Combustor designs having low over-all total-pressure loss and a high air velocity in the passage outside the liner tend to have a low or even a negative static-pressure difference across the upstream liner wall openings (ref. 2). The high discharge coefficient of scoops or louvers at flow parameters less than 1.0 makes them essential for adequate air admission in the upstream region of such liners.

Application of Data

The results of references 3 and 4 indicate that discharge coefficients for holes having external flow only should be applicable to combined internal and external flow, if the jet velocity is greater than the internal parallel flow velocity and the correct jet outlet static pressure is used. Discharge coefficients for various liner wall openings may be determined from the corrected discharge coefficients in figures 14 to 22 in this report or from applicable figures in reference 1 by the following method:

(1) At a given value of the flow parameter $(P_d - p_j)/(P_d - p_d)$ a corrected discharge coefficient C_p (or C_{p,δ^*}) can be read from a curve (figs. 14 to 22) selected on the basis of geometric similarity (both as to shape and size) to the given liner wall opening.

(2) The corrected discharge coefficient C_{p,δ^*} for step louvers and scoops (figs. 15 to 18 and 20) must first be reduced to C_p by

$$C_p = C_{p,\delta^*} \frac{A_f^*}{A_f} = C_{p,\delta^*} \left(1 - \frac{b\delta^*}{A_f} \right)$$

where δ^* , the boundary-layer displacement thickness, may be estimated from figure 9 for the local flow condition. The lower limit of the flow range for step louvers and scoops may be estimated from the curve of figure 12.

(3) A pressure-ratio correction factor C/C_p can be obtained from figure 5 at the given value of the pressure ratio $(p_d + q_d \sin \theta)/p_j$.

(4) The product of $(C/C_p)C_p$ then yields the desired discharge coefficient C .

SUMMARY OF RESULTS

The following results were obtained from an evaluation of the effects of various geometric and flow factors on discharge coefficients for flush rectangular holes, step louvers, and scoops:

1. For each configuration the discharge coefficients, corrected for pressure-ratio and boundary-layer effects, where applicable, were correlated with a dimensionless flow parameter.

2. The effects of size or shape of flush rectangular holes on discharge coefficient were small compared with the effects of duct stream velocity and static-pressure ratio across the hole.

4705

3. The addition of a scoop to a flush hole increased the discharge coefficient and extended the flow range at low values of the flow parameter but decreased the discharge coefficient at high values for scoop face areas less than 1.4 times the hole area.

4. Step louvers and scoops had greater discharge coefficients and wider flow ranges at low values of the flow parameter than the flush holes. However, the discharge coefficient in this region was affected by boundary-layer conditions of the duct stream, whereas the extent of the flow range appeared to be a function of scoop height. The high discharge coefficients for louvers and scoops at low values of the flow parameter make them essential for adequate air admission in the upstream region of combustor liners having a low static-pressure difference across their openings.

5. For flush holes and step louvers mounted in walls of a convergent duct wall, inclinations of up to 20° had little effect on discharge coefficient.

6. The proximity of the multiple flush holes in the range from 5 to 1.5 diameters (center-to-center) in a longitudinal direction or 4 to 2 diameters in a transverse direction had no significant effect on discharge coefficient.

Lewis Flight Propulsion Laboratory
National Advisory Committee for Aeronautics
Cleveland, Ohio, December 6, 1957

REFERENCES

1. Dittrich, Ralph T., and Graves, Charles C.: Discharge Coefficients for Combustor-Liner Air-Entry Holes. I - Circular Holes with Parallel Flow. NACA TN 3663, 1956.
2. Grobman, J. S., Dittrich, R. T., and Graves, C. C.: Pressure Drop and Air Flow Distribution in Gas Turbine Combustors. Trans. ASME, vol. 79, no. 7, Oct. 1957, pp. 1601-1607.
3. Callaghan, Edmund E., and Bowden, Dean T.: Investigation of Flow Coefficient of Circular, Square, and Elliptical Orifices at High-Pressure Ratios. NACA TN 1947, 1949.
4. Dewey, Paul E.: A Preliminary Investigation of Aerodynamic Characteristics of Small Inclined Air Outlets at Transonic Mach Numbers. NACA TN 3442, 1955. (Supersedes NACA RM L53C10.)

TABLE I. - DETAILS OF AIR-ENTRY CONFIGURATIONS INVESTIGATED
 (All dimensions in inches.)
 (a) Flush rectangular holes A-1 to A-5

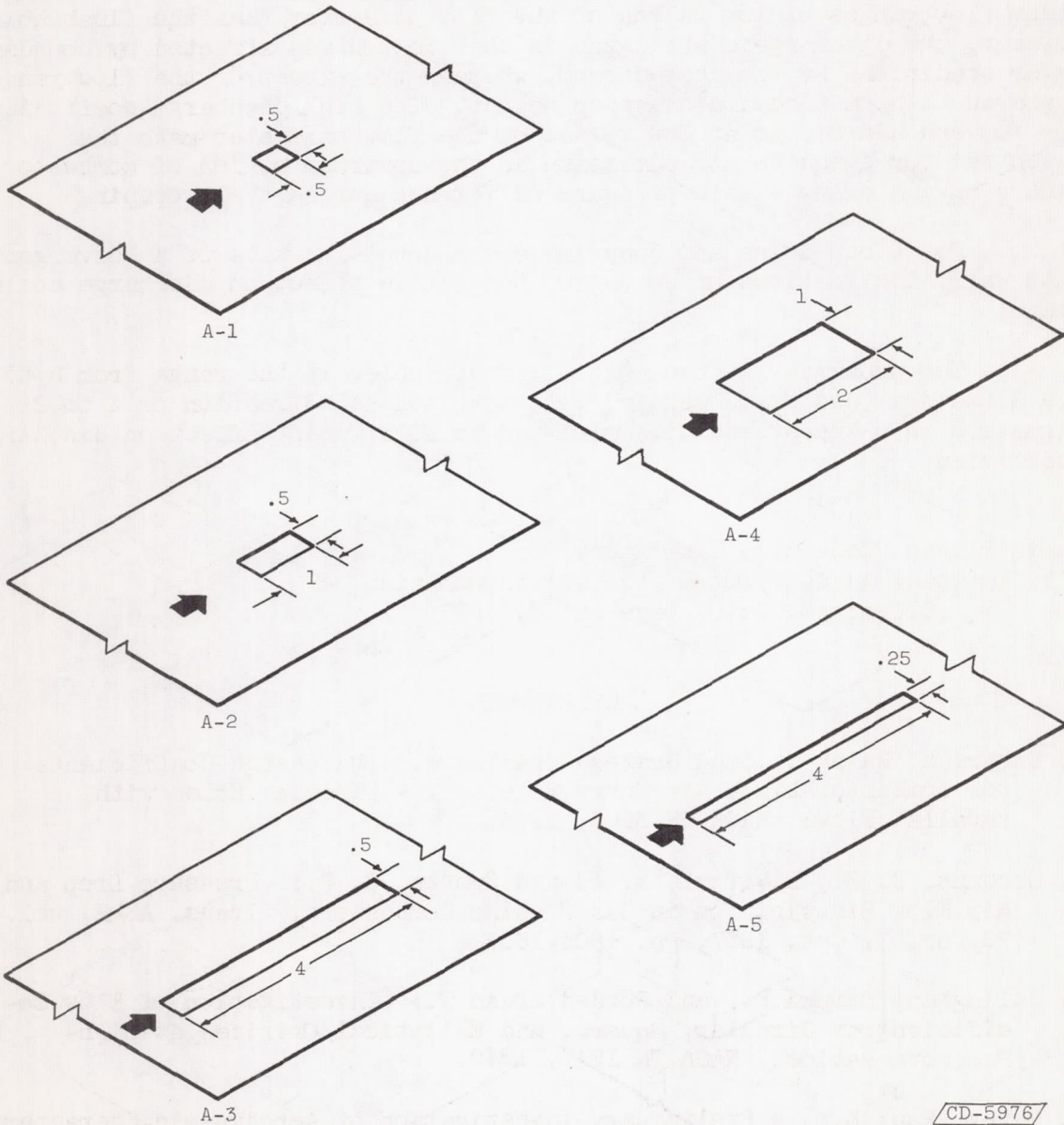

CD-5976

4705

TABLE I. - CONTINUED. DETAILS OF AIR-ENTRY CONFIGURATIONS INVESTIGATED
 (All dimensions in inches.)
 (b) Step louvers B-1 to B-6

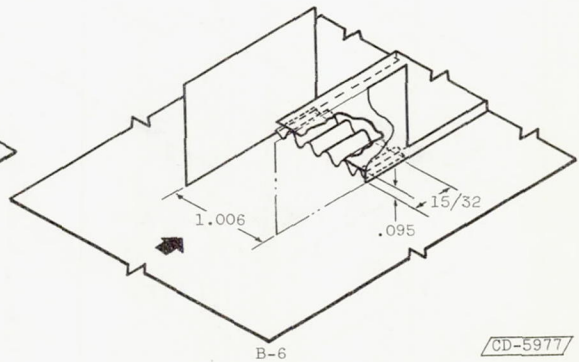
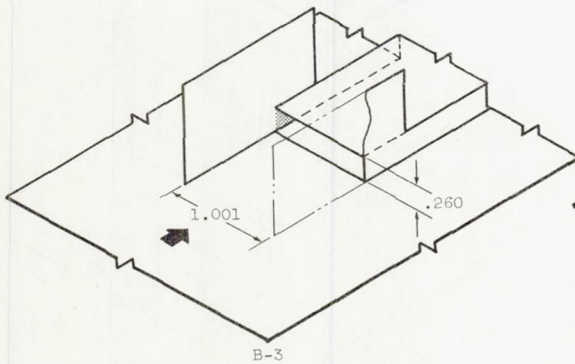
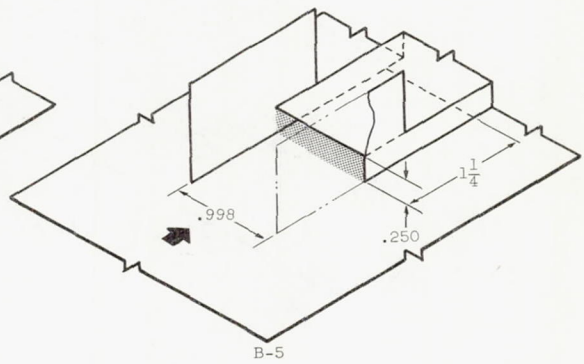
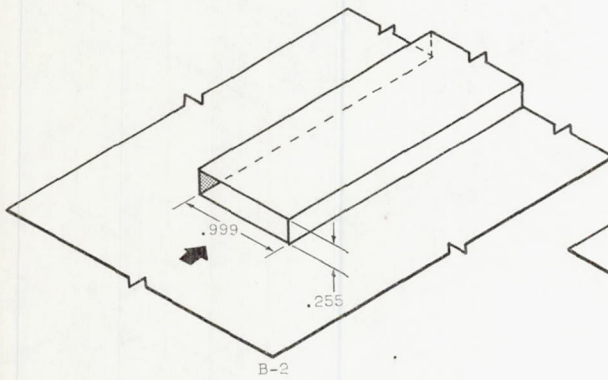
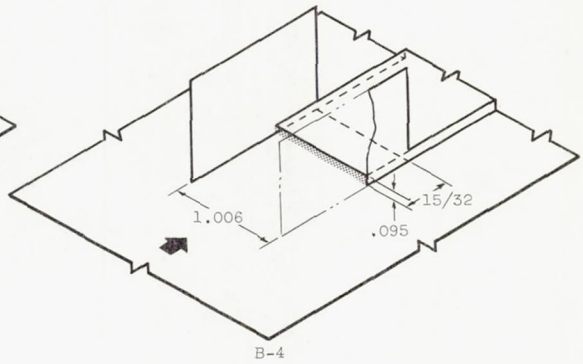
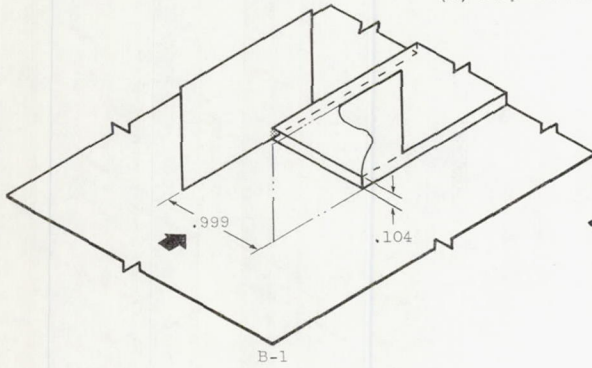

CD-5977

4705

TABLE I. - CONTINUED. DETAILS OF AIR-ENTRY CONFIGURATIONS INVESTIGATED
(All dimensions in inches.)
(c) Step louvers B-7 to B-12

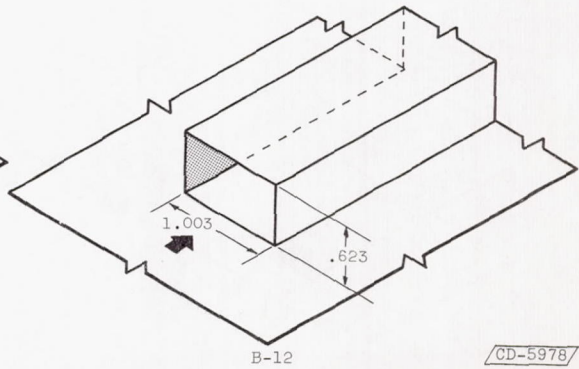
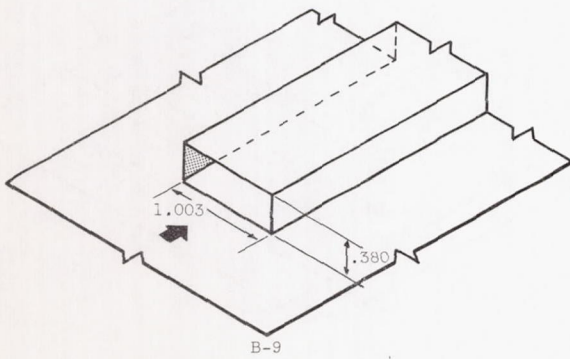
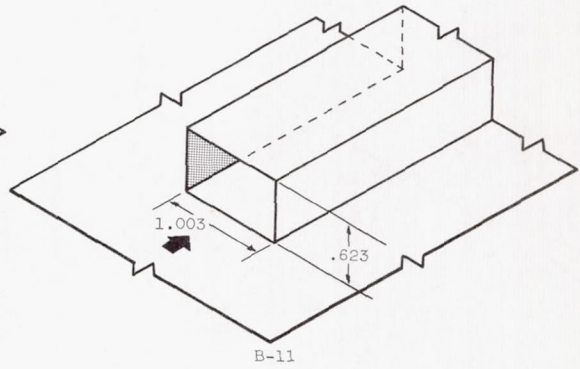
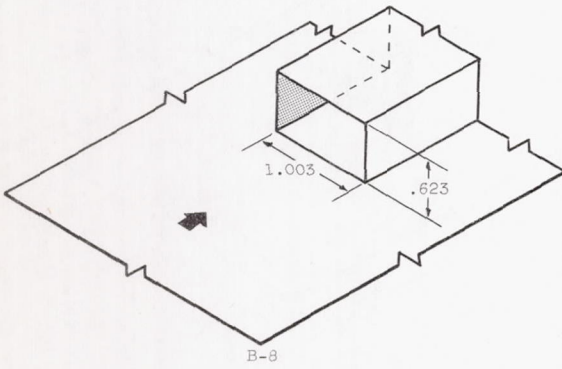
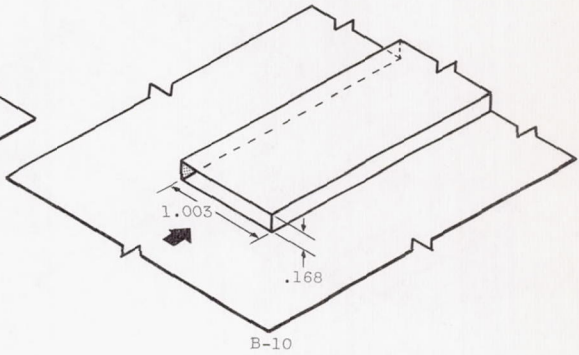
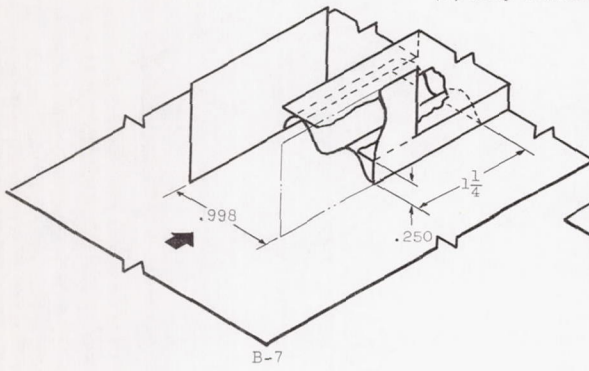

4705

CJ-3

TABLE I. - CONTINUED. DETAILS OF AIR-ENTRY CONFIGURATIONS INVESTIGATED
(All dimensions in inches.)

(d) Thumbnail-type louvers C-1 and C-2 and scoops over circular holes D-1 to D-4

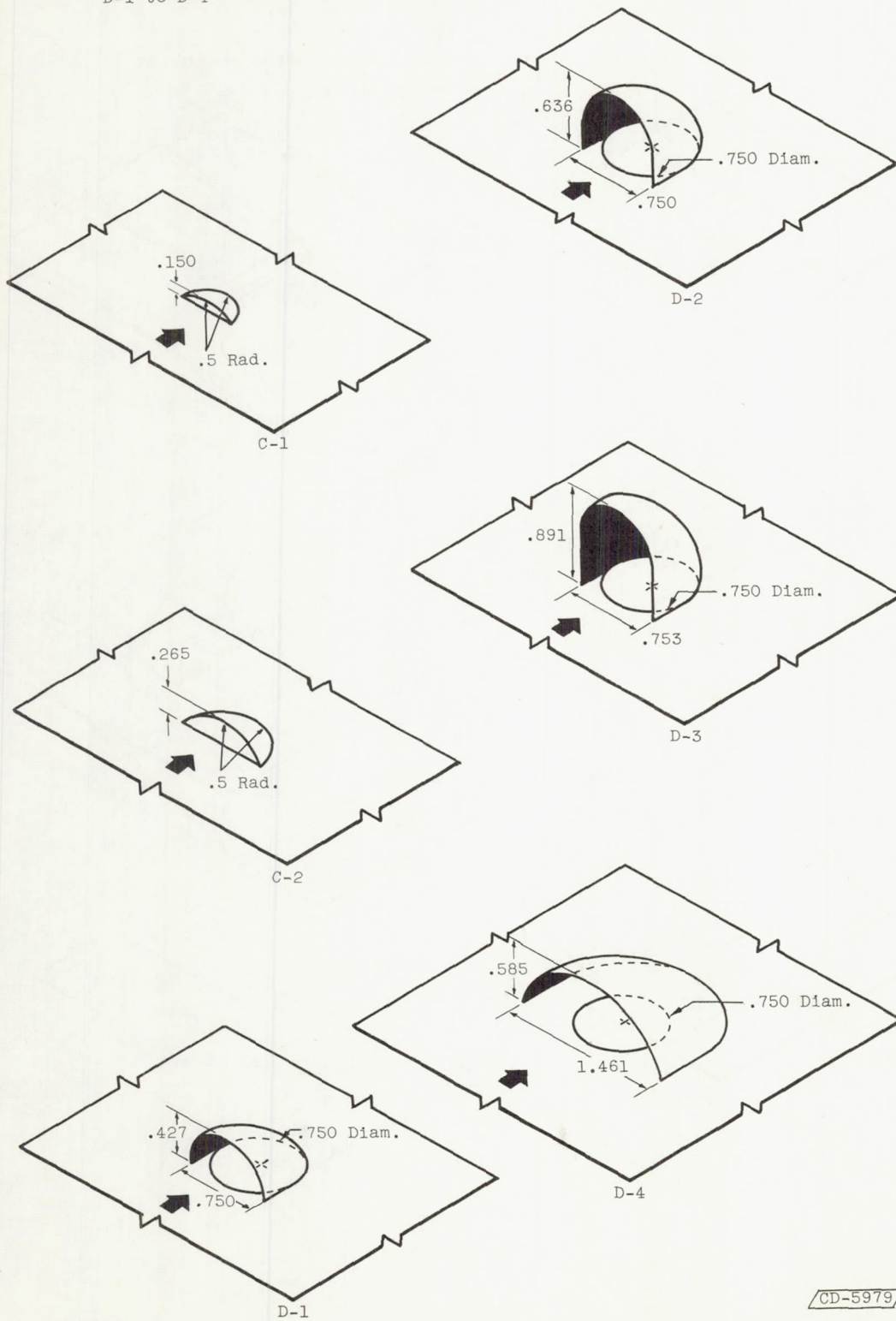

4705

TABLE I. - CONTINUED. DETAILS OF AIR-ENTRY CONFIGURATIONS INVESTIGATED
(All dimensions in inches.)
(e) Hole or louver in inclined wall E-1 to E-5

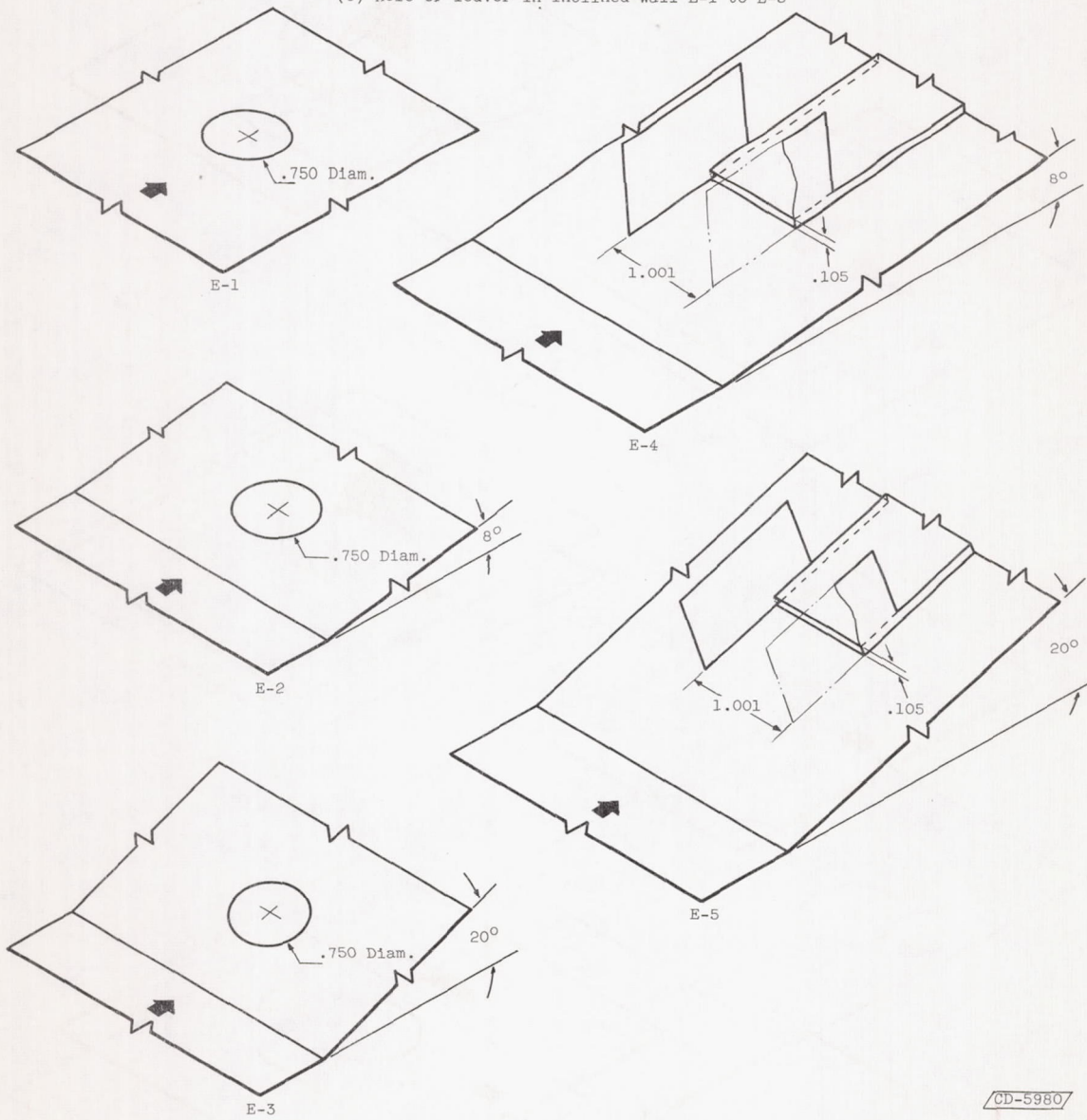

CD-5980

4705

CJ-3 back

TABLE I. - CONCLUDED. DETAILS OF AIR-ENTRY CONFIGURATIONS INVESTIGATED
(All dimensions in inches.)
(f) Multiple circular holes F-1 to F-4

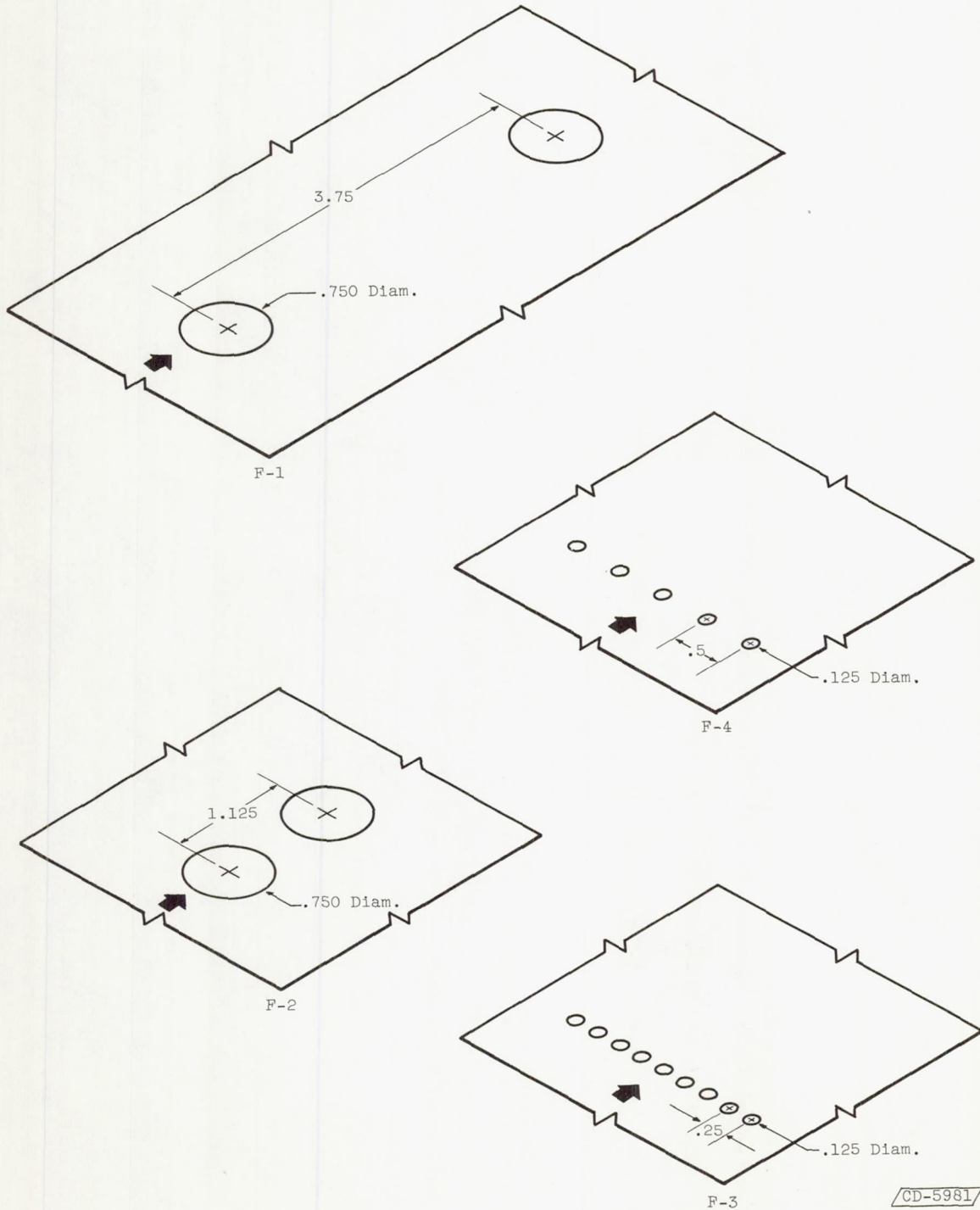

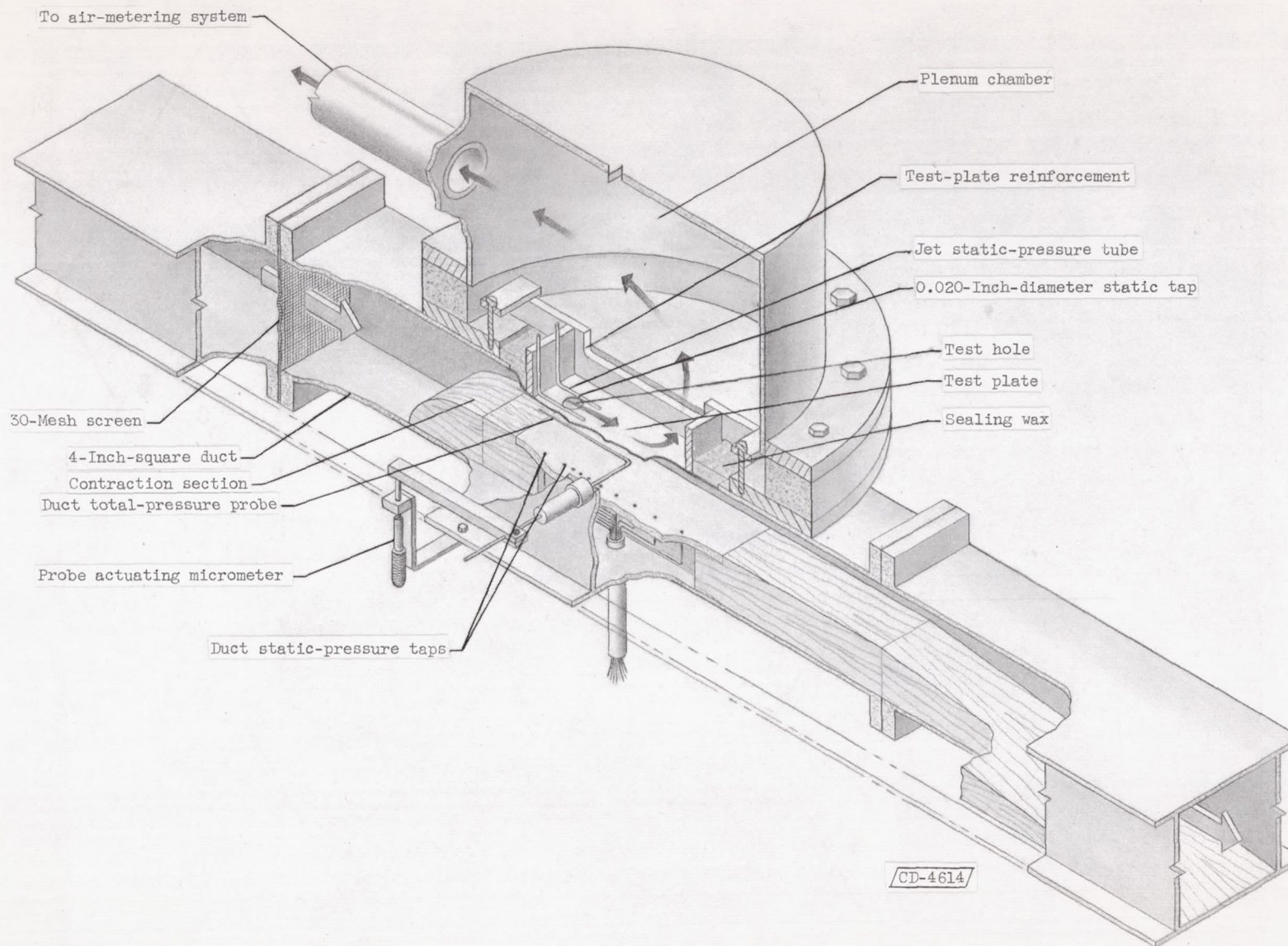

(a) Test plate flush with duct wall.

Figure 1. - Details of test apparatus for study of discharge coefficients.

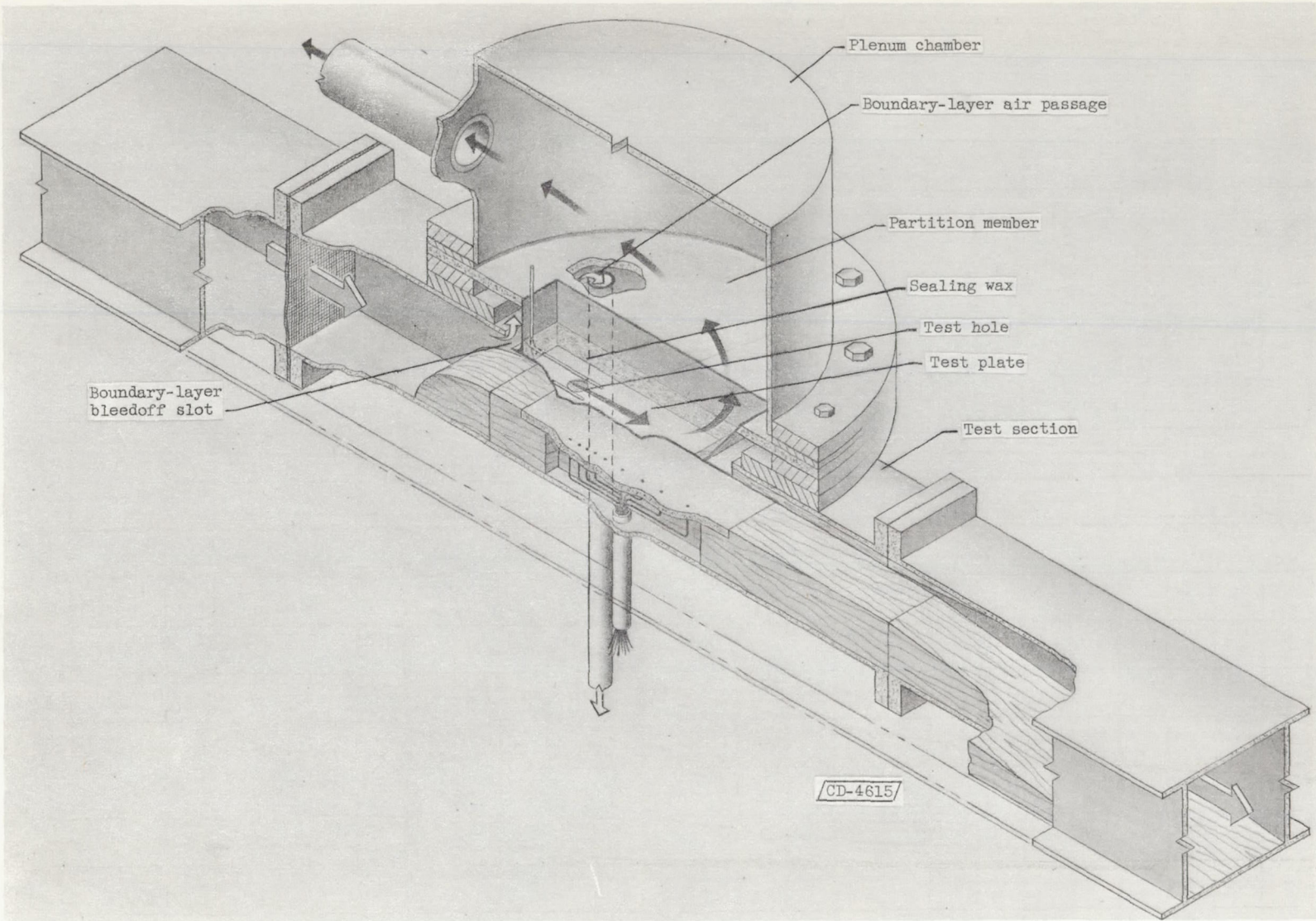

(b) Modified for boundary-layer bleedoff.

Figure 1. - Concluded. Details of test apparatus for study of discharge coefficients.

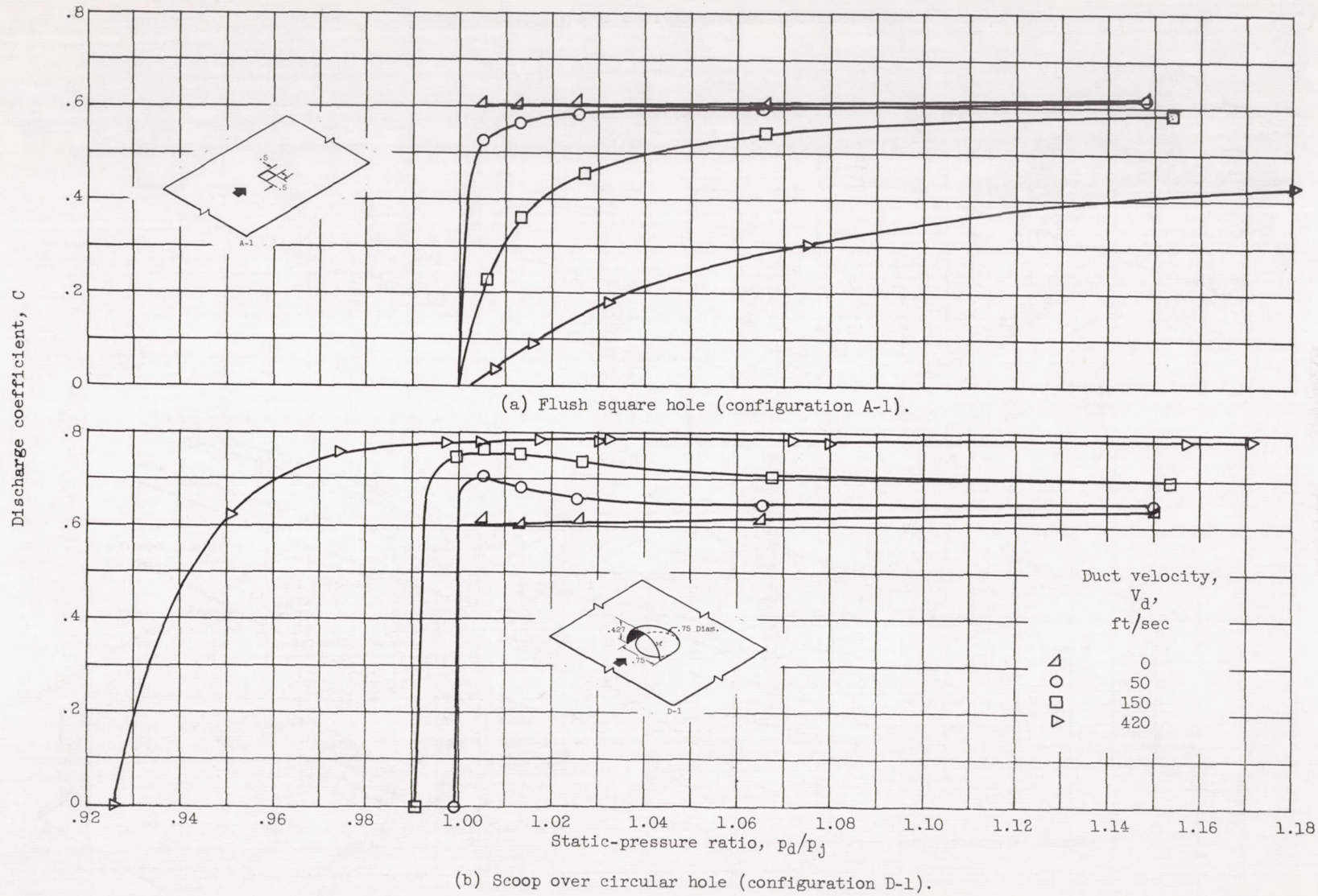

Figure 2. - Effect of static-pressure ratio on discharge coefficient at various duct velocities.

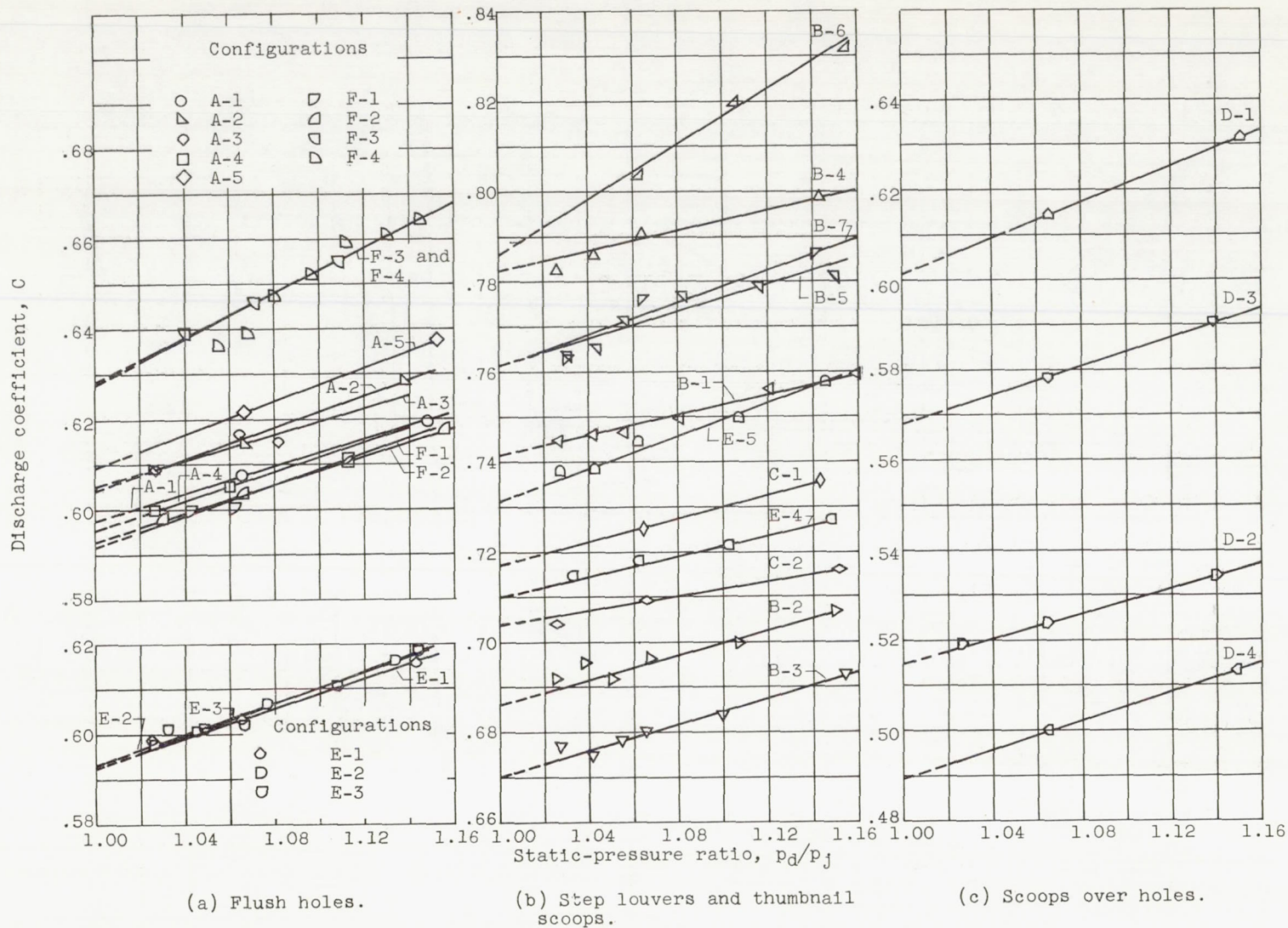

Figure 3. - Variation in discharge coefficients of 27 configurations with pressure ratio at zero duct velocity.

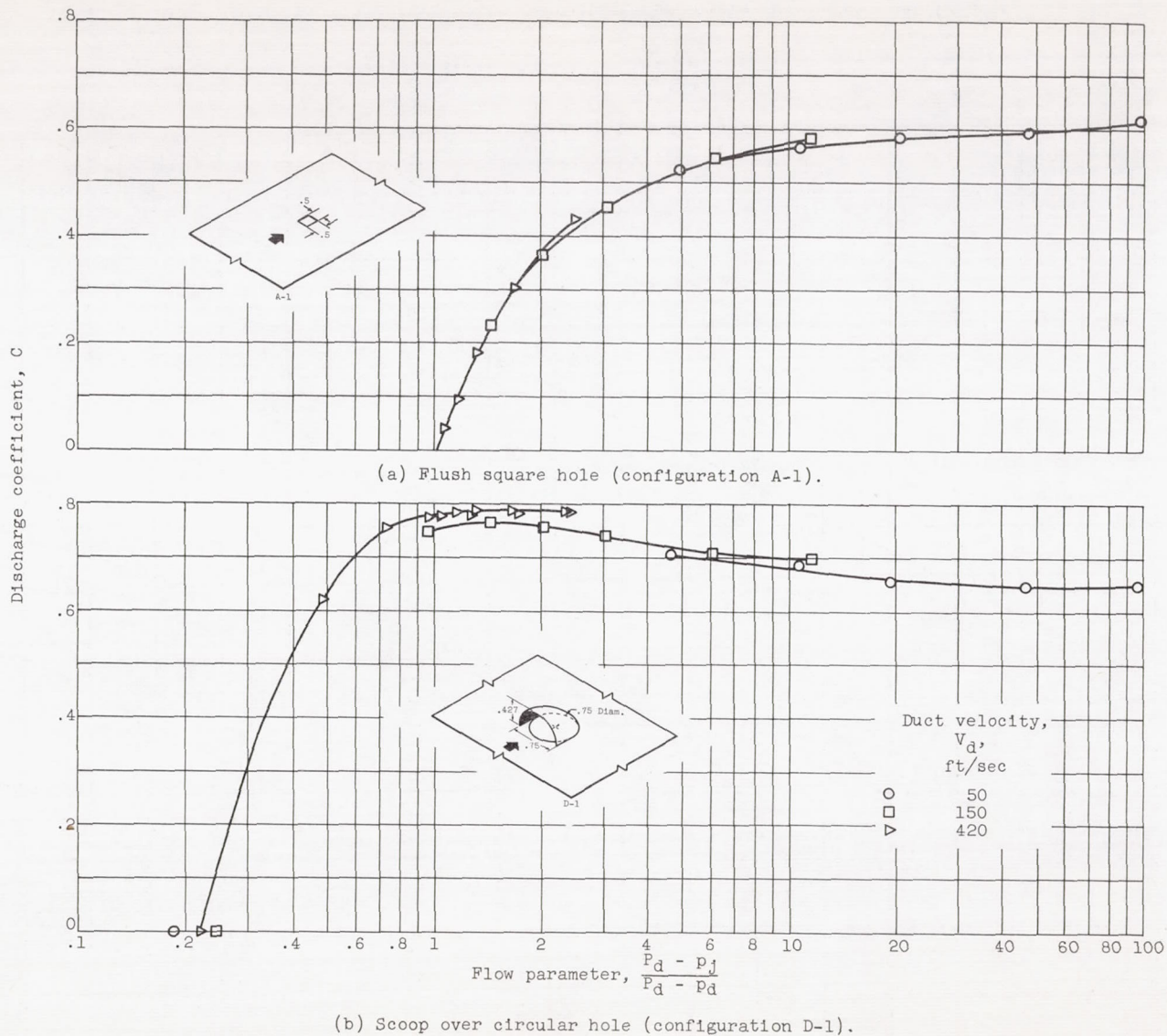

Figure 4. - Variation in discharge coefficient with flow parameter at various duct velocities.

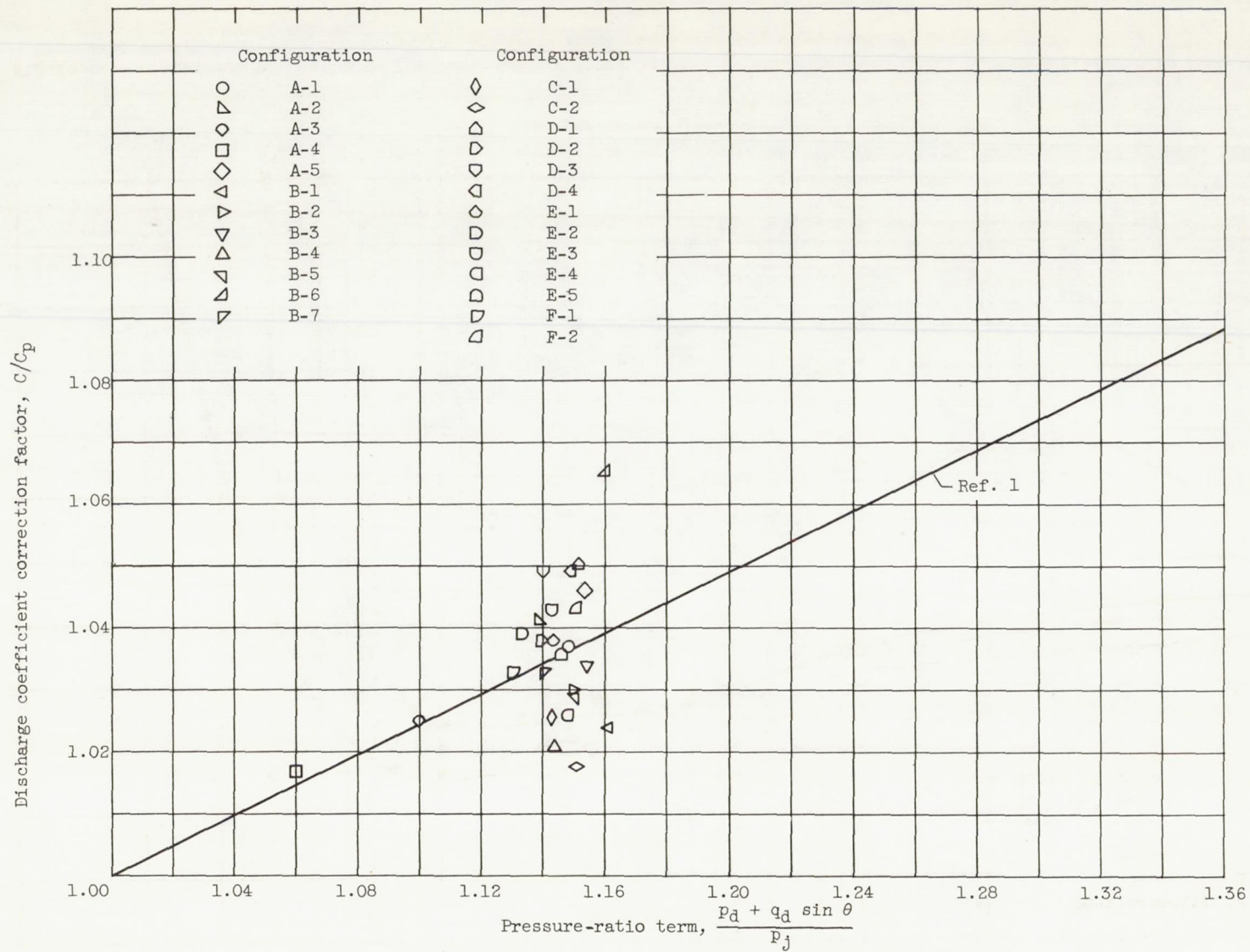

Figure 5. - Pressure-ratio correction factor for discharge coefficients.

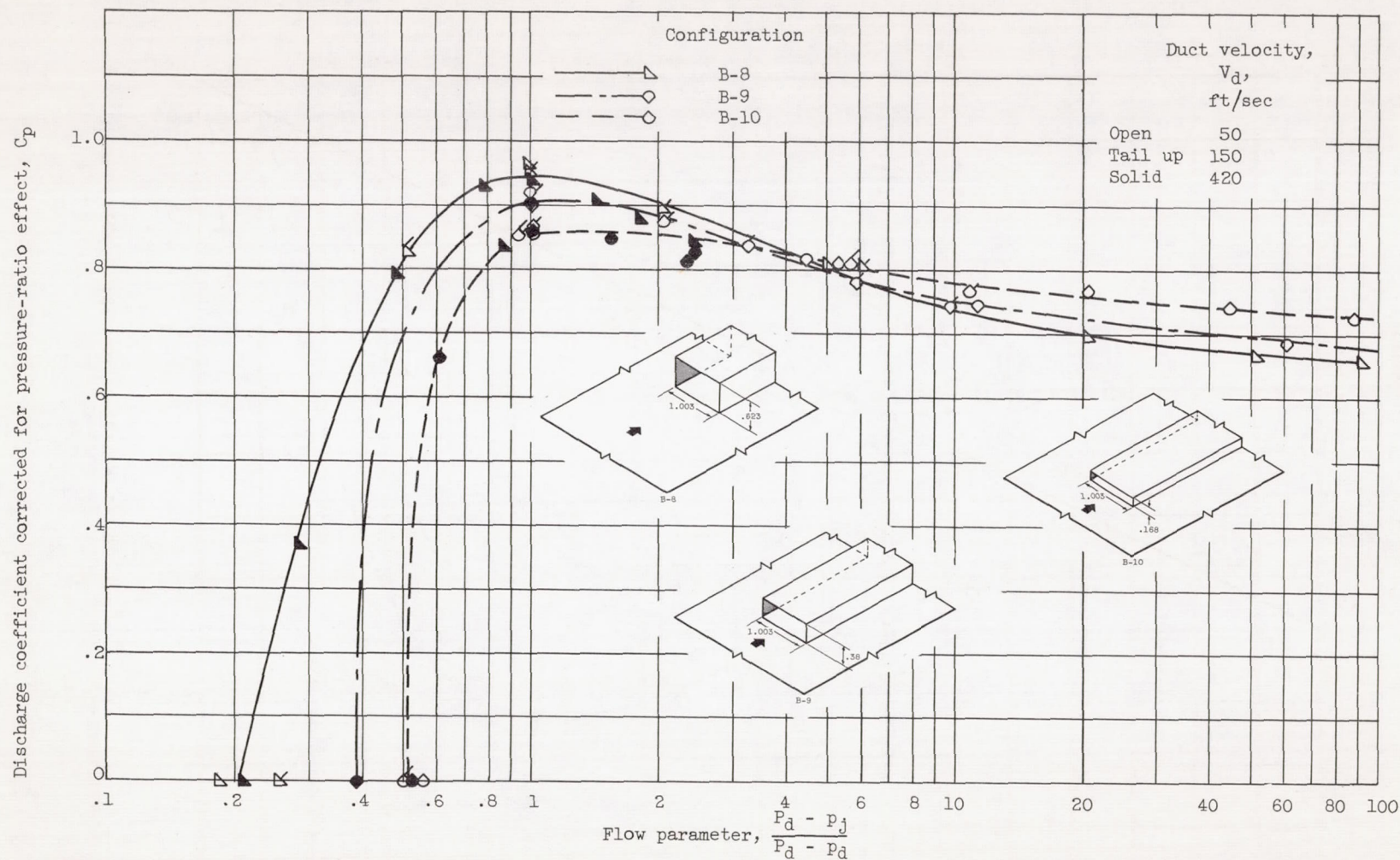

Figure 6. - Comparison of discharge coefficients for three heights of step louvers. Duct boundary layer, 0.10 inch thick. Discharge coefficients not corrected for boundary-layer effects.

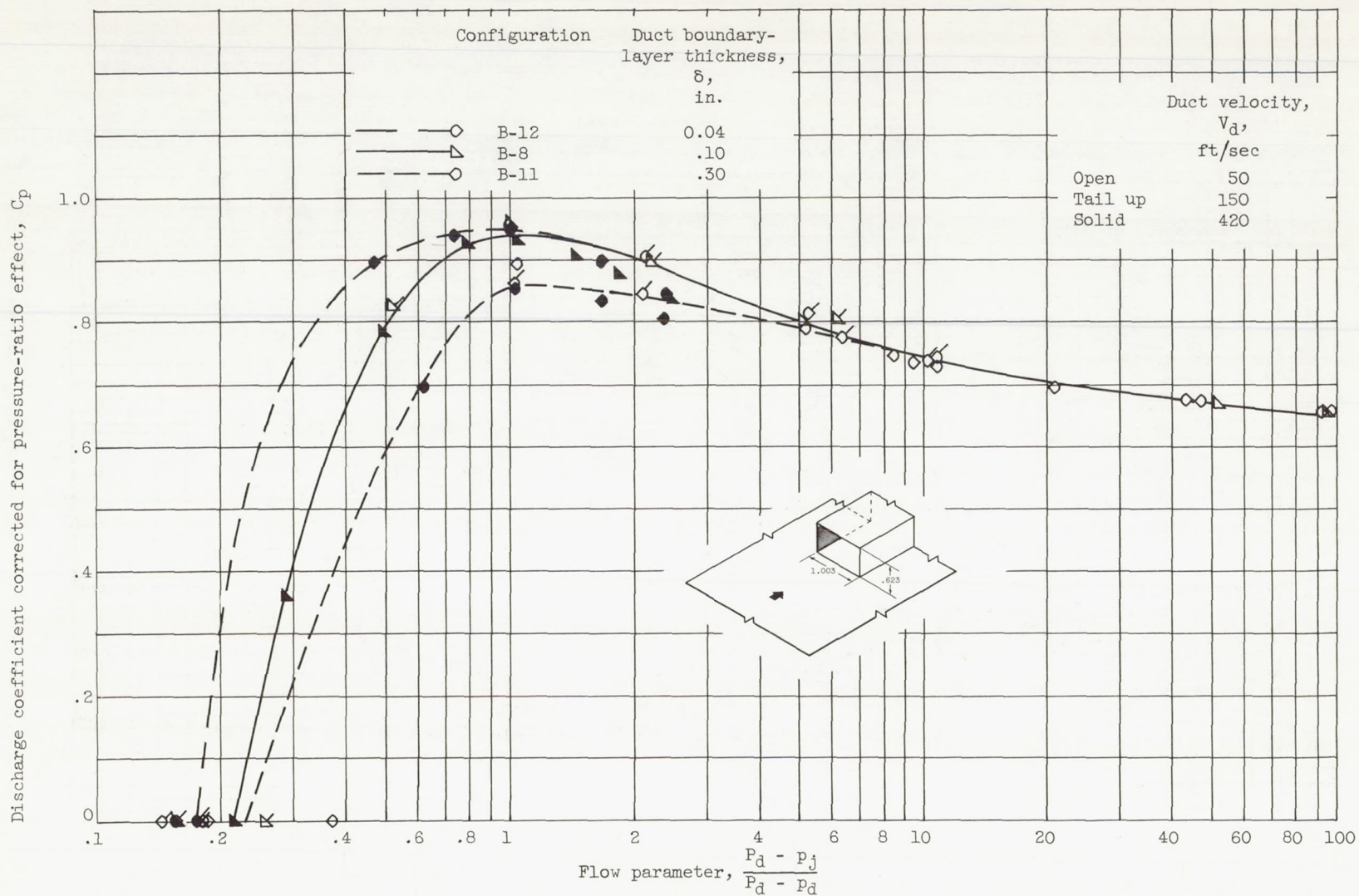
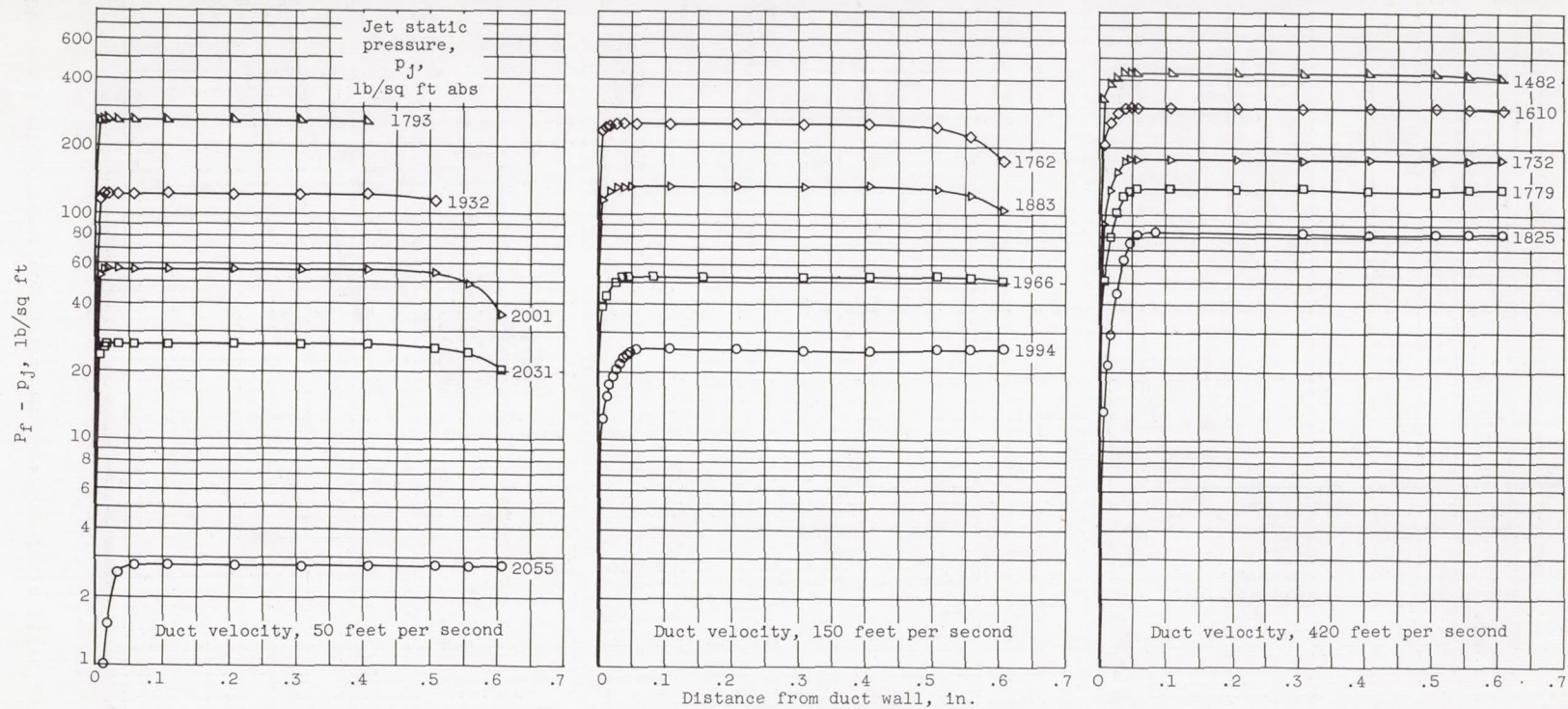
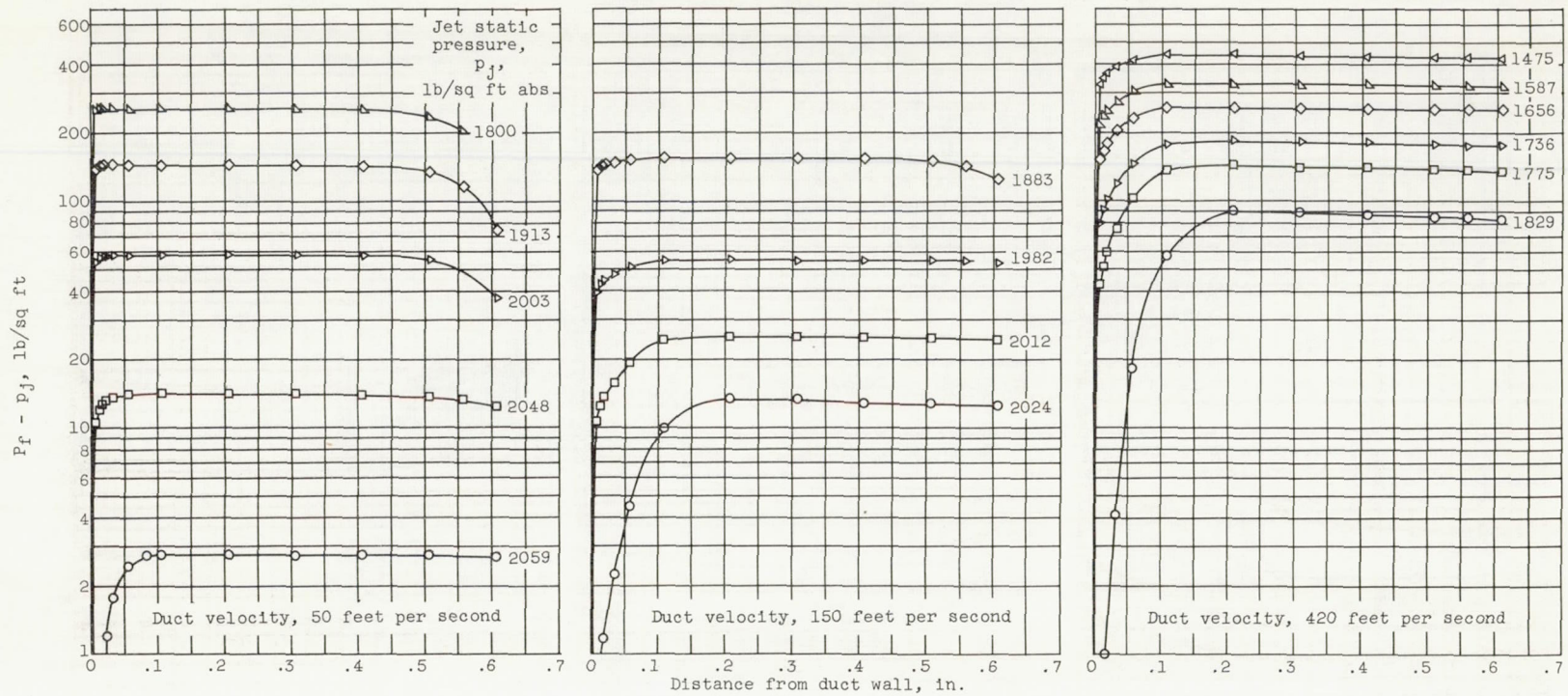

Figure 7. - Comparison of discharge coefficients for three values of duct boundary-layer thickness. Step louver, 0.623 inch high. Discharge coefficients not corrected for boundary-layer effects.



(a) Duct boundary layer, 0.04 inch thick.

Figure 8. - Pressure profiles measured at face of 0.623-inch-high step louver at various flow conditions.



(b) Duct boundary layer, 0.10 inch thick.

Figure 8. - Continued. Pressure profiles measured at face of 0.623-inch-high step louver at various flow conditions.

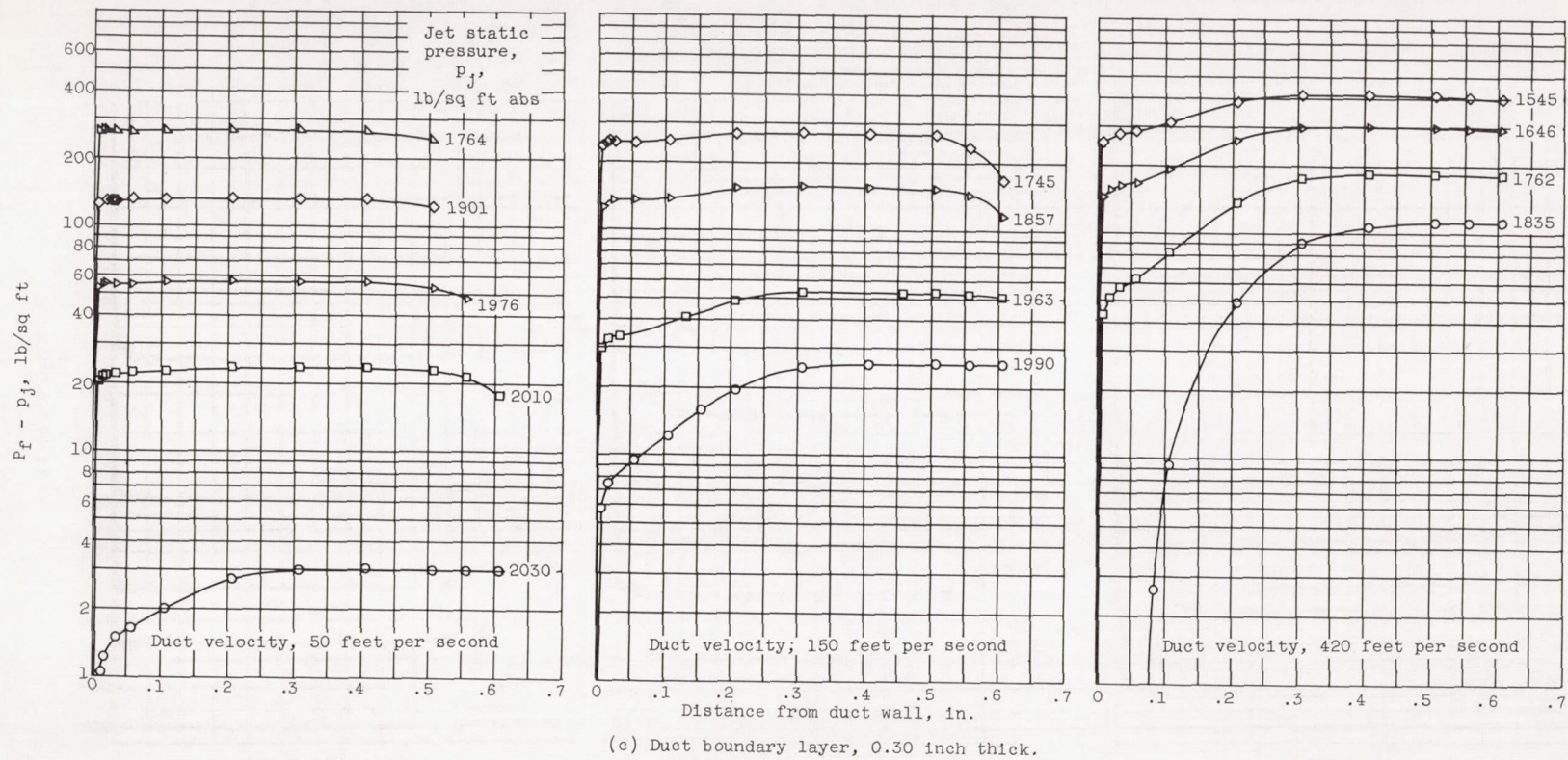

Figure 8. - Concluded. Pressure profiles measured at face of 0.623-inch-high step louver at various flow conditions.

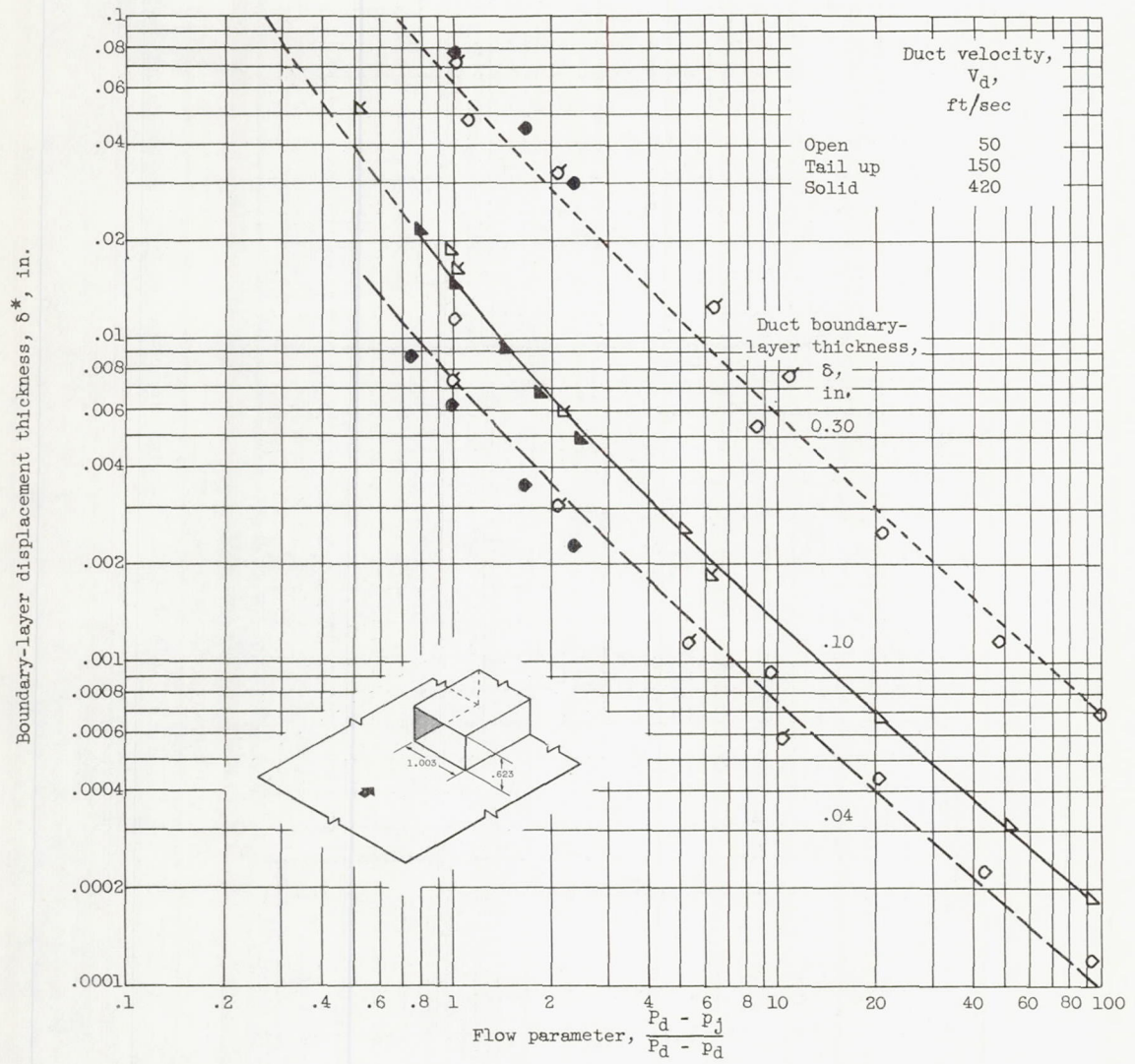

Figure 9. - Variation in boundary-layer displacement thickness at face of louver with flow parameter for three duct boundary-layer conditions.

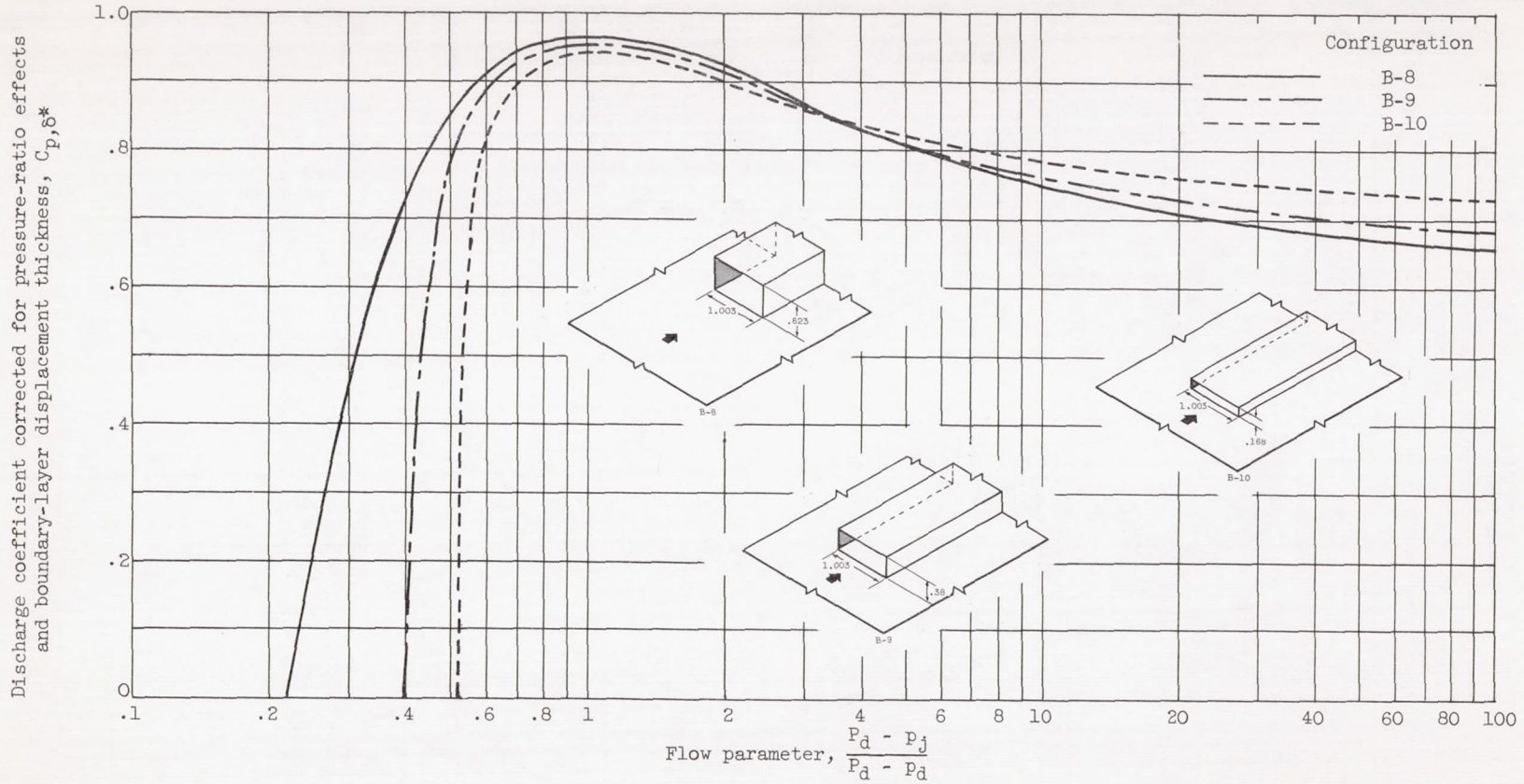

Figure 10. - Comparison of discharge coefficients for three heights of step louvers. Discharge coefficients corrected for pressure-ratio effects and boundary-layer displacement thickness.

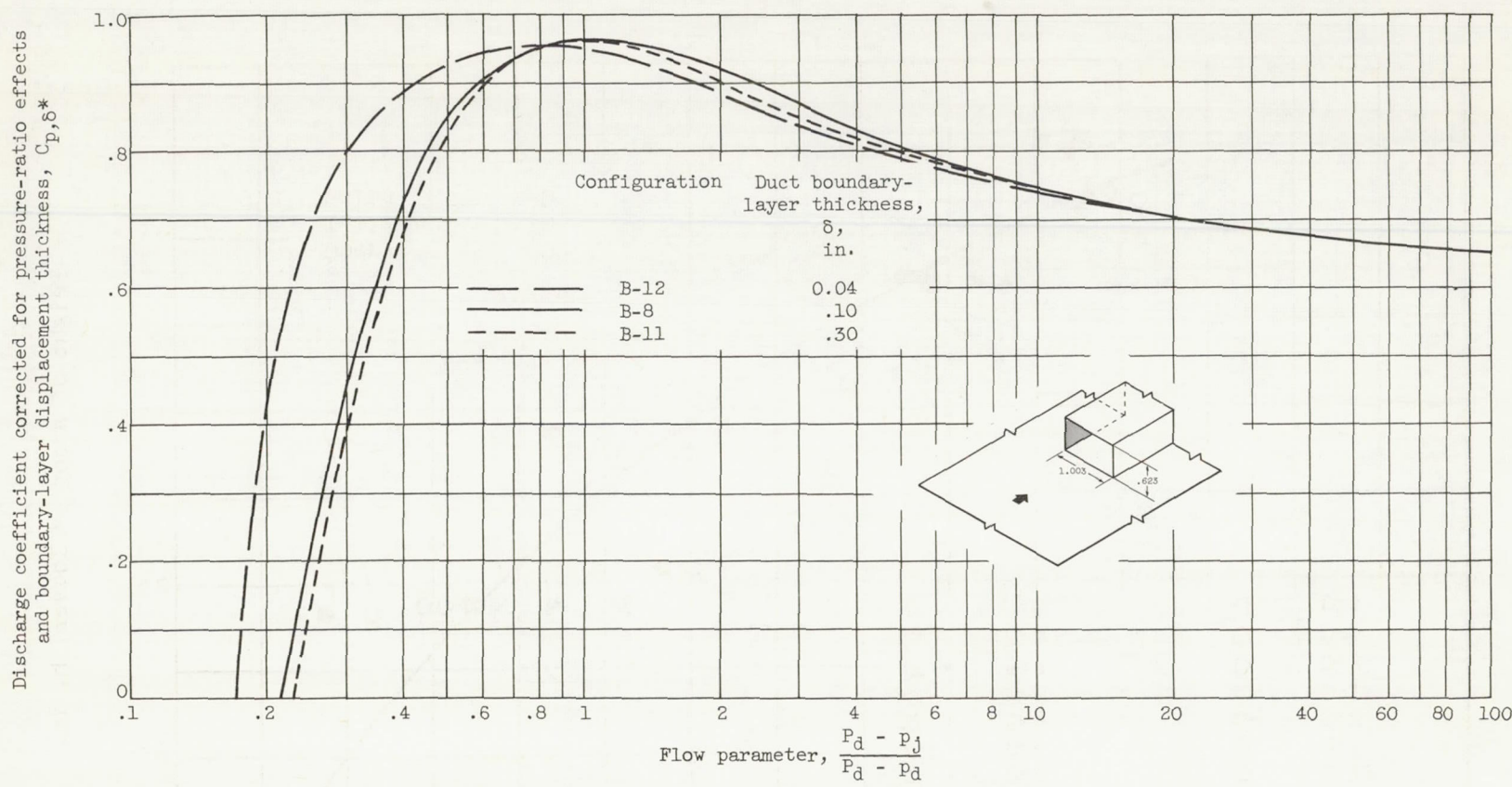

Figure 11. - Comparison of discharge coefficients for three values of duct boundary-layer thickness. Step louver, 0.623 inch high. Discharge coefficients corrected for pressure-ratio effects and boundary-layer displacement thickness.

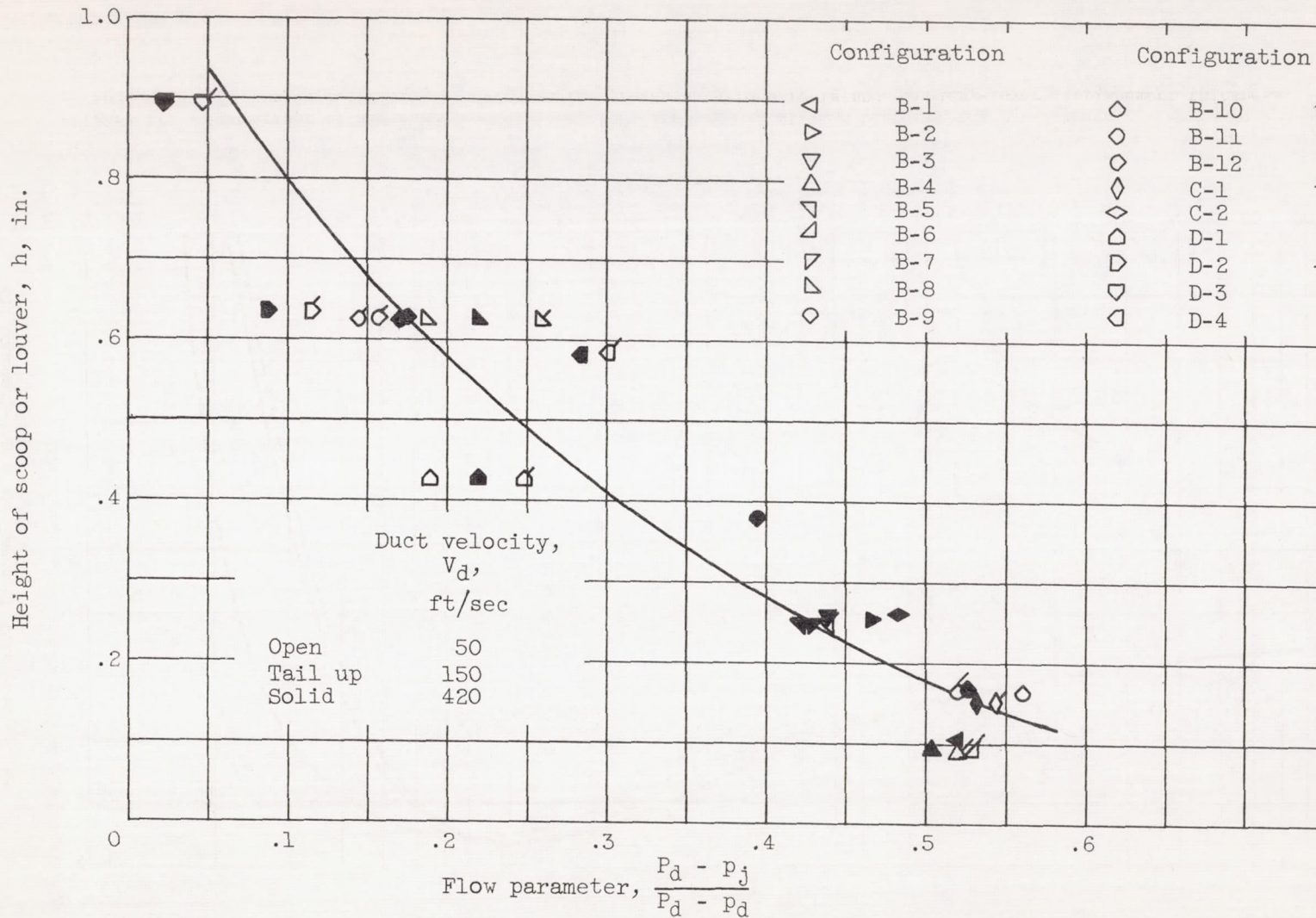
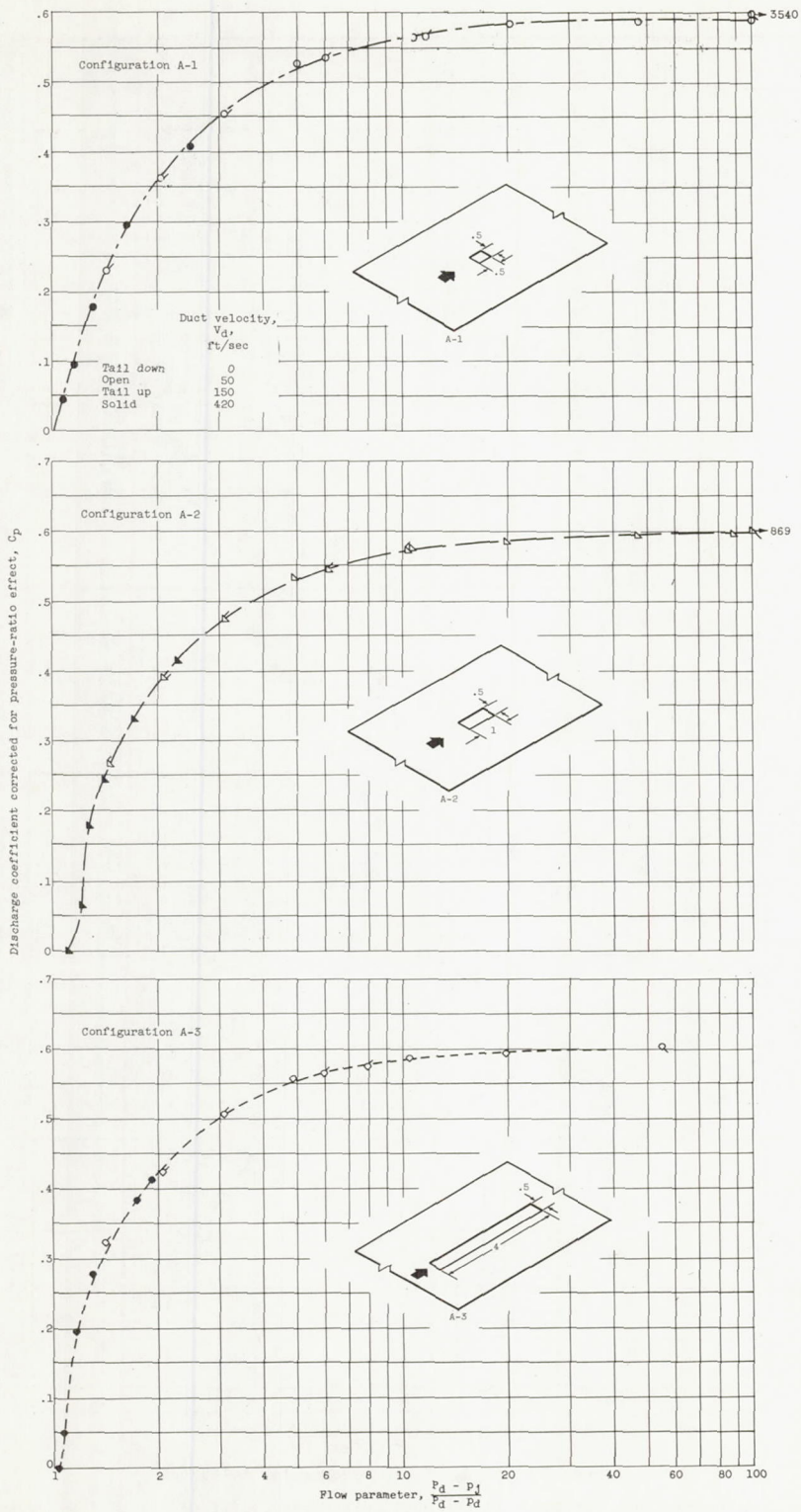
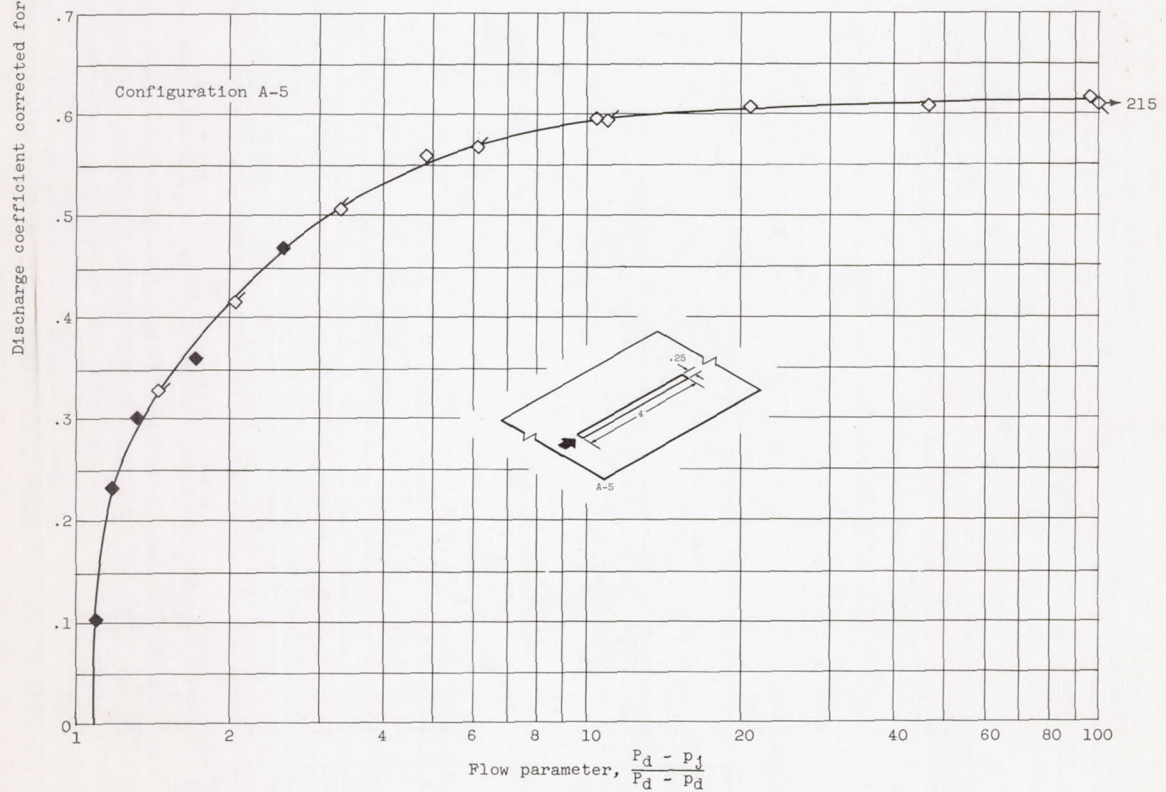
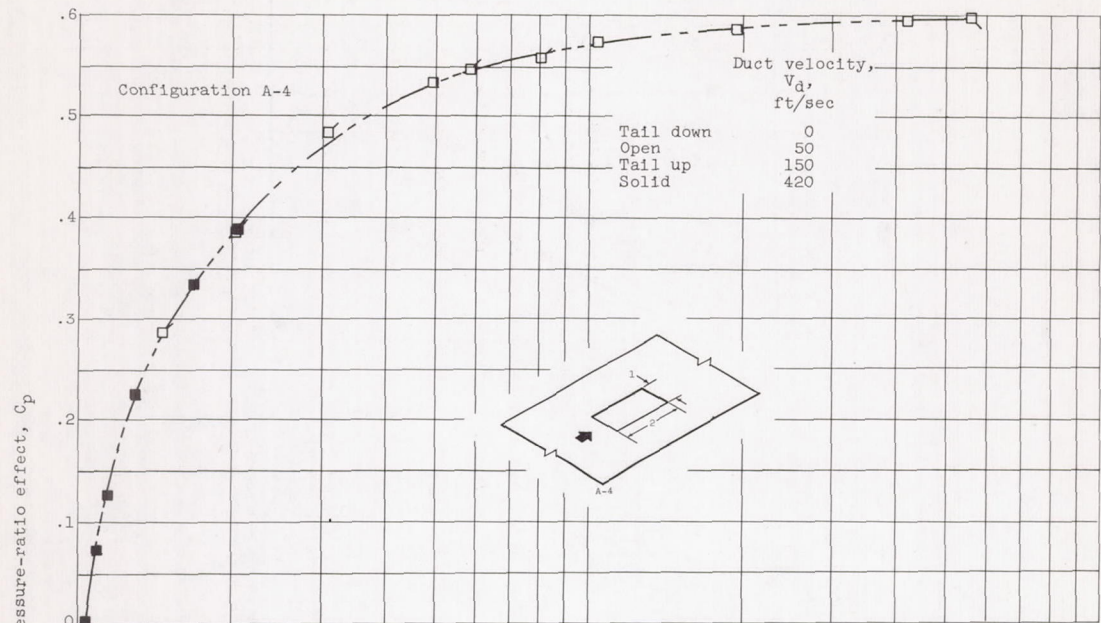

Figure 12. - Variation of flow-parameter values at zero flow through opening with scoop or louver height.



(a) Flush rectangular holes.

Figure 13. - Variation of corrected discharge coefficient with flow parameter.



(a) Concluded. Flush rectangular holes.

Figure 13. - Continued. Variation of corrected discharge coefficient with flow parameter.

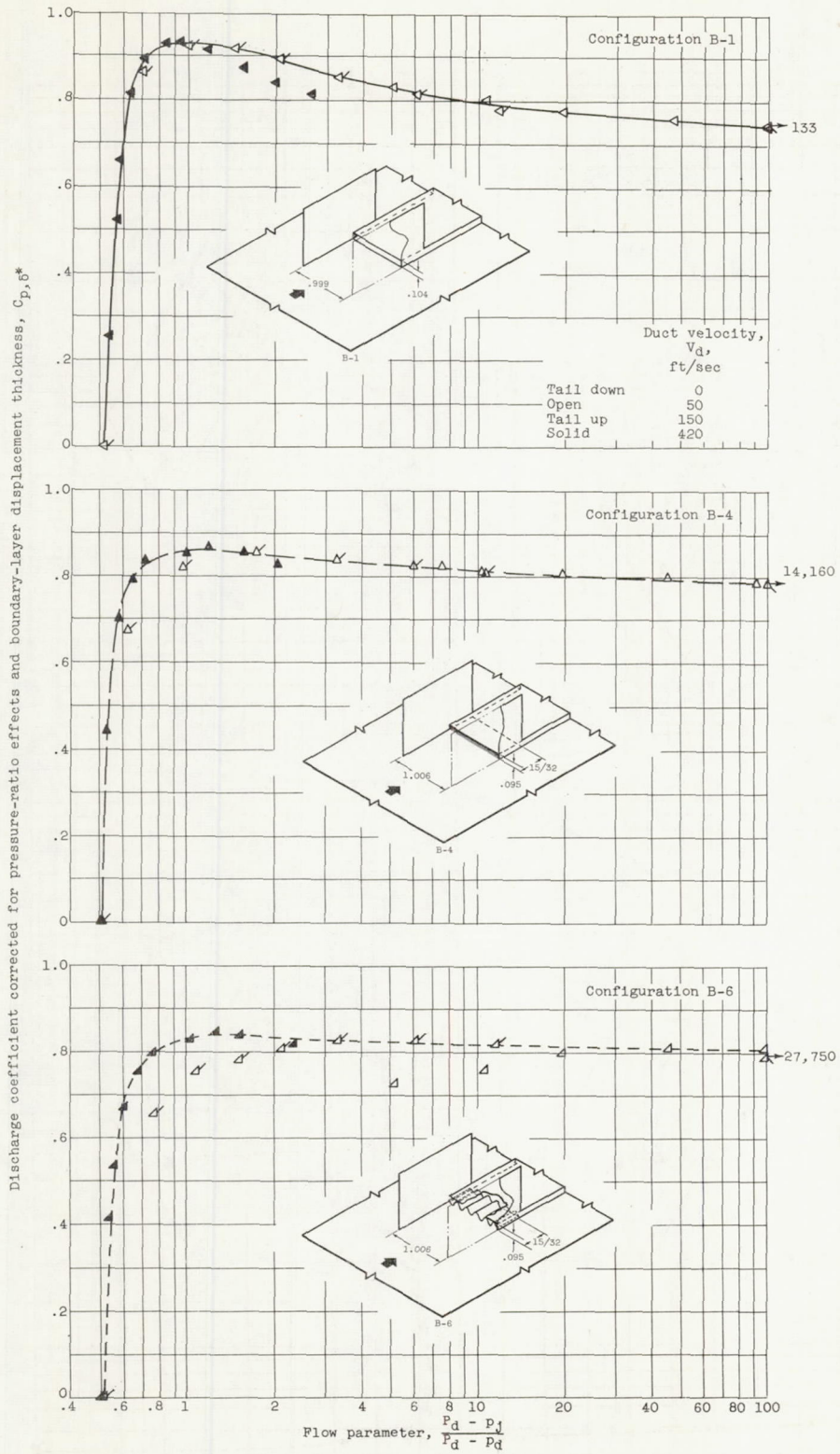

(b) Step louvers.

Figure 13. - Continued. Variation of corrected discharge coefficient with flow parameter.

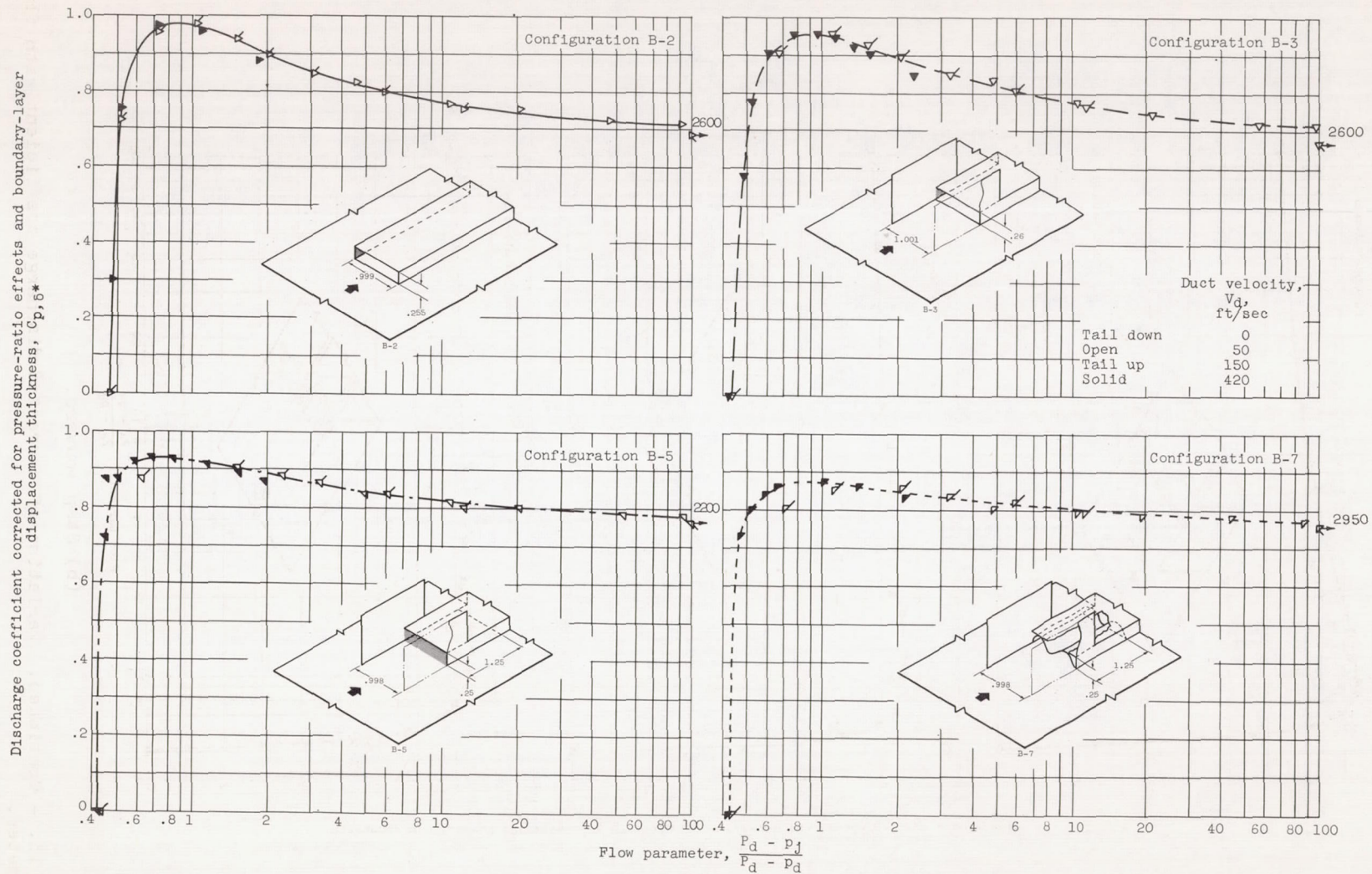

(b) Concluded. Step louvers.

Figure 13. - Continued. Variation of corrected discharge coefficient with flow parameter.

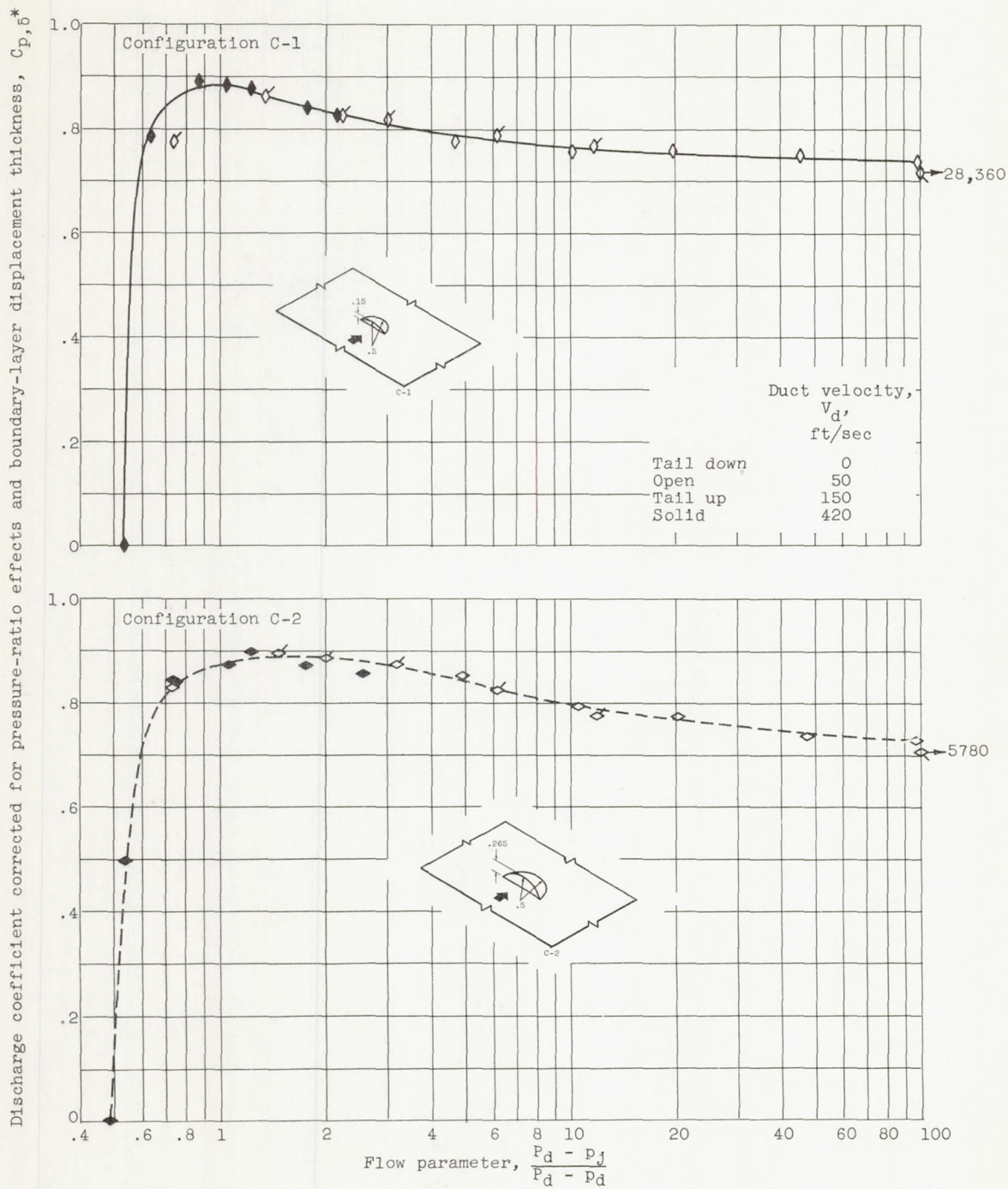

(c) Thumbnail-type scoops.

Figure 13. - Continued. Variation of corrected discharge coefficient with flow parameter.

4705

Discharge coefficient corrected for pressure-ratio effect, C_p , or for pressure-ratio effects and boundary-layer displacement thickness, C_{p,δ^*}

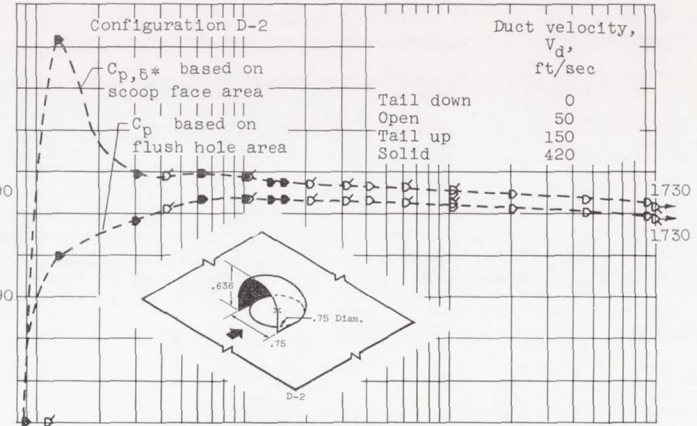
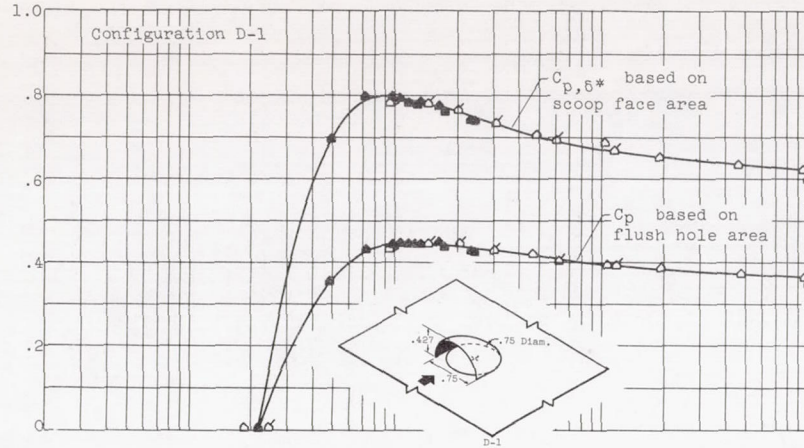

Discharge coefficient corrected for pressure-ratio effect, C_p

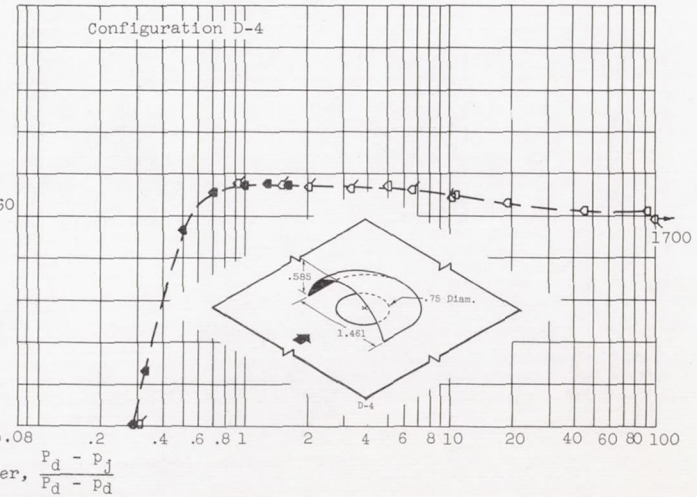
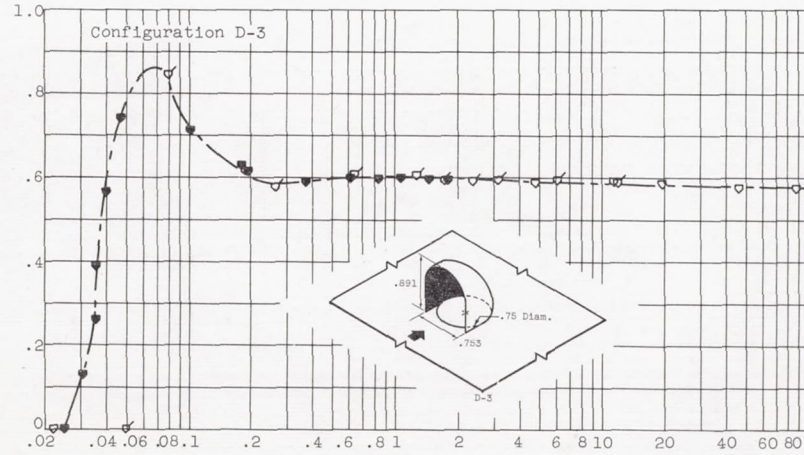

(d) Scoops over circular holes.

Figure 13. - Continued. Variation of corrected discharge coefficient with flow parameter.

4705

CU-6 back

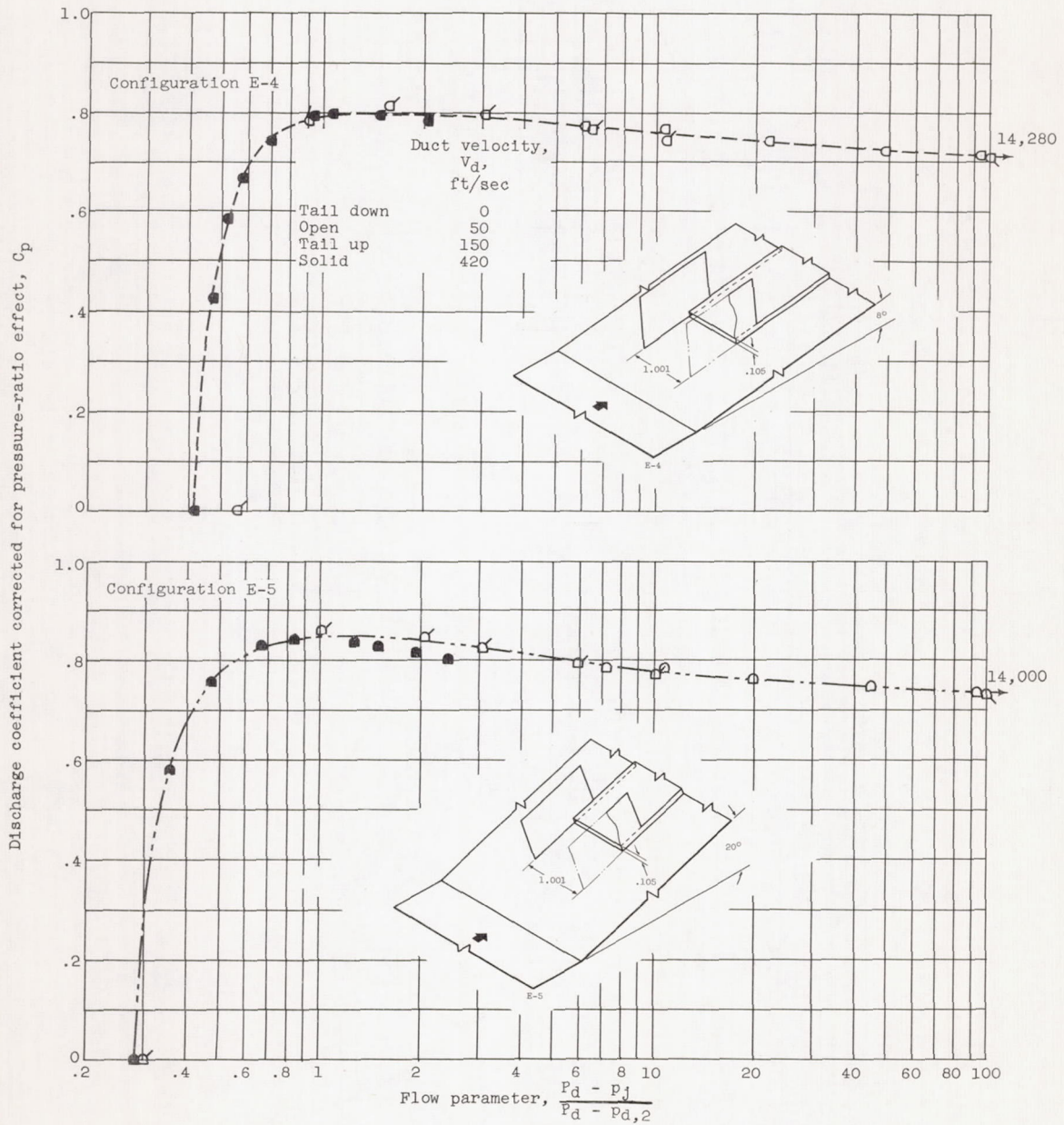

(e) Concluded. Flush hole or step louver on inclined wall.

Figure 13. - Continued. Variation of corrected discharge coefficient with flow parameter.

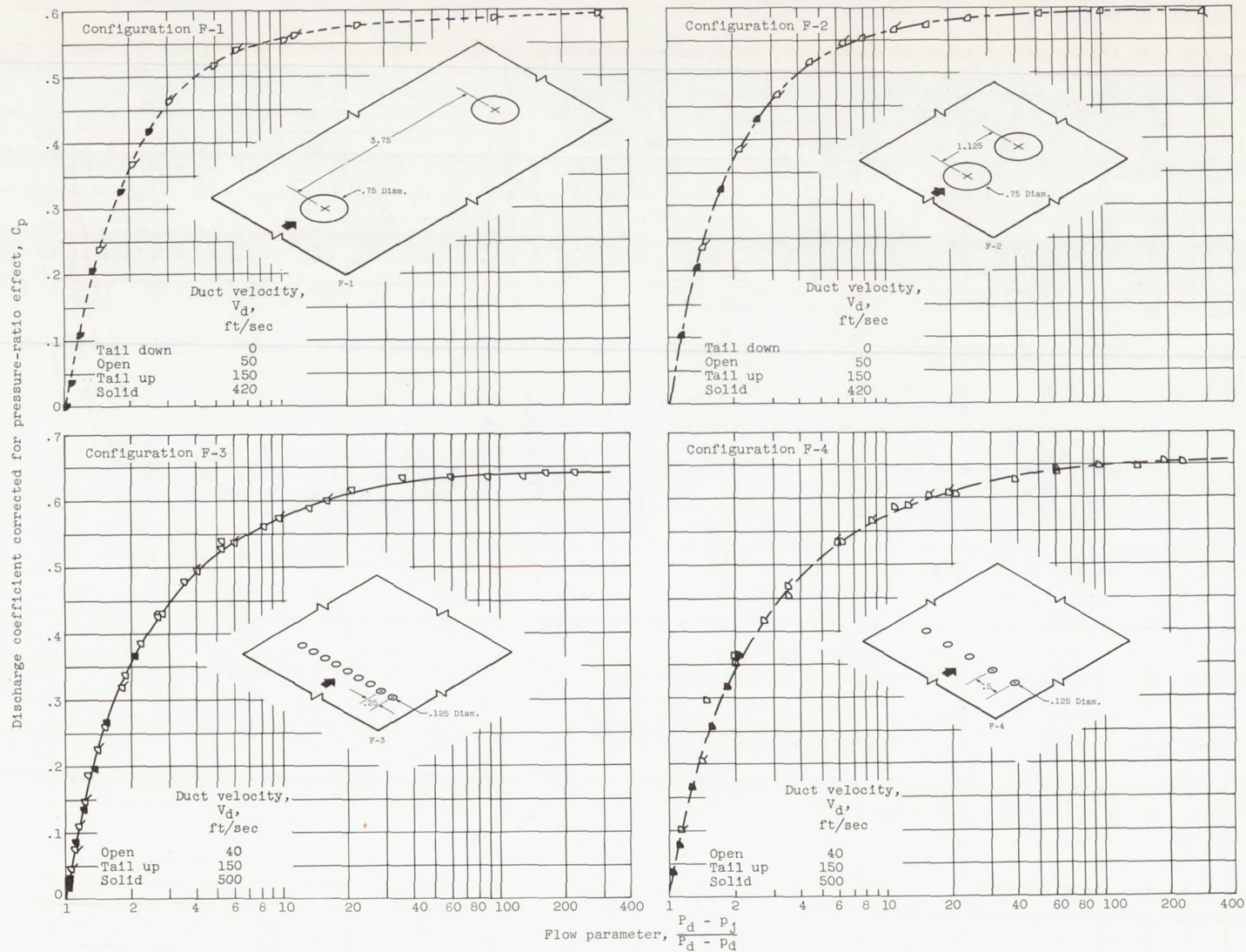

(f) Multiple circular holes.

Figure 13. - Concluded. Variation of corrected discharge coefficient with flow parameter.

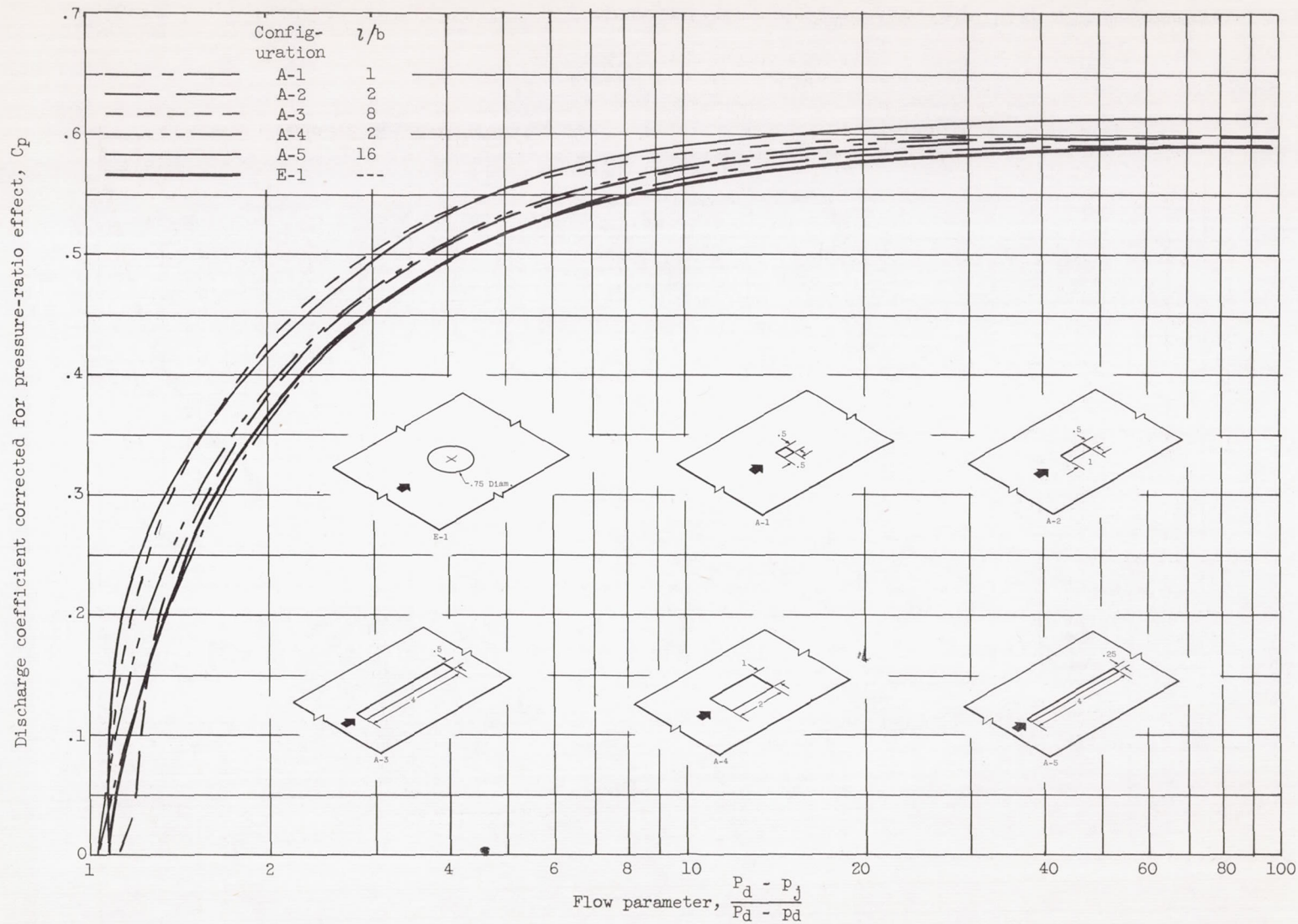

Figure 14. - Effect of flush rectangular hole dimensions on corrected discharge coefficient. (Curve for circular flush hole included for comparison.)

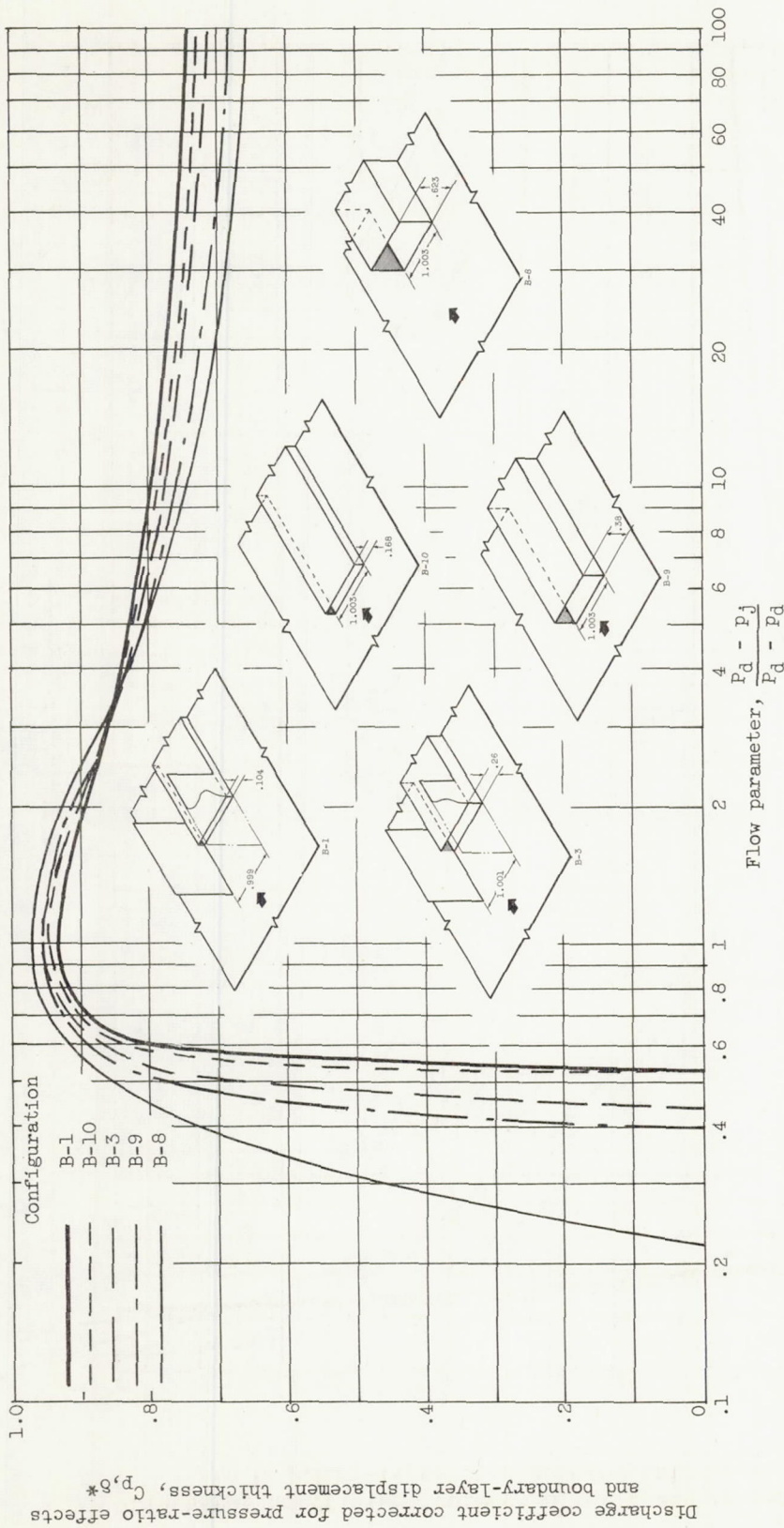
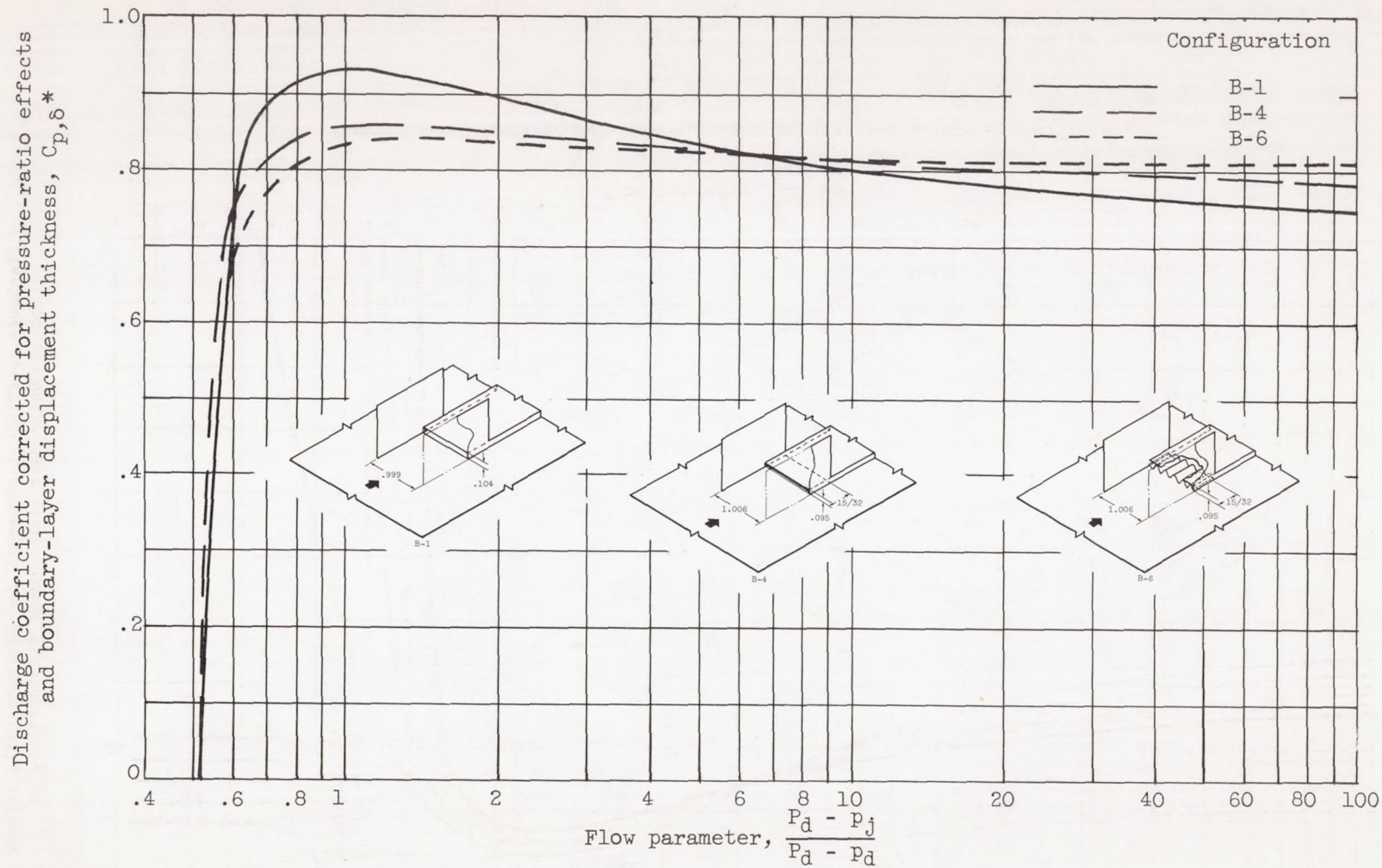

Figure 15. - Effect of step louver height on corrected discharge coefficient.



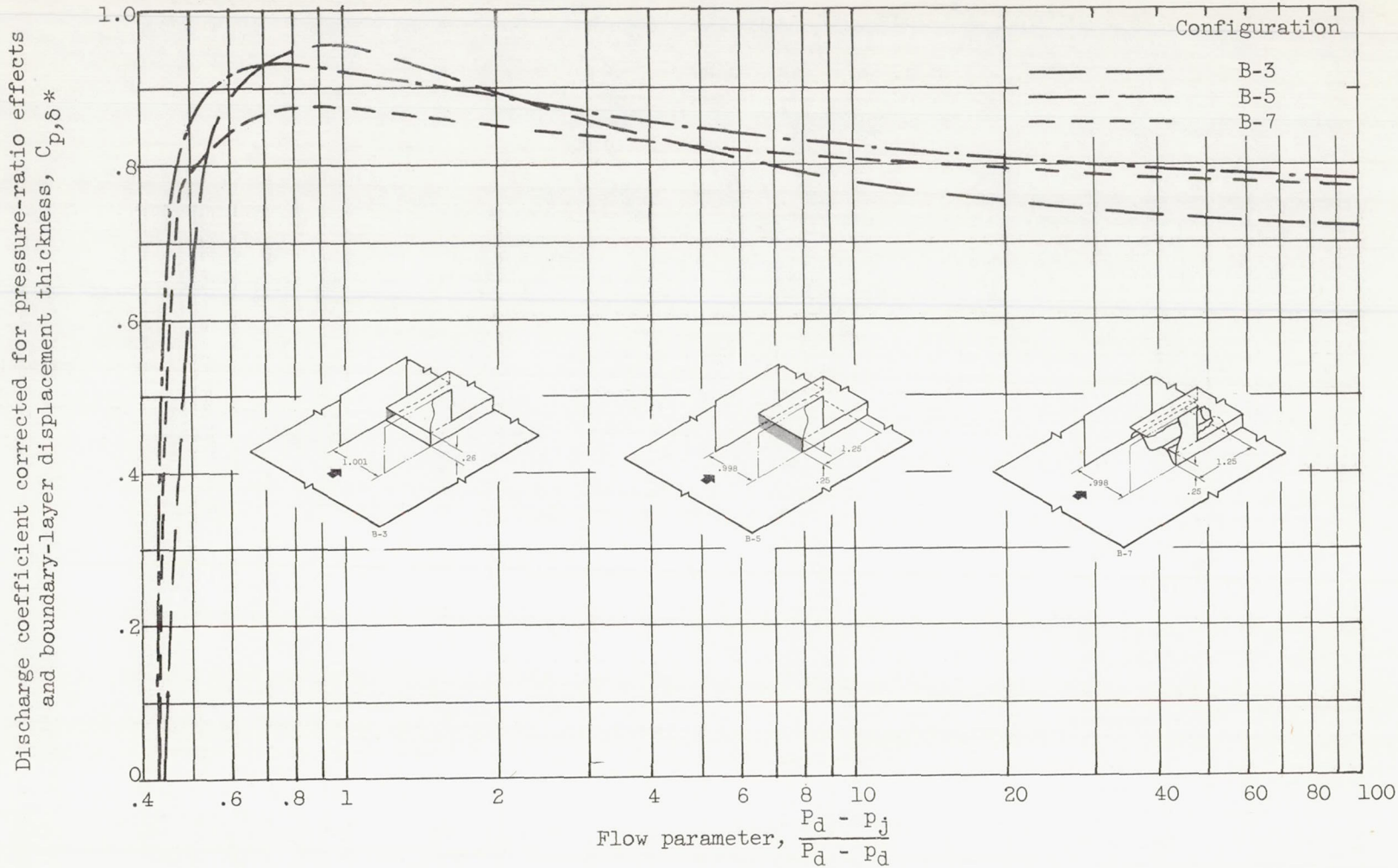

Figure 16. - Concluded. Effect of step louver overlap and corrugated spacer within the overlap on corrected discharge coefficient.

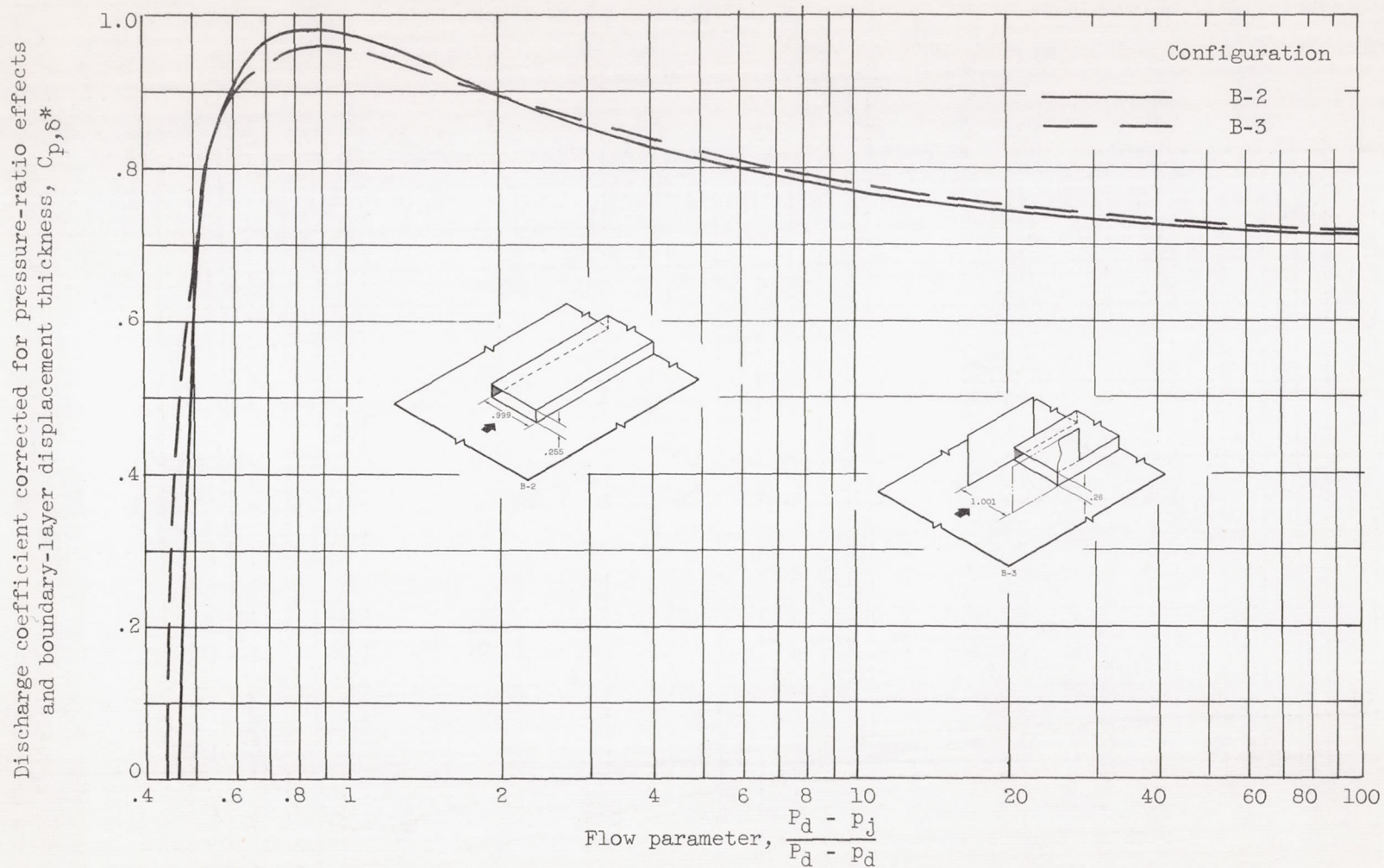

Figure 17. - Effect of side-wall extensions for step louvers on corrected discharge coefficient. Step louver height, 0.25 inch.

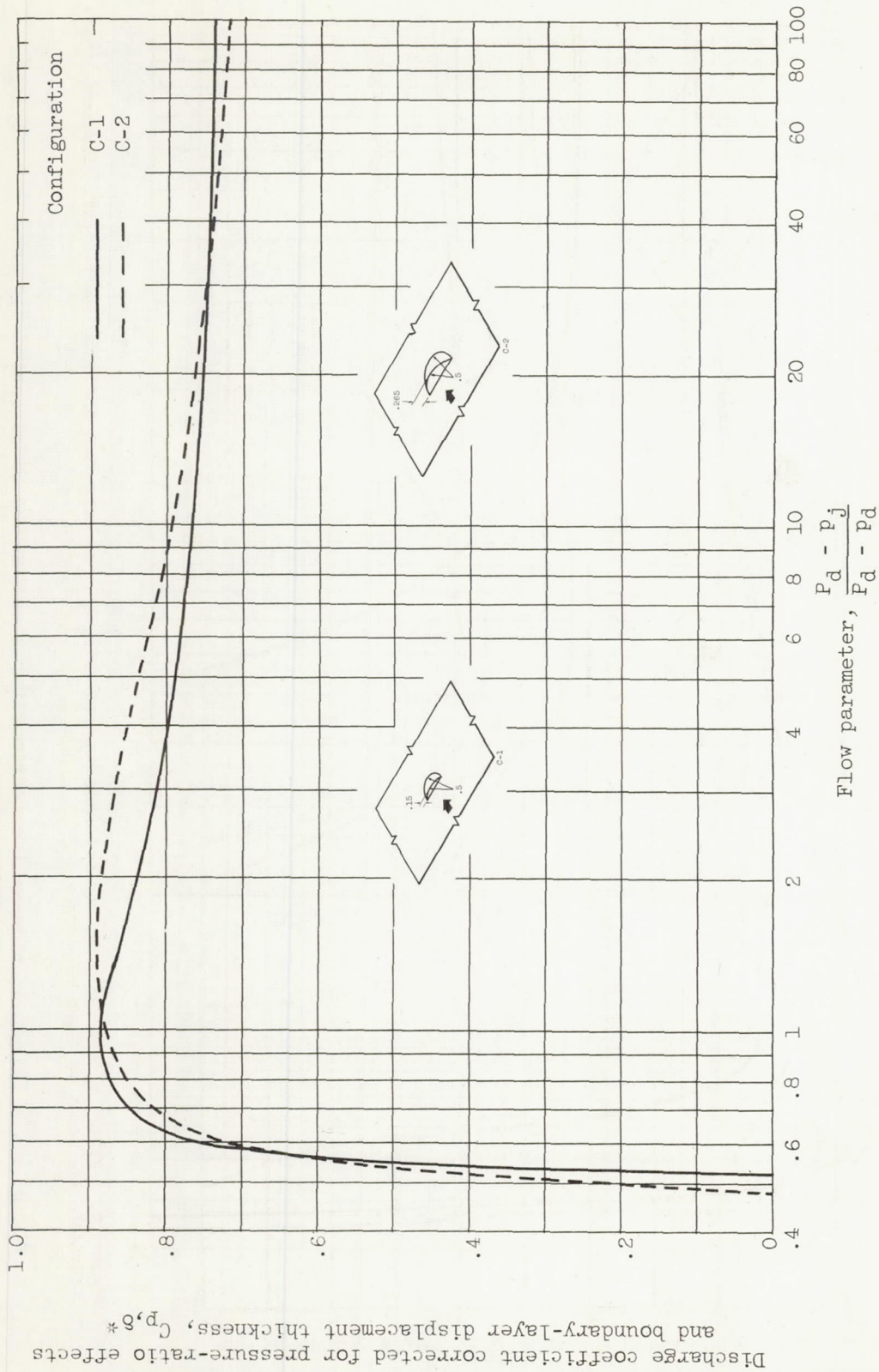

Figure 18. - Effect of height of thumbnail-type scoops on corrected discharge coefficient.

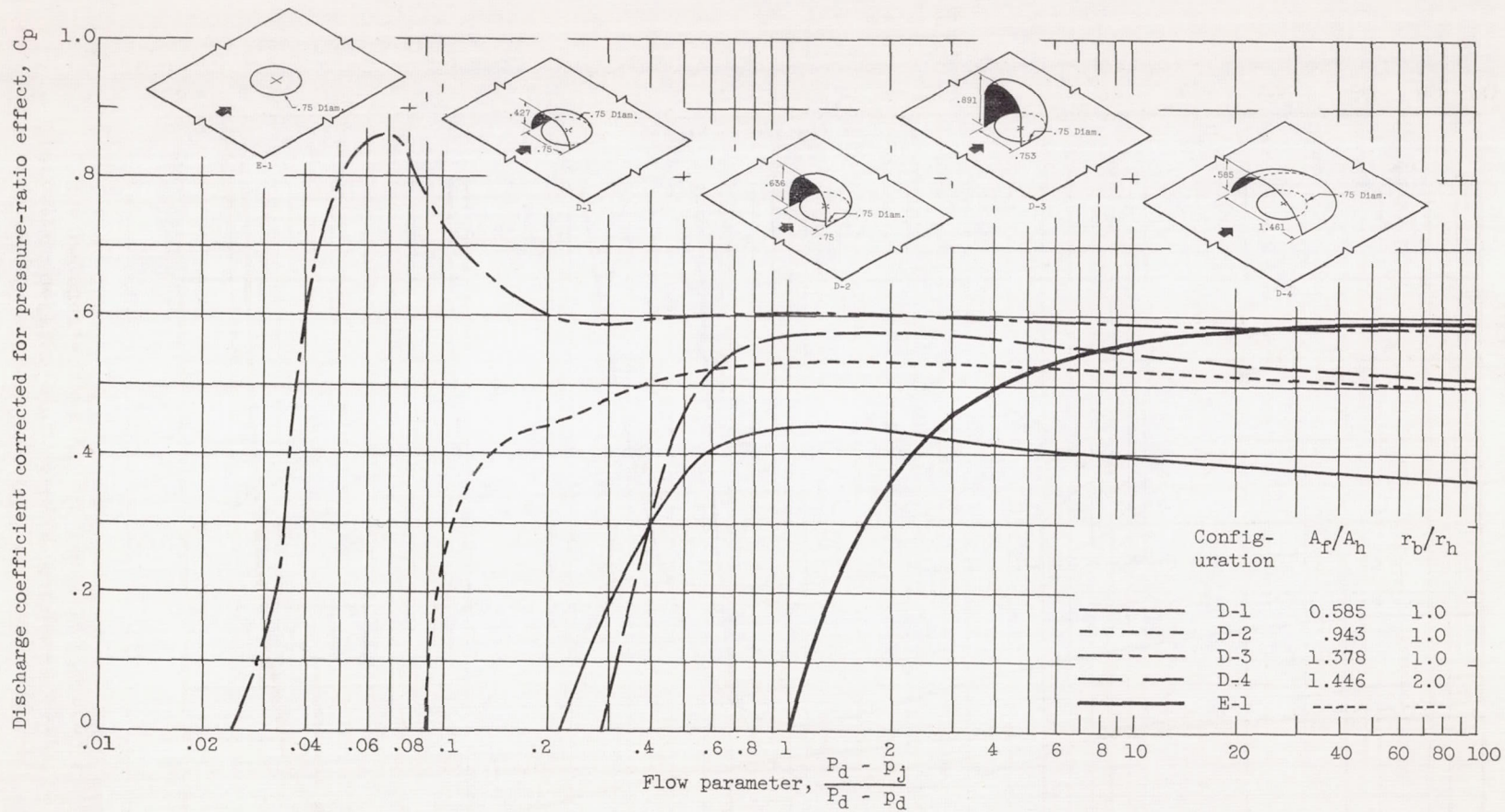

Figure 19. - Effect of size of scoop mounted over flush circular hole on corrected discharge coefficient. Discharge coefficients are based on flush hole area.

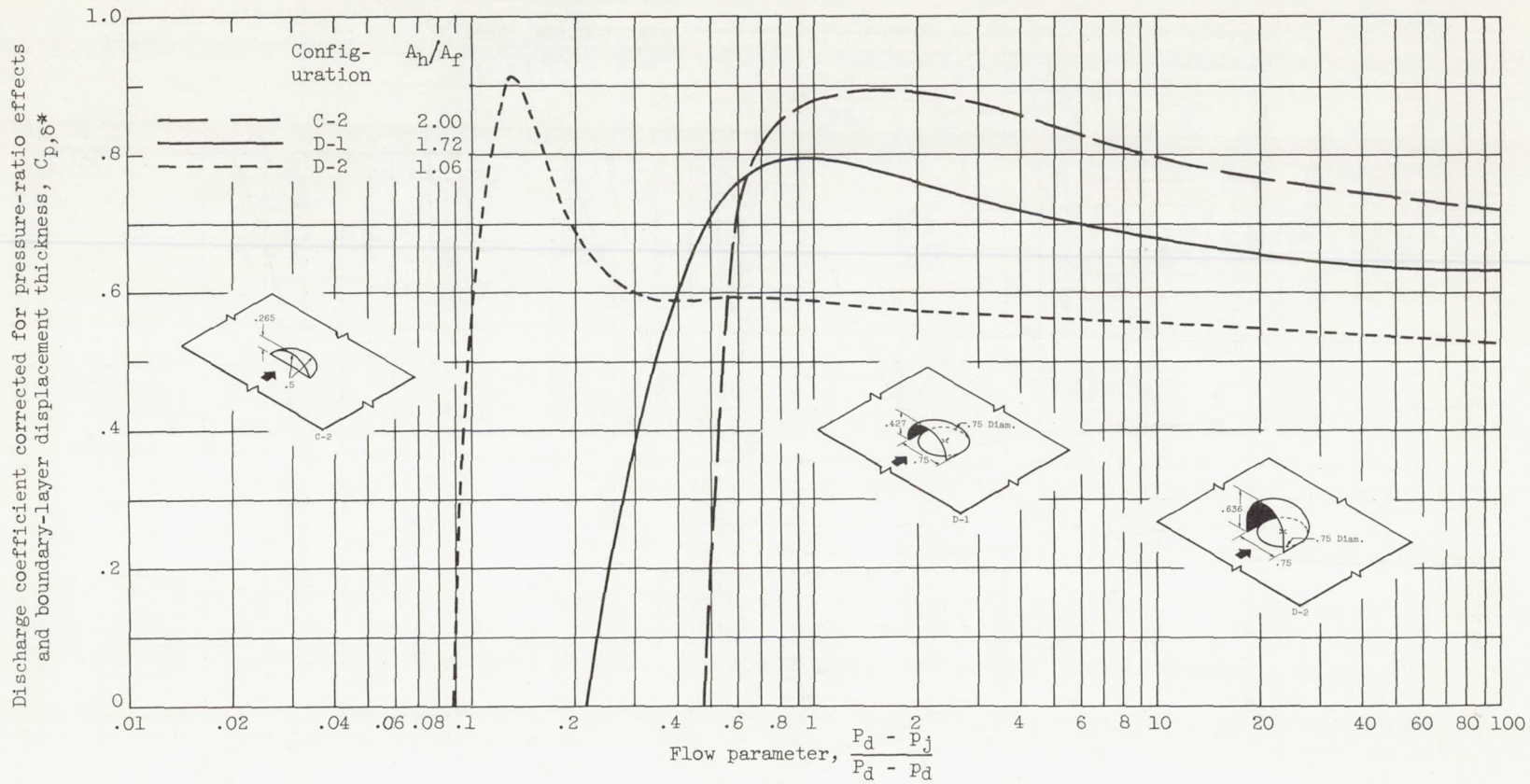
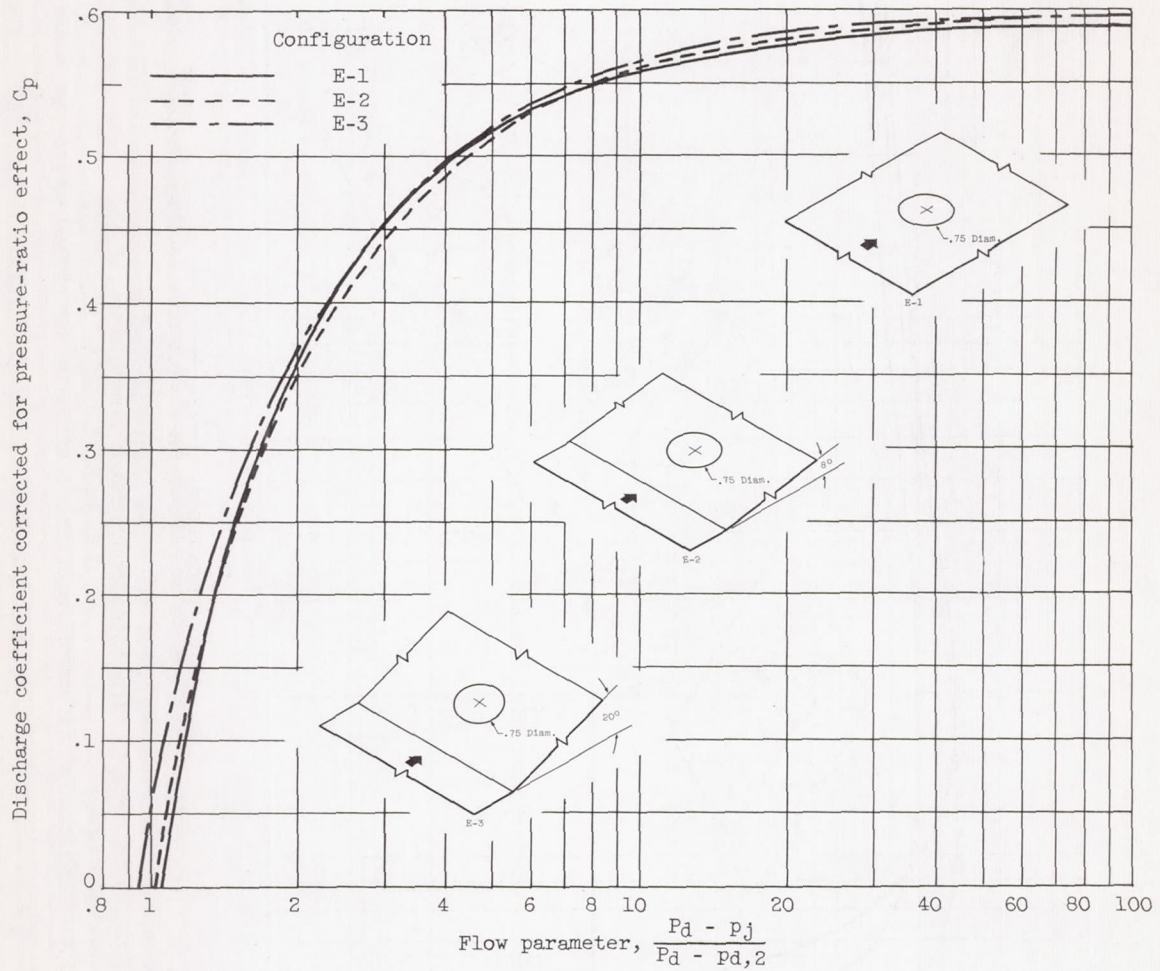

Figure 20. - Comparison of discharge coefficients for scoop-over-hole with thumbnail-type scoop. Discharge coefficients based on scoop face area.



(a) Flush circular hole with 0.75-inch diameter.

Figure 21. - Effect of wall inclination on corrected discharge coefficient.

4705

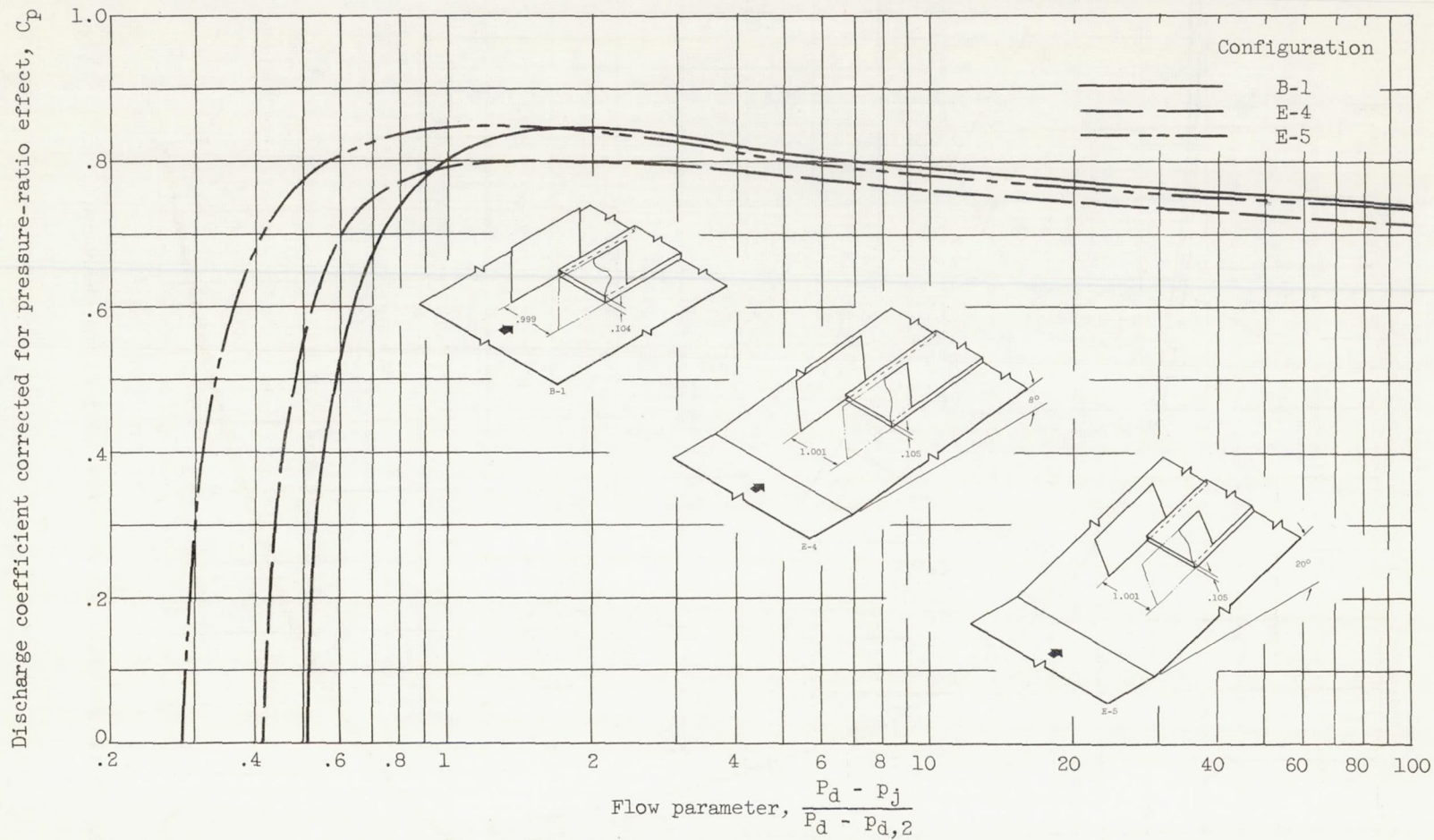

(b) Step louver 0.10 inch high.

Figure 21. - Concluded. Effect of wall inclination on corrected discharge coefficient.

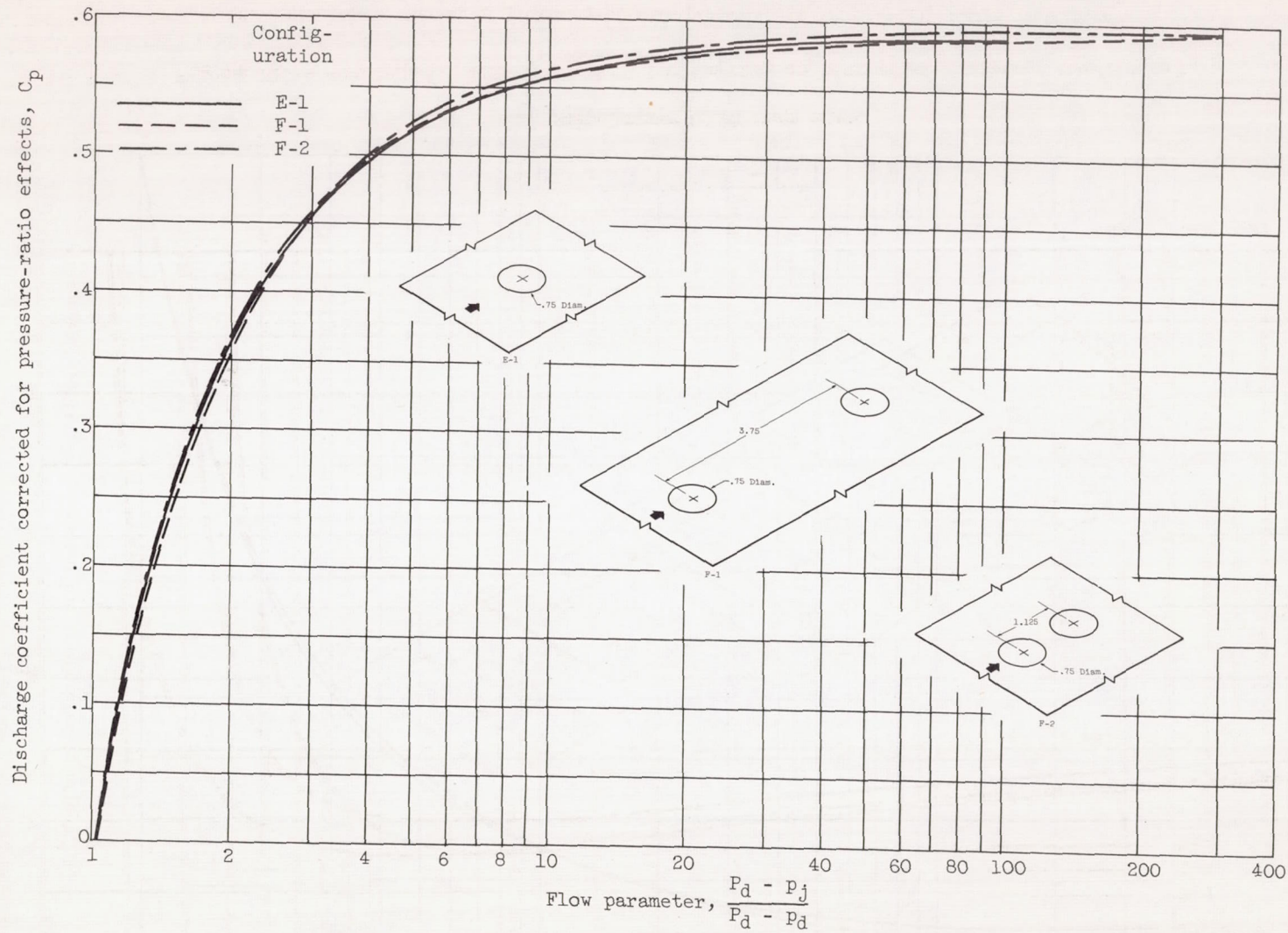

(a) Holes in line. (Configuration E-1 included for comparison.)

Figure 22. - Effect of proximity of multiple holes on corrected discharge coefficient.

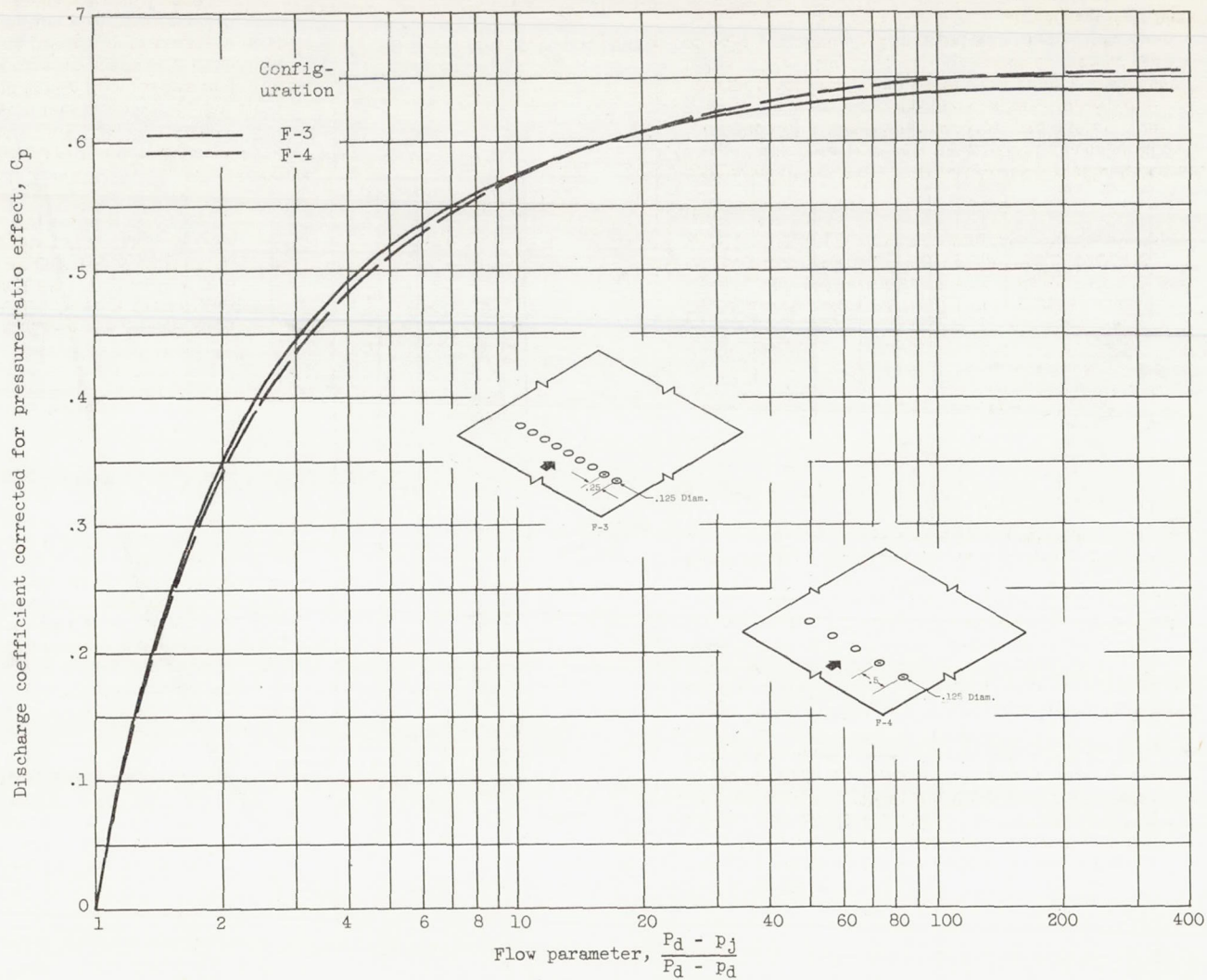

(b) Holes side by side.

Figure 22. - Concluded. Effect of proximity of multiple holes on corrected discharge coefficient.