

UNCLASSIFIED
CONFIDENTIAL

NACA RM-E7K07

COPY NO. 30
RM No. E7K07

GROUP 4
Downgraded at 3 year
intervals; declassified
after 12 years

NACA

Classification Changed to
UNCLASSIFIED
Authority
DOD DIR 5300.10
Date 10-31-64 By A mem

RESEARCH MEMORANDUM

INVESTIGATION OF THE DIBORANE - HYDROGEN PEROXIDE
PROPELLANT COMBINATION

By William H. Rowe, Paul M. Ordin
and John M. Diehl

Flight Propulsion Research Laboratory
Cleveland, Ohio

CONFIDENTIAL

JPL LIBRARY
CALIFORNIA INSTITUTE OF TECHNOLOGY

CLASSIFIED DOCUMENT

This document contains classified information affecting the National Defense of the United States within the meaning of the Espionage Act, USC 50:31 and 32. Its transmission or the revelation of its contents in any manner to an unauthorized person is prohibited by law. Information so classified may be imparted only to persons in the military and naval services of the United States, appropriate civilian officers and employees of the Federal Government who have a legitimate interest therein, and to United States citizens of known loyalty and discretion who of necessity must be informed thereof.

TECHNICAL
EDITING
WAIVED

NATIONAL ADVISORY COMMITTEE FOR AERONAUTICS

WASHINGTON
May 28, 1948

JUN 1 - 1948

CONFIDENTIAL
UNCLASSIFIED

~~UNCLASSIFIED~~
~~CONFIDENTIAL~~

NATIONAL ADVISORY COMMITTEE FOR AERONAUTICS

RESEARCH MEMORANDUMINVESTIGATION OF THE DIBORANE - HYDROGEN PEROXIDE
PROPELLANT COMBINATIONBy William H. Rowe, Paul M. Ordin
and John M. Diehl

SUMMARY

Two runs were made with liquid diborane and hydrogen peroxide in a small-scale experimental rocket engine. After the first run, which was very erratic, several modifications were made to the apparatus and test procedure. In the second run combustion started immediately and continued smoothly for the 12 seconds of operation. The diborane - hydrogen peroxide weight ratio investigated was 0.27 (stoichiometric, 0.136). The maximum experimental specific impulse attained during the run was 211 pound-seconds per pound for a combustion-chamber pressure of 237 pounds per square inch gage. This experimental specific impulse was 81 percent of the theoretical specific impulse for the same mixture ratio and combustion-chamber pressure.

INTRODUCTION

The use of diborane (B_2H_6) as a rocket fuel is of current interest because of the large amount of energy per unit weight available from its reaction with oxidants. The thermodynamic properties and gaseous equilibriums of boron and the oxides of boron have been determined by the National Bureau of Standards (reference 1). Considerable work in connection with the chemistry of boron and boron compounds has been conducted by Schlesinger and associates at the University of Chicago. In addition, the investigation to determine many of the physical, chemical, and physiological properties of diborane is being sponsored by the Naval Research Laboratory, Washington, D. C. Few experimental investigations, however, of the performance of diborane as a rocket fuel have been conducted.

The experimental results of two runs conducted at the NACA Cleveland laboratory using 95-percent liquid diborane and 87-percent

~~UNCLASSIFIED~~
~~CONFIDENTIAL~~

hydrogen peroxide in a 100-pound thrust rocket engine are presented herein. Also presented are theoretical values of specific impulse, reaction-chamber temperature, and exhaust temperature for the operating conditions of one of the runs.

APPARATUS AND PROCEDURE

A diagrammatic sketch of the 100-pound thrust rocket unit illustrating the propellant (catalyst, fuel, and oxidant) systems and the gas pressurizing systems used for pumping the propellants is shown in figure 1. The entire apparatus was mounted on a stand that was pivoted to permit horizontal motion.

The oxidant (87-percent hydrogen peroxide) and catalyst (44-percent calcium-permanganate solution) were contained in stainless-steel tanks. A chrome-molybdenum steel tank (fig. 2) was used to hold the fuel (95-percent diborane B_2H_6). The fuel tank was equipped with a stainless-steel bursting disk and high-pressure stainless-steel hand valves that were packed with Teflon, a polytetrafluoroethylene plastic. Check valves were installed in each of the propellant lines. The fuel tank and lines were refrigerated with dry ice to maintain the diborane (boiling point, $-134.5^\circ F$ at 1 atmosphere) in a liquid state up to the injector plate.

The oxidant and catalyst supply tanks were pressurized with water-pumped nitrogen gas from a common nitrogen supply and the fuel supply tank was pressurized with oxygen-free helium. The gas pressure to each of the propellant tanks was controlled with two-stage pressure regulation.

A detailed sketch of the 100-pound-thrust rocket engine is shown in figure 3. The engine comprises a stainless-steel injector plate containing six solid-jet injector nozzles, a thick-walled copper combustion chamber with an inside diameter of $2\frac{1}{4}$ inches and a length of $18\frac{3}{8}$ inches, and a convergent-divergent copper exhaust nozzle designed to provide complete expansion at a pressure ratio of 20.4. The two diborane injector nozzles were located diametrically opposite to each other and produced impinging jets meeting approximately $\frac{3}{8}$ inch upstream of the point of impingement of the four hydrogen-peroxide injector nozzles. The hydrogen-peroxide injector nozzles were located 90° apart on a radius outside that of the fuel nozzles. The catalyst was injected through a hole in

851

the center of the injector plate. The inner walls of the combustion chamber and exhaust nozzle were chrome-plated to resist corrosion and erosion. The ratio of the combustion-chamber volume (up to the throat of the exhaust nozzle) to the cross-sectional area of the exhaust nozzle throat was 255 inches.

Thrust was measured by means of two strain gages mounted on a bar subjected to bending by the engine thrust. (See fig. 1.) The two gages were connected in a resistance bridge circuit of a modified, continuous-recording, self-balancing potentiometer, which traced a thrust-time relation. Propellant consumption was determined by differences in weights before and after the run. Specific impulse, defined as the thrust per unit rate of propellant consumption, was obtained by integrating the thrust-time diagram with a planimeter and dividing by the propellant consumption. Combustion pressure was measured by a Bourdon-type pressure recorder. Propellant-supply pressures were recorded by taking motion pictures of the Bourdon gages. Color motion pictures were taken of the exhaust flame.

Prior to operation, the oxidant and catalyst systems were loaded and the diborane feed system was flushed with oxygen-free helium. The diborane tank was then removed from dry-ice storage, weighed, placed in a dry-ice-alcohol bath, and connected to the feed system.

For the first run, the catalyst (44-percent solution of calcium permanganate) was injected first; after a delay of about 2 seconds, the injection of 87-percent hydrogen peroxide followed. After another delay of approximately 2 seconds, the liquid diborane was admitted and the catalyst flow immediately shut off. A fuel-oxidant weight ratio of 0.67 was selected, which would permit a burning time of approximately 5 seconds for the quantity of diborane provided.

For the second run, several changes were made to the apparatus and the firing procedure: (1) The type of air-operated diborane control valve was changed; (2) the catalyst injection was omitted; (3) nozzle sizes were changed for a fuel-oxidant weight ratio of 0.27 (stoichiometric, 0.136), which would permit a burning time of approximately 12 seconds for the quantity of diborane provided; (4) the motor was heated by a hand torch just prior to the loading of the diborane to facilitate the initial decomposition of the hydrogen peroxide; and (5) the diborane and hydrogen peroxide were injected simultaneously into the preheated engine.

RESULTS AND DISCUSSION

Poor performance and erratic burning were obtained in the first run and data required to evaluate the performance of the propellant combination could not be obtained. The white smoky appearance, typical of straight peroxide runs, changed to a clear green flame when the diborane was injected; but the flame varied in intensity and burning pieces of molten boron or boron compounds were observed to drop from the exhaust nozzle during the run. Although for the intended fuel-oxidant weight ratio of 0.67 the burning time should have been only 5 seconds, there was no indication of cessation of burning at the end of 25 seconds at which time the propellant systems were shut off. Smoke issued from the exhaust nozzle and burned upon contact with the air for about $1\frac{1}{2}$ hours after the propellant systems were shut off.

After the first run, the exhaust nozzle was completely clogged with a hard brown solid and the inside of the rocket engine was completely coated with a soft, white, fluffy deposit approximately $1/4$ inch thick under which was a layer of a dark brown hard substance (fig. 4). The hydrogen-peroxide injectors were clean but the tips of the diborane injectors were filled with a solid white deposit. The lines, the air-operated valve, and the check valve of the diborane system had a very fine yellowish-white coating on the inside surfaces. The erratic operation was attributed to a reduced and an intermittent flow of diborane, which may have been caused by decomposition of the diborane in the injectors or by faulty operation of the air-operated control valve, or both.

In the second run, in which the diborane and hydrogen peroxide were injected simultaneously, immediate and smooth combustion occurred. The exhaust flame was a brilliant green with many luminous particles clearly recorded by the color motion pictures. An enlargement of a frame from the motion pictures is presented in figure 5. The luminous particles in the exhaust flame are probably deposits originally formed on the engine walls and products of combustion condensed or solidified by the decrease in temperature during the expansion process through the exhaust nozzle. Thrust and combustion pressure increased progressively during the 12 seconds of operation, followed by slight afterburning, which occurred for about 5 seconds.

Experimental thrust and combustion-chamber pressure, propellant flow rates, and experimental and theoretical values of specific impulse for the second run are plotted against running time in

851

figure 6. Thrust and combustion-chamber pressure increase rapidly for the first $1\frac{1}{2}$ seconds, after which time both curves have a marked tendency to approach a level. The propellant-flow-rate curves were plotted from data of the combustion-chamber pressure, injection pressures, total propellant consumptions, and total time. The propellant flow rates were high at the start of the run because of the high differential pressure across the injection nozzles due to the low combustion-chamber pressure; but after the first $1\frac{1}{2}$ seconds, these flow rates tended to level off at lower steady values for the duration of the run.

A corresponding change is seen in the experimental specific-impulse curve obtained from the thrust and total-propellant-consumption data. During the first second of the run, the values of thrust and combustion-chamber pressure were low, and the propellant consumption rate was high; consequently, the specific impulse was low. As the combustion-chamber pressure and thrust increased and the total propellant consumption rate dropped, the specific impulse rose. Values for the theoretical specific-impulse curve were calculated for the experimental mixture ratio and combustion pressures using the data of references 1 and 2. It was assumed that all products of reaction were ideal gases and that no recombination or condensation occurred during expansion. The maximum experimental specific impulse value of 211 pound-seconds per pound is approximately 81 percent of the maximum theoretical value of 262-pound-seconds per pound for the mixture ratio investigated. As is to be expected, the low combustion and nozzle efficiencies of the first part of the run are made evident from a comparison of the specific-impulse curves.

A contributing factor to the initial low performance is the poor mixing and combustion resulting from the use of only two solid-jet injector nozzles for the diborane and four for the hydrogen peroxide. With better injection, starting and over-all efficiency could be improved. It should be noted that the mixture ratio investigated is not the optimum for this fuel-oxidant combination.

The performance data for the second run are summarized in the following table:

Diborane - hydrogen peroxide weight ratio	0.27
Maximum thrust, (lb)	68
Maximum combustion-chamber pressure, (lb/sq in. gage)	237
Maximum specific impulse, (lb-sec/lb)	211
Reaction temperature (calculated for maximum specific impulse), °F	4995
Exhaust temperature (calculated for maximum specific impulse), °F	2972

As a result of the second run, the walls of the rocket engine were coated with a 1/8- to 1/16-inch gray-to-dark brown, hard layer of boron and boron oxides (fig. 7). At the injection end of the engine and for the first 3 or 4 inches downstream, the deposit was rough and uneven in thickness and gray in color. On the remainder of the engine up to the exhaust-nozzle throat, which was clean, the coating gradually became dark brown, smooth, and more even in thickness with many gas pockets and a surface glaze. The smooth, glazed coating, especially in the vicinity of the convergent section of the exhaust nozzle, was probably formed by heat and flowing gases during the second run.

SUMMARY OF RESULTS

From two runs using approximately 95-percent liquid diborane and 87-percent hydrogen peroxide in an experimental 100-pound thrust rocket engine, the following results were obtained:

1. During the first run, in which hydrogen peroxide and a catalyst were injected prior to the diborane, very erratic combustion attributable to a faulty supply of diborane was produced.

2. For the second run, in which the catalyst was omitted and hydrogen peroxide and diborane were injected simultaneously, immediate and smooth combustion was obtained for the duration of the run (12 sec). The diborane - hydrogen peroxide weight ratio was 0.27 (stoichiometric, 0.136), the maximum combustion-chamber pressure was 237 pounds per square inch gage, and the specific impulse was 211 pound-seconds per pound, which is 81 percent of the theoretical specific impulse for these operating conditions.

3. The engine was much cleaner after the second run than after the first. For the second run, a layer of boron and boron oxide 1/16 to 1/8 inch thick was deposited on most of the engine surfaces with only a negligible amount of deposit on the exhaust-nozzle throat.

Flight Propulsion Research Laboratory,
National Advisory Committee for Aeronautics,
Cleveland, Ohio.

REFERENCES

1. Wacker, Paul F., Wooley, Harold W., and Fair, Myron F.: Thermodynamic Properties and Gaseous Equilibria of Boron, Oxygen and the Oxides of Boron. Tech. Rep., Nat. Bur. Standards, Heat and Power Div., Jan. 25, 1945. (Bur. Aero., Navy Dept.)
2. Hirschfelder, J. O., McClure, F. T., Curtiss, C. F., and Osborne, D. W.: Thermodynamic Properties of Propellant Gases. NDRC Rep. No. A-116, Nov. 23, 1942. (Extension and Revision of NDRC Rep. No. A-48 (OSRD No. 547).) (Abs. in Bib. Sci. and Ind. Repts., vol. 2, no. 10, Sept. 6, 1946, p. 743, PB 28531.)

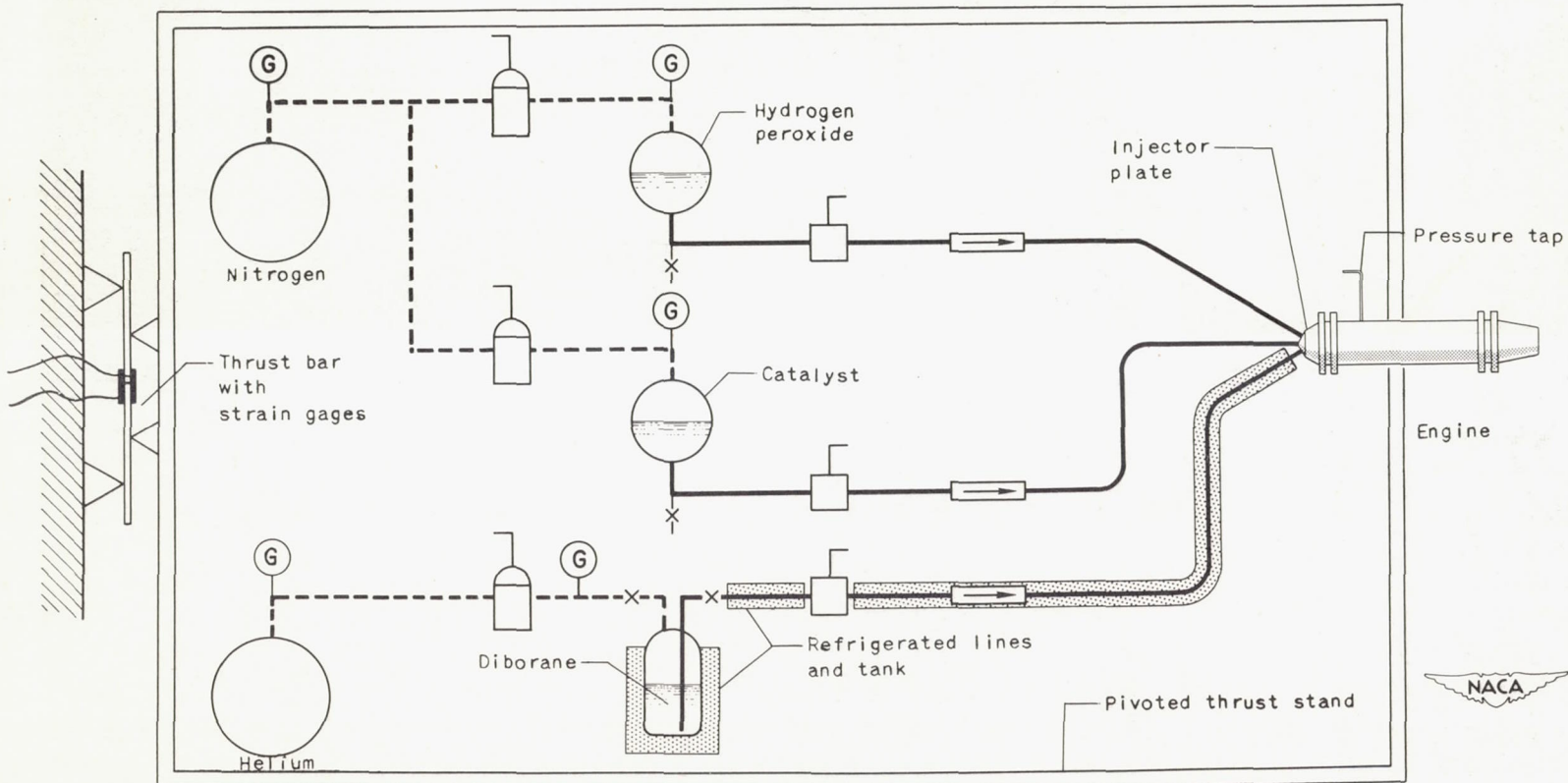
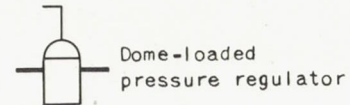
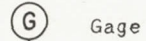
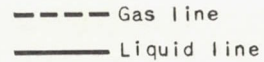
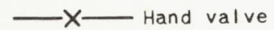
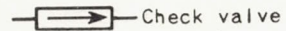
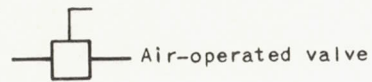

Figure 1. - Diagrammatic sketch of 100-pound-thrust rocket unit.

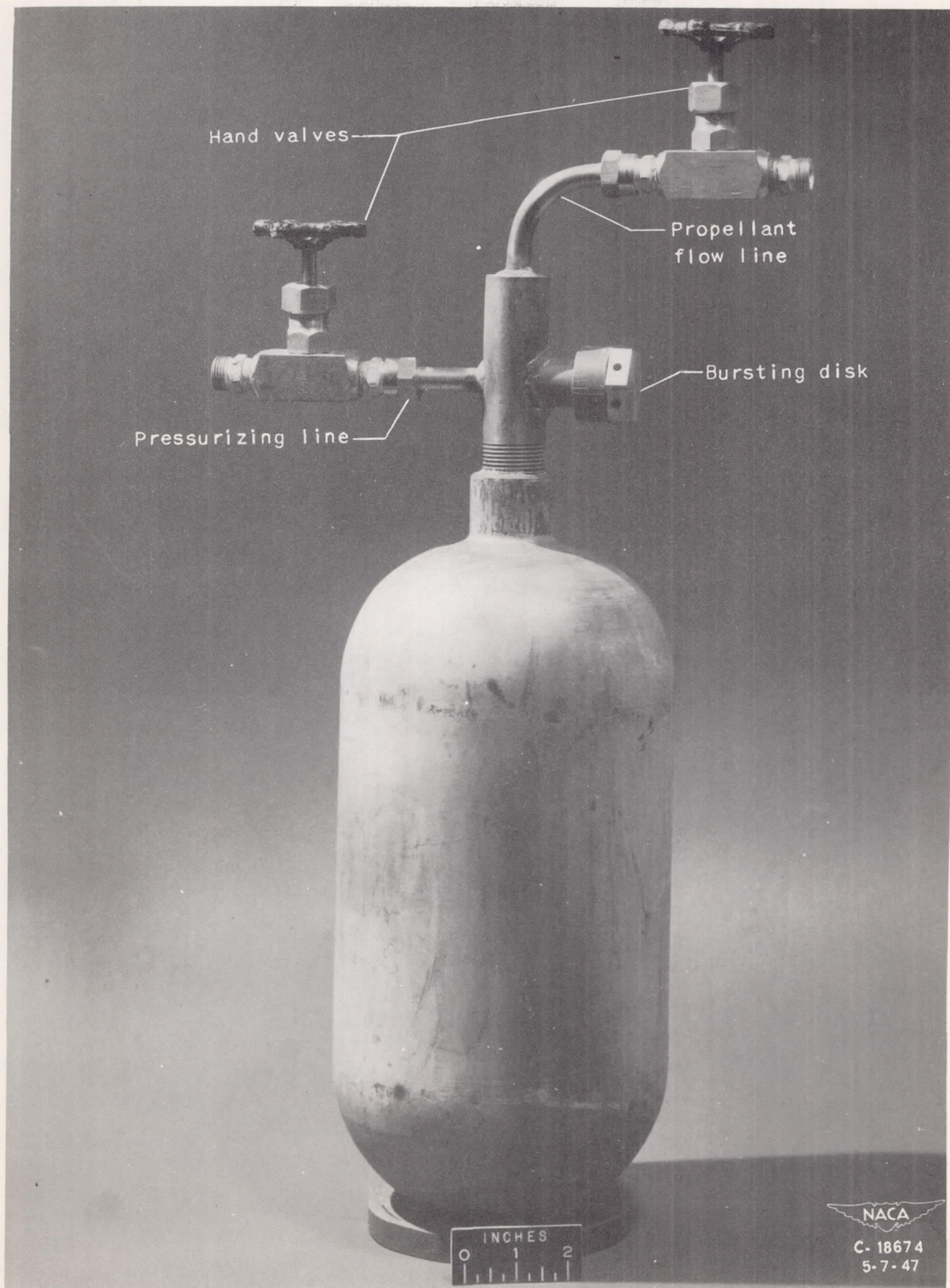
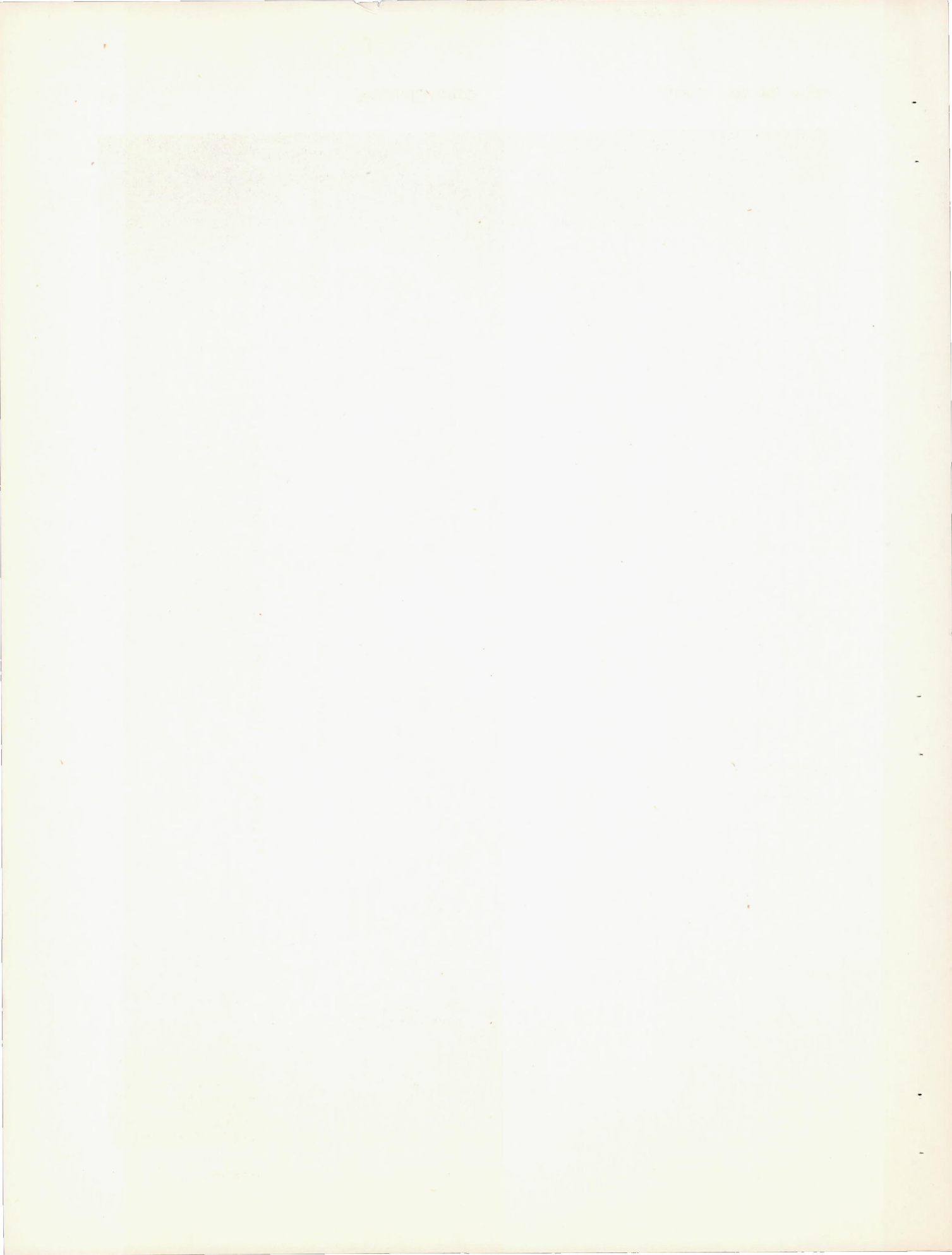
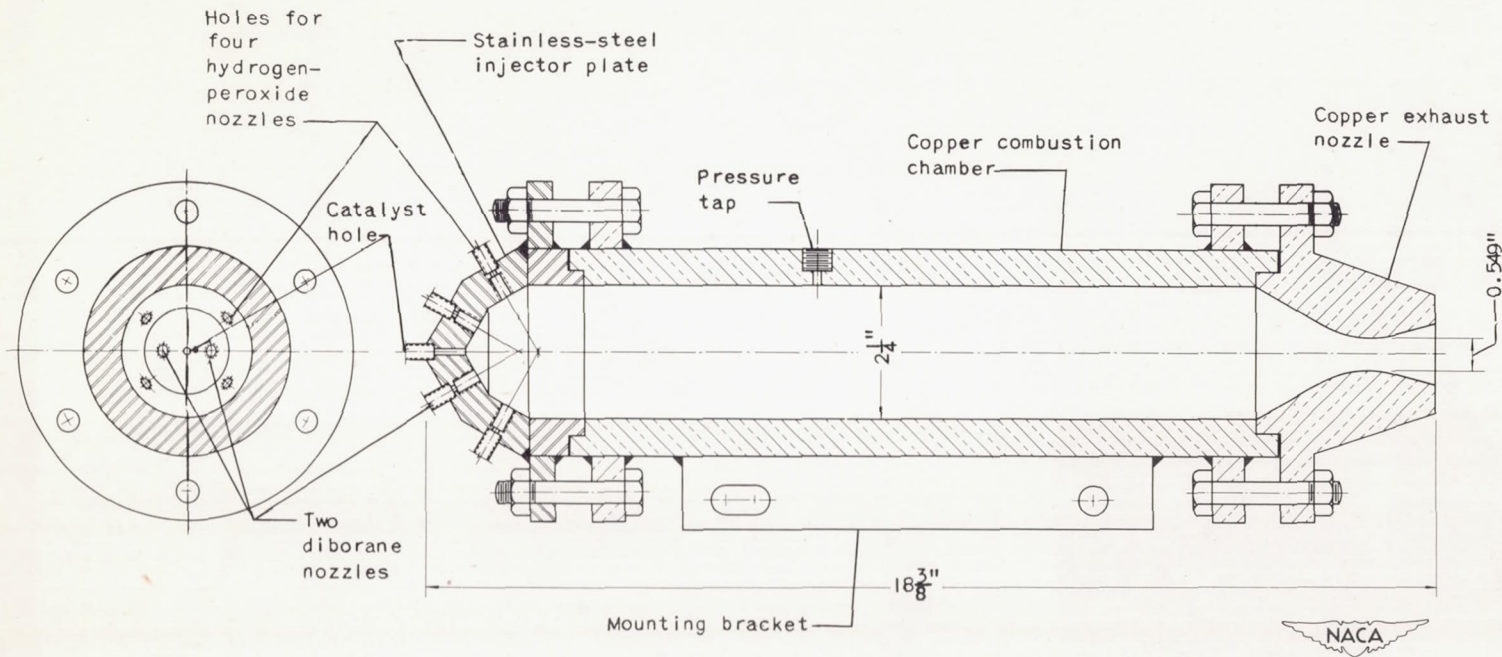

Figure 2. - Chrome-molybdenum steel tank for diborane.





CONFIDENTIAL

Figure 3. - 100-pound thrust rocket engine.

1912

1912

128

1912

CONFIDENTIAL

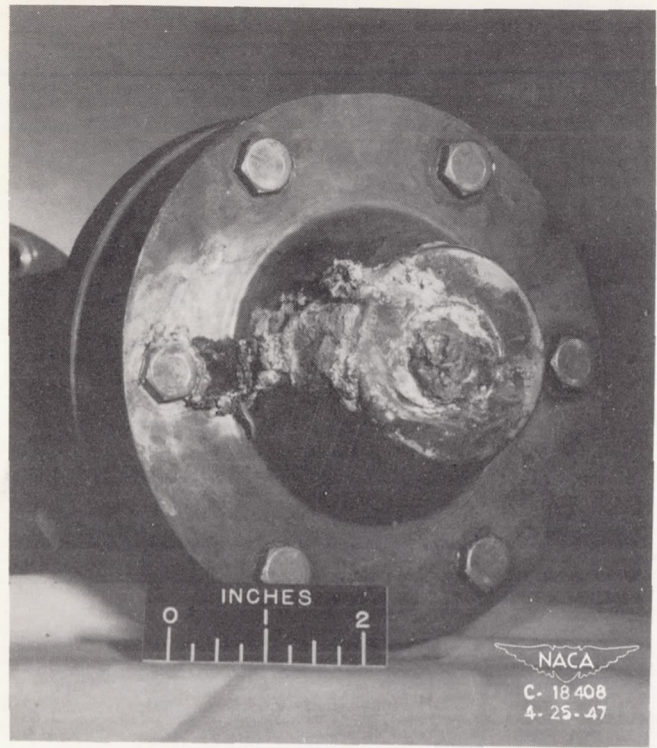

(a) Exhaust nozzle.

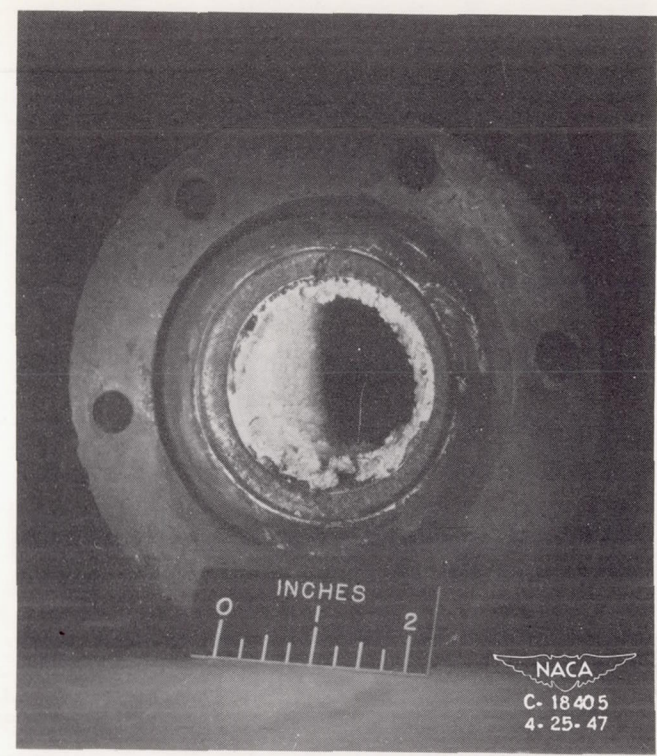

(b) Chamber wall of injection end.

Figure 4. - Deposit on rocket engine after first run.

CONFIDENTIAL

1870-1871

1870-1871

1870-1871

1870-1871

1870-1871

851

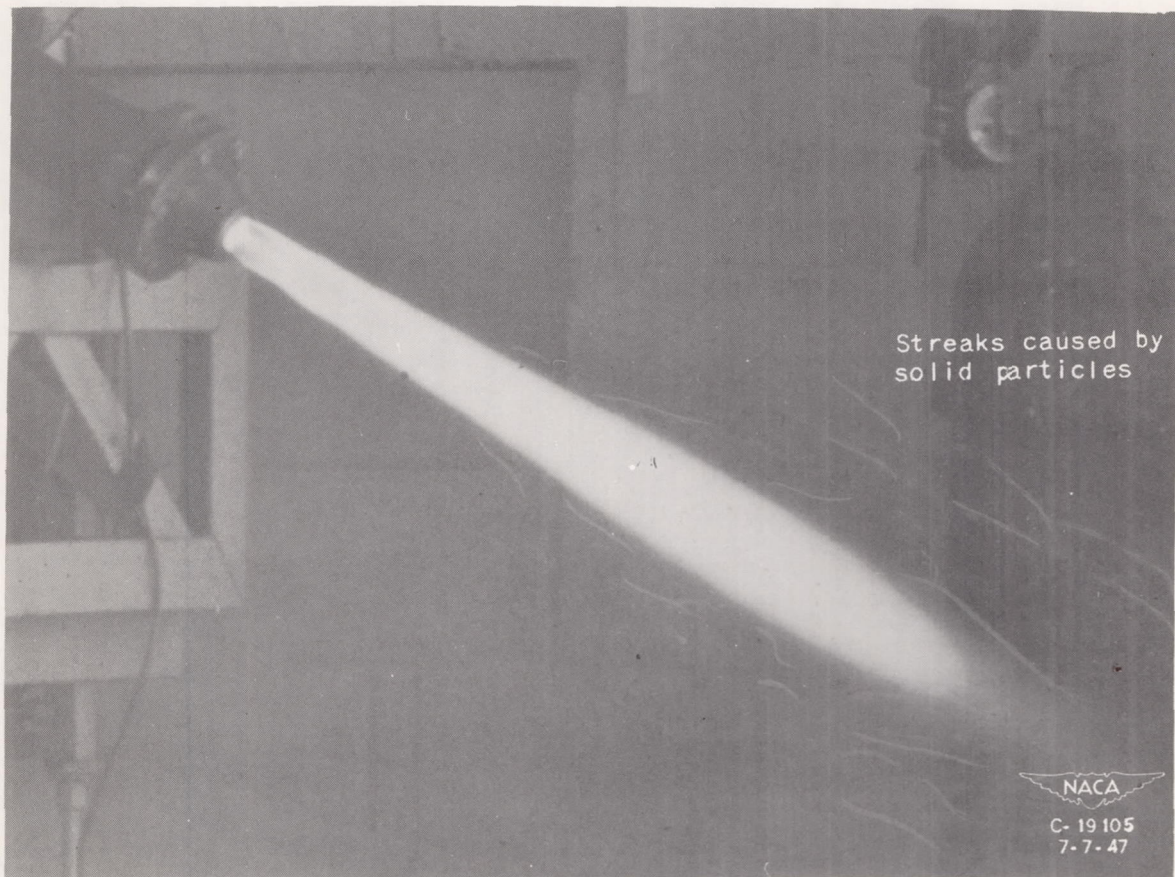
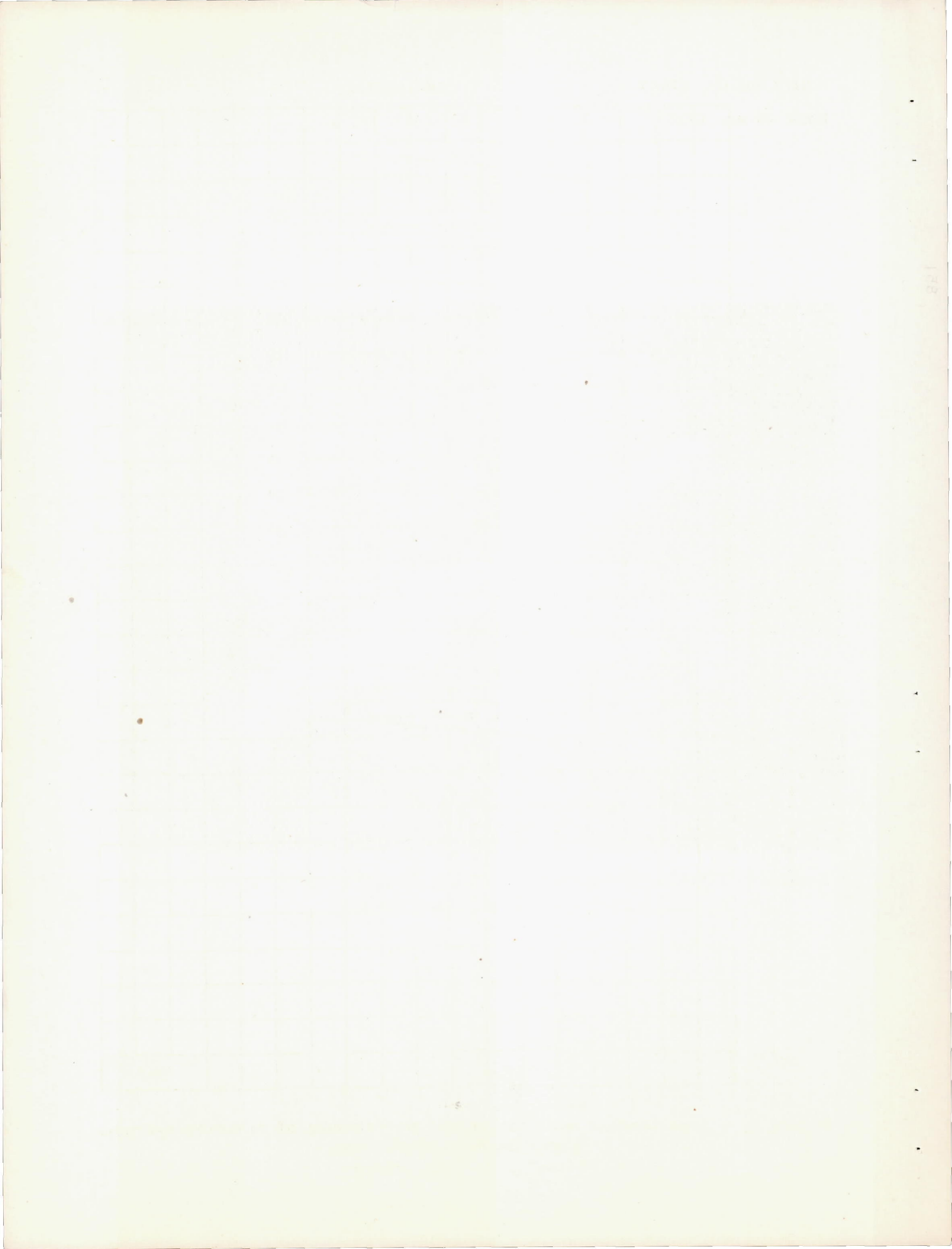

Figure 5. - Exhaust flame of diborane-hydrogen peroxide. (Enlargement of 16 mm color movie frame.)



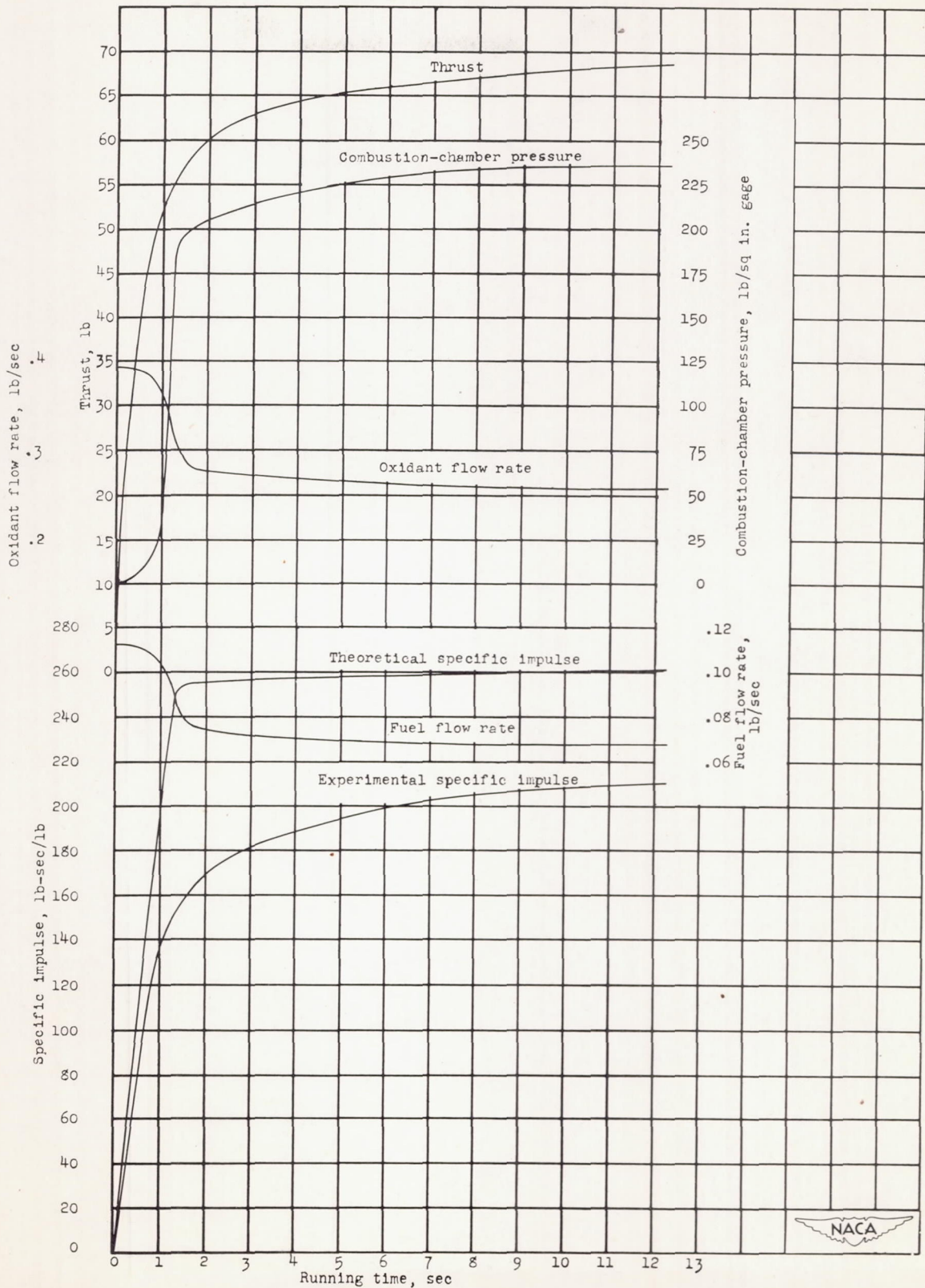
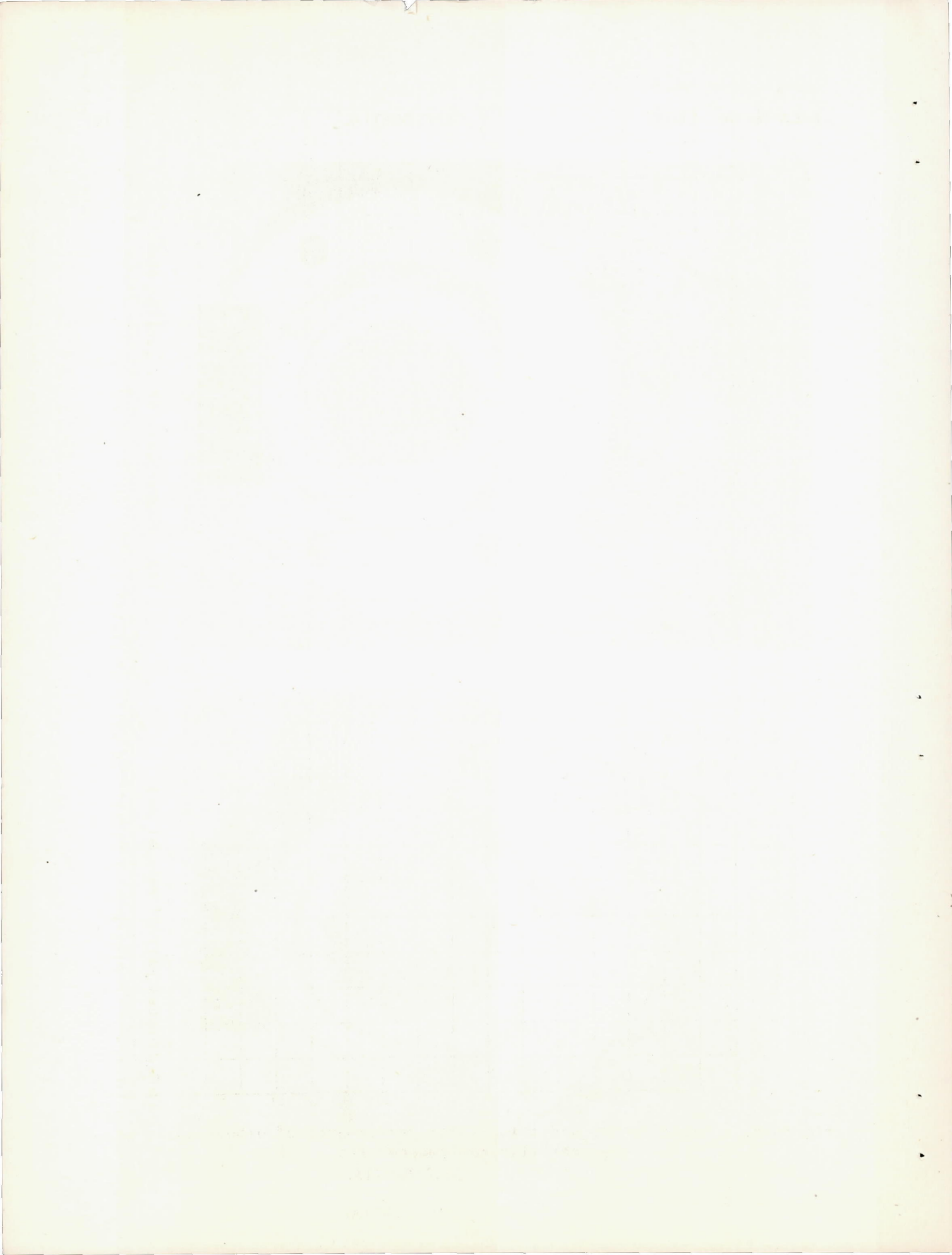
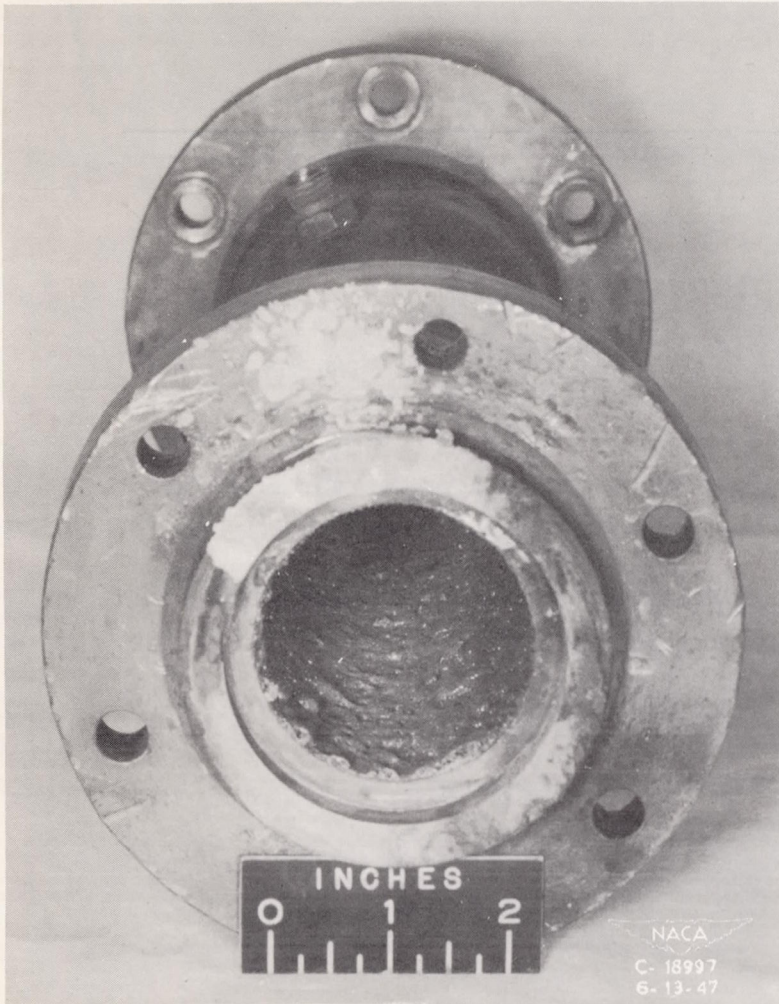
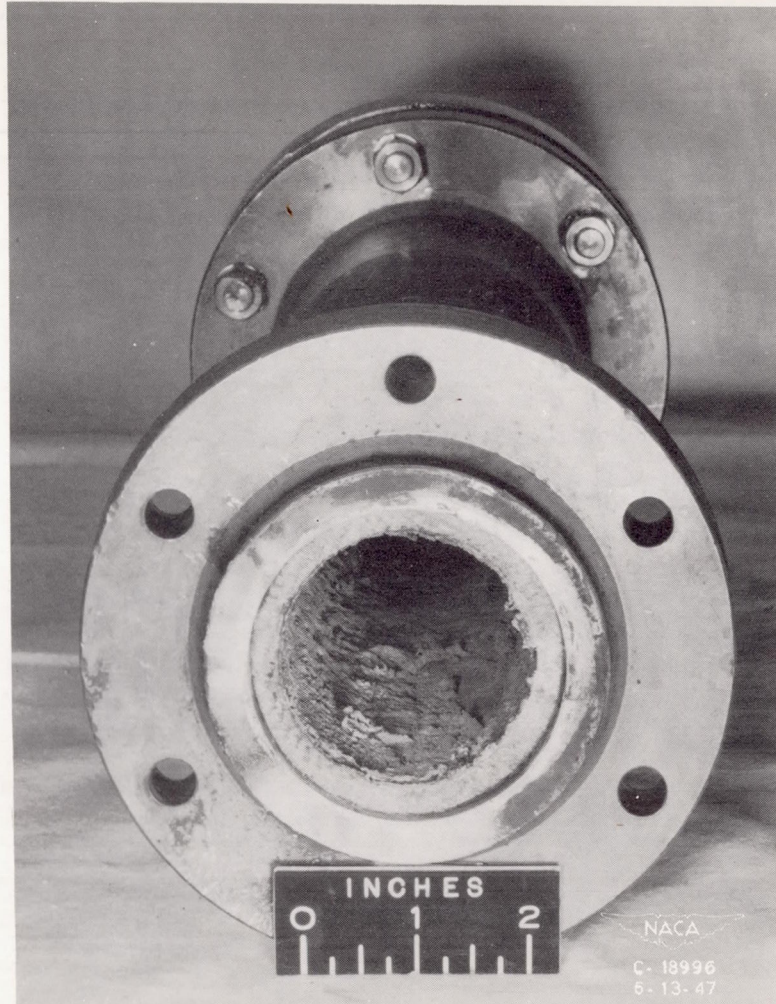

Figure 6. - Experimental and theoretical performance of diborane-hydrogen peroxide for second run.





(a) Chamber wall of exhaust end.



(b) Chamber wall of injection end.

Figure 7. - Deposit on walls of rocket engine after second run.