

# RESEARCH MEMORANDUM

EXPERIMENTAL INVESTIGATION OF LIQUID DIBORANE - LIQUID OXYGEN  
PROPELLANT COMBINATION IN 100-POUND-THRUST ROCKET ENGINE

By William H. Rowe, Paul M. Ordin, and John M. Diehl

Lewis Flight Propulsion Laboratory  
Cleveland, Ohio

**NATIONAL ADVISORY COMMITTEE  
FOR AERONAUTICS  
WASHINGTON**

May 9, 1949  
Declassified March 19, 1957

NATIONAL ADVISORY COMMITTEE FOR AERONAUTICS

RESEARCH MEMORANDUM

EXPERIMENTAL INVESTIGATION OF LIQUID DIBORANE - LIQUID OXYGEN

PROPELLANT COMBINATION IN 100-POUND-THRUST ROCKET ENGINE

By William H. Rowe, Paul M. Ordin, and John M. Diehl

SUMMARY

The specific impulse of liquid diborane and liquid oxygen over a range of mixture ratios was determined in a 100-pound-thrust rocket engine operating at a combustion-chamber pressure of 300 pounds per square inch absolute.

A faired curve through the experimental data had approximately the same shape as the theoretical curve with a maximum uncorrected experimental specific impulse of 249 pound-seconds per pound at a ratio of fuel weight to total propellant weight of 0.37. When corrected for heat rejection, this value increased to 274 pound-seconds per pound, which is 92 percent of the theoretical value of 299 pound-seconds per pound based on equilibrium expansion for the fuel and the nozzle used. The maximum experimental volume specific impulse was  $182 \times 62.4$  pound-seconds per cubic foot and occurred at a ratio of fuel weight to total propellant weight of 0.25; the corrected maximum experimental value was  $199 \times 62.4$  pound-seconds per cubic foot at the same mixture ratio. These experimental values were based on a characteristic length (ratio of combustion-chamber volume to exhaust-nozzle-throat area) of 325 inches. When the characteristic length was reduced from 325 to 159 inches, a small decrease in performance occurred. No apparent change in specific impulse was observed for the two types of injection used for the experiments.

A limited number of temperature- and shock-sensitivity experiments were made with diborane. No explosions nor detonations were observed.

INTRODUCTION

Boron hydrides are of interest as rocket fuels principally because of the possibility of obtaining high specific impulse. As part of the NACA program on high-energy rocket fuels, theoretical

and experimental investigations are being conducted with diborane because it was the first boron hydride available. Theoretical calculations of diborane with several oxidants and experimental results from the operation of a 100-pound-thrust rocket engine with liquid diborane and hydrogen peroxide are presented in references 1 and 2, respectively. An investigation was conducted at the NACA Lewis laboratory from March to May 1948 to determine the performance of a 100-pound-thrust rocket engine using liquid diborane and liquid oxygen. The diborane was obtained through the cooperation of the Navy Bureau of Aeronautics. Specific impulse was measured for a range of mixture ratios with a combustion-chamber pressure of approximately 300 pounds per square inch absolute. Additional data were obtained on the effect of reducing the ratio of combustion-chamber volume to exhaust-nozzle-throat area (hereinafter designated characteristic length  $L^*$ ) by a factor of 2 and on the effect of changes in propellant injection.

In order to obtain additional information concerning the stability of diborane, a brief series of experiments was made to determine the sensitivity of diborane to temperature and shock. These supplementary data are presented in the appendix.

#### APPARATUS

A diagrammatic sketch of the apparatus is shown in figure 1. Helium pressure, controlled by two-stage regulation, was used to force the propellants into the combustion chamber. The oxygen tank was made of stainless steel and had a vacuum jacket; the diborane tank was made of a molybdenum steel. Each tank was mounted on a counterbalanced weighing beam for flow measurement. The lines from the diborane tank and the propellant valves were arranged for precooling with liquid nitrogen and dry ice, respectively. The rocket engine was mounted on a pivoted thrust stand to measure thrust and at a downward angle of  $30^\circ$  to prevent the accumulation of propellants in the combustion chamber at the start of a run. A photograph of the general setup is shown in figure 2.

#### Engine Assemblies

Cross-sectional views of the engine assemblies are shown in figure 3. The engine assemblies consisted of interchangeable injection plates, combustion chambers, and exhaust nozzles.

The injection plates were made of stainless steel and used removable injectors inserted from the inside. The injectors

were designed to produce solid streams of propellants. In injection plate A, which was used for most of the experiments, four diborane injectors and four liquid-oxygen injectors were arranged in intersecting pairs. The four diborane injectors were on an inner circle and directed diborane in streams parallel to the engine axis. The four liquid-oxygen injectors were on an outer circle and directed oxygen in streams to intersect the respective diborane streams. Injection plate B had another arrangement of injectors. Two diborane injectors and two oxygen injectors directed streams that intersected at a common point on the axis of the engine. Each injection plate had a pressure tap to obtain combustion pressure.

Two combustion chambers were used to obtain two values of characteristic length  $L^*$  (ratio of combustion-chamber volume to exhaust-nozzle-throat area) and differed essentially only in length. Both combustion chambers had an inner diameter of  $2\frac{1}{4}$  inches; chamber A had a total length of  $18\frac{1}{2}$  inches and an  $L^*$  of 325 inches; chamber B had a length of  $6\frac{3}{8}$  inches and  $L^*$  of 159 inches. Combustion chamber A was used for most of the experiments. Both chambers were machined from forged electrolytic copper, had a wall thickness of  $\frac{5}{8}$  inch, and were chrome-plated on the inner surface. Each combustion chamber was equipped with a pressure tap with a thick-wall copper connection.

The convergent-divergent nozzle was machined from forged electrolytic copper and was chrome-plated on the inside. The throat diameter was 0.549 inch, the total divergence angle was  $30^\circ$ , and the exit diameter was 1.043 inches. The nozzle was designed to obtain optimum performance for an expansion pressure ratio of 20.4 with a ratio of specific heats of the exhaust gases of 1.2.

#### Instrumentation

Propellant flow. - The oxidant and the fuel tanks were each suspended from the lever arms of counterbalances. The balances used were standard beam balances each modified to permit suspension of a propellant tank and a counterbalance tank. The counterbalance tank was a container of water that could be remotely filled or emptied as required to balance initially the propellant and the propellant tank. Dashpots were installed on the counterbalance end of the beams to dampen oscillations introduced during the runs. Unbalanced forces caused by change of weight in the

propellant systems during a run were transmitted to cantilever beams equipped with strain gages. The cantilever beam was designed for a change in deflection force of 4 pounds.

The strain gages were connected in a resistance-bridge circuit of a continuous-recording self-balancing potentiometer. In order to permit full-scale deflection of the recorder for different quantities of propellants used, resistances could be added or removed from the strain-gage circuit by switches. The potentiometer had an accuracy of 0.5 percent of full scale. Weight calibrations made before and after each run had a maximum variation of 2 percent.

Thrust. - The thrust produced by the engine was measured by means of a cantilever beam equipped with strain gages. The strain gages were connected in a resistance-bridge circuit and the unbalance in the circuit, corresponding to the thrust, was recorded on a continuous-recording, self-balancing potentiometer with an accuracy of 0.2 percent of full scale. Weight calibrations of thrust were made periodically and had a maximum variation of 0.5 percent of the total weight.

Pressure. - Combustion pressure was measured by Bourdon-tube-type pressure recorders having an accuracy of better than 1 percent of full scale. During the experiments, some difficulties were experienced with pressure-tap burnouts and clogging of the tap by the solid products of combustion. In order to insure a combustion-pressure record for every operation, two measurements of combustion pressure were made, one from a water-cooled tap in the injection plate and the other from a tap with a thick-wall copper connection in the combustion chamber. For the second measurement, a small helium bleed was provided to prevent clogging of the tap by solid combustion products. Other pressure measurements made were propellant-tank and helium-supply pressure.

Temperature. - Chromel-alumel thermocouples located in the walls of the various exhaust nozzles and combustion chambers used in the runs measured the temperature of the metal. The temperatures were recorded with an accuracy of more than 1.0 percent of their value on continuous self-balancing, strip-chart potentiometers.

Propellants. - The propellants used in the experiments were commercial liquid oxygen and liquid diborane, which contained 5 percent impurities, the impurities probably being ethane and ethyl ether.

## PROCEDURE

The rocket engine was operated by first injecting oxygen until the flow system was cold enough for oxygen to emerge as a liquid. Then diborane was injected and ignition immediately resulted. The average length of a run was 6 seconds. Immediately after the run, the diborane system was purged with helium. The first series of runs was made with an  $L^*$  of 325 inches and the eight-hole injection system (combustion chamber A and injection plate A); the second series of runs was made with an  $L^*$  of 159 inches and the eight-hole injection system (combustion chamber B and injection plate A); the third series of runs was made with an  $L^*$  of 325 inches and the four-hole injection system (combustion chamber A and injection plate B). The large  $L^*$  value was chosen for most of the runs to insure complete combustion. A combustion-chamber pressure of approximately 300 pounds per square inch absolute was maintained.

With the comparatively large  $L^*$  engines used, a considerable amount of heat was lost to the engine walls. The heat absorbed by the engine was determined by the product of the temperature rise of the copper mass, the average specific heat of the copper, and the weight of the engine. The mean temperature rise was determined after the temperature of the copper engine, as measured at several places, had reached a nearly uniform value. This temperature was reached shortly after the end of the run. The value of the temperature rise was corrected for heat loss to the atmosphere between the end of the combustion time and the time that nearly constant temperature was reached.

In order to present the performance of diborane and liquid oxygen without the penalty of high heat losses, the experimental specific-impulse values were corrected for the heat lost. As the determination of the heat loss is only approximate, the heat-loss correction was made in a simple manner by assuming that the heat loss, if available, could be converted into kinetic energy by the nozzle at the ideal cycle efficiency  $\eta$ . Thus

$$I \text{ (corrected)} = \sqrt{I^2 \text{ (experimental)} + 48.37 Q\eta}$$

where

$I$  specific impulse, lb-sec/lb

$Q$  heat loss, Btu/lb

$\eta$   $1 - T_e/T_c$

$T_e$  exit temperature,  $^{\circ}\text{K}$  (reference 1)

$T_c$  combustion temperature,  $^{\circ}\text{K}$  (reference 1)

Pressure corrections were made by determining from theoretical data the effect on performance of small deviations in combustion pressure from the design value of 300 pounds per square inch absolute. In the pressure region of 300 pounds per square inch absolute a 1-pound-per-square-inch change in pressure from the design value results in a change in specific impulse of approximately 0.106 pound-second per pound. For combustion pressures of approximately  $300 \pm 15$  pounds per square inch absolute, the maximum pressure correction of the specific-impulse value is less than 1 percent.

It is desirable to compare experimental performance with theoretically obtained values. Theoretical values of specific impulse are usually determined for such ideal conditions as pure compounds for propellants, parallel flow of exhaust gases in nozzles, equilibrium composition or frozen composition expansion, isentropic expansion, and no effect of the jet on external pressure. None of these ideal conditions exist in the actual case. Estimation of some of the more obvious deviations between the assumed and actual conditions, however, is possible. The diborane used for the experimental investigation consisted of approximately 95-percent diborane with the remainder probably ethane and ethyl ether. The theoretical performance of pure diborane with liquid oxygen is reported in reference 1. The theoretical performance of ethane and ethyl ether with liquid oxygen was unavailable. In order to correct the theoretical specific impulse of the fuel used, however, the impurity was considered to be propane, a related hydrocarbon, for which theoretical performance calculations were available. If it is assumed that the fuel used was 95-percent diborane and 5-percent propane, the theoretical specific impulse was estimated as 2 percent lower than the performance of pure diborane with liquid oxygen. The correction for the deviation of the flow from the assumed axial direction through the exhaust nozzle reduces the theoretical performance by approximately 2 percent (reference 3). These two factors would therefore reduce the theoretical values of specific impulse by about 4 percent.

For the purpose of determining the volume specific impulse, the density for diborane was chosen from the expression (reference 4, p. 559)

$$d = 0.3140 - 0.001296t \text{ } ^{\circ}\text{C}$$

using the temperature of a mixture of dry ice and alcohol ( $-72^{\circ}$  C) (reference 5, p. 1764), which approximately corresponded to the experimental conditions. The density of liquid oxygen was obtained from reference 5. Values of characteristic velocity and thrust coefficient were obtained from the results of the experimental data using the equations

$$C^* = P_c A_t g / W$$

and

$$C_F = T / P_c A_t$$

where

$C^*$  characteristic velocity

$P_c$  combustion-chamber pressure, (lb/sq in. absolute)

$A_t$  exhaust-nozzle-throat area, (sq in.)

$g$  gravitational constant, (ft/sec<sup>2</sup>)

$W$  total propellant flow, (lb/sec)

$C_F$  thrust coefficient

$T$  thrust, (lb)

These two parameters are frequently used to evaluate rocket performance.

## RESULTS AND DISCUSSION

Typical experimental data obtained during the experiments are shown in figure 4. Records of the thrust and the combustion-chamber pressure showed that combustion was stabilized between the first and second seconds of operation, after which time there was very little deviation in the values of thrust and combustion-chamber pressure. Figure 5 presents the experimental specific impulse plotted against the ratio of fuel weight to total propellant weight. Only runs that were steady in operation and free of engine failures are presented. A curve is drawn through the points that were obtained with the engine having an  $I^*$  of 325 inches and an eight-hole injection system. Also shown in figure 5 is one specific-impulse value for this engine operating at a combustion pressure of 343 pounds per square inch absolute. Other data taken with an engine having a smaller  $I^*$  and with one having a different



method of injection are also shown. The experimental performance data cover a range of ratios of fuel weight to total propellant weight of 0.22 to 0.58 (stoichiometric, 0.224). The maximum specific impulse, as indicated by the faired curve, is 249 pound-seconds per pound and occurred at a ratio of fuel weight to total propellant weight of approximately 0.37.

A curve obtained by correcting the experimental data for heat losses and for small combustion-chamber-pressure differences from 300 pounds per square inch is also shown in figure 5. The corrections are predominantly heat corrections. The curve with these corrections increased to a maximum of 274 pound-seconds per pound at a ratio of fuel weight to total propellant weight of about 0.36.

For comparison, the theoretical performance for the fuel and the expansion nozzle used is shown in figure 5; chemical equilibrium during expansion is assumed. Figure 5 also shows the theoretical performance curve of 100-percent liquid diborane and liquid oxygen taken from reference 1.

The shapes of the experimental and theoretical curves are similar with the peak occurring in nearly the same position near a ratio of fuel weight to total propellant weight of 0.36. The maximum uncorrected experimental specific impulse is approximately 83 percent of the theoretical value for the fuel and nozzle used. The peak value of the corrected experimental curve is 92 percent of the peak (299 lb-sec/lb) for the theoretical curve for equilibrium expansion and the fuel and the nozzle used.

Changing the  $L^*$  of the engine from 325 to 159 inches produced a small decrease in performance (fig. 5). Changing the method of injection from the eight-hole, solid-jet system to the four-hole system in an engine having an  $L^*$  of 325 inches appeared to have no definite effect on the average performance of the propellant.

The injection systems and the combustion volumes used were not sufficient in number and variation to determine optimum values of these design variables.

Curves of theoretical and experimental volume specific impulse plotted against ratio of fuel weight to total propellant weight are presented in figure 6. The values of theoretical volume specific impulse were obtained by multiplying values of theoretical specific impulse by the density of the propellant combination at corresponding propellant mixture ratios.

In the same manner, the values of experimental volume specific impulse were obtained from the values of experimental specific impulse. The maximum value for the experimental volume specific impulse as indicated by the faired curve is approximately  $182 \times 62.4$  pound-seconds per cubic foot and occurs at a ratio of fuel weight to total propellant weight of about 0.25. The maximum corrected value of volume specific impulse of  $199 \times 62.4$  pound-seconds per cubic foot is approximately 92 percent of the maximum theoretical value of  $217 \times 62.4$  pound-seconds per cubic foot, which occurs at a mixture ratio of 0.22 and is calculated for the fuel and the expansion nozzle used.

A summary of the experimental results is presented in table I, which includes specific impulse, specific impulse corrected, volume specific impulse, characteristic velocity, and thrust coefficient. These results show a considerable variation of characteristic velocity and thrust coefficient under comparable conditions for these experiments.

An investigation of the accuracy of the data showed that there are three possible sources of error: in the calibration of the weighing or thrust systems, in the recording instruments used for recording the data, and in the interpretation of the data records. The instrument errors have been previously described. For data interpretation, a variation of 0.5 percent could be made in reading the thrust records and 1.0 percent could be made in reading the flow records. The maximum instrument variation and the variations interpreting data permit a maximum possible variation of 4.0 percent in specific impulse.

During operation of the engine, a deposit accumulated over the entire inner surface of the engine. Photographs of typical deposits are shown in figure 7. Generally this deposit was approximately  $1/32$  inch thick from the rear of the chamber (including the surfaces of the injector nozzles) to the convergent section of the exhaust nozzle where it increased slightly. Along the convergent section to the throat of the exhaust nozzle, the deposit generally thinned to about  $1/64$  inch. The radial distribution of the deposit at the throat was nonuniform. The throat deposit is probably a result of afterburning of diborane during the purging operation rather than of combustion during operation. The deposit was crusty in nature, usually with a smooth, glazed, dark-gray to dark-brown surface. Some difficulties were experienced in the investigation because the high heat release caused several severe burnouts of the exhaust nozzle, the injector nozzles, and the injector head. Typical injector-plate and exhaust-nozzle failures are shown in figure 8.

## SUMMARY OF RESULTS

Experiments were conducted to determine the performance of a 100-pound-thrust rocket engine at a combustion-chamber pressure of 300 pounds per square inch absolute using liquid diborane and liquid oxygen as propellants. The engine used for most of the experiments had an injection system of four pairs of intersecting jets and a ratio of combustion-chamber volume to exhaust-nozzle-throat area of 325 inches. The experiments produced the following results:

1. The shape of the experimental specific-impulse curve was similar to that of the theoretical curve. Both curves reached a maximum near a ratio of fuel weight to total propellant weight of 0.36. The maximum uncorrected experimental specific impulse, as indicated by a faired curve through the data, was 249 pound-seconds per pound or approximately 83 percent of the theoretical value for equilibrium expansion and the fuel and the nozzle used.

2. When corrections for heat loss to the engine walls and small deviations of combustion-chamber pressure were applied to the experimental data, the maximum performance value was about 274 pound-seconds per pound or 92 percent of the theoretical value for equilibrium expansion and the fuel and the nozzle used.

3. The maximum uncorrected experimental volume specific impulse was  $182 \times 62.4$  pound-seconds per cubic foot and the corresponding value when corrected for heat loss and pressure deviations was  $199 \times 62.4$  pound-seconds per cubic foot. The maximum volume specific impulse occurred near a ratio of fuel weight to total propellant weight of 0.25. The theoretical curve had a maximum value of  $217 \times 62.4$  pound-seconds per cubic foot at a mixture ratio of 0.22 for the fuel and the nozzle used.

4. When the injection system was changed from the eight-hole, solid jet system to the four-hole system, there was no apparent change in specific impulse. When the characteristic length was changed from 325 to 159 inches (using the eight-hole system), there was a small decrease in performance. The study of the effects of the injection system and combustion volume were not sufficiently extensive to determine optimum configurations. Several experiments made to determine the sensitivity of diborane to temperature and to detonation produced no explosions nor detonations.

National Advisory Committee for Aeronautics,  
Lewis Flight Propulsion Laboratory,  
Cleveland, Ohio.

## APPENDIX - SENSITIVITY OF DIBORANE TO TEMPERATURE AND SHOCK

For the purpose of establishing a safe handling procedure for diborane, the sensitivity of diborane to temperature and to the shock produced by the detonation of a number 6 detonator cap was determined.

A schematic diagram of the equipment for determining the temperature sensitivity of diborane is shown in figure 9(a). A stainless-steel bomb, 1 inch in diameter and  $4\frac{1}{2}$  inches in length, fitted with a Teflon-packed needle valve and stainless-steel safety disk tested to a bursting pressure of 3700 pounds per square inch, contained the diborane as a gas. Asbestos-covered resistance wire was wrapped around the container and the temperature was measured by means of two thermocouples placed on the cylinder. In addition, the pressure increase during the heating was observed by means of a steel Bourdon-tube pressure gage. The temperature-sensitivity apparatus was filled with gaseous diborane and heated to approximately  $1000^{\circ}$  F over a period of about  $1/2$  hour.

For the three temperature-sensitivity determinations made, the only reaction observed was a gradual pressure increase from 60 pounds per square inch gage at dry-ice temperature to 280 pounds per square inch gage at approximately  $1000^{\circ}$  F, with the pressure remaining constant at any intermediate temperature for a few minutes. These experiments indicate no explosions resulted from gradual application of heat.

The sketch of the detonation experimental apparatus is shown in figure 9(b). Two brass containers having volumes of 30 and 60 cubic centimeters were used to hold the diborane. A thin brass separating tube for containing the detonator cap was centrally located in the diborane container.

Prior to the experiments with diborane, preliminary detonation work was performed with the detonator cap alone, and with the cap and water, methyl alcohol, and a mixture of 80-percent tetra-nitromethane and 20-percent nitrobenzene. For the investigation of diborane, two experiments were made with gaseous diborane in the 30-cubic-centimeter container; one experiment was made with 13.1 grams of liquid diborane (at a temperature of approximately  $-72^{\circ}$  C) in the 30-cubic-centimeter container and one experiment was made with 24.6 grams of liquid diborane (at a temperature of approximately  $-72^{\circ}$  C) in a 60-cubic-centimeter container. In the preliminary detonation work, the results obtained with the detonator cap alone and with water and methyl alcohol were all similar

in that the small tube containing the cap blew apart, resulting in a slight bulging of the large brass container. In each experiment with the tetranitromethane and nitrobenzene mixture, which is known to be sensitive to the shock produced by a number 6 cap, the entire assembly disintegrated with the explosion of the cap. The results of the shock tests with gaseous and liquid diborane were similar to those obtained with the cap alone or with the cap and water or with the cap and alcohol.

With the limited number of sensitivity determinations made with diborane, no explosions nor detonations were produced by heat or by shock.

#### REFERENCES

1. Huff, Vearl N., Calvert, Clyde S., and Erdmann, Virginia C.: Theoretical Performance of Diborane as a Rocket Fuel. NACA RM No. E8I17a, 1949.
2. Rowe, William H., Ordin, Paul M., and Diehl, John M.: Investigation of the Diborane - Hydrogen Peroxide Propellant Combination. NACA RM No. E7K07, 1948.
3. Malina, Frank J.: Characteristics of the Rocket Motor Unit Based on the Theory of Perfect Gases. Jour. Franklin Inst., vol. 230, no. 4, Oct. 1940, pp. 433-454.
4. Laubengayer, A. W., Ferguson, R. P., and Newkirk, A. E.: The Densities, Surface Tensions and Parachors of Diborane, Boron Triethyl and Boron Tribromide: The Atomic Parachor of Boron. Jour. Am. Chem. Soc., vol. 63, no. 2, Feb. 1941, pp. 559-561.
5. Anon.: Handbook of Chemistry and Physics. Charles D. Hodgman, ed., Chem. Rubber Pub. Co. (Cleveland), 29th ed., 1945, pp. 425, 1764.

TABLE I - SUMMARY OF PERFORMANCE OF LIQUID DIBORANE AND LIQUID OXYGEN IN

## ROCKET ENGINE

Chamber pressure (lb/sq in. abs.)	Thrust (lb)	Total propellant flow (lb/sec)	Specific impulse, I (lb-sec/lb)	Ratio of fuel weight to total propellant weight	Characteristic length, L* (in.)	Specific impulse, corrected (lb-sec/lb)	Volume specific impulse $\left(\frac{\text{lb-sec}}{\text{cu ft}} \times \frac{1}{62.4}\right)$	Characteristic velocity, C* (ft/sec)	Thrust coefficient C <sub>F</sub>
Injection system, eight hole									
315	88.9	0.402	221	0.581	325	223	123	5960	1.20
343	105.0	.425	247	.267	325	261	190	6120	1.30
315	89.2	.360	248	.349	325	280	174	6660	1.20
290	88.0	.359	245	.329	325	272	175	6150	1.28
295	85.3	.346	247	.391	325	287	171	6480	1.22
285	96.1	.387	248	.401	325	266	164	5610	1.43
290	95.5	.438	218	.219	325	240	178	5040	1.39
297	99.8	.435	229	.253	325	247	179	5200	1.42
305	101.6	.417	244	.414	325	258	159	5560	1.41
310	104.2	.422	247	.388	325	262	166	5580	1.42
285	96.1	.416	232	.392	159	251	150	5220	1.42
295	97.0	.411	244	.408	159	259	155	5470	1.39
295	95.4	.408	234	.372	159	237	155	5510	1.37
Injection system, four hole									
290	97.2	0.389	250	0.350	325	273	170	5680	1.42
290	95.4	.367	260	.400	325	274	167	6020	1.39
305	99.5	.415	240	.367	325	259	160	5600	1.38



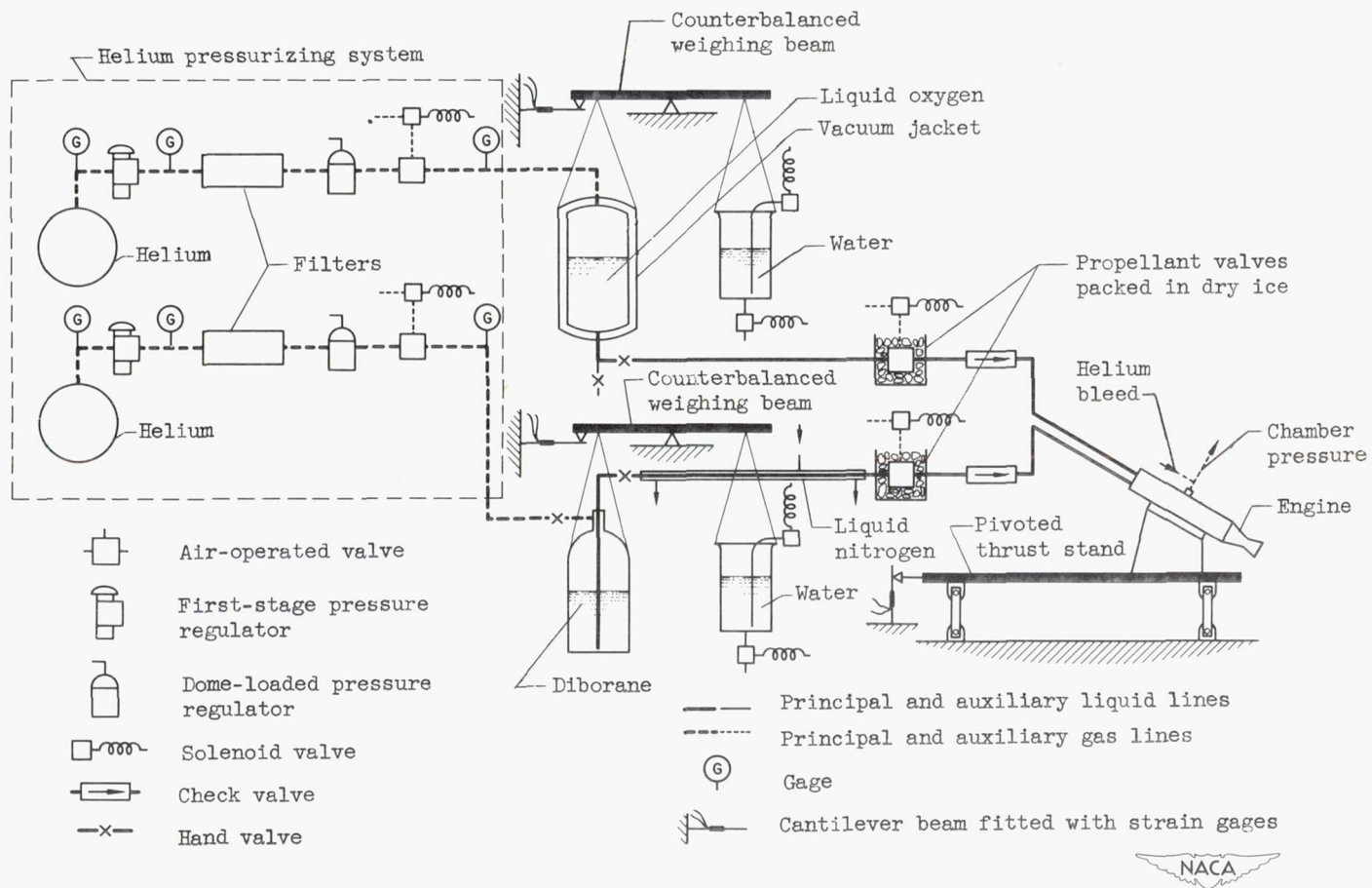

Figure 1. - Diagrammatic sketch of 100-pound-thrust rocket apparatus for liquid diborane and liquid oxygen.

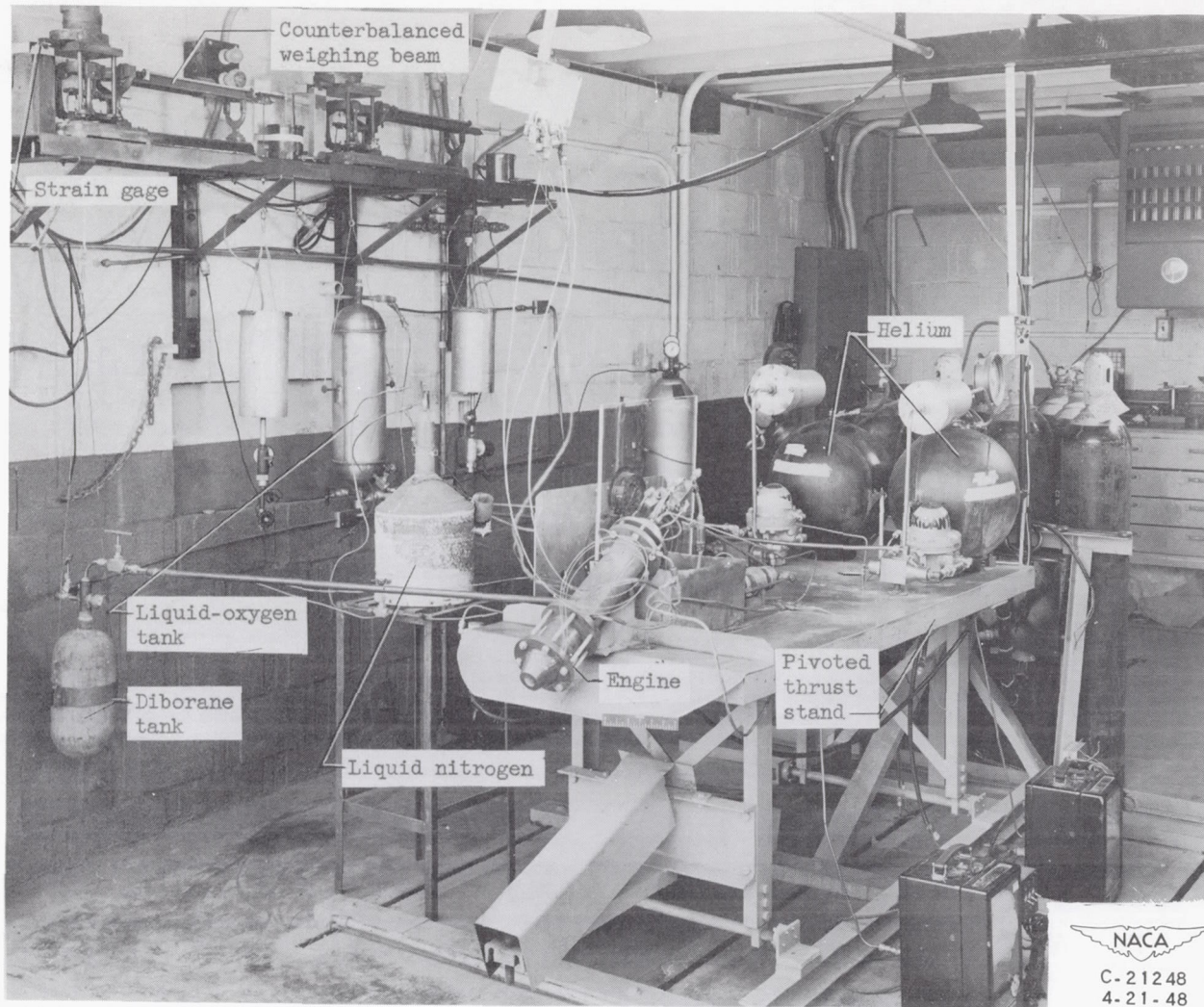
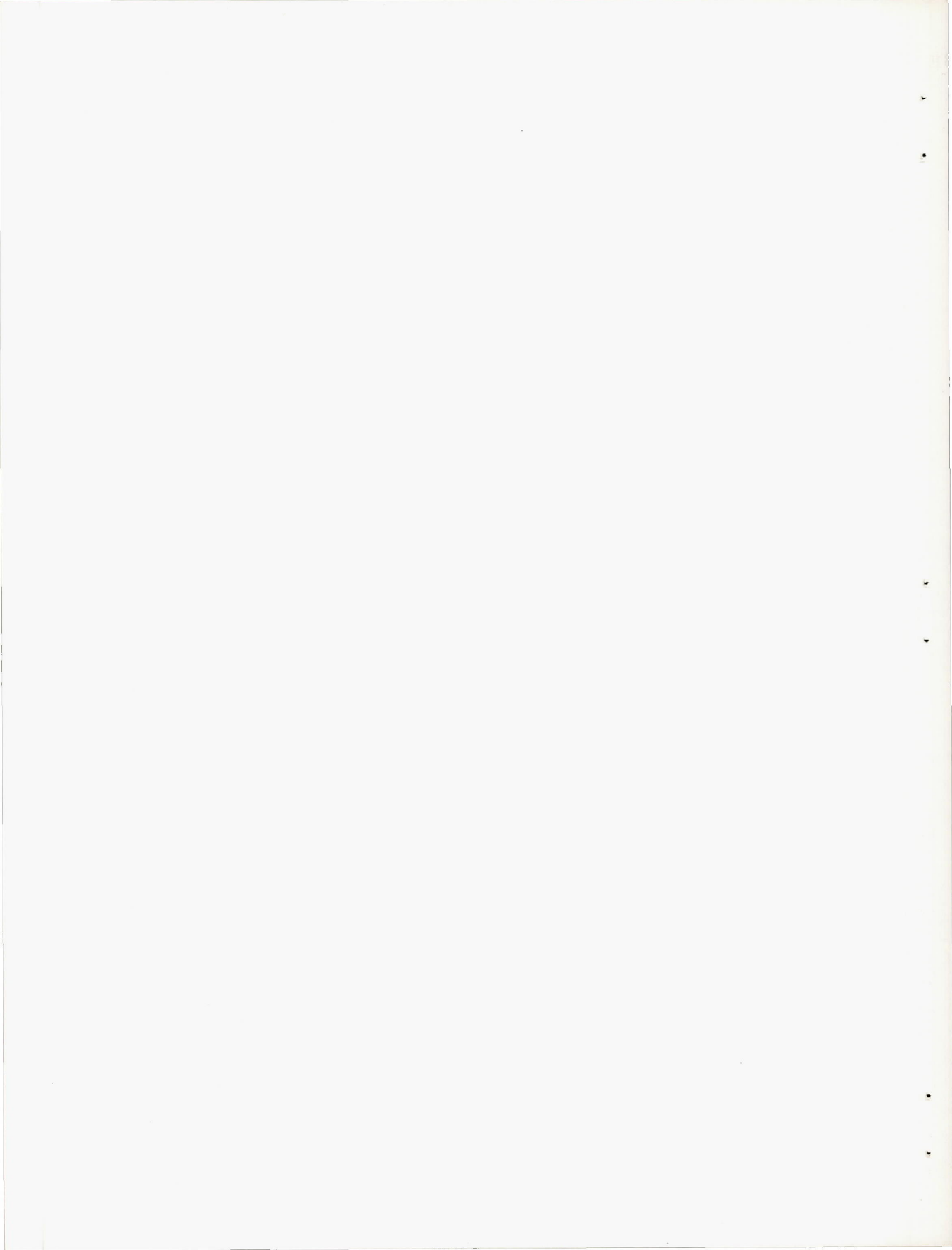

Figure 2. - Rocket engine and auxiliary equipment.





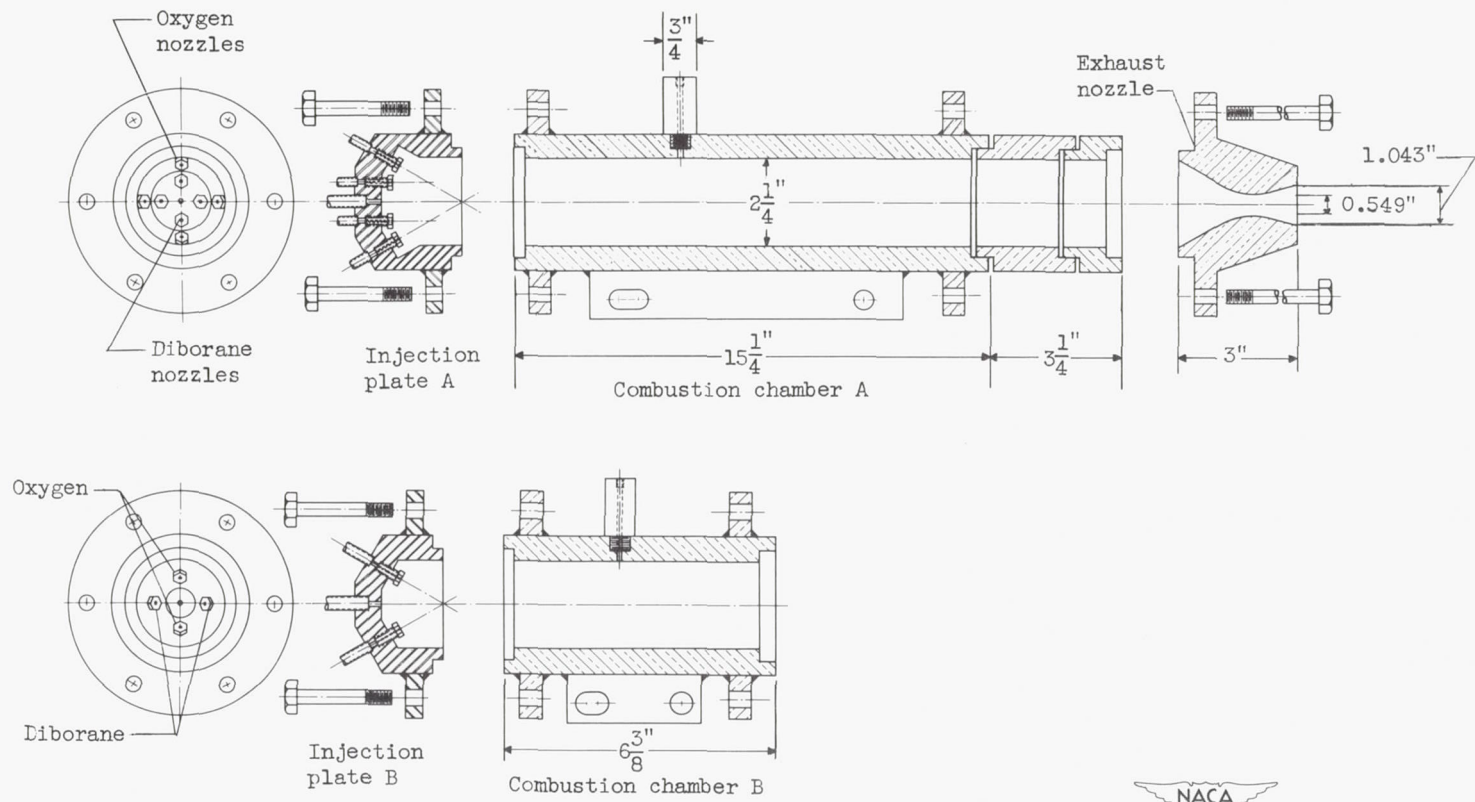
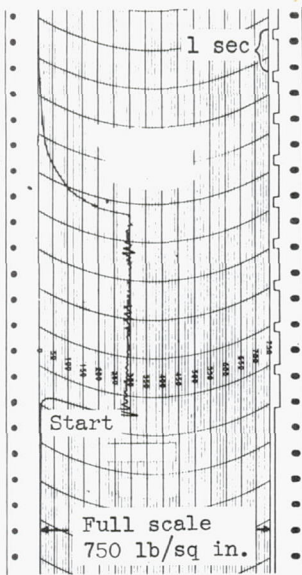
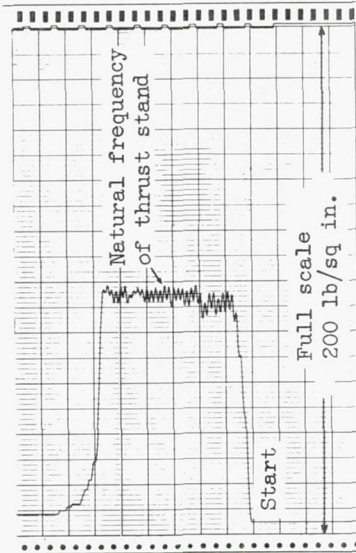

Figure 3. - Interchangeable rocket-engine assemblies.



Combustion-chamber pressure



Thrust

Values from records

Thrust, (lb)	104
Diborane flow, (lb/sec)	0.164
Oxygen flow, (lb/sec)	0.258
Fuel, (percent by weight)	38.8
Specific impulse (83.3 percent theoretical), (lb-sec/lb)	247.3
Combustion pressure, (lb/sq in. gage)	285-300

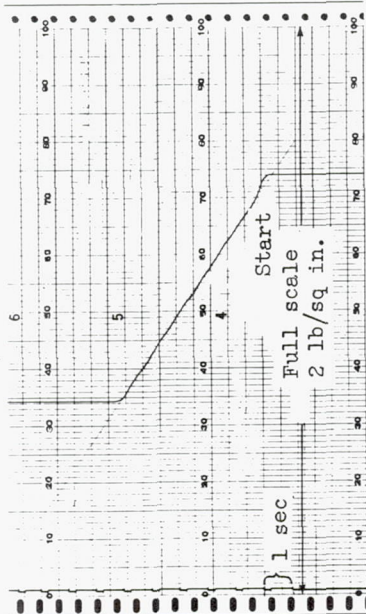

Diborane flow

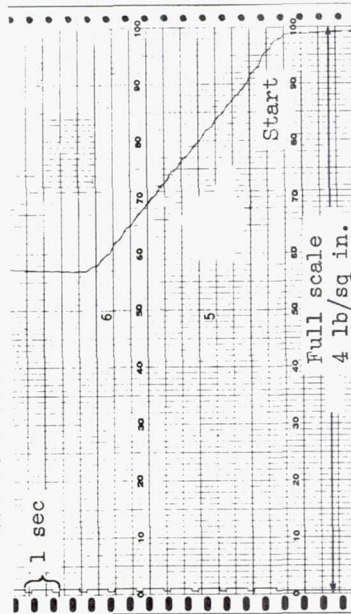

Oxygen flow

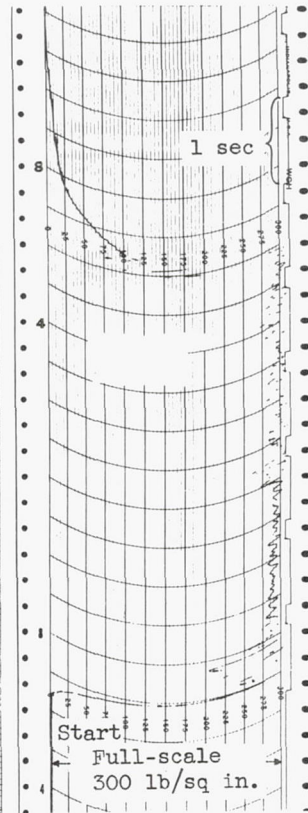

Combustion-chamber pressure



Figure 4. - Typical data obtained during experiments.

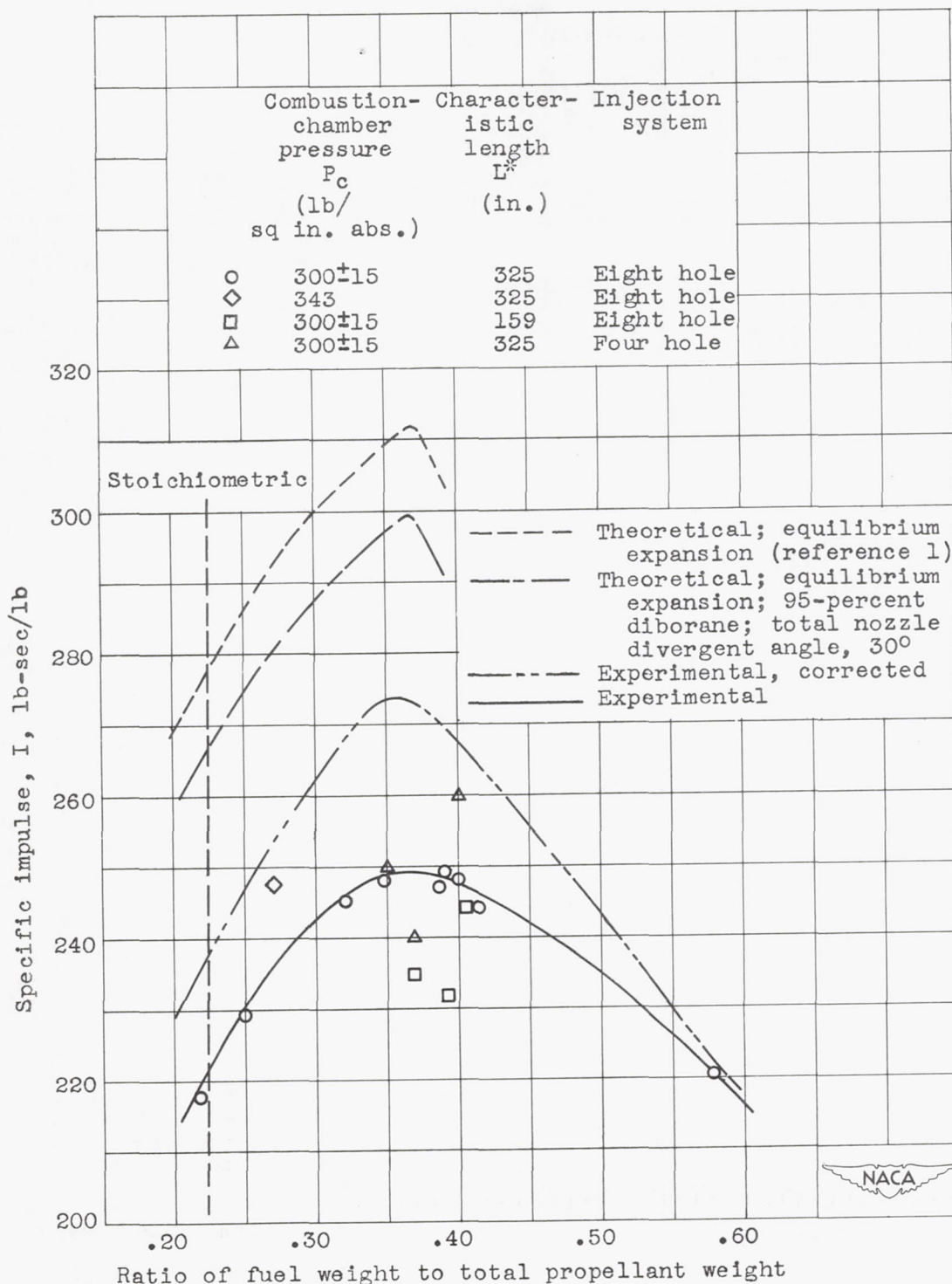

Figure 5. - Theoretical and experimental specific impulse of 100-pound-thrust rocket engine using liquid diborane and liquid oxygen.

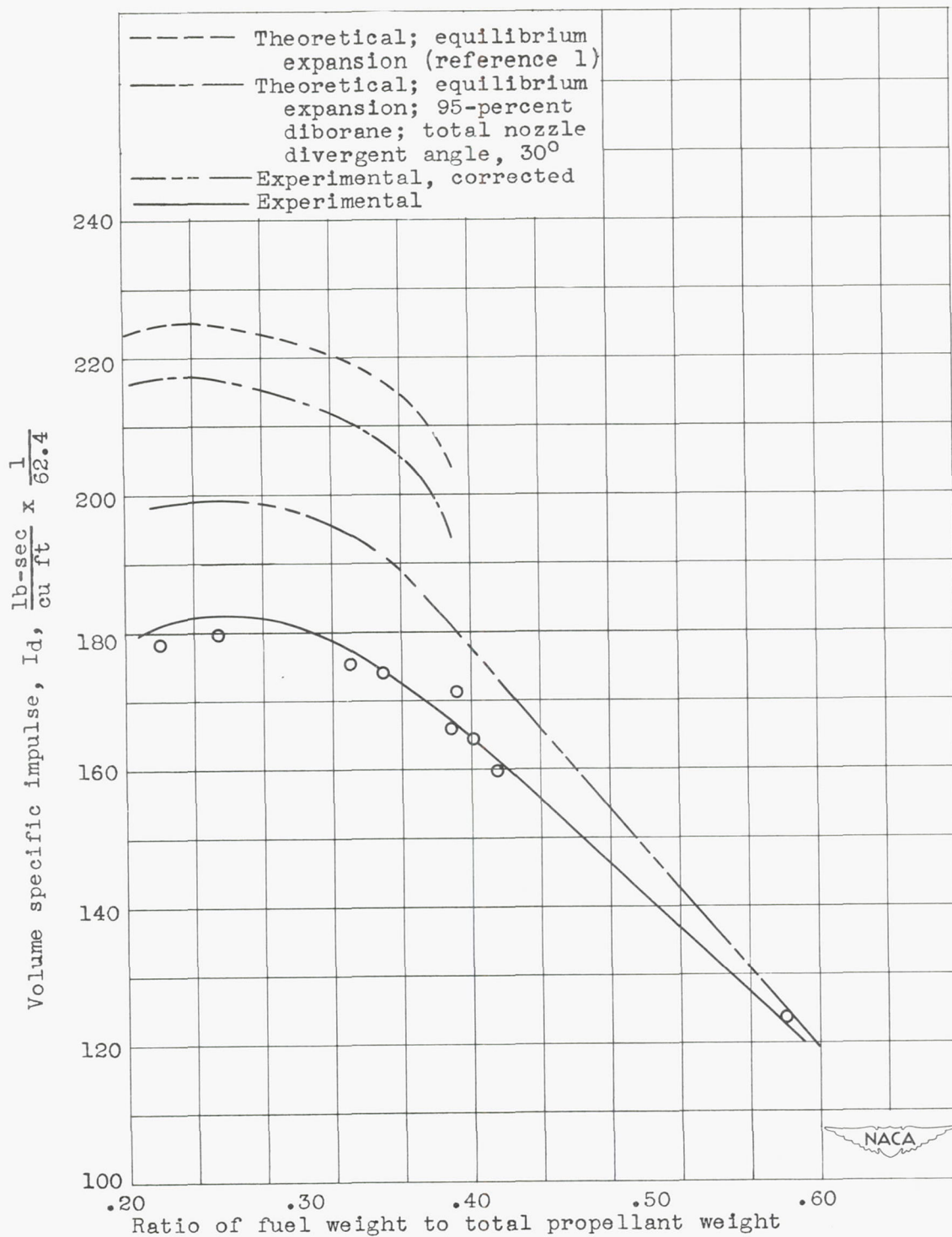
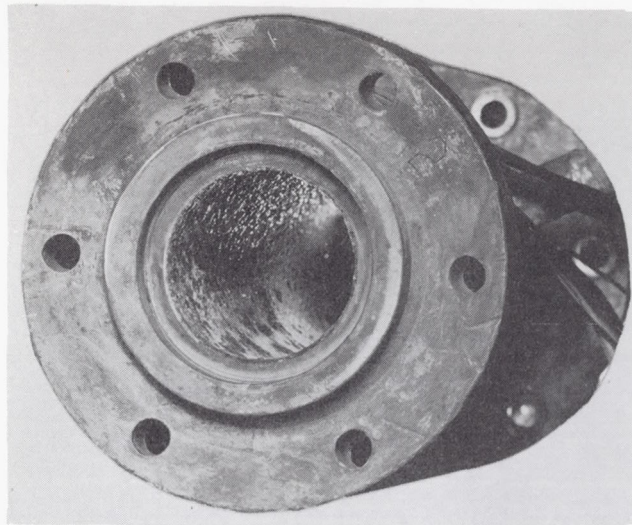
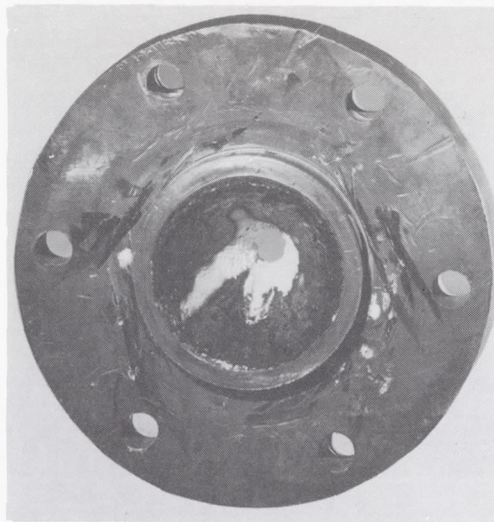

Figure 6. - Theoretical and experimental volume specific impulse in 100-pound-thrust rocket engine using liquid diborane and liquid oxygen.



(a) Engine chamber, downstream.

NACA  
C-21505  
5-20-48



(b) Exhaust nozzle, upstream.

NACA  
C-21676  
6-10-48

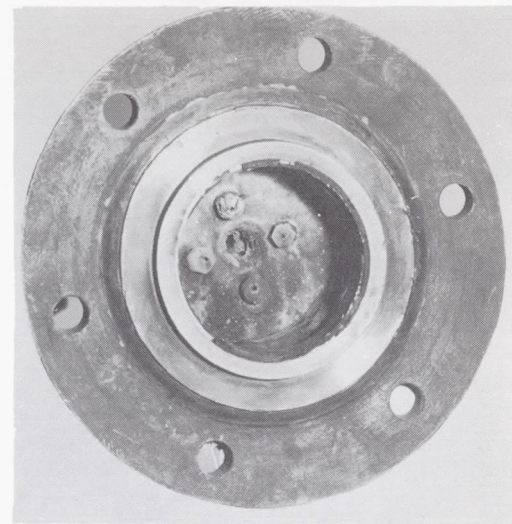

(c) Injection head and nozzle.

NACA  
C-21679  
6-10-48

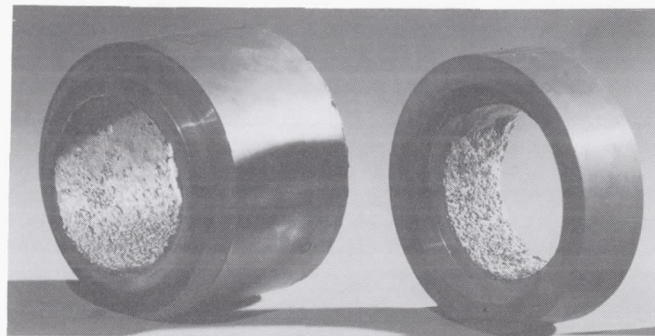

(d) Spacer.

NACA  
C-21678  
6-10-48

Figure 7. - Deposits on inner walls of rocket engine.

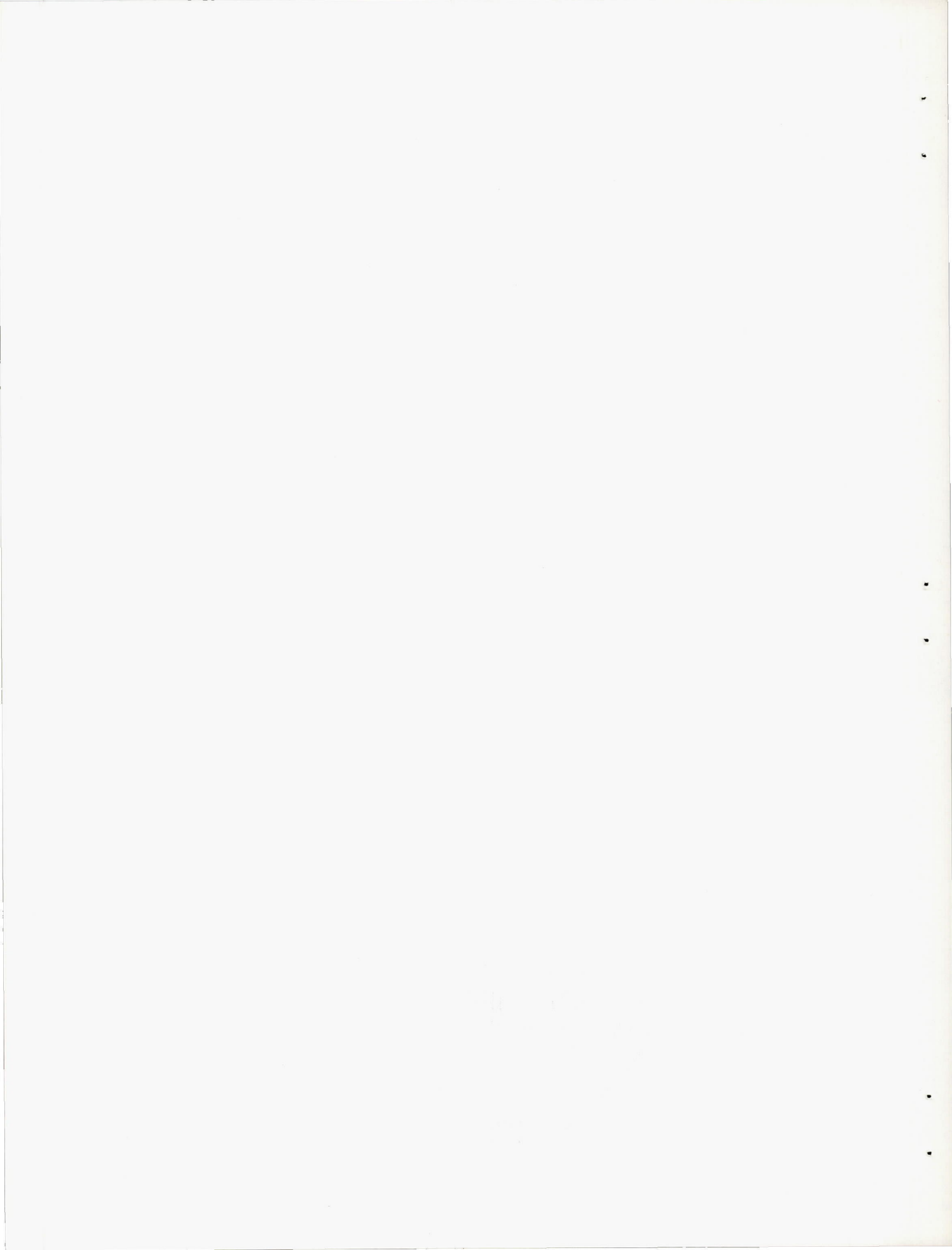

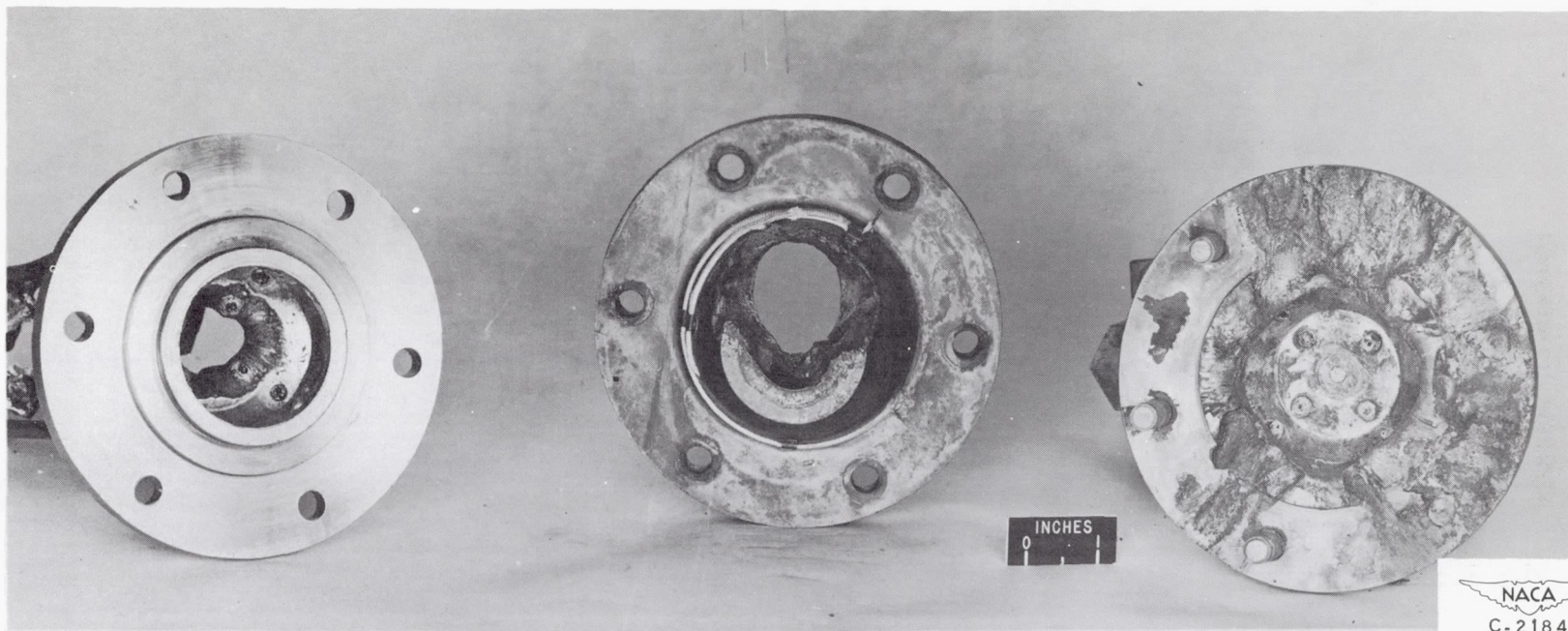

(a) Injector plate

(b) Exhaust nozzle

(c) Injector plate

Figure 8. - Typical burned-out exhaust nozzle and injector plates.



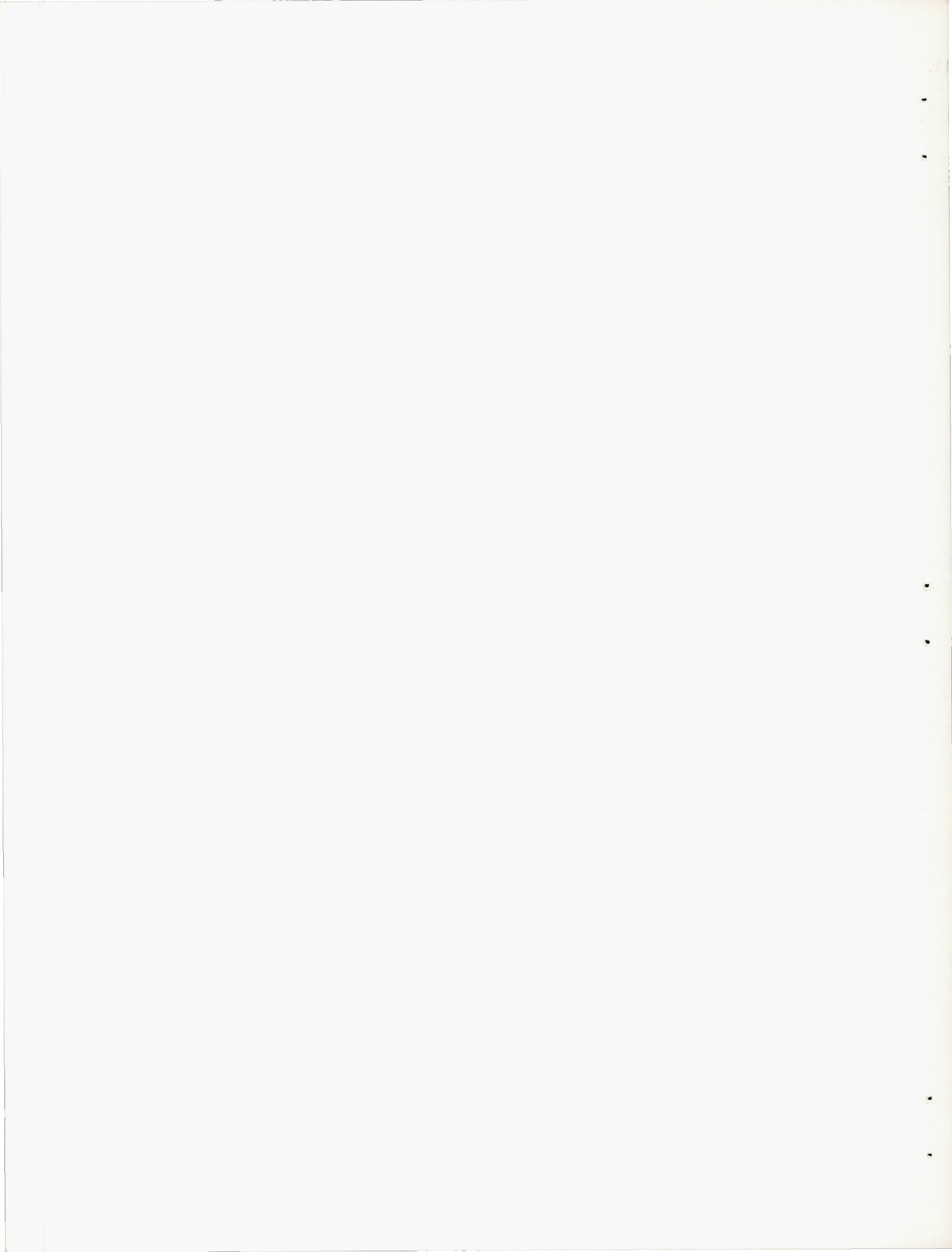

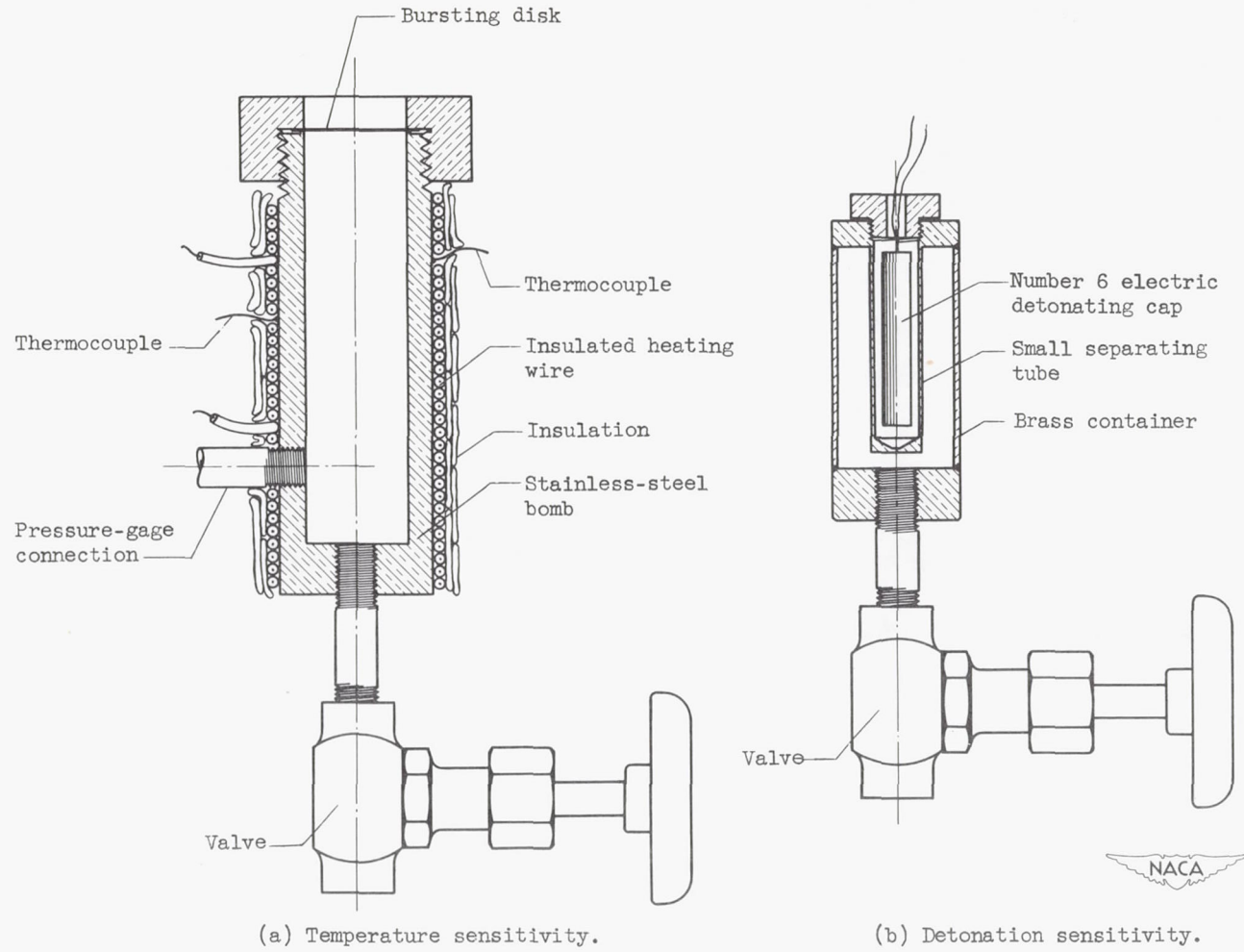

Figure 9. - Sensitivity apparatus.

