

# RESEARCH MEMORANDUM

FACTORS IN SELECTING FUELS FOR GAS-TURBINE POWERED AIRCRAFT

By Louis C. Gibbons

Lewis Flight Propulsion Laboratory  
Cleveland, Ohio

NATIONAL ADVISORY COMMITTEE  
FOR AERONAUTICS

WASHINGTON  
November 13, 1950

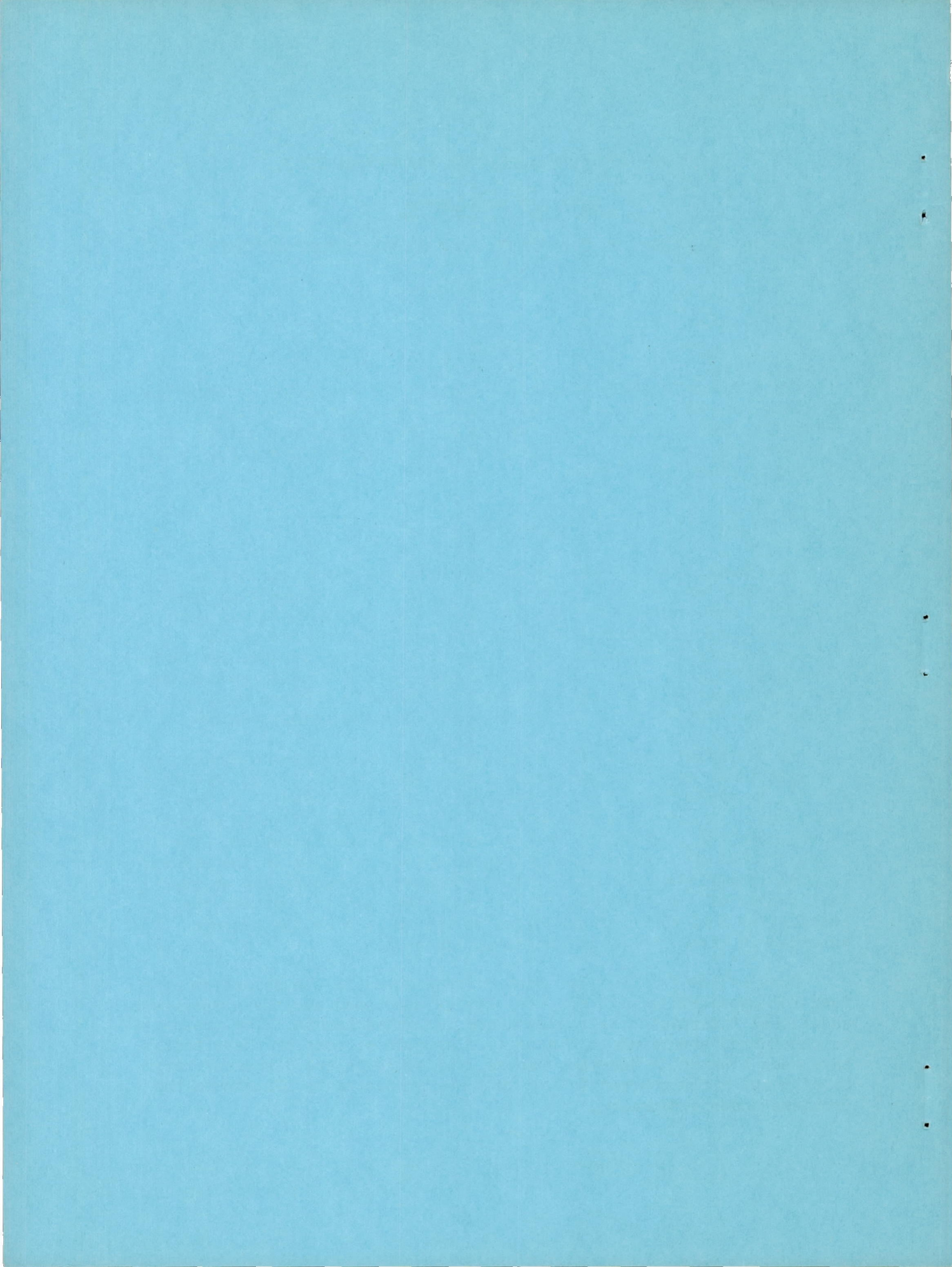

## NATIONAL ADVISORY COMMITTEE FOR AERONAUTICS

RESEARCH MEMORANDUM

## FACTORS IN SELECTING FUELS FOR GAS-TURBINE POWERED AIRCRAFT

By Louis C. Gibbons

## SUMMARY

This report briefly summarizes some of the available information on fuels for gas-turbine powered aircraft. The effects of fuel volatility and composition on the range, reliability, and safety of aircraft are discussed. Availability is briefly considered for fuels at various volatility levels.

## INTRODUCTION

The development of gas-turbine engines and their application to aircraft has been a very rapidly changing process. Along with the mechanical development of aircraft gas-turbine engines, it has been necessary to acquire a knowledge of the fuel requirements of the engines and the requirements and limitations of fuel systems for high-speed aircraft. It has also been necessary to continually revise the estimated quantities of jet fuel required for an air force with a constantly changing ratio of gas-turbine to reciprocating engines.

As the requirements of the jet fuel have become more apparent, the specifications have been changed from AN-F-32 (JP-1), to AN-F-34 (JP-2), to AN-F-58 (JP-3), to AN-F-58a, and to MIL-F-5624. As new knowledge of aircraft requirements becomes available, it will probably be necessary to continue to revise the jet-fuel specification. The establishment of a specification requires consideration of the effects of fuel composition and volatility on engine performance and on the fuel system of the airplane. It is also necessary to consider the quantity of fuel required and other variables such as the hazards entailed in transporting and handling the fuel.

Some of the factors that must be considered in the selection of a fuel for gas-turbine aircraft are briefly discussed and the areas where additional information is required are indicated herein. The topics to be considered are given in figure 1. Inasmuch as some of these topics have been treated in numerous papers, the subjects are discussed very briefly and a few representative data are presented to illustrate the problems under discussion.

A report of this type is necessarily of a transient nature because new information on the mutual compatibility of fuels and aircraft is being made available very rapidly by many investigators. This report summarizes some of the data available in July, 1950.

#### FUEL AVAILABILITY

The selection of a fuel for gas-turbine powered engines must be based on the requirements of the engine, the aircraft fuel system, and the logistics of possible future operations. After the desired properties of a fuel are determined on the basis of these criteria, an estimate must be made as to the quantity of fuel required for an air force in time of emergency. After the desired properties of the fuel and the quantity required are known, the next step is to study the various products derived from crude oil by present refinery methods and to determine whether enough fuel of the desired properties can be obtained. In this approach to the problem, it is necessary to consider all the essential requirements for gasoline, kerosene, fuel oils, and diesel oils. Examples of such uses include fuel for automotive equipment, trucks, tanks, ships, diesel locomotives, industrial fuels, and essential civilian uses.

The estimation of the fuel requirements for all essential uses is obviously not within the scope of the present discussion, but presumably the requirements are being established by the appropriate agencies. For purposes of illustration, a hypothetical requirement of 1,000,000 barrels per day of jet fuel is chosen. This quantity of fuel would operate 13,480, 5000-pound-thrust turbojet engines 4 hours per day, assuming a specific fuel consumption of 1 pound of fuel per pound of thrust per hour. The 600,000 barrels per day of aviation gasoline used at the end of World War II allowed the operation of 37,500, 2000-horsepower reciprocating engines 4 hours a day, assuming a specific fuel consumption of 0.5 pound per horsepower-hour.

After a requirement of 1,000,000 barrels per day is established, the quantities and types of product derived from petroleum are considered in order to determine whether there can be some choice of the type of fuel selected. Figure 2 shows the relative quantities of materials obtained from a barrel of crude oil: 45 percent is converted by distillation and cracking methods into gasoline; 5 percent into kerosene; 18 percent into distillate fuels including fuel oils and diesel oil; 19 percent into residual fuels for industrial boilers, ships, etc.; 3 percent into lubricants; and 10 percent into gases, losses, and special products.

1421

1421

If the refinery processing capacity is 6,700,000 barrels of crude oil per day (reference 1), the postulated requirement of 1,000,000 barrels would be 15 percent of the total production. Figure 2 shows that this 15 percent could be removed entirely from the gasoline fraction and leave 30 percent of the crude oil as gasoline for all other uses, including that needed for military aircraft powered by reciprocating engines. Another possibility would be to take 2 percent of the total crude oil from the gasoline barrel, 5 percent from kerosene, and 8 percent from the distillate fuels to yield 15 percent of the crude oil. A third possibility would be to use gasoline fractions boiling above 200° F to the extent of 12 percent of the total crude oil and add a total of 3 percent from the kerosene and distillate fuels to give a total of 15 percent for jet fuel. Actually the requirements of an aircraft fuel such as low freezing point, satisfactory performance in engines, and many other considerations tend to restrict the number of possible combinations that can be chosen. Some of these considerations will be discussed in the subsequent sections.

A fourth possible combination of components would give JP-3 (AN-F-58) type fuel, now specified MIL-F-5624, which was chosen originally on the basis of the maximum quantity of fuel that would meet a freezing point of -76° F and a corrosion limit. As indicated in figure 2, such a fuel includes all the gasoline, all the kerosene, and some of the distillate fuels, giving a total of 50 to 55 percent of the crude oil that could be converted into a jet fuel. If 1,000,000 barrels per day were required, then 12 percent of the crude oil could be withheld from gasoline, 1.5 percent from kerosene and 1.5 percent from distillate fuels to make the total of 15 percent required for gas-turbine aircraft.

In addition to the other restrictions on the selection of possible components for an aircraft turbine fuel, refinery facilities must also be considered. In order to provide maximum quantities of a fuel containing the higher boiling components from gasoline, it would be necessary to install additional distillation equipment in the present refineries, whereas JP-3 fuel could be produced in maximum quantities with the existing refinery equipment.

For the preceding discussion, it must be emphasized that the assumption of 1,000,000 barrels per day required for turbojet fuel is purely a hypothetical case and is selected only for purposes of illustration.

In summary of the availability problem, it seems that there might be some choice as to the physical properties of an aircraft turbine fuel. The possible choices will be limited by the quantity of fuel required and by the aircraft requirements.

## AIRCRAFT RANGE

## Heat Energy of the Fuel

Many high-speed aircraft have limited storage space for fuel. If a fuel could be made available that would deliver the maximum heat energy per gallon, it would extend the flight range of so-called "volume-limited" aircraft. Unfortunately, those fuels that burn to give a high heat release per gallon also have a high specific gravity, so that a tank of such a fuel weighs more than aviation gasoline and gives a higher take-off weight and a higher drag in flight than gasoline. The trends to be observed with hydrocarbon fuels are shown in figure 3. Heats of combustion in terms of Btu per pound and Btu per gallon are plotted as functions of specific gravity. The specific gravity of petroleum derivatives is a function of volatility. The specific gravity increases so that the high boiling fuels tend to give higher Btu per gallon and lower Btu per pound than gasoline-type fuels. Although mixed fuels give some scatter around the lines, the trends clearly indicate that a fuel with a high Btu per gallon has a low Btu per pound and vice versa, so that fuels derived from petroleum will not give high heat releases per unit volume unless some sacrifices are made on Btu per pound. An aviation gasoline, an AN-F-58 fuel (JP-3), a 1-pound R.V.P. fuel, and an AN-F-32 fuel (JP-1) are shown. The physical properties of three of the fuels are given in table I, and distillation curves are shown in figure 4.

## Vapor and Surging Losses

Another factor in the consideration of the flight range of aircraft is the possibility of the loss of fuel by boiling as the aircraft climbs to high altitudes. Fuel in an aircraft tank will start to boil when the airplane climbs to an altitude where the fuel vapor pressure exceeds the ambient pressure, and the boiling will continue until the fuel vapor pressure is slightly less than the ambient pressure. The quantity of fuel vapor lost by boiling is a function of the initial temperature, vapor pressure, and composition of the fuel. Rapid rates of climb create large differences between tank and ambient pressure and the fuel boils violently. In such cases the vapor bubbles may entrain liquid fuel and cause both vapor and liquid to be lost from the tank vent. These losses are called slugging or surging losses.

Vapor losses are not a new problem and have been encountered with aviation gasoline in reciprocating-engine aircraft. Both vapor and surging losses have been reported in fuel systems for experimental turbojet aircraft and it is anticipated that the combined losses may be severe at high rates of climb unless remedial measures are applied.

Vapor losses from an AN-F-58 type fuel with a Reid vapor pressure of 7.35 pounds per square inch are shown in figure 5. The vapor pressure of the fuel is slightly above the 7-pound Reid vapor pressure allowed by the specification. The data were obtained as part of an extensive laboratory investigation on a mock-up fuel system, sponsored by the Cooperative Research Council. They show the order of magnitude to be expected from vapor losses with no slugging losses encountered. The fuel temperature has a marked effect on vapor loss. At an initial fuel temperature of 60° F, there was no vapor loss up to a simulated altitude of 35,000 feet and slightly less than 5-percent loss at 45,000 feet. At an initial fuel temperature of 110° F, boiling started at about 17,000 feet and at a simulated altitude of 45,000 feet about 13 percent of the initial fuel charge had been lost. A fuel temperature of 110° F seems to be rather high, but temperatures as high as 120° F have been measured in the fuel tanks of aircraft parked in the sun during summer days in the United States. The choice of a 110° F initial temperature therefore represents a severe case, but not an impossible one.

The effect of the initial vapor pressure of a fuel on vapor loss is shown in figure 6. With a fuel temperature of 100° F at the beginning of the simulated climb, the 7.1-pound Reid vapor pressure fuel gave losses comparable to those shown in figure 5. The losses from a 3.2-pound fuel were less than with the 7.1-pound fuel but were 5 percent at 40,000 feet. The fuel with a Reid vapor pressure of 1.1 pound gave no loss up to a simulated altitude of 50,000 feet. The vapor losses for the same fuels at an initial temperature of 70° F are shown in figure 7. As previously indicated, the losses are greatly reduced at the lower fuel temperature. The 7.1-pound fuel gave only a 2.5-percent loss at 38,000 feet; the 3.2-pound fuel gave a 2.5-percent loss at 45,000 feet; and the 1.1-pound fuel gave a 2.5-percent loss at 75,000 feet. It would seem that for most practical cases the vapor losses from a 1.1-pound fuel should not be of serious concern.

The effect of fuel composition on vapor loss is shown in figure 8. The vapor losses are compared for three fuels with practically the same vapor pressure. The JP-3 fuels were prepared from the same base stock by pressurizing in one case with 3-percent butane and in the other case with 13.5-percent pentane. The vapor loss from the fuel pressurized with butane was appreciably lower than the loss from the fuel pressurized with pentane. Both of the JP-3 fuels gave lower losses than the aviation gasoline. Thus, it is shown that fuels of different composition but with practically the same vapor pressure give different vapor losses.

At high rates of climb such as 10,000 feet per minute, boiling becomes so violent that surging occurs and the total fuel losses are usually quite large. The losses are dependent on the simulated rate of climb (which determines the rate of boiling), the initial fuel temperature, the depth of fuel in the tank, the vent-line diameter, and other variables. At fuel temperatures ranging from 85° to 110° F, total fuel losses have been reported as 20 to 50 percent of the initial fuel charge. Such losses were from a tank with a 2-inch-diameter vent. Small vents of 1/2- to 1/4-inch diameter will eliminate surging losses. When boiling occurs, a pressure is quickly built up within the tank, because vapors cannot escape through the small vent at the rate they are evolved. These results with small vents indicate that partial tank pressurization will eliminate surging losses.

There are at least three methods of minimizing fuel losses. One method is to use fuels of 1-pound Reid vapor pressure or lower. The effects of such a fuel on engine performance and other considerations will be discussed in subsequent sections. A second method is to pressurize fuel tanks so that there is no boiling, and a third method is to cool the fuels.

Fuel-tank pressurization. - It has been estimated that pressurization to 9 pounds per square inch absolute would prevent vapor losses from fuels of 7-pound Reid vapor pressure up to a temperature of 110° F. At an altitude of 50,000 feet the pressure inside the fuel tank would be about 7.5 pounds per square inch absolute greater than ambient pressure. Some designers think that the use of reinforcing bands would permit fuel tanks to withstand such pressures without significant weight increases. Other designers think that reinforcing bands and similar devices would be impractical for irregularly shaped tanks and pressurization would involve a weight penalty for aircraft.

A very serious problem is that of designing a self-sealing tank that will withstand a differential pressure of 7.5 pounds per square inch. Present thought indicates the possibilities of building self-sealing tanks that will withstand differential pressures of 2 pounds per square inch, but self-sealing against a 7.5-pound differential seems to be almost impossible.

Several partial solutions to the pressurization problem have been suggested. One possible course of action would be to use a pressure relief valve to provide a lower pressure differential than that required by a completely closed tank and thereby prevent part of the vapor losses. Another partial solution would be to pressurize fuel tanks to allow no loss until an aircraft enters a combat area and



1421  
then de-pressurize the tanks. For many types of mission, such a system would provide an appreciable saving in fuel. When boiling occurs at the time of de-pressurization, the fuel load would be smaller than the original load, and therefore the total fuel loss due to boiling would be less. On long flights at high altitudes, the fuel might be cooled sufficiently to eliminate boiling by the time de-pressurization was necessary. The time required to cool the fuel in flight would depend upon fuel tank construction and location. Integral tanks with no self-sealing material to act as insulation will allow the fuel to cool rather quickly (reference 2), whereas fuel cools very slowly in tanks blanketed with self-sealing material.

The effect of pressurizing to 2 pounds per square inch is shown in figures 9 and 10 for an initial fuel temperature of  $110^{\circ}$  F and a simulated rate of climb of 3000 feet per minute. Figure 9 shows that the vapor losses for an AN-F-58 type fuel with a Reid vapor pressure of 7 pounds are greatly reduced by pressurizing to 2 pounds per square inch. The maximum loss is about 7.5 percent by weight of the initial fuel charge at a simulated altitude of 60,000 feet. Figure 10 shows that the vapor loss for an AN-F-58 type fuel with a Reid vapor pressure of 5 pounds is 5 percent at 60,000 feet. It appears that, if other requirements dictate a high-vapor-pressure fuel, tank pressurization of 2 pounds per square inch would bring fuel losses within reasonable limits. This arrangement would be particularly attractive if the maximum vapor pressure were specified as a Reid vapor pressure of 5 pounds per square inch.

In summarizing the possibilities of tank pressurization, it seems that aircraft for some applications could be built with tank reinforcing bands to withstand tank pressure and with suitable tank construction and location to provide fuel cooling in flight, particularly if self-sealing tanks are not provided. The only penalty to the aircraft would be suitable valves to provide tank pressurization when the fuel is warm and to provide ambient pressure when the fuel is cold. Whether such a system is feasible probably depends upon the application of the airplane and the location and configuration of the fuel tanks. It seems possible that an interceptor airplane might be required to enter combat before the fuel had cooled sufficiently to prevent losses.

Tank pressurization of 2 pounds per square inch could probably be accomplished with present fuel-tank construction and apparently would eliminate surging losses and reduce vapor losses.

Fuel cooling on the ground. - Another method of reducing fuel losses is to cool the fuel before the aircraft leaves the ground.

Potential savings in fuel are indicated in figure 5. A fuel with a 7.35-pound Reid vapor pressure, at 85° F, gave only a 6-percent vapor loss at 40,000 feet and, at 60° F, about 2-percent vapor loss during a simulated climb of 3000 feet per minute. Unfortunately fuel cooling seems to require considerable equipment and personnel. Interceptor aircraft that are fueled and ready for immediate operation would require a portable refrigeration unit that would circulate the fuel through cooling coils until the aircraft was required for action. Possibly, long-range aircraft could be fueled immediately before take-off from underground storage and minimize the requirements for refrigeration. Cooling the fuel, however, seems to be a solution that would be seriously considered only as a last resort.

Consideration of the vapor loss and surging loss problem indicates that the use of a low-vapor-pressure fuel for gas turbine engines would possibly be more satisfactory than pressurization or cooling. The effects of low-volatility fuel on engine performance will be discussed in a subsequent section.

### Aerodynamic Heating

It is well known that supersonic aircraft are subject to aerodynamic heating and this fact must be considered in the selection of a fuel for such aircraft. Apparently fuels are not heated unduly in present aircraft, but aerodynamic heating of fuels probably must be considered in the future. Skin temperatures have been measured on supersonic bodies and have reached relatively high values in short periods of time. Data were obtained during the flight of a V-2 rocket by installing a thermocouple 1.5 feet from the nose of the missile and telemetering the temperatures to a recorder (reference 3). The data in figure 11 show that a skin temperature of about 350° F was reached during a flight time of 100 seconds. The boundary layer reached a temperature of 1800° F during the powered part of the flight.

These results confirmed methods of calculating skin temperatures derived in reference 3, and skin temperatures were calculated for other configurations and flight plans. Results of one calculation are shown in figure 12 for a supersonic airplane. The postulated flight plan shows a climb from 40,000 to 80,000 feet and level flight at that altitude for two minutes. The maximum Mach number in this case was 2.5 and the maximum skin temperature was 400° F.

Calculated skin temperatures for supersonic missiles are shown in figure 13. At an altitude of 80,000 feet the skin temperature of the missile configuration assumed in figure 13 would be 1400° F after a flight time of 100 seconds at a Mach number of 5.

1421

Fuel temperatures in supersonic aircraft have not been measured or calculated because the fuel-tank location and configuration would have a very marked influence on the fuel temperature. Measurements of fuel temperatures in supersonic aircraft would be very helpful in determining the magnitude of the problem to be anticipated from aerodynamic heating. The present state of knowledge would indicate that for sustained supersonic flight aerodynamic heating should be considered. An appreciable increase in fuel temperatures over those now encountered on hot days on the ground would cause excessive fuel vapor pressures as shown in figure 14. A 7-pound Reid vapor pressure fuel will have a pressure of 17 pounds per square inch at a temperature of 150° F, and 105 pounds per square inch at 300° F. A 1-pound Reid vapor pressure fuel will have a vapor pressure of about 3 pounds per square inch at 150° F, and 22 pounds per square inch at 300° F. A 0.1 pound Reid vapor pressure fuel will have a vapor pressure of 6 pounds per square inch at 300° F.

Consideration of aerodynamic heating effects on fuel requirements indicates the need for heat-transfer data applicable to fuel tanks for supersonic aircraft and the possibility of requiring low-volatility fuel for sustained flight at supersonic speeds.

#### Combustion Efficiency

The combustion efficiency that can be attained with fuels of varying volatility and composition is, of course, of primary importance in the selection of a fuel for gas-turbine aircraft engines. Considerable information on the subject has been obtained from investigations both in single combustors and in full-scale engines (references 4 through 15). In this discussion no attempt will be made to treat the data extensively, but some trends will be indicated.

In single combustors it has been possible to investigate the effects of fuel volatility on combustion efficiency over a wide range of fuel flows and combustor inlet-air temperatures, pressures, and velocities. At operating conditions corresponding to low engine speeds at high altitudes, volatile fuels such as gasoline tend to give higher combustion efficiencies than high boiling fuels such as diesel oil. At conditions that correspond to high engine speeds at high altitudes, however, the differences in combustion efficiency tend to disappear.

This trend is shown in figure 15 where combustion efficiency is plotted against volumetric average boiling temperatures for five fuels.

The data were obtained from a tubular combustor at conditions corresponding to an altitude of 40,000 feet at 60- and 90-percent normal rated engine speed (reference 4). At the condition corresponding to 90-percent rated engine speed, the fuels, ranging in volatility from gasoline to diesel oil, gave essentially the same combustion efficiency. At the condition corresponding to 60-percent rated engine speed, the gasoline gave a substantially higher combustion efficiency than the diesel oil.

The combustion efficiencies of three JP-3 type fuels and a JP-1 fuel are shown in figure 16. Combustion efficiencies were determined for the four fuels as a function of simulated engine speed for several altitudes and the data were cross-plotted as shown in figure 16 for two engine speeds. The data were taken from reference 5. The JP-1 fuel had a volumetric average boiling point of 378° F and 15-percent aromatics. The JP-3 fuel designated as "A" had a volumetric average boiling point of 312° F and 19-percent aromatics. The other JP-3 types had higher boiling temperatures and the "C" fuel had 29-percent aromatics. In this comparison at both engine speeds the combustion efficiencies were practically identical for all the fuels up to an altitude of 50,000 feet. At 60,000 feet and 90-percent normal rated speed, the JP-1 fuel gave a higher combustion efficiency than the other fuels. This trend is associated with the establishment of the altitude operational limit and will be discussed later.

The single-combustor data indicate that at simulated high engine speeds, even at high altitudes, fuel volatility has a minor effect on combustion efficiency in tubular combustors.

It has not been feasible to test a wide variety of fuels on full-scale engines, but the results obtained in an evaluation of JP-3 fuels confirm single-combustor data. Fuels conforming to AN-F-58 specifications were compared in three full-scale engines with AN-F-32 fuel. All the engines were designed to operate on AN-F-32. The results indicated no significant differences in combustion efficiency when the different fuels were used at simulated altitudes up to 35,000 feet (references 6, 7, and 8). Typical results for the J33 engine (reference 6) are shown in figure 17. At an altitude of 30,000 feet and a Mach number of 0.60, the specific-fuel-consumption data for AN-F-58 and AN-F-32 fuels fall on a single curve.

In one engine designed for gasoline the combustion efficiencies of AN-F-58 and gasoline were compared up to simulated altitudes of 50,000 feet (reference 9). A plot of combustion efficiency against corrected engine speed is shown in figure 18 for the two fuels. It is

1421

1421  
shown that at a simulated altitude of 5000 feet and a Mach number of zero the combustion efficiencies for the two fuels fall on a single line. A similar plot at a simulated altitude of 50,000 feet and a Mach number of 0.85 is shown in figure 19. At this condition gasoline gave about 20 percent higher combustion efficiency than AN-F-58 at the high engine speed. Apparently at high altitudes the AN-F-58 fuel is less satisfactory than gasoline in this engine designed for gasoline. The trend of combustion efficiency with altitude is shown in figure 20. The figure shows data for rated engine speed at a Mach number of 0.85. At an altitude of 20,000 feet the efficiencies are within 3 or 4 percent of the same value. As the altitude is increased, the AN-F-58 values diverge rather sharply from the gasoline combustion efficiencies. These data indicate that the combustor for this engine was designed to use gasoline and performs better on that fuel than on the higher boiling AN-F-58.

Results from the NACA Lewis laboratory obtained on a 1/4-segment of an annular combustor (reference 10) show high combustion efficiencies for both AN-F-58 and AN-F-32 fuels. A plot of combustion efficiency against altitude is shown in figure 21 for the two fuels. The data are shown for a simulated 90-percent rated engine speed to make them comparable to figure 16 where data are shown for a tubular combustor. The combustion-efficiency data for the two fuels fall on the same line up to an altitude of about 47,500 feet. Above that altitude the AN-F-32 gave an efficiency slightly higher than that obtained with the AN-F-58, which indicates that an annular combustor can be designed to operate efficiently on a non-volatile fuel if such a fuel is required by other considerations.

As previously indicated, the results obtained with different fuels depend on the design of the combustor. In order to understand clearly the effects of fuels and fuel injection on combustion in a turbojet engine, it is necessary to consider the flow characteristics within the combustor. Satisfactory burning can be achieved if a region is provided where combustible mixtures are obtained and where gas velocities are low. Research has shown (reference 16) that these conditions exist if air necessary for complete combustion of the fuel is introduced over about one-half the combustor length. With present methods of liquid injection the fuel is introduced at one place in the combustor. It must vaporize and mix gradually with the air if combustible mixtures are to be provided over the combustor length required for the entry of air.

If all the fuel vaporizes quickly and mixes rapidly with the air in the upstream end of the combustor, zones of gas will be created

that are too rich to support combustion. As these gases are swept downstream, more air will mix with the gases and a combustible mixture will be provided. After this occurs, however, there may be insufficient time for complete combustion before the reaction is quenched by cooling air, and the mixture is swept out of the combustion chamber.

On the other hand, if the fuel vaporizes too slowly, part of the gases in the upstream end of the combustor will be too lean to burn. In this case the fuel will vaporize further as it passes downstream and a combustible mixture may be formed, but again there may be insufficient time for complete combustion before the mixture is swept out of the combustion chamber.

Thus, it is possible to encounter combustion difficulties if fuels are vaporized either too slowly or too rapidly. It is also apparent that the lower the velocities in the combustion chamber the better the chances are for the fuel and air to form a suitable mixture and to burn completely before being swept out of the combustor. Unfortunately low velocities require a large cross-sectional combustor area that may not always be compatible with minimum engine size.

Fuel injection. - In the case where the fuel vaporizes too slowly, the use of a fuel nozzle that would provide better atomization would tend to raise combustion efficiency. This has been shown to be the case, as illustrated in the following figures. One type of fuel nozzle (reference 17) that has been studied at the Lewis laboratory (fig. 22) is a simple swirl-type nozzle to which has been added a divergent section. Apparently at low flows the fuel tends to follow the contour of this section and then fan out into a  $180^\circ$  angle. Photographs of fuel sprays from this nozzle are compared in figure 23 with photographs of sprays from the original nozzle. At a fuel flow of 20 pounds per hour and a pressure of 2 pounds per square inch, the original nozzle gave a bulb-type spray, whereas the modified nozzle gave a wide-angle spray. As fuel flow was increased, the differences in spray configuration were not so marked.

The combustion efficiencies obtained with the two nozzles are presented in figure 24 as a function of fuel flow in pounds per hour. At a simulated altitude of 45,000 feet and rated engine speed in a tubular combustor, the original nozzle gave a combustion efficiency of 50 percent at low fuel flow. As the flow was increased, the combustion efficiency increased to about 90 percent. The flared nozzle at low fuel flow gave a combustion efficiency of about 100 percent with a slight drop in efficiency as fuel flow was increased. It may be concluded that, for this particular combustor, combustion efficiency can be improved at low fuel flows by improved fuel-spray configuration.

1421

1421

The effects of fuel atomization on performance have also been determined in an annular combustor by operating with nozzles of different capacities (reference 14). Typical results are shown in figure 25. Temperature rise through the combustor is plotted against fuel flow at a very high altitude. The inlet air to the combustor was held constant at a pressure of 9.2 pounds per square inch, a temperature of 240° F, and a velocity of 200 feet per second. Gasoline was introduced into the combustor through 10.5-gallon-per-hour nozzles and 3.0-gallon-per-hour nozzles. For a given fuel flow the 3.0-gallon-per-hour nozzle gave a more finely atomized spray than the 10.5-gallon-per-hour nozzle inasmuch as the pressure drop across the nozzle was greater. The data obtained with the 10.5-gallon-per-hour nozzles show increasing temperature rise as the fuel flow is increased. The 3.0-gallon-per-hour nozzles, however, gave increasing temperature rise at low flows, but gave practically no increase in temperature rise at the higher flows and blew out at a fuel flow in excess of 400 pounds per hour. This figure illustrates a condition where the fuel vaporizes too rapidly and creates zones that are too rich to support combustion near the fuel nozzle, and eventually the flame blows out. It is important to keep in mind the fact that the combustor was designed to operate with gasoline and 10.5-gallon-per-hour nozzles; increased fuel vaporization achieved with the 3.0-gallon-per-hour nozzle was harmful in this case.

The performance of diesel fuel has been examined in the same combustor with results shown in figure 26. The data obtained with 3.0-gallon-per-hour nozzles show a markedly higher temperature rise at lower fuel flows than that obtained with 10.5-gallon-per-hour nozzles, but at high fuel flow rates the use of the 10.5-gallon-per-hour nozzles gave a higher temperature rise than with the 3.0-gallon-per-hour nozzles. These curves indicate that even with a high boiling fuel such as diesel fuel it is possible at severe operating conditions to atomize the fuel too well and reach a condition where additional fuel gives no additional heat release in the combustor.

At an inlet-air temperature lower than that illustrated in figures 25 and 26 a comparison (fig. 27) of the performance of gasoline and diesel oil indicates that a temperature-rise limit is reached with gasoline but not with diesel oil (reference 14). This comparison was made using a 10.5-gallon-per-hour nozzle in the combustor. If the temperature required to operate the engine at a constant speed is greater than that attainable with the gasoline, then the altitude operational limit has been exceeded for the gasoline; but the required temperature rise could be attained with diesel oil although the combustion efficiency would be low.

The occurrence of a temperature-rise limit as shown for gasoline establishes altitude operational limits, which are discussed in the following section.

#### AIRCRAFT RELIABILITY

The fuel used in aircraft powered with turbojet engines may have an influence on the reliability of the engine and fuel system and may also have a marked influence on the maintenance required. The discussion of the various factors to be considered will follow the outline in figure 1.

#### Altitude Operational Limits

At high altitude conditions it is possible to reach an altitude and an engine speed where the combustor will not deliver enough temperature rise to operate the engine at constant speed. This condition is defined as the altitude operational limit. Such a temperature-rise limit is usually encountered before blow-out occurs.

It was shown in figure 27 that gasoline reaches a temperature-rise limit of about 1200° F under the conditions specified, whereas diesel oil does not reach such a limit. A comparison of the altitude operational limits of these fuels over a range of engine speeds with an annular combustor is presented in figure 28. At low engine speeds the gasoline gave the higher altitude operational limit, apparently because the diesel oil is not sufficiently vaporized to give correct fuel-air mixtures at low fuel flows, corresponding to the low engine speeds. However, at higher engine speeds the diesel oil gives the higher altitude operational limits, because the gasoline apparently vaporizes too readily and creates rich mixtures near the fuel nozzles that are too rich to burn. After the mixture is swept downstream in the combustion chamber where there is sufficient air to provide a combustible mixture, there is insufficient time for good combustion.

The theory that rich mixtures cause the altitude operational limits are substantiated by the data in figure 29. Altitude operational limits are presented for gasoline injected into the combustion chamber with 3.0- and 10.5-gallon-per-hour nozzles. Except at very low engine speeds the higher altitude operational limits were obtained with the 10.5-gallon-per-hour nozzles. These results suggest again the idea that the 3.0-gallon-per-hour nozzles produced an overly rich zone near the fuel nozzles.



1421

The effect of the molecular structure of fuels on altitude operational limits is shown in figure 30. Data are shown for benzene and a mixture of isoheptanes. The two materials boil in the same range but the benzene has a faster flame speed than the isoheptanes. It is suggested that near the altitude limit both fuels form overly rich mixtures near the fuel nozzle. When a point is reached part way through the combustor, where the fuel-air mixture becomes satisfactory for combustion, the benzene burns more rapidly than the isoheptanes and gives a higher heat release before being swept out of the combustion chamber. This fact could account for the higher altitude operational limit obtained with benzene at the high speeds.

The effects of fuel volatility on altitude operational limits have also been observed in tubular combustors (reference 18). The altitude operational limits of a gasoline and a kerosene-type fuel are compared in figure 31. The results are consistent with the data from the annular combustor in that kerosene gave a higher altitude operational limit than the gasoline.

The trend was also shown for a tubular combustor in figure 16, where combustion efficiencies of AN-F-32 were compared with efficiencies for three AN-F-58 fuels, which were more volatile than AN-F-32. At 60-percent rated engine speed the AN-F-32 was the only fuel that would burn up to 60,000 feet. At 90-percent rated speed the AN-F-32 burned more efficiently at 60,000 feet than the other fuels.

A summary of the information on altitude operational limits indicates that the limits are caused by the formation of fuel rich zones near the fuel nozzles. The highest limits will be obtained by proper matching of the combustor design, the fuel injection system, and the fuel volatility. The results indicate that the altitude operational limits of present engines would not be lowered by reducing the fuel volatility from an AN-F-58 type to an AN-F-32 type.

#### Altitude Starting

Another gas-turbine engine problem that must be considered in the selection of a fuel is starting. It is necessary to be able to start gas-turbine engines at high altitudes after the engines have been inoperative for several hours. In this case the engine parts, the fuel, and the air are cold. A second requirement is the ability to re-start after an accidental engine blow-out. A third requirement is to be able to start at sea level under all climatic conditions, including extremely cold weather.

The starting of a full-scale engine involves three separate operations: (1) ignition in the region of the spark plugs, (2) propagation of the flame to all combustors, or to the complete annulus of an annular combustor, and (3) acceleration of the engine from starting speed to operating speed. Each one of the separate steps may limit the altitude at which a complete start can be accomplished. This fact is illustrated in figure 32. Altitude is plotted against Mach number and the three lines define limiting altitudes for ignition, flame propagation, and acceleration. In the original engine, ignition could be obtained up to 50,000 feet at a Mach number of 0.25 but fell rapidly as the Mach number was increased, as indicated by the solid line. The ignition limit was improved by the use of extended spark electrodes to a value of 45,000 feet at a Mach number of 0.6, and 35,000 feet at a Mach number of 0.85. Then the propagation limits were determined and finally the acceleration limit was determined. The figure shows that at a Mach number of 0.4 ignition could be accomplished up to 45,000 feet; that flame would propagate to all combustors up to an altitude of about 40,000 feet, but the engine could not be accelerated at an altitude above 27,500 feet. Therefore, the starting limit of the engine was 27,500 feet.

In order to allow starting of turbojet engines at the altitudes required, all three phases of the problem must be investigated. The ignition problem can be investigated in a single combustor, and some work has been completed on this phase of the problem.

Single-combustor results. - In order to determine the effects of fuel volatility on ignition, three fuels were investigated in a J33 single combustor (reference 19). A simple swirl-type fuel nozzle was used with the standard ignition energy and spark plug. The fuel system for the combustor was arranged so that fuel flow could be varied. The comparison of the fuels was based on the quantity of fuel required to obtain ignition. The three fuels included a 7-pound Reid vapor pressure fuel of the AN-F-58 type, a 4.5-pound Reid vapor pressure fuel of the AN-F-58 type, and an AN-F-32 fuel.

The results obtained at sea-level pressure are shown in figure 33. Inlet-air temperatures are plotted against the fuel flow required for ignition at each condition. The fuel and air temperatures were the same at each test condition. Ignition could be obtained at fuel flows to the right of the lines and no ignition to the left of the lines. The results show that a 7-pound Reid vapor pressure fuel required less fuel for ignition than a 4.5-pound fuel over the range of temperature investigated. The 4.5-pound fuel required considerably less than the AN-F-32 fuel. At the inlet temperature of  $-20^{\circ}$  F the quantity of fuel required to ignite the AN-F-32 corresponded to a fuel-air ratio of 0.05.

3  
1421

The trends obtained at simulated altitude conditions are shown in figure 34. The 7-pound fuel again required a smaller quantity of fuel for ignition than the other fuels. The quantity of fuel required increased as the volatility of the fuel decreased. The range of data was limited by the laboratory facilities. Probably all the fuels could have been ignited at higher altitudes, if the proper conditions could have been obtained. The trends shown at these relatively low altitudes seem to be mostly the effect of ambient temperature.

Air- and fuel-temperature effects are summarized in figure 35. The critical fuel flow to obtain ignition is plotted against the 10-percent-evaporated temperature of the fuel for lines of constant ambient temperature. This plot might be useful in comparing the fuels investigated with other fuels. For example, the 1-pound Reid vapor pressure fuel discussed in this paper has a 10-percent-evaporated temperature of 248° F as shown in table I. At -20° F under the conditions of this investigation a 1-pound fuel would require 90 pounds per hour for ignition as compared to 40 pounds per hour for the 7-pound fuel and 140 pounds per hour for AN-F-32.

Full-scale-engine results. - The effect of fuel volatility on engine starting is shown in figure 36. The data were obtained on two full-scale engines, one with tubular combustors and the other with an annular combustor (references 6 and 9, respectively). Altitude is plotted against flight Mach number. The results on the left side of the figure show that the engine with tubular combustors could be started with AN-F-58 fuel at all altitudes below the solid line. The engine could be started with AN-F-32 at all altitudes below the dotted line. In this case the starting limit was increased 15,000 feet by use of AN-F-58 fuel.

The engine with the annular combustor designed for gasoline gave the higher starting limit with gasoline as a fuel. In the region of low Mach numbers the AN-F-58 fuel gave a starting limit about 10,000 feet lower than gasoline. At higher Mach numbers the gasoline would allow starts between 20,000 and 25,000 feet, whereas the AN-F-58 could not be started in this region.

A further indication of the effects of fuel volatility on engine starting are shown in figure 37 (reference 20). Results are compared for an engine with a centrifugal compressor and an axial-flow compressor. Both engines had tubular combustors. The curves on the left side of the figure are repeated from figure 36 for purposes of comparison. The curves on the right side of the figure show starting limits obtained with AN-F-58 and with a 1-pound fuel (table I). At high Mach numbers

the differences were not large, but at 0.40 Mach number the AN-F-58 fuel would allow ignition about 8500 feet higher than the 1-pound fuel. At a Mach number of 0.25 the AN-F-58 could be ignited to an altitude of 35,000 feet, whereas no ignition was obtained for the 1-pound fuel at this condition.

The results of these investigations show that, in the engines investigated, volatile fuels can be ignited at higher altitudes than less volatile fuels.

In addition to the effects of fuel volatility, it is necessary to know the effects of spark-plug location, spark energy, and fuel spray.

The results obtained by extending the spark electrodes into the combustor are shown in figure 38. In this investigation the spark plugs of a J35 engine were replaced by spark plugs with extended electrodes. The results are plotted as the altitude limit for successful ignition against the distance the spark gap projects into the combustion chamber. At a Mach number of 0.85 the ignition limits were raised from 10,000 feet to 35,000 feet by extending the electrodes from 1 inch to  $1\frac{7}{8}$  inches into the combustion chamber. Further extension to the center line of the combustor gave no further improvement in ignition limits. At a Mach number of 0.60 the altitude ignition limits were raised from 20,000 feet to 45,000 feet by extending the electrodes to the center line of the combustor. At a Mach number of 0.40 ignition could be obtained at 45,000 feet with the original spark plug. Extension of the electrodes to  $1\frac{7}{8}$  inches raised the limit to 50,000 feet.

These data indicate that marked improvements can be obtained by proper location of the spark electrodes. It may be possible to ignite less volatile fuels successfully by the proper location of spark electrodes, optimum fuel spray, and optimum air-flow patterns. This type of research is under way at the present time.

#### Carbon Deposits

The carbon-forming tendencies of fuels will probably have an influence on the ultimate selection of a turbojet fuel. The amount of carbon deposited in a combustion chamber depends upon the combustor design, the conditions of operation, the burning time, and the fuel properties. The influence of fuel volatility and molecular structure is illustrated in figure 39, with the other variables held constant.

1421

It is shown that commercial isoheptanes, a paraffinic fuel with a volumetric average boiling temperature of  $182^{\circ}\text{F}$ , gave only 1 gram of carbon when operated in an annular combustor for 2 hours. Benzene, an aromatic fuel with a volumetric average boiling temperature of  $172^{\circ}\text{F}$ , gave 30 grams of carbon when operated for the same length of time. Ethylbenzene, which is an aromatic fuel boiling at  $271^{\circ}\text{F}$ , gave an even higher carbon deposition than benzene. These are typical results obtained from the examination of a large number of fuels in both annular and tubular combustors. It is indicated that aromatic fuels form more carbon than paraffinic fuels and that increasing the boiling temperature of the fuel tends to increase the amount of carbon deposited. The isoheptanes have a hydrogen-carbon ratio of 0.19 and the benzene has a hydrogen-carbon ratio of 0.08. The other aromatics have a slightly higher ratio, so it may be observed that hydrogen-carbon ratio is one method of expressing the aromaticity of a fuel. Thus it may be stated that fuels with a low hydrogen-carbon ratio will tend to form more carbon than fuels in the same boiling range that have a high hydrogen-carbon ratio. Also, high-boiling-temperature fuels tend to produce more carbon than low-boiling-temperature fuels of the same hydrogen-carbon ratio.

The results of carbon-deposition tests may be generalized for both pure hydrocarbons and complex mixed fuels by correlating the carbon forming tendency with hydrogen-carbon ratio and volumetric average boiling temperature of the fuel. A plot of this relation obtained in an annular combustor is shown in figure 40. If one selects the volumetric average boiling temperature of the fuel and proceeds vertically to the proper hydrogen-carbon ratio line and then proceeds horizontally to plot the amount of carbon formed with each fuel, the data form a straight line for a series of fuels. The data shown in figure 40 were obtained by operating each fuel in a combustor for 2 hours at a simulated engine condition of sea level and 50-percent rated engine speed (reference 21). After the correlation line is established for a given operating condition, the chart can be used to predict the amount of carbon that will be formed under the same conditions of operation for which the correlation was established. An example of its use would be to predict the amount of carbon deposit to be expected from a fuel with a volumetric average boiling point of  $300^{\circ}\text{F}$  and a hydrogen-carbon ratio of 0.12. Find the point  $300^{\circ}\text{F}$  on the boiling temperature scale and then proceed vertically to the 0.12 hydrogen-carbon ratio line and then proceed horizontally to the correlation line. From there proceed down to the carbon scale, and the correlation predicts that 25 grams of carbon will be formed from the fuel in question under the conditions specified in the figure.

A comparison of the carbon forming tendencies of JP-3 type fuels with AN-F-32 is shown in figure 41. The data were obtained in a single tubular combustor at a simulated altitude of 20,000 feet and 90-percent normal rated engine speed. The data are plotted as carbon deposited against operating time. Two of the JP-3 type fuels gave less carbon than the AN-F-32. The third JP-3 fuel gave more carbon than the AN-F-32. This third fuel was made by adding high-boiling aromatics to the JP-3 "A" with an average boiling point of 312° F and 19-percent aromatics (reference 22). The 29-percent aromatics exceed the allowable aromatics in the present MIL-F-5624 specification.

The data of figure 41 are correlated with volumetric average boiling temperature and hydrogen-carbon ratio in figure 42. In this figure the grid of hydrogen-carbon lines and boiling temperatures are plotted as  $K$ , for which the equation is

$$K = (t + 600) (0.7) \frac{H/C - 0.207}{H/C - 0.259}$$

where  $t$  is the volumetric average boiling temperature and  $H/C$  is the hydrogen-carbon weight ratio. The figure shows data for the AN-F-32 fuel and the three JP-3 fuels. Separate correlations are shown for a simulated altitude of 20,000 feet, 90-percent rated speed for combustor operation of 2, 4, 6, and 10 hours. A plot is also shown for 6-hour operation at a simulated altitude of 35,000 feet and 90-percent rated speed. It is of interest to note that less carbon was formed at 35,000 feet than at 20,000 feet. This trend will also be shown in a subsequent figure.

It is possible to predict the relative amount of carbon that the 1-pound fuel described in table I would give relative to the JP-3 and the AN-F-32 fuel described in the same table. The fuel designated as JP-3 in table I is designated JP-3-A in figure 42.

The volumetric average boiling temperature is obtained by averaging the values for the 10-, 30-, 50-, 70-, and 90-percent evaporated temperatures. The volumetric average boiling temperature for the 1-pound fuel is 359° F. The hydrogen-carbon ratio is 0.155. The calculated  $K$  value is 336 and the carbon deposits may be predicted from figure 42.

At a run time of 2 hours at the simulated altitude of 20,000 feet, the JP-3-A gave 3.1 grams of carbon, the AN-F-32 gave 6.5 grams, and the predicted value for the 1-pound fuel is 5.7 grams. At a run of 10 hours the JP-3-A gave 14.9 grams of carbon and the AN-F-32 gave 24.4 grams. The predicted value for the 1-pound fuel is 23.5 grams.

These data illustrate the fact that a low-volatility fuel such as a 1-pound Reid vapor pressure fuel derived from an AN-F-58 stock will give more carbon deposit than the original AN-F-58.

The trends of carbon deposition with increasing altitude was mentioned in the discussion of figure 42. The trend is further illustrated in figure 43 (reference 21). The data are plotted as carbon deposited at altitudes of 20,000, 30,000, and 40,000 feet in an annular combustor operated  $1\frac{1}{4}$  hours at 100-percent rated speed. The fuels investigated were aromatic solvent, benzene, and AN-F-32. There was a marked decrease in carbon deposits as altitude was increased, which cannot be explained entirely on the basis of reduced fuel flow. It may be due to (1) the angle of fuel spray changing and impinging less fuel on the combustor walls, (2) reduced air temperature, (3) changed inlet-air velocity, or (4) a change in the combustion process at low pressures.

The reduced carbon deposits in the tubular combustor as altitude is increased can be explained on the basis of reduced fuel flow. The grams of carbon deposited per pound of fuel burned remained substantially the same over the limited range investigated in reference 22.

The trend in engine design toward higher pressure ratios and higher mass flows will tend to increase carbon deposits in combustors of present design. This trend, plus the potentially higher carbon-forming fuels being considered for future use, indicates the need for further research on suitable methods of eliminating carbon deposits.

### Fuel Pumping

The effect of fuel volatility on the performance of fuel pumps has been studied extensively under sponsorship of the Coordinating Research Council. An example of the performance of an aircraft fuel pump with two jet fuels is shown in figure 44. The data were obtained by putting the fuel system into a tank that could be evacuated and measuring the fuel flow delivered by the pump under various operating conditions. The data shown compare the fuel flows of AN-F-32 with flows of AN-F-58. The initial fuel temperature was  $110^{\circ}$  F in each case and the simulated rate of climb was 5000 feet per minute. The quantity of AN-F-58 fuel delivered by the pump was much lower than the quantity of AN-F-32 delivered. If volatile fuels are to be used in future engines, fuel tanks must be pressurized or high-capacity booster pumps must be used to deliver fuel to the primary fuel pump.

### Physical and Chemical Properties

The physical and chemical properties of an aircraft fuel have an important bearing on the reliability of the aircraft engine and fuel system. The volatility characteristics have been discussed throughout this report, so will not be considered in this section.

Freezing point. - An important physical characteristic of a fuel is the freezing point. It is obvious that an aircraft fuel must not freeze at temperatures encountered at high altitudes. In addition, the drum storage of fuel under Arctic winter conditions would impose conditions just as severe as those normally encountered in flight. A maximum freezing point of  $-76^{\circ}$  F has been established with these requirements in mind. The British with less severe climatic conditions specify a minimum freezing point of  $-40^{\circ}$  F.

Investigations have shown (reference 23) that ambient temperature at an altitude of 55,000 feet may be as low as  $-137^{\circ}$  F. A recent memorandum from the Navy Department, Bureau of Aeronautics, proposed a standard cold-day temperature of  $-130^{\circ}$  F at an altitude of 55,000 feet. Calculated from this standard, an airplane cruising at 150 miles per hour at 55,000 feet would have a skin temperature of  $-103^{\circ}$  F. The memorandum suggests that power-plant equipment should be designed to operate at  $-103^{\circ}$  F. At such a flight condition, fuel in integral tanks might be cooled to temperatures below the presently specified maximum freezing point.

The freezing point of the fuel specification definitely limits the quantity of fuel that can be made available for turbine engines. In reference 24 it is shown that an AN-F-32 fuel could be made available in relatively large quantity if a freezing point of  $-40^{\circ}$  F were specified. It is stated that a low-volatility fuel, with a  $100^{\circ}$  F flash point, that would meet a freezing point of  $-76^{\circ}$  F would be available in 13 percent of the crude oil processed. If the freezing point were raised to  $-50^{\circ}$  F the fuel could be made available in 20 percent of the crude oil.

Some experimental AN-F-58 fuels have not met the freezing point required by the specification. If a lower vapor pressure fuel such as a 1-pound Reid vapor pressure fuel is required for optimum aircraft performance, it may be necessary to reduce the end point of the fuel in order to meet the freezing-point requirement. If the fuel specification were revised to require a freezing point below  $-103^{\circ}$  F, it would drastically reduce the potential supply of JP-3 type fuel and would almost eliminate the possibility of producing a 1-pound Reid vapor pressure fuel from JP-3 type stocks. If it is necessary to



anticipate temperatures in the neighborhood of  $-100^{\circ}$  F, it may be necessary to heat the fuel by use of an available source of heat such as oil coolers.

This section may be summarized by stating that the freezing-point requirement limits the supply of fuel for aircraft turbine engines. The end point of a 1-pound Reid vapor pressure fuel might have to be reduced to meet the present freezing-point requirement. A lower freezing point than now specified would drastically limit the types of fuel that could meet the specification.

Ice formation. - A problem somewhat akin to the freezing point of the fuel is the formation of ice in fuels at low temperatures.

All hydrocarbons dissolve a small quantity of water. As the temperature of the fuel is decreased, the quantity of water that can be dissolved in hydrocarbons is reduced. If a hydrocarbon is saturated with water at room temperature and the temperature is then lowered, water will separate out of the fuel as suspended droplets. At temperatures below  $32^{\circ}$  F the water may freeze into small crystals or it may remain as supercooled water droplets.

Aircraft fuels are usually saturated with water when they reach the field. When the fuels are cooled during flight, the water may form fine ice crystals that will tend to clog fuel filters or the water may remain supercooled until it contacts the fuel filter and then freeze on the filter. The present remedial action is to flush the fuel filter with isopropyl alcohol and dissolve the ice when the pressure drop across the fuel filter becomes too great.

The composition and volatility of fuels have an influence on the quantity of water that will be dissolved. Aromatics tend to dissolve more water than paraffins and high boiling fuels tend to dissolve more water than low boiling fuels. The trend of water solubility with hydrogen-carbon ratio of fuels and temperature is shown in figure 45. It is shown that fuels of low hydrogen-carbon ratio dissolve more water than fuels of high hydrogen-carbon ratio.

It seems that restriction of the fuel type would probably be an unsatisfactory control on the possibility of ice formation, because it would make the specification unduly restrictive. The use of alcohol or possibly heating of the fuel filter seems to be a more satisfactory solution to ice formation in the fuel.

Corrosion and rubber swell. - Other properties of the fuel that may affect the reliability of the airplane include the possibility of corrosive materials being present in the fuel, and the possibility of fuel components causing swelling and deterioration of rubber gaskets and fittings.

Naphthenic acids may occur in jet fuels, and inasmuch as these acids are corrosive they must be removed by alkali treatment. Mercaptans in concentrations that can normally occur in AN-F-58 type fuels tend to cause swelling and deterioration of synthetic rubbers and to cause some corrosion of cadmium-plated parts. The mercaptan concentration of jet fuels, however, will probably be restricted to a concentration of 0.005 in order to prevent objectionable odors. In such concentrations, mercaptans cause no undue swelling or deterioration of synthetic rubbers. Laboratory tests are still under way to determine if mercaptans in 0.005-percent concentration will corrode metals used in aircraft fuel systems. The removal of naphthenic acids and mercaptans to a concentration of 0.005 percent will require treatment of jet fuels, but will not decrease the supply.

Gum. - The accelerated-gum specification apparently is sufficiently liberal to allow the inclusion of cracked stocks necessary for maximum production. Information on the effect of gum on fuel systems and fuel-injection nozzles has not been reported. Investigations are under way to determine the stability of JP-3 fuels to long-term storage.

Preliminary information on the effect of gum on carbon deposits has shown that quantities of gum by the accelerated method up to 100 milligrams or more show no effect. Quantities in the order of 300 milligrams or more cause small increases in carbon deposits.

## AIRCRAFT SAFETY

### Fire

The possibility of the occurrence of fire in aircraft during flight and after a crash is influenced by the characteristics of the fuel. The possibility of ignition is a function of fuel volatility and composition (reference 25) and the rate the fire spreads is a function of volatility.

The relative ignitability of fuels can be expressed in terms of spontaneous ignition temperature and flash point. The spontaneous

1421

1421  
ignition temperature (reference 26) of a fuel is the temperature a heated surface must attain to cause ignition of the fuel under investigation. Although this temperature varies with different methods of determination, a comparison of spontaneous ignition temperatures determined in the same apparatus for several fuels gives a relative indication of the possibility of ignition of the fuels due to hot engine parts. A comparison of some spontaneous ignition temperatures for fuels of interest is shown in table II. The spontaneous ignition temperatures are shown for an aviation gasoline and four jet fuels. An AN-F-32 fuel is compared with an AN-F-58 fuel, a 4-pound Reid vapor pressure fuel, and a 1-pound Reid vapor pressure fuel. The latter two fuels were prepared by distilling the volatile components from the AN-F-58 base stock. An analysis of three of the fuels is shown in table I. There are only small differences in the spontaneous ignition temperatures of the JP-3 and low-vapor-pressure fuels, all of which are much lower than the value for gasoline. This marked difference is due to the fact that the average boiling temperature of the gasoline is lower than for any of the jet fuels and the gasoline contains a relatively high concentration of branched hydrocarbons. Volatile and branched hydrocarbons have high spontaneous ignition temperatures (reference 25). It may be concluded that jet fuels ignite on hot metal surfaces at lower temperatures than aviation gasoline. It is also indicated that changing the volatility of jet fuels will not cause significant changes in the spontaneous ignition temperature.

Included in table II are the flash temperatures for these fuels. The temperatures indicated represent the fuel temperatures required to produce a combustible mixture above the surface of the liquid fuel according to the A.S.T.M. procedure (reference 27). All of the fuels except AN-F-32 produce combustible mixtures at temperatures below common sea-level ambient temperatures. The AN-F-32, with a flash point of 120° F, is unlikely to form combustible mixtures in case of fuel spillage onto surfaces at low temperatures.

Although there are no data to show the effects of fuel flash point on aircraft fires it seems reasonable to believe that a high flash-point fuel would offer some merits as a jet fuel.

In the case of fuel leakage during flight, it would seem reasonable to believe that a low-volatility fuel would be less likely to produce a vapor that would reach an ignition source and cause a fire than would a volatile fuel.

A low-volatility fuel might also offer some advantages in preventing fires in aircraft crashes where fuel is spilled without the

formation of fuel sprays. In such a case a volatile fuel would produce vapors that might reach an ignition source, whereas a low-volatility fuel would not produce vapors. If a large quantity of fuel spray were formed in a crash, the spray could give a violent explosion with either a volatile fuel or a low-volatility fuel.

Flame velocity. - Fuel vapor pressure has an important influence on the rate a fire will spread after ignition has occurred. The rates of flame travel across various fuels in an open tray were obtained by the Shell Oil Company and a summary curve is shown in figure 46 as a function of vapor pressure. Such data may give some indication as to the rate a fire might spread after an aircraft crash. At vapor pressures of 1.2 pounds per square inch to 3.1 pounds per square inch, the flame velocities were about constant at almost 800 feet per minute. At lower vapor pressures the flame velocity decreased linearly. A 1-pound Reid vapor pressure fuel at a temperature of 100° F would give a flame velocity of about 600 feet per minute, which seems to be an insignificant reduction from the 800 feet per minute obtained with higher vapor pressure fuels. At lower temperatures, however, the vapor pressure of the 1-pound fuel would be reduced. For example, at 70° F the vapor pressure would be about 0.5 pound per square inch as indicated in figure 47. In this case the flame velocity would be about 250 feet per minute, which might offer a slight advantage over fuels of higher vapor pressure. It is indicated in figures 46 and 47 that 4- and 7-pound Reid vapor pressure fuels would give no decreased flame speed at 70° F.

Really significant reductions in flame velocity are shown for fuels with vapor pressures below 0.2 pound per square inch. An AN-F-32 fuel with a negligible vapor pressure even at 100° F would give very slow flame velocities. There might be types of aircraft crash where such a slow rate of flame travel would allow time for evacuation of the airplane while cabin temperatures were still below the limit for survival.

#### Combustible Mixtures in Fuel Tanks

When hydrocarbon fuels are stored in tanks vented to the atmosphere, combustible mixtures of fuel vapor and air will exist under certain conditions of temperature and pressure. The conditions for combustible mixtures are shown for three fuels in figure 48 (reference 28). Regions of combustible mixtures exist within the enclosed areas. It is shown that a gasoline with a Reid vapor pressure of 7 pounds per square inch will create a combustible mixture in a vented fuel tank at sea level at temperatures ranging from -40° F to about

1271  
1221

15° F. It is likely that on winter days aircraft landing with cold gasoline have combustible mixtures in the fuel tanks. Apparently the application of proper techniques and precautions in fueling airplanes has prevented accidents from the existence of combustible mixtures. At temperatures below -40° F there is insufficient vapor above the fuel to give a combustible mixture, and at temperatures above 15° F there is too much fuel vapor to form a combustible mixture. The regions for combustible mixtures at altitude conditions are shown in the figure. At 40,000 feet a 7-pound Reid vapor pressure fuel will create a combustible mixture in the fuel tank when fuel temperatures range from about -75° to -40° F. Combustible mixture limits have not been reported for JP-3 fuel, but the regions of inflammability are probably at least as wide as for aviation gasoline.

Regions of combustible mixtures for a 1-pound Reid vapor pressure fuel and an AN-F-32 fuel are also shown on the figure. At sea level the 1-pound fuel will give combustible mixtures at fuel temperatures from 35° to 100° F and the AN-F-32 will give combustible mixtures from about 90° to about 175° F.

A comparison of the relative hazards of the three fuels indicates that the 1-pound fuel would tend to form combustible mixtures at sea level more frequently than the other fuels. In fact, a combustible mixture would exist above the 1-pound fuel during most of the year.

Unfortunately, there are practically no data on temperatures attained by fuels during long flights, so it is impossible to predict under what conditions combustible mixtures might exist during flight. It is possible that during a prolonged flight at 30,000 feet, a 1-pound fuel would be cooled below 0° F and the vapor space in the fuel tank would not contain a combustible mixture.

The data shown in figure 48 were obtained by the use of a spark as an ignition source. A higher energy source or an incendiary bullet will extend these curves to very low temperatures and to somewhat higher temperatures. Incendiary bullets will extend the inflammability limits more at the low temperatures, or in the lean region, than at the high temperatures. An incendiary bullet extends the lean inflammability limits probably because of impact. When a bullet hits a tank, probably a spray is created that forms an explosive mixture.

Therefore, for consideration of fuels for combat aircraft the left portions of the curves have no meaning. Thus, an AN-F-32 fuel will give an explosive mixture from the combustible zone indicated all the way to the very low temperatures of -80° and -120° F. The 1-pound fuel would give combustible mixtures from the right side of the area

for the 1-pound fuel to be the very low temperatures. The 7-pound fuel would give similar results. The 7-pound fuel is less likely to be exploded by an incendiary bullet than the other fuels because it is more likely to form mixtures too rich to burn. Even with the 7-pound fuel, however, there is still a range of temperatures where explosions in fuel tanks could occur.

Maneuvers of aircraft also create conditions not considered in figure 48. It seems likely that an airplane could be flying at 40,000 feet with a 7-pound fuel at a temperature of  $-20^{\circ}$  F and have a mixture too rich to explode in the fuel tank, but during maneuvers drop to an altitude of 20,000 feet and have an explosive mixture in the tank. Actually, in any dive, air will be aspirated into the fuel tank and an explosive mixture is probably formed in many cases.

It is suggested, therefore, that only by providing an inert gas over the surface of the fuel will all explosive mixtures in fuel tanks be eliminated. If inert atmospheres are used in fuel tanks, then the ultimate selection of a jet fuel need not be influenced by the possibilities of explosive mixtures in tanks.

## LOGISTICS

### Fuel Storage and Shipment

The effects of volatility on the possibilities of aircraft fire and fuel-tank explosions also apply to the manufacture, bulk storage, and shipment of fuels. The data in table II and in figure 48 apply to these problems as well as those previously discussed. During bulk storage of a 7-pound Reid vapor pressure fuel and shipment by tank car, tankers, etc., the fuel vapors in the tank prevent the formation of an explosive mixture at all temperatures above  $15^{\circ}$  F. At temperatures between  $15^{\circ}$  and  $-40^{\circ}$  F explosive mixtures exist. Apparently great quantities of aviation gasoline have been stored and transported during winter months when air temperatures were within these limits and probably in many cases fuel temperatures were also in this region.

As previously mentioned a 1-pound Reid vapor pressure fuel would provide a combustible mixture in tanks in the temperature region from  $35^{\circ}$  to  $100^{\circ}$  F, and an AN-F-32 fuel would give a combustible mixture in a tank from  $95^{\circ}$  to  $175^{\circ}$  F. Because the temperature range of  $35^{\circ}$  to  $100^{\circ}$  F is more likely to be encountered than the other ranges discussed, the 1-pound fuel must be considered more hazardous than a 7-pound or AN-F-32 type fuel. The explosive limits of fuels of intermediate volatility are shown in reference 28 and indicate relatively small improvements over the 1-pound fuel.

1421

For commercial operations of manufacture and shipment, the existence of combustible mixtures in tanks does not seem to be an important hazard. Lightning strikes are more likely to cause fires in tanks containing a 1-pound fuel than in tanks containing gasoline. Aside from lightning strikes, no appreciable differences have been reported in the number of fires occurring with low-volatility fuel and with gasoline because static electrical discharges are minimized by proper grounding of equipment and by safe operating procedures.

An example of an item of commerce that has a vapor pressure in the hazardous range is ethyl alcohol. It has a Reid vapor pressure of about 2 pounds per square inch, but is manufactured and shipped in large quantities, apparently without undue difficulty. The shipment and storage of a 1-pound fuel, or fuel of intermediate volatility, might present more of a problem in military operations than in commercial trade.

Penetration of an incendiary bullet into a fuel tank would cause a fire with gasoline but would probably cause an explosion with a 1-pound fuel or AN-F-32. This would apply both to drum storage and to larger tanks including tankers and aircraft carriers. Ships entering combat areas would probably have to provide inert gas in the vapor space above fuels.

The function of whether the handling of fuels of low and intermediate volatility presents an important problem will require analysis by an expert in logistics.

#### Weathering Losses

Fuels with Reid vapor pressures in the region of 5 to 7 pounds per square inch lose appreciable quantities of vapor when stored in vented containers and during transfer. The general order of these losses has been determined by the Sun Oil Company in laboratory experiments that have been conducted to determine the fuel losses that would be encountered in vented containers at sea-level pressure. One sample of fuel was pressurized to a Reid vapor pressure of 6.5 pounds per square inch with n-butane and another sample was pressurized to the same Reid vapor pressure with n-pentane. The fuels were placed in unstoppered quart bottles and were alternately heated and cooled between about 70° and 120° F in approximately a 24-hour cycle. The maximum losses encountered in the tests were 16 percent by volume of the fuel pressurized with n-pentane and 8 percent with n-butane. The lower losses are obtained with n-butane because less n-butane is required to pressurize to 6.5 pounds per square inch.

Such losses represent the maximum that would be encountered during handling or during storage in open containers. Losses during ordinary handling and storage are less than these maximum values.

Aviation gasoline with a maximum Reid vapor pressure of 7 pounds per square inch will give losses similar to those already cited under the same conditions. In the past, however, weathering losses have not been of undue concern to aircraft operators. Undoubtedly such losses can be tolerated for jet fuel if other requirements dictate a fuel of 5- to 7-pounds per square inch Reid vapor pressure. Other things being equal, however, it would be desirable to choose a fuel that would give minimum weathering losses.

1421

#### CONCLUDING REMARKS

The selection of an optimum fuel for gas-turbine powered aircraft involves the consideration of many variables. A number of the variables are briefly considered in this report and a few appear to be of paramount importance.

One important problem at the present time is the matter of fuel loss by high-performance aircraft during climb to high altitudes.

A remedial measure such as fuel cooling on the ground would require a large amount of equipment and would complicate the servicing of aircraft.

Fuel-tank pressurization to prevent all fuel losses might compromise the performance of some types of aircraft. Tank pressurization to 2 pounds per square inch, however, tends to minimize fuel losses and probably would not require additional structural weight. Such tank pressurization might be a reasonable compromise if a volatile fuel were necessary in order to provide the quantities of fuel required for aircraft gas-turbine engines.

The most apparent solution to the fuel-loss problem is the use of a low-volatility fuel, preferably with a Reid vapor pressure of 1 pound per square inch or less. In the light of present knowledge, the use of a low-volatility fuel in gas-turbine engines should present no difficulty insofar as fuel consumption and altitude operational limits are concerned.

In present engines, however, low-volatility fuels are less effective than volatile fuels for starting at high altitudes, or at



low temperatures at sea level. The engine starting problem is under investigation by a number of organizations. The effort on the problem indicates some hope for a solution in the near future.

Less volatile fuels will tend to form somewhat larger carbon deposits than volatile fuels. This should not be a difficulty with most types of fuel and probably can be eliminated by suitable combustor design.

In order to insure maximum safety for combat aircraft, fuel-tank inerting should be provided for use with any fuel.

The quantity of fuel required for turbojets has not been stated. Therefore, it is not possible to accurately estimate the possibility of meeting the required fuel quantities for turbine powered aircraft with a low-vapor-pressure fuel.

Lewis Flight Propulsion Laboratory,  
National Advisory Committee for Aeronautics,  
Cleveland, Ohio.

#### REFERENCES

1. Anon.: Capacity of U.S. Refining Industry is 6,716,000 b/d, API Survey Shows, National Petroleum News, vol. 42, no. 29, July 19, 1950, p. 20.
2. Hardy, J. K., and Bigg, F. J.: Cooling of Fuel in Integral Tanks. Tech. Note Mech. Eng. 43, British R.A.E., Oct. 1949.
3. Huston, Wilber B., Warfield, Calvin N., Stone, Anna Z.: A Study of Skin Temperatures of Conical Bodies in Supersonic Flight. NACA TN 1724, 1948.
4. Tischler, Adelbert O., and Dittrich, Ralph T.: Fuel Investigation in a Tubular-Type Combustor of a Turbojet Engine at Simulated Altitude Conditions. NACA RM E7F12, 1947.
5. Dittrich, Ralph T., and Jackson, Joseph L.: Altitude Performance of AN-F-58 fuels in J33-A-21 Single Combustor. NACA RM E8L24, 1949.
6. Wilsted, H. D., and Armstrong, J. C.: Comparison of Performance of AN-F-58 and AN-F-32 Fuels in J33-A-23 Turbojet Engine. NACA RM E8K24, 1949.

7. Meyer, Carl L.: Altitude-Wind-Tunnel Investigation of AN-F-58 Fuel in Experimental Version of J47 Turbojet Engine. NACA RM E8L13, 1949.
8. Acker, Loren, W., and Kleinknecht, Kenneth S.: Comparison of Flight Performance of AN-F-58 and AN-F-32 Fuels in J35 Turbojet Engine. NACA RM E8L02, 1949.
9. Dowman, Harry W., and Younger, George G.: Comparison of Performance of AN-F-58 Fuel and Gasoline in J34-WE-22 Turbojet Engine. NACA RM E8L10a, 1949.
10. Zettle, Eugene V., and Mark, Herman: Simulated Altitude Performance of Two Annular Combustors with Continuous Axial Openings for Admission of Primary Air. NACA RM E50E18a, 1950.
11. Dittrich, Ralph T.: Combustion-Efficiency Investigation of Special Fuels in Single Tubular-Type Combustor at Simulated Altitude Conditions. NACA RM E7F11, 1947.
12. Bolz, Ray E., and Meigs, John B.: Fuel Tests on an I-16 Jet-Propulsion Engine at Static Sea-Level Conditions. NACA RM E7B01, 1947.
13. Zettle, Eugene V., Bolz, Ray E., and Dittrich, R. T.: Effect of Fuel on Performance of a Single Combustor of an I-16 Turbojet Engine at Simulated Altitude Conditions. NACA RM E7A24, 1947.
14. McCafferty, Richard J.: Effect of Fuels and Fuel-Nozzle Characteristics on Performance of an Annular Combustor at Simulated Altitude Conditions. NACA RM E8C02a, 1948.
15. Wear, Jerrold D., and Jonash, Edmund R.: Combustion-Efficiency and Altitude-Limit Investigations of Five Fuels in an Annular Turbojet Combustor. NACA RM E7L30, 1948.
16. Olson, Walter T., Childs, J. Howard, and Jonash, Edmund R.: Turbojet Combustor Efficiency at High Altitudes. NACA RM E50I07, 1950.
17. Dittrich, Ralph T.: Effects of Fuel-Nozzle Carbon Deposition on Combustion Efficiency of Single Tubular-Type, Reverse-Flow, Turbojet Combustor at Simulated Altitude Conditions. NACA TN 1618, 1948.

- 1421
18. Zettle, Eugene, V., and Cook, William P.: Performance Investigation of Can-Type Combustor. I - Instrumentation, Altitude Operational Limits, and Combustion Efficiency. NACA RM E8F17, 1948.
  19. Rayle, Warren D., and Douglass, Howard W.: Investigation of Ignition Characteristics of AN-F-32 and Two AN-F-58a Fuels in Single Can-Type Turbojet Combustor. NACA RM E50H16a
  20. Wilsted, H. D., and Armstrong, J. C.: Effect of Fuel Volatility on Altitude Starting Limits of a Turbojet Engine. NACA RM E50G10, 1950.
  21. Wear, Jerrold D., and Jonash, Edmund R.: Carbon Deposition of 19 Fuels in an Annular Turbojet Combustor. NACA RM E8K22, 1949.
  22. Wear, Jerrold D., and Douglass, Howard W.: Carbon Deposition from AN-F-58 Fuels in a J33 Single Combustor. NACA RM E9D06, 1949.
  23. Warfield, Calvin N.: Tentative Tables for the Properties of the Upper Atmosphere. NACA TN 1200, 1947.
  24. Sweeney, W. J., Blackwood, A. J., and Guyer, W. R. F.: Report on Aviation Gas Turbine Fuels. Paper presented at Nat. Aircraft Propulsion Meeting I.A.S. (Cleveland), March 28, 1947.
  25. Cleveland Laboratory Aircraft Fire Research Panel: Preliminary Survey of the Aircraft Fire Problem. NACA RM E8B18, 1948.
  26. Anon.: Standard Method of Test for Autogenous Ignition Temperatures of Petroleum Products. (Adopted 1930.) A.S.T.M. Designation: D 286-30. A.S.T.M. Standards on Petroleum Products and Lubricants, Sept. 1941, pp. 37-38.
  27. Anon.: Standard Method of Test for Flash Point by Means of the Tag Closed Tester. (Adopted 1919; rev. 1921, 1936.) A.S.T.M. Designation: D 56-36. 1939 Book of A.S.T.M. Standards, Pt. II, Nonmetallic Materials, pp. 742-745.
  28. Anon.: CRC Handbook, Coordinating Res. Council, Inc., 1946, p. 263.

TABLE I - SPECIFICATIONS AND ANALYSIS OF FUELS

	SPECIFICATIONS		ANALYSIS		
	AN-F-58A	AN-F-32A	AN-F-58	I-LB R.V.P.	AN-F-32
	MIL-F-5624	MIL-F-5616	(JP-3)		(JP-1)
A.S.T.M. DISTILLATION					
D 86-46, °F					
I.B.P.			110	200	336
% EVAPORATED					
5			135	226	350
10		410 (MAX.)	157	248	356
20			192	272	360
30			230	300	365
40			272	329	370
50			314	356	375
60			351	386	380
70			388	412	387
80			427	445	394
90	400 (MIN.)	490 (MAX.)	473	481	405
F.B.P.	572 (MAX.)	600 (MAX.)	560	564	446
RESIDUE, %	1.5 (MAX.)	1.5 (MAX.)	1.0	1.4	1.0
LOSS, %	1.5 (MAX.)	1.5 (MAX.)	1.0	0	1.0

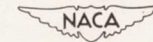

TABLE I - SPECIFICATIONS AND ANALYSIS OF FUELS - Concluded

	SPECIFICATIONS		ANALYSIS		
	AN-F-58A MIL-F-5624	AN-F-32A MIL-F-5616	AN-F-58 (JP-3)	I-LB R.V.P.	AN-F-32 (JP-1)
FREEZING POINT, °F	-76(MAX)	-76 (MAX.)	< -76	< -76	
ACCELERATED GUM (MG/100 ML)	20.0 (MAX)	8.0 (MAX.)	2.9	16	0.0
AIR JET RESIDUE (MG/100 ML)	10 (MAX)	5 (MAX.)	2.6	5	1.0
SULFUR (% WT)	0.20 (MAX)	0.58 (MAX)	0.03	0.056	0.02
AROMATICS (% VOL)	25 (MAX)	20 (MAX)			
SILICA GEL			19	24	15
SPECIFIC GRAVITY	0.728 <sup>TO</sup> 0.802	0.850 (MAX)	0.769	0.801	0.831
VISCOSITY (CSTKS AT -40°F)		10.0 (MAX)	2.67	5.71	
BROMINE NUMBER	30.0 (MAX)	3.0 (MAX)	13.8	6.7	
R.V.P. (LB/SQ IN.)	5-7		5.4	1.0	
H/C RATIO			0.163	0.155	0.154
NET HEAT OF COMB. (BTU/LB)		18,400 (MIN)			
			18,640	18,530	18,400
CORROSION (Cu STRIP)	NONE	NONE			

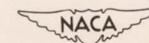
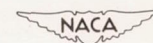
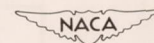

TABLE II - INFLAMMABILITY CHARACTERISTICS OF FUELS

FUEL	FLASH POINT (°F)	SPONTANEOUS IGNITION TEMPERATURE, °F
AN-F-48 (GASOLINE)	-20	845
AN-F-32 (JP-1)	120	480
AN-F-58 (5.4-R.V.P.)	-17	493
4-LB R.V.P.	-5	493
1-LB R.V.P.	40	484





## I. FUEL AVAILABILITY

## II. AIRCRAFT RANGE

- A. Heat Energy of Fuel
- B. Vapor and Surging Losses
  - (1) Fuel tank pressurization
  - (2) Fuel cooling
- C. Aerodynamic Heating
- D. Combustion Efficiency
  - (1) Fuel injection

## III. AIRCRAFT RELIABILITY

- A. Altitude Operational Limits
- B. Altitude Starting
  - (1) Single combustor
  - (2) Full-scale engine
- C. Carbon Deposits
- D. Fuel Pumping
- E. Physical and Chemical Properties
  - (1) Freezing point
  - (2) Ice formation
  - (3) Corrosion and rubber swell
  - (4) Gum

## IV. AIRCRAFT SAFETY

- A. Fire
  - (1) Flame velocity
- B. Combustible Mixtures in Fuel Tanks

## V. LOGISTICS

- A. Fuel Storage and Shipment
- B. Weathering Losses

Figure 1. - Factors in selection of turbine fuels.

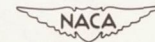
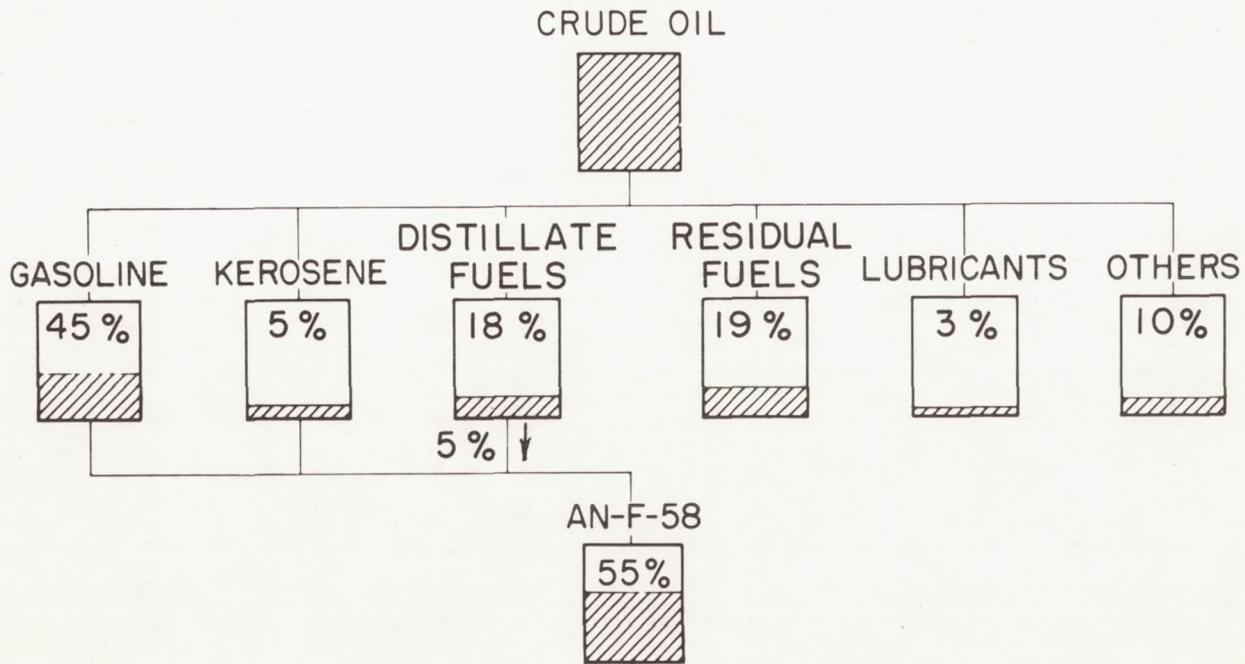

Figure 2. - Availability of fuels from petroleum.



1421

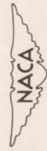
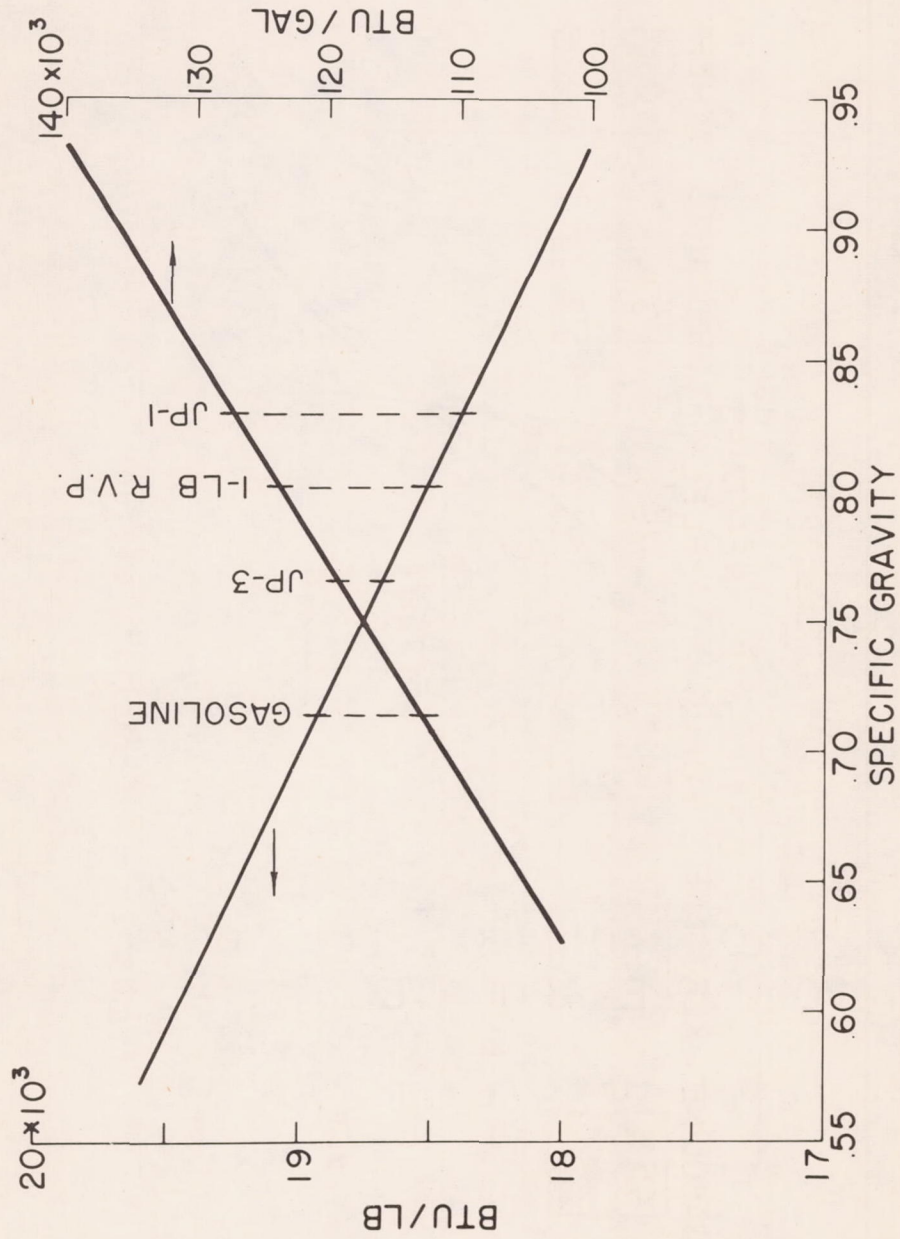

Figure 3. - Heating values of petroleum fractions.

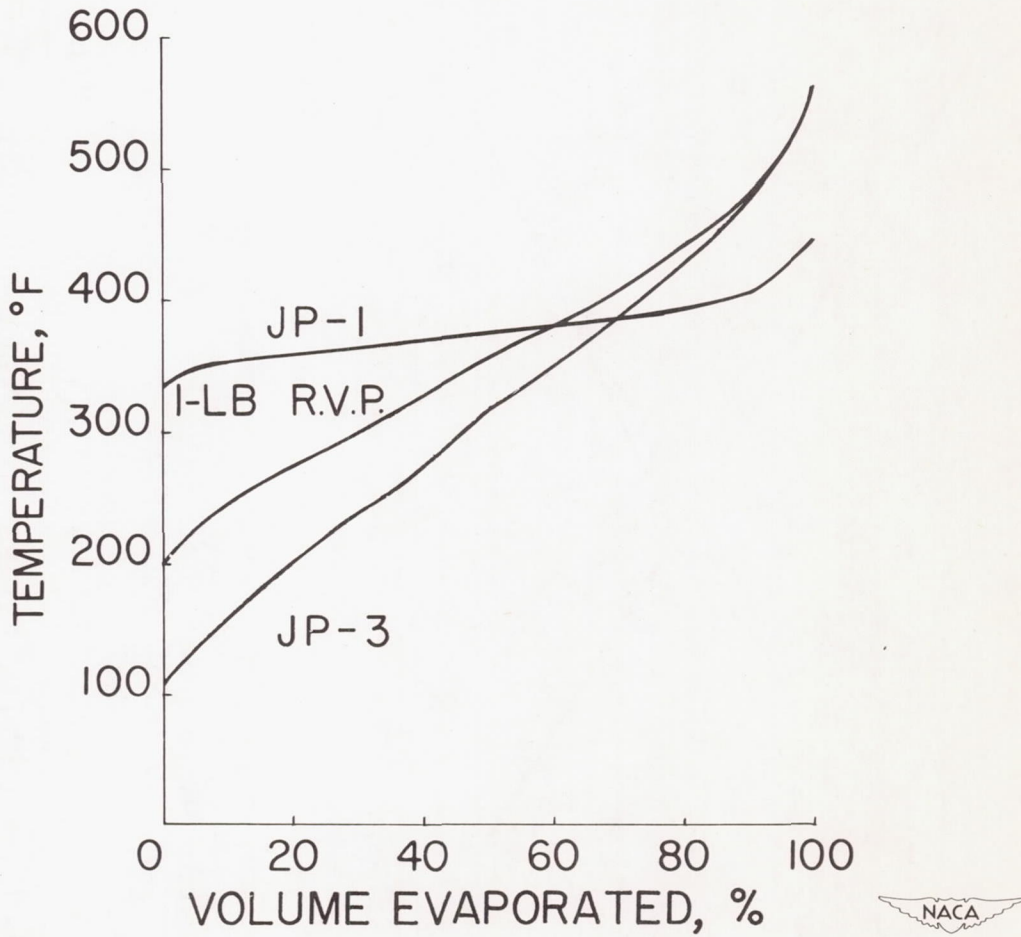

Figure 4. - Distillation curves for three fuels.

1421

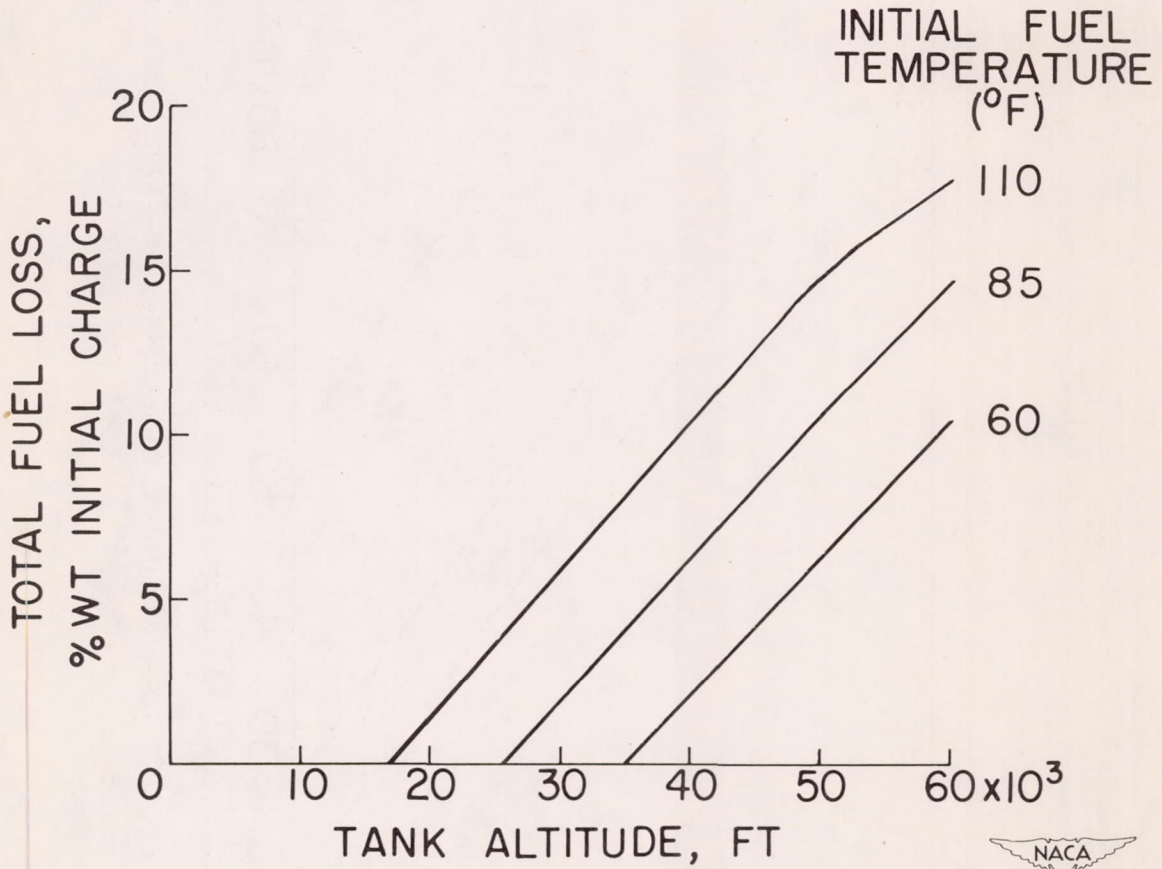
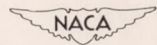

Figure 5. - Effect of altitude on fuel loss.  
Rate of climb, 3000 feet per minute; no  
slugging loss indicated; Reid vapor  
pressure, 7.35 pounds per square inch.



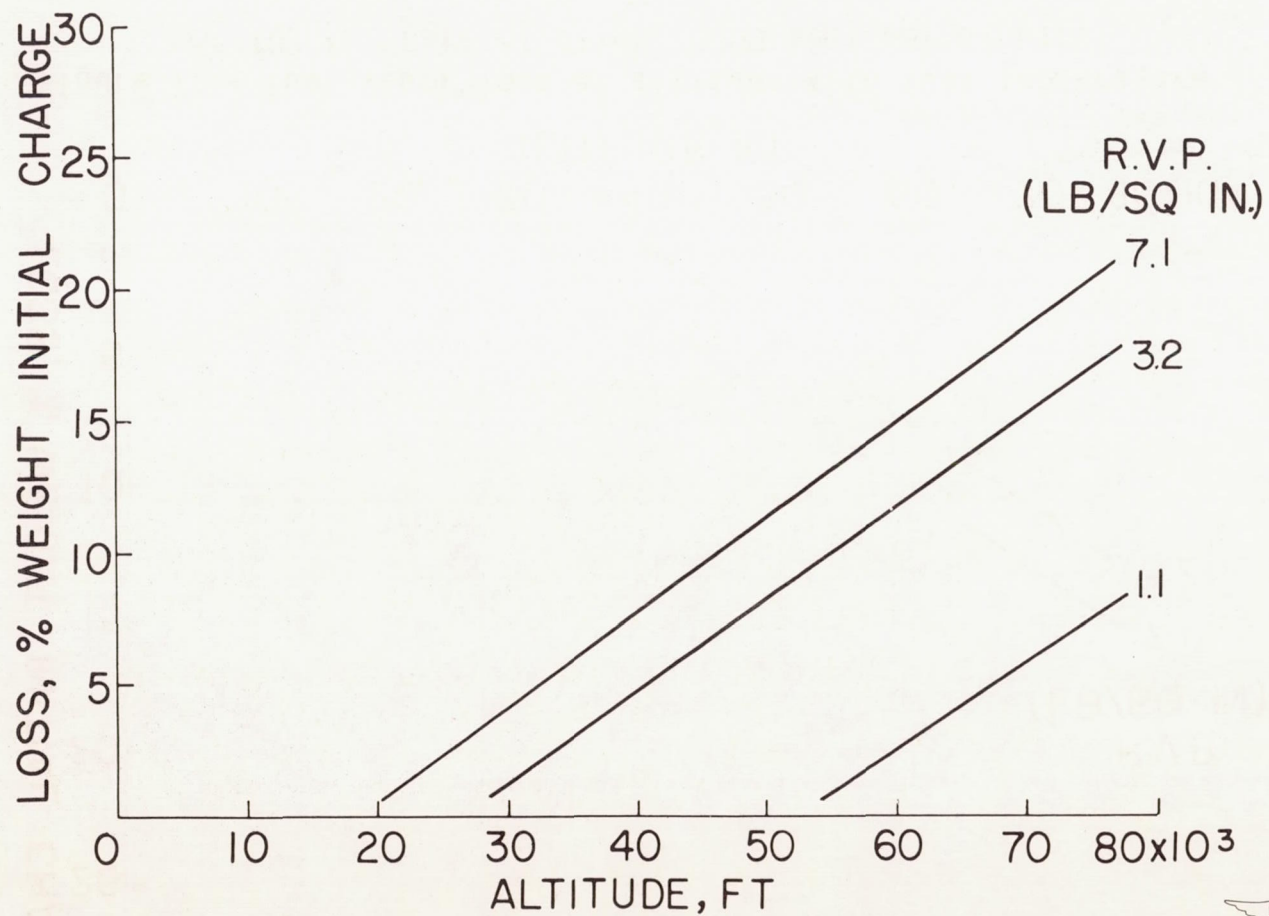
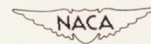

Figure 6. - Fuel vapor loss at altitude with fuel temperature of 100° F. Rate of climb, 3000 feet per minute.



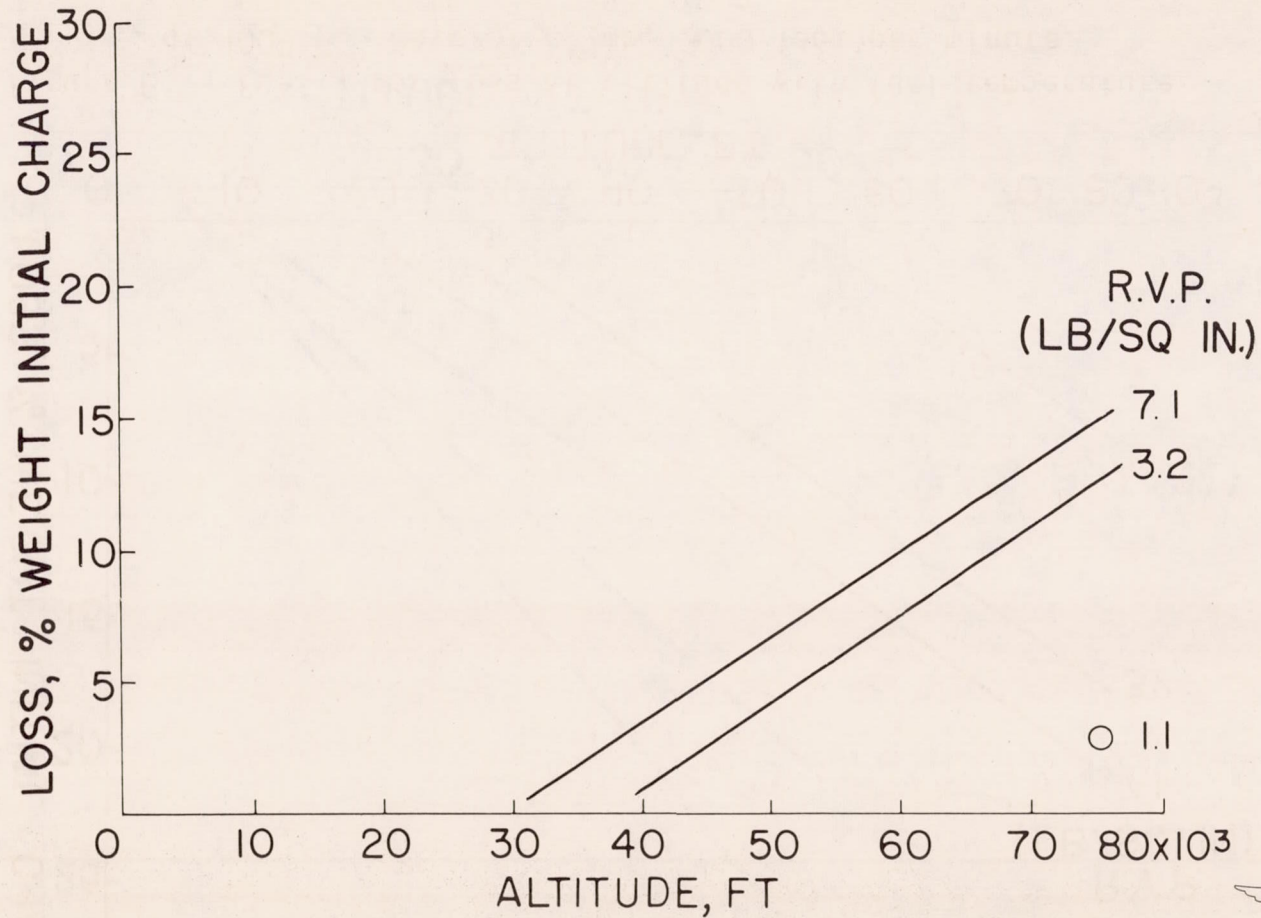
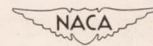

Figure 7. - Fuel vapor loss at altitude with fuel temperature of 70° F. Rate of climb, 3000 feet per minute.



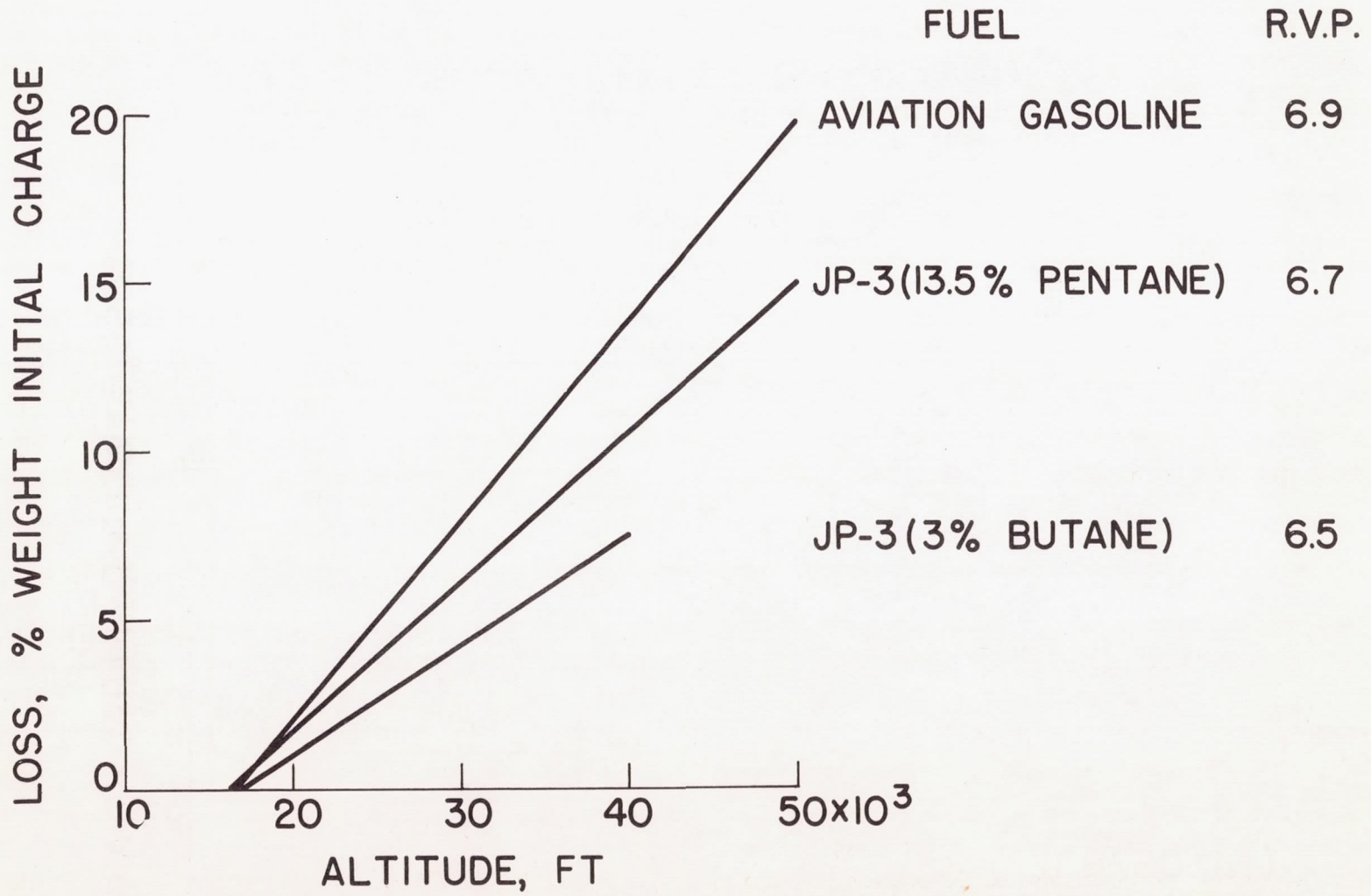

Figure 8. - Effect of fuel composition on fuel vapor loss. Initial temperature, 110° F; rate of climb, 3000 feet per minute.



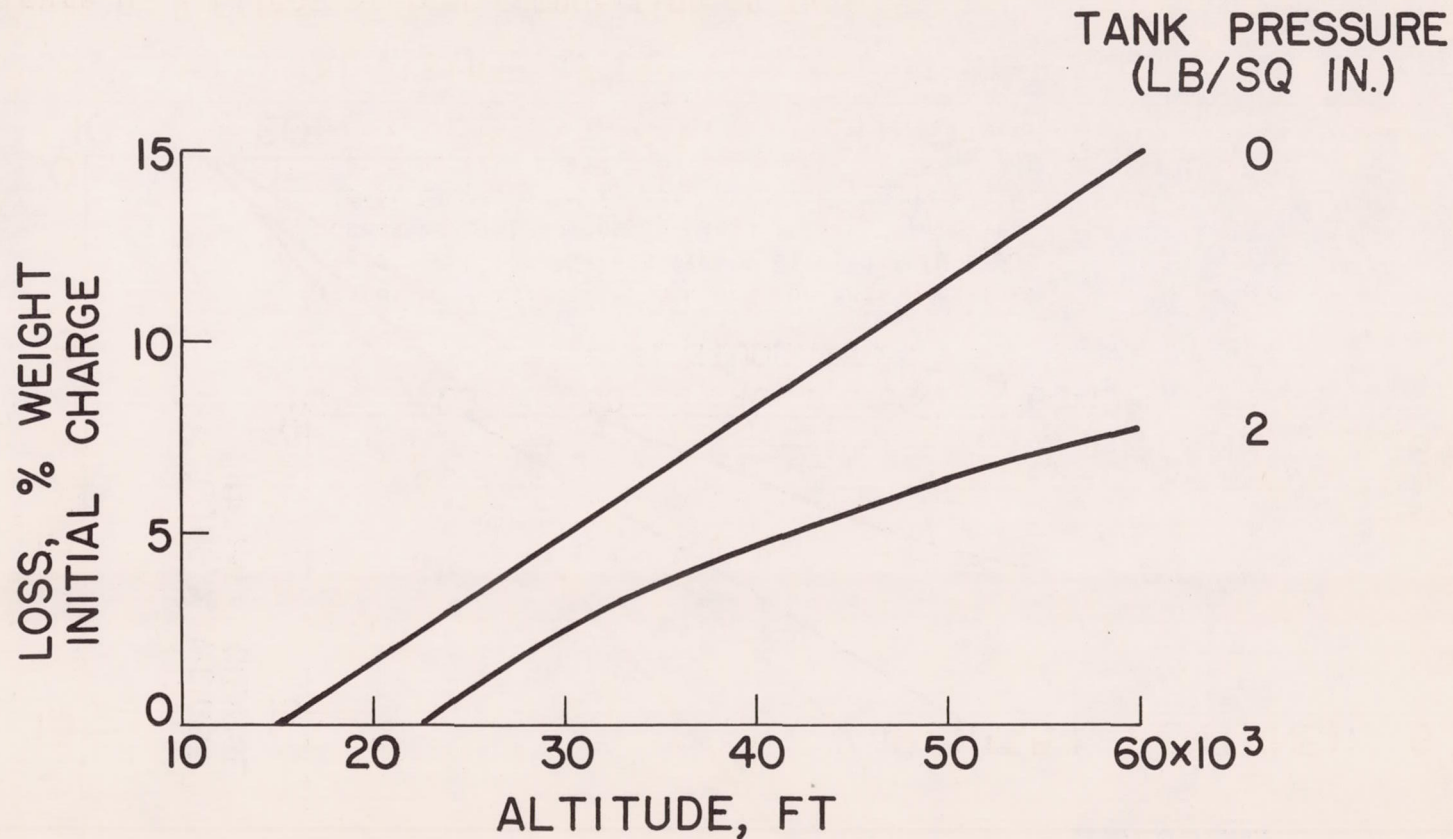
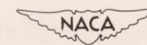

Figure 9. - Effect of tank pressurization on fuel vapor loss for AN-F-58 type fuel with Reid vapor pressure of 7 pounds per square inch. Initial temperature, 110° F; rate of climb, 3000 feet per minute.



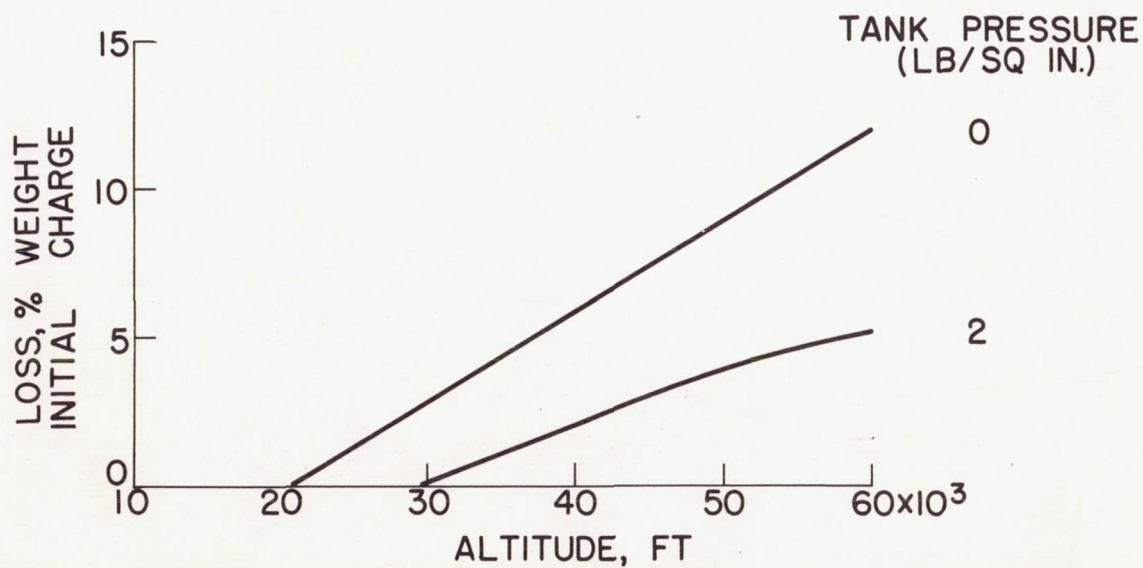
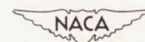

Figure 10. - Effect of tank pressurization on fuel vapor loss for AN-F-58 type fuel with Reid vapor pressure of 5 pounds per square inch. Initial temperature, 110° F; rate of climb, 3000 feet per minute.





1421

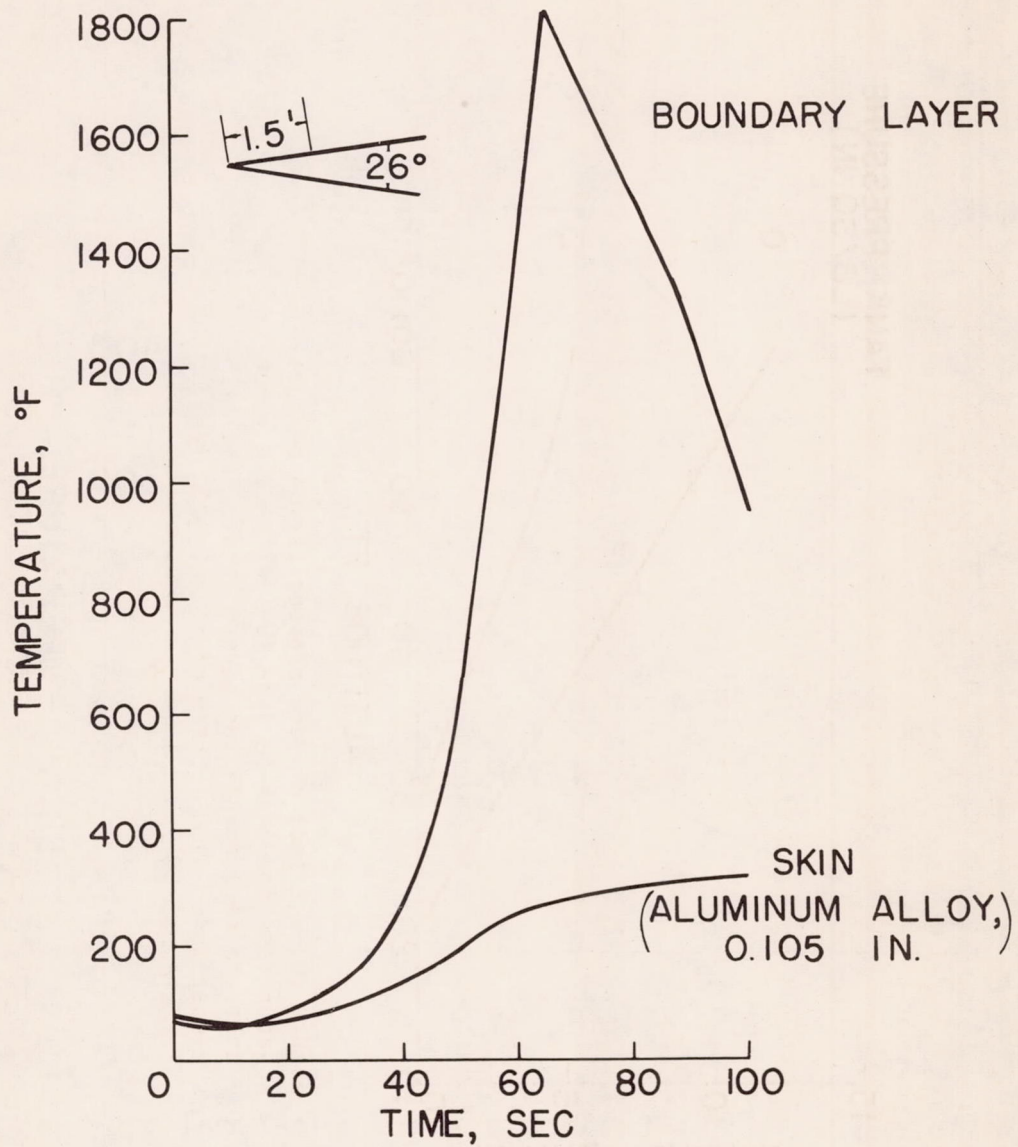
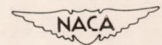

Figure 11. - Time-temperature history for V-2 missile flight.



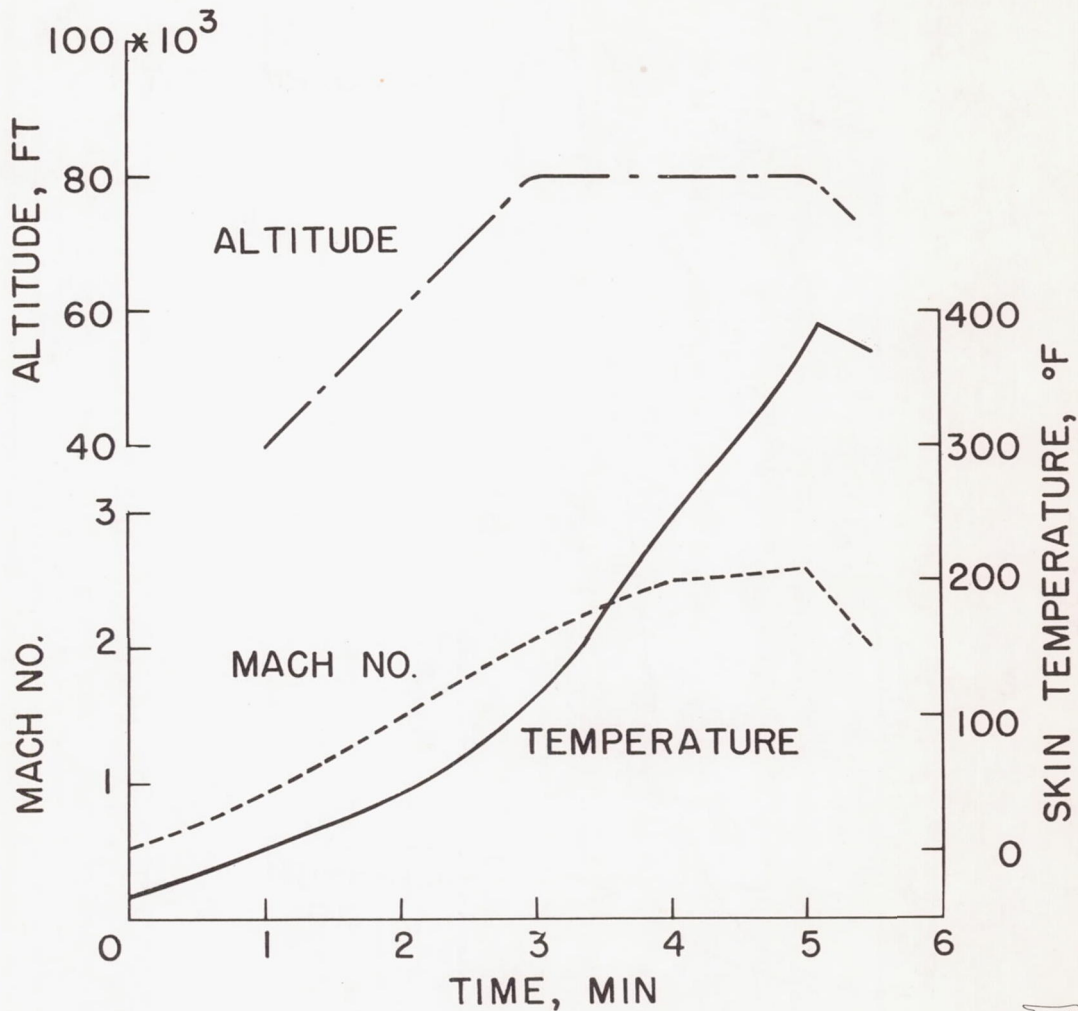

Figure 12. - Skin temperature for supersonic airplane 1 foot from conical nose of  $30^\circ$  included angle for 0.061-inch aluminum alloy 24S-T.



1421

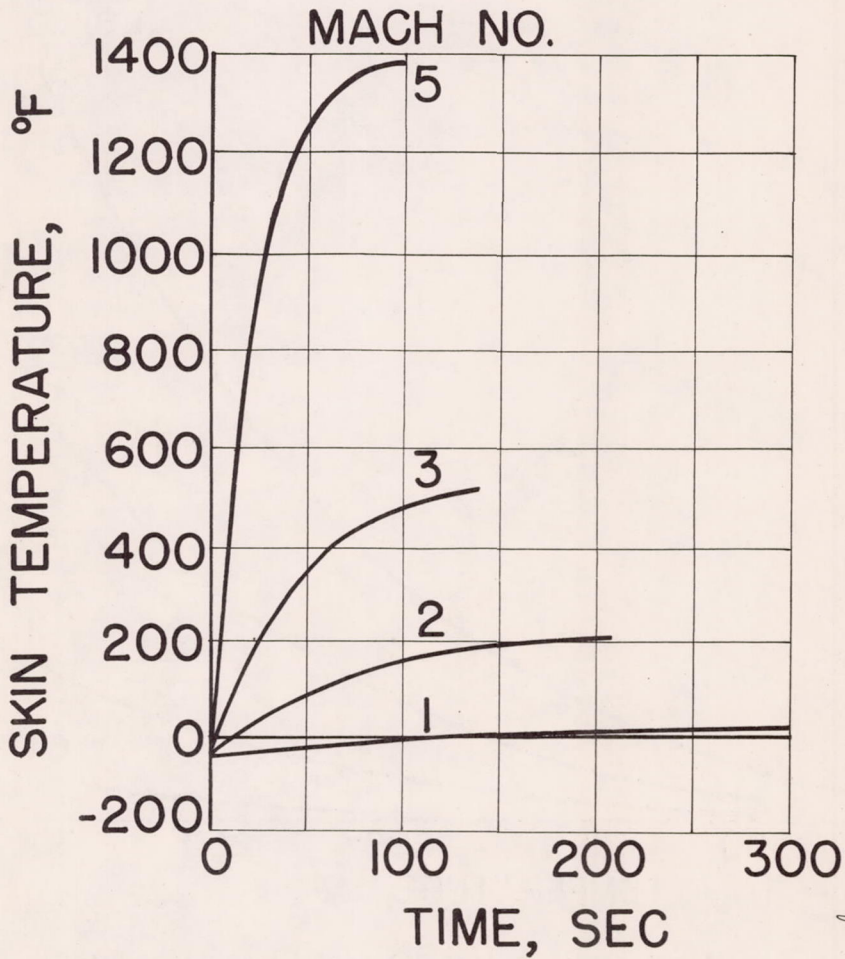

Figure 13. - Skin temperature of a missile at 80,000-foot altitude.

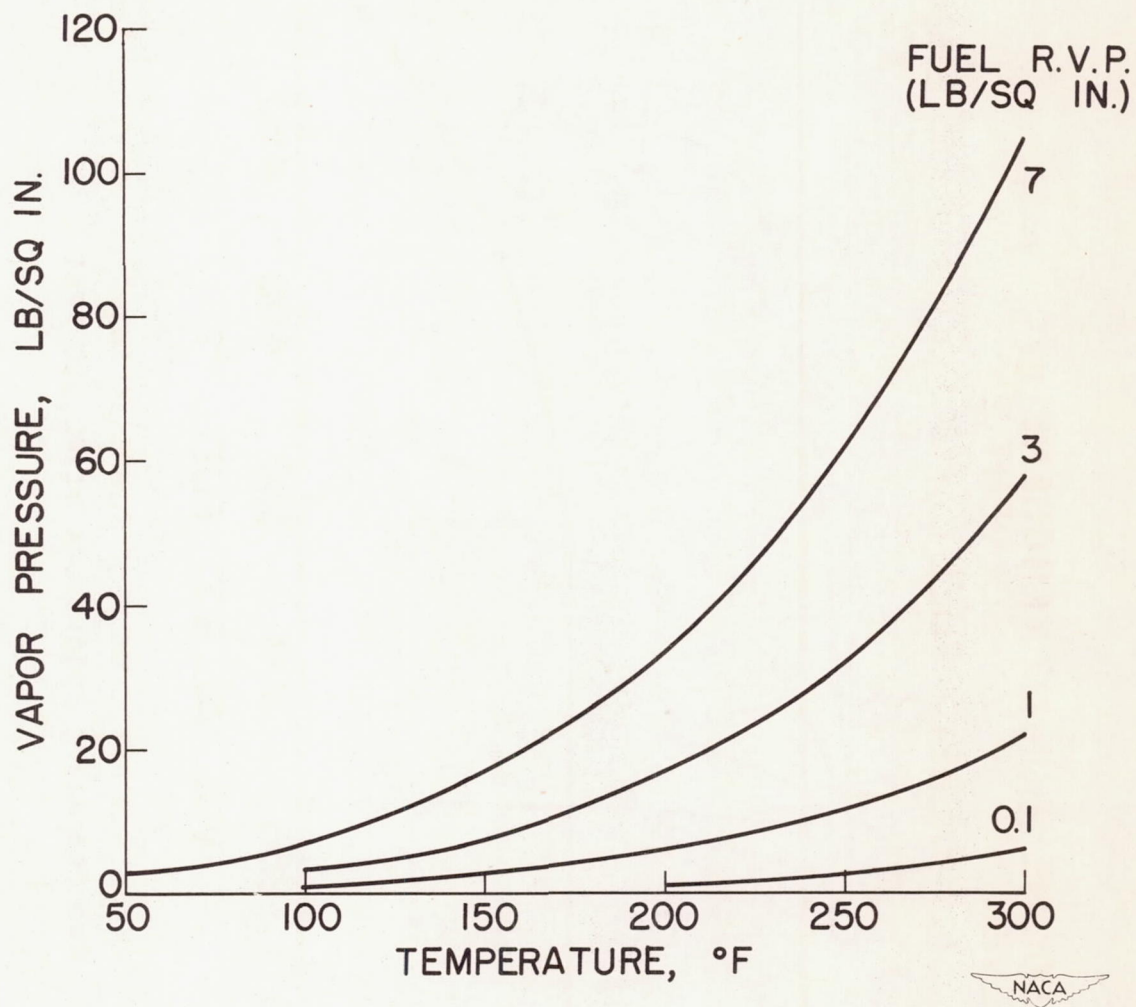

Figure 14. - Effect of temperature on fuel vapor pressure.

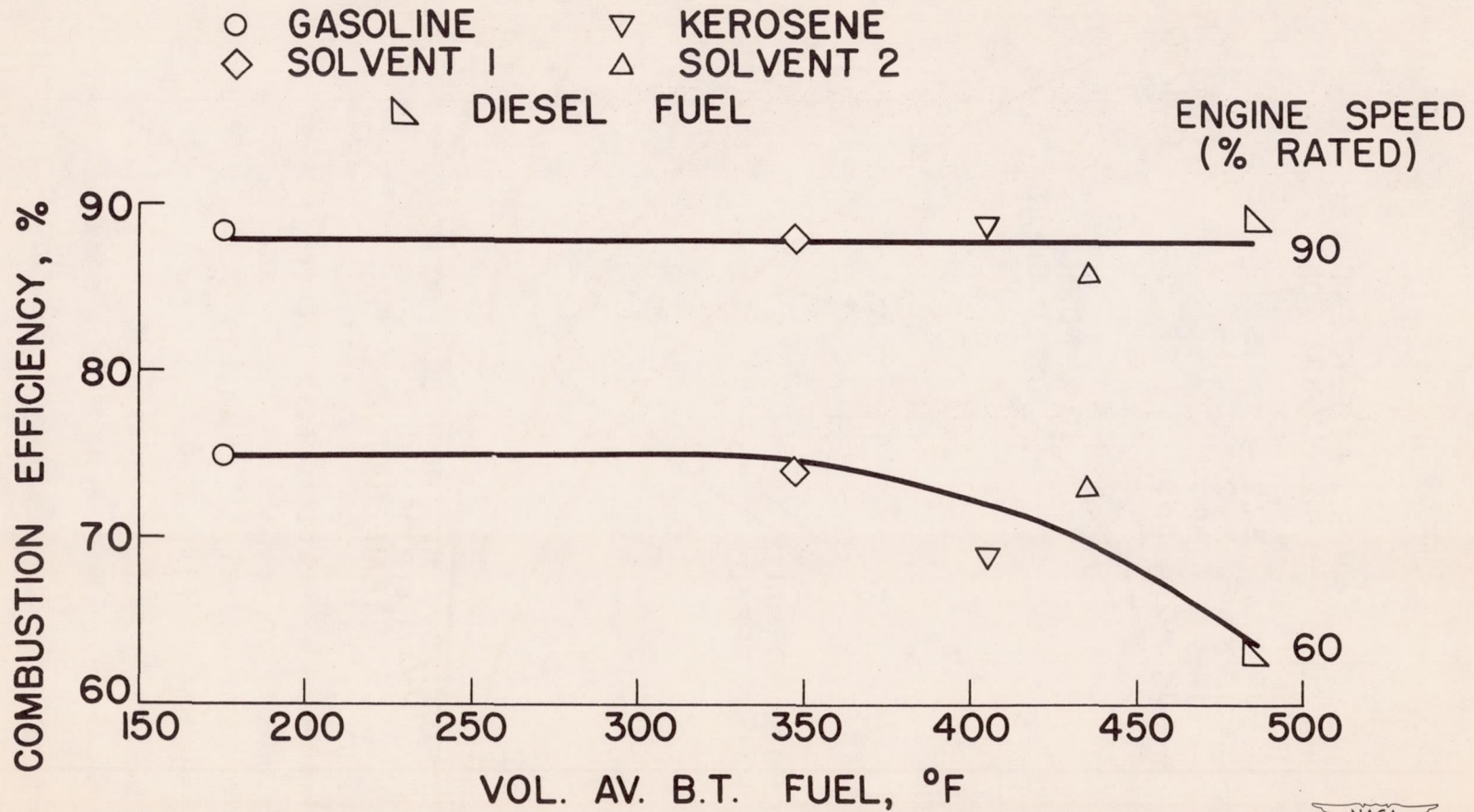
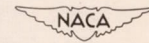
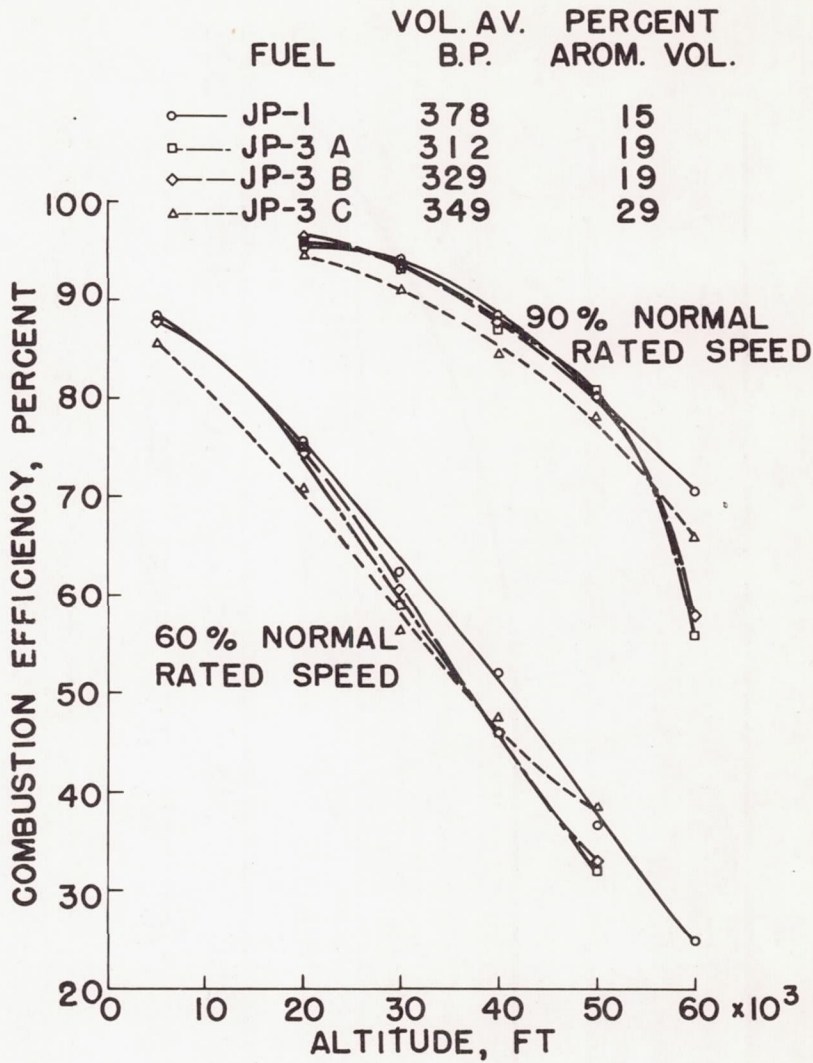

Figure 15. - Combustion efficiency of fuels in tubular combustor for two operating conditions at 40,000 feet.





1421

Figure 16. - Variation of combustion efficiency with altitude in tubular combustor for four fuels at 60- and 90-percent normal rated engine speed. Mach number, 0.6.

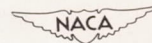

1421

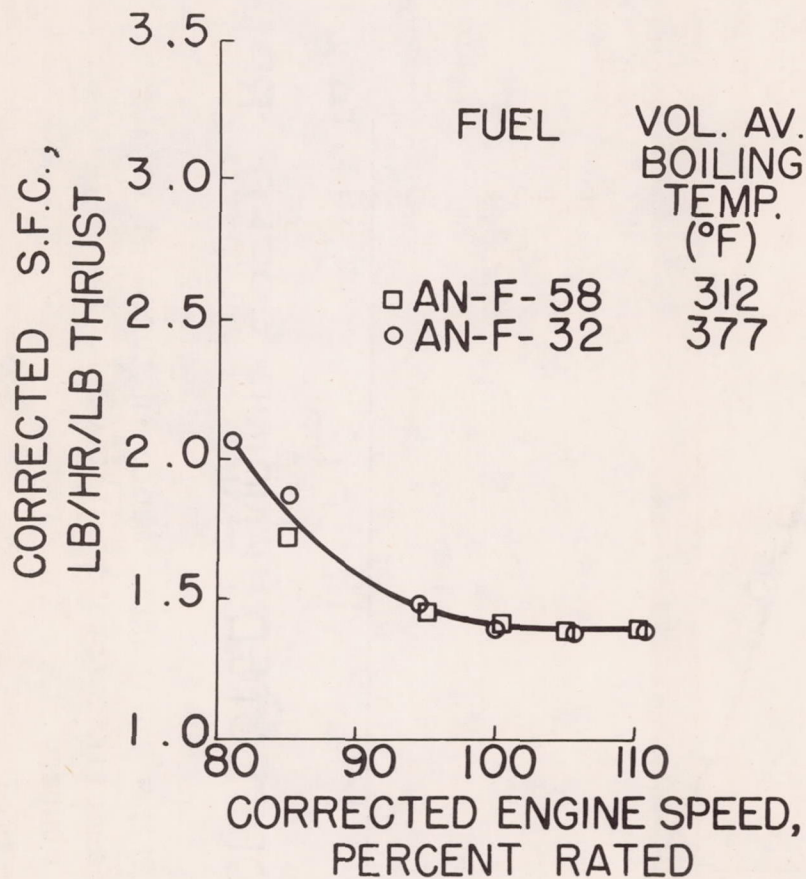
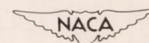

Figure 17. - Fuel performance in turbojet engine with tubular combustors. Mach number, 0.6; altitude, 30,000 feet.



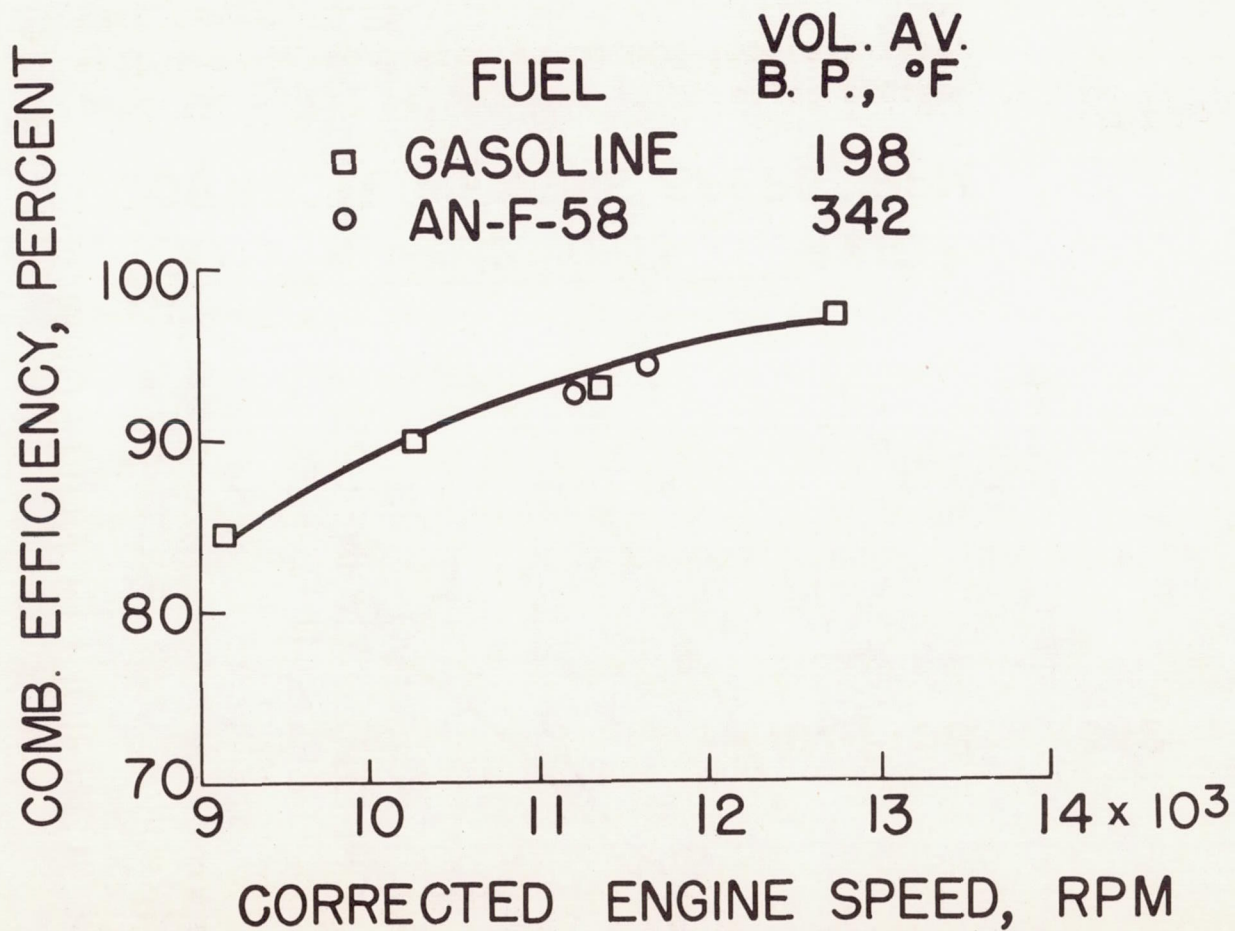
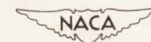

Figure 18. - Fuel performance in turbojet engine with annular combustor at 5000-foot altitude. Mach number, 0.





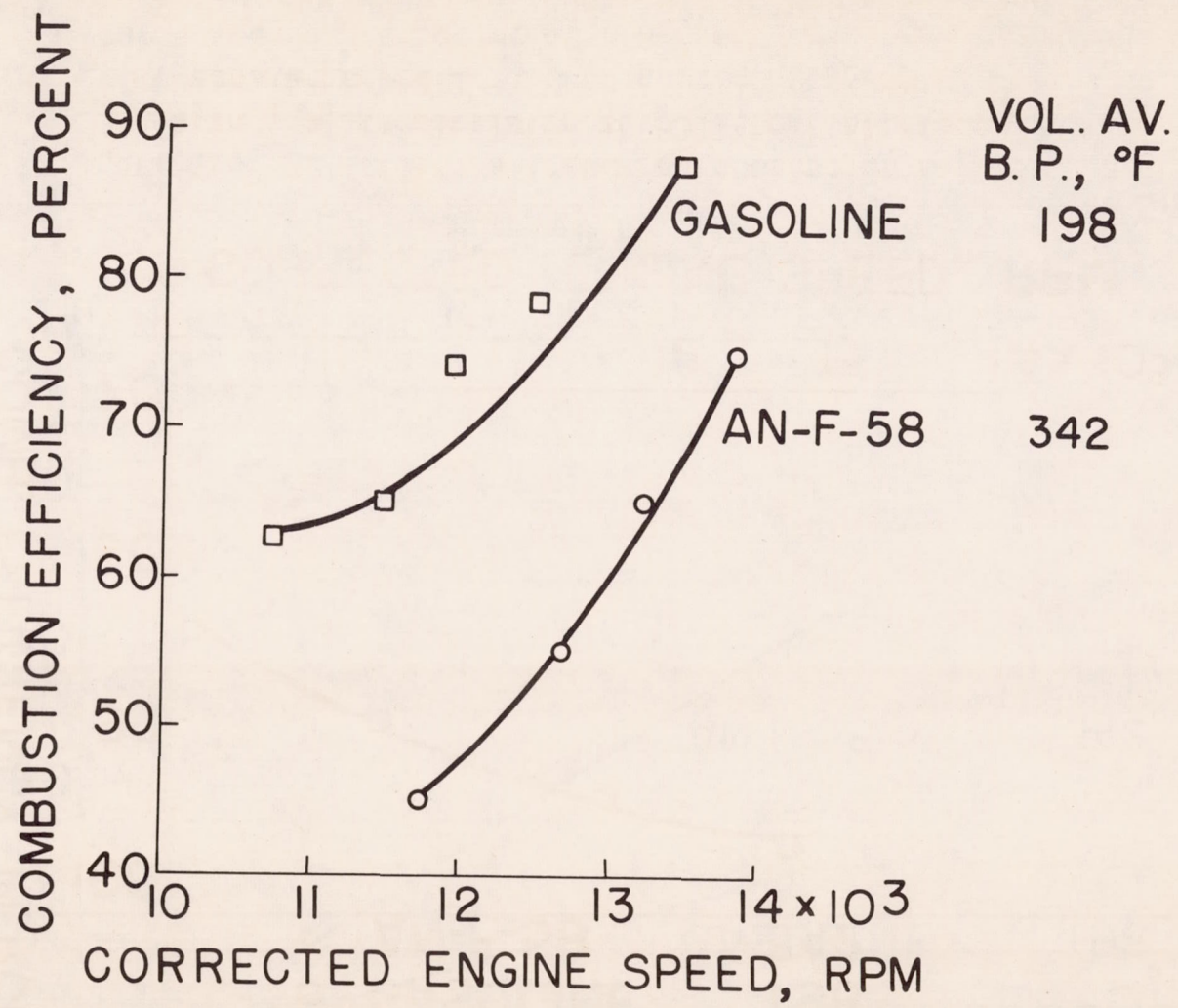
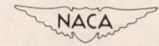

Figure 19. - Fuel performance in turbojet engine with annular combustor at 50,000-foot altitude. Mach number, 0.85.



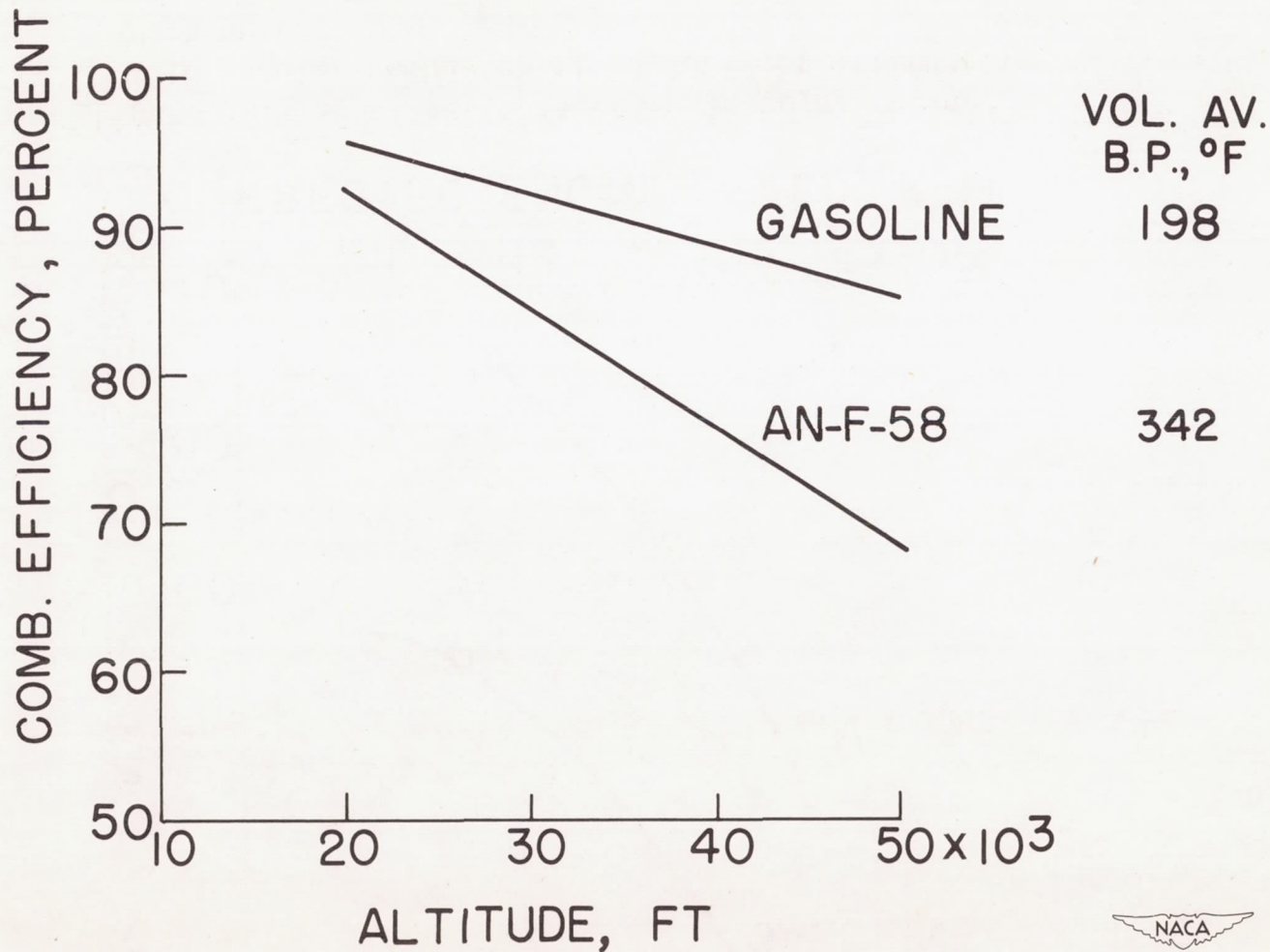
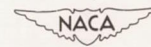

Figure 20. - Effect of altitude on combustion efficiency of two fuels in turbojet engine with annular combustor. Mach number, 0.85; corrected engine speed, 13,500 rpm.



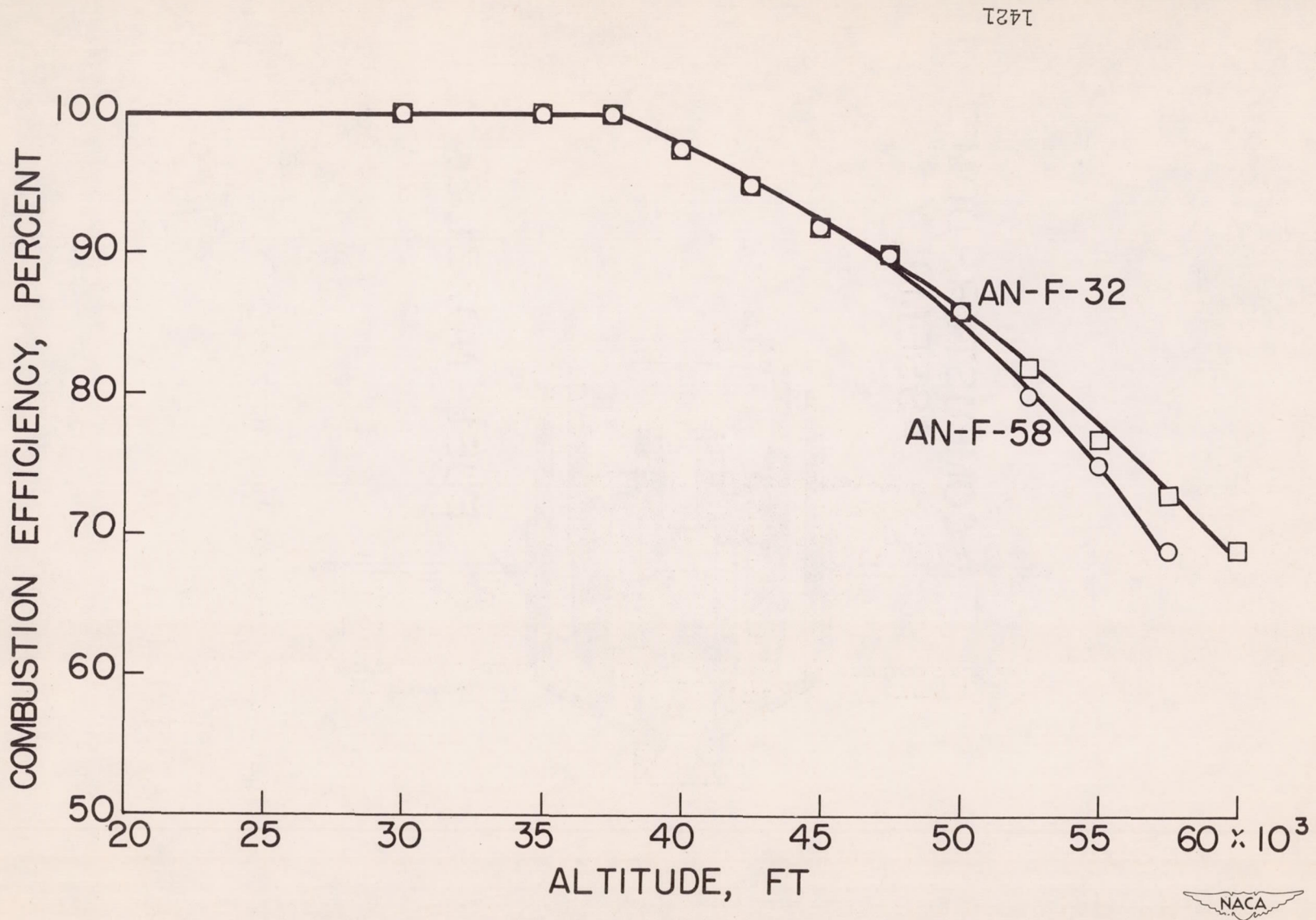

Figure 21. - Combustion efficiency of two fuels in a one-fourth segment of annular combustor at 90-percent rated engine speed.

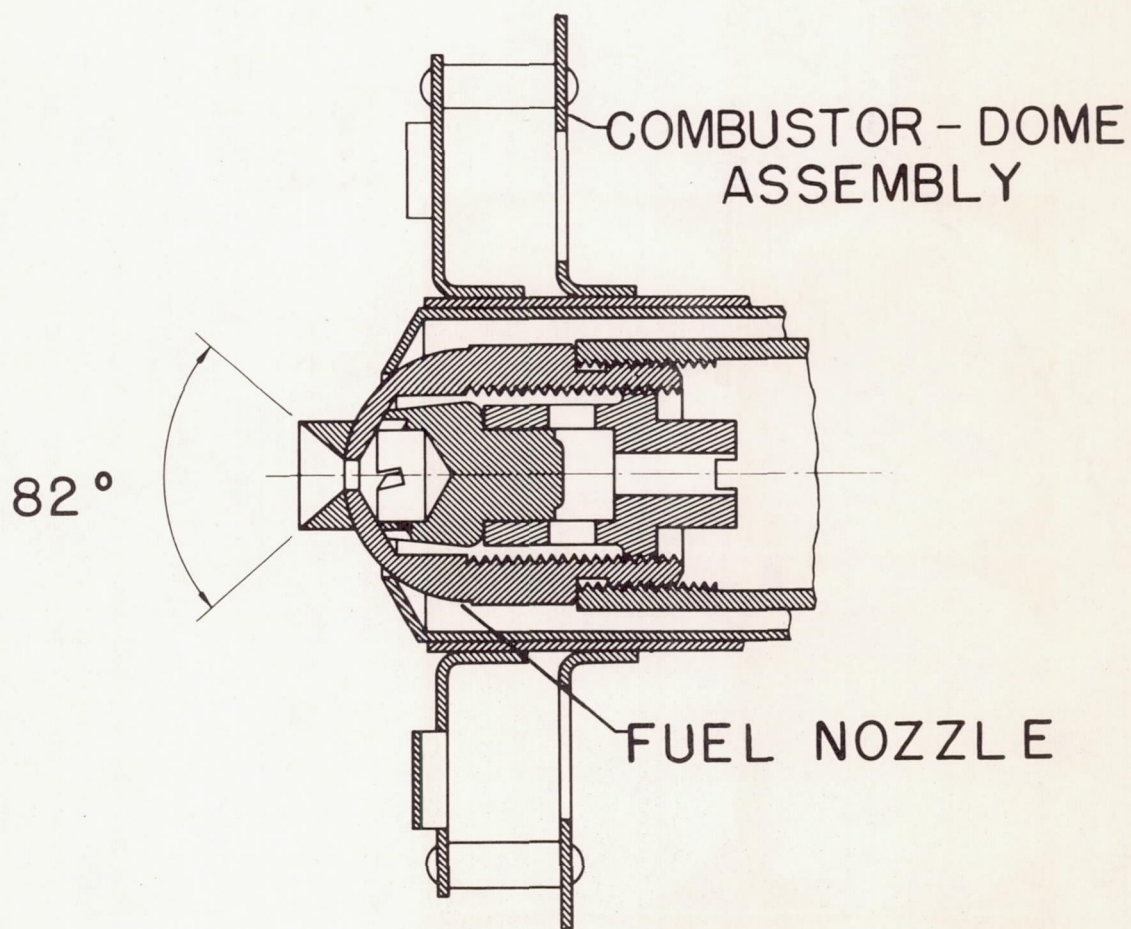

Figure 22. - Flared fuel nozzle.



ORIGINAL  
NOZZLEMODIFIED  
NOZZLE

  
C - 26 489
20  
240  
883  
35FUEL FLOW, LB/HR  
FUEL PRESSURE,  
LB/SQ IN. GAGE

Figure 23. - Fuel sprays for two fuel-nozzle designs.



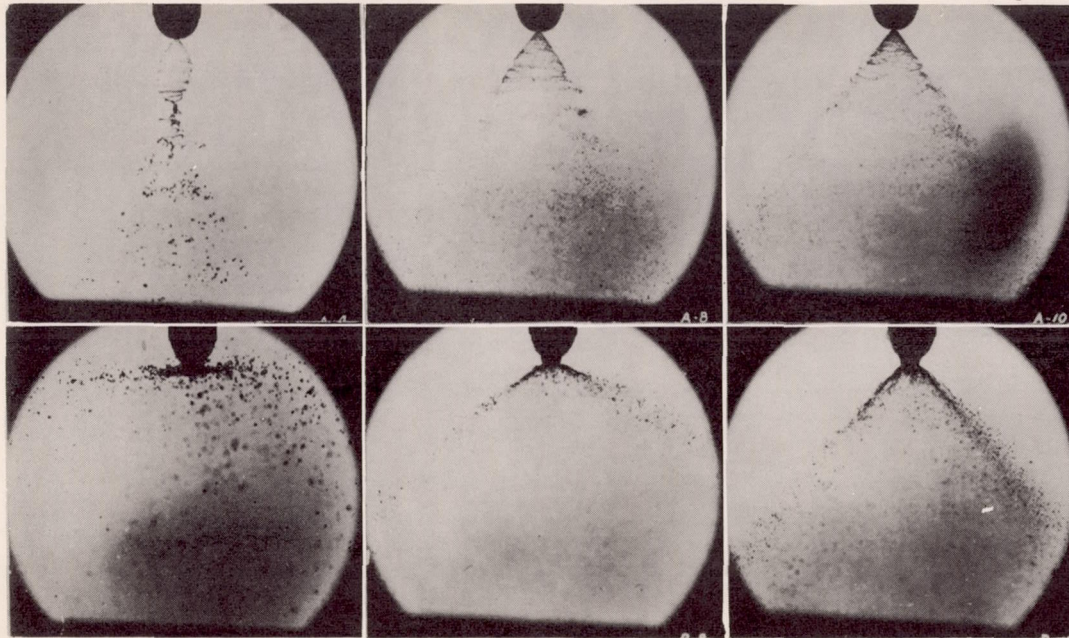
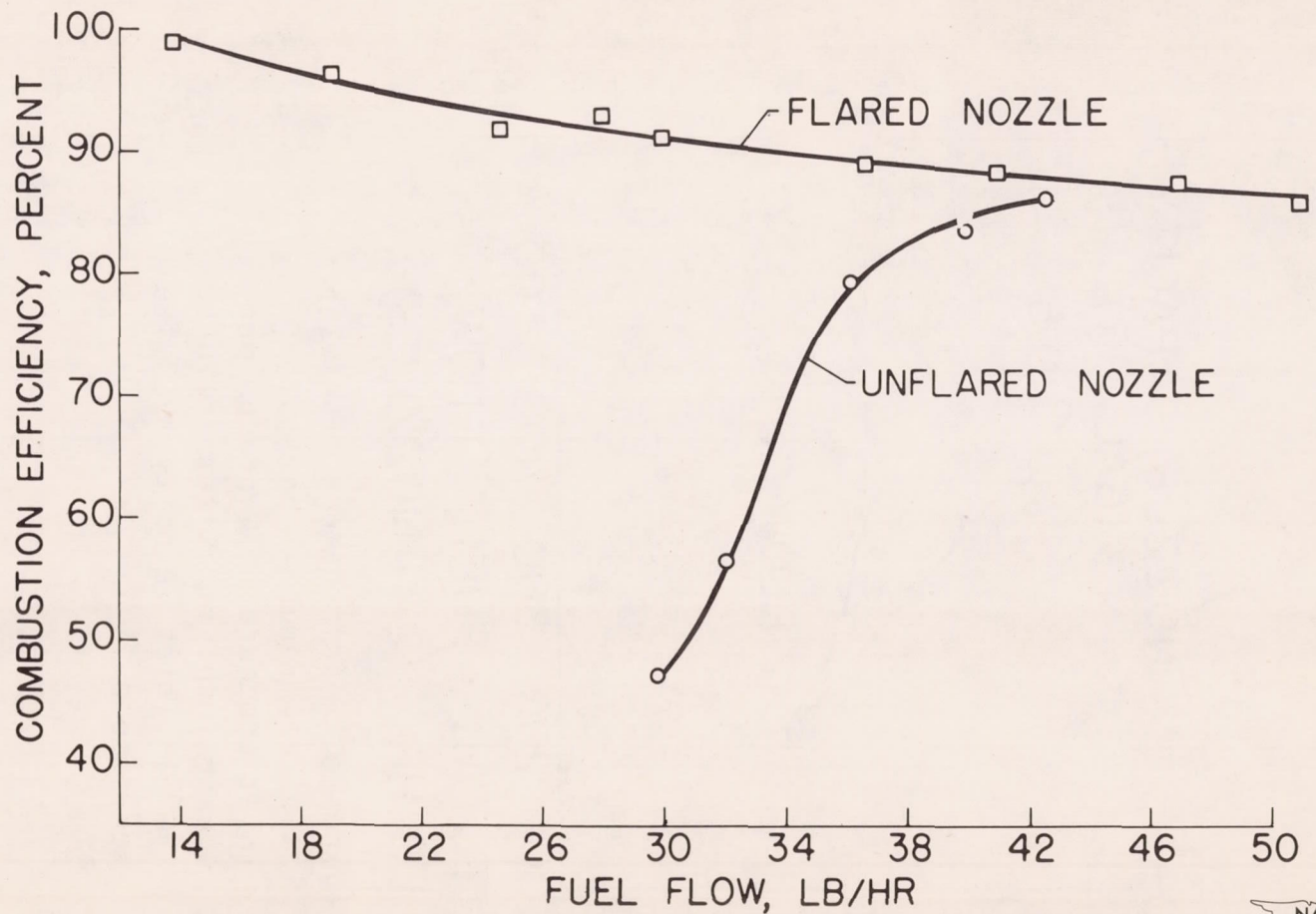
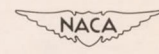

Figure 24. - Effect of fuel-nozzle design on performance.  
 Fuel, kerosene; altitude, 45,000 feet; 100-percent  
 rated engine speed; tubular combustor.



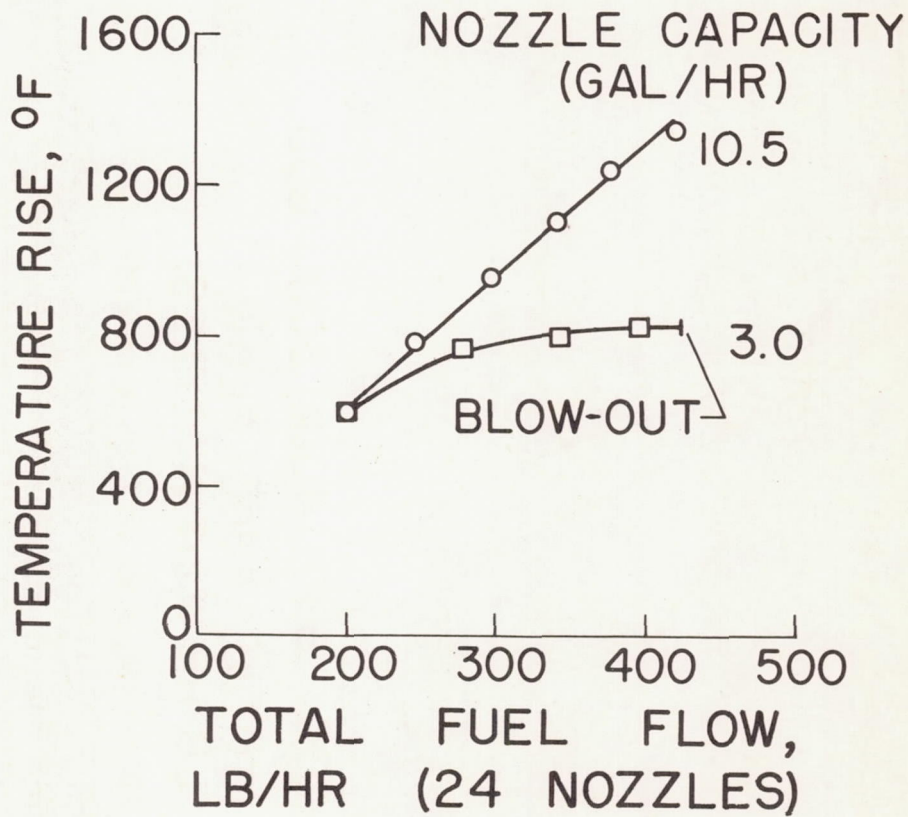
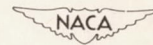

Figure 25. - Temperature rise with gasoline. Annular combustor; inlet pressure, 9.2 pounds per square inch; inlet temperature, 240° F; inlet velocity, 200 feet per second.





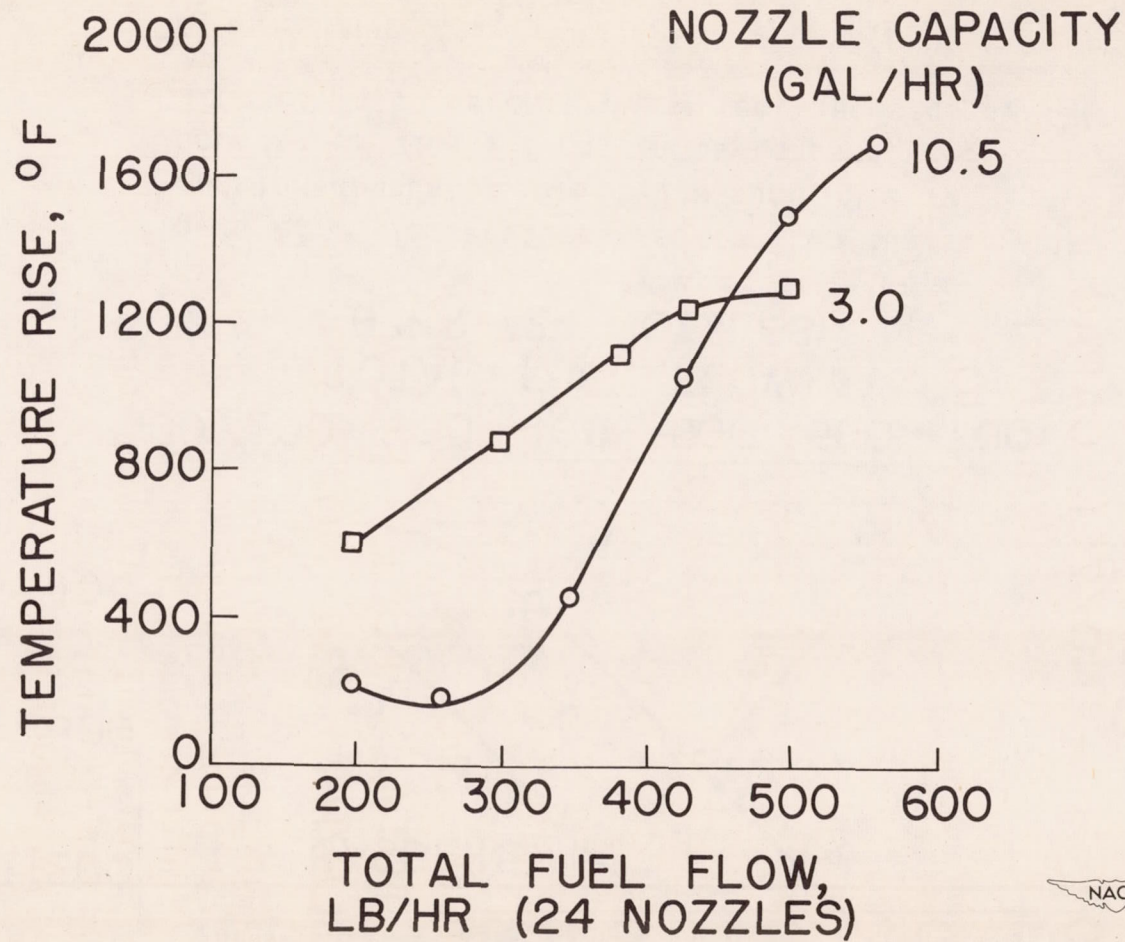
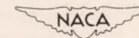

Figure 26. - Temperature rise with diesel oil.  
Annular combustor; inlet pressure, 9.2 pounds  
per square inch; inlet temperature, 240° F;  
inlet velocity, 200 feet per second.



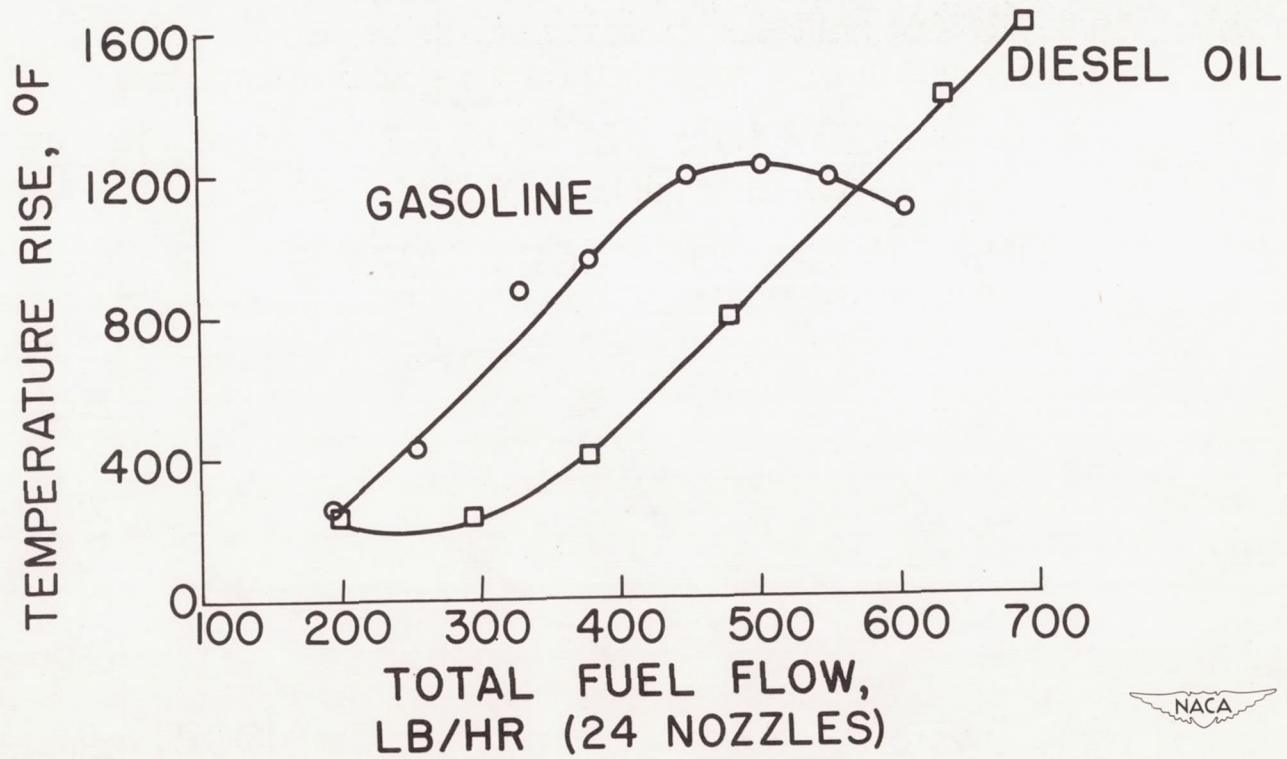
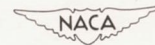

Figure 27. - Temperature rise for two fuels.  
 Annular combustor; inlet pressure, 9.2  
 pounds per square inch; inlet temperature,  
 150° F; inlet velocity, 200 feet per second.



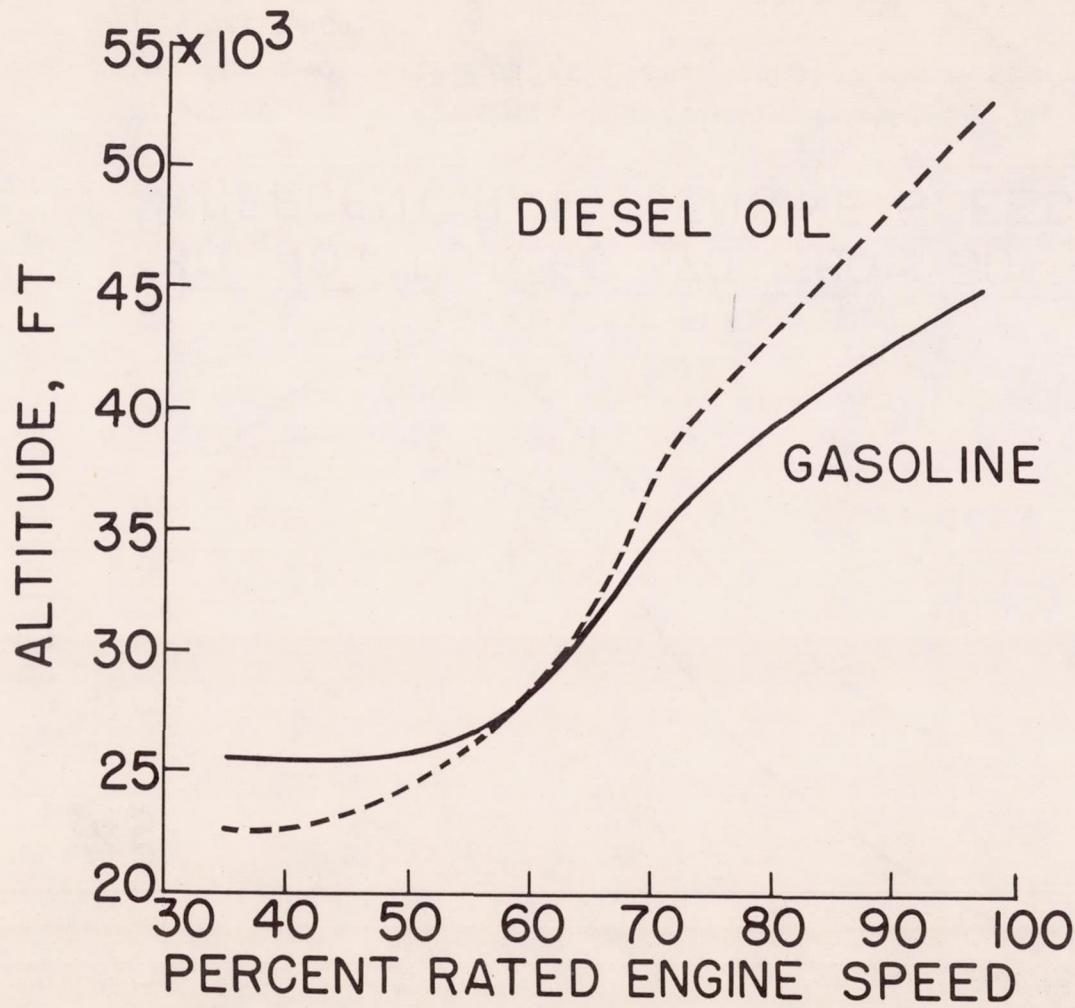
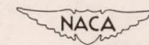

Figure 28. - Altitude operational limits for two fuels. Annular combustor; Mach number, 0.



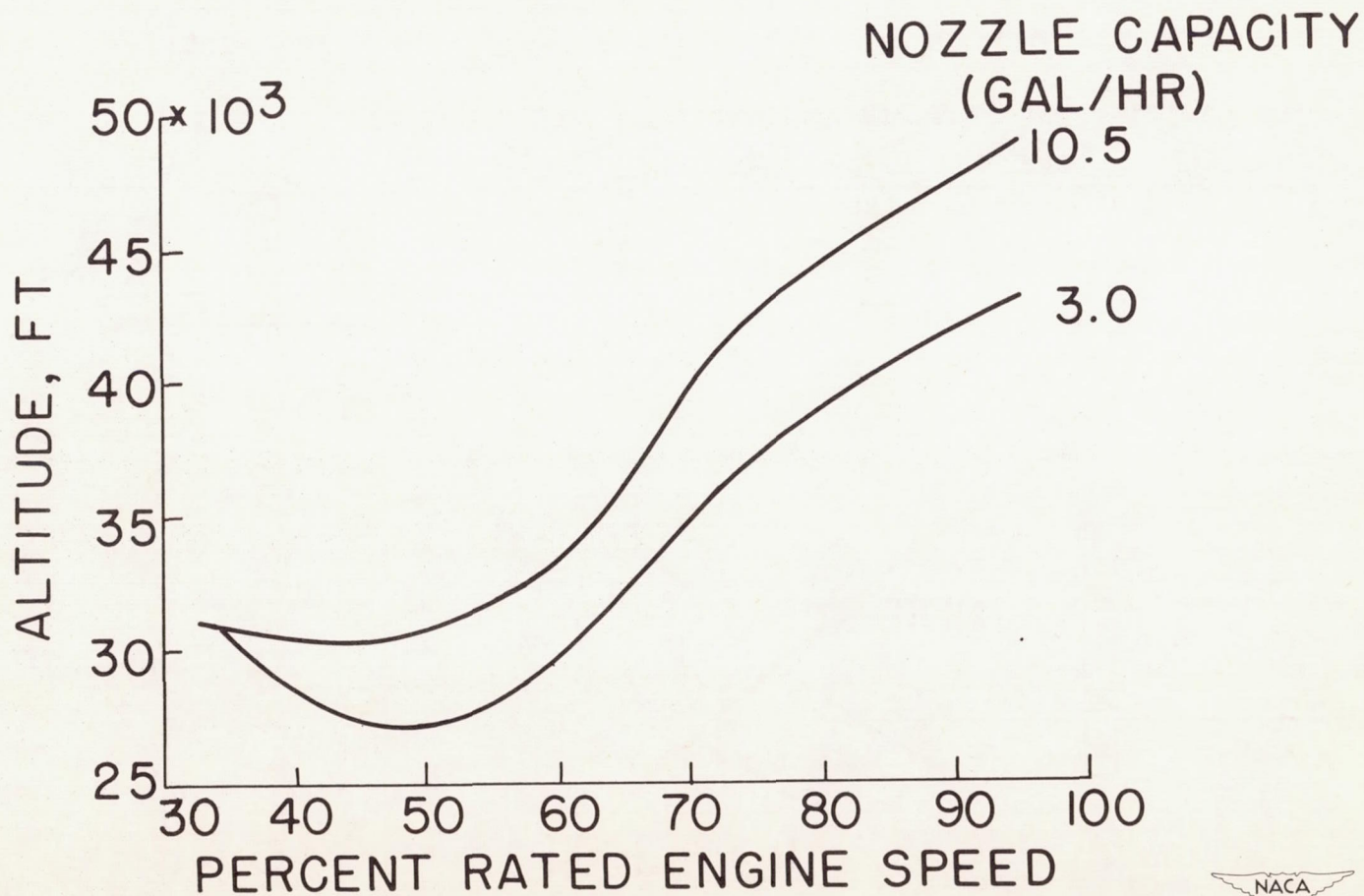
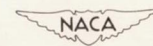

Figure 29. - Altitude operational limits of gasoline for two nozzle capacities. Annular combustor; Mach number, 0.



1421

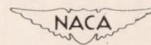
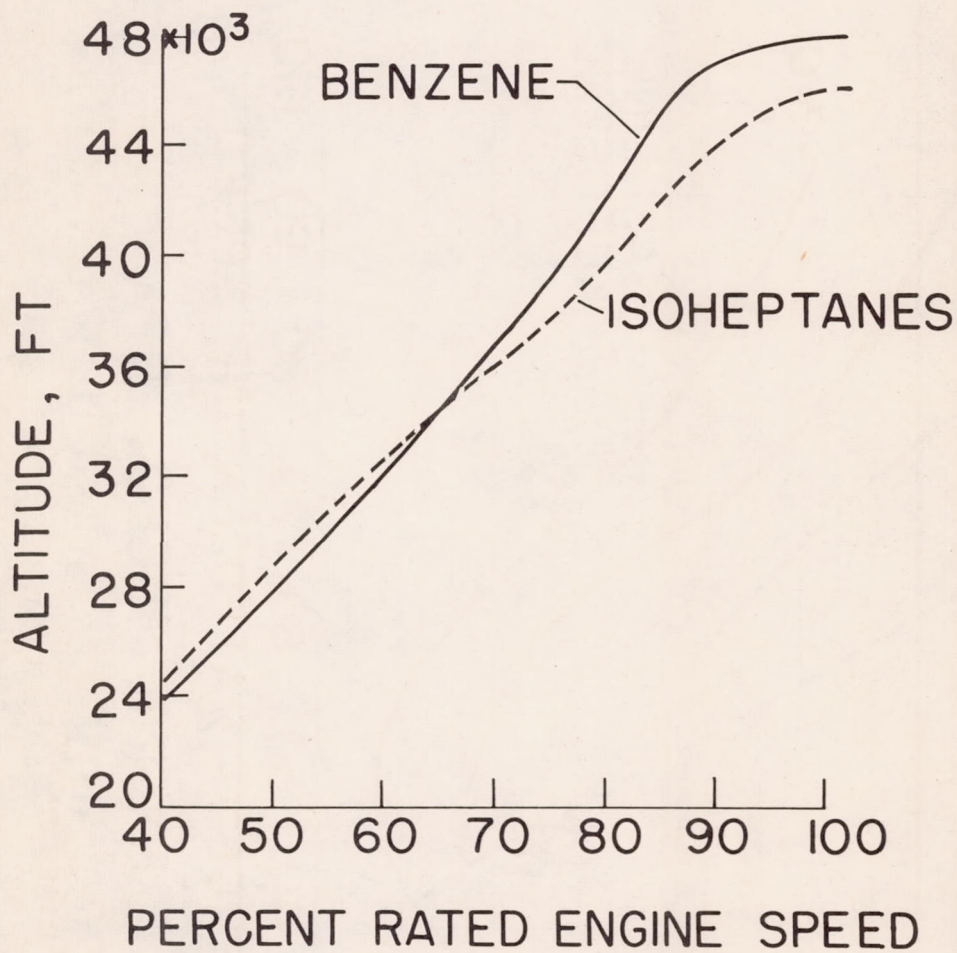

Figure 30. - Altitude operational limits for fuels of varying composition. Annular combustor; Mach number, 0.

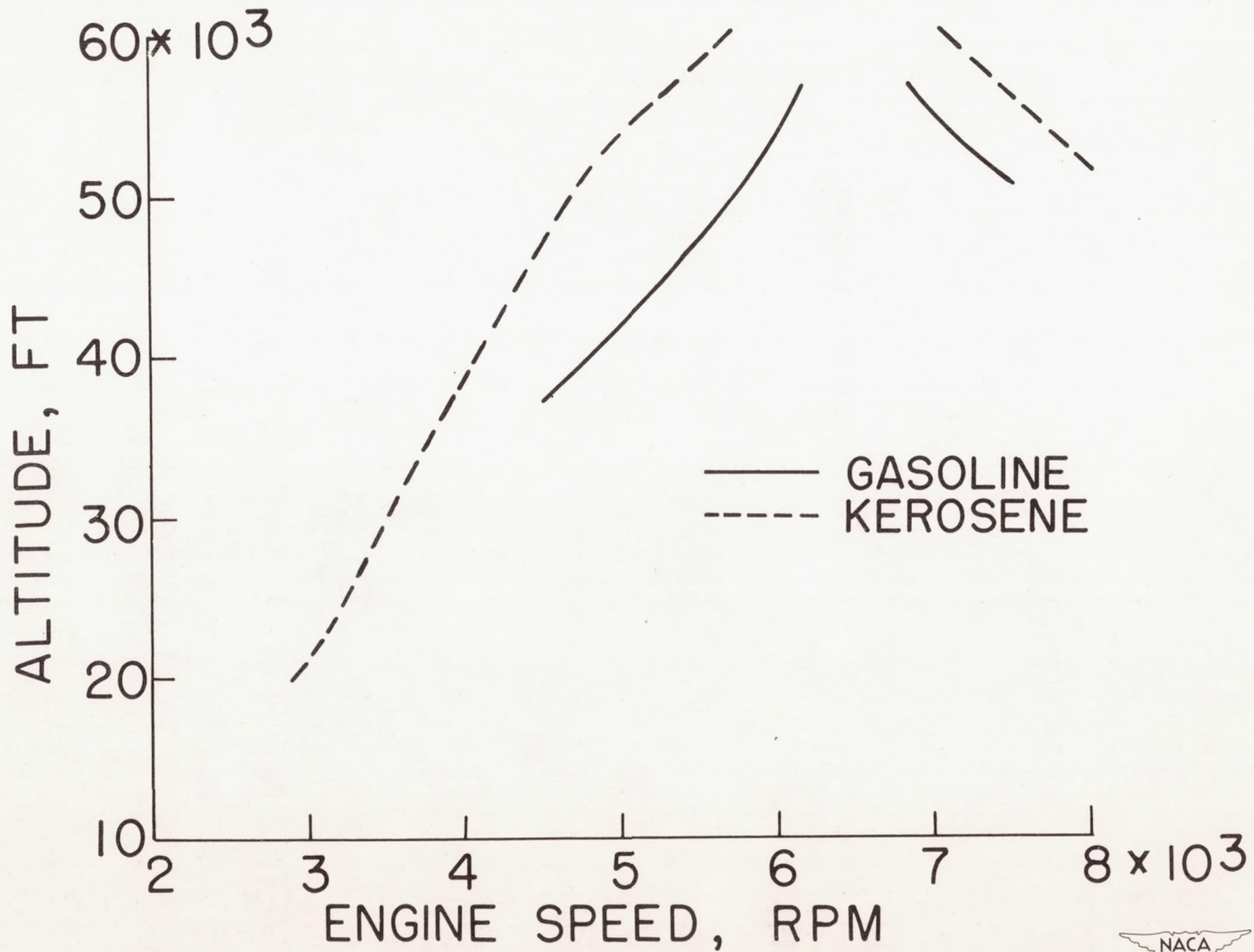
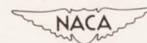

Figure 31. - Altitude operational limits for two fuels in a tubular combustor.



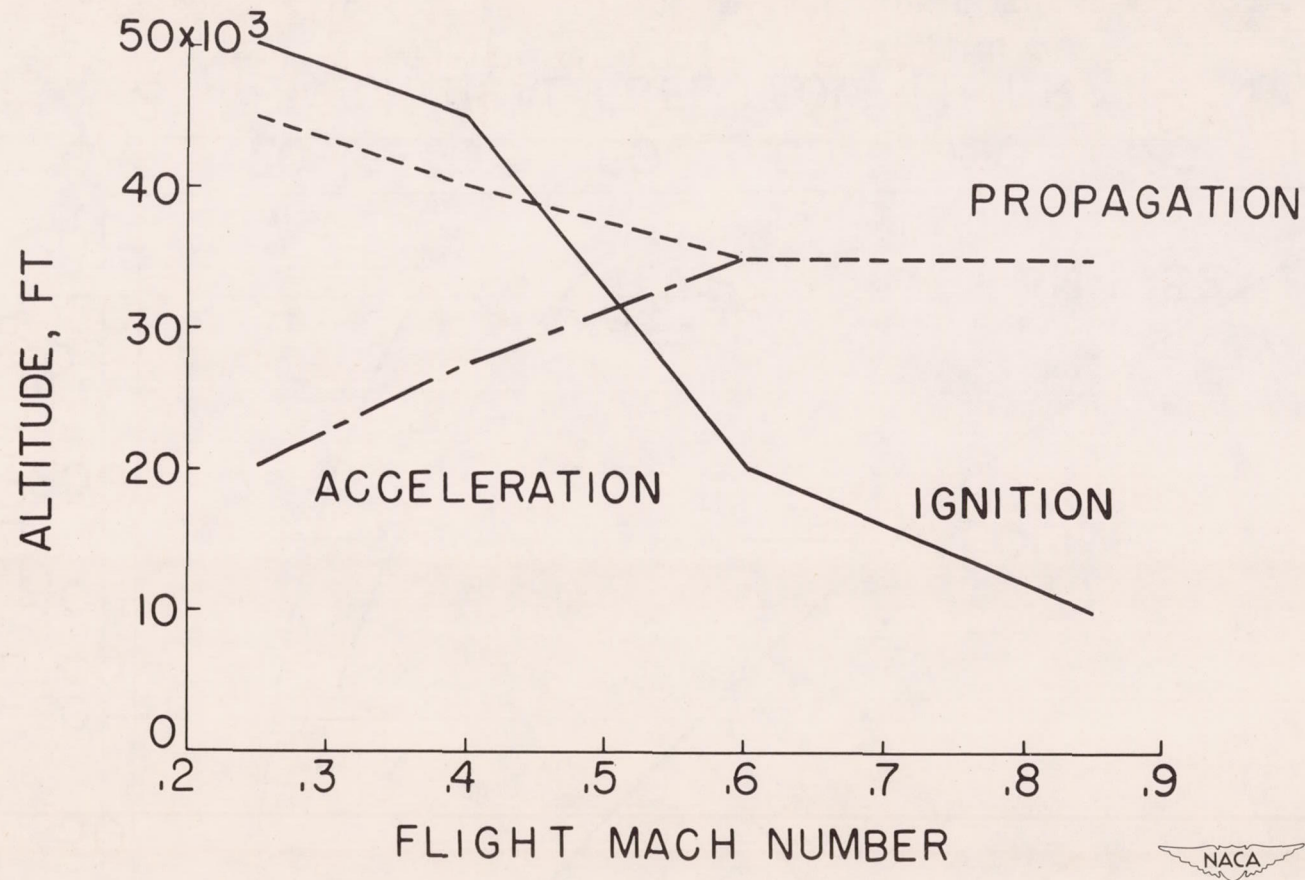
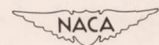

Figure 32. - Altitude ignition, flame propagation, and acceleration limits.



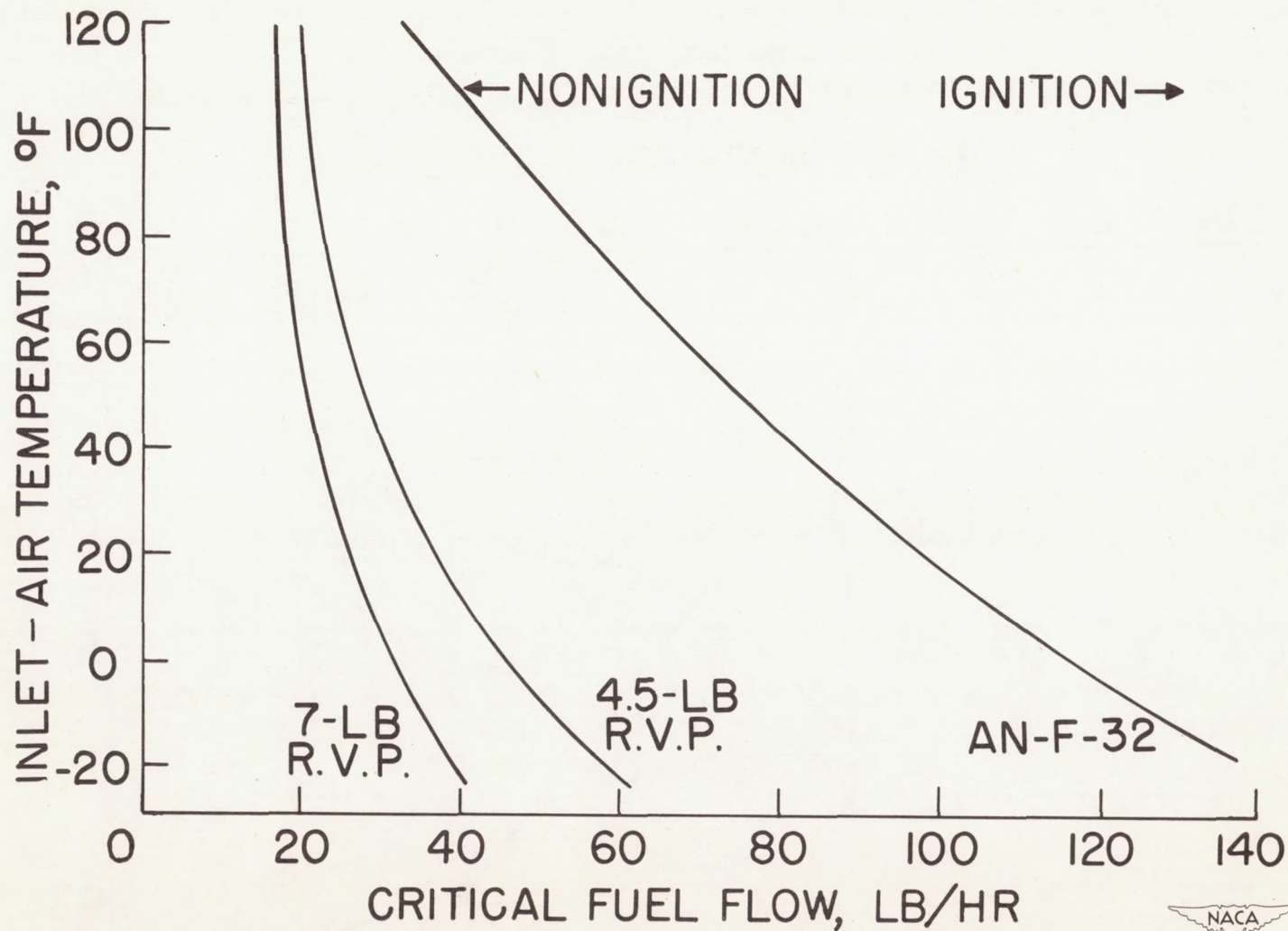

Figure 33. - Effect of temperature on fuel flow required for ignition in combustor. Engine speed, 1600 rpm; Mach number, 0; sea level.



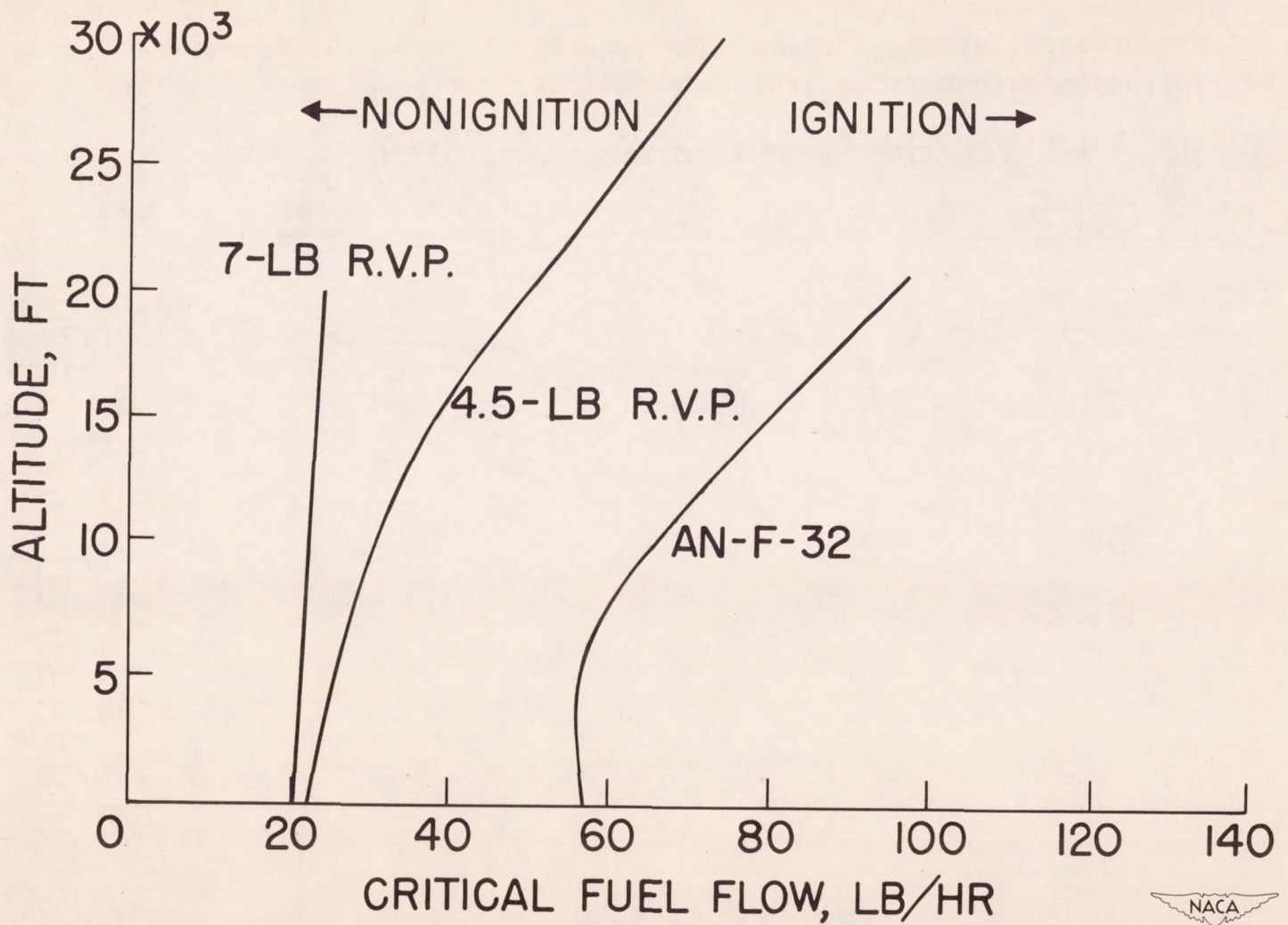
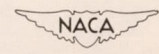

Figure 34. - Effect of altitude on fuel flow required for ignition. Engine speed, 1600 rpm; Mach number, 0.



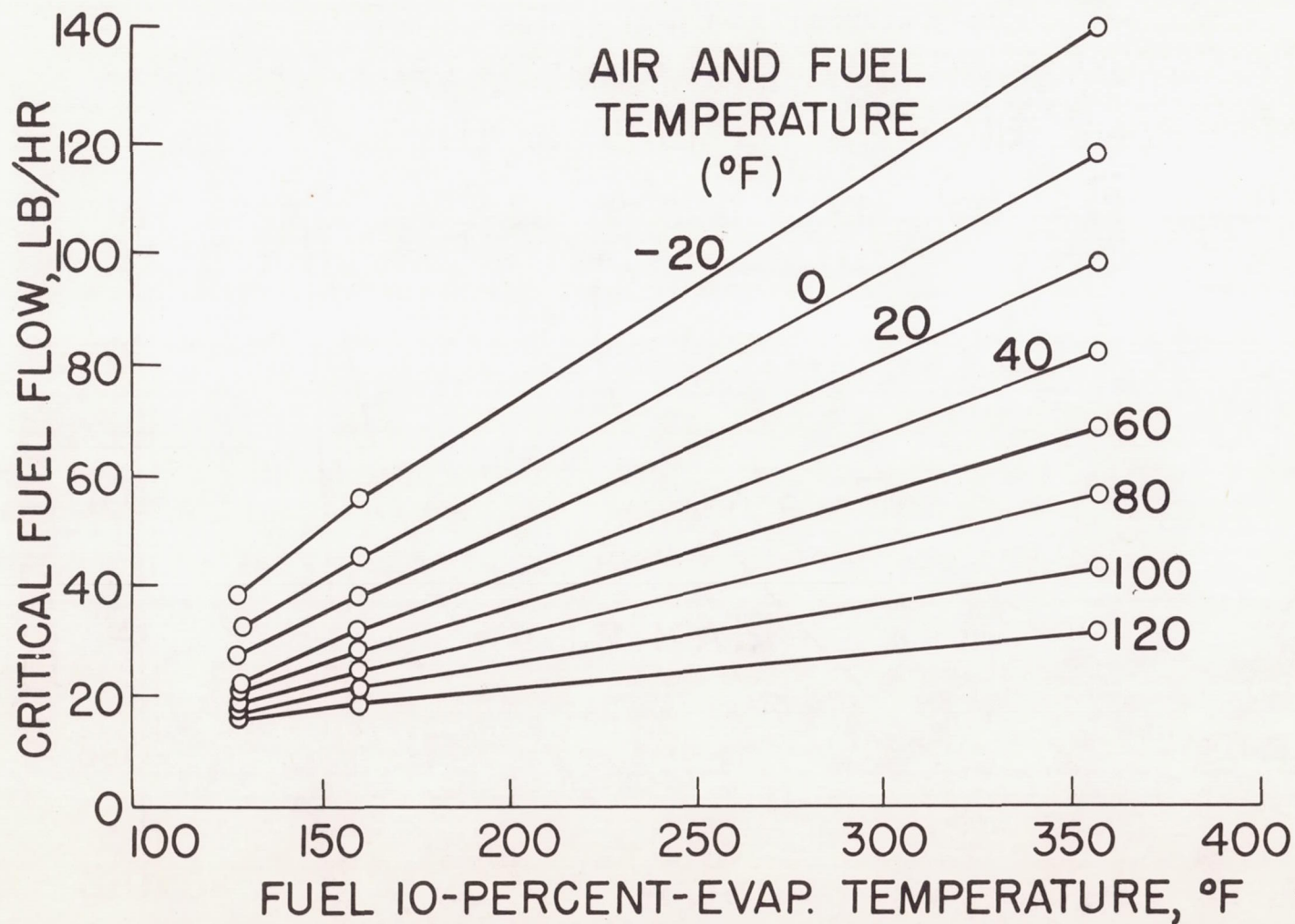

Figure 35. - Fuel flow required for ignition in single combustor.  
 Engine speed, 1600 rpm; Mach number, 0; sea level.



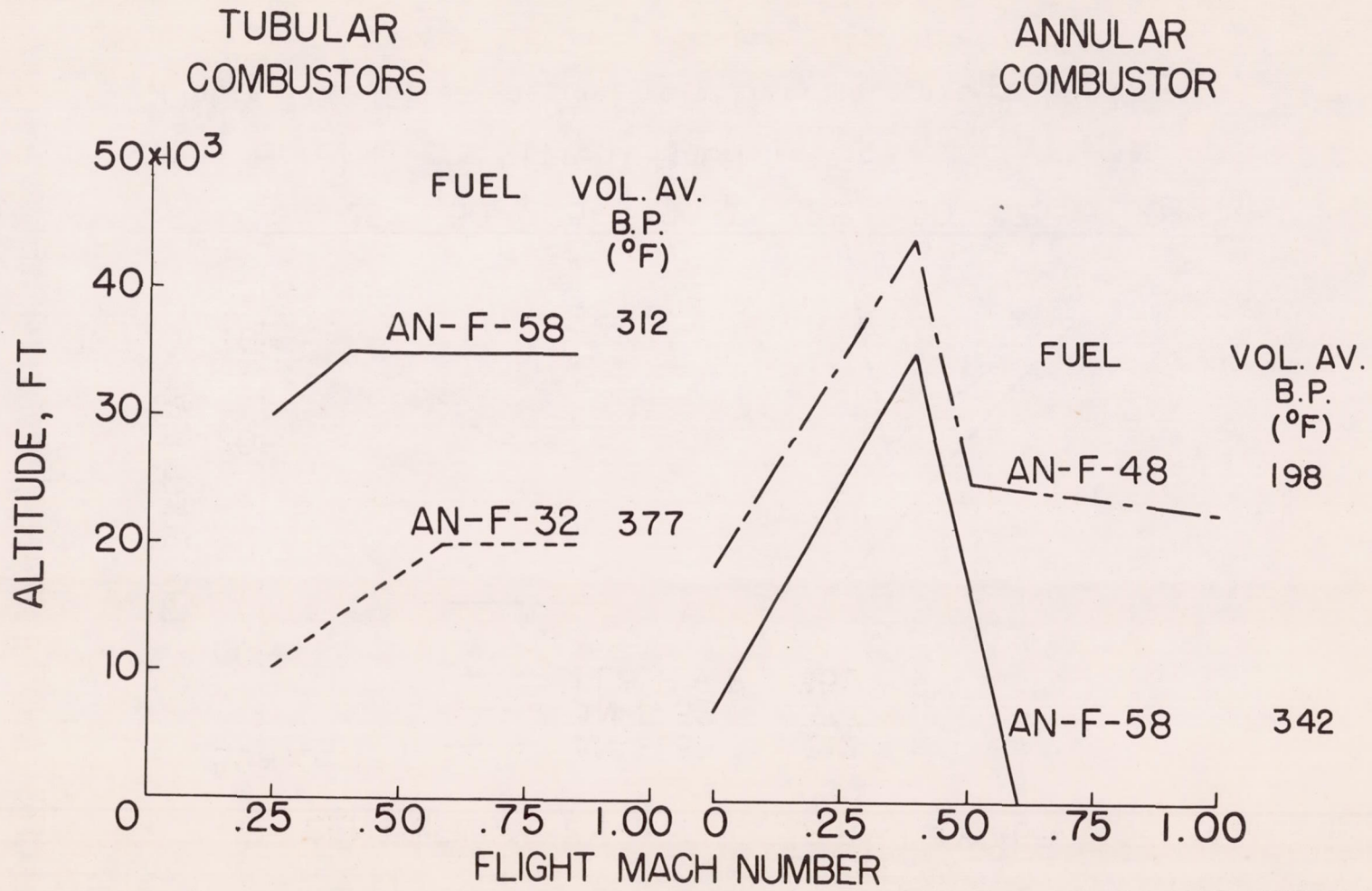
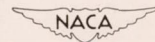

Figure 36. - Effect of fuel volatility on starting limits.



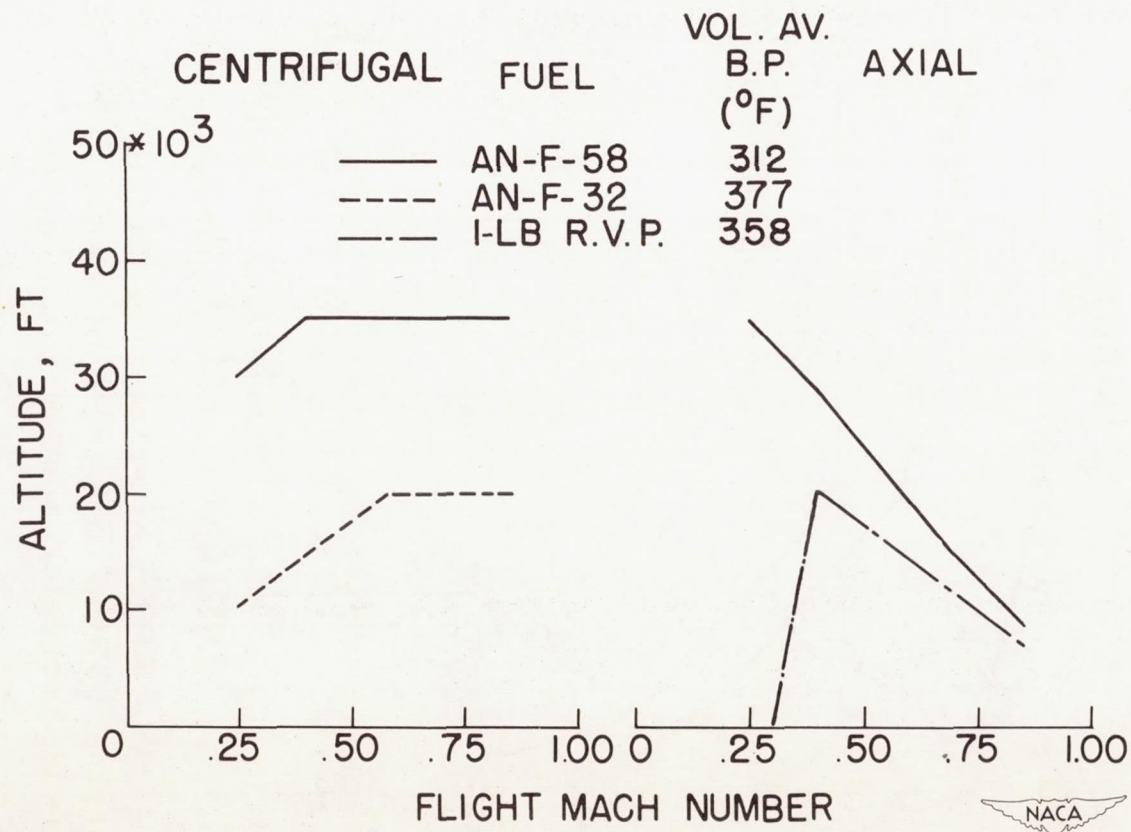

Figure 37. - Effect of fuel volatility on ignition limits.

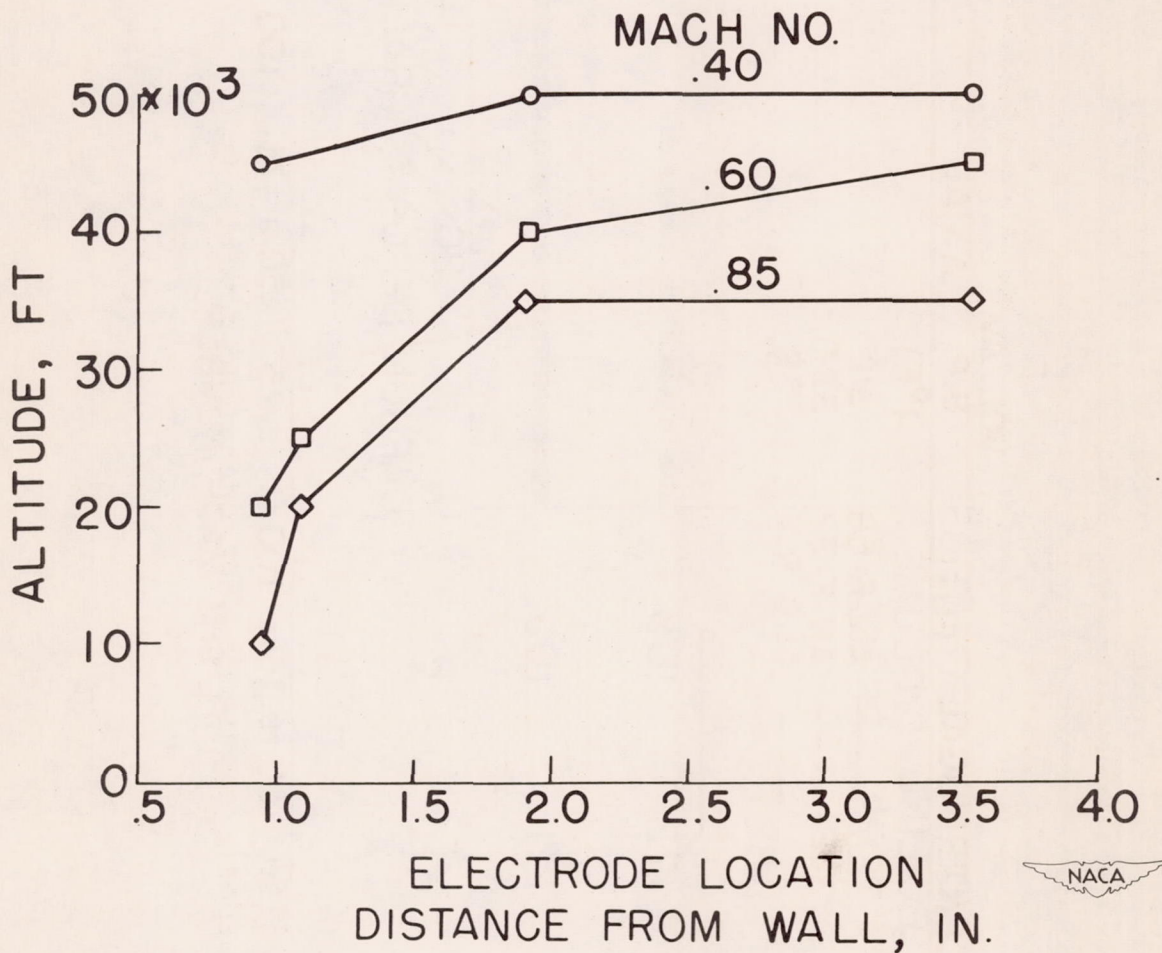
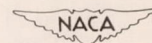

Figure 38. - Effect of spark-plug location on altitude starting. Rated cone angle of spray,  $120^\circ$ ; fuel, AN-F-58; combustor diameter, 7.1 inches.



1421

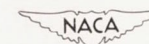
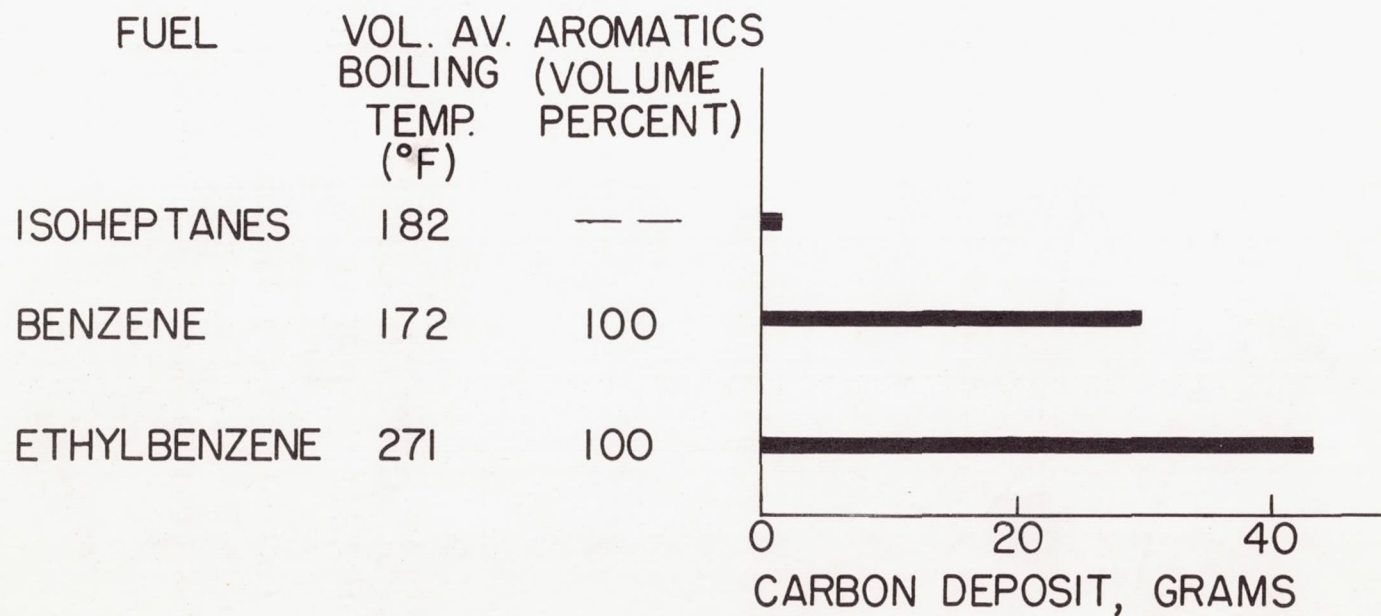

Figure 39. - Effect of fuel volatility and molecular structure on carbon deposition at constant operating conditions.

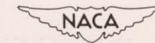
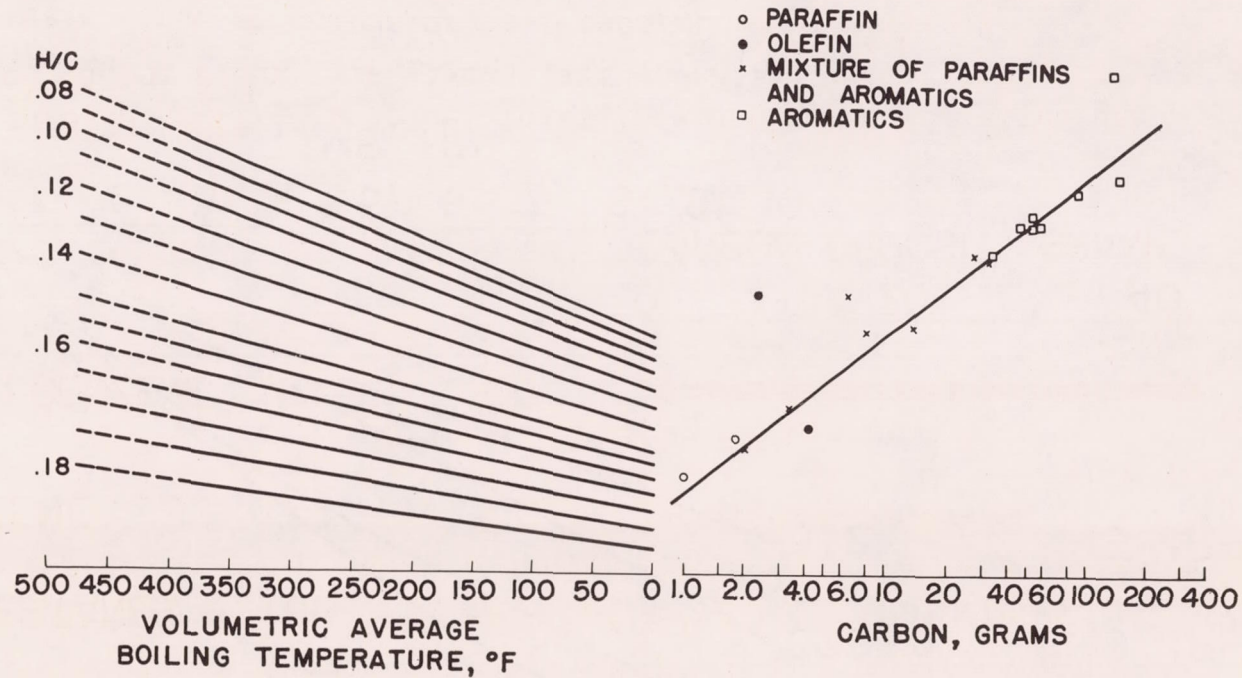

Figure 40. - Correlation of carbon deposits with fuel properties. Annular combustor; running time, 2 hours; 50-percent rated engine speed; sea level.

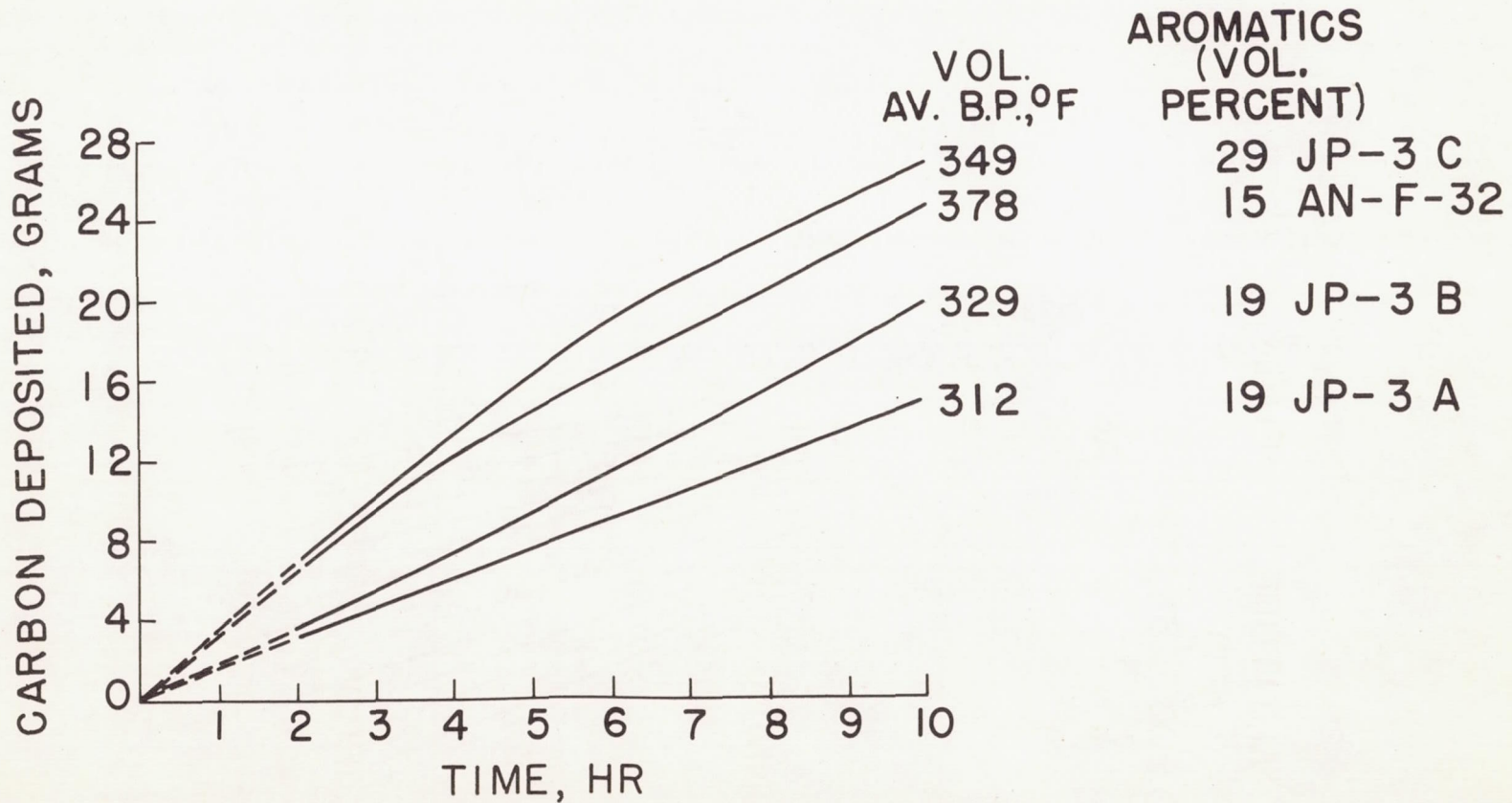
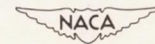

Figure 41. - Carbon deposition with turbojet fuels. Tubular combustor; altitude, 20,000 feet; 90-percent rated engine speed.





1421

ALTITUDE (FT)		FUEL
20,000	35,000	
○	◌	AN-F-32
□	◻	JP-3 A
◇	◊	JP-3 B
△	◡	JP-3 C

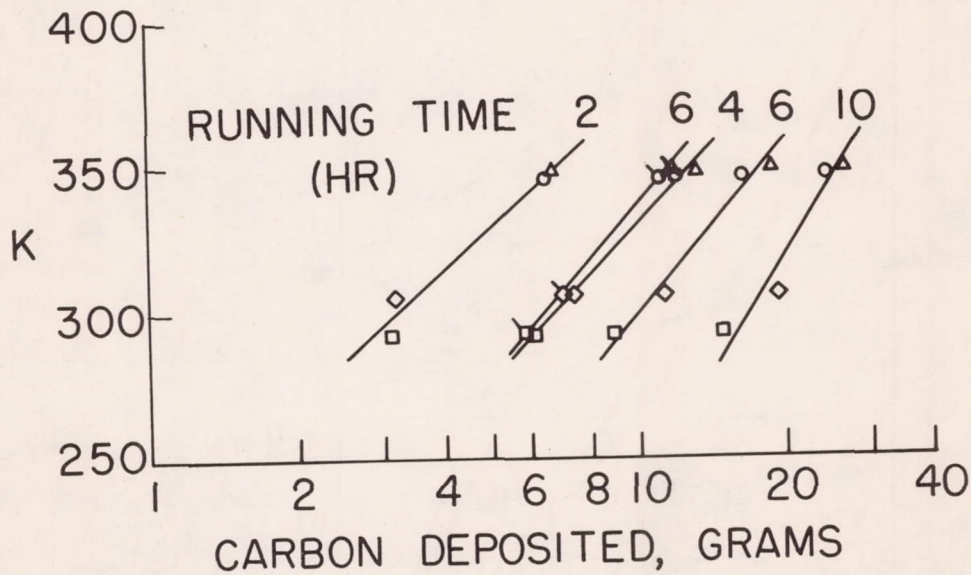

Figure 42. - Carbon deposition of four fuels. Tubular combustor; 90-percent rated engine speed.

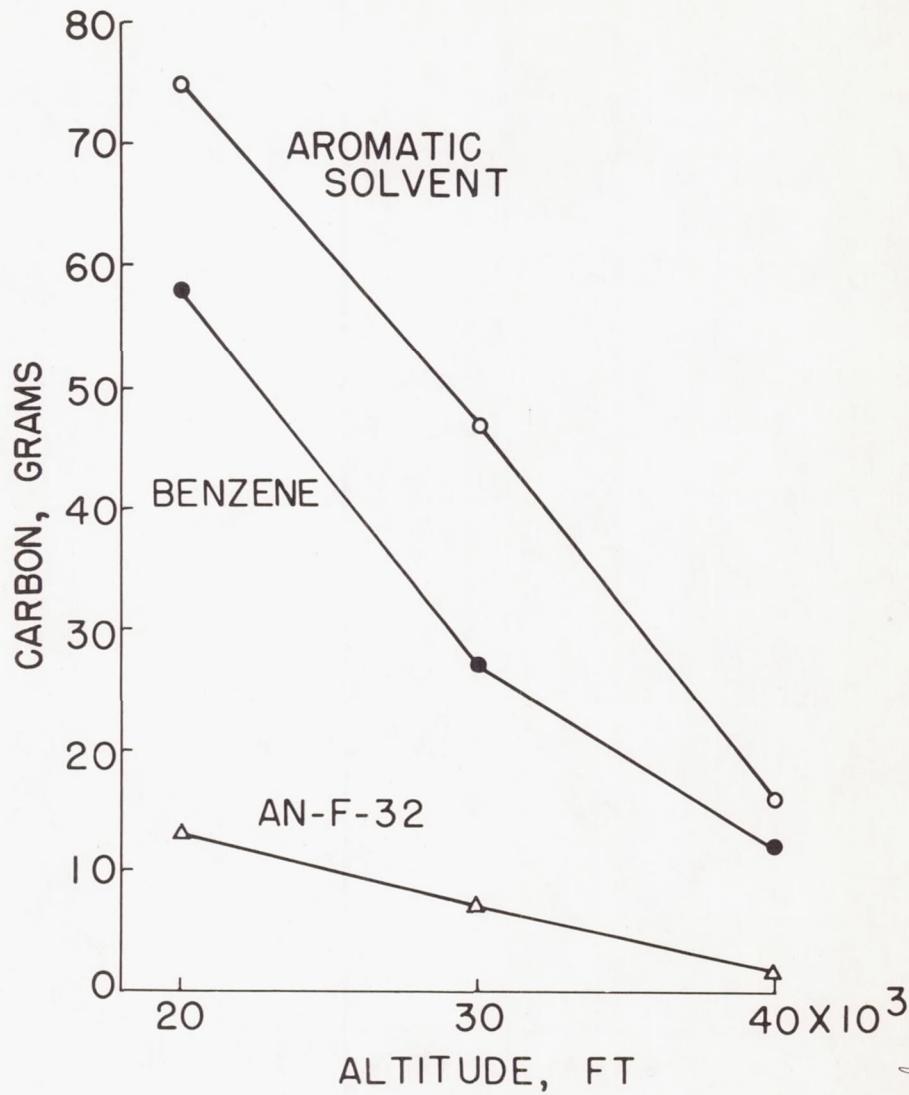

Figure 43. - Effect of altitude on carbon deposits. Annular combustor; rated engine speed; time,  $1\frac{1}{4}$  hours.



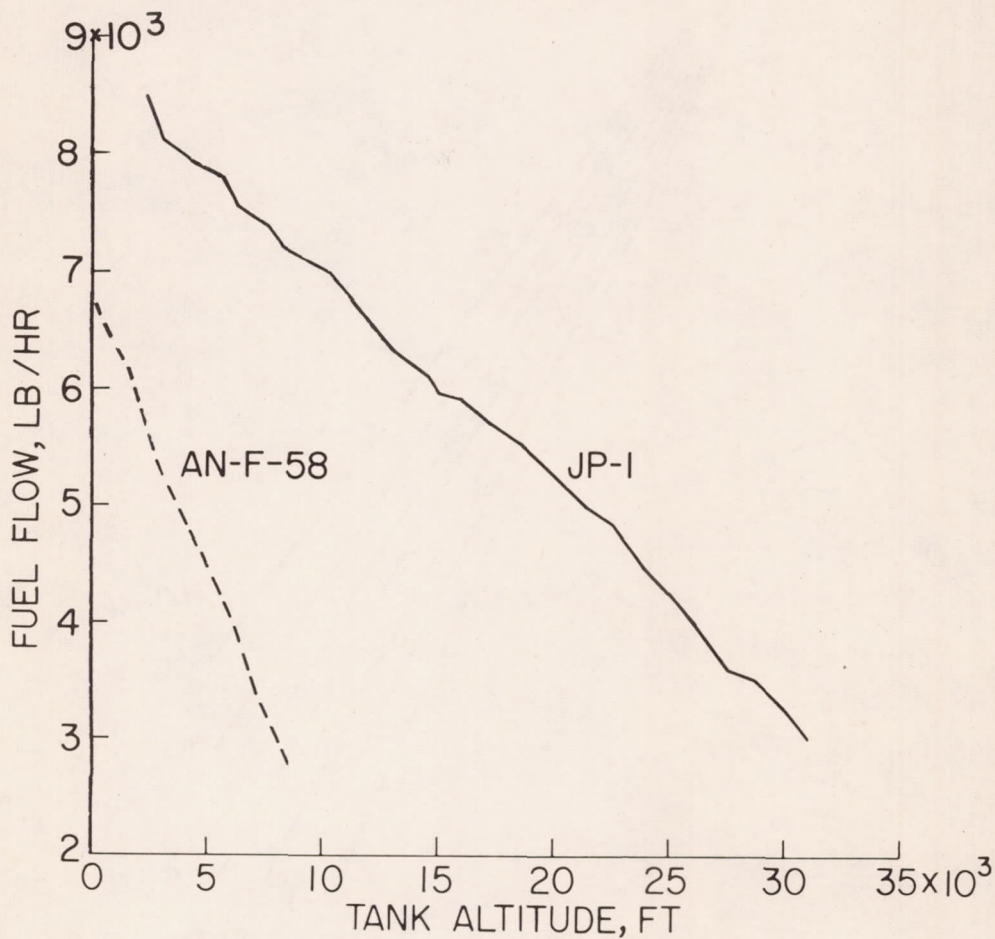
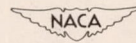

Figure 44. - Pump deliveries with fuels of different volatility. Initial fuel temperature, 110° F; rate of climb, 5000 feet per minute; pump speed, 3400 rpm.



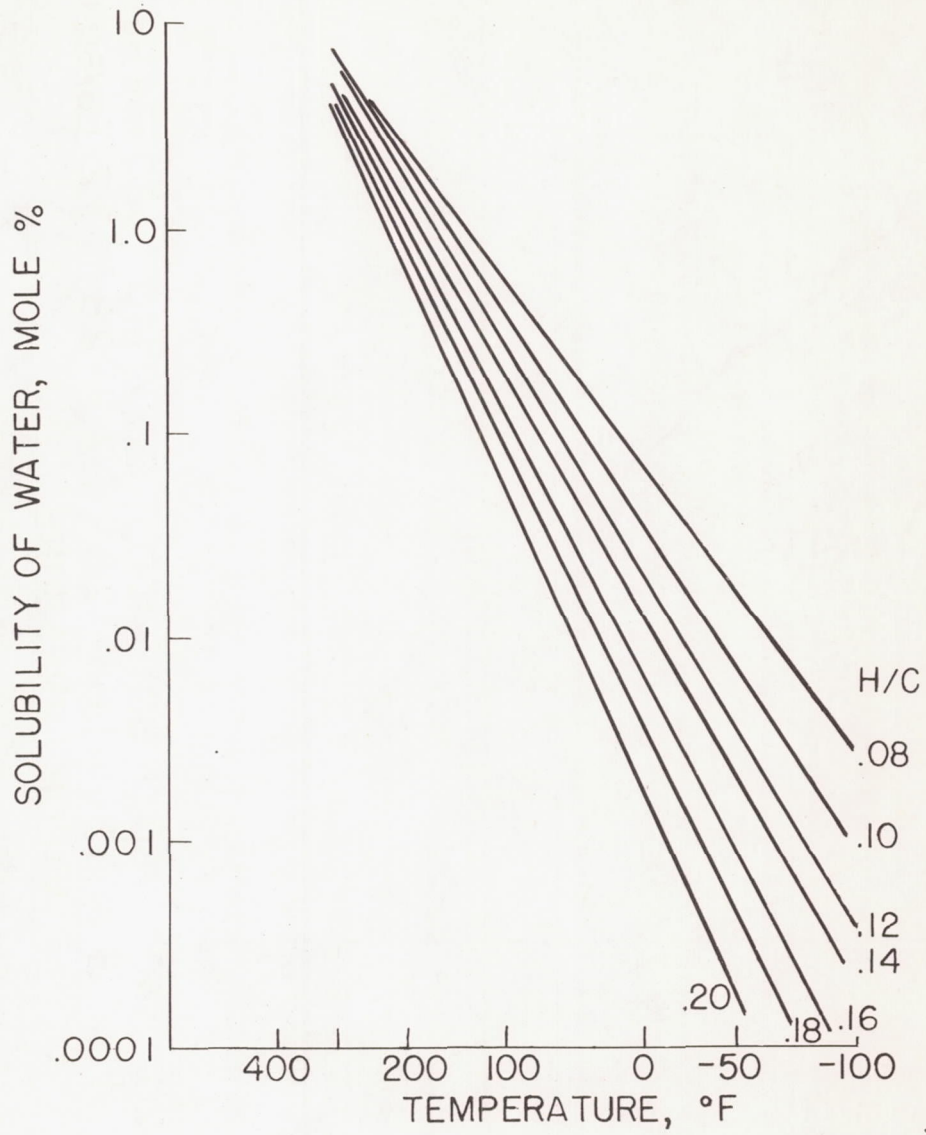

Figure 45. - Solubility of water in hydrocarbons.

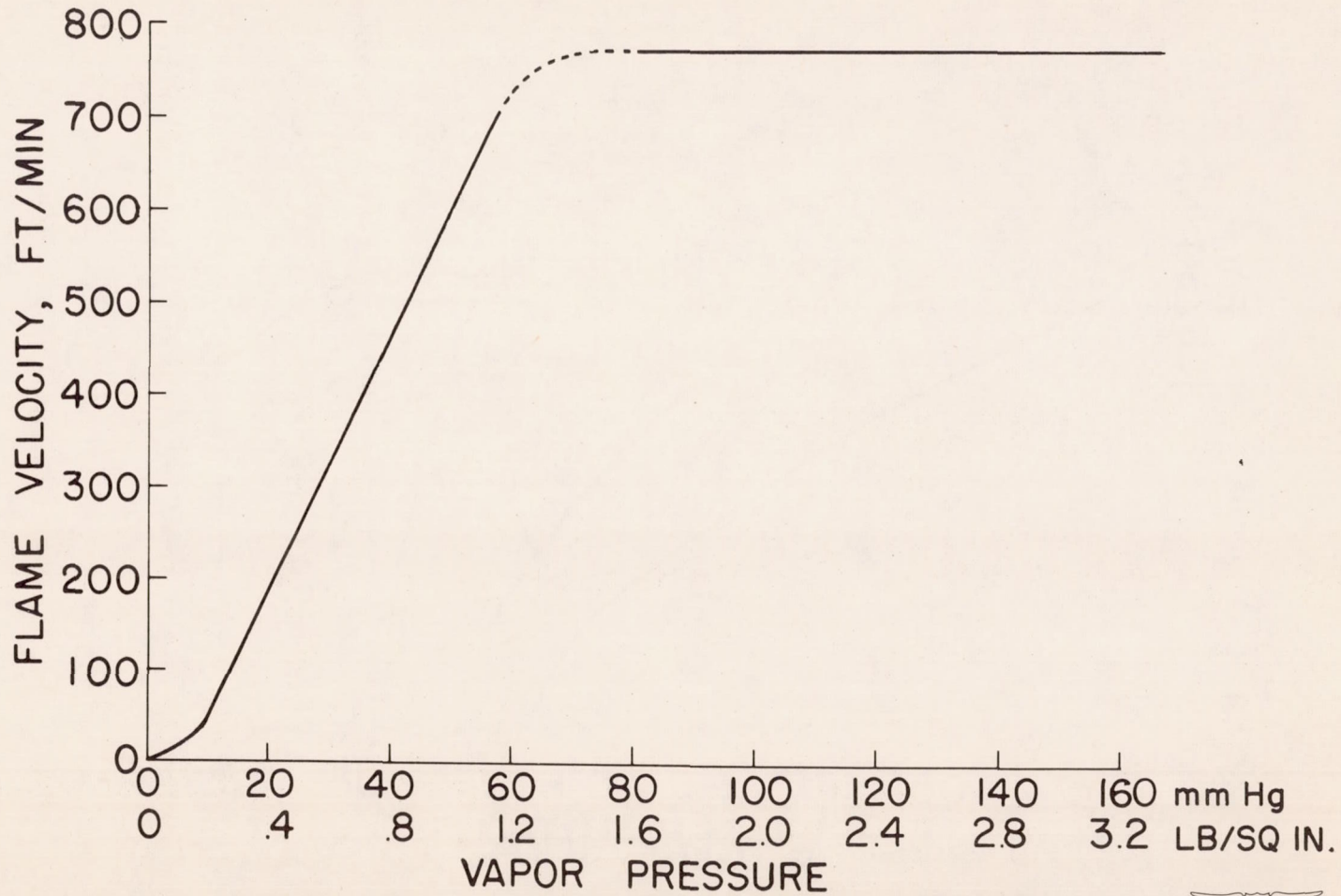
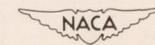

Figure 46. - Effect of vapor pressure on flame velocity in open tray.



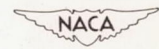
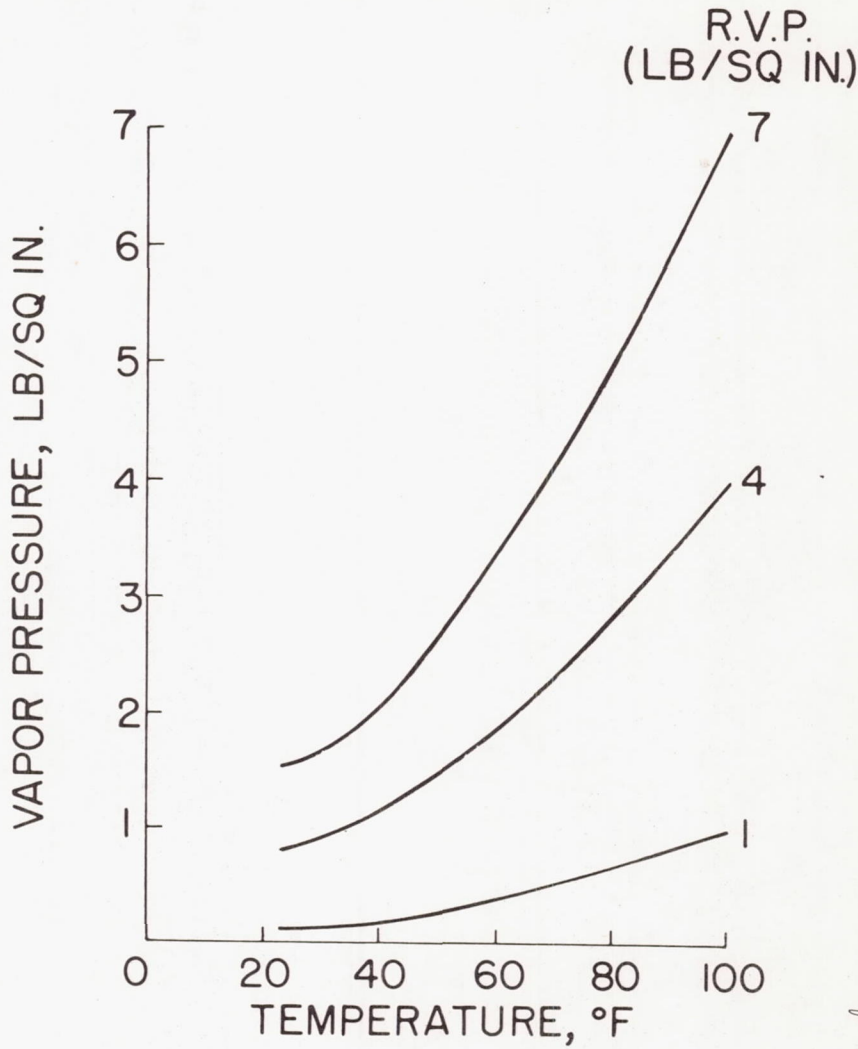

Figure 47. - Effect of temperature on vapor pressure of fuels.

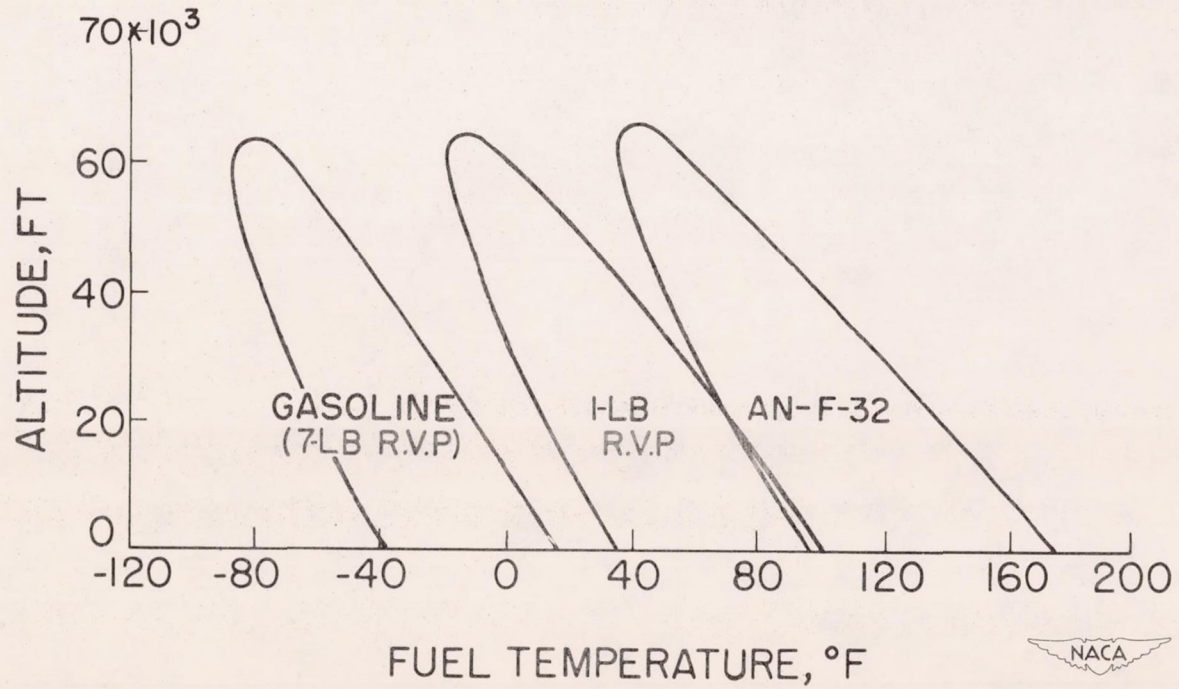

Figure 48. - Explosive limits of fuels.

