

RESEARCH MEMORANDUM

INVESTIGATION OF LIQUID FLUORINE - LIQUID AMMONIA
PROPELLANT COMBINATION IN A 100-POUND-THRUST
ROCKET ENGINE

By Edward A. Rothenberg and Howard W. Douglass

Lewis Flight Propulsion Laboratory
Cleveland, Ohio

**NATIONAL ADVISORY COMMITTEE
FOR AERONAUTICS**

WASHINGTON

July 3, 1953

Declassified May 16, 1958

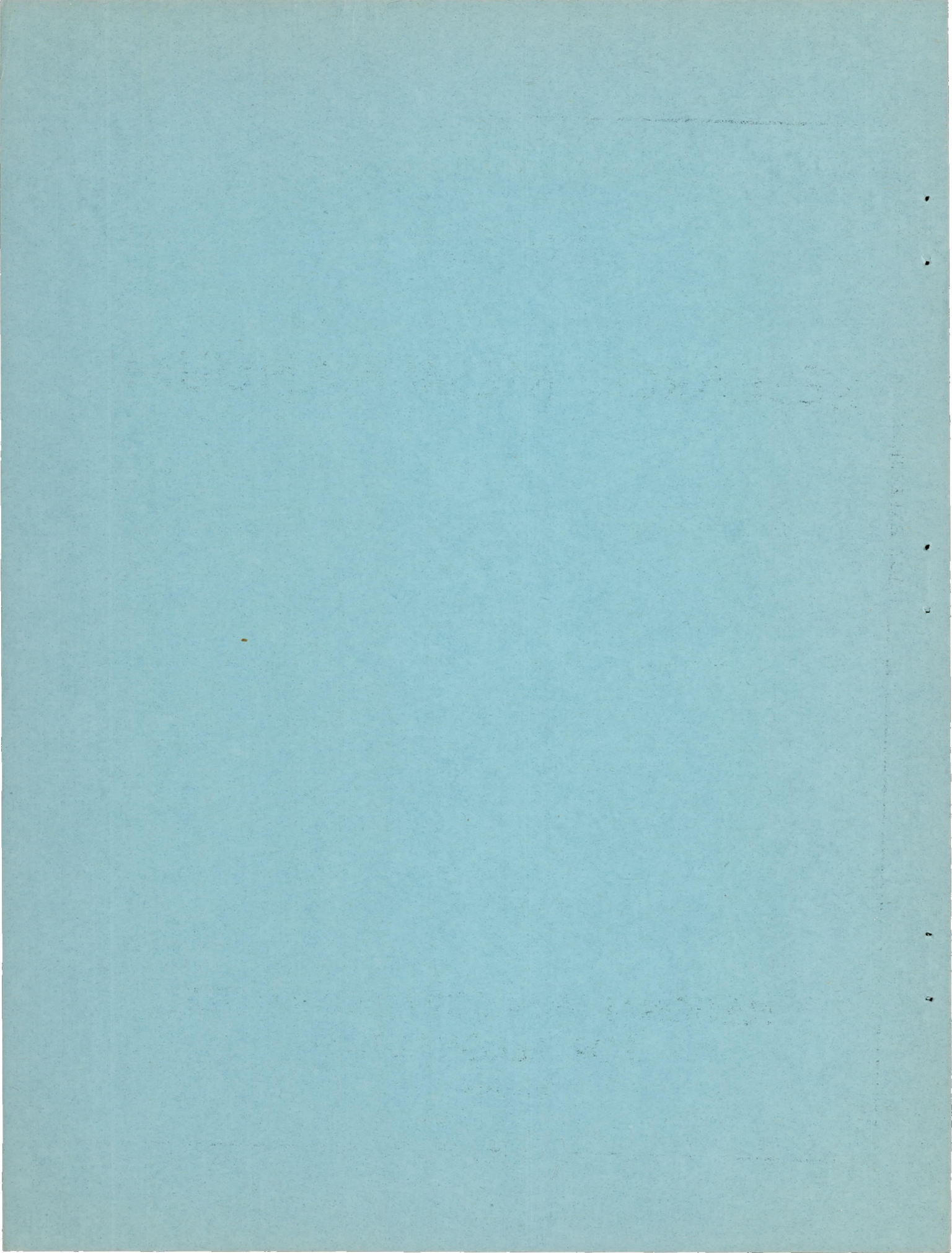

NATIONAL ADVISORY COMMITTEE FOR AERONAUTICS

RESEARCH MEMORANDUM

INVESTIGATION OF LIQUID FLUORINE - LIQUID AMMONIA PROPELLANT

COMBINATION IN A 100-POUND-THRUST ROCKET ENGINE

By Edward A. Rothenberg and Howard W. Douglass

SUMMARY

CY-1

The performance of the liquid fluorine - liquid ammonia propellant combination was investigated in 100-pound-thrust, water-cooled engines operating at a chamber pressure of 300 pounds per square inch absolute. Several impinging-jet injectors were evaluated in chambers of characteristic length equal to 50 inches. A showerhead-type injector was run in a chamber of characteristic length equal to 100 inches.

Performance data are presented in curves of specific impulse, characteristic velocity, thrust coefficient, and total heat rejection against weight percent fuel.

The highest performance values were obtained with a two-oxidant-on-one-fuel impinging-jet injector with four sets of holes. A maximum experimental specific impulse of 270 pound-seconds per pound was obtained at 29 percent fuel. This value corresponds to 87 percent of the maximum theoretical specific impulse based on equilibrium composition expansion. The maximum characteristic velocity obtained with this 4(2-1) injector was 6600 feet per second at 32 percent fuel, or 93 percent of the theoretically obtainable velocity. Average total heat rejection varied between 2.5 and 3.1 Btu/(sec)(sq in.) over the range of 20 to 40 percent fuel.

Lower performance values were obtained in runs made with a one-oxidant-on-one-fuel impinging-jet injector fitted with a turbulence coil and with a showerhead-type injector, while burn-outs resulted in runs made with a second two-oxidant-on-one-fuel impinging jet (with six sets of holes) and one of a conical array of fuel jets impinging inside a similar cone of oxidant jets.

The maximum thrust coefficient for the combustion-chamber nozzles used was 1.31, 92 percent of the theoretical maximum value based on equilibrium composition expansion.

It was noted that runs started with an oxidant lead resulted in either rough starts or explosions, while runs begun with a fuel lead were generally smooth-starting.

INTRODUCTION

Present range requirements for rocket missiles leave the designer with some choice of propellant combinations; but, as these requirements become more demanding, missile weight considerations will focus attention on high-performance oxidants such as fluorine. Liquid fluorine offers the designer of long-range rocket missiles the advantages of high performance, high density, and spontaneous ignition - all tending to minimize total missile weight.

Fluorine is at present rather costly. Adequate techniques have been developed for the handling and transportation of only relatively small quantities. However, the raw materials which go into the manufacture of fluorine are abundant, and, as new and large-scale uses are found for it, the increased demand can be expected to result in an appreciable decrease in price. Further, experience will help to develop safe and simple procedures for handling and shipping the gas or liquid in large quantities.

Before missile designers can seriously consider fluorine as a rocket oxidant, it must be shown that near-theoretical performance can be achieved experimentally. Work already completed at the NACA Lewis laboratory with diborane and a mixture of ammonia and hydrazine as fuels with liquid fluorine (refs. 1 and 2, respectively) has shown that experimental specific impulse values of the order of 88 percent and characteristic velocity values of approximately 95 percent of the theoretical maximums, based on equilibrium composition expansion, are obtainable in 100-pound-thrust engines. However, preliminary work in a 50-pound-thrust engine with the ammonia-fluorine combination performed at the Jet Propulsion Laboratory of the California Institute of Technology (ref. 3) indicated a maximum of 84 percent of the theoretical characteristic velocity. Experimental performance evaluated at Ohio State University in low-thrust engines at various chamber pressures (ref. 4) was 70 percent of the theoretical maximum specific impulse. In view of the experimental results in reference 2, it was concluded that, in spite of the high reactivity of fluorine, the injection method is still of primary importance in achieving high combustion efficiencies.

It was, therefore, the intention of the present work at the NACA Lewis laboratory to further reveal the nature of the problem of efficiently burning liquid fluorine and liquid ammonia in a rocket engine. Accordingly, the performance efficiencies of several different injector configurations were evaluated over a propellant mixture range with this combination in 100-pound-thrust, water-cooled rocket engines operating at a chamber pressure of 300 pounds per square inch absolute.

Specific impulse, characteristic velocity, thrust coefficient, and total heat rejection were calculated from measured thrust, propellant flows, chamber pressure, coolant flow, and coolant temperatures. Curves of the performance parameters plotted against weight percent fuel are presented.

Impinging-jet injectors, run in chambers of characteristic length equal to 50 inches, included two different two-oxidant-on-one-fuel injectors (one with four sets of holes, the other with six sets), a one-oxidant-on-one-fuel injector with two different turbulence coils, and one of a conical array of fuel jets impinging inside a similar cone of oxidant jets. A showerhead-type injector also was run in a chamber of characteristic length equal to 100 inches.

NOMENCLATURE

The following symbols are used in this report:

C_F	thrust coefficient, thrust/(chamber pressure)(throat area)
C^*	characteristic velocity, ft/sec, (chamber pressure)(throat area)/propellant flow
g	gravitational constant, 32.2 ft/sec ²
I	specific impulse, lb-sec/lb, thrust/propellant flow
I_{ex}	experimental specific impulse, lb-sec/lb
I_h	experimental specific impulse corrected for heat rejection, lb-sec/lb
$I_{h,p}$	experimental specific impulse corrected for heat rejection and chamber-pressure variation, lb-sec/lb
I_p	experimental specific impulse corrected for chamber-pressure variation, lb-sec/lb

J	mechanical equivalent of heat, 778 ft-lb/Btu
K	slope of I against log P_c curve, 88.65 for ammonia-fluorine combination
L^*	characteristic engine length, in., chamber volume/throat area
P_c	experimental chamber pressure, lb/sq in. abs
Q	total heat transfer, Btu/sec
T_c	combustion temperature, $^{\circ}K$
T_e	temperature of rocket exhaust at nozzle exit, $^{\circ}K$
η	ideal thermodynamic cycle efficiency, $(1 - T_e/T_c)$

EQUIPMENT AND INSTRUMENTATION

Propellants

Anhydrous liquid ammonia was obtained in commercial cylinders and loaded directly into the fuel supply tank before each run. Gaseous fluorine of at least 98 percent purity was purchased in chrome-molybdenum steel cylinders, each containing 6 pounds of the gas under a pressure of approximately 360 pounds per square inch. The fluorine gas was condensed directly into the liquid-nitrogen-cooled oxidant supply tank immediately before each run.

Facilities

A flow diagram of the apparatus used throughout the investigation is shown in figure 1. The facilities described herein were similar to those of reference 2.

Initially, the gaseous-fluorine supply system permitted use of only one cylinder at a time. Subsequently, six gaseous-fluorine cylinders were manifolded inside a protective steel barrier as illustrated in figure 2. The first of these cylinders was fitted with a gearbox and an extension handle for remote operation. Extension rods passing through the top of the barrier were fitted directly to the valve stems on the other five cylinders. These cylinders were opened with a long-handled wrench from outside the barrier. A photograph of this system is shown in figure 3(a).

The fluorine flow system was made entirely of brass, nickel, and monel tubing and fittings. The fluorine supply tank was suspended from a cantilever weigh-beam and immersed in a liquid-nitrogen bath (fig. 3(b)).

Stainless steel was used throughout the fuel flow system. The fuel supply tank was suspended from a cantilever weigh-beam and was immersed in a water bath to provide a buoyant force to nearly counter-balance the weight of the tank. A photograph of the fuel supply system is shown in figure 3(c).

Pressurized, dry helium was used to force the propellants from the supply tanks to the rocket engine.

The thrust stand with propellant lines, valving, and mounted rocket engine is shown in figure 3(d). It is a bearing-type pivoted stand with the engine mounted at a downward angle of 30° .

The rocket engines were designed to deliver 100 pounds thrust at a chamber pressure of 300 pounds per square inch absolute. Combustion chambers and nozzles were constructed with two types of coolant passage, the annular (fig. 4(a)) and the spiral type (fig. 4(b)). The chambers had characteristic lengths of either 50 or 100 inches.

The performance and operational characteristics of several types of impinging-jet injector were studied. Figure 5(a) is a photograph and cross-sectional sketch of the first of these, a triplet-type two-oxidant-on-one-fuel injector with four sets of holes, hereafter designated 4(2-1). A helium bleed around the fuel orifices was incorporated in this injector for studies with another propellant combination; however, the gas bleed was not used for the ammonia-fluorine investigation. A one-oxidant-on-one-fuel injector with eight sets of holes, designated 8(1-1)CA, is shown in figure 5(b). It was fitted with a water-cooled copper turbulence coil. The coil was later moved closer to the injector face, within $1/8$ inch of the impingement point, and the coil diameter was decreased to provide for the impingement of the resultant streams on the coil over a wider range of fuel percentages. This modified configuration is referred to as the 8(1-1)CB injector. The showerhead-type injector used (fig. 5(c)) had 22 fuel and 66 oxidant holes. A second type of triplet injector (6(2-1)) used is shown in figure 5(d). It had six sets of holes and a somewhat shorter impingement length than the 4(2-1). Figure 5(e) shows the double-cone injector consisting of a conical array of eight oxidant jets commonly impinging on the resultant stream from a similar cone of eight fuel jets.

Some of the more important dimensions of the six injectors used are presented in table I.

Instrumentation

The instrumentation used throughout this investigation was the same as that described in reference 2.

Thrust and propellant flow rates were measured with calibrated strain gages cemented to cantilever weigh-beams. Voltages of the strain-gage circuit were recorded on self-balancing potentiometers. The precision of these measurements, including variation of calibration constants and interpretation of chart readings, was better than 1.5 percent in propellant flows and 2 percent in thrust measurement. Propellant injection pressure and combustion-chamber pressure were measured by Bourden tube-type pressure recorders. The outputs of iron-constantan thermocouples were recorded on self-balancing potentiometers and were used to determine the temperatures of the propellants and coolant water. These temperatures were accurate to within 2 percent.

The combustion-chamber coolant flow was measured with a variable-area orifice meter to an accuracy within 2 percent. The turbulence-coil coolant flow was determined from a calibration of flow against the pressure applied to the coolant supply tank.

PROCEDURE

Engine Operation

Liquid ammonia was loaded into the fuel supply tank directly from the commercial supply cylinder after all valves and fittings in the entire setup were pressure-checked and purged with dry helium.

Gaseous fluorine, from a remotely opened cylinder, was condensed in the liquid-nitrogen-cooled oxidant supply tank. Condensing operations were enhanced by the addition of a trap, surrounded by a dry ice - alcohol bath, to remove hydrogen fluoride from the gaseous fluorine. After the condensing operation, both propellant tanks were pressurized while a precooling flow of liquid nitrogen was passed through the fluorine flow system. The precooling operation was stopped and the fluorine flow valve opened, followed immediately by the opening of the ammonia flow valve. After several runs, the firing procedure was altered to permit the introduction of the ammonia first, during the last few seconds of the liquid-nitrogen precooling operation, and then the liquid-nitrogen flow was stopped and the fluorine flow begun immediately. When the propellant tanks were emptied, both systems were purged with helium.

This fluorine-handling and firing procedure was later modified to obtain more data in less time. The modification provided a six-cylinder fluorine manifold and semi-remote operation. The first cylinder of fluorine was condensed remotely as was described above, after which the cylinder valve was closed. If no difficulty was encountered, the operator approached the outside of the barrier and, reaching over the top with a long-handled wrench, opened as many of the remaining five cylinders as were required. Condensing proceeded from these cylinders simultaneously.

The larger supply of fluorine permitted a series of runs with a single loading. The firing procedure for the first run of the series was started as described previously. After approximately 20 seconds of running, both propellant valves were closed simultaneously. Since subsequent runs were made immediately after resetting injection pressures, there was no need for further line cooling. The fuel valve was opened to start the next run and was followed immediately by the opening of the oxidant valve. As many as four successive runs have been made following this procedure.

Data Presentation

The theoretical data presented in this report were obtained from reference 5 and are based on equilibrium composition expansion.

Experimental values of specific impulse were calculated from measured thrust and propellant flow rates and were considered to be precise within 3 percent. Corrections were applied to the experimental data for heat rejection to chamber walls and to the turbulence coil as well as for deviations in chamber pressure from the base of 300 pounds per square inch absolute.

The specific impulse corrected for total heat rejection is a function of the measured heat rejection and the ideal thermodynamic cycle efficiency, $(1 - T_e/T_c)$, and is given by the equation

$$I_h = \sqrt{I_{ex}^2 + \frac{2JQ\eta}{g}}$$

The correction for chamber-pressure variation was then added to the heat-corrected specific impulse. The correction is based on the theoretical increase in specific impulse with increased chamber pressure at optimum area ratios (ref. 6), and is given by the equation

$$I_{ex} - I_p = K \log (P_c/300)$$

where K is the approximate slope of the curve of I against $\log P_c$ and is equal to 88.65 for this propellant combination. Figure 6 is a curve of these corrections plotted against $\log P_c$.

The experimental chamber pressure together with thrust and propellant flows provided the means for calculating characteristic velocity and thrust coefficient to a precision within 3 percent.

The heat-rejection values presented were an average over the entire combustion chamber, nozzle included, and were taken as the product of coolant specific heat, flow rate, and inlet and outlet temperature difference.

RESULTS AND DISCUSSION

Specific Impulse

The experimental data are presented in table II. Figure 7(a) shows experimental specific impulse as a function of weight percent fuel for four of the injectors used; the theoretical curve is presented for comparison. The curves indicate that the maximum experimental performance was obtained with the triplet-type 4(2-1) injector using a 50 L* engine. Peak specific impulse with this injector was 270 pound-seconds per pound at 29 percent fuel, approximately 87 percent of the theoretical maximum of 311 pound-seconds per pound at 24 percent fuel. (This peak value corresponds to about 94 percent of the theoretical maximum based on frozen composition expansion.) The shape of the experimental curve indicates that the efficiency of the injector, as compared with others, is relatively independent of fuel percentage. Significantly, the faired curve indicates that a specific impulse of about 250 pound-seconds per pound is still obtainable at fuel percentages as high as 40. This region may be of interest when the design of a self-cooled rocket engine is considered, since ammonia is the more obvious coolant of this combination.

The high performance of the 4(2-1) in the fuel-rich region is in sharp contrast to the abrupt decrease in efficiency of the 8(1-1)CA impinging-jet injector on either side of the peak performance of 264 pound-seconds per pound at 29 percent fuel. Similar results were observed in reference 2, where it was suggested that the variation of efficiency with fuel percentage for this injector was due to a dependence on resultant angle of the impinging streams. Several runs made with the modified turbulence coil, 8(1-1)CB, revealed no measurable increase over the performance of the 8(1-1)CA configuration. Although a difference in efficiency would possibly have become apparent had a greater number of runs been made with both types of turbulence promoter, it was evident that neither of the coils would have increased the efficiency of the 1-1 configurations to that of the 4(2-1).

Three check runs made with the showerhead injector in a 100 L* chamber gave extremely low performance, as was expected when the results reported in reference 2 were considered. The highest specific impulse obtained was only about 225 pound-seconds per pound at 33 percent fuel.

The corrected curves of specific impulse, shown in figure 7(b), indicate no significant difference from the trends established by the experimental data. The maximum corrected value for the 4(2-1) injector was 275 pound-seconds per pound at 28 percent fuel, an increase of 2 percent over the uncorrected value. The maximum value for the 8(1-1)CA and 8(1-1)CB injectors was increased 3 percent by the corrections to a value of 272 pound-seconds per pound at 29 percent fuel.

Characteristic Velocity

The curves of experimental characteristic velocity C^* against weight percent fuel, as presented in figure 8, show again that maximum performance was obtained with the 4(2-1) injector, although the difference between the maximum with this injector and that of the 8(1-1)CA and 8(1-1)CB injectors was not significantly large. The values were 6600 and 6550 feet per second, respectively, or about 93 percent of the theoretical maximum. The peaks in the curves, however, occurred at 32 percent fuel with the 4(2-1) and at 27 percent with the 8(1-1)CA and 8(1-1)CB injectors.

No C^* values higher than 5560 feet per second were obtained with the showerhead injector in a 100 L* chamber.

Thrust Coefficient

Thrust-coefficient values for the chamber nozzles used reached a maximum value of 1.31, 92 percent of the theoretical maximum based on equilibrium composition expansion, as shown in figure 9. The low values may be due, as was suggested in reference 2, to nonequilibrium expansion through the engine nozzle.

Heat Rejection

Average total heat-rejection values for the 4(2-1) injector were only slightly higher than those for the 8(1-1)CA and 8(1-1)CB injectors, as shown by figure 10 (a reference curve of combustion temperature is also included). Values varied from 2.5 to 3.1 Btu/(sec)(sq in.) for the 4(2-1) and from 2.4 to 2.7 Btu/(sec)(sq in.) for the 8(1-1)CA and 8(1-1)CB over the range of 20 to 40 percent fuel. The showerhead injector produced the lowest heat-rejection values, 0.9 to 1.1 Btu/(sec)(sq in.).

Burn-outs occurred with two injectors within 3 seconds of the start of the runs. The center face of the 6(2-1) injector (fig. 5(d)) burned through despite efforts to cool the face by diverting a portion of the oxidant flow through small holes drilled in this face. A comparison of the dimensions of this injector with those of the 4(2-1) (see table I) shows that the 6(2-1) injector had a shorter impingement length and shorter distance from impingement point to engine axis. In addition, the external manifolding of the two fluorine chambers in the 6(2-1) (fig. 5(d)) resulted in a 50-50 distribution of fluorine to the two chambers, as opposed to the internal manifolding (fig. 5(a)) used for the 4(2-1), which provided for 63 percent of the fluorine flow through the inner chamber. Any one, or combination, of these differences could have resulted in the burning out of the 6(2-1) injector.

An examination of the double-cone injector after attempted runs revealed several holes burned in the injector face between the drilled oxidant orifices.

Operational Notes

Low-frequency fluctuations of thrust, chamber pressure, and propellant-injection pressures were evidenced in runs with the 4(2-1) injector at mixture ratios greater than 28 percent fuel. The chamber-pressure oscillations were first noticed on records obtained with a Bourden-tube pressure recorder (fig. 11) and were later substantiated by pressure measurements made with variable-reluctance pressure pickups. The indicated frequency of the fluctuations was very low, approximately 2 to 4 cycles per second. Although the instrumentation used was not suitable for an accurate determination of the amplitude, it indicated a trend of increased amplitude with increased fuel percentage to a peak-to-peak value of the order of 60 pounds per square inch at 50 percent fuel.

Attempts to determine the source of these very-low-frequency pressure disturbances were not successful. Cold-flow tests made under simulated run conditions failed to exhibit any fluctuations in propellant injection pressures. Differential pressures of the propellants across this injector were between 100 and 200 pounds per square inch, which would tend to inhibit any coupling between the combustion chamber and propellant supply systems. It appears that the oscillations are associated with this particular triplet injector and could probably be eliminated by a different triplet design.

Rough starts, erratic chamber pressure and thrust buildup, were observed at the outset of the investigation. (Similar observations are reported in ref. 3.) The firing procedure at that time called for a short fluorine lead into the chamber. An extended oxidant lead of approximately 2 to 3 seconds resulted in an explosion in the rocket

chamber when the fuel was introduced. The firing procedure was then altered to provide a definite fuel lead. Runs made under these conditions produced smooth starts with fuel leads as long as 3 to 4 seconds, as shown by the thrust record reproduced in figure 12(a). (Liquid-nitrogen flow was maintained in the fluorine line during the fuel lead to prevent ammonia from backing up into the fluorine system.) Figure 12(b) shows, by comparison, the thrust record of a run started with an oxidant lead. A more detailed investigation of this phenomenon should reveal its exact nature and establish a recommended starting technique.

Chamber deposits, (in small quantities), probably consisting of ammonium fluoride for the most part, were observed when ammonia was permitted to flow through the chamber after the fluorine flow had expired. Arrangements were made in several runs to provide a fluorine override. Examination of the combustion chamber and injector after these runs revealed only traces of the deposit. Again, only traces of the deposit were in evidence when both fluorine and ammonia flow were halted simultaneously.

SUMMARY OF RESULTS

The results of the investigation of the liquid fluorine - liquid ammonia propellant combination in 100-pound-thrust rocket engines, operating at a chamber pressure of 300 pounds per square inch absolute, can be summarized as follows:

1. Maximum experimental performance was obtained with a triplet-type two-oxidant-on-one-fuel impinging-jet injector, with four sets of holes, run with chambers of 50-inch characteristic length. The peak experimental specific impulse obtained was 270 pound-seconds per pound at 29 percent fuel - 87 percent of the theoretical maximum. This value was increased to 275 pound-seconds per pound by corrections for heat rejection to engine walls and chamber-pressure variation from a base of 300 pounds per square inch absolute. The maximum value of characteristic velocity for this injector was 6600 feet per second at 32 percent fuel - 93 percent of the theoretical. Average total heat-rejection values varied from 2.5 to 3.1 Btu/(sec)(sq in.) in the range of 20 to 40 percent fuel.
2. A one-oxidant-on-one-fuel impinging-jet injector fitted with a turbulence-promoting coil and run with chambers of 50-inch characteristic length produced a maximum specific impulse value of 264 pound-seconds per pound. The best value of characteristic velocity obtained was 6550 feet per second. Heat-rejection values ranged from 2.4 to 2.7 Btu/(sec)(sq in.) in the region of 20 to 40 percent fuel. A modification of the coil resulted in no measurable increase in performance.

3. Three runs made with a showerhead-type injector with a chamber of 100-inch characteristic length gave low performance. The highest specific-impulse value obtained was 225 pound-seconds per pound.

4. The maximum value of thrust coefficient obtained for the nozzles used was 1.31, 92 percent of the theoretical value.

5. Injector burn-outs occurred within 3 seconds of the start of the runs with a triplet-type injector with six sets of holes and an injector consisting of a conical array of fuel jets impinging inside a similar cone of oxidant jets.

6. Erratic buildup of thrust and chamber pressure was observed in several runs in which the fluorine was introduced into the combustion chamber before the ammonia. Runs made with a fuel lead were generally smooth-starting.

7. Small amounts of a white deposit, probably ammonium fluoride, were noticed on the rocket-injector face and combustion-chamber walls after runs in which ammonia flow was continued into the chamber after the fluorine flow had expired. Only traces of this deposit were in evidence when either fluorine was in excess or both fuel and oxidant flows were halted simultaneously.

CONCLUDING REMARKS





The results of the experimental investigation show that specific-impulse values as high as 87 percent of the theoretical based on equilibrium composition expansion are attainable with conventional injector designs. It is felt that still higher impulse values can be achieved with further investigation of various injector and nozzle configurations. This work can be facilitated and accelerated by operation at higher thrust levels which would offer a greater degree of flexibility in such injector and engine studies.

Lewis Flight Propulsion Laboratory
National Advisory Committee for Aeronautics
Cleveland, Ohio, April 20, 1953

REFERENCES



1. Ordin, Paul M., Douglass, Howard W., and Rowe, William H.: Investigation of the Liquid Fluorine - Liquid Diborane Propellant Combination in a 100-Pound-Thrust Rocket Engine. NACA RM E51I04, 1951.
2. Ordin, Paul M., Rothenberg, Edward A., and Rowe, William H.: Investigation of Liquid Fluorine and Hydrazine-Ammonia Mixture in 100-Pound-Thrust Rocket Engine. NACA RM E52H22, 1952.
3. Hatcher, John B.: A Preliminary Investigation of the Liquid Fluorine-Liquid Ammonia System. Prog. Rep. No. 1-80, Jet Propulsion Lab., C.I.T., Apr. 14, 1952. (Power Plant Lab. Proj. No. MX801, Contract No. W535-ac-20260, Air Materiel Command; ORDCIT Proj. Contract No. DA-04-495-Ord 18, Dept. Army, Ord. Corps.)
4. Doyle, William L.: Experimental Evaluation of the Liquid Ammonia-Liquid Fluorine Propellant Combination at Various Chamber Pressures. Tech. Rep. No. 6, Proj. RF-333, Cryogenic Lab., Dept. Chem., Ohio State Univ. Research Foundation, Columbus (Ohio), Nov. 1, 1951. (Air Force Contract W33-038-ac-19382(19126).)
5. Gordon, Sanford, and Huff, Vearl N.: Theoretical Performance of Liquid Ammonia and Liquid Fluorine as a Rocket Propellant. NACA RM E53A26, 1953.
6. Morrell, Virginia E.: Effect of Combustion-Chamber Pressure and Nozzle Expansion Ratio on Theoretical Performance of Several Rocket Propellant Systems. NACA RM E50C30, 1950.

TABLE I. - CHARACTERISTICS OF LIQUID FLUORINE - LIQUID AMMONIA INJECTORS USED WITH 100-POUND-THRUST ROCKET ENGINES

Injector	Number of orifices		Orifice diameter, in.		Angle of jet to engine axis, deg		Jet length from orifice to point of impingement, in.		Distance from points of impingement to engine axis, in.	Distance from points of impingement to plane of center face, in.	Thickness of face, in.	Material
	F ₂	NH ₃	F ₂	NH ₃	F ₂	NH ₃	F ₂	NH ₃				
4(2-1) 	8	4	0.022	0.033	45	0	0.399	0.408	0.688	0.187	0.094	Nickel
8(1-1)CA 8(1-1)CB 	8	8	.034	.023	0	60	.249	.244	.312	.249	.085	Nickel
Shower-head 	22 ^a 44 ^b	22	.018 ^a .012 ^b	.011	0 0	0	-----	-----	-----	-----	.065	Nickel
6(2-1) 	6 ^a 6 ^b 7 ^c	6	.025 ^a .025 ^b .016 ^c	.029	45 45 0	0	.234 ^a .139 ^b	.250	.575	.066	.065	Nickel
Double cone 	8	8	.031	.018	45	20	1.037	.762	0	.755 ^d	.083	Stainless steel

^aInner fluorine orifices.^bOuter fluorine orifices.^cCenter-face coolant orifices.^dInner jet cone.

TABLE II. - SUMMARY OF EXPERIMENTAL PERFORMANCE OF LIQUID FLUORINE - LIQUID AMMONIA PROPELLANT COMBINATION

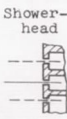
Injector design	Engine characteristic length, L^* , in.	Run time, sec	Weight-percent fuel	Total propellant flow, lb/sec	Thrust, lb	Specific impulse, I_{ex} , lb-sec/lb	Combustion-chamber pressure, P_c , lb/sq in. abs	Total heat transfer, Q_c , Btu/sec	Corrected specific impulse, $I_{h,p}$, lb-sec/lb	Characteristic velocity, C^* , ft/sec	Thrust coefficient, C_F	Average heat-rejection rate to engine, Btu/(sec) (sq in.)	Average heat-rejection rate to coil, Btu/(sec) (sq in.)	Total average heat-rejection rate, Btu/(sec) (sq in.)		
	50	23	17.57	0.3811	92.78	243.5	295	75.03	255.2	5884	1.333	2.626	(a)	2.626		
		26	19.17	.3334	82.65	247.9	275	65.82	259.6	6268	1.273	2.304	(a)	2.304		
		27	24.40	.3419	87.95	257.2	285	79.35	265.5	6335	1.308	2.777	(a)	2.777		
		23	24.49	.3513	93.38	265.8	292	82.02	273.0	6316	1.355	2.871	(a)	2.871		
		14	25.64	.3083	84.58	274.3	285	99.08	285.0	7025	1.258	3.468	(a)	3.468		
		19	26.53	.3696	96.08	260.0	305	98.06	267.3	6271	1.335	3.432	(a)	3.432		
		23	27.58	.3985	106.3	266.8	325	51.97	267.7	6486	1.324	1.819	(a)	1.819		
		25	27.59	.3979	102.5	257.6	329	70.40	259.6	6283	1.320	2.464	(a)	2.464		
		21	27.66	.3451	93.15	269.9	295	83.88	277.9	6496	1.338	2.936	(a)	2.936		
		25	27.89	.3542	94.50	266.8	310	96.94	273.9	6651	1.292	3.394	(a)	3.394		
		22	29.09	.3726	104.9	281.5	319	64.19	284.3	6506	1.393	2.247	(a)	2.247		
		6	30.78	.3548	96.46	271.9	313	86.80	278.2	6704	1.306	3.039	(a)	3.039		
		27	31.87	.3313	84.30	254.5	277	94.80	267.8	6354	1.290	3.318	(a)	3.318		
		39	32.03	.3297	85.12	258.2	285	88.91	269.7	6569	1.266	3.112	(a)	3.112		
		21	33.40	.3488	91.77	263.1	302	91.05	272.2	6580	1.288	3.188	(a)	3.188		
		16	34.11	.3627	96.02	264.7	314	79.03	270.9	6579	1.296	2.767	(a)	2.767		
		58	36.36	.3597	95.02	264.2	300	79.57	272.7	6338	1.342	2.786	(a)	2.786		
		10	38.63	.4076	104.2	255.6	350	87.12	258.7	6525	1.262	3.049	(a)	3.049		
		8	40.00	.4155	108.8	261.2	357	101.1	264.8	6514	1.291	3.539	(a)	3.539		
		21	44.15	.3837	85.08	221.7	285	78.75	234.6	5644	1.265	2.757	(a)	2.757		
		9	46.25	.5047	104.4	206.9	340	80.85	211.4	5119	1.301	2.830	(a)	2.830		
		19	46.79	.4185	94.60	226.0	320	70.94	232.7	5811	1.253	2.483	(a)	2.483		
		21	50.71	.3993	85.86	215.0	280	98.13	231.4	5329	1.299	3.436	(a)	3.436		
		16	58.39	.3922	76.48	195.0	255	63.37	(b)	4941	1.271	2.219	(a)	2.219		
			50	14	18.16	.4392	85.86	195.5	272	65.25	213.7	4926	1.278	2.284	3.204	2.609
				14	20.30	.4209	99.43	236.2	327	94.50	243.6	5904	1.288	3.308	2.868	3.189
				16	25.31	.3649	97.52	267.3	305	9.85	270.4	6648	1.294	.345	3.716	1.257
				18	28.34	.3899	100.2	257.0	325	93.28	264.1	6334	1.306	3.265	2.868	3.158
18	32.87			.3879	101.6	261.9	305	58.20	269.9	6254	1.349	2.037	3.342	2.390		
11	38.33			.4524	99.47	219.9	325	93.56	228.3	5459	1.297	3.275	1.321	2.747		
	50	15	17.68	.4430	90.73	204.8	295	58.79	216.8	5296	1.245	2.058	2.645	2.174		
		15	25.69	.3828	97.94	255.9	310	34.52	258.9	6441	1.279	1.208	2.935	1.551		
		24	27.54	.3743	99.08	264.7	(c)	92.20	-----	-----	-----	-----	3.227	3.966	3.373	
		24	27.86	.3615	98.23	271.7	310	90.29	280.1	6627	1.320	3.160	3.777	3.283		
	100	16	26.29	.4214	85.17	202.1	280	68.83	211.0	5285	1.231	1.383	(a)	1.383		
		19	33.34	.4397	99.14	225.5	301	28.13	228.1	5445	1.333	.565	(a)	.565		
		20	38.14	.3757	80.65	214.7	263	77.28	230.0	5568	1.242	1.552	(a)	1.552		

^a Turbulence coil not incorporated in injector design.
^b No theoretical chamber and exit temperatures calculated.
^c No chamber-pressure record obtained.

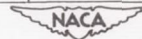

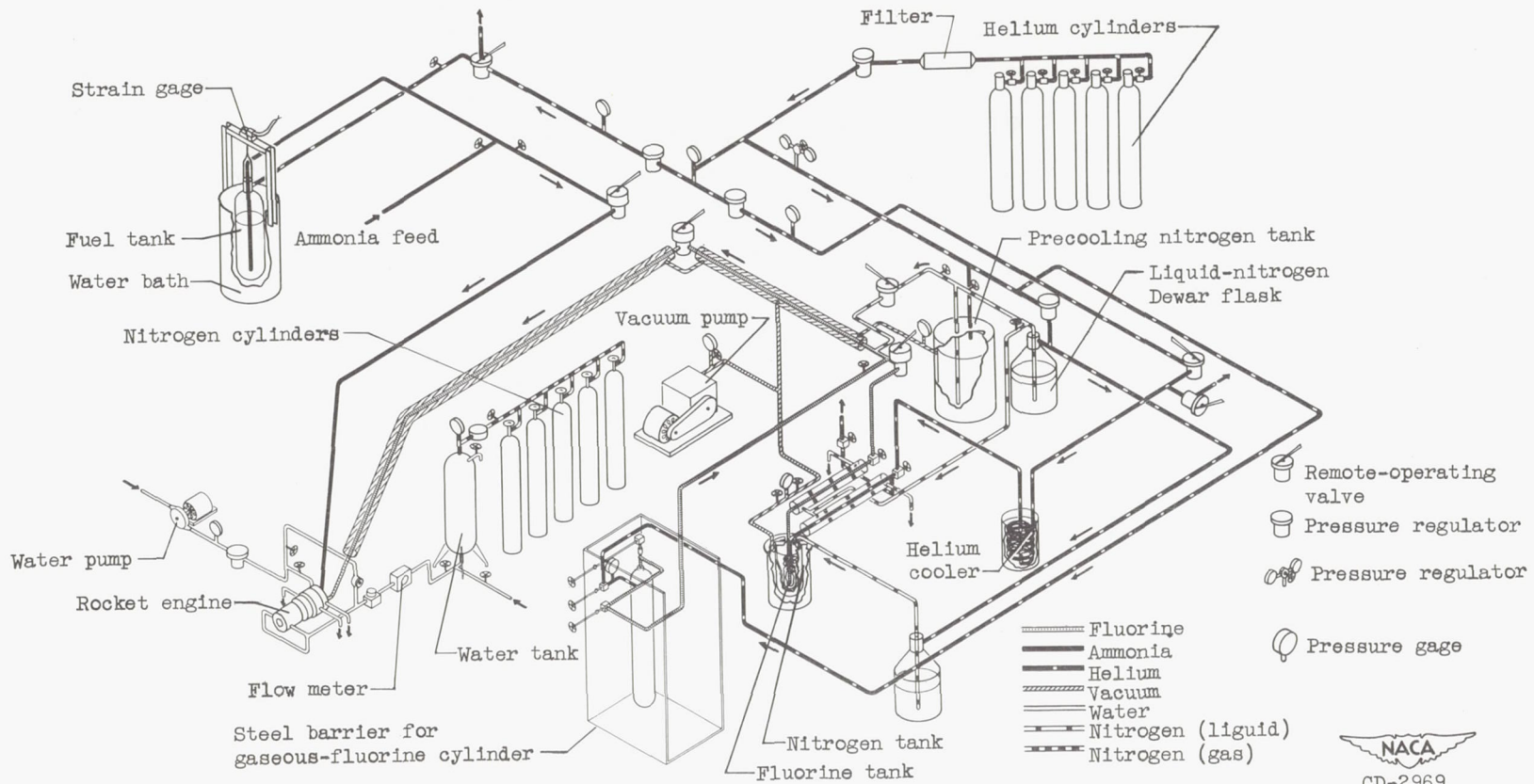

Figure 1. - Diagrammatic sketch of apparatus for 100-pound-thrust rocket engine for investigation of liquid fluorine-liquid ammonia propellant combination.

NACA
CD-2969

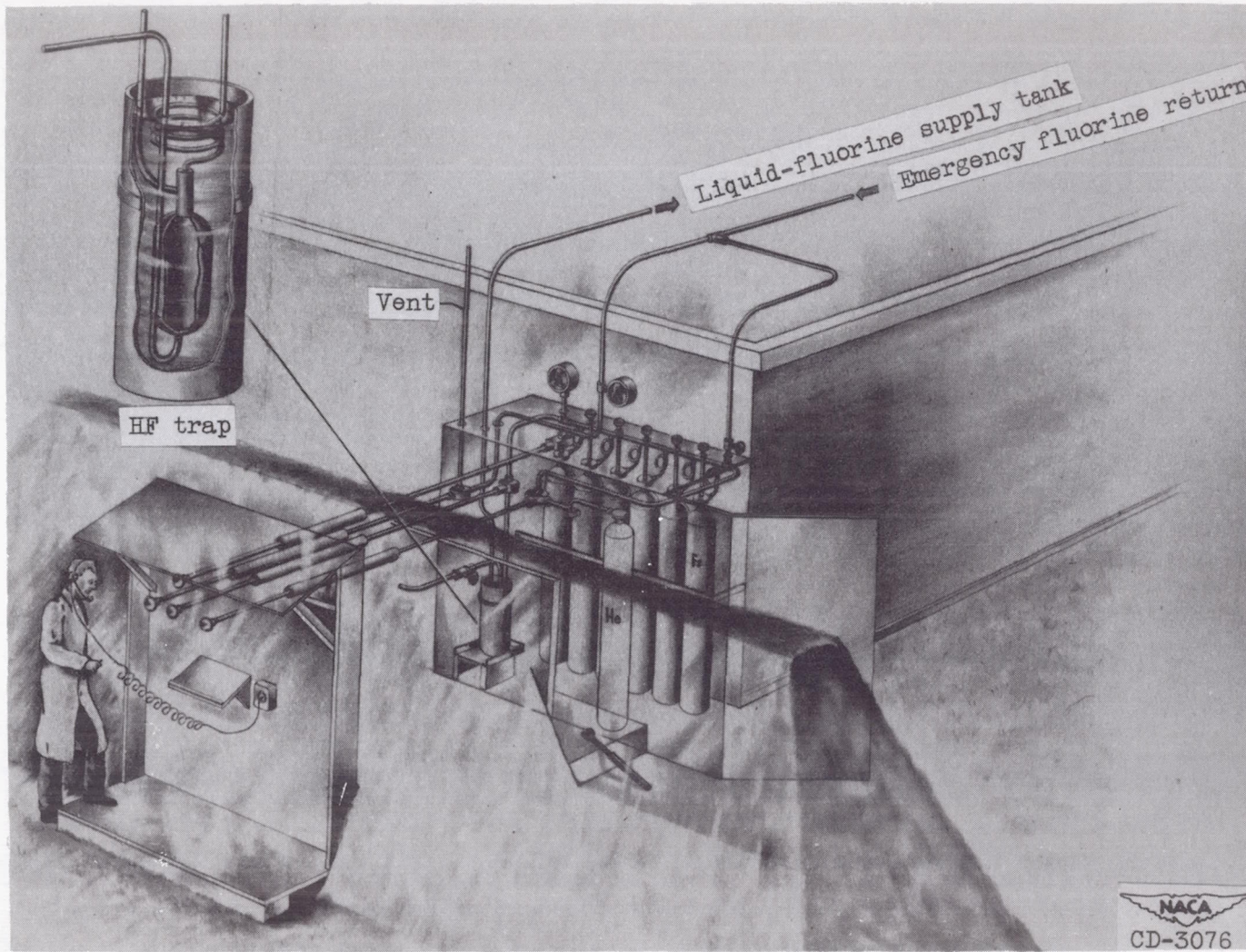
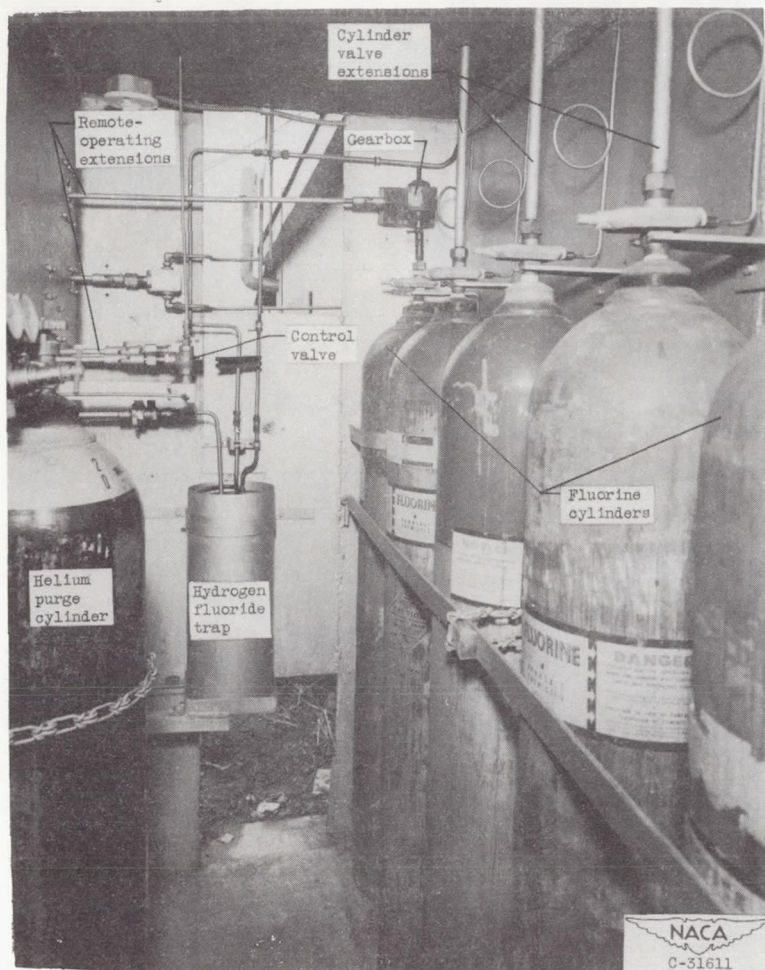
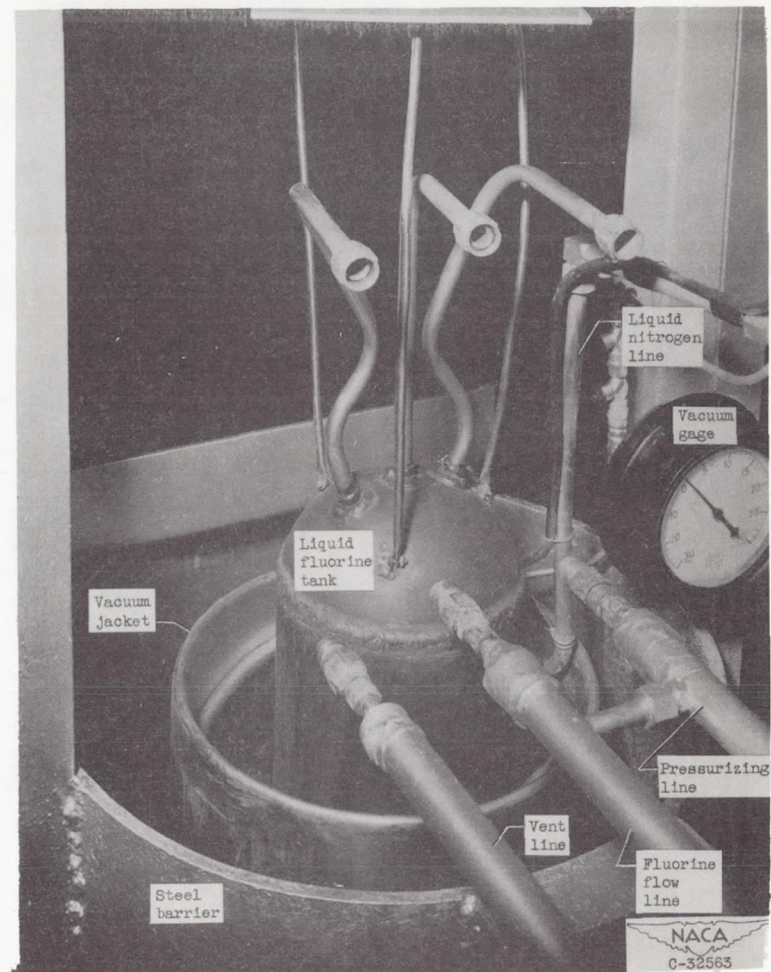

Figure 2. - Gaseous-fluorine supply system.



(a) Gaseous-fluorine supply cylinder manifold.



(b) Liquid-fluorine supply tank.

Figure 3. - Apparatus for investigation of liquid fluorine - liquid ammonia propellant combination in 100-pound-thrust rocket engines.

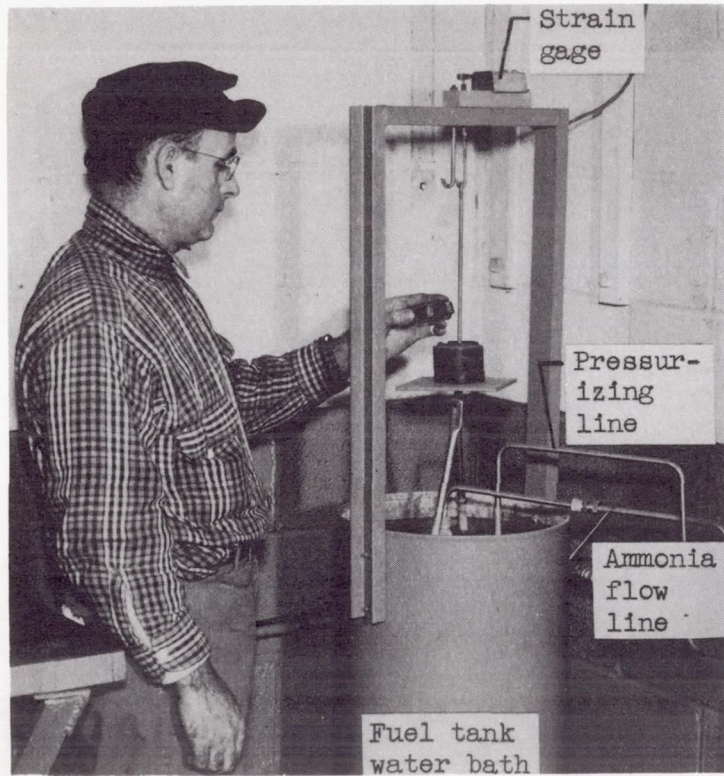

(c) Fuel supply tank.

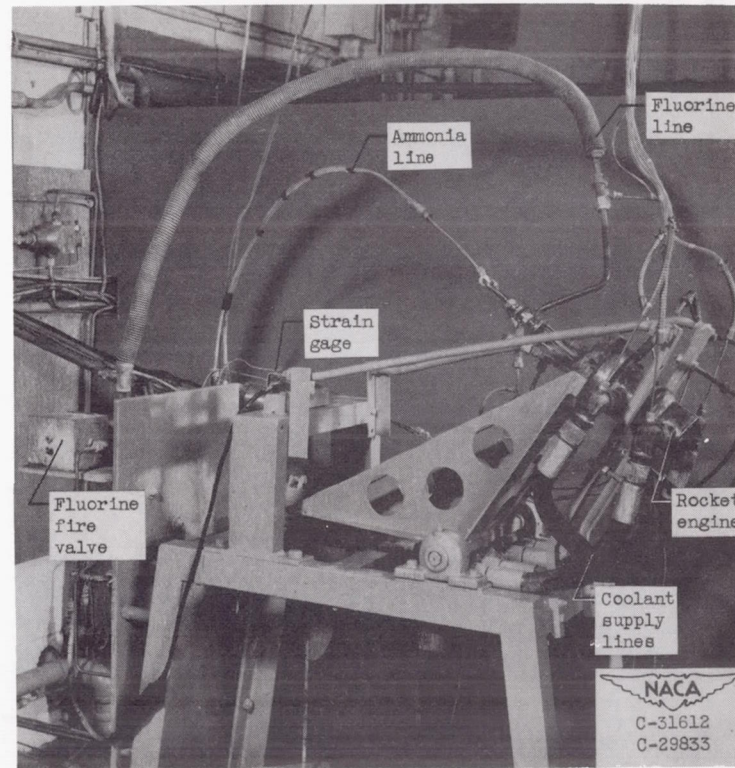

(d) Thrust stand with mounted rocket engine.

Figure 3. - Concluded. Apparatus for investigation of liquid fluorine - liquid ammonia propellant combination in 100-pound-thrust rocket engines.

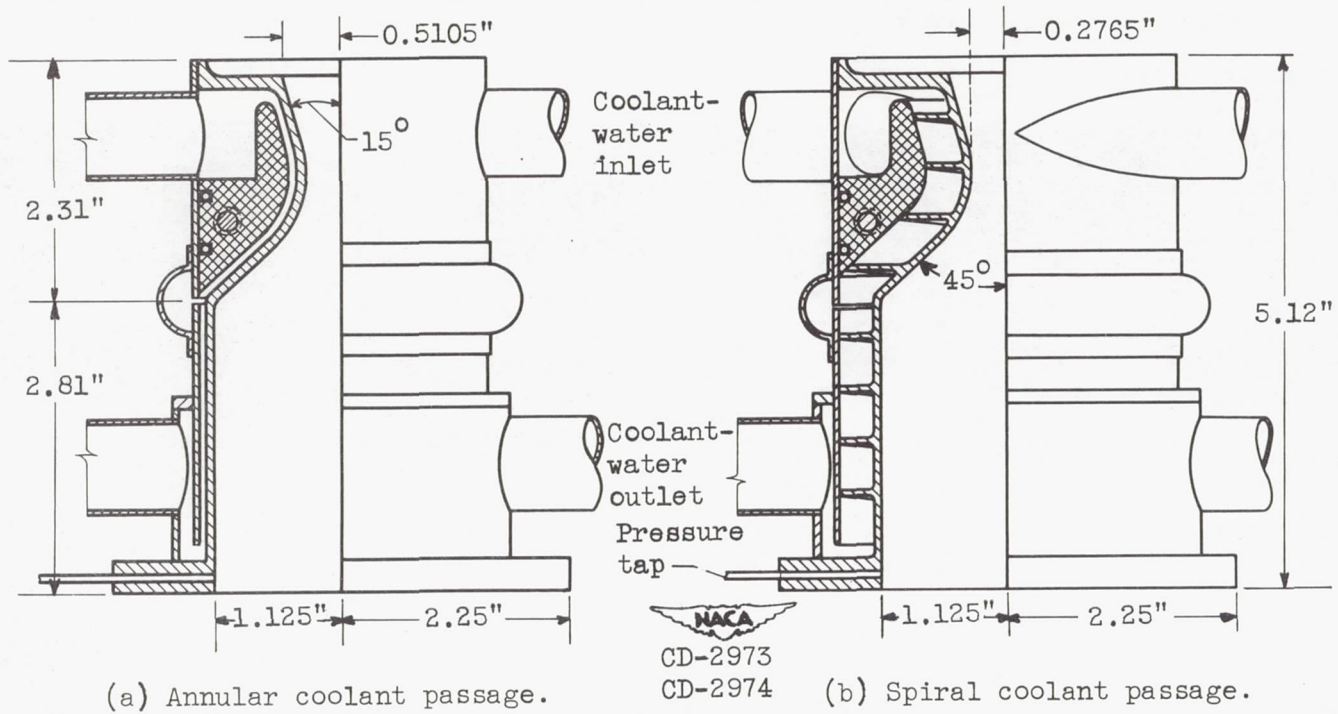
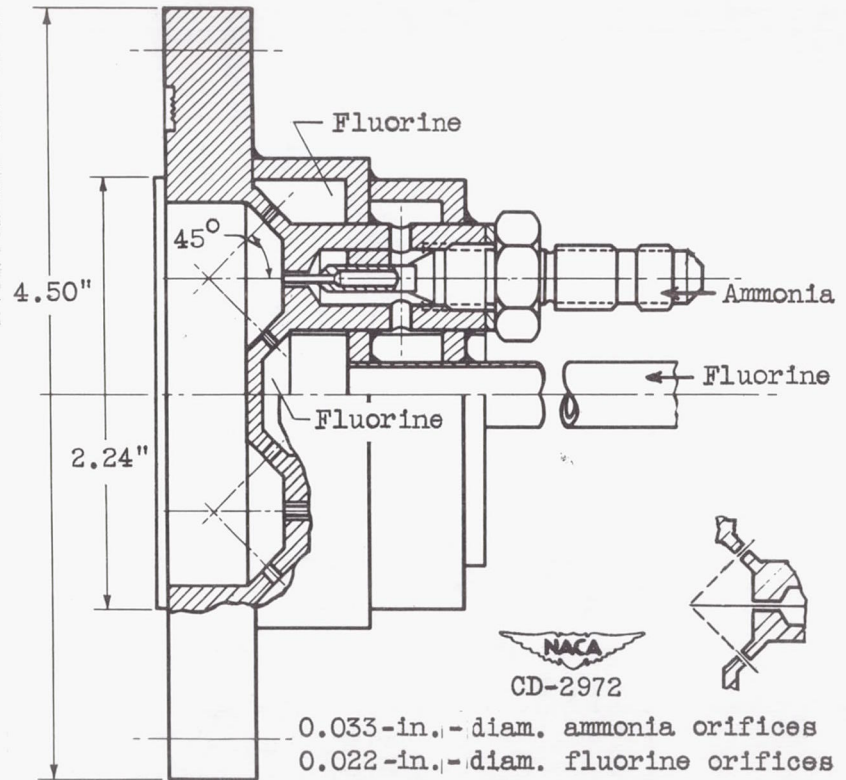
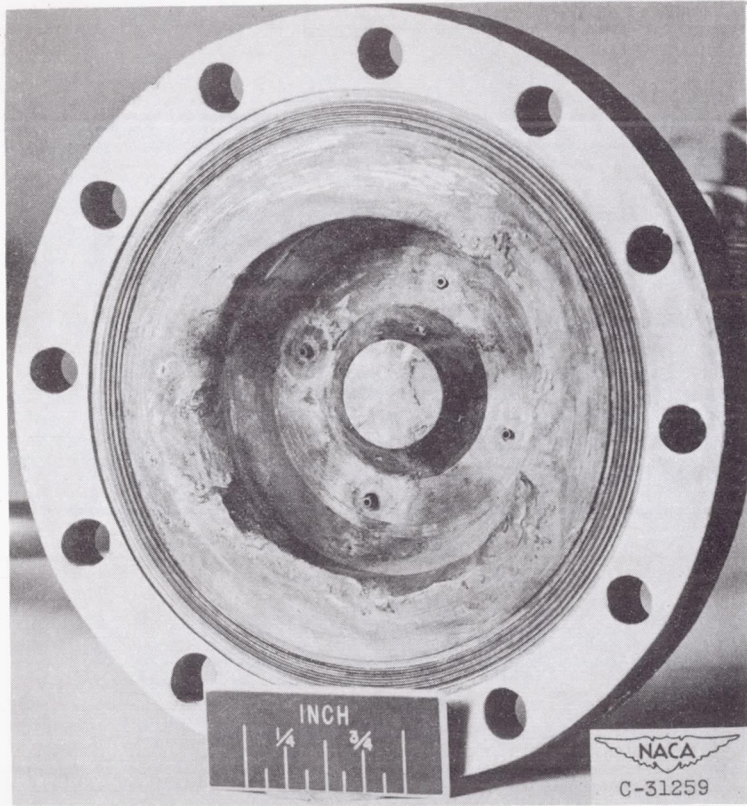
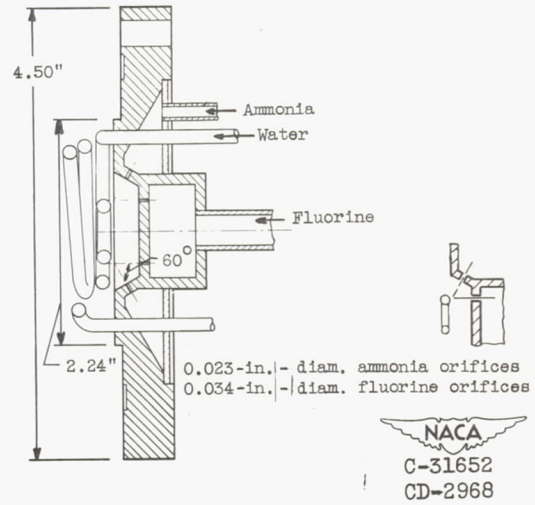
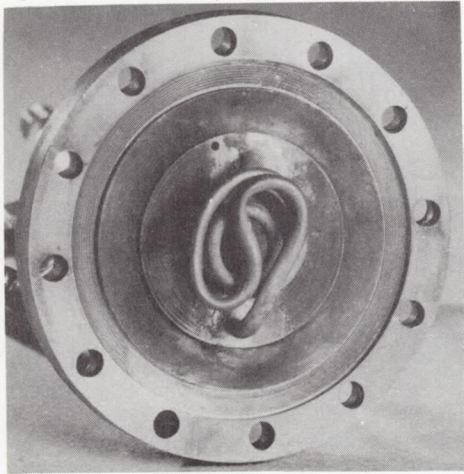

Figure 4. - Diagrammatic sketches of combustion chamber and nozzle assemblies of engines of 50-inch characteristic length.



(a) Impinging-jet injector providing for four sets of two-oxidant-on-one-fuel jets (4(2-1)).

Figure 5. - Injectors investigated.



(b) Impinging-jet injector providing for eight sets of one-oxidant-on-one-fuel jets with turbulence coil A (8(1-1)CA).

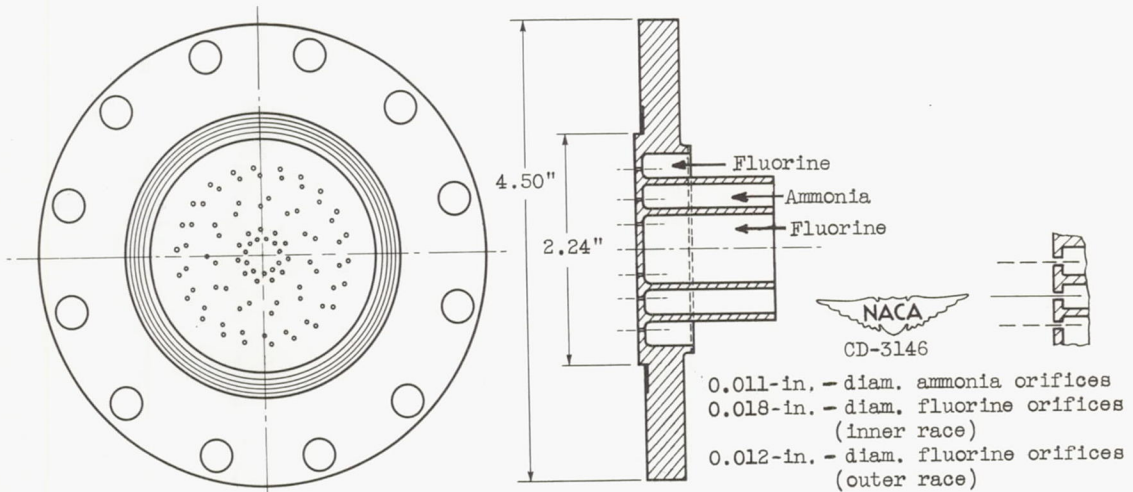

(c) Showerhead injector with 66 oxidant orifices and 22 fuel orifices.

Figure 5. - Continued. Injectors investigated.

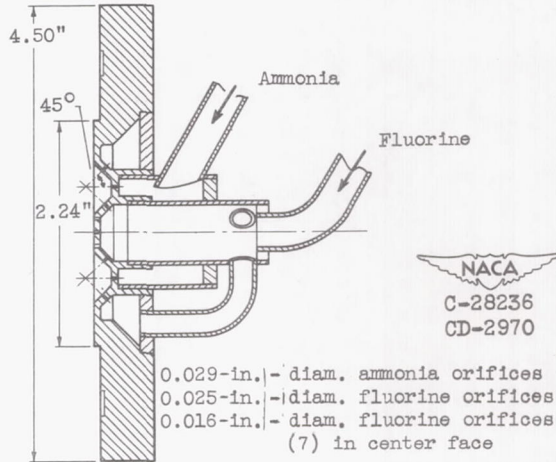
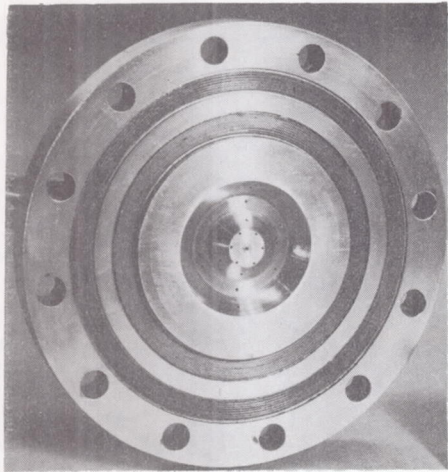

(d) Impinging-jet injector providing for six sets of two-oxidant-on-one-fuel jets with center face coolant holes (6(2-1)).

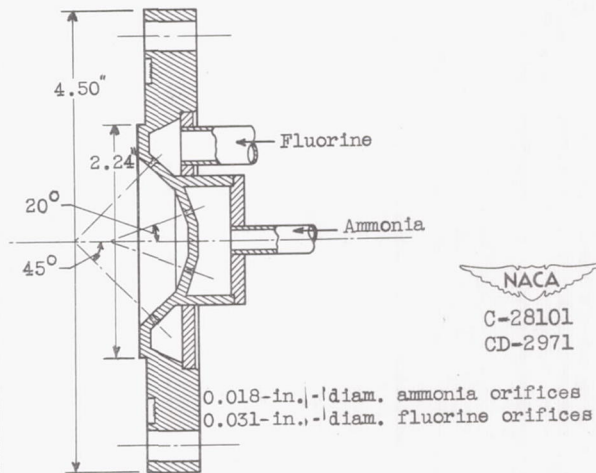
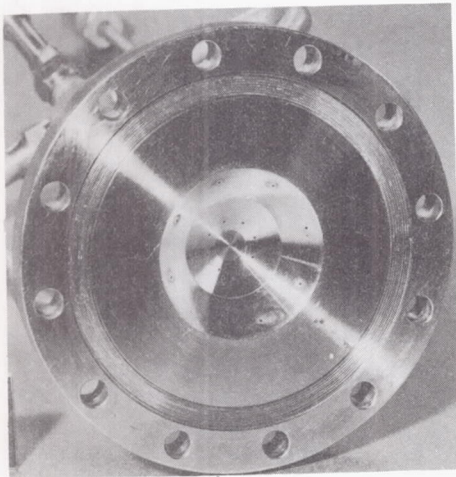

(e) Double-cone injector. Impinging-jet injector providing for impingement of eight fuel jets at common point inside concentric cone formed by eight oxidant streams.

Figure 5. - Concluded. Injectors investigated.

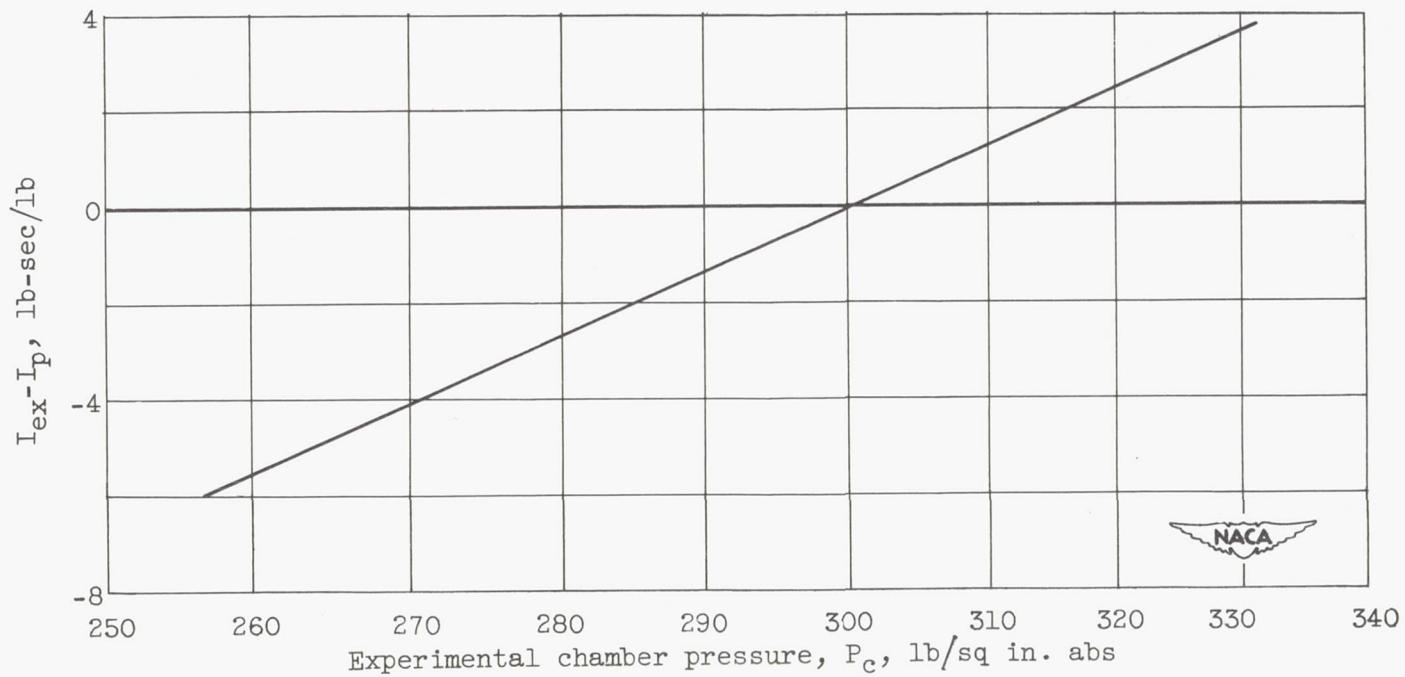
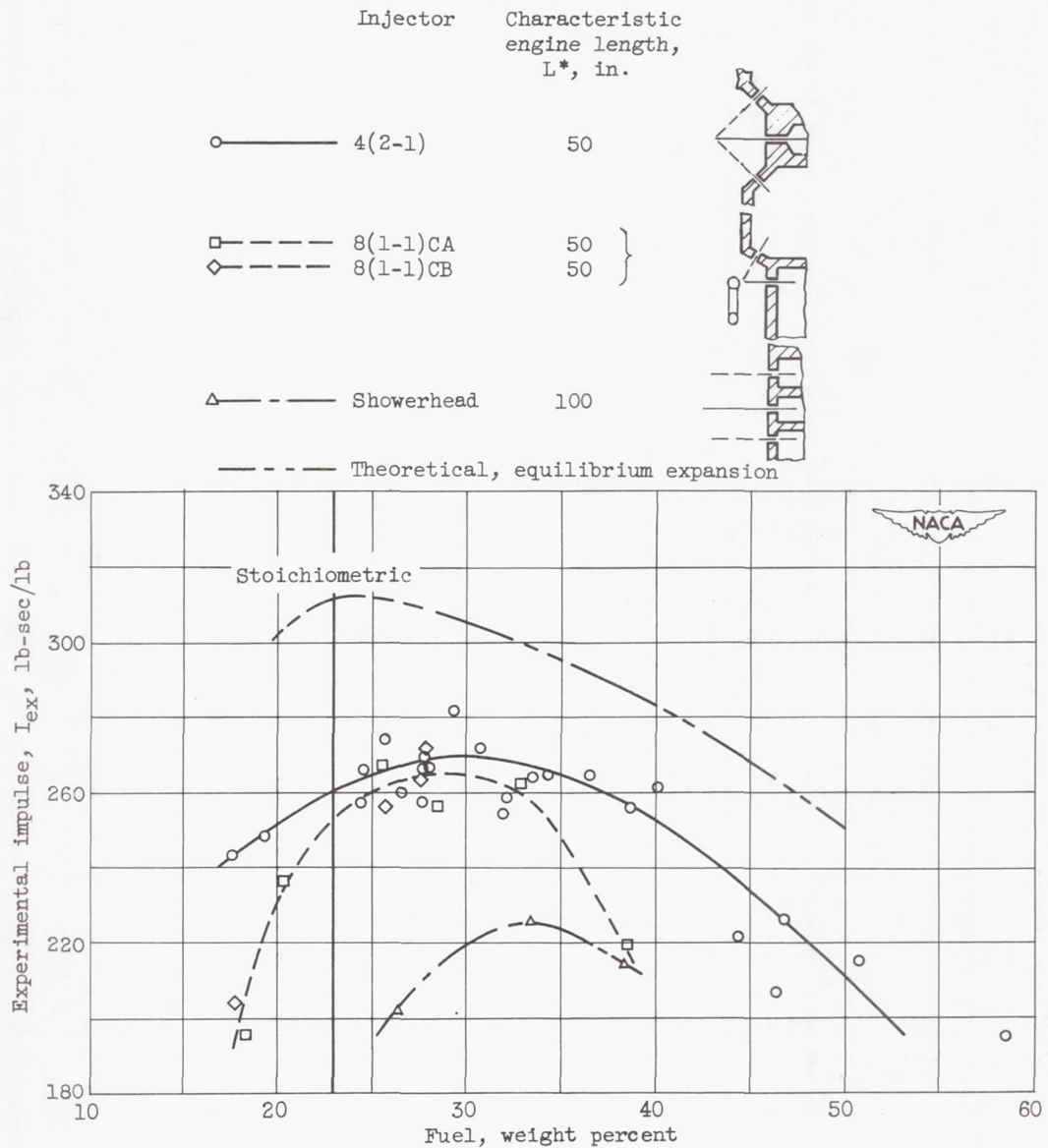

Figure 6. - Theoretical variation of specific impulse with chamber pressure from base of 300 pounds per square inch absolute for liquid fluorine - liquid ammonia propellant combination for ideal nozzle. $I_{ex} - I_p = 88.65 \log(P_c/300)$.

CY-4



(a) Comparison of measured and calculated values.

Figure 7. - Theoretical and experimental specific impulse of liquid fluorine - liquid ammonia in 100-pound-thrust rocket engines. Chamber pressure, 300 pounds per square inch absolute.

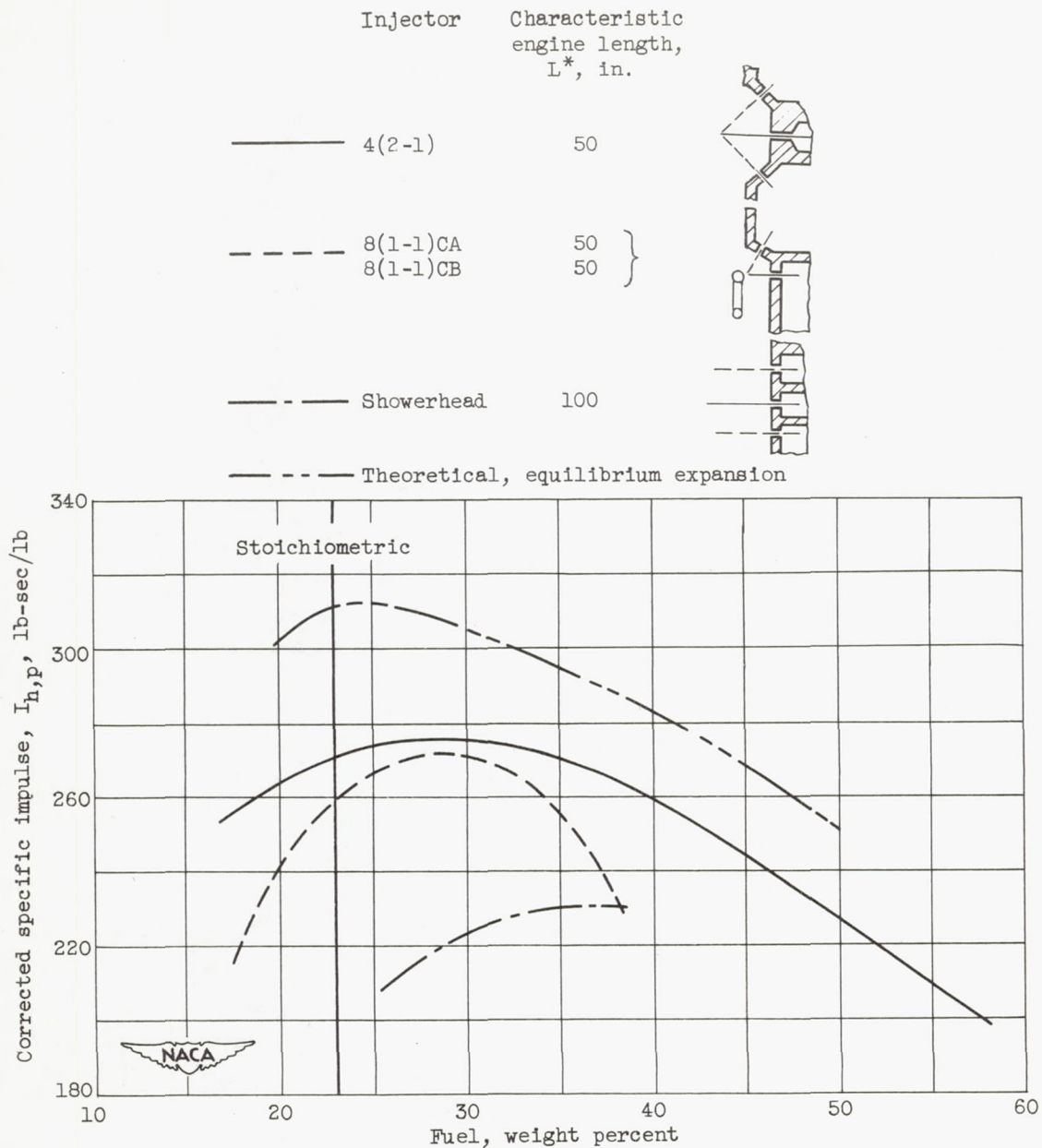

(b) Comparison of calculated and corrected experimental values.

Figure 7. - Concluded. Theoretical and experimental specific impulse of liquid fluorine - liquid ammonia in 100-pound-thrust rocket engines. Chamber pressure, 300 pounds per square inch absolute.

CY-4 back

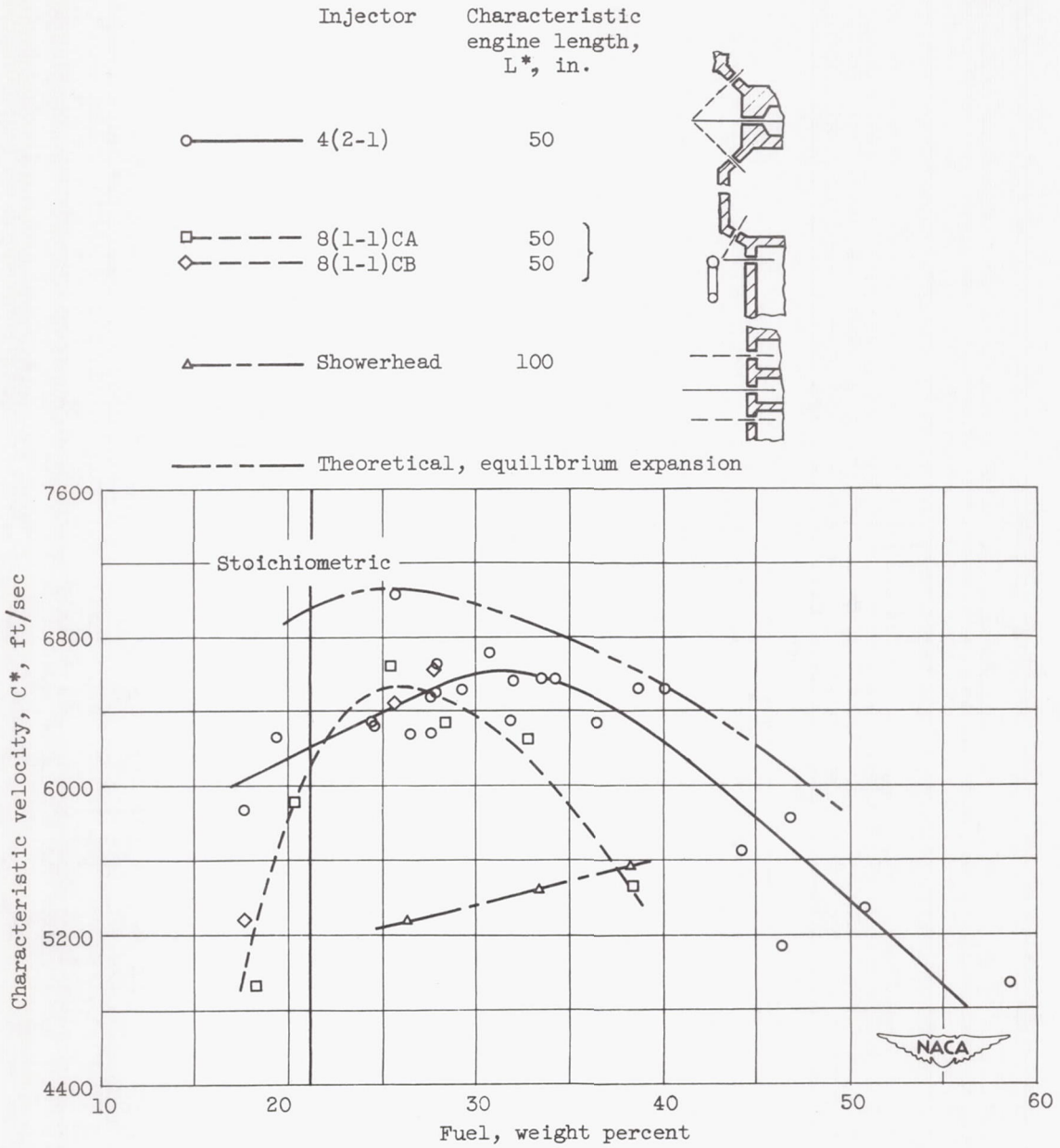

Figure 8. - Theoretical and experimental characteristic velocity of liquid fluorine - liquid ammonia in 100-pound-thrust rocket engines. Chamber pressure, 300 pounds per square inch absolute.

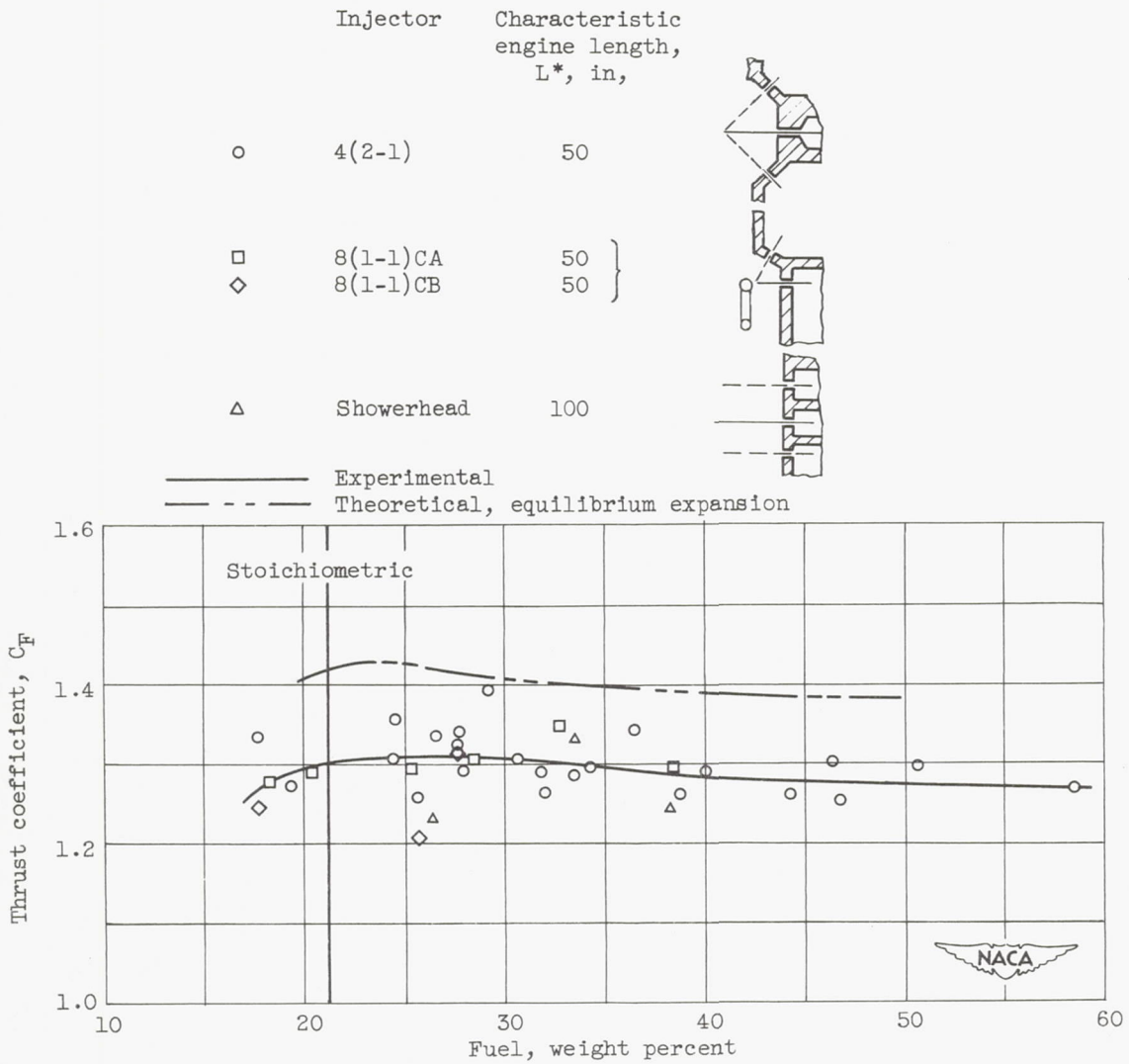

Figure 9. - Theoretical and experimental thrust coefficient of liquid fluorine - liquid ammonia in 100-pound-thrust rocket engines. Chamber pressure, 300 pounds per square inch absolute.

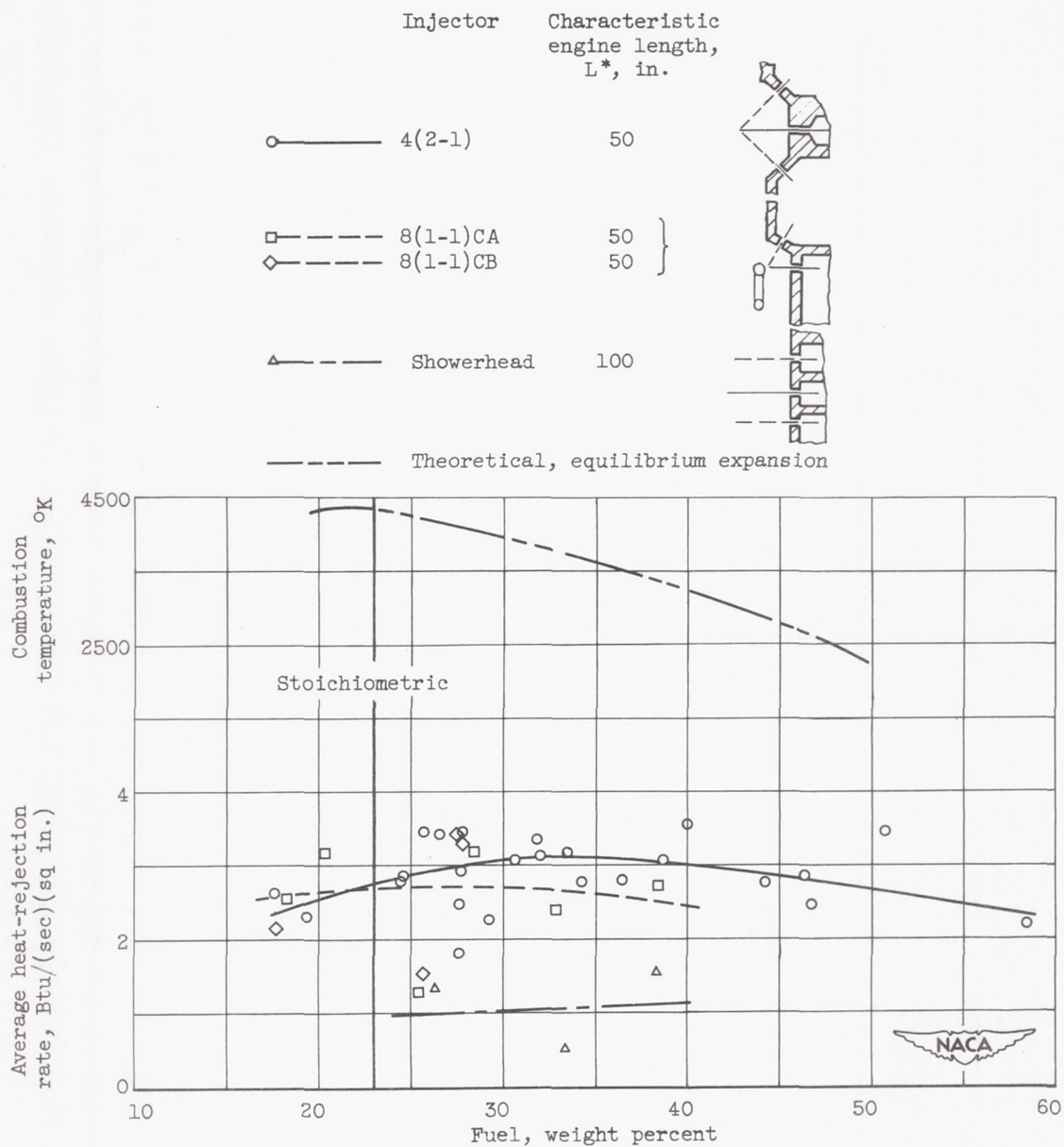

Figure 10. - Theoretical combustion temperature and averaged total experimental heat rejection to complete engine assembly of liquid fluorine - liquid ammonia in 100-pound-thrust rocket engines. Chamber pressure, 300 pounds per square inch absolute.

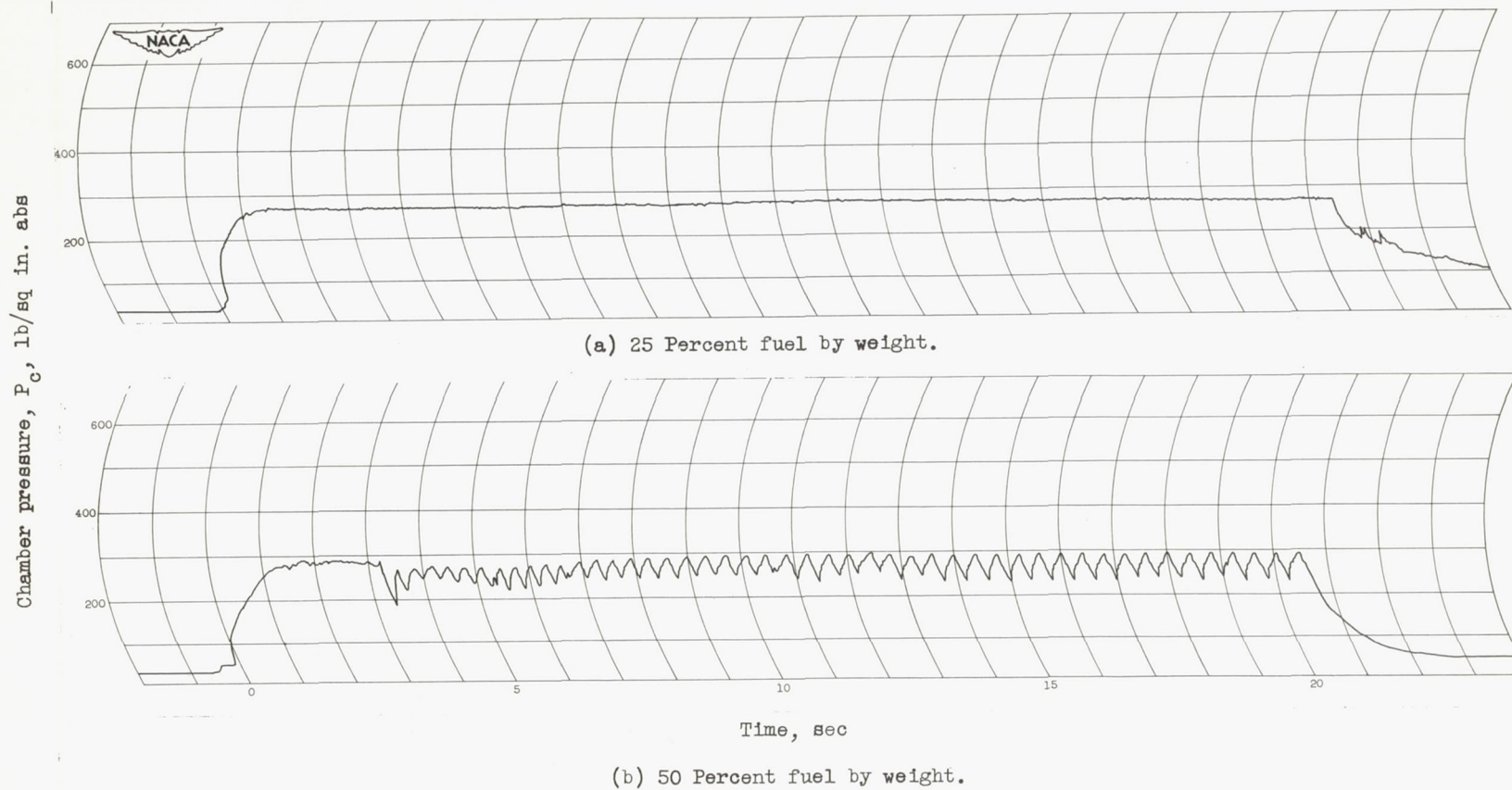
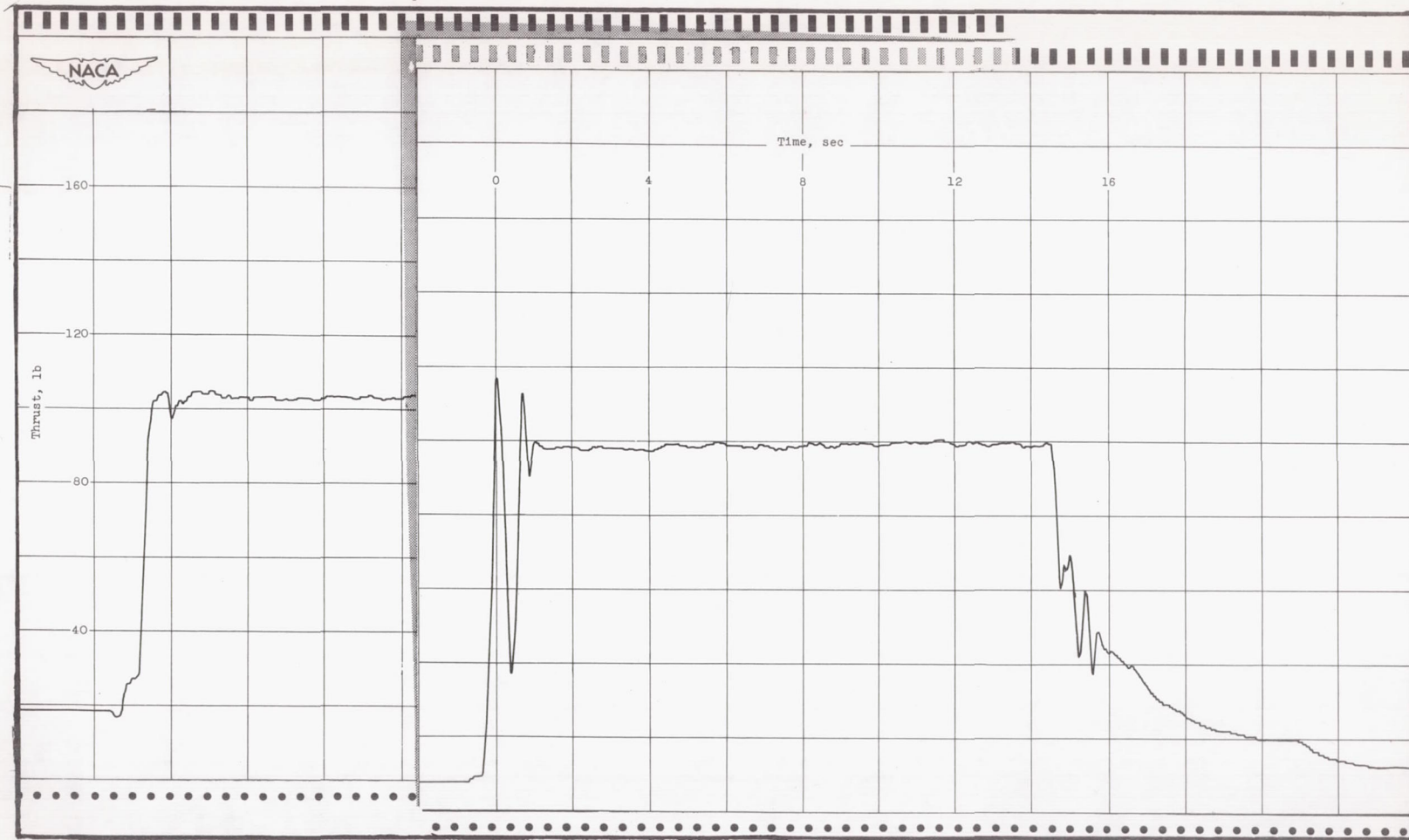

Figure 11. - Chamber-pressure records from runs with 4(2-1) injector at different propellant mixture ratios in 100-pound-thrust rocket engines at chamber pressure of 300 pounds per square inch absolute.



(a) Engine start with fuel lead.

(b) Engine start with oxidant lead.

Figure 12. - Developed engine-thrust records from runs in 100-pound-thrust rocket engines at chamber pressure of 300 pounds per square inch absolute.

