

RESEARCH MEMORANDUM

EXPERIMENTAL PERFORMANCE OF THE MIXED -OXIDES -OF -
NITROGEN - AMMONIA PROPELLANT COMBINATION
WITH SEVERAL INJECTION METHODS
IN A 1000 -POUND -THRUST
ROCKET ENGINE

By William A. Tomazic and George R. Kinney

Lewis Flight Propulsion Laboratory
Cleveland, Ohio

NATIONAL ADVISORY COMMITTEE
FOR AERONAUTICS
WASHINGTON

March 4, 1958
Declassified October 28, 1960

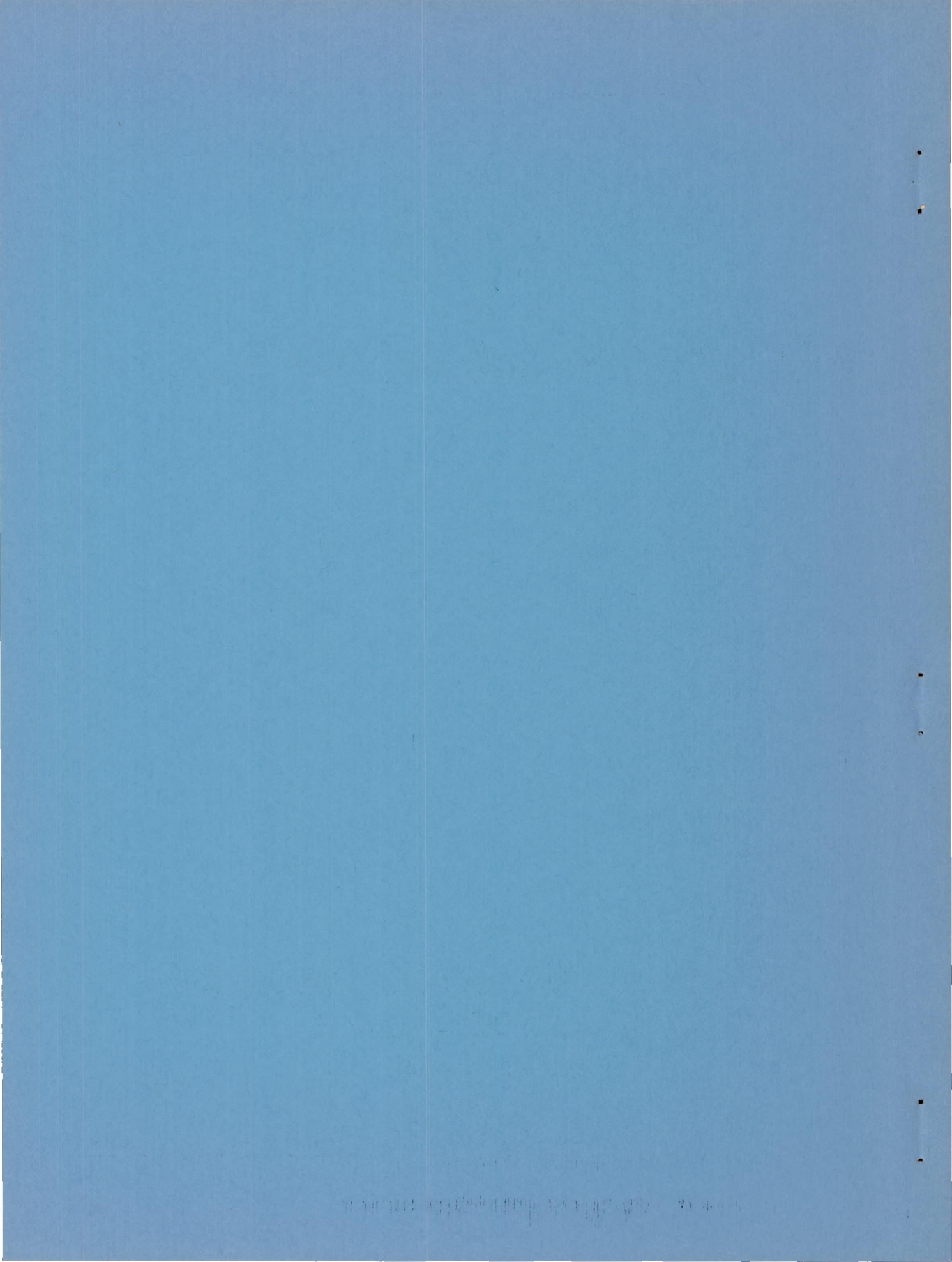

NATIONAL ADVISORY COMMITTEE FOR AERONAUTICS

RESEARCH MEMORANDUM

EXPERIMENTAL PERFORMANCE OF THE MIXED-OXIDES-OF-NITROGEN - AMMONIA
PROPELLANT COMBINATION WITH SEVERAL INJECTION METHODS
IN A 1000-POUND-THRUST ROCKET ENGINE

By William A. Tomazic and George R. Kinney

SUMMARY

The performance of the mixed-oxides-of-nitrogen (70 to 72 percent nitrogen tetroxide, 28 to 30 percent nitric oxide) - ammonia propellant combination was investigated over a range of conditions with several injectors. Data are presented for specific impulse, characteristic velocity, and thrust coefficient as functions of oxidant-fuel weight ratio.

The highest performance was obtained with a four-entry swirl-cup injector at 300 pounds per square inch absolute chamber pressure and 1100 pounds thrust. A maximum specific impulse of 236 pound-seconds per pound (99 percent of the peak theoretical value based on frozen composition expansion) was obtained at an oxidant-fuel ratio of 1.9. Characteristic velocity was 5430 feet per second or 99 percent of the theoretical maximum.

A triplet impinging jet injector also gave 99 percent of the peak theoretical characteristic velocity at 450 pounds per square inch absolute chamber pressure and 1.85 oxidant-fuel ratio. The peak specific impulse was 233 pound-seconds per pound or approximately 94 percent of the theoretical maximum based on frozen composition expansion.

Lower performance values were obtained with an injector in which the main flow of propellants was directed into a hot gas stream issuing from an antechamber in which approximately 10 percent of the flow was burned. An injector consisting of two concentric centrifugal spray nozzles (one fuel and one oxidant) also gave low performance.

INTRODUCTION

Experiments were conducted to determine the performance of the mixed-oxides-of-nitrogen (70 to 72 percent nitrogen tetroxide, 28 to 30 percent nitric oxide) - ammonia propellant combination over a range of conditions with several injectors. Previous experimental work with this combination has been limited.

Mixed oxides of nitrogen and ammonia are of interest as alternates to nitric acid and jet fuel in storable JATO and missile applications using pressurized propellant systems, since both are thermally stable, low in cost, and noncorrosive to ordinary materials of construction. In addition, the mixed-oxides-of-nitrogen - ammonia combination has a higher theoretical performance than nitric acid and jet fuel, and limited experimental work indicates that smooth combustion may be attained. Reference 1 includes an over-all evaluation of the mixed-oxides-of-nitrogen - ammonia combination in addition to theoretical and experimental performance figures. Rapid spontaneous ignition has been obtained over a wide temperature range using an alkali metal in the ammonia feed line (ref. 2).

Although run at constant thrust, the injectors used in this investigation were so designed as to be adaptable to variable thrust operation. That is, the injection orifices were designed to allow variation of their effective size or number through the addition of a relatively simple control.

The following injectors were tested:

- (1) A four-entry swirl cup at 300 pounds per square inch absolute chamber pressure and 1100 pounds thrust
- (2) A triplet impinging jet at 450 pounds per square inch absolute and 1600 pounds thrust
- (3) A hot-jet mixing injector at 400 pounds per square inch absolute and 1400 pounds thrust
- (4) A concentric swirl injector at 300 pounds per square inch absolute and 1000 pounds thrust
- (5) A two-entry swirl cup over a range of chamber pressures from 85 to 410 pounds per square inch absolute and thrusts from 200 to 480 pounds

Experimental values of specific impulse, characteristic velocity, and thrust coefficient for a range of oxidant-fuel weight ratios are presented for each injector and compared with the theoretical performance of reference 1.

APPARATUS

Propellants and Flow System

The oxidant was mixed oxides of nitrogen, which consisted of 70 to 72 percent nitrogen tetroxide and 28 to 30 percent nitric oxide. The fuel was liquid anhydrous ammonia. Both were obtained as liquids in commercial cylinders.

The propellants were fed to the engine from helium-pressurized tanks; the flow rates were controlled by tank pressure. Firing operations were accomplished by remotely controlled valves. A chamber was provided between the fuel-control valve and the engine to hold lithium, which was used to obtain spontaneous ignition as in reference 2. All components of both fuel and oxidant flow systems were of stainless steel.

Engine and Mounting

The engine was mounted on a movable stand supported on two steel flexure plates perpendicular to it. The stand was inclined downward at an angle of 30° .

The engine (fig. 1) consisted of an uncooled steel chamber 4 inches in diameter and 13 inches long, and an uncooled copper nozzle. Most of the runs were made using a nozzle designed for 1000 pounds thrust at a chamber pressure of 300 pounds per square inch absolute. One set of runs was made using a nozzle designed for 350 pounds thrust at a chamber pressure of 300 pounds per square inch absolute.

Injectors

Four-entry swirl cup. - The four-entry swirl cup (fig. 2) had two fuel and two oxidant entries arranged alternately about the cup 90° apart. The entry holes were tangent to the circumference of the cup and 10° from normal to the axis pointing out of the cup. The cup length was twice the cup diameter. Water-flow tests at rated flows showed a pressure drop of 100 pounds per square inch for the oxidant and 110 pounds per square inch for the fuel. However, during operation, equivalent flows gave pressure drops of 290 pounds per square inch for the oxidant and 310 pounds per square inch for the fuel, because the pressure in the swirl cup was probably considerably higher than the chamber pressure.

Triplet impinging jet injector. - Figure 3 shows the triplet impinging jet injector. It had 120 oxidant holes of 0.037-inch diameter and 60 fuel holes of 0.047-inch diameter. The injector face consisted of five 0.75-inch mild-steel tubes, three for oxidant and two for fuel with fuel and oxidant tubes alternating. Six groups of ten triplet sets each were arranged in two parallel rows across the injector face. Rated flows were obtained at a pressure drop of 100 pounds per square inch.

Hot-jet mixing injector. - The hot-jet mixing injector (fig. 4) consisted of an antechamber in which approximately 10 percent of the total flow was burned and a second chamber in which the remainder of the flow was introduced through drilled tubes into the hot jet issuing from the antechamber. The tubes could be rotated to produce different flow

patterns including: (1) model A - impingement of fuel and oxidant; (2) model B - both fuel and oxidant directed upstream with fuel splashing off the wall separating the antechamber and main chamber; and (3) model C - same as model A but with no hot jet. The injector was designed for 100-pounds-per-square-inch pressure drop through the primary injector and 75-pounds-per-square-inch drop through the main injector.

Concentric swirl injector. - The concentric swirl injector (fig. 5) was composed of two centrifugal spray nozzles mounted concentrically, with the spray from the inner nozzle impinging at the exit lip of the outer nozzle. The injector was run in three different ways: (1) model A - the fuel and the oxidant were swirled in opposite directions with the oxidant in the inner cup; (2) model B - the fuel and the oxidant were swirled in the same direction with the oxidant in the inner cup; and (3) model C - the fuel and the oxidant were swirled in the same direction with the fuel in the inner cup. Pressure drops were 100 pounds per square inch at rated flows.

Two-entry swirl cup. - The two-entry swirl cup (fig. 6) had one fuel and one oxidant entry opposite each other and tangent to the cup circumference. The entries were at 10° from normal to the axis of the cup. The cup inner diameter was 0.54 inch and the length was 1.08 inches.

Exhaust-Duct System

An exhaust-duct system was used for most of the runs to burn nitrogen dioxide fumes and incomplete combustion products. Two differently designed ducts were used to channel the exhaust gases from the rocket to the burner. The duct used for the majority of the runs (fig. 7) enclosed most of the engine, leaving approximately a 4-inch annular space about the engine proper. The second duct (fig. 8), used in an attempt to improve the effectiveness of the burner in disposing of fumes, was constricted to approximately a 0.12-inch annulus about the nozzle.

Instrumentation

Thrust. - Thrust was measured with a calibrated strain gage and recorded on a self-balancing potentiometer. The precision of the measurements, including variation of calibration constants and interpretation of chart readings, was approximately ± 2 percent.

Flow rates. - Turbine-type flowmeters were used for the four-entry swirl-cup tests, and the precision of flow measurements made with them, including density determinations, was approximately ± 1.5 percent. Flow measurements were made for the other tests by continuous tank weighing, using calibrated strain gages recording on self-balancing potentiometers. The precision of these measurements was approximately ± 2.5 percent.

Pressures. - Combustion-chamber pressure was measured both by Bourdon tube-type recorders and by variable-resistance-type pressure pickups whose output was recorded on an oscillograph. The precision of each method was approximately ± 1.0 percent. Mercury manometers were photographed to obtain duct pressures to approximately ± 1 inch of mercury. Fluctuations prevented more accurate measurement.

Temperature. - Copper-constantan thermocouples were used to measure propellant temperatures in the flow lines near the turbine-type flowmeters within $\pm 2^{\circ}$ F. Determination of propellant densities was within ± 0.5 percent.

PROCEDURE

Both fuel and oxidant were loaded into the cell tanks as liquids from commercial cylinders. Dry, high-pressure helium gas was used to force the propellants from the tanks to the engine. The addition of lithium to ammonia in the flow line made it self-igniting with mixed oxides of nitrogen. Valve openings were timed for an oxidant lead of approximately 0.1 second on start and a comparable override on shutdown. Upon shutdown, the injector and chamber were purged with helium gas. All run durations were limited to approximately 6 seconds because uncooled engines were used.

Experimental specific impulse was calculated from measured values of thrust and propellant flows. The precision of the calculated values was approximately ± 3.5 percent for the turbine-type flowmeters and ± 4.5 percent for the weight method. Characteristic velocity was calculated from measured chamber pressure, throat area, and propellant flows. The precision was approximately ± 3.0 percent with the turbine-type flowmeters and ± 4.0 percent with the weight method. Thrust coefficient was obtained from experimental chamber pressure, thrust, and throat area to a precision of approximately ± 3.5 percent. Values of specific impulse and thrust coefficient for the triplet impinging jet, hot-jet mixing, and concentric swirl injectors were corrected for operation with the exhaust ducts as shown in the appendix.

RESULTS

Experimental results are presented in table I and figures 9 to 14.

Four-entry swirl cup. - The experimental data for the four-entry swirl cup are given in figure 9. Figure 9(a) shows data as measured and figure 9(b) shows the data when corrected for exhaust-duct effects. The peak characteristic velocity obtained was 5430 feet per second or 99 percent of the theoretical maximum as given by reference 1. Specific

impulse reached a value of 236 pound-seconds per pound at an oxidant-fuel ratio of 1.9. This is 99 percent of the theoretical maximum based on frozen composition expansion and 97 percent of the maximum based on equilibrium expansion. The thrust coefficient of 1.40 was approximately equal to that predicted by theory for the expansion ratio used assuming frozen composition. No problems with oscillatory combustion or excessive heat transfer were encountered.

Triplet impinging jet injector. - Figure 10 gives experimental data for the triplet impinging jet. A characteristic velocity of 5420 feet per second or 99 percent of the theoretical maximum was obtained at an oxidant-fuel ratio of 1.85. Specific impulse was 233 pound-seconds per pound or 94 percent of the theoretical maximum for frozen composition expansion. Combustion was smooth and no burn-outs occurred.

Hot-jet injector. - The experimental performance for the hot-jet injector (models A, B, and C) is shown in figure 11. A single curve was faired through the data because the performance for the different models was approximately the same. Characteristic velocity reached a peak of 4870 feet per second at a mixture ratio of 1.70, which is 89 percent of the theoretical maximum. Specific impulse was 200 pound-seconds per pound or 82 percent of the peak for frozen composition expansion. Combustion was audibly rough during runs with model B.

Concentric swirl injector. - Figure 12 shows performance data for the three models of the concentric swirl injector. The peak characteristic velocity was 3875 feet per second, which is 71 percent of the maximum theoretical value. The highest specific impulse was 165 pound-seconds per pound or 69 percent of the maximum for frozen composition expansion. The highest performance was obtained at an oxidant-fuel ratio of 1.75. Some of the runs with this injector produced audibly rough combustion.

Two-entry swirl cup. - Figure 13 shows the experimental characteristic velocity for the two-entry swirl cup at two different pressure levels. At the higher pressure level (350 to 410 lb/sq in. abs), approximately 100 percent of the theoretical value was obtained. Approximately 87 percent of the theoretical peak was obtained at the low pressure level (85 to 155 lb/sq in. abs).

DISCUSSION

Injector comparison. - A comparison of the injectors based on characteristic velocity is shown in figure 14.

The four-entry swirl cup gave the highest performance over the widest range of mixture ratio. Performance was dependent on cup and propellant entry geometry. A properly designed swirl cup forces intimate

contact of the two propellants in their liquid state in a relatively confined space, which gives a high degree of mixing rapidly (ref. 3). In addition, initial reactions in the swirl cup are important with self-igniting propellants. A large part of the liquid-phase reaction and heat release preceding actual ignition and combustion can take place in the cup. It has been shown (refs. 4 and 5) that, as propellant residence time in the cup is increased from a low value, the performance increases to a maximum, after which hard starts and explosions occur. The optimum cup stay-time is evidently just short of the propellant ignition lag. The ratio of cup volume to the propellant flows is also important, since too much volume may prevent optimum mixing and too little may tend to quench the propellant reaction.

Peak performance comparable to that obtained with the four-entry swirl cup was obtained with the triplet impinging jet. However, an increased sensitivity to mixture ratio is evident because the curve drops off more quickly in both directions from the peak. Relative propellant stream momentums change rapidly with changes in mixture ratio, and thus mixing, atomization, and distribution are affected. The triplet configuration used is an unusual one, because of considerations of application to variable thrust operation. This configuration (fig. 3) induced a great deal of circulation against the injector, which led to a distinct erosion pattern after some 10 to 15 runs. This indicates a violent scrubbing action by the hot gases circulating back against the tubes. Some erosion of the aluminum injector body occurred, but not enough to prevent continued operation.

The hot-jet injector was designed with the intention of promoting propellant mixing and atomization by injecting them into a relatively low-velocity hot gas stream generated in a precombustion chamber at a pressure only 25 pounds per square inch above that in the main chamber. Other injectors of this type with higher-velocity hot gas streams and much larger pressure drops from the primary chamber to the main chamber (refs. 6 to 8) have been relatively successful. A low-velocity hot jet was used to avoid a prohibitively high over-all pressure drop. Tests of the same injector with and without the hot jet showed no appreciable difference in performance, which was relatively low in all cases. Apparently the velocity of the hot jet was too low to aid propellant mixing and atomization.

The concentric swirl injector (fig. 5) gave only about 70 percent of the theoretical maximum performance. This type of injection permits very simple construction, particularly for variable-thrust operation where simple gate valves at each of two propellant entries would control flows. Model A was designed to utilize the difference in relative velocities of the two streams swirling in opposite directions to obtain good mixing. Water-spray tests showed that each spray nozzle individually gave a good hollow-cone spray, but the resultant of the two was a heavy

slow-moving shower of relatively large drops. No conclusion could be made as to mixing. Water tests with models B and C gave the same results as model A. Performance for all three models was about the same, as shown by figure 12. Performance by this method might be improved with a change in arrangement; for example, impinging the two sprays in open space instead of on a surface.

In summary, the performance of the four-entry swirl cup indicated that it is a most promising injector for development into a variable-thrust rocket engine, using the propellants under consideration.

Materials. - All the injectors used were constructed of relatively noncritical materials, mild steel and aluminum. Only the triplet impinging jet gave any erosion problems, but these did not affect operation until after about 12 runs. Neither corrosion nor heat transfer appears to offer much difficulty.

Engine starting. - The two-stage pressure rise during ignition previously shown to exist with this propellant combination (ref. 9) was noted to be a possible source of trouble. A few runs were made during which the high-pressure stage was not reached, the combustion proceeding at a very low pressure in spite of full propellant flows to the chamber. One run during which the low-pressure condition was allowed to persist for approximately 3 seconds resulted in an explosion. The fact that virtually all starts were accomplished without difficulty suggests that this trouble can be overcome.

Applicability of injector design to flow control. - Control of orifice area could be achieved through the use of a single piston with the four-entry swirl cup, a sliding-piston cam or a rotating-barrel cam for each tube of the impinging jet or hot-jet injector, and a gate valve at each entry of the concentric swirl. The two-entry swirl cup could be controlled with a piston or two gate valves. It would appear that a swirl-cup-type injector offers the best possibilities for simple control.

SUMMARY OF RESULTS

The performance of mixed oxides of nitrogen and ammonia was obtained for a range of conditions with several injectors. Peak performance results are summarized as follows:

Injector	Nominal thrust, lb	Chamber pressure, lb/sq in. abs	Oxidant-fuel ratio	Characteristic velocity, ft/sec	Percent of theoretical characteristic velocity	Specific impulse, (lb)(sec)/lb	Percent of theoretical specific impulse (frozen)
Four-entry swirl cup	1100	300	1.90	5430	99	236	99
Triplet impinging jet	1600	450	1.85	5420	99	233	94
Hot-jet mixing injector	1400	400	1.70	4870	89	200	82
Concentric swirl injector	1000	300	1.75	3875	71	165	69
Two-entry swirl cup	375	85-155 ^a 350-410	---- ----	~ 4750 ~ 5470	~ 87 ~ 100	--- ---	-- --

^a Operated with same chamber as others but with smaller throat exhaust nozzle.

Lewis Flight Propulsion Laboratory
National Advisory Committee for Aeronautics
Cleveland, Ohio, January 17, 1955

APPENDIX - EFFECT OF EXHAUST DUCTS ON ROCKET THRUST

The use of exhaust ducts to channel the rocket exhaust into a burner resulted in net or recorded thrusts lower than the engine would have developed without the ducts. The rocket operating with the ducts acted as a jet pump or ejector and induced atmospheric air into the ducts. The flow of air past the engine and its mountings and the reduction below atmospheric of the pressure acting on the base of the rocket nozzle both resulted in forces opposite to the engine thrust. Experiments were made to determine the magnitude of these forces with each duct used.

Three series of runs were made at a chamber pressure of 300 pounds per square inch absolute using the four-entry swirl cup: (1) firing with no exhaust duct, (2) using the constricted-entrance duct (fig. 8), and (3) using the open-entrance duct (fig. 7). Static-pressure taps were installed in both ducts as shown in figures 7 and 8. Free body diagrams for the three arrangements are shown in figure 15. The net axial thrust is equal to the reaction thrust of the engine plus the resultant of external pressure forces acting on the engine and its mountings. The resultant of external pressure forces is zero when no duct is used and the net thrust is equal to the reaction thrust of the engine.

When the engine was operated with a constricted-entrance duct, pressure at the rocket nozzle base was lowered because of the ejector action of the rocket exhaust (fig. 15(b)). This resulted in an unbalanced pressure force opposite in direction to the engine thrust and equal to the difference between the base and atmospheric pressures multiplied by the base area. Specific impulse and thrust coefficient for this condition are given in figure 9(a). Figure 9(b) shows the specific impulse and thrust coefficient corrected for the unbalanced pressure force, which averaged approximately 23 pounds for the runs made in the constricted-entrance duct.

When operating with an open-entrance duct, the system of pressure forces is more complicated (fig. 15(c)). The engine and its mounting were largely submerged in the duct, and a high-velocity air flow (approximately 360 ft/sec) passed over them, resulting from the ejector action of the rocket exhaust. Figure 7 shows the lowered pressures and the areas on which they acted. Average values of pressure differences for the surfaces acted on and the corresponding pressure forces are given in the following table:

80512

Area acted on by pressure (see fig. 7), sq in.	Atmospheric pressure minus pressure acting on area, lb/sq in. abs	Pressure force acting on area, lb
49.50	0.196	9.7
33.45	1.96	65.7
9.60	1.87	17.9
3.51	2.11	7.4
3.75	-1.47 (In same direction as engine thrust)	-5.5

The average total-pressure force opposite to the engine thrust is 95.2 pounds. Figure 9(a) shows specific impulse and thrust coefficient uncorrected for this pressure force. The corrected values of specific impulse and thrust coefficient are given in figure 9(b). As would be expected, characteristic velocity was unaffected by the different exhaust conditions.

Similar corrections were made to the data obtained with the triplet impinging jet, the hot-jet injector, and the concentric swirl injector. The corrections used were average values for either the constricted- or open-entrance ducts as determined using the four-entry swirl-cup injector. Since ejector action would tend to be greater at the higher chamber pressures than at 300 pounds per square inch absolute (for the conditions of these tests), these corrections are probably slightly low for the hot-jet and triplet injectors, which were run at chamber pressures of 400 and 450 pounds per square inch absolute, respectively.

REFERENCES

1. Brown, P.: Design Study for 15 Sec, 1000 Lb and 5 Sec, 4500 Lb Expendable Liquid Propellant JATO Rockets. Final Summary Rep. SPD 359, Spec. Proj. Dept., The M. W. Kellogg Co. (N.J.), Mar. 31, 1953. (Dept. Navy, Bur. Ord. Contract No. NOas-52-830-c.)
2. Kinney, George R., Humphrey, Jack C., and Hennings, Glen: Rocket Engine Starting with Mixed Oxides of Nitrogen and Liquid Ammonia by Flow-Line Additives. NACA RM E53F05, 1953.
3. Hartridge, H., and Roughton, F. J. W.: A Method of Measuring the Velocity of Very Rapid Chemical Reactions. Proc. Roy. Soc. (London), ser. A., vol. CIV, no. A726, Oct. 1, 1923, p. 379.

4. Fredrickson, H., and Rice, P. J.: Second Progress Report on Rocket Motor Throttling. UMM-89, Eng. Res. Inst., Willow Run Res. Center, Univ. Mich., Jan. 1952. (USAF Contract W33-038-ac-14222, Proj. MX-794.)
5. Bolt, J. A., et al.: Third Progress Report on Rocket Motor Throttling. UMM-109, Eng. Res. Inst., Willow Run Res. Center, Univ. Mich., May 1953. (USAF Contract W33-038-ac-14222, Proj. 794.)
6. Ferris, D. F., Bell, H. S., Frick, R. G., and Leak, A. B.: Design of Two Liquid Propellant Expendable JATO Powerplants. Final Rep. No. RMI-476-F, Reaction Motors, Inc. (N.J.), Apr. 30, 1953. (Contract NOas 52-1013-c, RMI Proj. 476.)
7. Banerian, G., et al.: Acid-Gasoline ATO Power Plant Development. Prog. Rep. No. 1002/22-24, Feb. 1-Mar. 1, 1953, Aerojet-General Corp. (Calif.), May 21, 1953. (Contract AF 33(038)-2733, Proj. MX-1079, E.O. No. 539-44.)
8. Noeggerath, W. C.: Design Study of the LAR, a 5.0-Inch Liquid-Propellant Air-to-Air Rocket of High Thrust and Short Burning Time. Navord Rep. 1939, NOTS 482, U. S. Naval Ord. Test Station, China Lake (Calif.), Dec. 18, 1951.
9. Hennings, Glen, Ladanyi, Dezso J., and Enders, John H.: Ignition of Ammonia and Mixed Oxides of Nitrogen in 200-Pound-Thrust Rocket Engines at 160° F. NACA RM E54C19, 1954.

TABLE I. - SUMMARY OF PERFORMANCE OF MIXED OXIDES OF NITROGEN AND LIQUID AMMONIA

[Characteristic length, 65 in.]

Oxidant-fuel weight ratio	Total propellant flow, lb/sec	Recorded thrust, lb	Chamber pressure, lb/sq in. abs	Specific impulse, (lb)(sec)/lb	Characteristic velocity, ft/sec	Thrust coefficient	Thrust correction due to duct, lb	Corrected thrust, lb	Corrected specific impulse, (lb)(sec)/lb	Corrected thrust coefficient
Four-entry swirl cup; no duct										
1.88	4.70	1122	298	239	5470	1.41	--	----	---	----
2.16	4.81	1122	300	234	5370	1.40	--	----	---	----
1.79	4.94	1151	310	233	5410	1.39	--	----	---	----
1.71	4.97	1167	310	235	5370	1.40	--	----	---	----
1.77	4.91	1154	309	235	5420	1.40	--	----	---	----
2.20	5.03	1167	313	232	5360	1.40	--	----	---	----
2.23	5.00	1142	312	228	5340	1.38	--	----	---	----
Four-entry swirl cup; constricted-entrance duct										
2.28	4.86	1114	302	229	5310	1.39	23	1137	234	1.42
----	----	1126	307	---	----	1.38	23	1149	---	1.41
1.71	4.74	1098	300	232	5420	1.38	22	1120	236	1.40
1.70	4.59	1071	296	233	5530	1.36	22	1093	238	1.39
1.97	4.64	1073	294	231	5425	1.37	24	1097	236	1.40
1.84	4.61	1087	297	231	5400	1.38	24	1111	236	1.40
1.98	4.85	1120	308	231	5430	1.37	24	1144	236	1.40
Four-entry swirl cup; open-entrance duct										
2.08	4.81	1027	301	214	5360	1.28	92	1119	233	1.40
1.66	5.03	1055	---	210	----	----	93	1148	228	----
1.89	4.88	1085	318	222	5580	1.28	87	1174	240	1.39
1.69	4.90	1042	306	213	5340	1.28	75	1117	228	1.37
2.39	5.02	1032	306	206	5210	1.27	99	1131	225	1.39
Triplet impinging jet; open-entrance duct										
1.84	6.94	1505	434	217	5440	1.28	95	1600	230	1.36
2.71	8.80	1695	484	192	4780	1.30	95	1790	204	1.37
1.91	7.62	1660	472	218	5390	1.30	95	1755	230	1.37
2.38	8.37	1660	476	198	4980	1.28	95	1755	210	1.35
1.64	7.13	1645	---	231	----	----	95	1740	244	----
1.32	7.56	1487	381	197	4880	1.29	95	1582	211	1.37
1.58	7.37	1520	434	206	5070	1.31	95	1615	219	1.39
2.24	7.46	1580	466	212	5425	1.26	95	1675	224	1.34
2.24	7.59	1615	465	213	5325	1.29	95	1710	225	1.37
1.84	6.96	1585	460	228	5750	1.28	95	1680	241	1.36
2.02	7.51	1620	459	216	5320	1.31	95	1715	228	1.39

TABLE I. - Concluded. SUMMARY OF PERFORMANCE OF MIXED OXIDES OF NITROGEN AND LIQUID AMMONIA

[Characteristic length, 65 in.]

Model (see figs 4 and 5)	Oxidant- fuel weight ratio	Total propel- lant flow, lb/sec	Recorded thrust, lb	Chamber pressure, lb/sq in. abs	Specific impulse, (lb)(sec) lb	Charac- teristic velocity, ft/sec	Thrust coeffi- cient	Thrust correction due to duct, lb	Corrected thrust, lb	Corrected specific impulse, (lb)(sec) lb	Corrected thrust coefficient
Hot-jet mixing injector; constricted-entrance duct											
A ↓	2.20	8.48	1520	424	179	4310	1.34	22	1542	182	1.36
	1.70	7.56	1480	412	196	4700	1.34	22	1502	199	1.36
	2.20	8.70	1465	422	168	4180	1.30	22	1487	171	1.32
	1.43	7.38	1428	406	194	4750	1.32	22	1450	196	1.34
B ↓	1.38	7.48	1255	367	168	4250	1.27	22	1277	171	1.29
	1.36	7.09	1282	372	181	4540	1.28	22	1304	184	1.30
	1.65	7.40	1234	362	167	4240	1.27	22	1256	170	1.29
	1.63	6.95	1302	377	187	4700	1.28	22	1324	190	1.30
C ↓	1.67	7.55	1396	397	185	4500	1.32	22	1418	188	1.34
	1.44	7.81	1363	389	174	4270	1.31	22	1385	177	1.34
	1.72	6.93	1430	407	206	5030	1.31	22	1452	209	1.34
	1.56	7.23	1470	416	203	4930	1.32	22	1492	206	1.35
Concentric swirl; open-entrance duct											
A ↓	1.65	7.16	850	270	119	3260	1.16	95	945	132	1.29
	1.68	6.83	965	281	141	3580	1.27	95	1060	155	1.39
	1.72	7.47	1060	309	142	3600	1.27	95	1155	155	1.38
B ↓	1.40	7.43	970	---	130	----	----	95	1065	143	----
	1.53	7.17	1040	---	145	----	----	95	1135	158	----
	1.99	5.83	1000	---	171	----	----	95	1095	188	----
Concentric swirl; constricted-entrance duct											
C ↓	2.86	8.57	993	276	116	2830	1.32	22	1015	118	1.35
	2.24	8.30	1040	286	125	3030	1.33	22	1062	128	1.36
	1.76	6.25	1020	284	163	4000	1.32	22	1042	167	1.35
Two-entry swirl cup; open-entrance duct											
	3.49	1.78		87		4290		--	----	---	----
	----	----		100		----		---	----	---	----
	1.61	2.19		114		4560		---	----	---	----
	1.66	2.02		114		4940		---	----	---	----
	2.38	2.47		136		4810		---	----	---	----
	1.98	2.74		145		4620		--	----	---	----
	1.88	2.21		120		4760		---	----	---	----
	1.92	2.48		135		4770		---	----	---	----
	2.12	2.95		155		4595		---	----	---	----
Smaller nozzle used with same chamber as above; characteristic length, 195 in.											
	1.92	1.85		379		5600		--	----	---	----
	2.14	1.81		349		5270		---	----	---	----
	2.37	2.09		408		5340		---	----	---	----
	2.32	2.00		395		5390		---	----	---	----

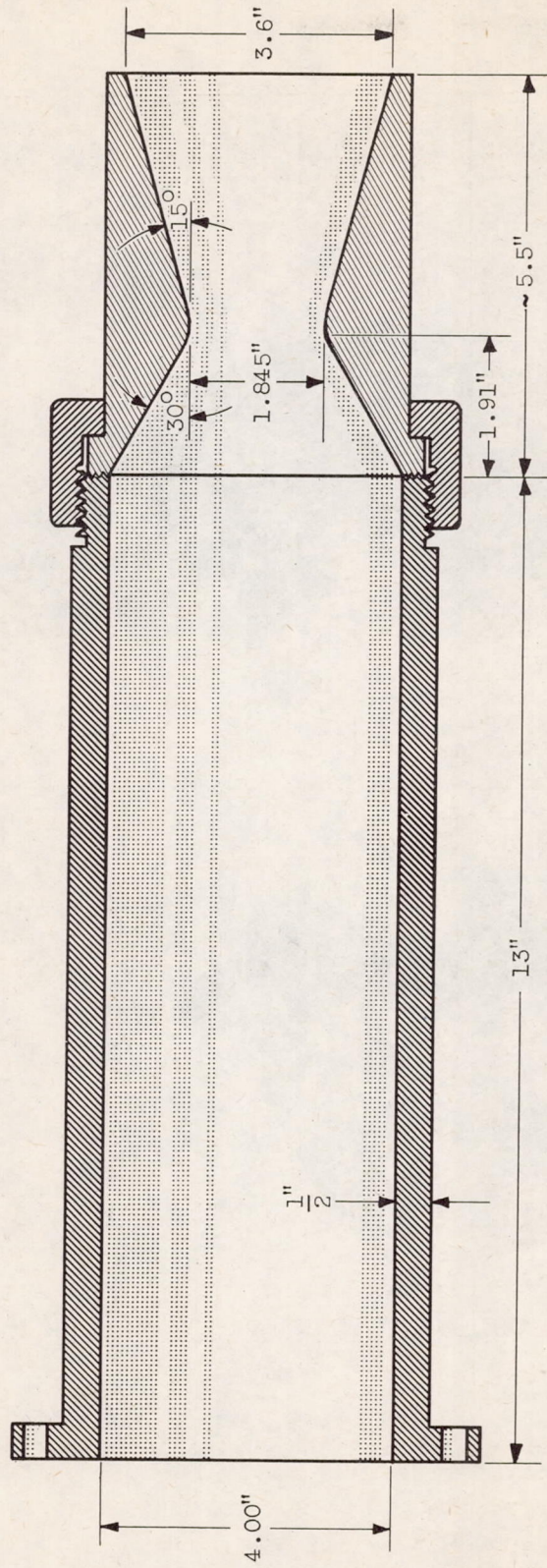

CD-4174

Figure 1. - Thrust chamber assembly.

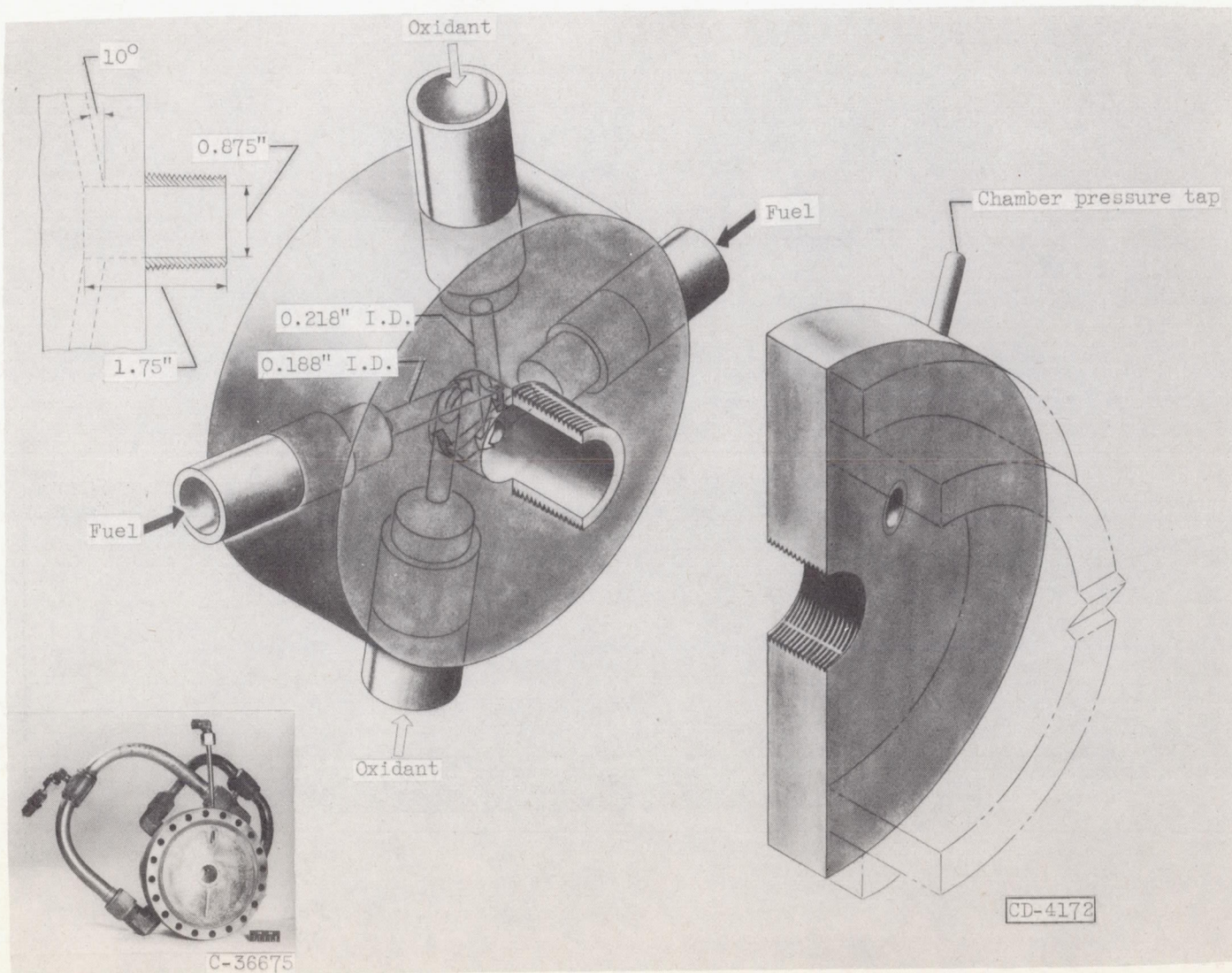

Figure 2. - Four-entry swirl-cup injector.

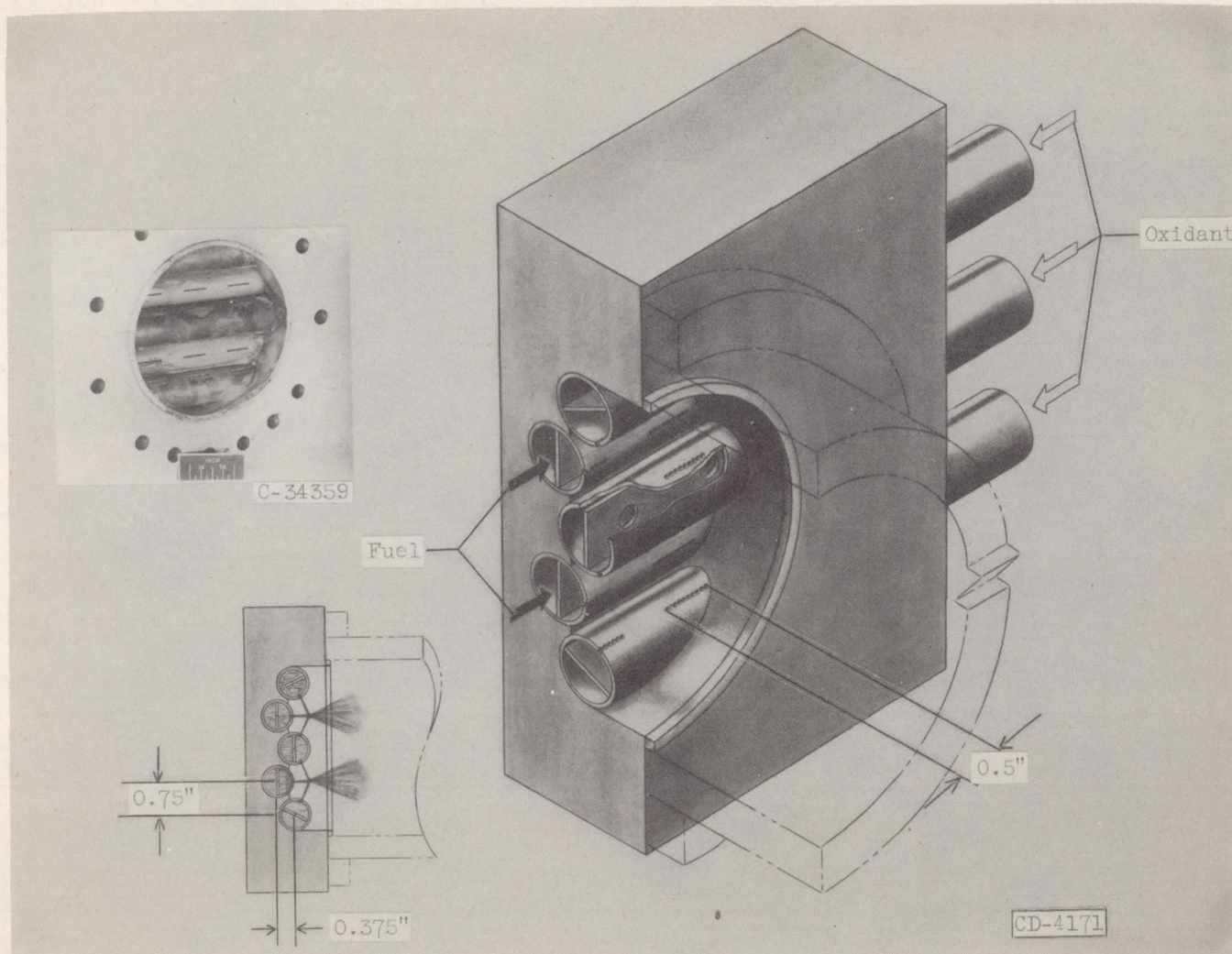

Figure 3. - Triplet impinging jet injector.

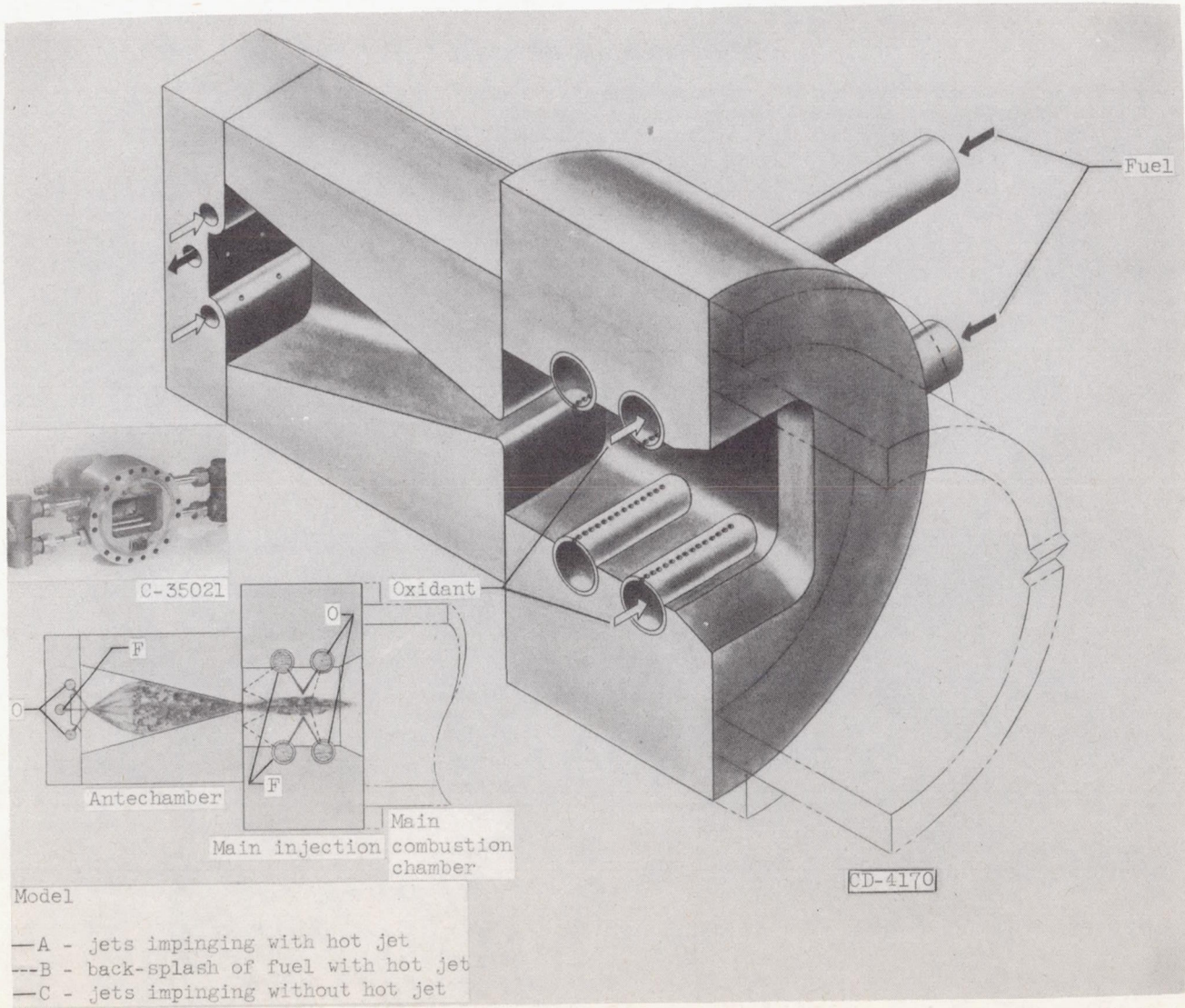

Figure 4. - Hot-jet mixing injector.

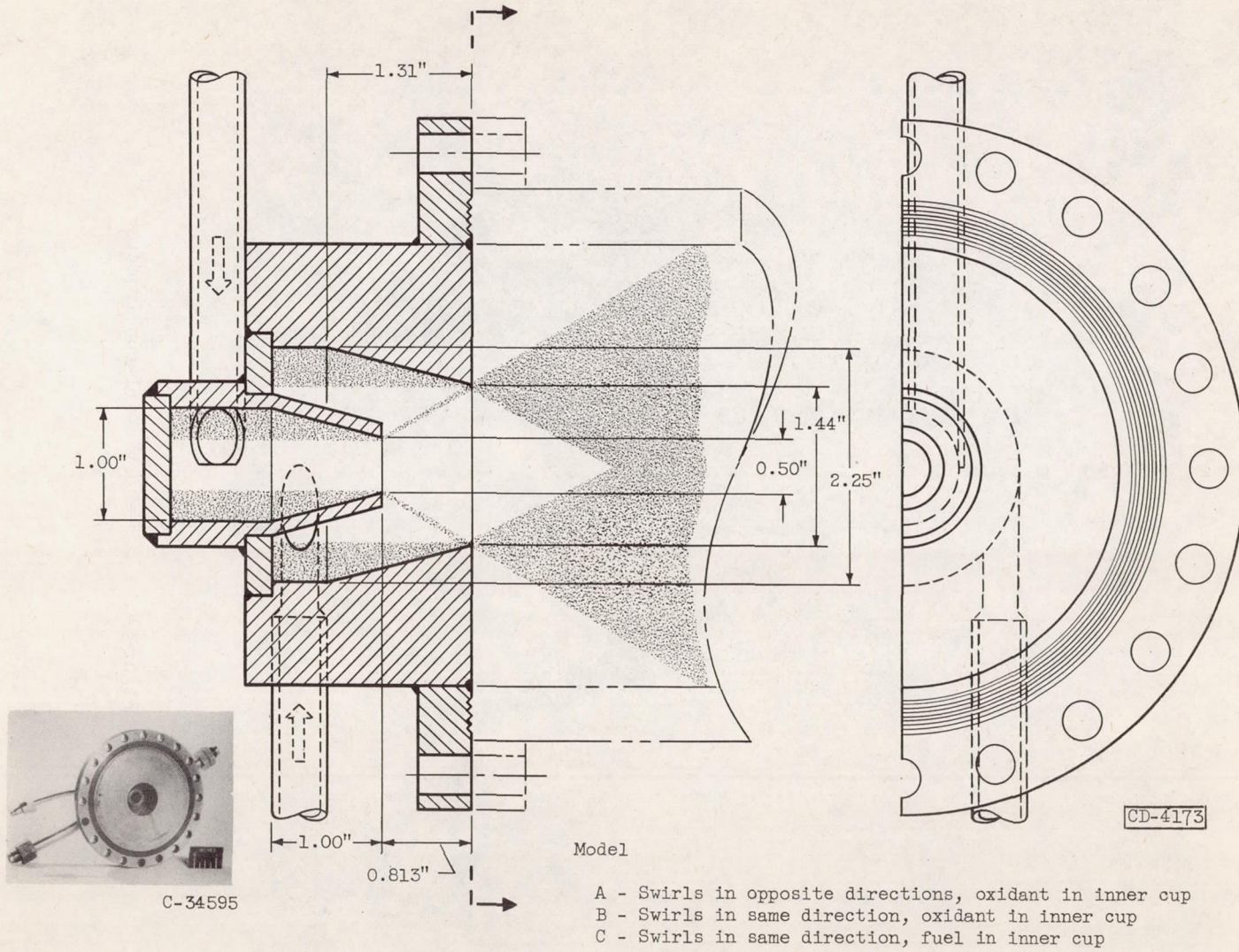

Figure 5. - Concentric swirl injector.

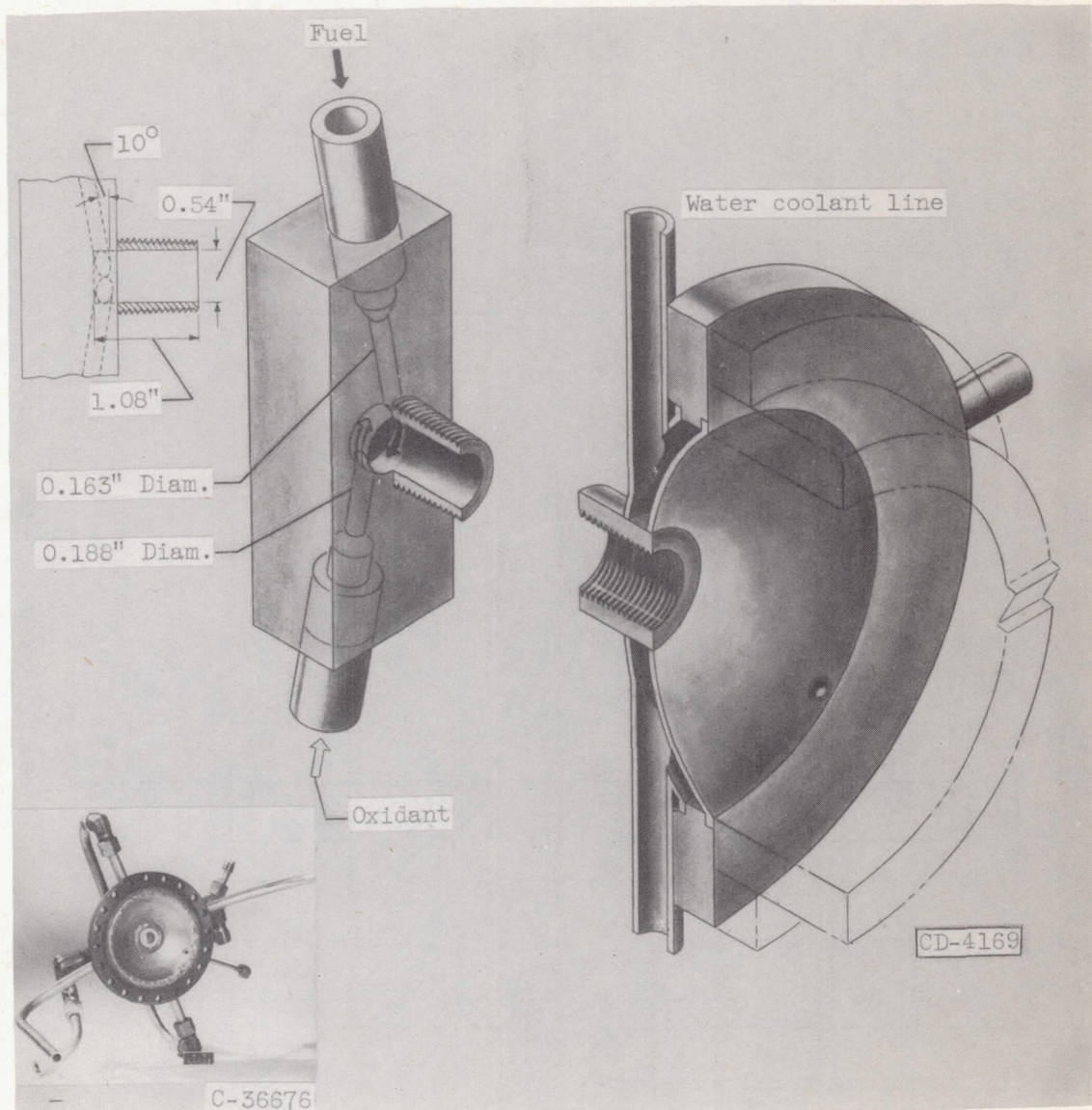

Figure 6. - Two-entry swirl-cup injector.

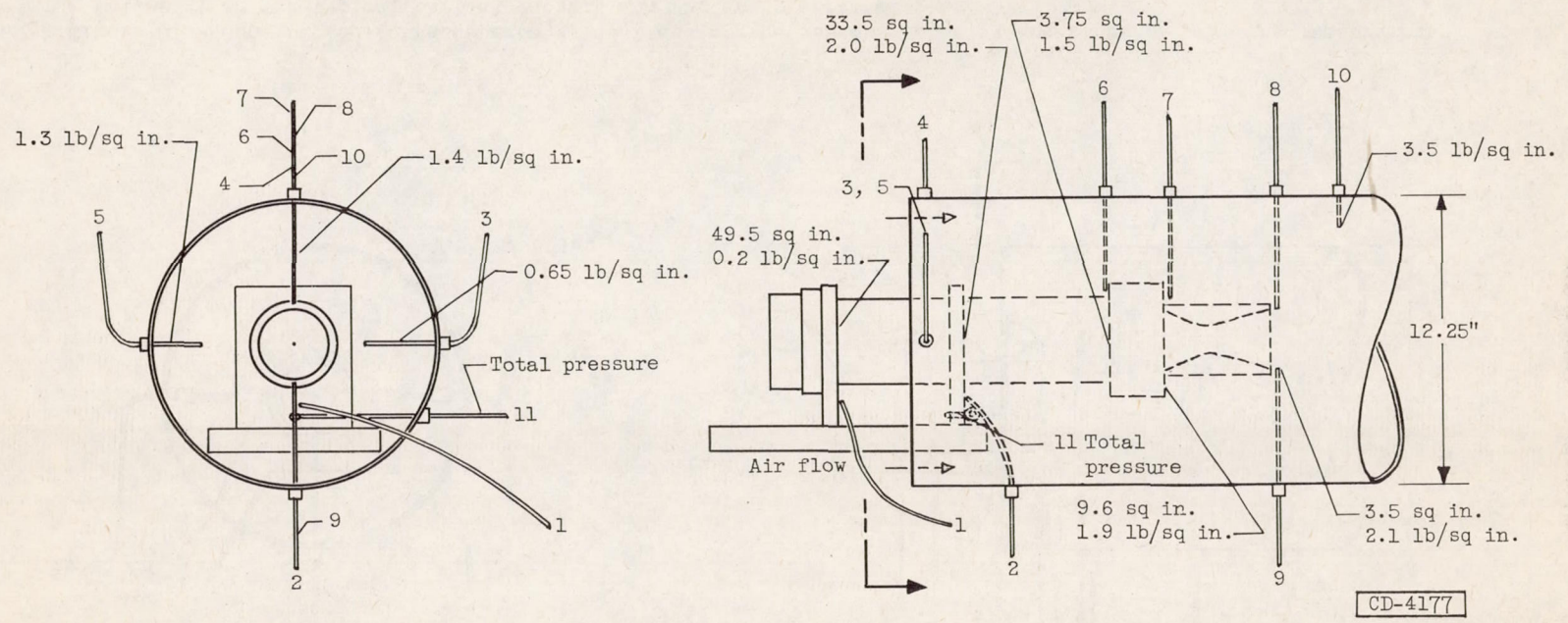

Figure 7. - Open-entrance exhaust duct and engine assembly showing locations of pressure measurements. Values given for typical partial vacuums and for areas affected.

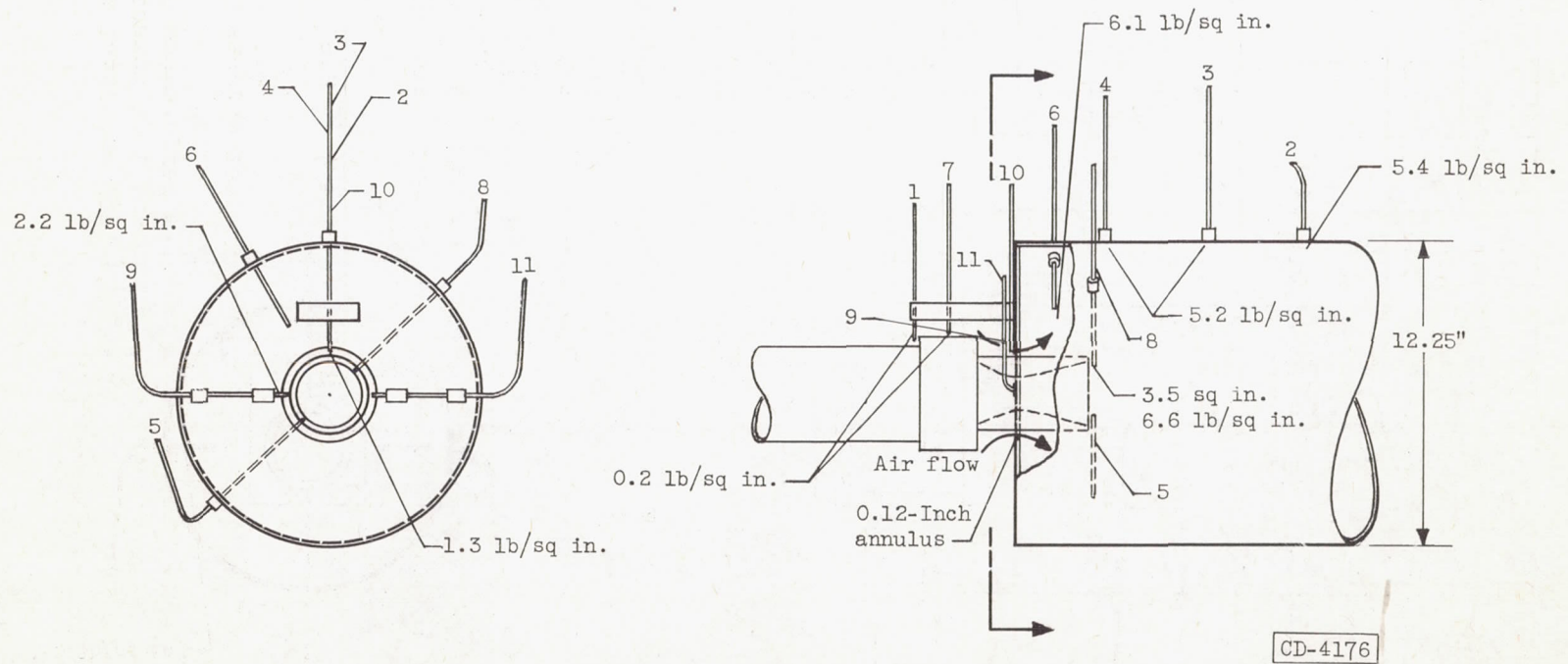
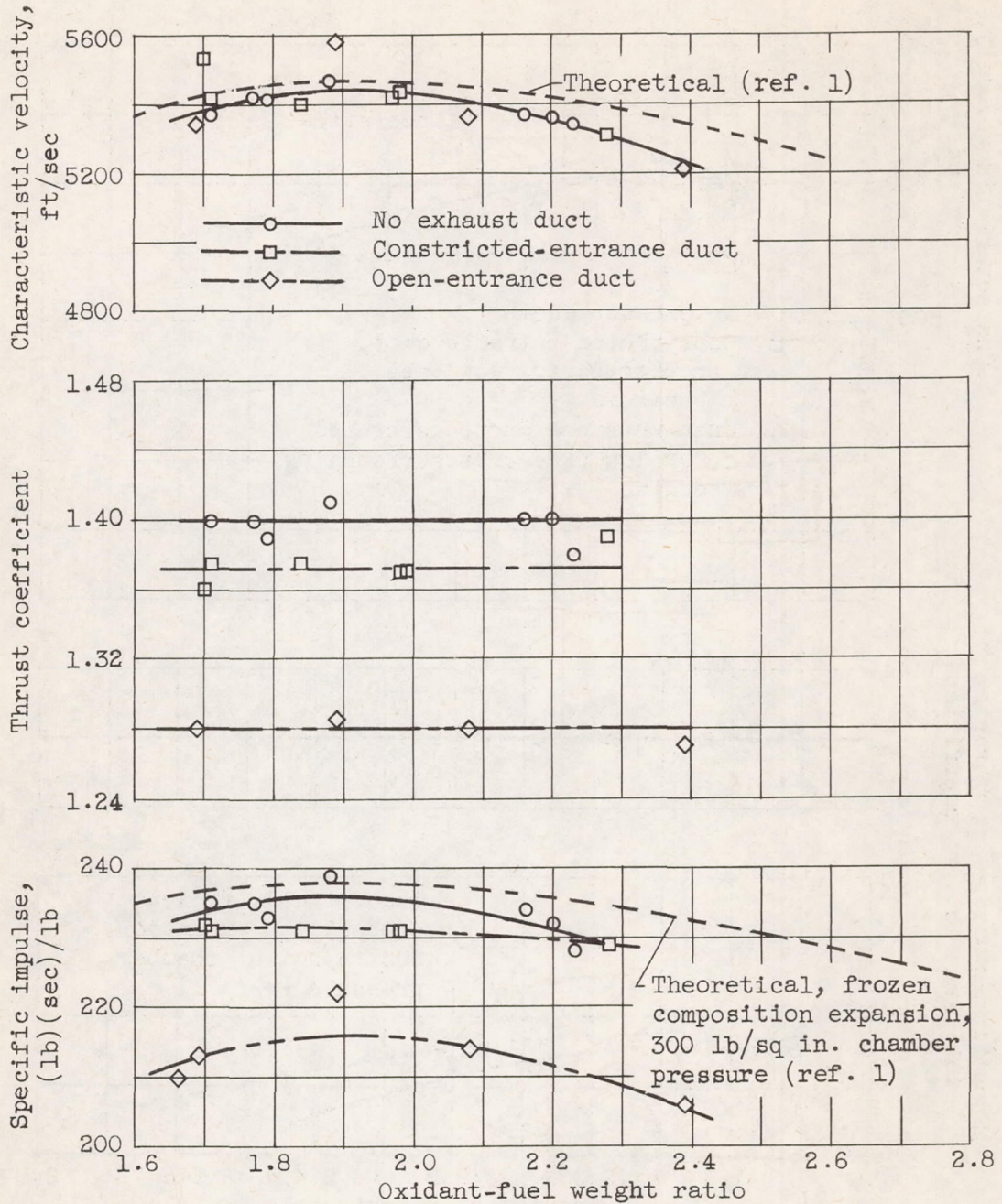
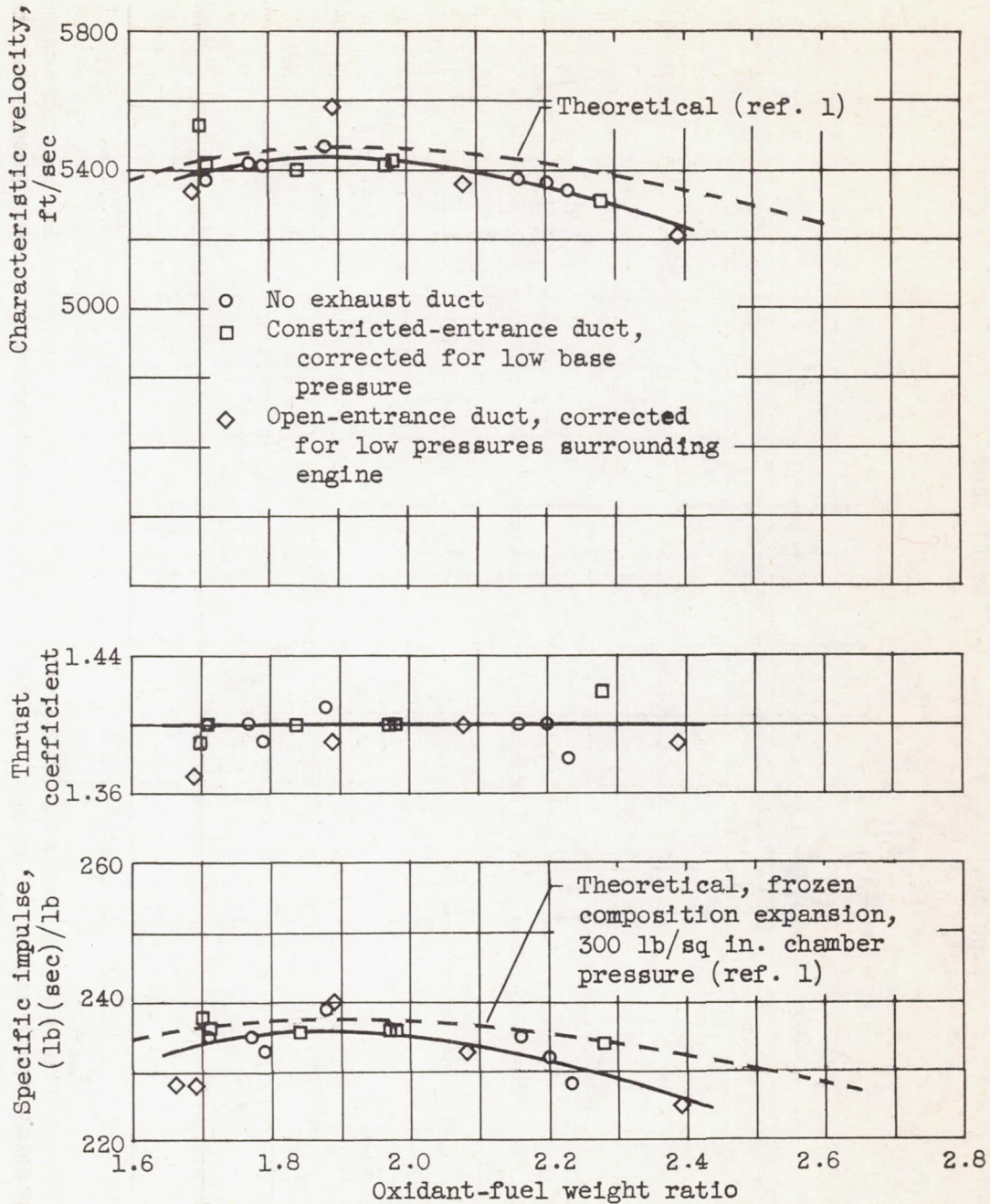

Figure 8. - Constricted-entrance exhaust duct and engine assembly showing locations of pressure measurements. Values given for typical partial vacuums and for areas affected.



(a) Data uncorrected for exhaust-duct effects.

Figure 9. - Theoretical and experimental performance of mixed oxides of nitrogen and ammonia. Thrust, 1100 pounds; chamber pressure, 300 pounds per square inch absolute; four-entry swirl-cup injector.



(b) Data corrected for exhaust-duct effects (see appendix).

Figure 9. - Concluded. Theoretical and experimental performance of mixed oxides of nitrogen and ammonia. Thrust, 1100 pounds; chamber pressure, 300 pounds per square inch absolute; four-entrancy swirl-cup injector.

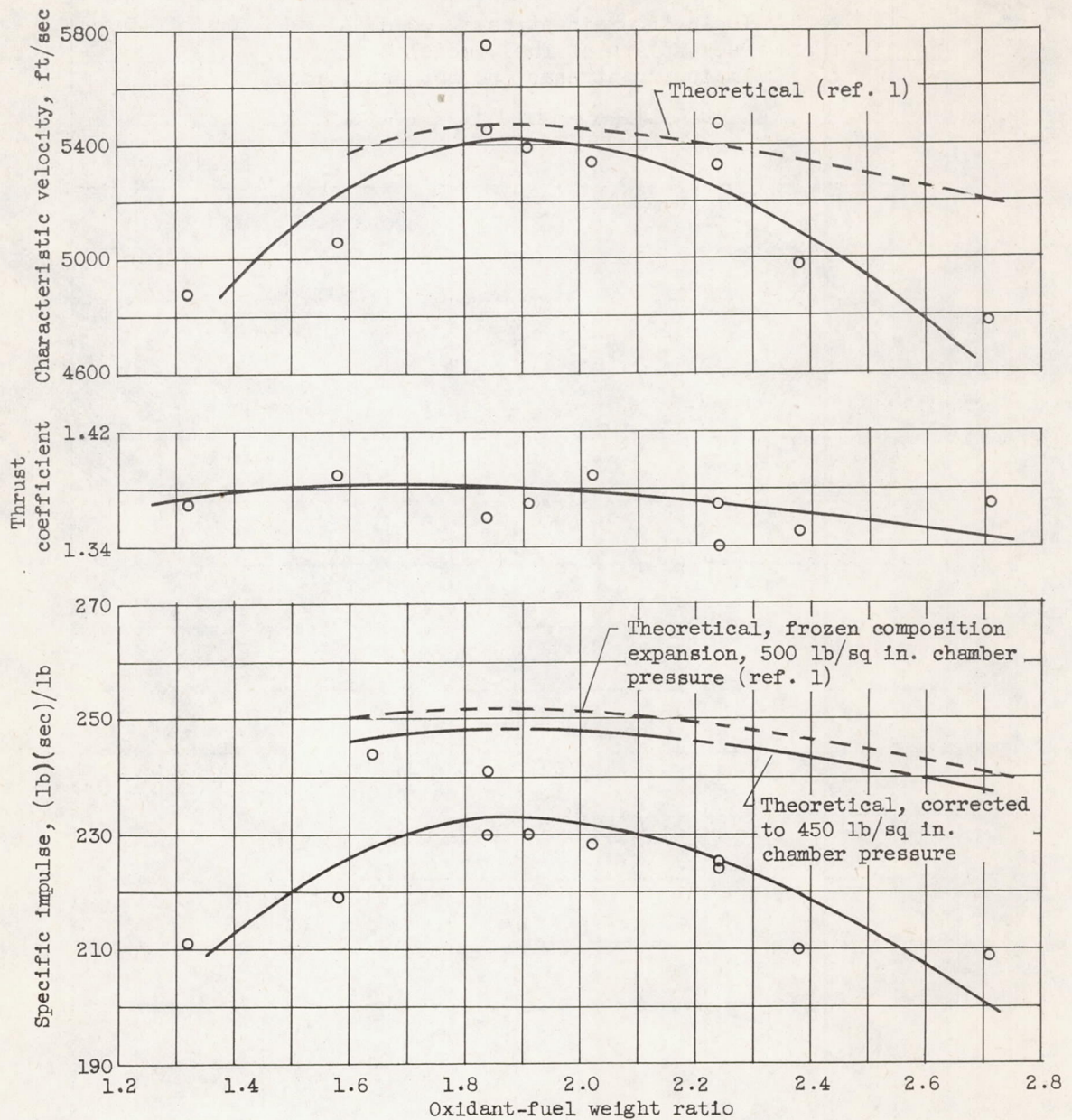

Figure 10. - Theoretical and experimental performance of mixed oxides of nitrogen and ammonia. Thrust, 1600 pounds; chamber pressure, 450 pounds per square inch absolute; triplet impinging jet injector; thrust data corrected for exhaust-duct effects (see appendix).

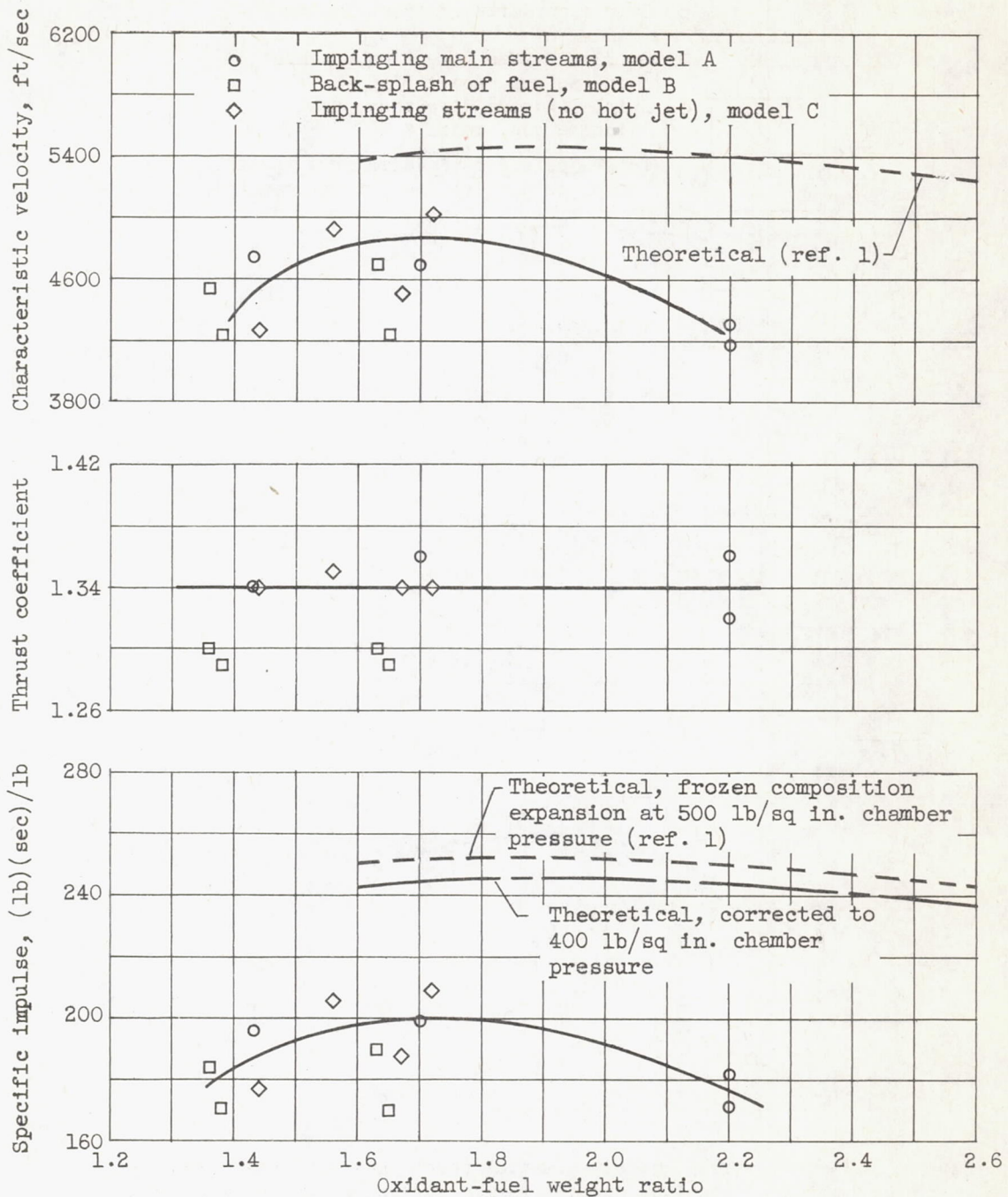

Figure 11. - Theoretical and experimental performance of mixed oxides of nitrogen and ammonia. Thrust, 1400 pounds; chamber pressure, 400 pounds per square inch absolute; hot-jet mixing injector; thrust data corrected for exhaust-duct effects (see appendix).

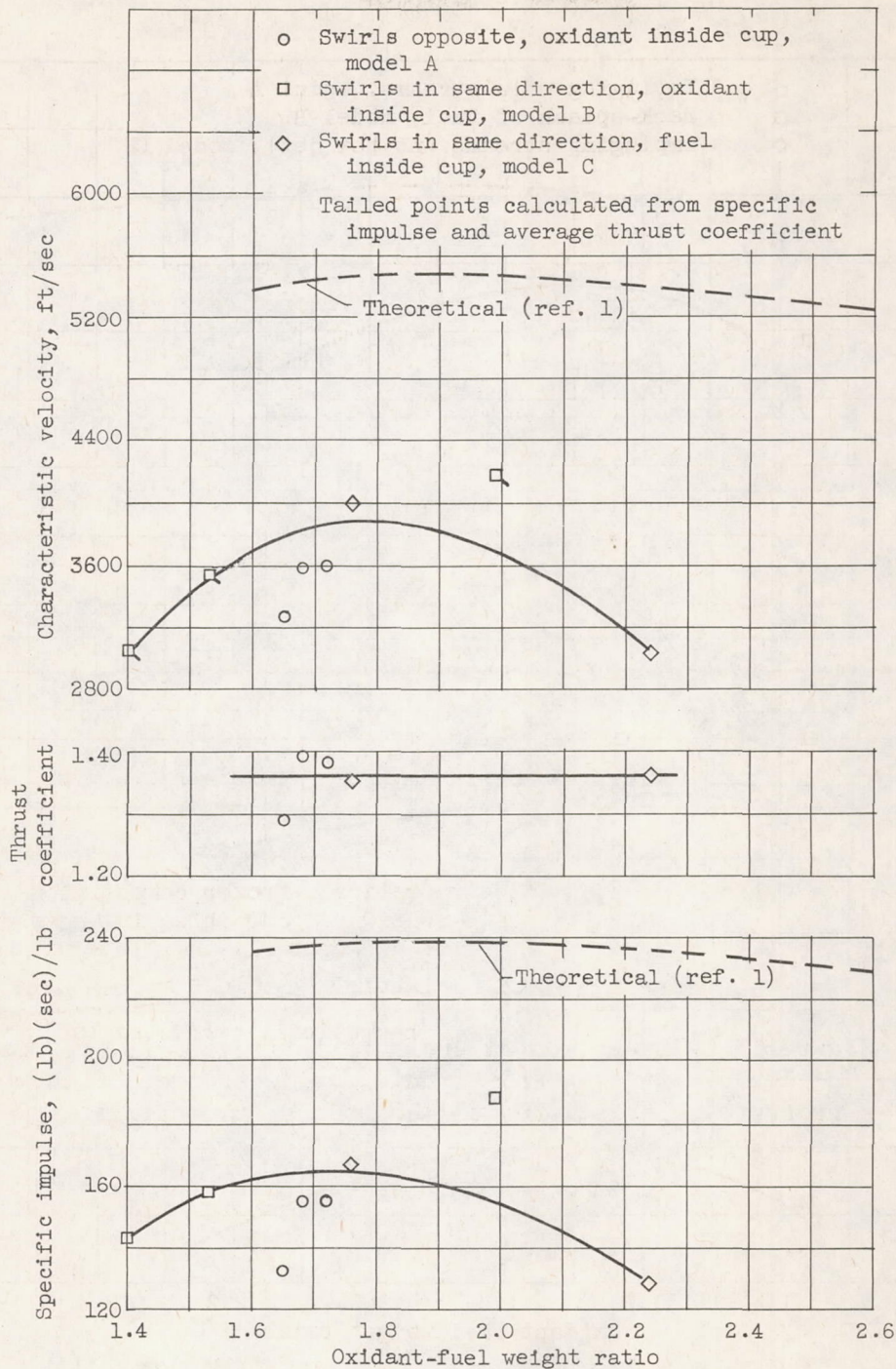

Figure 12. - Theoretical and experimental performance of mixed oxides of nitrogen and ammonia. Thrust, 1000 pounds; chamber pressure, 300 pounds per square inch absolute; concentric swirl injector; thrust data corrected for exhaust-duct effects (see appendix).

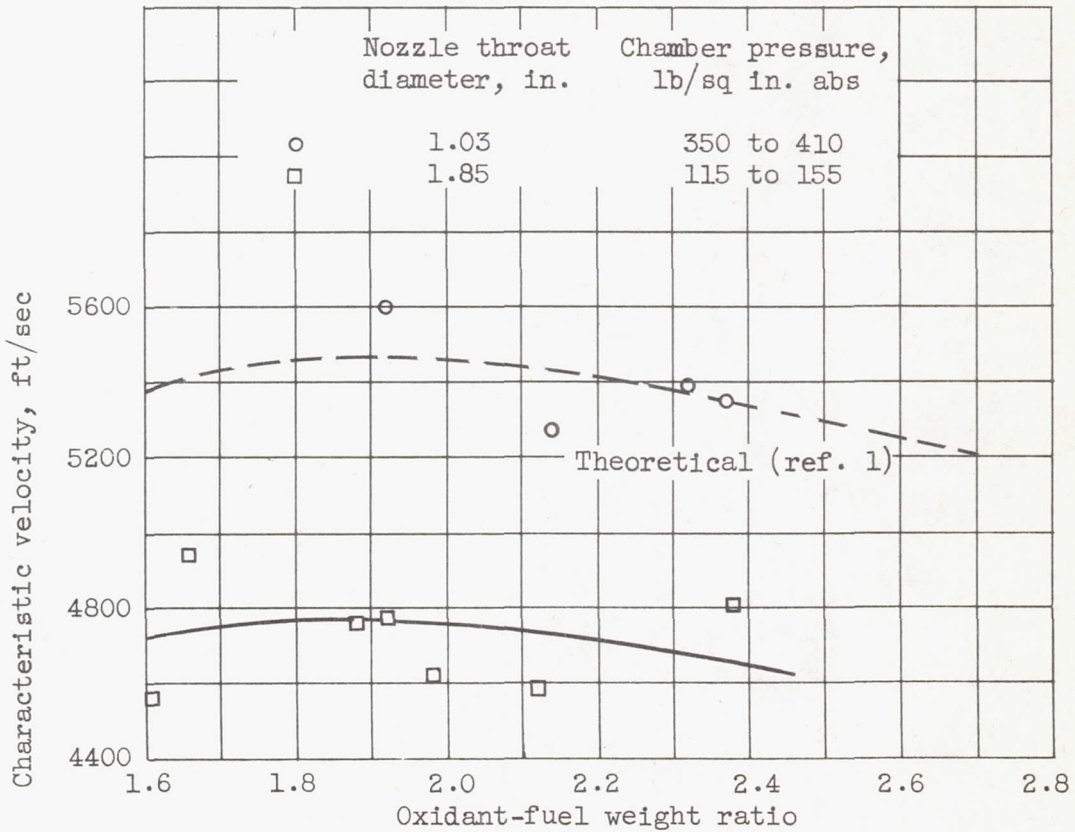

Figure 13. - Experimental characteristic velocity of mixed oxides of nitrogen and ammonia for two ranges of chamber pressure. Thrust, 200 to 480 pounds; two-entry swirl-cup injector.

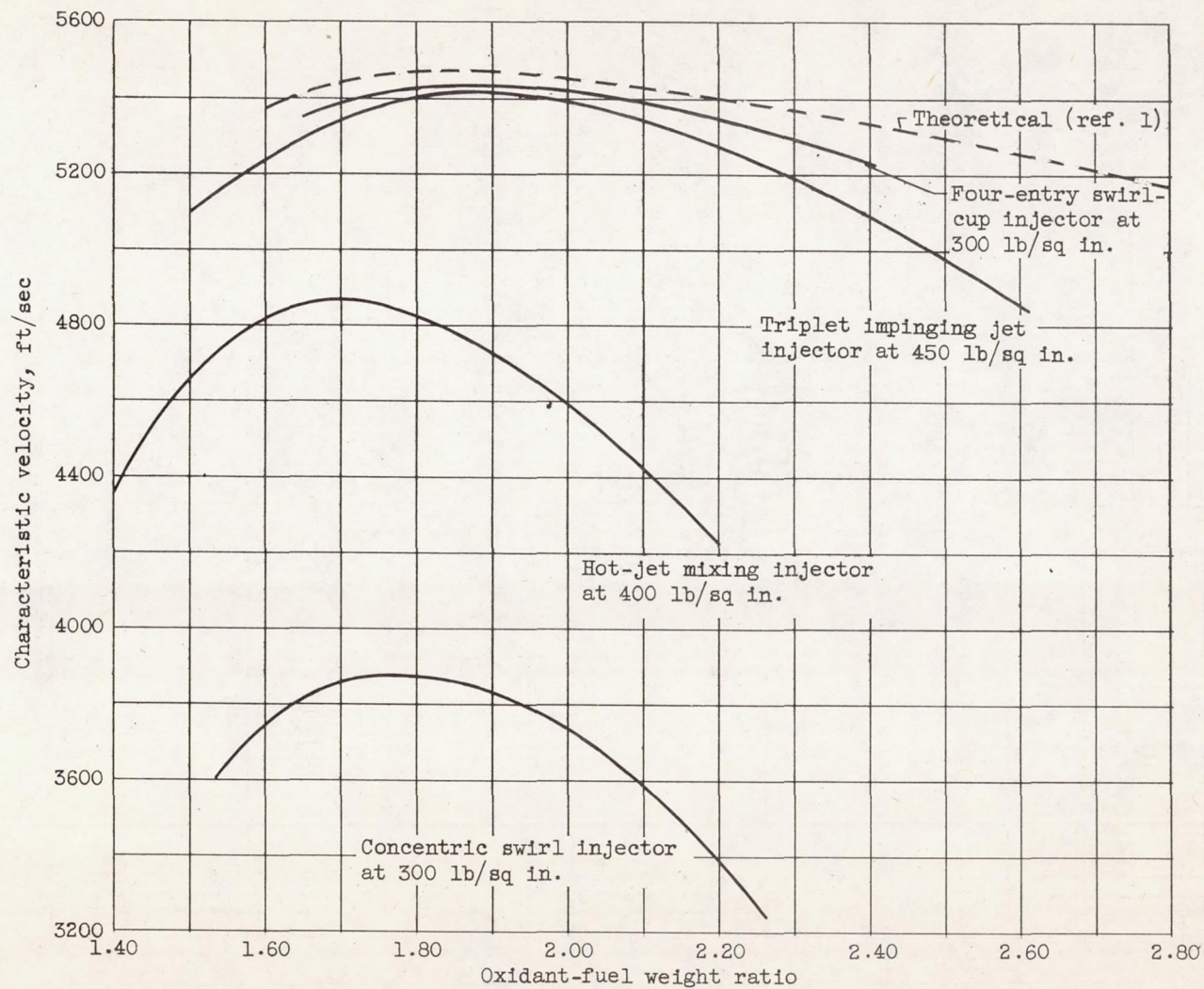
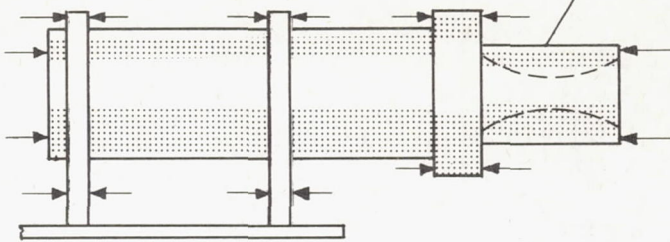
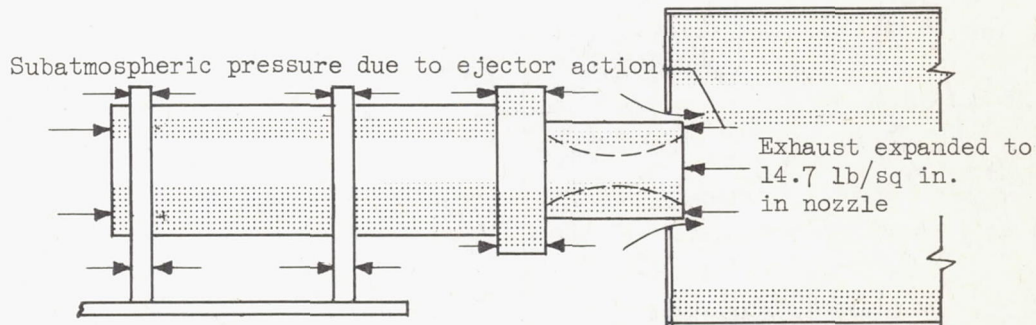

Figure 14. - Theoretical and experimental characteristic velocity of mixed oxides of nitrogen and ammonia for several injectors over a range of conditions.

Nozzle designed for expansion from
300 to 14.7 lb/sq in.



(a) No duct; atmospheric pressure about engine; no resultant pressure forces other than those due to reaction.



(b) Constricted-entrance duct; subatmospheric pressure on nozzle base results in force opposite to reaction thrust.

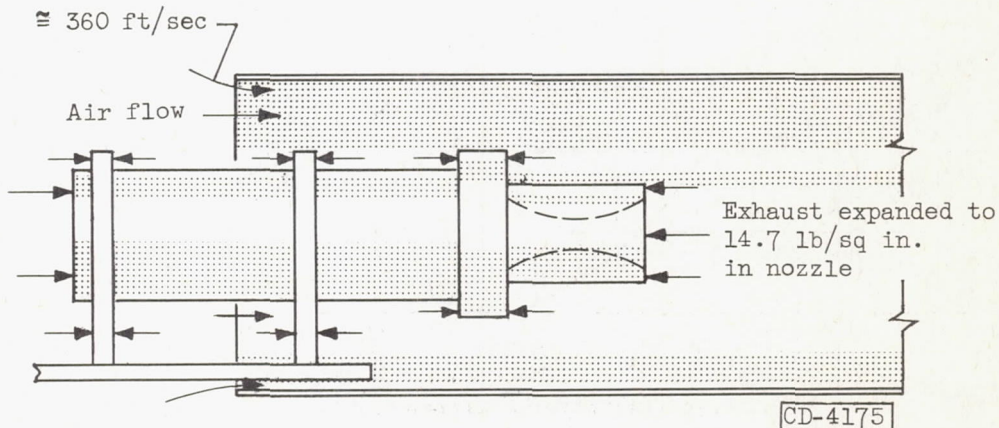

(c) Open-entrance duct; pressure forces due to high-velocity air flow across engine and mounting plus that due to lowered nozzle base pressure give force opposite to engine thrust.

Figure 15. - External pressure forces on engine with and without exhaust ducts.