

CASE FILE
COPY

RM E55CO7



NACA

RESEARCH MEMORANDUM

EXPERIMENTAL EVALUATION OF BORON-HYDROCARBON SLURRY
IN A 16-INCH RAM-JET COMBUSTOR

By William R. Kerlake, E. E. Dangle, and A. J. Cervenka

Lewis Flight Propulsion Laboratory
Cleveland, Ohio

NATIONAL ADVISORY COMMITTEE
FOR AERONAUTICS
WASHINGTON

July 1, 1955
Declassified September 17, 1958

NACA RM E55CO7

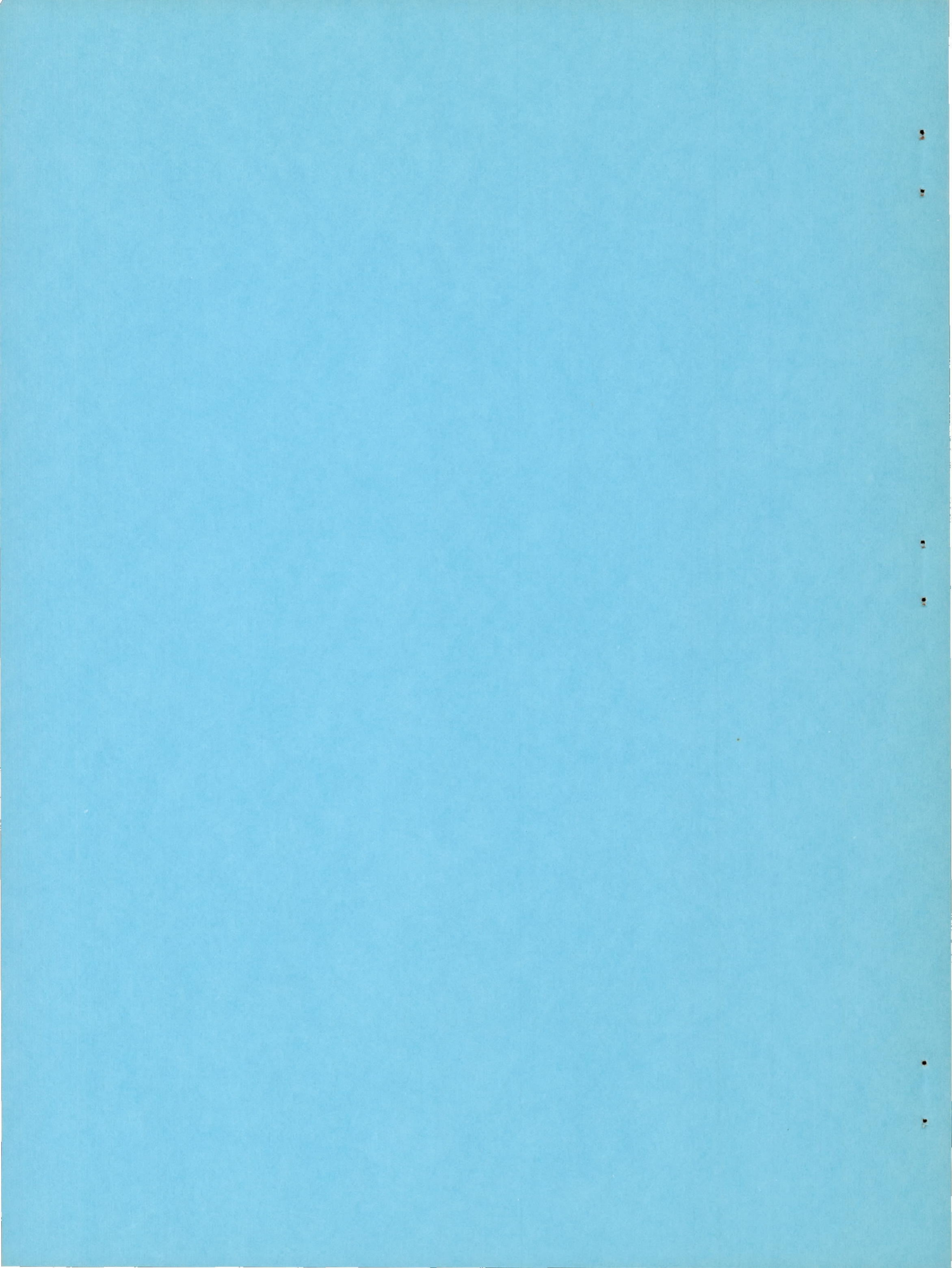

NATIONAL ADVISORY COMMITTEE FOR AERONAUTICS

RESEARCH MEMORANDUM

EXPERIMENTAL EVALUATION OF BORON-HYDROCARBON SLURRY

IN A 16-INCH RAM-JET COMBUSTOR

By William R. Kerslake, E. E. Dangle, and A. J. Cervenka

SUMMARY

The combustion efficiency of a 50-percent-boron - hydrocarbon slurry was evaluated in a 16-inch ram-jet burner. A peak slurry combustion efficiency of 75 percent was usually obtained, and a value of 84 percent was once measured. The connected-pipe burner was run at a simulated flight condition of Mach number 2.85 at an altitude of 68,000 feet, with a 70-percent diffuser recovery giving a burner-inlet pressure of 1 atmosphere and temperature of 570° F.

Three different flame holders were tried, both with and without a fuel-air control sleeve. When air-atomizing slurry injectors were located upstream of the flame holder, maximum combustion efficiency was obtained at fuel-air equivalence ratios above 0.5. Placing the injectors inside the flame holder resulted in maximum combustion efficiency at equivalence ratios below 0.5.

INTRODUCTION

It has been shown analytically (ref. 1) that the range of a supersonic ram-jet aircraft will be greatly increased by the use of high-energy fuels. Boron shows promise of increased aircraft range because of its high theoretical heat of combustion (ref. 2) and high fuel density. For a boron fuel to be useful in long-range flight applications, a high combustion efficiency must be obtained, since range is directly proportional to the heat output of the fuel.

A slurry of boron in a hydrocarbon fuel is desired because of its ease of injection into an engine compared with that of a solid fuel. The penalty of lower heating value of the hydrocarbon is partially compensated for, because the hydrocarbon fills up the voids in the powder and increases the fuel density. A 60-percent-boron - JP-4 fuel slurry would have a relative range equal to pure boron, according to the assumptions and calculations of reference 1 and the assumption that the pure

boron is carried as a powder with a density equal to 30 percent of the solid metal density. Slurry preparation techniques (ref. 3) have advanced so that 50- to 60-percent-boron slurries in JP-4 fuel can be successfully prepared.

Experimental burning of boron slurries is relatively recent, and results are not always consistent. Combustion efficiencies obtained by chemical analysis of combustion products from a 2-inch burner (ref. 4) were near 100 percent for the boron in a 30-percent slurry of boron in JP-3 fuel. Air specific impulse was measured in a 6-inch ram-jet burner for a 30-percent-boron slurry in heptane (ref. 5). The values of air specific impulse corresponded to a range of combustion efficiencies from 50 to over 100 percent of theoretical. When a 50-percent-boron slurry was burned in a 5-inch ram-jet burner (ref. 6), the combustion efficiency for the best combustor configuration investigated ranged from 47 percent at an equivalence ratio of 0.75 to 80 percent at an equivalence ratio of unity. The boron slurry gave a higher heat output than JP-4 fuel only when the fuel-air ratio was above stoichiometric for JP-4 fuel. In addition, the limits of stable combustion were not as wide for the slurry as for JP-4 fuel.

For ram-jet cruise conditions, it is desirable to operate at lean fuel-air ratios. The requirement for high combustion efficiency at these lean ratios suggested burning the slurry at stoichiometric conditions with part of the inlet air and then mixing with the remainder of the air before exhausting. Since such a program was impracticable in a small burner, the 5-inch-burner experiments were extended to a 16-inch burner. Flame-holder geometry, fuel-injection points, and slurry concentration, as well as control of fuel-air mixtures, were varied in an effort to raise the level of the combustion efficiency to a value useful for long-range missile application.

FUELS TESTED

The three varieties of boron slurry fuel prepared for this investigation are listed in table I. The electrolytic, 96-percent-pure boron was used only for a single data point. The method of preparation of the slurry followed that outlined in reference 3. It was necessary to use n-heptane as the carrier fuel to prepare the more concentrated slurries. Analysis of the boron powder is shown in table II.

In addition to being used as a carrier fuel for the slurry, JP-4 was burned as a pilot and auxiliary fuel in the engine. The n-heptane carrier fuel was 99 percent pure. The properties of JP-4 fuel are shown in table III.

APPARATUS

Ram-Jet Engine

The 16-inch ram-jet engine (fig. 1) used in the investigation was composed of a subsonic annular diffuser, a water-cooled combustion chamber 16 inches in diameter, and a water-cooled variable-area exhaust plug. A centerbody terminated with a pilot at its downstream end.

The pilot combustion chamber was formed by extending the centerbody 8 inches. A single fuel nozzle supplied the pilot fuel, and 1.7 percent of the total engine air flow was scooped from the diffuser. The pilot fuel was ignited with a spark plug. The upstream end of the flame holder was attached to the pilot. The over-all length of the engine from the inlet of the diffuser to the nozzle outlet was 180 inches, 90 inches of which was the combustion chamber, measured from the start of the flame holder.

Engine Installation

Installation of the ram-jet engine is shown in figure 2. The 16-inch engine received its air supply from the laboratory combustion air system and exhausted through a central ejector system. Air flow to the engine was controlled by a butterfly valve located upstream of the engine, while the pressure within the engine was controlled by a plug valve located at the engine outlet. Air flow to the engine was metered by an orifice in the supply line. The air was heated by means of a gas-fired heat exchanger and also by a combustor located directly in the air line. The air contained from zero to 13 percent combustion products as a result of the combustor in the line. The engine-outlet gases were cooled in a calorimeter, which consisted of a series of water spray nozzles located at the engine outlet and a thermocouple station 20 feet downstream where the resulting gas and steam temperatures were measured by 16 thermocouples located in equal areas across a 24-inch-diameter duct.

Fuel Systems

Slurry. - The supply tank and injection system for the boron slurry fuel are shown in figure 2. The supply tank consisted of a cylinder in which a piston was mounted free to travel the full length of the cylinder. Up to 40 gallons of slurry fuel was contained below the piston; the pumping medium, ordinary jet fuel, was contained above the piston. The jet fuel flow was metered through a rotameter and then pumped into the tank to the top of the piston. The slurry fuel was forced from the tank through the injectors into the engine. The slurry flow was calculated from measurements of the jet fuel flow, the percentage solids, and the density of each slurry batch.

The slurry injectors, shown in figure 3(a), consisted of an inner tube that carried the slurry fuel surrounded by another tube carrying atomizing air. The outer tube was extended beyond the inner tube and was rolled inward. The rolled outlet orifice of the injector gave the atomizing air a radial component needed to help break up the slurry spray. Injectors of three different sizes were used during phases of the investigation. The inner diameters of the slurry-carrying tubes were 0.250, 0.188, or 0.116 inch. The total atomizing air of the injectors was less than 1 percent of the total engine air flow.

Hydrocarbon. - JP-4 fuel was injected through four conical spray nozzles located 10 inches upstream of the flame holder. The nozzles were rated at 30 gallons per hour at a pressure differential of 100 pounds per square inch.

Control sleeve. - A 11.5-inch-diameter fuel-mixing control sleeve (ref. 7) was utilized for parts of this investigation. The sleeve intercepted approximately 20 percent of the total engine air flow and ducted this air into the upstream half of the combustion zone. The sleeve extended from the fuel injectors to the flame holders.

Combustor Configurations

Six combustor configurations were used in this investigation. Configuration A (fig. 3(a)) consists of a can-type flame holder with 130 percent open area based on the combustion-chamber frontal area. A 5/8-inch annular area remained between the end of the can and the engine wall. The cold-flow pressure-drop coefficient for the combustor is 1.5, based on a measured static differential pressure across the flame holder converted to total pressure and on a dynamic pressure calculated from the engine air flow, static pressure, and combustor cross-sectional area. The six slurry and four jet fuel injectors are equally spaced 2 inches from the engine wall and 10 inches upstream of the start of the flame holder.

The can flame holder of configuration B (fig. 3(b)) is identical to that of configuration A. However, in this configuration a fuel control sleeve is included, and both the JP-4 fuel and the slurry injectors are located in the annulus formed between the control sleeve and the pilot centerbody wall. The injectors are equally spaced 3 inches from the engine wall and the same distance upstream of the flame holder as in configuration A.

Configuration C (fig. 3(c)) is similar to configuration B, except that the slurry injectors are outside the control sleeve 1 inch from the engine wall. Configuration D (fig. 3(d)) is also similar to configuration B, except that only the first four rings of holes in the can flame holder

are present. All the secondary air passes through the annular area between the engine wall and the end of the can flame holder. This modified can flame holder has an open area of 70 percent.

Configuration E is shown in figure 3(e). The can flame holder is the same as in configuration A. Six slurry injectors are positioned through a ring of holes in the can flame holder. Two alternate positions, the second or the fourth ring of holes, are used; the slurry injectors are located $4\frac{1}{4}$ inches from the engine wall or about $1\frac{1}{2}$ inches inside the can and are pointed either costream or contrastream as shown in the inset. The four JP-4 fuel-spray nozzles are 10 inches upstream of the flame holder and 2 inches from the engine wall.

Configuration F (fig. 3(f)) consists of a sloping-baffle flame holder similar to one used in reference 8. The flame holder has 100 percent open area and a cold-flow pressure-drop coefficient of 2.0. The slurry is injected at either of two alternate positions, inside or outside the fuel-air control sleeve. JP-4 fuel is injected 10 inches upstream of the flame holder.

PROCEDURE

The first attempts to burn slurry followed a conventional procedure of injecting slurry upstream of several types of flame holders. In an effort to improve the combustion efficiency, JP-4 fuel was burned in the first half of the flame holder to give a hotter temperature zone in which to burn the slurry. Finally, the slurry was injected inside the can flame holder. For comparison, JP-4 fuel was burned alone in the various configurations.

Operating Conditions

Most of the ram-jet combustion runs were made at the following average operating conditions:

Inlet-air temperature, °F	570
Inlet-air pressure, in. Hg abs	30.0
Inlet-air velocity based on maximum cross-sectional area of combustion chamber, ft/sec	235
Inlet-air weight flow, lb/sec	12.7

These inlet conditions simulated a flight speed of Mach number 2.85 at a 68,000-foot altitude with a 70-percent diffuser pressure recovery.

Combustion Efficiency

Outlet enthalpy of the combustor exhaust gases was determined from a heat-balance system as described in reference 9. The combustion

efficiency was obtained from the ratio of the enthalpy rise of fuel, air, quench water, and engine cooling water to the heating value of the total fuel input. The heating value of the slurry was calculated from the percentage solids in the slurry, the purity of the boron powder times 25,400 Btu per pound, and the lower heating value of JP-4 fuel (18,675 Btu/lb). A lower heating value of 19,157 Btu per pound was used for the n-heptane. The upper heating value of boron was used, because it was assumed that any oxide vapors would condense to solid oxide in the water quench of the calorimeter.

At a given engine operating condition, the quench-water flow was adjusted to a value ensuring quenching of the combustion products and complete vaporization of the water. Mixture temperatures of 700° to 1000° F were maintained at the thermocouple station. Negligible heat loss from the insulated ducting downstream of the water spray was assumed.

Over-All Equivalence Ratio

Over-all equivalence ratio is defined as the ratio of measured to stoichiometric fuel-air ratio. The stoichiometric fuel-air ratio was calculated from individual stoichiometric fuel-air ratios of 0.0680 for JP-4 fuel, 0.0658 for n-heptane, and 0.1044 for pure boron (0.1160 for 90-percent-pure boron). The over-all equivalence ratio was raised to correct for the vitiated air by adding the amount of fuel burned in the preheater.

Slurry-Spray Sampling

At simulated engine conditions. - Photomicrographs were taken of a spray of 50-percent boron slurry injected through a 0.116-inch air-atomizing injector (fig. 3(a)). The slurry was sprayed in the center of an 8-inch-diameter duct 10 inches upstream of a window. The air velocity was 220 feet per second at 575° F and atmospheric pressure. Photographs were taken through the window with a 4-microsecond flash and rotating mirror to stop the motion (ref. 10).

In open air. - A 0.188-inch slurry injector was used to spray 50-percent-boron slurry into still air. The velocity of the atomizing air was sufficient to carry the spray away from the injector. A sheet of paper 18 inches from the injector was momentarily exposed to the spray. The deposits were magnified and photographed.

In engine. - Slurry spray in the engine was momentarily allowed to impinge on a collodium-covered electron microscope grid. The grid was on a probe positioned in line with and 7 inches downstream of a slurry injector in configuration C.

RESULTS

Combustor Configurations

Can combustor. - The combustion efficiencies obtained with configuration A are plotted in figure 4(a). The slurry was injected either costream or contrastream, giving peak efficiencies of 69 and 65 percent, respectively, at an equivalence ratio of 0.8. The two curves were within experimental error of each other. Run 1 was made at slightly higher air pressure, because the altitude exhaust system was inoperable. The JP-4 fuel efficiency was much higher than that of the slurry, the peak efficiency being 88 percent at an equivalence ratio of 0.5. The rich end of the curve was the limit of the JP-4 fuel system.

Can combustor with control sleeve. - Peak combustion efficiencies for configuration B (fig. 4(b)) were obtained at an equivalence ratio of about 0.5. The air flow through the inside of the sleeve was 20 percent of the total air flow. The smaller slurry injectors gave higher efficiencies for run 5 (84 percent) than for run 4 (76 percent). Lowering the inlet-air pressure resulted in a lower efficiency, as seen by comparing runs 5 and 6. Boron of 96-percent purity was used for run 7, which was made at conditions comparable with those of run 5. The slurry for run 7 was more viscous than usual, and the slurry injectors plugged after the first point was taken.

Run 8 is the result of combining JP-4 fuel points obtained before each of several slurry runs. The scatter of points is typical data error due to instrumentation inaccuracy. Any particular curve determined at one time might have less scatter because of a uniform error.

Can with intense pilot. - Combustion efficiencies obtained with configuration C are plotted in figure 4(c). The combination of normal pilot plus additional JP-4 fuel in the first half of the flame holder (primary zone) is defined as the intense pilot. When a slurry of 65-percent boron in n-heptane was injected outside the sleeve (secondary zone) and JP-4 fuel inside the sleeve, an over-all efficiency peak of 77 percent was obtained at an equivalence ratio of 0.9 (run 9). Run 10, with less JP-4 fuel inside the sleeve, had lower combustion efficiencies. JP-4 fuel injected alone inside the sleeve gave 85 to 90 percent combustion efficiency in run 8 (fig. 4(b)). Comparison of runs 9 and 11 shows that the effect of using vitiated air is small.

Modified can combustor with control sleeve. - The level of combustion efficiency of the modified can (configuration D, fig. 4(d)) was equivalent to that of the unmodified can (fig. 4(b)). Higher efficiency was obtained with smaller injectors. The residence time of a particle in the combustion chamber was increased 30 percent by decreasing the air velocity (run 14). The trend of run 14 is doubtful, because injector plugging occurred after the first point was taken. The JP-4 fuel efficiency was again higher than the slurry efficiency.

Can with internal injection. - Figure 4(e) shows combustion efficiencies obtained with configuration E. If it is assumed that the JP-4 fuel burns with higher efficiency than the boron, the highest boron efficiencies resulted when the slurry was injected contrastream at the fourth row of holes. Injecting costream at the second row resulted in a lower efficiency. Additional JP-4 fuel upstream of the flame holder gave no significant improvement in efficiency, while JP-4 fuel alone again burned with higher efficiency than slurry.

Sloping-baffle combustor. - Combustion efficiencies for configuration F are presented in figure 4(f). A 50-percent-boron - JP-4 fuel slurry injected into the primary zone gave lower efficiencies (run 20) than were obtained with the can combustor (run 4). Injecting slurry into the secondary zone and JP-4 fuel into the primary zone (run 21) resulted in the best efficiency for the intense pilot scheme (normal pilot plus JP-4 fuel inside the sleeve). The addition of JP-4 fuel, however, lowered the boron percentage of the total fuel to 38 percent at the rich end and 23 percent at the lean end of run 21. The more efficient burning of JP-4 fuel is again noted by comparing run 21 with run 22, in which less JP-4 fuel was added in the primary zone.

Slurry Atomization

The average diameter of the prime boron particles was 1 micron, but the spray produced larger groups or clusters of prime particles. These groups varied in size up to 200 microns. Figure 5(a) is a photomicrograph of a 50-percent-boron slurry spray taken with the 4-microsecond flash and a rotating mirror (ref. 10). A range of 5- to 100-micron particles can be seen. The greatest number of particles are 30 microns in diameter. The technique does not show particles smaller than 5 microns. Figure 5(b) shows a photomicrograph of 50-percent boron in JP-4 fuel sprayed through a 0.188-inch injector into open air. The sample was collected on a piece of paper 18 inches from the injector.

The slurry spray pattern was subject to errors because of the absence of a heated airstream passing over the injector, as occurs in the engine. In addition, there is the possibility that a large drop might be the result of several smaller drops striking the same spot on the paper.

The sampling attempt using the electron microscope grid failed to produce quantitative results, because the hot airstream destroyed the collodium film. Observation of fragments of remaining collodium film indicated the particle size range to be 1 to 100 microns. The 1-micron particles were similar to those in electron micrographs of the original boron powder (ref. 3).

The slurry spray was believed to be formed in a manner similar to an ordinary liquid spray, but the hydrocarbon quickly evaporated in the 575° F airstream, leaving clusters of boron powder. The size of these clusters was assumed to be proportional to the original slurry spray droplets. The hydrocarbon evaporated at a rate such that the slurry spray was a dry dust 7 inches downstream of the injector.

Engine Deposits

The following table is an analysis of chips of deposits formed on the flame holder and exhaust plug during run 4:

Source of sample	Boron, percent		Unburned solid carbon, percent
	Burned	Unburned (solid)	
Flame holder	58	31	11
Exhaust plug	50	49	1

Figure 6(a) is a photograph of the can combustor after run 4, in which slurry was burned for 15 minutes. Figures 6(b) and (c) are photographs of the can combustor after a run in which slurry was internally injected for 12 minutes. The lack of deposits in the lower left portion in figure 6(b) resulted from a plugged slurry injector located in that sector. Figure 6(d) is a photograph of the sloping-baffle combustor after a run similar to run 22. The run data were not reported, because slurry injector plugging occurred.

Deposits also collected on the exhaust plug and in the pilot. These deposits varied from 1/8 inch to several inches, depending upon the run. The amount of deposits was not known until the combustor was cleaned for the next run. No change was noted in the combustion efficiency of JP-4 fuel before and after the slurry had deposited up to 1/8 inch on the flame holder. Thicker deposits on the flame holder shifted the combustion efficiency with JP-4 fuel in an unpredictable manner.

Flame-Holder Burn-Out

Minor flame-holder burn-outs (1 to 3 sq in. of metal) occurred in approximately half the total number of runs. Burn-outs of 10 to 15 square inches of metal occurred during run 4 (fig. 6(a)), run 13 (modified can), and run 21 (sloping baffle). The severity of the burn-out was usually greater for runs with higher combustion efficiency. The average life of a flame holder was increased by increasing the thickness of the material from 3/32 to 3/16 inch.

DISCUSSION

Slurry Atomization

Although fuel distribution and flame-holder geometry were the principal variables, a discussion of slurry atomization is included first because of its possible great effect on combustor efficiency. The combustion of boron is probably a surface-phase reaction, as evidenced by boron vapor pressure (ref. 11). As shown in the following table, the vapor pressure is extremely small at 3300° R, which is the theoretical flame temperature that would be obtained if only the hydrocarbon of the slurry burned in a stoichiometric mixture of 50-percent-boron slurry and air:

Temperature, °R	Boron vapor pressure, mm Hg
3300	^a 0.01
3600	.25
4320	24.6
4680	138
5080	760

^aExtrapolated.

If the combustion process is a surface-phase reaction, the rate of burning of the boron particle will be directly proportional to its surface area, and the time to burn one particle of boron will be proportional to its size. The results of spraying slurry into a heated airstream indicate that part, if not all, of the clusters are unbroken before reaching the flame holder.

The 100-micron clusters of boron particles might also pass through the combustor and never burn any appreciable amount because of their reduced surface area. If these clusters are the cause of low combustion efficiency, the results could be interpreted as follows:

(1) Smaller slurry injectors gave better efficiency because of increased atomization, shown by runs 4 and 5 (fig. 4(b)) and runs 12 and 13 (fig. 4(d)).

(2) Most of the atomization was accomplished in the injector tip, because there was no increase in efficiency by pointing the injectors contrastream as in run 2 (fig. 4(a)).

Combustor Configurations and Fuel

The peak in a combustion-efficiency curve can be shifted by controlling fuel-air mixtures. Configuration A had no control sleeve; consequently, its peak occurred (fig. 4(a)) at a richer equivalence ratio than that of any other configuration. This maximum equivalence ratio was 0.8 instead of 1.0 as might be expected (ref. 6) because of air flow through the annular area between the end of the can and the 16-inch-diameter burner wall.

To keep the combustion efficiency high at lean fuel-air mixtures, the slurry was burned at stoichiometric conditions with part of the inlet air and then mixed with the remainder of the air before exhausting. Injecting the slurry inside a control sleeve (configuration B) produced a richer local fuel-air mixture and thereby shifted the peak to about 0.5 equivalence ratio. The combustor efficiency level remained low (70 to 75 percent).

Another attempt was made to control the fuel-air mixing in the combustor by injecting the slurry inside the flame holder. When the slurry was introduced progressively toward the upstream end of the can, the peak combustion efficiency was shifted toward small equivalence ratios, because less air was available locally for combustion. The leanest peaks were obtained with runs 16 and 19 (fig. 4(e)), in which all the slurry was sprayed contrastream. Contrastream injection is similar to using a control sleeve, because it concentrates the fuel in the first part of the can; while costream injection spreads out the fuel as when no control sleeve is used. The addition of JP-4 fuel with no control sleeve also shifted the peak higher toward an equivalence ratio of 0.8 (fig. 4(a)). The shifting of the peaks suggests a combination of injection positions to obtain broad fuel-air operation at maximum combustion efficiency.

In an effort to raise the level of combustion efficiency, the modified-can and sloping-baffle combustors were tried. The new designs provided for additional burning time at a high local temperature before the diluent air was mixed with the reaction mixture. It was thought that the reaction might not be complete when mixed with diluent air and that the cooling would quench the reaction. The combustion-efficiency level was slightly raised with the modified can, but slightly lowered (run 21, fig. 4(f)) with the sloping-baffle combustor.

Another attempt to raise the level of combustion efficiency was the introduction of a larger, more intense pilot. It was thought that the boron particles might burn better if boosted to a hotter temperature with the larger piloting zone. The additional JP-4 fuel needed for the pilot, however, reduced the percentage of boron in the total fuel. To keep the boron percentage high, a more concentrated slurry was made with *n*-heptane as the carrier. The runs with larger additions of JP-4 fuel (run 9, fig. 4(c) and run 22, fig. 4(f)) were more efficient for two possible reasons:

(1) The greater percentage of the total fuel was hydrocarbon, which burned more efficiently than the slurry, or (2) the combustion of boron itself actually increased, assuming a constant efficiency for the hydrocarbon.

All the combustion-efficiency data are the result of burning a mixture of solid boron and hydrocarbons. To establish how efficiently each is burning would necessitate an analysis of the exhaust products. The analysis was not made, but JP-4 fuel was burned alone in the various combustors, with a resulting higher efficiency. If it is assumed that the hydrocarbon burns with the same efficiency at the same equivalence ratio in the presence of boron particles, then the efficiency of the boron is much lower than that for the slurry.

Low Combustion Efficiency of Boron

The apparently low combustion efficiency of boron might be caused by any one or a combination of the following phenomena:

(1) Low burning rate of boron due to chemical inertness. Samples of the boron powder were analyzed and were found to contain from 8 to 15 percent hydrogen-peroxide-insoluble boron of the 90-percent free boron in the powder. Presumably, the peroxide-insoluble boron would be more difficult to burn. Burning rate or reactivity might be increased by new techniques that produce either a different crystal structure or a reduction of chemical impurities or contaminants.

(2) Condensation of boron oxide B_2O_3 on the surface of unburned boron particles.

(3) Low reactivity of boron compared with a fuel such as a hydrocarbon or even magnesium that can vaporize and burn as a gas rather than as a solid.

(4) Inadequate fuel atomization. Large particles (100 microns) consisting of clusters of boron particles were produced by the fuel injector. The burning time of a liquid fuel droplet is proportional to the square of the diameter. For example, a 100-micron drop of liquid fuel would require 10,000 times longer to burn than a 1-micron drop. The clusters might be present in the bulk slurry or be produced by the injector process, but it is not known whether they break up while passing through the flame zone. Improved injection methods or better slurry additives might promote complete break-up of the clusters before or during the combustion process.

(5) Poor burner design. Most burners or flame holders for boron are designed similarly to those for burning an easily vaporized liquid fuel. Perhaps more turbulence is necessary to mix the solid boron particles with unburned oxygen.

(6) Askew fuel patterns caused by injector plugging. Sections where plugging occurred were fuel-starved, while the remaining injectors were overloaded with slurry, resulting in poorer atomization and fuel-rich sections.

(7) Dissociation of CO_2 to CO . Any heat of dissociation is not recovered in the calorimeter if the exhaust products are frozen by the quench-water spray. A chemical analysis would be necessary to determine whether reassociation occurs. The dissociation error could amount to a 10-percent decrease in the measured combustion efficiency (ref. 6) for operation at stoichiometric fuel-air ratio. The error drops to less than 1 percent decrease for equilibrium operation at an equivalence ratio of 0.7.

(8) Deposits on the flame holder. Deposits can cause a decrease or an increase in combustion efficiency, depending on whether they produce a poorer or a better flow recirculation in the flame holder.

SUMMARY OF RESULTS AND CONCLUSIONS

In an evaluation of a boron-hydrocarbon slurry in a 16-inch ram-jet burner at a simulated flight condition of Mach 2.85 at 68,000 feet the following results were obtained:

1. Most of the combustion efficiencies of 50-percent boron in JP-4 fuel fell in a range of 60 to 75 percent of the theoretical combustion efficiencies.

2. A peak efficiency of 84 percent was obtained with a can combustor with a fuel-air control sleeve.

3. The same number of smaller slurry injectors produced better combustion efficiencies than larger injectors for equivalent conditions.

4. A lower combustion pressure resulted in a lowering of the combustion efficiency.

5. Internal injection of the slurry shifted the peak in combustion efficiency to a lower equivalence ratio without changing the level of the peak.

Boron has theoretical potential value as a ram-jet fuel because of its large heat of combustion, high density, and high air specific impulse. It also offers stable storage and nontoxic properties. The full potential heat output of boron has not been realized. Part of the loss is due to use of impure (90 percent) boron, and part is due to low combustion efficiency. Work should be continued on a small scale to define the exact

nature of the low combustion efficiency. If the full heat output is not achieved, the nuisance problems of injector plugging, flame-holder burn-out, and deposit formation need not be solved.

Lewis Flight Propulsion Laboratory
National Advisory Committee for Aeronautics
Cleveland, Ohio, March 9, 1955

REFERENCES

1. Henneberry, Hugh M.: Effect of Fuel Density and Heating Value on Ram-Jet Airplane Range. NACA RM E51L21, 1952.
2. Breitwieser, Roland, Gordon, Sanford, and Gammon, Benson: Summary Report on Analytical Evaluation of Air and Fuel Specific-Impulse Characteristics of Several Nonhydrocarbon Jet-Engine Fuels. NACA RM E52L08, 1953.
3. Goodman, Irving A., and Fenn, Virginia O.: Preparation and Properties of Concentrated Boron-Hydrocarbon Slurry Fuels. NACA RM E54F18a, 1954.
4. Lord, Albert M.: An Experimental Investigation of Combustion Properties of a Hydrocarbon Fuel and Several Magnesium and Boron Slurries. NACA RM E52B01, 1952.
5. Garmon, R. C., Longo, A., and Wolf, R. L.: Combustion of Boron. Final Rep., Experiment, Inc., Nov. 1, 1953.
6. Reynolds, Thaine W., and Haas, Donald P.: Performance of Slurries of 50-Percent Boron in JP-4 Fuel in 5-Inch Ram-Jet Burner. NACA RM E54D07, 1954.
7. Cervenka, A. J., and Dangle, E. E.: Effect of Fuel-Air Distribution on Performance of a 16-Inch Ram-Jet Engine. NACA RM E52D08, 1952.
8. Cervenka, A. J., Bahr, D. W., and Dangle, E. E.: Effect of Fuel-Air Ratio Concentration in Combustion Zone on Combustion Performance of a 16-Inch Ram-Jet Engine. NACA RM E53B19, 1953.
9. Cervenka, A. J., and Miller, R. C.: Effect of Inlet-Air Parameters on Combustion Limit and Flame Length in 8-Inch-Diameter Ram-Jet Combustion Chamber. NACA RM E8C09, 1948.
10. Ingebo, Robert D.: Vaporization Rates and Drag Coefficients for Isooctane Sprays in Turbulent Air Streams. NACA TN 3265, 1954.

11. Luft, N. W.: The Thermodynamic Properties of some Metals and their Oxides at High Temperatures. Tech. Memo. No. 14/M/48, Explosives Res. & Dev. Establishment, Ministry of Supply, Sept. 1948.

TABLE I. - ANALYSIS OF BORON SLURRY FUELS

	50-Percent boron (90 percent pure) in JP-4	65-Percent boron (90 percent pure) in <u>n</u> -heptane	50-Percent boron (96 percent pure) in JP-4
Boron powder, percent	50.7	63.4	53.2
Carrier fuel, percent	47.5	35.1	45.0
Wetting agent (glycerol sorbitan laurate), percent	1.6	1.5	1.3
Thickening agent (aluminum octoate), percent	.2	----	.5
Density, lb/cu ft	74.3	79.5	76.7
Lower heating value, Btu/lb	20,600	21,400	21,600

TABLE II. - ANALYSIS OF BORON POWDER

	90-Percent-pure boron	96-Percent-pure boron
Method of production	Magnesium-thermic reduction	Electrolytic
H ₂ O soluble boron, percent	0.0-0.5	0.56
Weight loss at 105° C, percent	0.0-0.5	0
Free boron, percent	89.0-90.2	96.3
Acidity ^a of water extract, pH	5.4-6.0	----
Average particle size, microns	1	1

^aThe analytical procedure used for determining the pH is outlined in reference 3.

TABLE III. - SPECIFICATIONS AND ANALYSIS OF MIL-F-5624A,
GRADE JP-4, ENGINE FUEL

	Specifications	Analysis
A.S.T.M. distillation		
D 86-46, °F:		
Initial boiling point		140
Percentage evaporated:		
5		199
10	250 (max.)	224
20		250
30		270
40		290
50		305
60		325
70		352
80		384
90		427
Final boiling point	550 (max.)	487
Residue, percent	1.5 (max.)	1.2
Loss, percent	1.5 (max.)	0
Specific gravity, °A.P.I.	40° (min.), 58° (max.)	53.5°
Reid vapor pressure, lb/sq in.	2.0 (min.), 3.0 (max.)	2.7
Hydrogen-carbon ratio		0.169
Net heat of combustion, Btu/lb	18,400 (min.)	18,675

TABLE IV. - PERFORMANCE OF BORON SLURRY IN 16-INCH RAM-JET COMBUSTOR

Run	Slurry injector size	Over-all equivalence ratio	Combustion efficiency, percent	Inlet-air -				Fuel weight flow, lb/hr				Boron in total fuel, percent		
				Weight flow, lb/hr	Pressure, in, Hg abs	Temperature, °F	Velocity, ft/sec	Slurry	Engine JP-4	Pre-heater JP-4	Pilot gaso-line			
Configuration A														
1	0.188	0.389	34.7	45,600	31.8	575	221	1,500	0	87	58	62.2		
		.507	53.4	46,600	32.9	562	216	2,020	↓	↓	↓	62.8		
		.745	69.3	46,300	35.6	560	198	2,980	↓	↓	↓	63.4		
		.900	67.3	46,000	37.1	570	191	3,590	↓	↓	↓	63.6		
		1.105	63.1	46,000	39.0	570	181	4,430	↓	↓	↓	63.7		
2	0.116	0.428	29.2	44,000	29.5	583	231	1,500	0	95	43	48.6		
		.480	44.8	52,900	29.0	578	282	2,060	↓	↓	↓	48.9		
		.547	60.0	45,300	29.2	578	240	2,000	↓	↓	↓	48.9		
		.619	61.9	52,600	29.5	578	276	2,660	↓	↓	↓	49.2		
		1.031	59.7	44,500	29.5	578	233	3,760	↓	↓	↓	49.4		
3	None	0.186	50.0	44,400	28.6	568	238	0	510	87	50	0		
		.257	65.9	49,600	29.6	478	234	↓	819	0	50	↓		
		.279	62.1	48,500	31.7	591	239	↓	847	105	43	↓		
		.283	78.0	45,700	30.0	564	232	↓	840	95	10	↓		
		.317	73.4	42,900	30.0	585	222	↓	839	85	58	↓		
		.338	69.0	49,200	30.3	492	230	↓	1,120	0	12	↓		
		.357	79.5	45,300	31.5	579	224	↓	1,010	118	45	↓		
		.413	83.1	46,000	30.0	562	234	↓	1,250	95	0	↓		
		.416	87.2	44,300	30.0	572	227	↓	1,200	85	52	↓		
		.428	79.6	48,700	32.7	588	233	↓	1,320	105	47	↓		
		.472	86.9	42,800	30.0	570	220	↓	1,290	85	42	↓		
		Configuration B												
		4	0.260	0.239	62.7	46,100	29.8	570	237	738	0	406	62	46.1
.375	72.3			45,800	31.8	↓	222	1,190	↓	↓	↓	47.5		
.467	78.4			45,800	32.5	↓	217	1,500	↓	↓	↓	48.0		
.474	70.0			46,000	32.3	↓	219	1,540	↓	↓	↓	48.1		
.570	69.8			45,800	33.0	↓	214	1,850	↓	↓	↓	48.4		
.660	75.0			46,000	34.3	↓	206	2,170	↓	↓	↓	48.6		
.716	68.8			45,800	34.3	↓	206	2,350	↓	↓	↓	48.7		
.870	50.8			46,000	30.5	↓	232	2,890	↓	↓	↓	49.0		
5	0.116	0.204	73.2	46,000	30.0	590	242	995	0	100	37	48.2		
		.321	82.4	45,900	30.2	595	260	1,590	0	100	37	48.9		
		.427	84.0	45,600	30.2	595	237	2,120	0	100	41	49.1		
6	0.116	0.342	72.8	29,500	20.0	588	230	813	0	80	12	49.3		
		.450	74.5	28,400	21.4	587	207	1,030	↓	↓	↓	49.4		
		.645	70.0	28,000	22.0	588	200	1,470	↓	↓	↓	49.7		
		.786	62.4	28,000	20.9	588	209	1,790	↓	↓	↓	49.7		
		.927	56.5	28,000	21.4	590	205	2,110	↓	↓	↓	49.8		
		1.082	53.7	28,000	22.2	590	197	2,470	↓	↓	↓	49.9		
7	0.116	0.299	63.2	44,100	29.8	580	228	1,045	0	86	41	51.2		

TABLE IV. - Continued. PERFORMANCE OF BORON SLURRY IN 16-INCH RAM-JET COMBUSTOR

Run	Slurry injector size	Over-all equivalence ratio	Combustion efficiency, percent	Inlet-air -				Fuel weight flow, lb/hr				Boron in total fuel, percent
				Weight flow, lb/hr	Pressure, in. Hg abs	Temperature, °F	Velocity, ft/sec	Slurry	Engine JP-4	Pre-heater JP-4	Pilot gaso-line	
Configuration B, continued												
8	None	0.248	87.7	48,500	31.6	588	240	0	681	415	30	0
		.249	82.4	48,400	30.0	596	248		681	415	30	
		.260	85.8	45,800	30.2	570	233		658	406	41	
		.270	86.2	45,100	29.5	580	237		784	100	43	
		.303	87.6	45,300	31.5	576	222		862	86	40	
		.351	86.0	47,600	30.0	596	250		950	415	30	
		.360	88.1	29,700	18.1	572	252		680	80	16	
		.363	90.7	48,500	32.1	586	235		1,010	415	30	
		.425	89.4	49,200	32.6	582	234		1,230	415	2	
		.456	86.9	47,700	30.0	592	250		1,250	415	30	
		.499	91.5	48,400	30.0	595	253		1,390	415	30	
		.502	88.2	29,700	17.8	572	256		956	80	16	
Configuration C												
9	0.188	0.443	58.4	48,800	34.2	516	207	836	831	0	19	32.2
		.606	67.9	47,600	35.5	524	196	1,410		95		40.5
		.750	75.0	47,800	37.7	527	187	2,040		95		45.8
		.985	75.8	47,200	39.8	530	174	2,970		95		50.5
10	0.188	0.370	31.2	47,500	33.2	530	211	811	536	95	19	38.5
		.481	47.5	49,100	34.7	506	202	1,410		0		46.6
		.617	63.5	49,400	36.6	498	194	2,040		0		51.0
		.809	66.1	50,300	38.6	490	185	2,970		0		54.7
11	0.188	0.495	65.1	48,700	30.0	594	254	772	830	415	30	29.6
		.647	61.6	48,700	30.4	590	250	1,350	830	415	30	38.1
		.814	73.3	48,200	30.6	584	244	1,940	830	415	2	43.1
		1.010	73.0	50,500	30.5	480	232	2,890	840	415	30	47.7
		1.052	62.0	48,200	30.0	566	245	2,840	830	415	30	47.9
Configuration D												
12	0.250	0.237	22.7	47,600	28.5	560	254	757	0	415	62	46.2
		.332	59.8	47,000	30.7	560	235	1,090				47.3
		.449	67.5	47,500	32.5	560	222	1,500				48.0
		.560	72.3	47,200	30.0	565	240	1,880				48.4
		.697	70.5	46,700	30.5	565	234	2,330				48.7
		.808	62.5	46,400	30.7	565	231	2,730				48.9
		13	0.188	0.308	53.1	46,300	29.8	570	238	977	0	415
.460	77.8			46,300	30.3	570	234	1,500				48.1
.606	76.1			46,300	29.8	568	238	2,000				48.6
.791	72.1			46,300	29.8	568	238	2,630				48.9
14	0.188	0.300	61.5	37,000	30.2	556	185	738	0	415	39	47.5
15	None	0.375	91.4	47,200	30.1	562	239	0	978	415	60	0
		.509	92.7	47,200	31.0	560	231	0	1,360		54	0

TABLE IV. - Concluded. PERFORMANCE OF BORON SLURRY IN 16-INCH RAM-JET COMBUSTOR

Run	Slurry injector size	Over-all equivalence ratio	Combustion efficiency, percent	Inlet-air -				Fuel weight flow, lb/hr				Boron in total fuel, percent	
				Weight flow, lb/hr	Pressure, in. Hg abs	Temperature, °F	Velocity, ft/sec	Slurry	Engine JP-4	Pre-heater JP-4	Pilot gasoline		
Configuration E													
16	0.188	0.254	70.0	43,300	30.0	570	221	850	0	82	60	48.3	
		.337	74.0	43,100	30.0	580	223	1,200	↓	↓	17	49.4	
		.445	68.1	43,000	30.0	580	222	1,590	↓	↓	12	51.4	
		.561	63.8	43,000	30.0	580	222	2,010	↓	↓	12	51.5	
		.704	55.4	43,400	31.0	570	215	2,490	↓	↓	60	50.6	
17	0.188	0.358	70.7	48,000	30.3	553	240	811	482	0	42	30.9	
		.447	72.0	48,200	29.8	544	242	1,180	482	↓	↓	35.2	
		.539	71.8	48,300	30.3	540	238	1,560	490	↓	↓	37.9	
		.632	66.1	48,500	30.5	530	235	1,960	490	↓	↓	40.0	
18	0.188	0.349	55.8	46,700	29.3	554	241	798	400	118	35	32.4	
		.438	64.4	47,400	30.2	550	236	1,160	↓	↓	↓	36.4	
		.538	68.6	46,900	30.3	554	234	1,530	↓	↓	↓	39.0	
		.645	66.5	46,500	30.2	560	234	1,920	↓	↓	↓	40.8	
		.779	61.0	46,200	30.2	568	234	2,420	↓	↓	↓	42.4	
		.191	75.2	46,700	29.5	587	242	0	535	↓	↓	0	
		.355	86.8	45,900	30.3	588	236	0	1,030	↓	↓	0	
		.556	84.0	45,600	30.3	590	235	0	1,620	↓	↓	33	0
19	0.188	0.357	72.3	44,500	29.5	576	233	798	400	95	12	33.0	
		.459	67.3	44,200	30.0	582	229	1,160	↓	↓	↓	36.9	
		.561	60.0	44,100	30.0	588	230	1,540	↓	↓	↓	39.5	
		.667	51.8	44,100	30.0	590	230	1,920	↓	↓	↓	41.2	
		.801	48.0	44,300	30.0	588	231	2,420	↓	↓	↓	42.7	
		.209	90.7	44,300	30.0	561	226	0	575	↓	↓	32	0
		.310	87.9	45,800	30.0	562	232	↓	900	↓	↓	32	↓
		.394	83.0	45,500	30.0	566	231	↓	1,160	↓	↓	19	↓
		.429	82.1	45,600	30.0	564	231	↓	1,260	↓	↓	31	↓
Configuration F													
20	0.250	0.220	26.4	44,800	31.0	570	222	704	0	415	16	48.9	
		.342	45.2	45,300	27.3	570	255	1,070	↓	↓	51	47.7	
		.477	58.6	45,300	30.5	573	229	1,510	↓	↓	62	48.0	
		.600	65.5	45,300	30.0	572	233	1,920	↓	↓	↓	48.4	
		.747	67.2	44,900	30.5	572	226	2,390	↓	↓	↓	48.4	
		.873	64.5	45,000	30.0	573	231	2,810	↓	↓	↓	48.9	
		1.023	60.0	44,900	30.0	573	231	3,300	↓	↓	↓	49.1	
21	0.188	0.572	81.6	44,800	30.0	572	230	753	830	415	62	22.9	
		.838	82.3	44,800	30.3	575	230	1,670	↓	↓	31	33.0	
		1.210	78.8	42,200	30.0	584	219	2,650	↓	↓	10	38.0	
22	0.188	0.436	44.1	46,700	30.3	560	234	746	540	415	62	27.7	
		.605	61.7	45,800	30.1	563	232	1,290	↓	↓	↓	34.1	
		.805	73.1	45,700	30.4	565	230	1,950	↓	↓	↓	38.2	
		1.038	71.7	44,500	30.2	570	226	2,640	↓	↓	↓	40.8	
23	None	0.287	65.1	44,500	30.0	567	227	0	680	415	62	0	
		.324	86.4	44,500	29.0	550	230	↓	780	↓	↓	60	
		.395	95.6	45,700	30.0	565	232	↓	990	↓	↓	62	
		.438	89.4	44,500	30.0	550	223	↓	1,100	↓	↓	35	
		.543	96.3	44,700	30.0	567	228	↓	1,350	↓	↓	62	

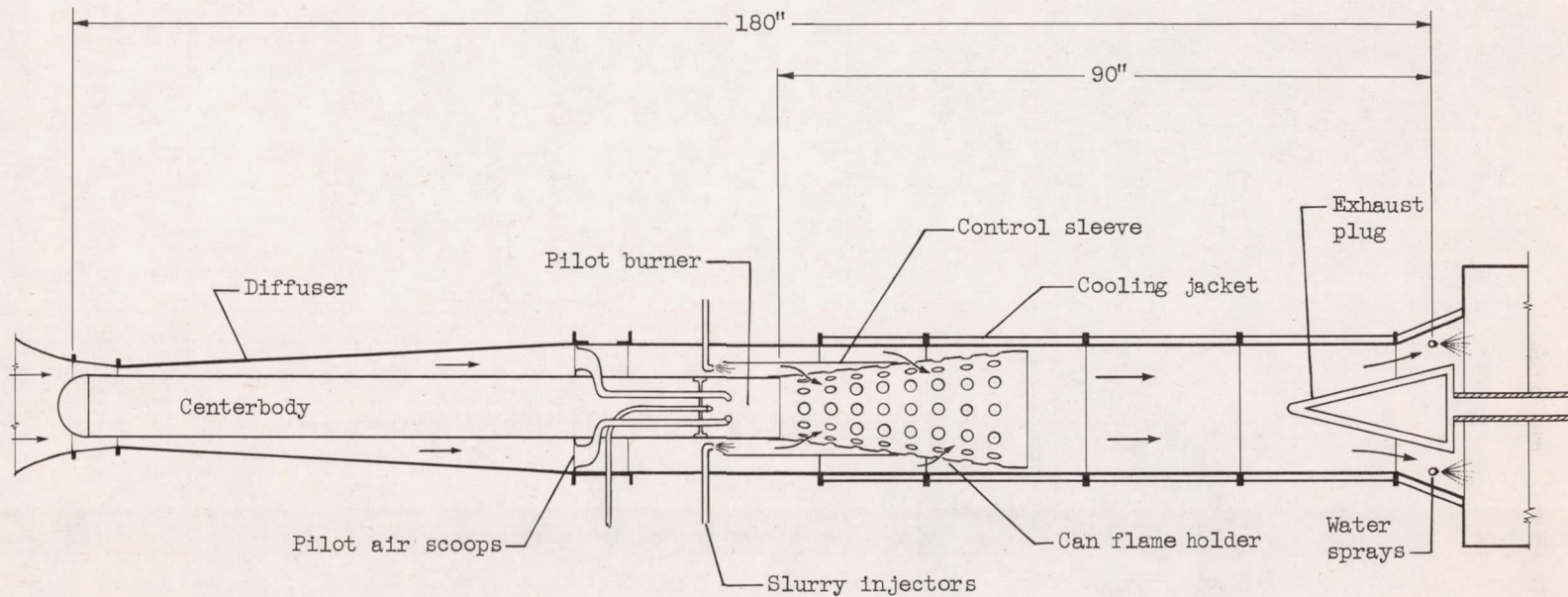

CD-4139

Figure 1. - Sketch of 16-inch ram-jet engine showing position of slurry injectors, control sleeve, pilot flame holder, and exhaust plug.

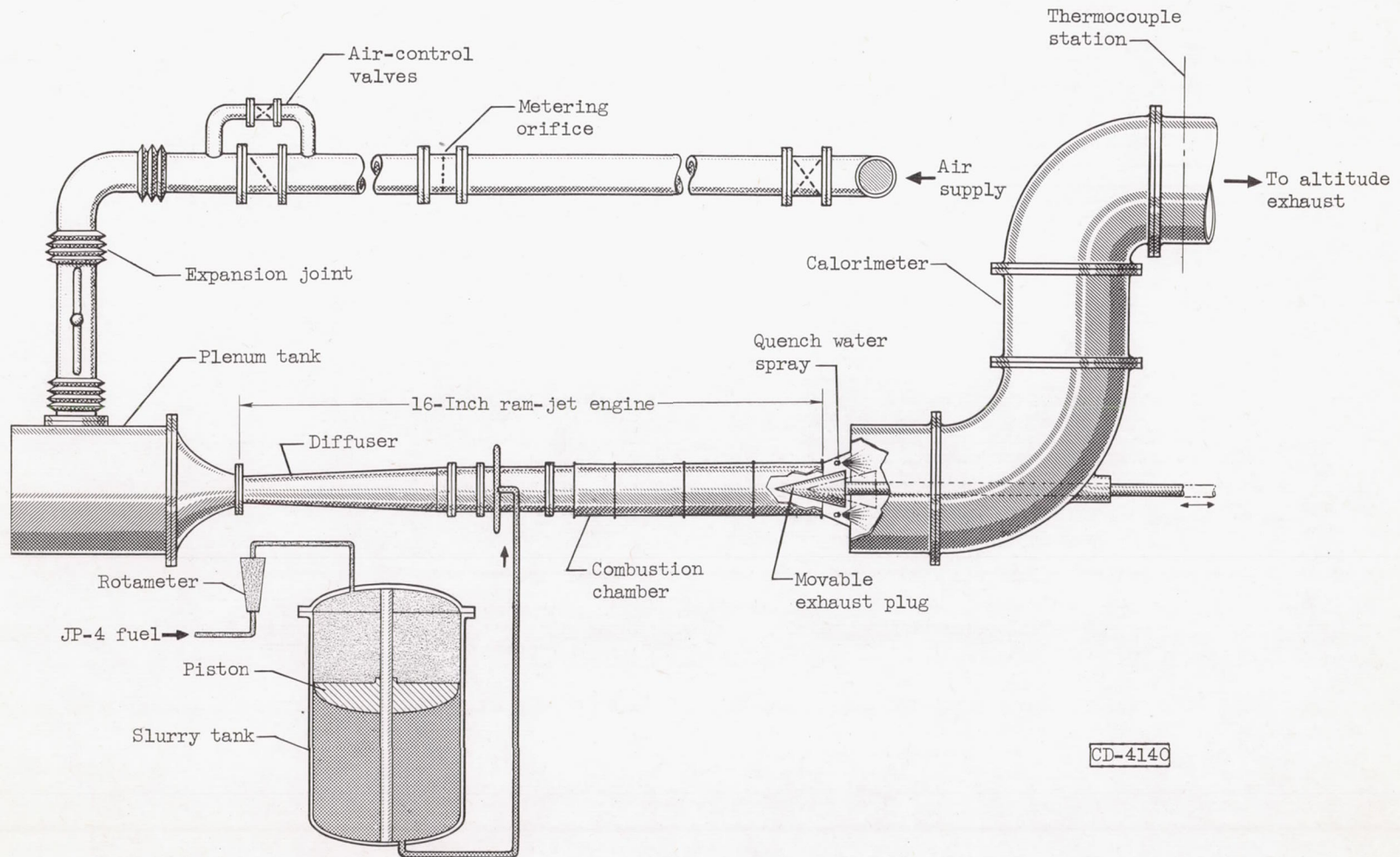
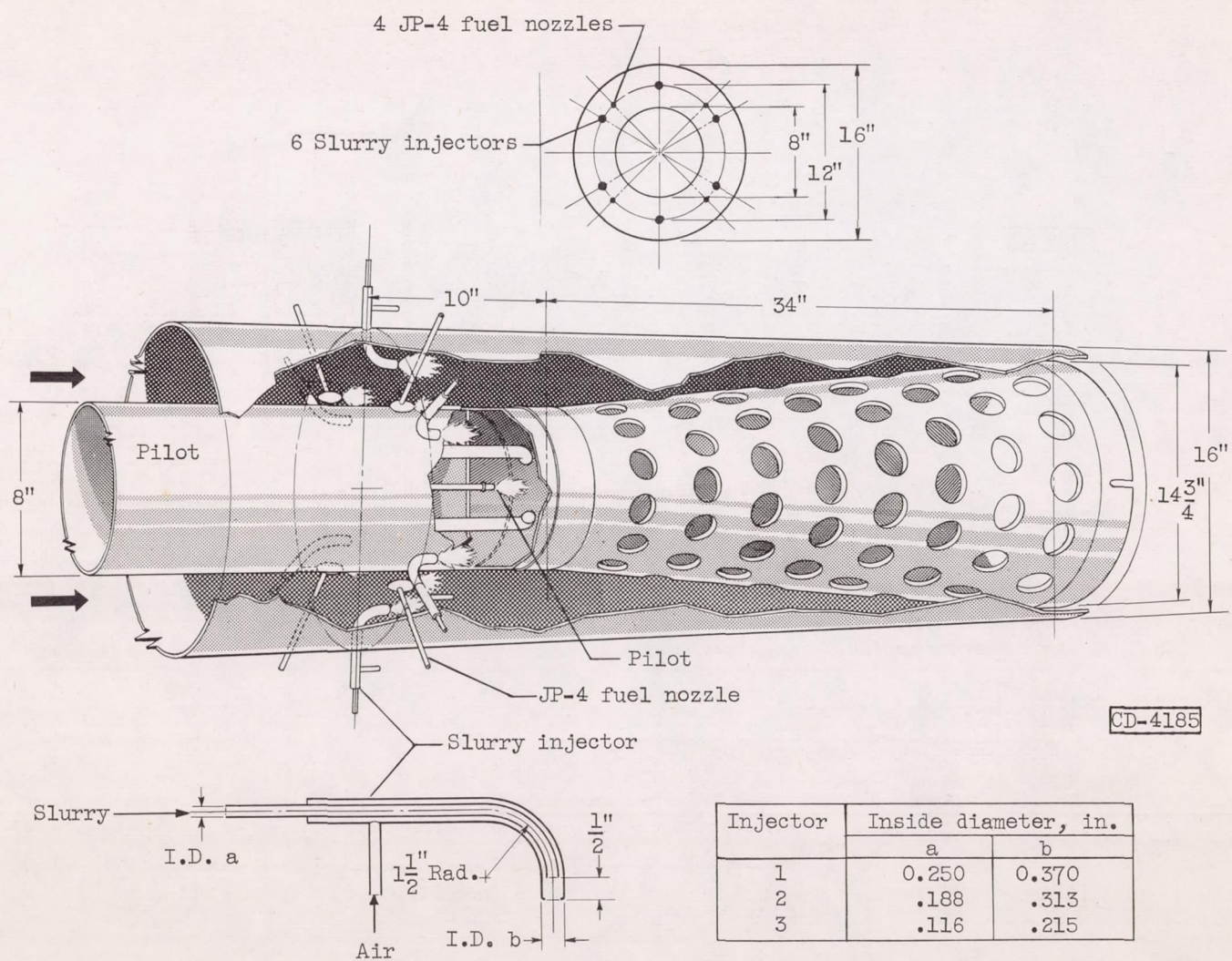

Figure 2. - Installation of 16-inch ram-jet engine.



CD-4185

(a) Configuration A.

Figure 3. - Fuel-injector and flame holder configurations.

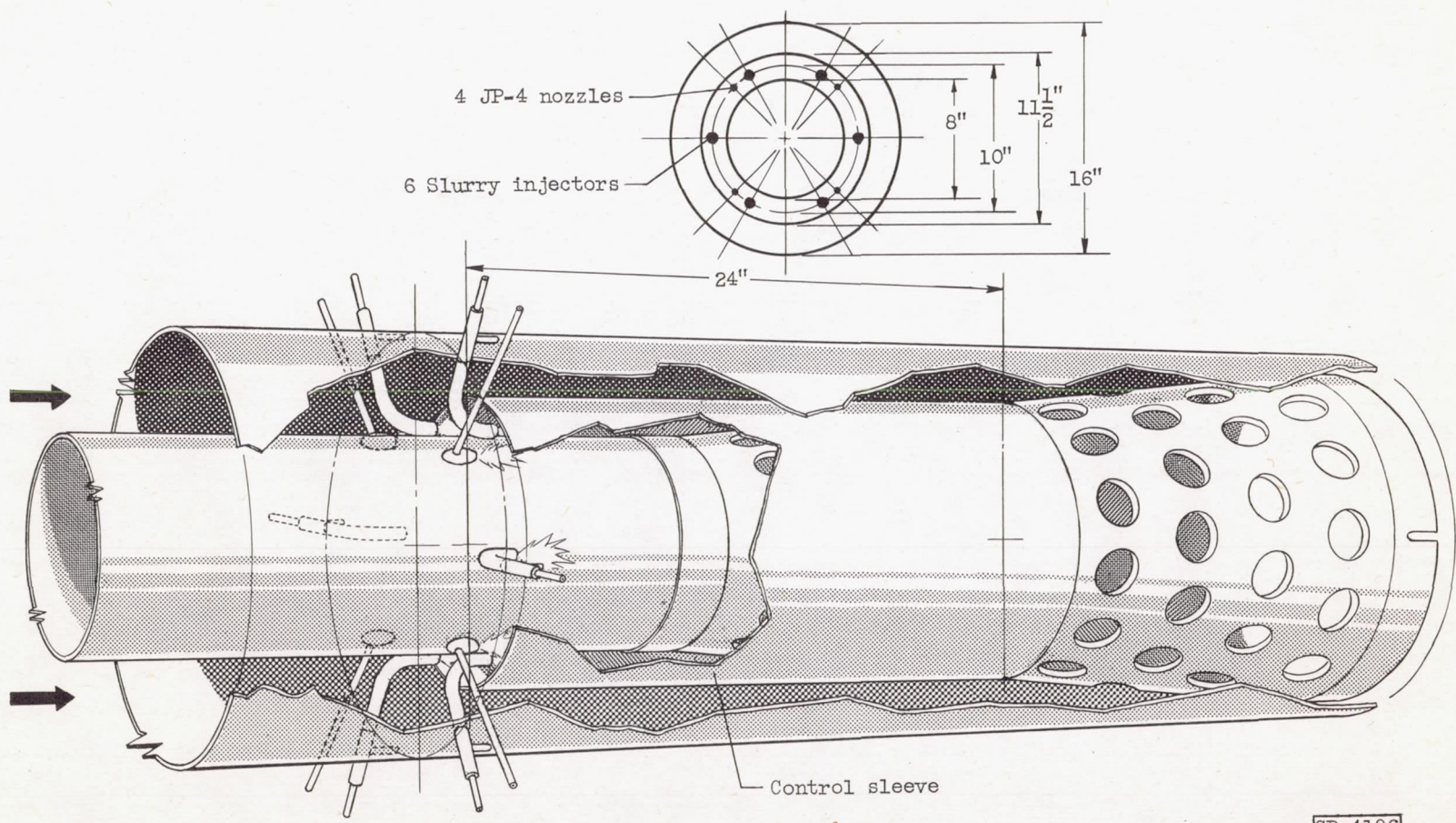

CD-4186

(b) Configuration B.

Figure 3. - Continued. Fuel-injector and flame holder configurations.

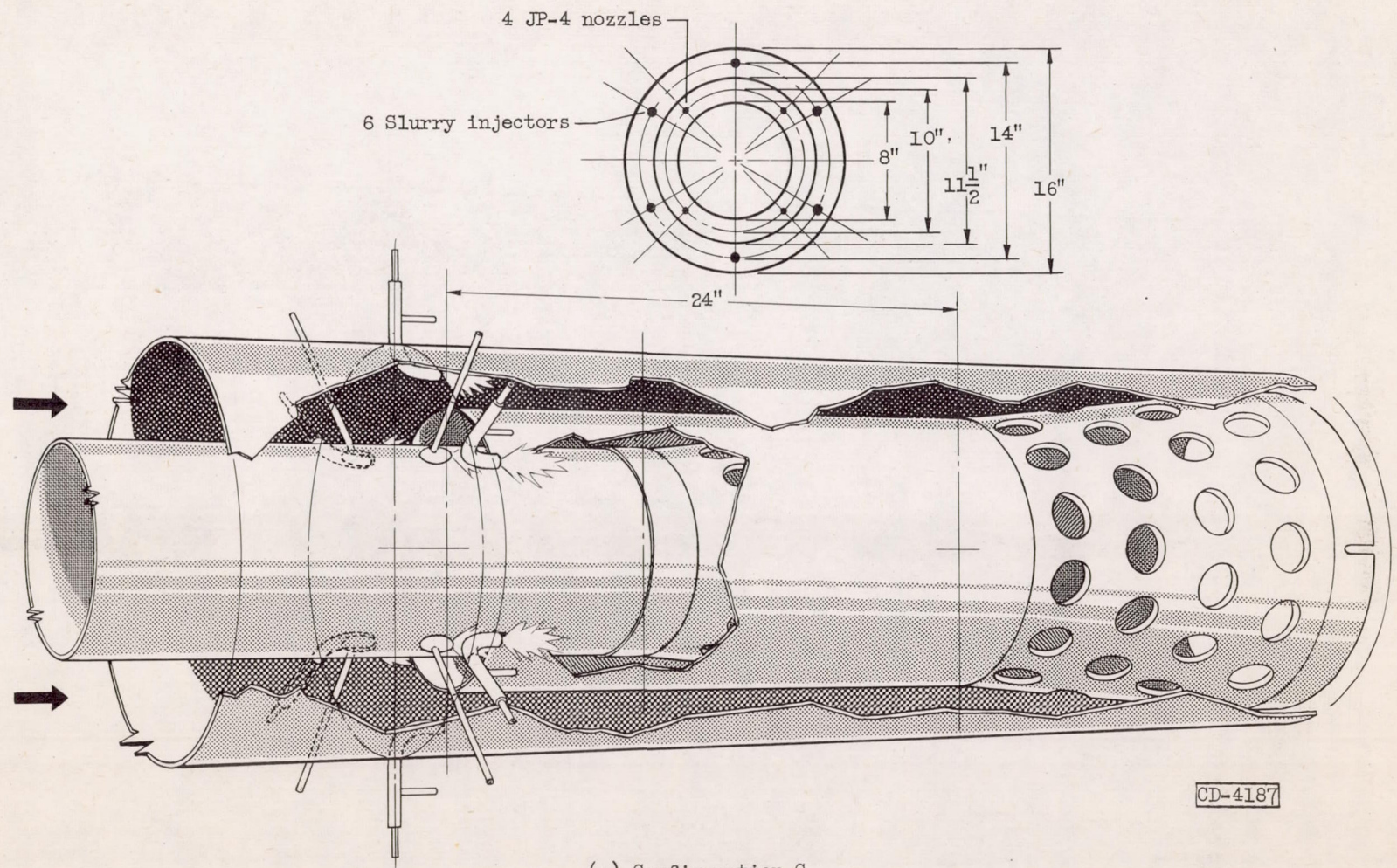

(c) Configuration C.

Figure 3. - Continued. Fuel-injector and flame holder configurations.

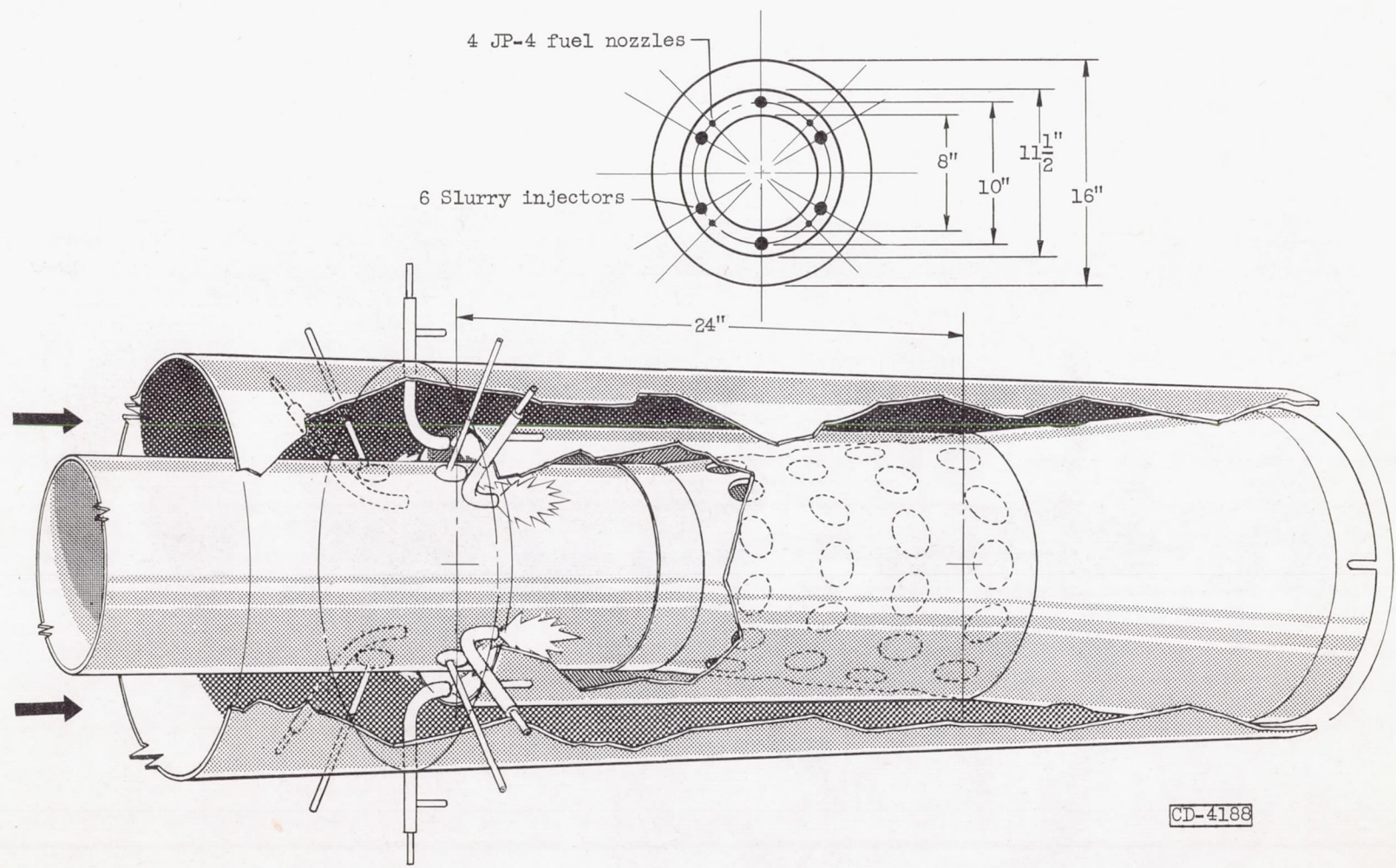

(d) Configuration D.

Figure 3. - Continued. Fuel-injector and flame holder configurations.

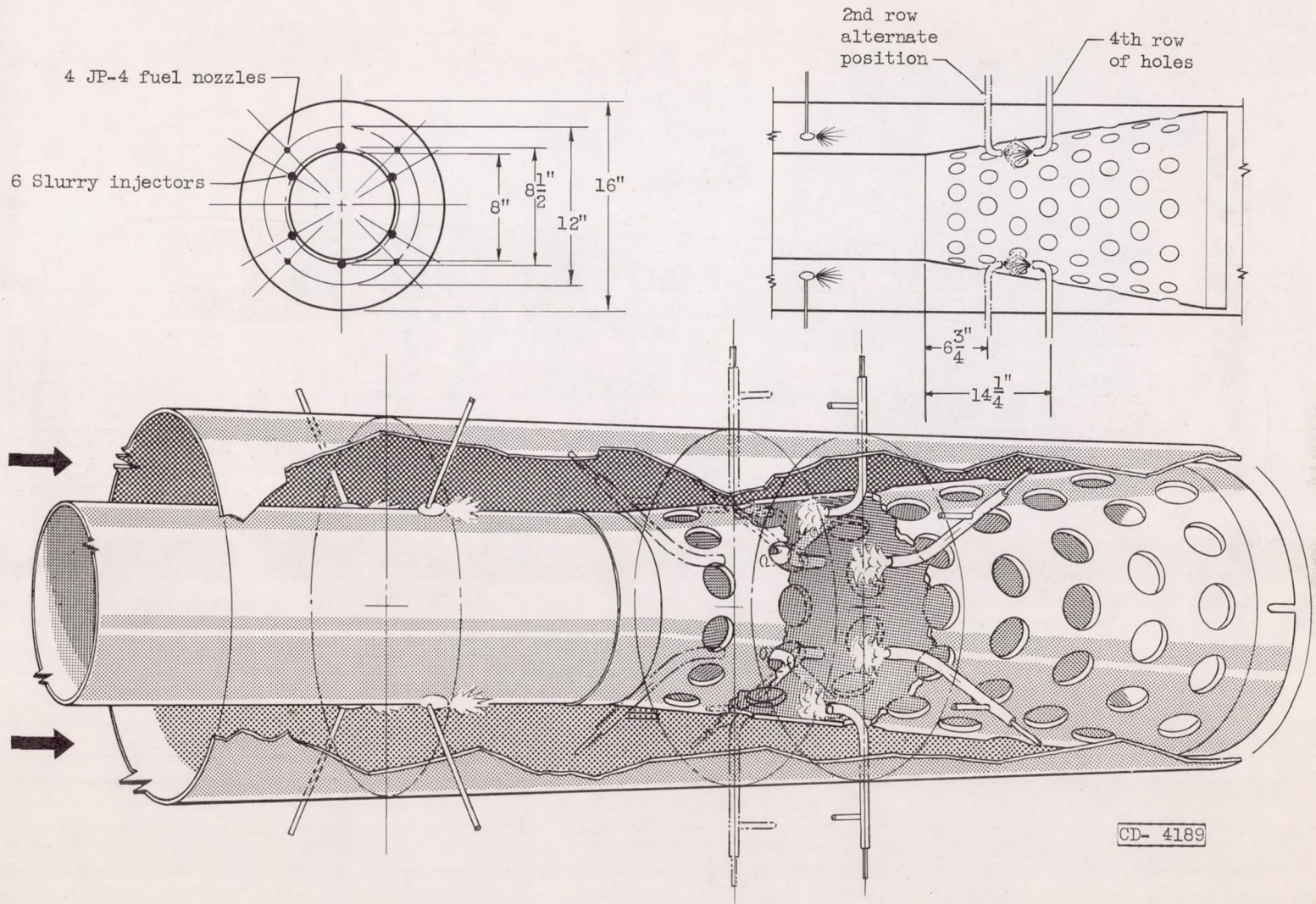

(e) Configuration E.

Figure 3. - Continued. Fuel-injector and flame holder configurations.

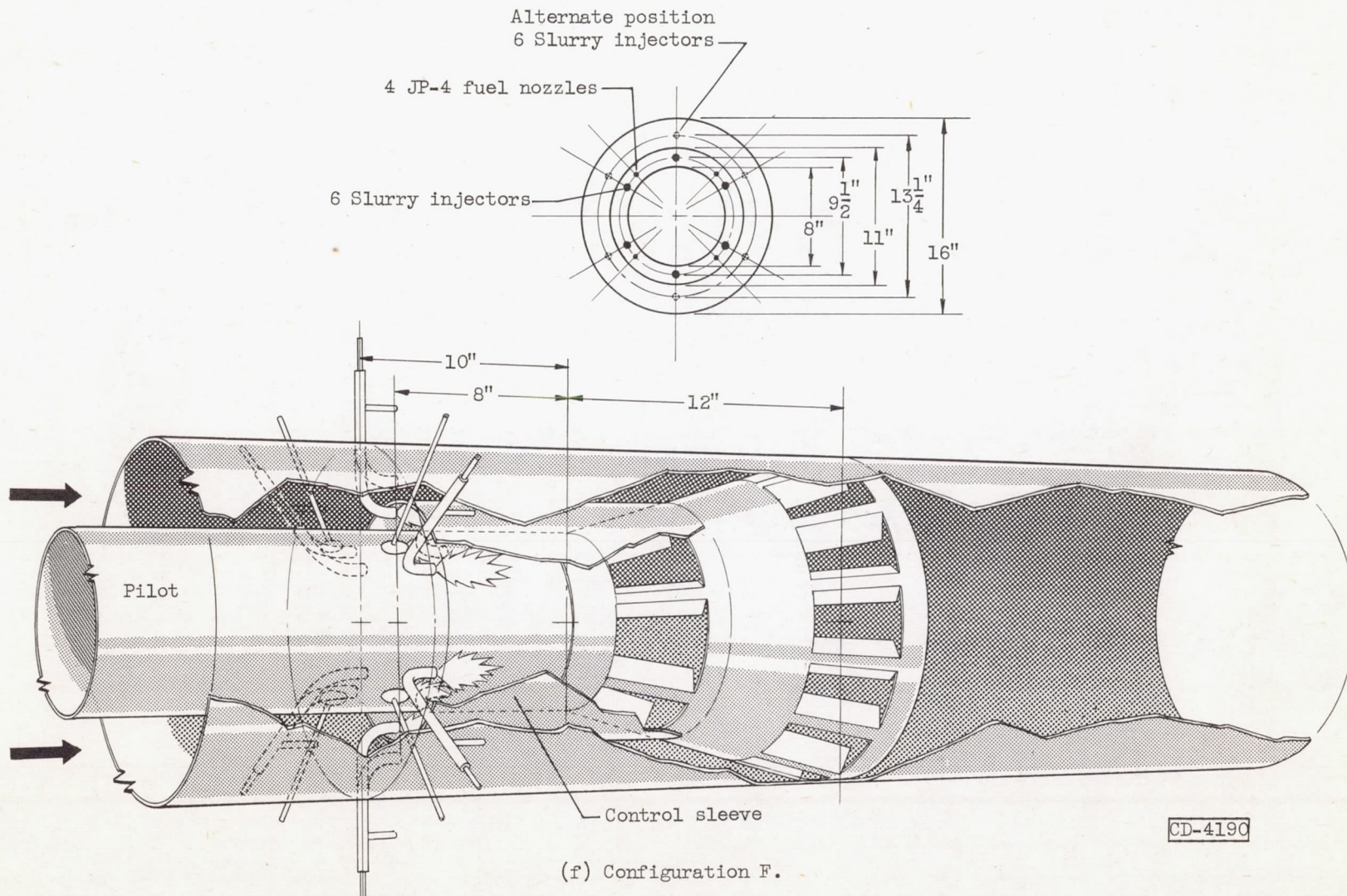
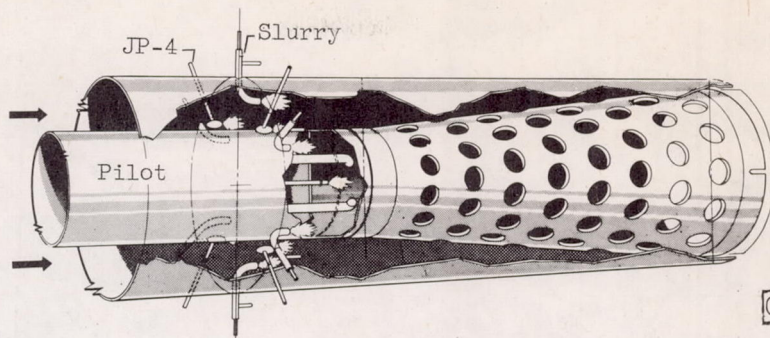
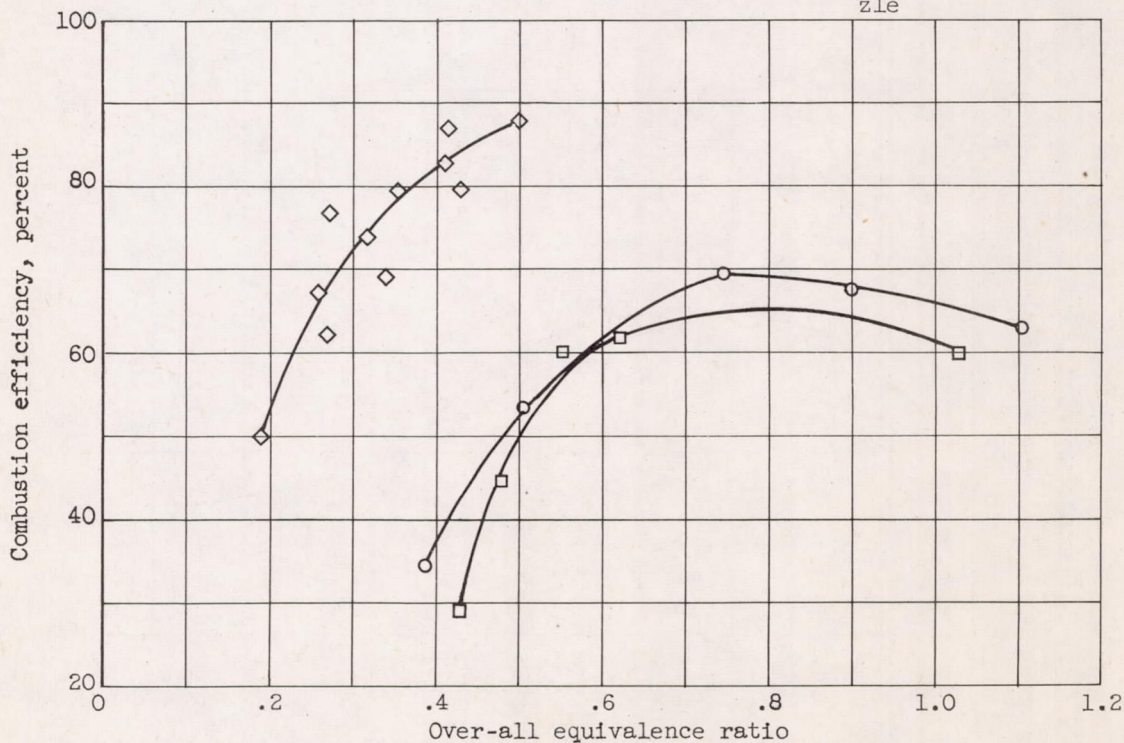

Figure 3. - Concluded. Fuel-injector and flame holder configurations.



Run	Injector direction	Inlet-air temperature, °F	Inlet-air velocity, ft/sec	Inlet-air pressure, in. Hg abs	Injector I.D., in.	Slurry composition
○ 1	Costream	560-575	181-221	32.0-39.0	0.188	65-Percent boron in n-heptane
□ 2	Contra-stream	578-583	231-282	29.0-29.5	.116	50-Percent boron in JP-4
◇ 3	Costream	575 (av.)	235 (av.)	30.0 (av.)	Spray nozzle	JP-4 alone



(a) Configuration A. Comparison of performance of boron slurries and JP-4 fuel.

Figure 4. - Performance of combustor configurations.

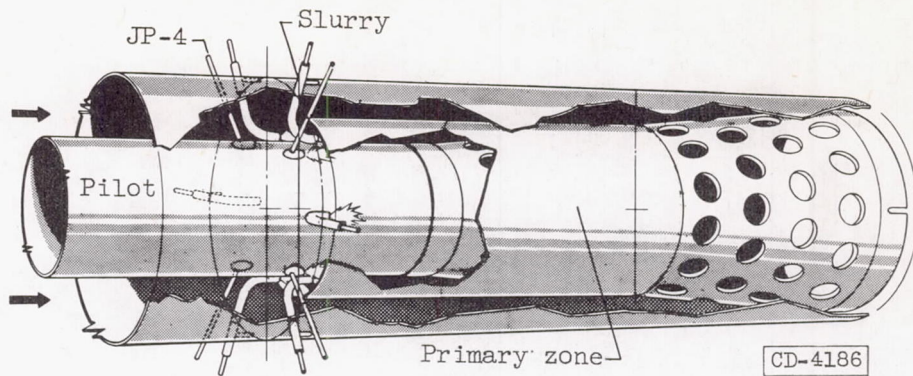

	Run	Inlet-air temperature, $^{\circ}\text{F}$	Inlet-air velocity, ft/sec	Inlet-air pressure, in. Hg abs	Injector I.D., in.	Slurry composition	Nominal boron purity, percent
○	4	570	206-237	29.8-34.3	0.250	50- Percent boron in JP-4	90
□	5	590-595	237-260	30.0-30.2	.116		90
◇	6	587-590	197-230	20.0-22.2	.116		90
△	7	580	228	29.8	.116		96
▽	8	575 (av.)	235 (av.)	30.0 (av.)	Spray nozzle	JP-4 alone	

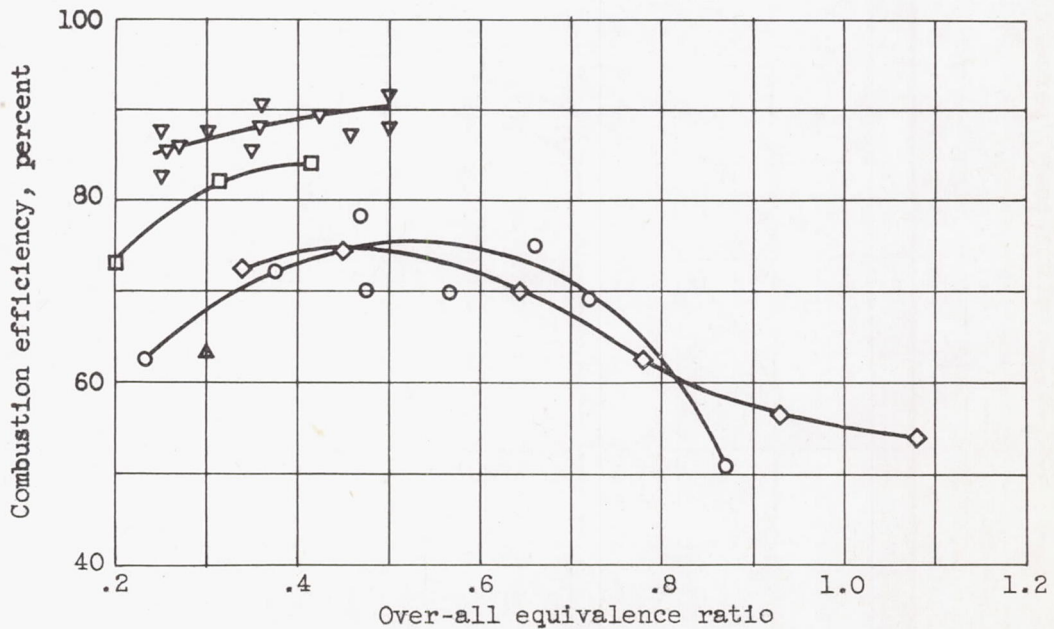

(b) Configuration B. Slurry injected costream into primary zone; combustion air vitiated.

Figure 4. - Continued. Performance of combustor configurations.

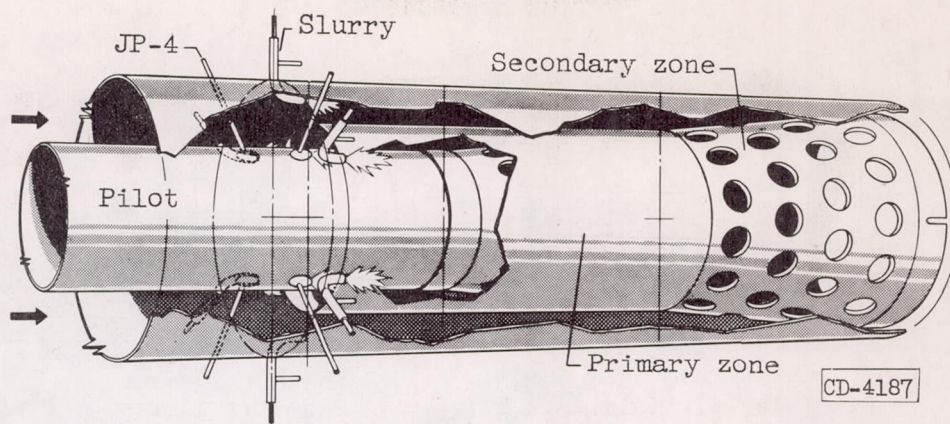

Run	Inlet-air temperature, $^{\circ}\text{F}$	Inlet-air velocity, ft/sec	Inlet-air pressure, in. Hg abs	Boron, percent of total fuel	Jp-4 addition to primary zone, lb/hr
-----	---	----------------------------	--------------------------------	------------------------------	--------------------------------------

○	9	516-530	174-207	34.2-39.8	32-50	830
□	10	490-530	185-211	33.2-38.6	38-55	535
◇	11	480-594	232-254	30.0-30.6	30-48	830

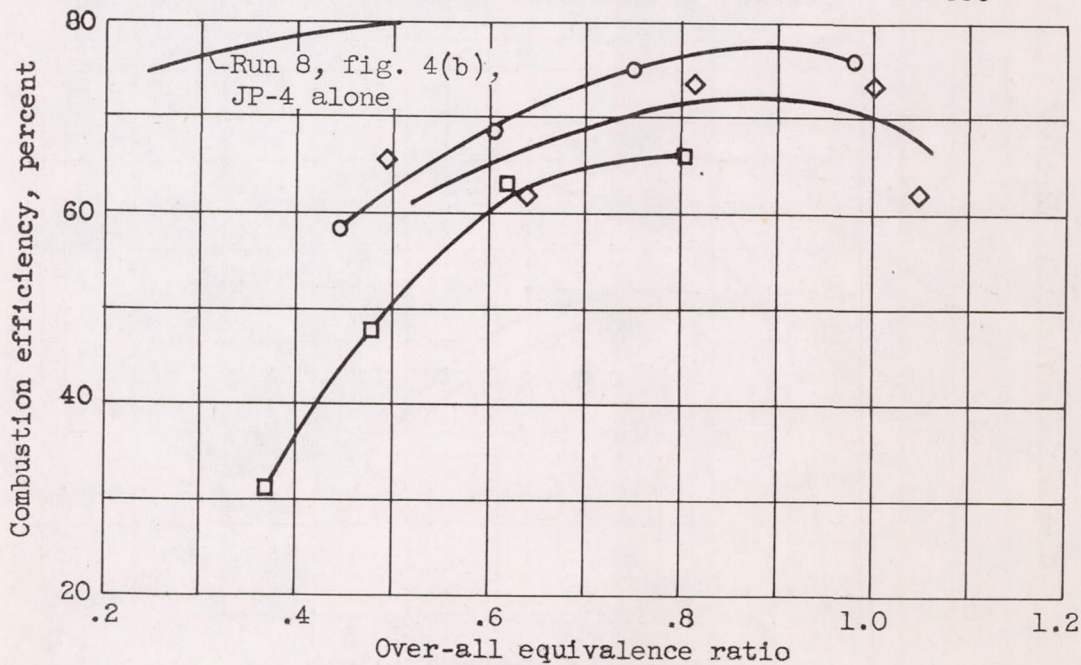

(c) Configuration C. 65-Percent boron in n-heptane injected costream into secondary zone through 0.188-inch injectors.

Figure 4. - Continued. Performance of combustor configurations.

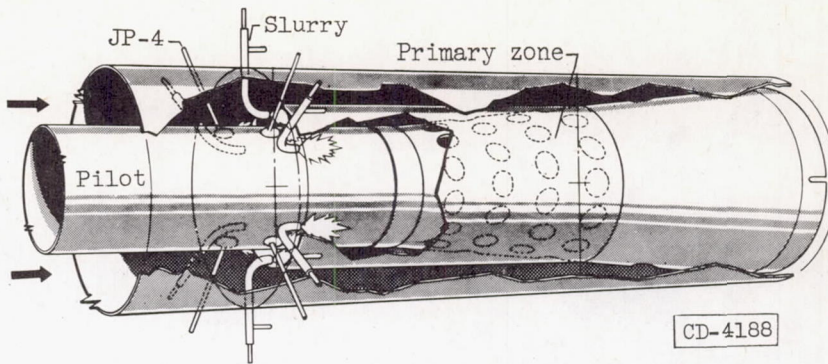

Run Inlet-air Inlet-air Inlet-air Injector
 tempera- velocity, pressure, I.D.,
 ture, ft/sec in. Hg abs in.
 ϕ_F

○	12	560-565	222-254	28.5-32.5	0.250
□	13	568-570	234-238	29.8-30.3	.188
◇	14	556	195	30.2	.188
△	15	562-569	231-239	30.1-31.0	Spray nozzle

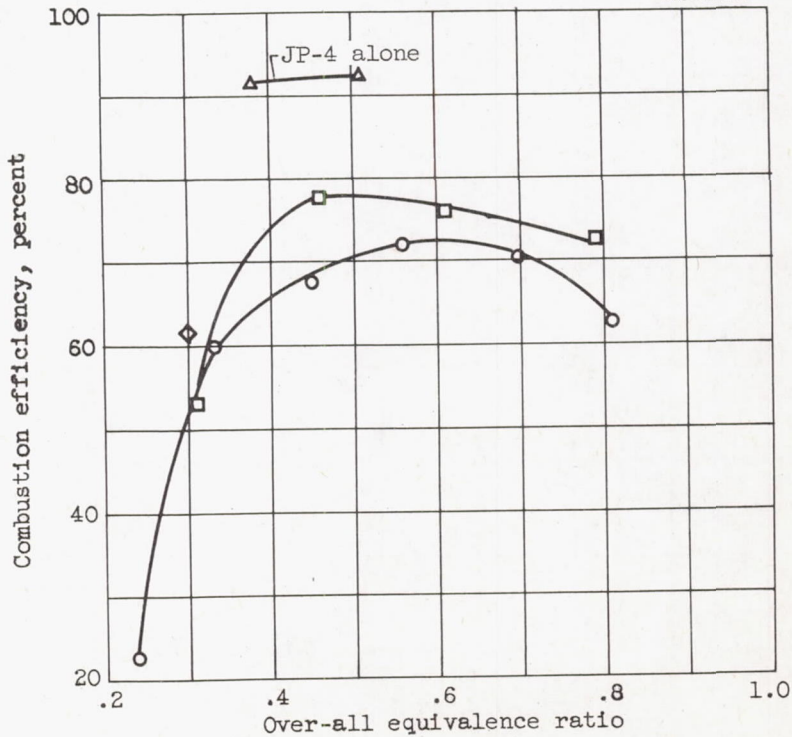

(d) Configuration D. 50-Percent boron in JP-4 injected costream into primary zone.

Figure 4. - Continued. Performance of combustor configurations.

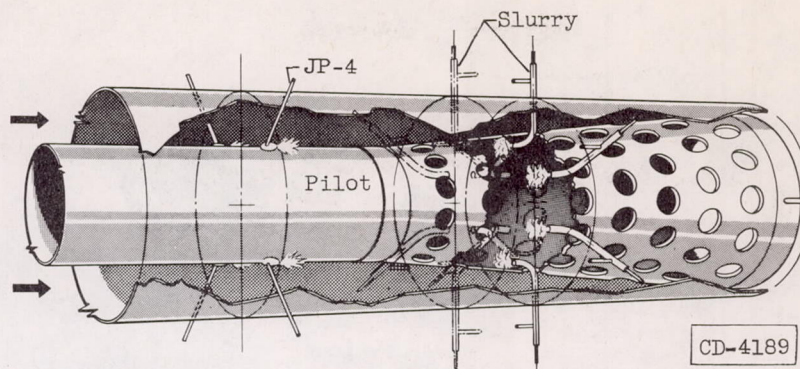

Run	Inlet-air temperature, °F	Inlet-air velocity, ft/sec	Inlet-air pressure, in. Hg abs	Boron, percent of total fuel	JP-4 addition upstream of flame holder, lb/hr	Injector position, hole row	Injector direction
○ 16	570-580	215-223	30.0-31.0	50	None	4 th	Contra-stream
□ 17	530-553	235-242	29.8-30.5	31-40	482-490	4 th	4 Contra-stream, 2 costream
◇ 18	550-590	234-242	29.3-30.3	32-42	400	2 nd	Costream
▲ 19	561-590	226-233	29.5-30.0	33-43	400	4 th	Contra-stream

Tailed symbols denote JP-4 alone through slurry injectors

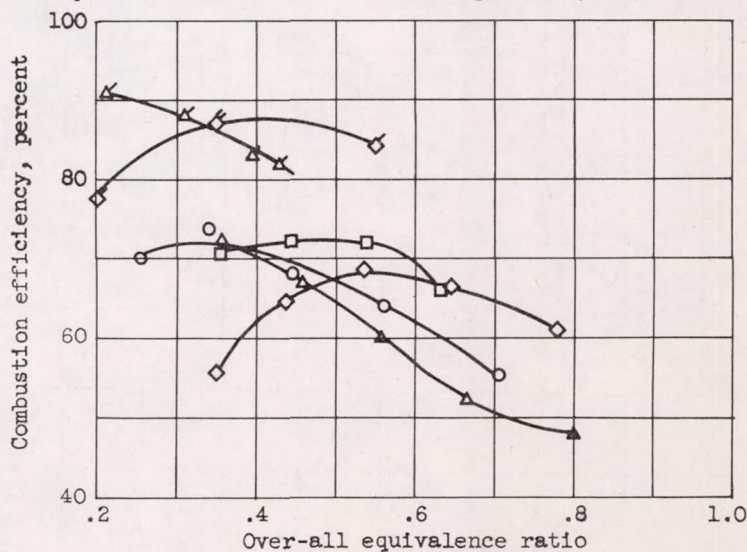

(e) Configuration E. 50-Percent boron in JP-4 injected internally through 0.188-inch injectors.

Figure 4. - Continued. Performance of combustor configurations.

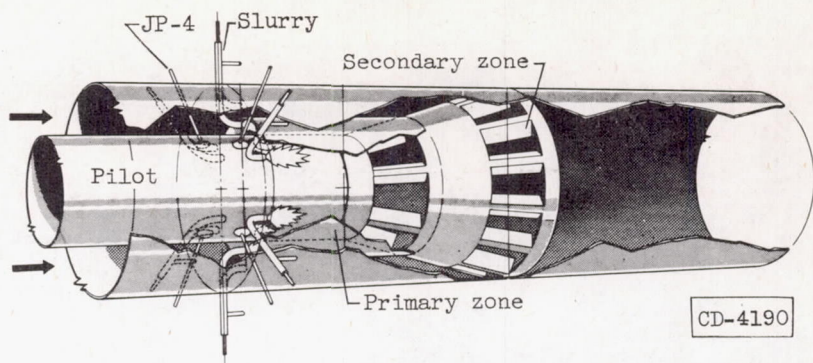

Run	Inlet-air temperature, °F	Inlet-air velocity, ft/sec	Inlet-air pressure, in. Hg abs	Boron, percent of total fuel zone,	JP-4 added to primary zone, lb/hr	Injector location
○ 20	570-573	222-255	27.3-31.0	49	None	Primary zone
□ 21	572-584	219-230	30.0-30.3	23-38	830	Secondary zone
◇ 22	560-570	226-234	30.1-30.4	28-41	540	Secondary zone
△ 23	550-567	223-232	29.0-30.0	None	None	Primary zone

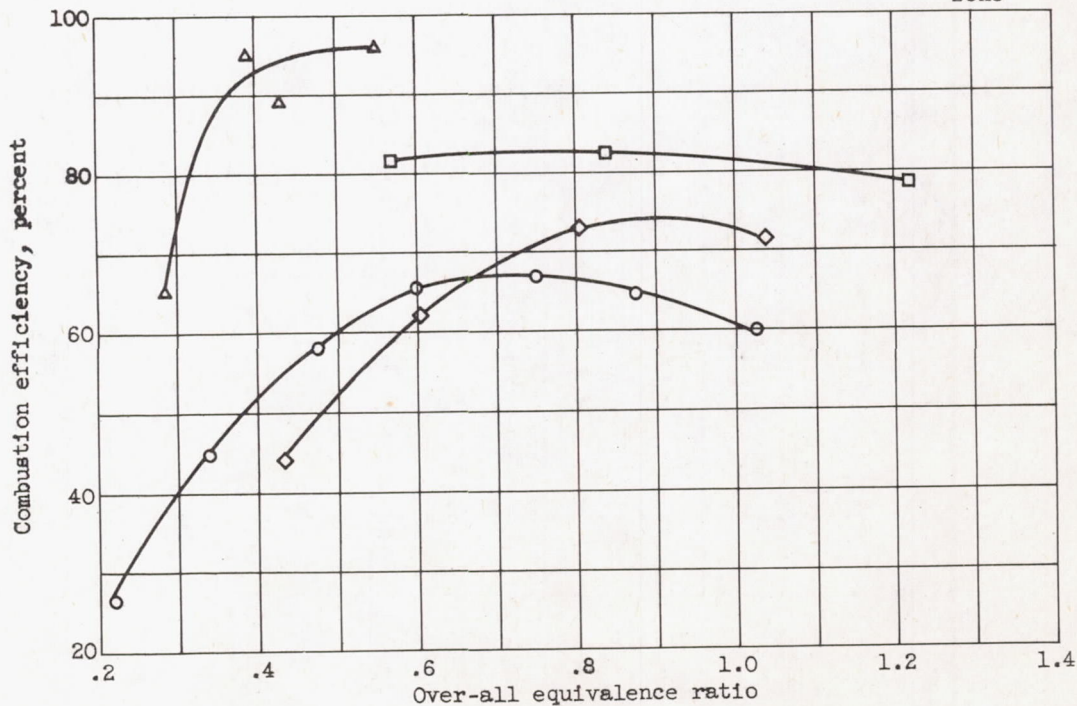

(f) Configuration F. 50-Percent boron in JP-4 injected costream; combustion air vitiated.

Figure 4. - Concluded. Performance of combustor configurations.

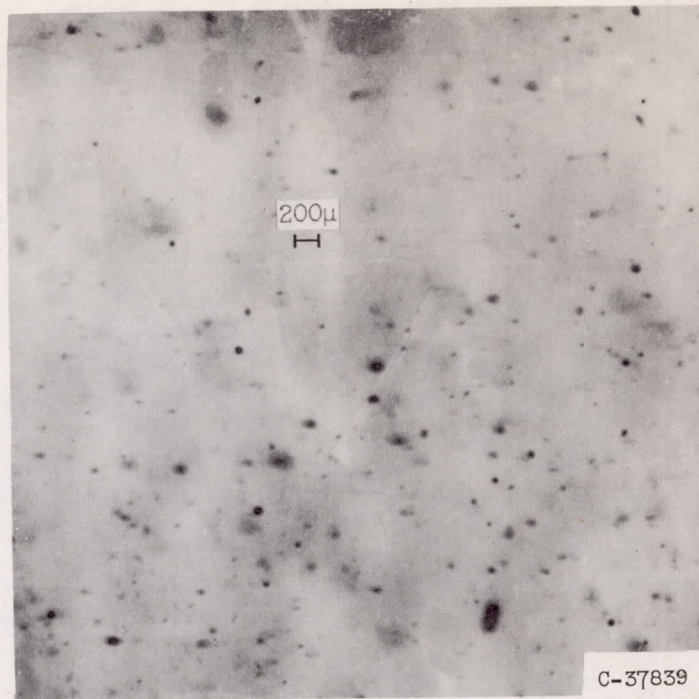

(a) Simulated engine conditions: velocity, 200 feet per second; temperature, 575° F; pressure, 1 atmosphere. Window 7 inches downstream of costream injector.

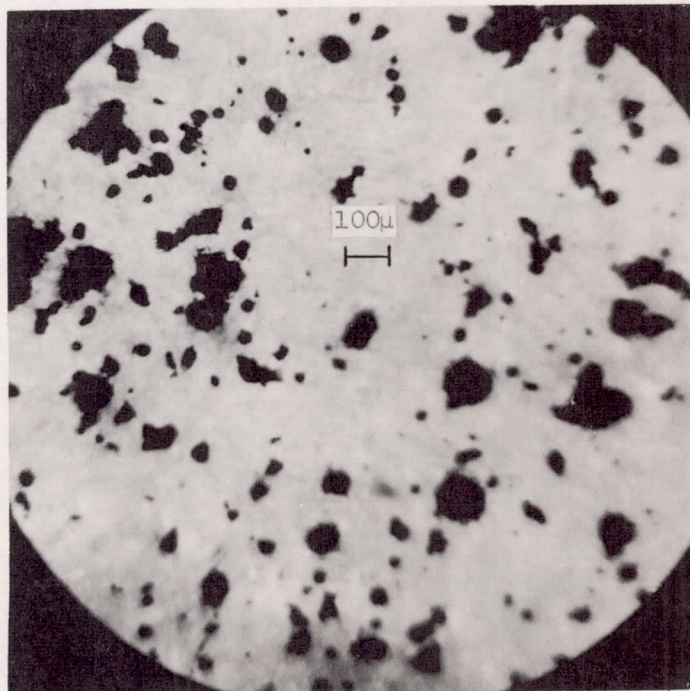

(b) Open-air sample taken 18 inches from injector.

Figure 5. - Photomicrographs of boron slurry spray.

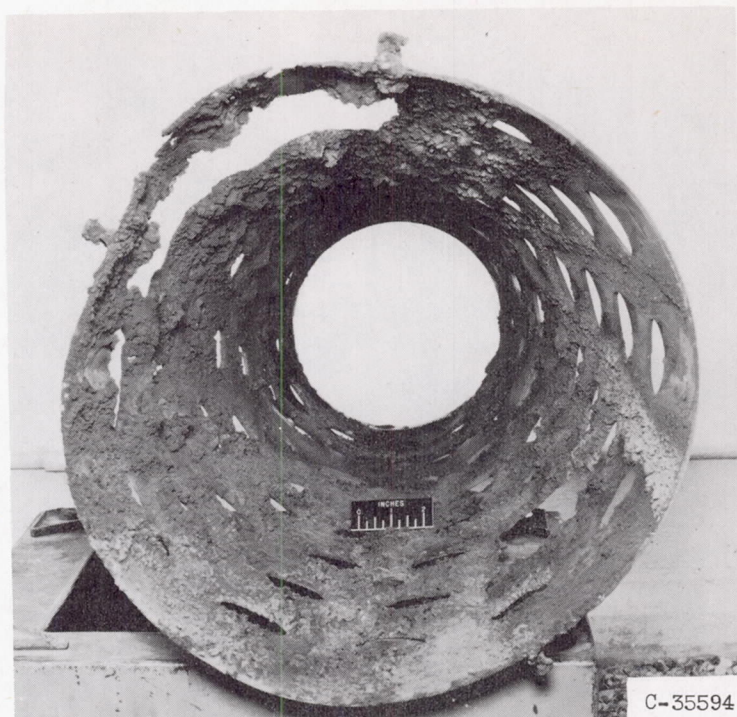

(a) Run 4; slurry injected upstream of flame holder.

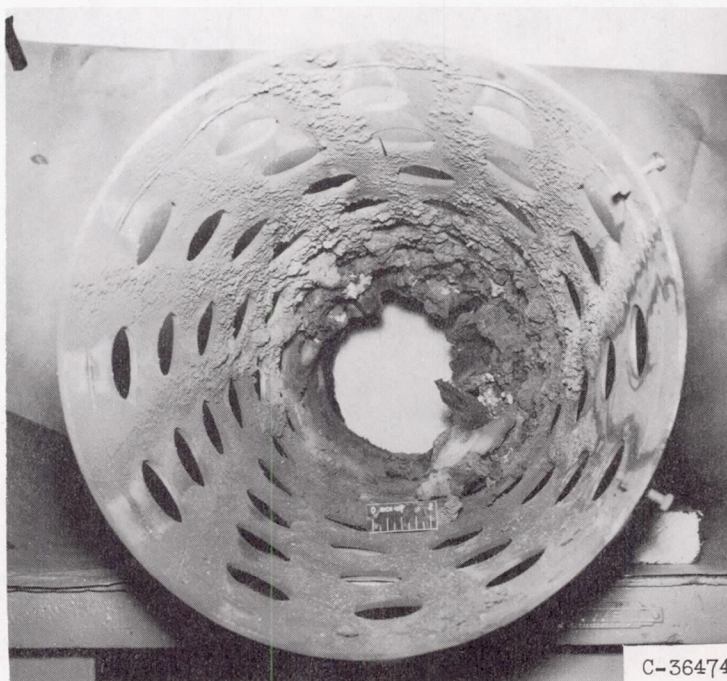

(b) Run 17; slurry injected internally; end view.

Figure 6. - Photographs of flame holders after boron slurry runs.

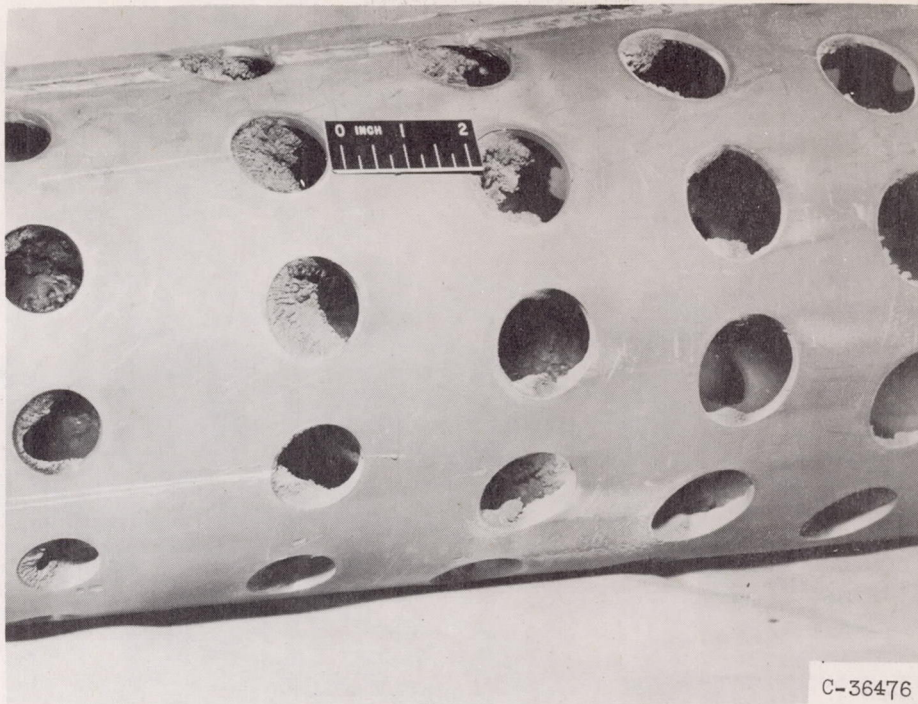

(c) Run 17; slurry injected internally; side view.

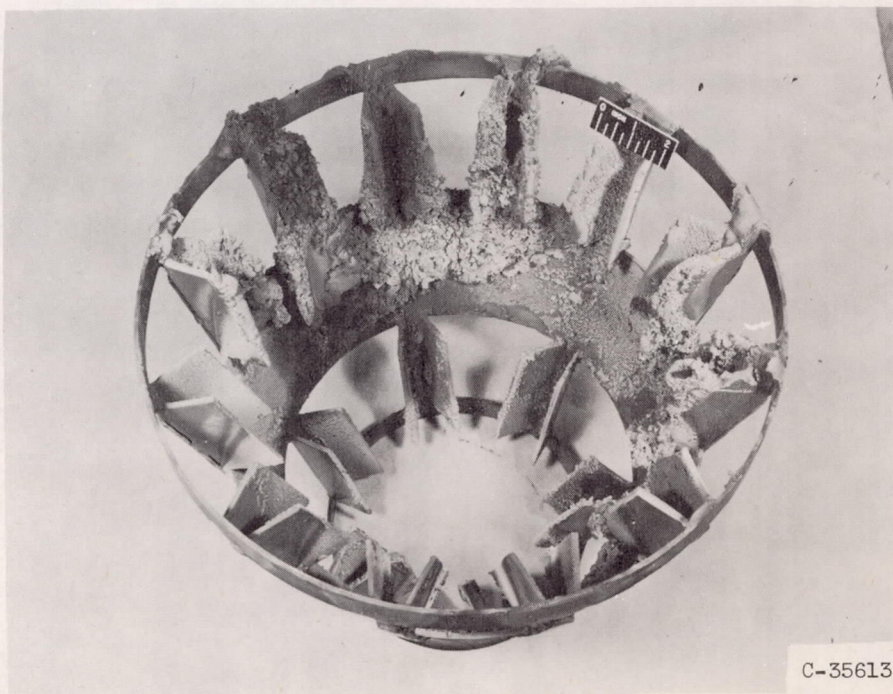

(d) Injector plugging; run similar to run 22; slurry injected upstream of flame holder.

Figure 6. - Concluded. Photographs of flame holders after boron slurry runs.