

RESEARCH MEMORANDUM

FLIGHT TEST OF A RADIAL-BURNING SOLID-FUEL RAM JET

By Walter A. Bartlett, Jr., and H. Rudolph Dettwyler

Langley Aeronautical Laboratory
Langley Field, Va.

NATIONAL ADVISORY COMMITTEE
FOR AERONAUTICS

WASHINGTON
December 10, 1952
Declassified March 18, 1960

NATIONAL ADVISORY COMMITTEE FOR AERONAUTICS

RESEARCH MEMORANDUM

FLIGHT TEST OF A RADIAL-BURNING SOLID-FUEL RAM JET

By Walter A. Bartlett, Jr., and H. Rudolph Dettwyler

SUMMARY

A flight investigation of a rocket-launched ram-jet engine incorporating a radial-burning solid fuel was made. During the flight the model accelerated from a Mach number of 1.95 and an altitude of 4,200 feet to a Mach number of 2.73 and an altitude of 14,600 feet in 5.5 seconds. In the boost period the fuel successfully withstood an acceleration of 25g. A maximum acceleration of 8.6g was obtained with the value of air specific impulse equal to 148 seconds. The maximum values of net and gross thrust coefficients were 0.49 and 0.61. An over-all fuel specific impulse of 412 seconds was calculated from the data. Combustion-chamber failure was experienced 9.3 seconds after take-off and prevented the ram jet from reaching a higher Mach number.

INTRODUCTION

A solid-fuel ram jet would satisfy the need for a medium-thrust, medium-range power plant and possess the simplicity and reliability of a solid-fuel rocket. The need for such a power plant is found when the high thrust of a solid-fuel rocket is not required. Although a solid-fuel ram jet does not give the high performance of a liquid-fuel ram jet, it should possess greater reliability in that it does not employ highly complex fuel-metering devices.

The available basic data on solid fuels indicated that a high-energy fuel could be obtained which would possess good performance characteristics suitable for application to a solid-fuel ram jet. Accordingly, the Pilotless Aircraft Research Division at the Langley Laboratory instituted an investigation to determine the performance of various types of solid-fuel charges in both preliminary ground and flight tests. The results of the ground tests (ref. 1) indicated that the fuels had reached the stage where flight testing was deemed advisable for further evaluation.

The results of the first NACA flight test of a solid-fuel ram jet, using a radial-burning magnesium-base fuel, are presented in this paper. The flight test was made at the Pilotless Aircraft Research Station at Wallops Island, Va. Other experiences with flights of a solid-fuel ram jet by another agency have been reported in reference 2.

SYMBOLS

p	static pressure, lb/sq in. abs
T	static temperature, °F abs
A	inlet capture area, sq ft
w	weight of model, lb
t	time measured from take-off, sec
S	combustion-chamber area, 0.231 sq ft
M	flight Mach number
q	free-stream dynamic pressure, lb/sq ft
g	acceleration of gravity, 32.2 ft/sec ²
a _L	absolute longitudinal acceleration, ft/sec ²
C _D	external drag coefficient, based on combustion-chamber area
C _{Tn}	net thrust coefficient, $\frac{a_L \frac{w}{g}}{qS}$
C _{Tg}	gross thrust coefficient, C _{Tn} + C _D
S _a	sonic air specific impulse, lb of jet thrust/lb of air/sec
∅M	ratio of jet impulse at any station to the jet impulse at a sonic station

- T_s stagnation temperature, or °F abs
- f/a fuel-air ratio, weight rate of fuel expenditure to weight rate
 of air flow
- H altitude, ft

APPARATUS AND METHODS

Flight model.- The model, incorporating a Mach number 2.13 design conical-shock inlet diffuser, is shown as a sketch and a photograph in figures 1(a) and 1(b). The inlet diffuser was attached to a 0.093-inch wall Inconel combustor shell upon which four fins, each with an area of 0.416 square foot were mounted. Two diametrically opposite circular-arc airfoils with a maximum thickness of 1/2 inch and a chord of 3 inches fastened the innerbody to the diffuser wall. The model was 67.75 inches in length with a $6\frac{1}{2}$ -inch-inside-diameter combustion chamber.

The area ratio of the combined supersonic and subsonic diffuser was 0.461, based on the area at the entrance lip and the combustion-chamber area. The contraction and expansion area ratios of the exit nozzle are 0.853 and 0.923, when referenced to the combustion-chamber area.

The ram jet was comprised of a cast-magnesium inlet diffuser, a sheet Inconel combustor, and a stainless-steel exit nozzle and fins. The empty model weight was 59.9 pounds.

Fuel.- The radial-burning magnesium-base solid-fuel charge was produced by the Continental Aviation and Engineering Corporation. A photograph of the charge is presented as figure 2, and a description of its manufacture is presented in reference 3. A preflight test of a similar type of fuel charge, with an 8-percent rubber-cement binder was reported in reference 1.

The composition of the flight charge was as follows:

Fuel:	
Magnesium, atomized, percent	82
Oxidizer:	
Sodium nitrate, percent	10
Binder:	
Rubber cement, percent	6
Stearic acid, percent	2

A preflight check of this flight-type charge, showed that the performance was essentially the same as that for a charge incorporating an 8-percent all rubber-cement binder. The fuel charge was $4\frac{1}{4}$ - inches inside diameter and $6\frac{1}{4}$ - inches outside diameter with a length of $21\frac{1}{4}$ inches. An annular ignitor ring made up of barium nitrate, atomized magnesium, and nitrocellulose cement was cemented to the upstream end of the fuel charge. Two 4-delay electric squibs imbedded in the black-powder mix on the face of the ignitor were fired for ignition. The fuel-charge weight was 16.31 pounds. The charge was cemented into a 0.047-inch wall steel liner having a weight of 6.28 pounds. This unit was attached to the ram jet at the inlet section-combustor shell juncture (fig. 1(a)) and held in place with machine screws. A steel retainer ring was firmly placed against the downstream end of the fuel charge and attached to the combustor shell.

Booster rocket and adapter.- A JATO, 3.5-DS-5,700 rocket motor was used to accelerate the ram jet to supersonic speed. A cast magnesium alloy coupling fastened to the rocket motor and fitted internally in the ram-jet exit nozzle attached the booster to the ram jet (fig. 3). This coupling was designed to block only 10 percent of the area through the ram-jet nozzle during the time of boost in case it was desired to ignite the ram-jet fuel in this period. Four fins, each with an area of $1\frac{1}{4}$ square feet, were mounted at the rear end of the rocket motor and provided stability of the combination during the boost period. A photograph of the ram jet and coupled booster in place on the launcher prior to firing is shown in figure 4.

Measurements.- The velocity of the model in flight was measured with a continuous-wave Doppler radar. The position of the model in space was determined with NACA modified SCR 584 tracking radar. The altitude of the model at any given time - obtained from SCR 584 data - is presented in figure 5. High-speed manually operated tracking cameras provided information on the behavior of the model in flight.

Upon completion of the flight test, a radiosonde balloon was released to obtain the pressure and temperature of the atmosphere as a function of altitude. The radiosonde balloon was tracked with SCR 584 radar to obtain wind velocity at altitude. Values of static pressure p and static temperature T computed from radiosonde data are presented in figure 6 as functions of altitude.

The variation of inlet capture area - used in determining the weight flow of air - with free-stream Mach number is presented in figure 7.

These data were determined for an inlet geometrically similar to the flight engine, both by the experimental method and the one-dimensional flow analysis that are described in reference 4.

FLIGHT TEST

The model, launched at an elevation angle of 60° , was boosted to $M = 2.0$, 2.85 seconds after take-off at which time separation occurred. Ignition of the fuel charge occurred after the model had decelerated to $M = 1.97$. The ram jet continued to decelerate to $M = 1.95$, until the thrust of the ram jet overcame its drag. The model then accelerated to a maximum velocity of 2960 feet per second ($M = 2.73$) 9.3 seconds after take-off, at which time it had reached an altitude of 14,600 feet. At this time, which was 2 seconds before predicted fuel burnout, the ram jet performed an abrupt maneuver with an attendant large deceleration. Study of the high-speed motion pictures indicated that a hole was burned through the combustor wall. This failure introduced a side force which would cause the model to describe this violent maneuver.

RESULTS AND DISCUSSION

The time history of ram-jet flight Mach number is presented in figure 8. These data were computed from velocities corrected for wind speeds at various altitudes. The Doppler velocity data were used in these calculations until the time of 7.8 seconds, when the signal disappeared. The SCR 584 velocity data were then used to the time of 9.3 seconds, when the model underwent a violent maneuver with attendant rapid deceleration when the combustor failed. Observation of figure 8 shows that a peak value of $M = 2.73$ was obtained at the time of 9.3 seconds. Combustion-chamber burn-through was previously experienced in ground tests of these solid-fuel charges (ref. 1) and also in flight tests of solid fuels reported in reference 2.

The longitudinal acceleration of the ram jet is presented in figure 9 as a function of flight time. These values were obtained by differentiation of a velocity-time curve with an added correction for the model gravitational component. Ram-jet thrust did not exceed the drag until 0.65 second after ignition, as shown by the negative acceleration that the model underwent to that time. The acceleration then steadily increased to a maximum acceleration of 8.6g at the time of 6.8 seconds. Observation of the flight motion pictures showed that burning pieces of fuel were ejected from the ram jet at approximately 5 and 7 seconds. It was observed that the larger portion of fuel was ejected at approximately 7 seconds. This would immediately lower the fuel-air ratio in the ram

jet, thus reducing the thrust, and could account for the sharp decrease in acceleration at the time of 7 seconds. At the time of combustor failure only 4g acceleration was obtained. The problem of fuel break-up was also experienced during the ground-test program reported in reference 1. It is significant to note that the fuel successfully withstood a maximum acceleration of 25g - before ignition - during the boost period.

The net thrust coefficient C_{T_n} of the ram-jet engine is presented in figure 10 as a function of Mach number. The net thrust used in these calculations was obtained from the longitudinal acceleration data (fig. 9) and the mass of the ram jet, with appropriate corrections for changing mass with fuel consumption. The portions of fuel discharged from the model at 5 and 7 seconds were neglected for the purpose of calculating performance. The fuel expenditure was determined by assuming a linear radial burning rate of $\frac{1}{8}$ inch per second, as predicted from free-jet test results of similar charges (ref. 1). The external drag coefficient C_D of the model was estimated using existing experimental fin drag in conjunction with theoretical friction and pressure drag data. This drag coefficient was used to present qualitative values of gross thrust coefficient C_{T_g} as shown in figure 10. Maximum values of C_{T_n} and C_{T_g} of 0.49 and 0.61, respectively, were realized at $M = 2.32$.

A time history of the air specific impulse parameter S_a delivered by the ram jet is presented in figure 11. The values of S_a , at the sonic section of the exit nozzle, were obtained by adding the momentum of the air entering the ram jet to the gross thrust, and dividing this quantity by the weight flow of air and the thrust function ϕM (ref. 5). It should be noted at this time, that a 10-percent error in estimated C_D reflects a maximum error of only 1 percent in S_a for this data. Included on this figure are the stagnation temperatures T_s . A maximum value of $S_a = 148$ seconds at $T_s = 1050^\circ$ F absolute was obtained at $t = 6.9$ seconds. The output of S_a steadily decreased after this time to a value of 135 seconds ($T_s = 1210^\circ$ F abs) at the time of 9.3 seconds when combustor-shell failure occurred.

Calculated values of fuel-air ratio f/a at each instant during the flight are presented in figure 12. In order to obtain these values of f/a it was assumed that the combustion and impulse efficiencies obtained in this flight test were equal to those presented in reference 1. This assumption would allow the application of S_a values from figure 11 to the S_a against f/a correlation presented for similar fuels in reference 1, making the proper correction for T_s . The total fuel

expenditure was determined to be 7.44 pounds between the times of 3.15 and 9.30 seconds to produce a gross impulse of 3060 pound-seconds. The ratio of these values demonstrates that an over-all value of fuel specific impulse of 412 seconds was obtained and may be compared to that of 200 seconds for solid-propellant rocket fuels and 1050 and 956 seconds for the gaseous-fuel ram jets reported in references 6 and 7.

The failure of the combustor shell prevented proper utilization of the remaining fuel in the ram jet. It also introduced a side force which caused the model to describe a violent maneuver. The combination of the above factors abruptly terminated the flight. This combustor failure paralleled those of the ground tests reported in reference 1 and of other solid-fuel flight tests reported in reference 2. Reference 7 indicates that a 0.05-inch-thick Inconel combustor, incorporated in an ethylene-burning ram jet, tolerated a $C_{T_{g_{max}}} = 0.89$ without failure.

However, the 0.093-inch-thick Inconel combustor of the solid-fuel ram jet failed shortly after a $C_{T_{g_{max}}} = 0.61$ was obtained. It is apparent that this problem of overheating must be eliminated before the full potentialities of solid-fuel ram jets may be realized.

CONCLUDING REMARKS

The important results obtained in a free-flight test of a rocket-launched ram jet powered with a radial-burning solid metallic fuel are as follows:

1. The fuel charge successfully withstood a maximum acceleration of 25g during the boost period.
2. The ram jet accelerated from a Mach number of 1.95 at 4,200 feet altitude to a Mach number of 2.73 at 14,600 feet altitude in the time of 5.5 seconds.
3. The missile experienced a maximum acceleration of 8.6g during free flight.
4. Maximum values of net and gross thrust coefficients of 0.49 and 0.61 were calculated.
5. A maximum value of air specific impulse of 148 seconds was obtained at a Mach number of 2.35 with the free-stream stagnation temperature equal to 1050 F⁰absolute.
6. An over-all fuel specific impulse of 412 seconds was calculated.

7. Combustion-chamber failure, observed at a Mach number of 2.73, prevented the ram jet from reaching a higher Mach number.

Langley Aeronautical Laboratory,
National Advisory Committee for Aeronautics,
Langley Field, Va.

REFERENCES

1. Bartlett, Walter A., Jr.: Evaluation of End- and Radial-Burning Solid Fuels in Ram Jets Mounted in a Free Jet at Mach Numbers of 2.0, 2.2, and 2.3. NACA RM L52I19, 1952.
2. Scott, R. C.: Solid-Fuel Ramjets III. Final Flight Test Report of Six PTV-N-4e (MTV Mk 1 Mod 3) Magnesium-Fueled Test Vehicles. Tech. Pub. No. 53 (Contract NOrd 9756, Bur. Ord., Dept. Navy), Experiment Inc., May 1, 1952.
3. Squiers, John C.: Summary Report on Solid Fuel Ram Jet Development. Continental Aviation and Engineering Corp., July 30, 1950 (Air Forces Contract W-33-038-ac-13371).
4. Faget, Maxime A., Watson, Raymond S., and Bartlett, Walter A., Jr.: Free-Jet Tests of a 6.5-Inch-Diameter Ram-Jet Engine at Mach Numbers of 1.81 and 2.00. NACA RM L50L06, 1951.
5. Beer, A. C.: An Analytical Approach to Ramjet Design Optimization. Bumblebee Rep. No. 108, The Johns Hopkins Univ., Appl. Phys. Lab., Dec. 1949.
6. Faget, Maxime A., and Dettwyler, H. Rudolph: Initial Flight Investigation of a Twin-Engine Supersonic Ram Jet. NACA RM L50H10, 1950.
7. Dettwyler, H. Rudolph, and Bond, Aleck C.: Flight Performance of a Twin-Engine Supersonic Ram Jet From 2,300 to 67,200 Feet Altitude. NACA RM L50L27, 1951.

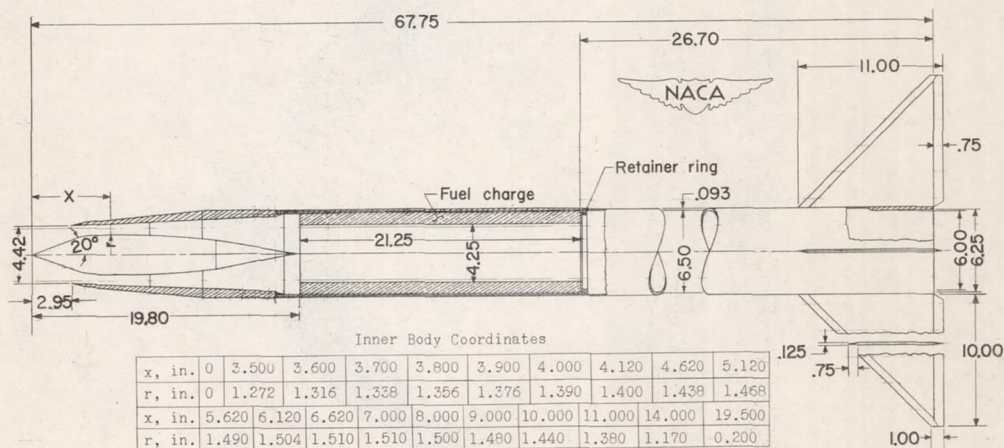

(a) Sketch of model. All dimensions are in inches.

Figure 1.- The solid-fuel ram jet.

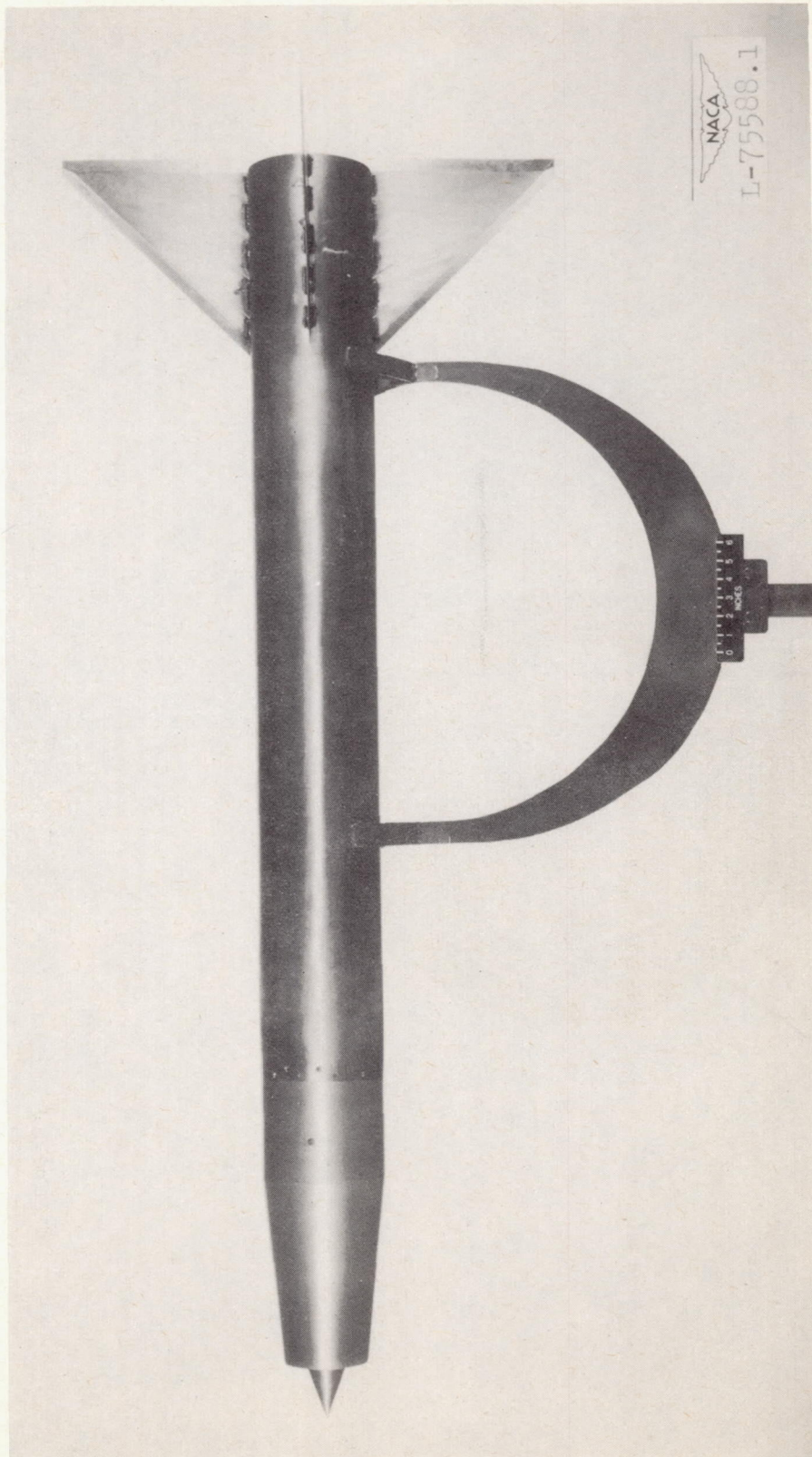

(b) Photograph of model.

Figure 1.- Concluded.

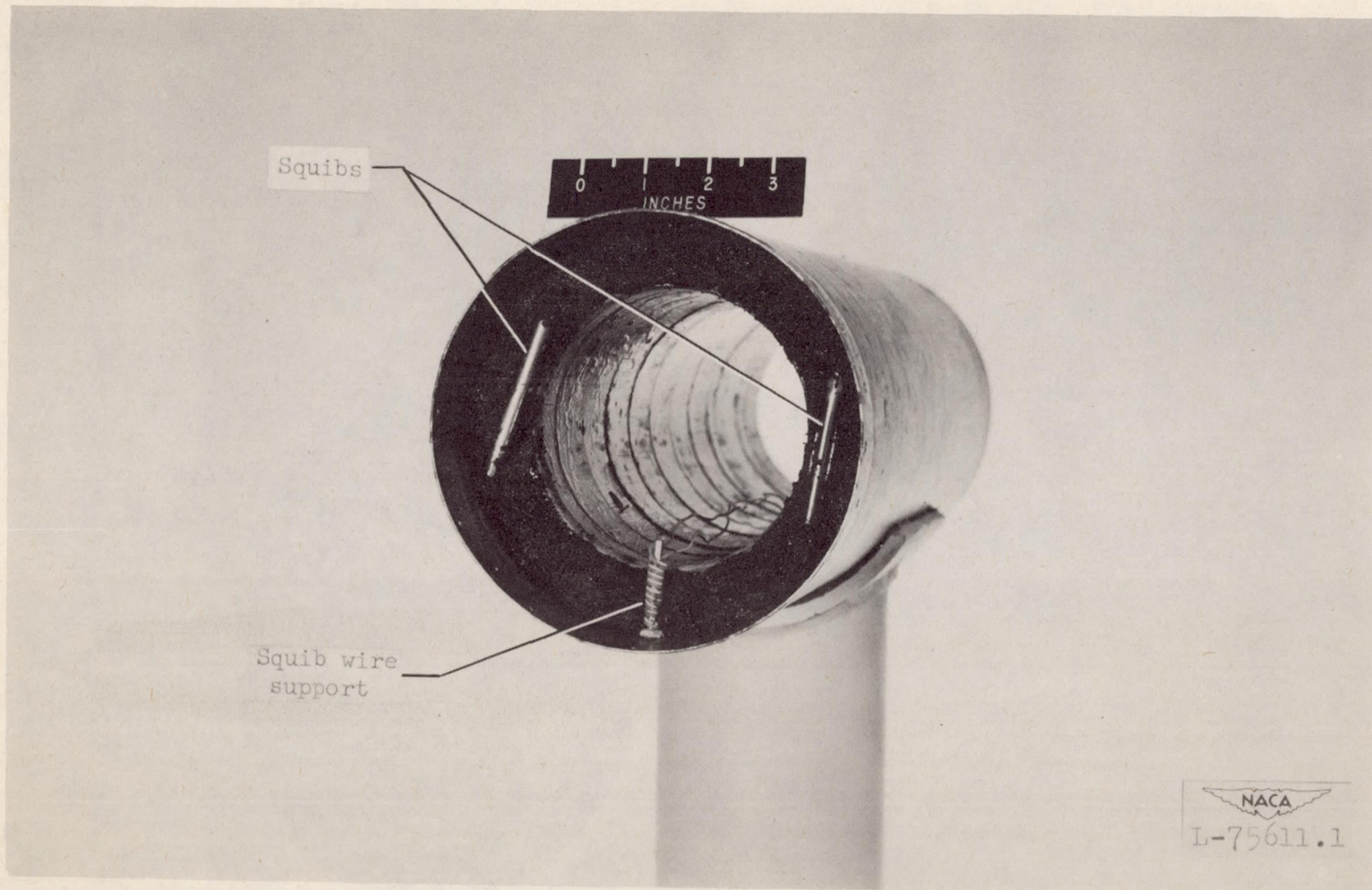

Figure 2.- Front view of radial-burning solid-fuel charge showing igniter assembly.

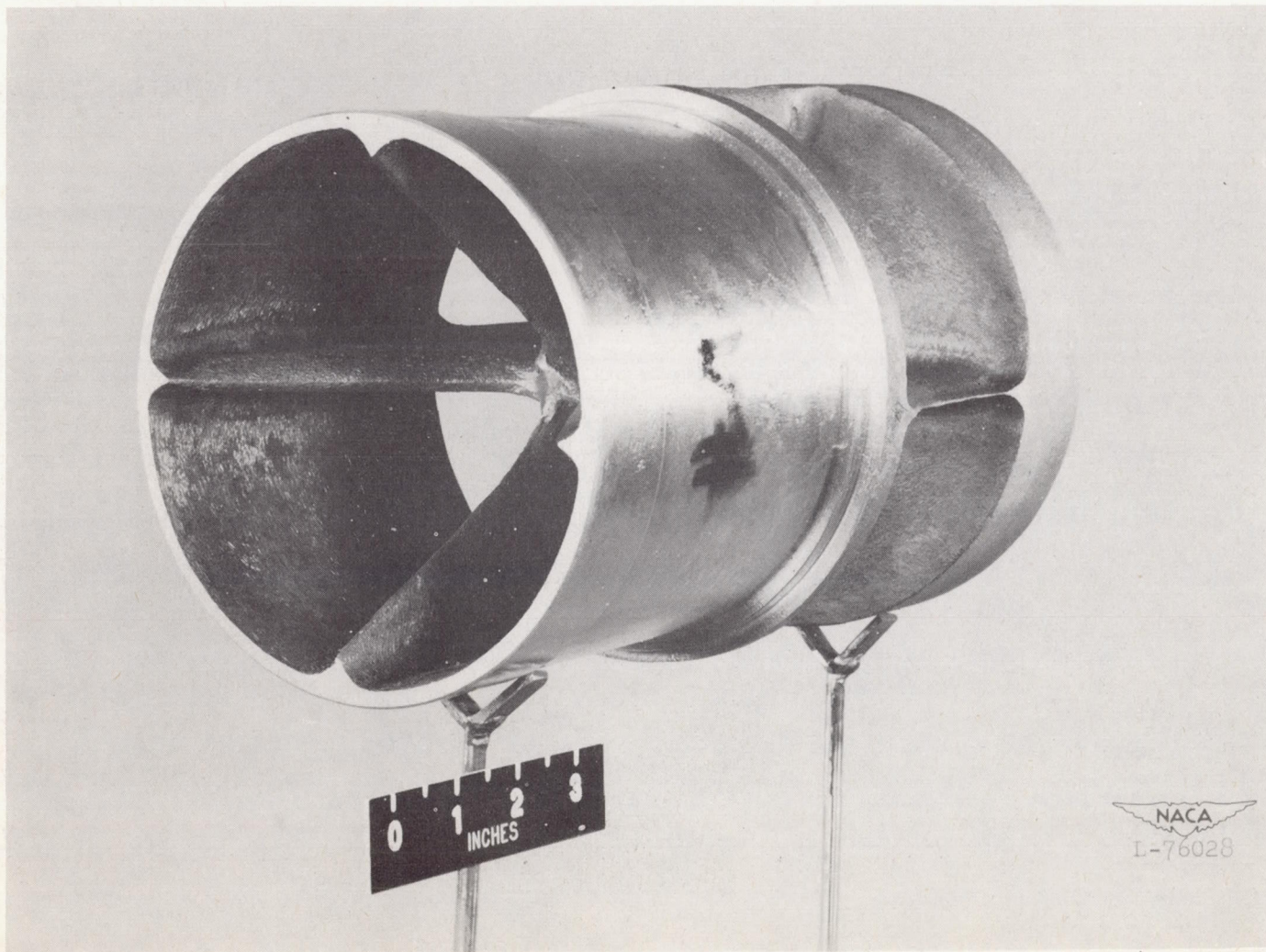

Figure 3.- The cast magnesium booster adapter - three-quarter front view of section which fits in the ram-jet exit nozzle.



Figure 4.- The test model and booster in the launching attitude.

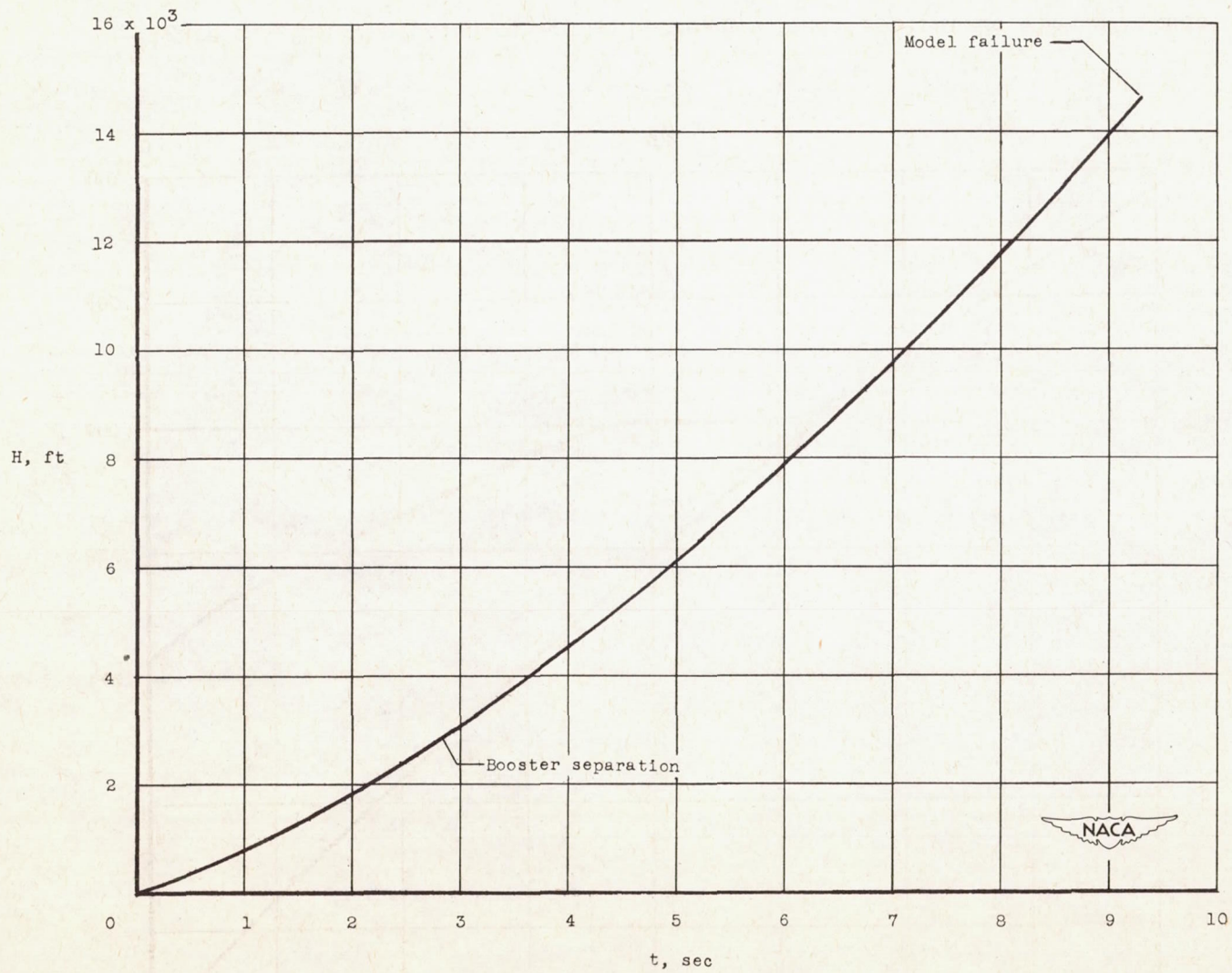

Figure 5.- The variation of altitude with flight time for the solid-fuel ram jet.

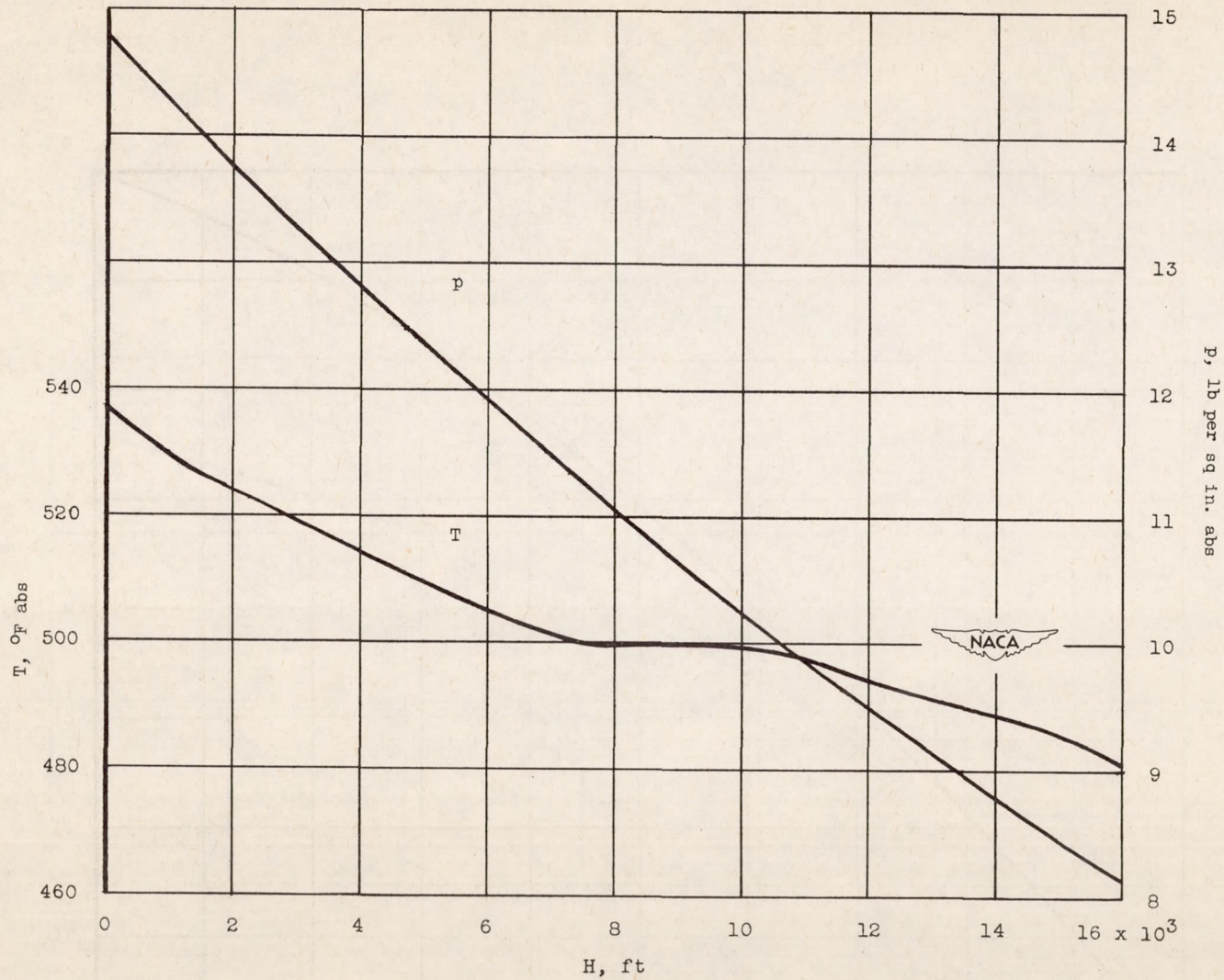

Figure 6.- The variation of ambient pressure and temperature with altitude.

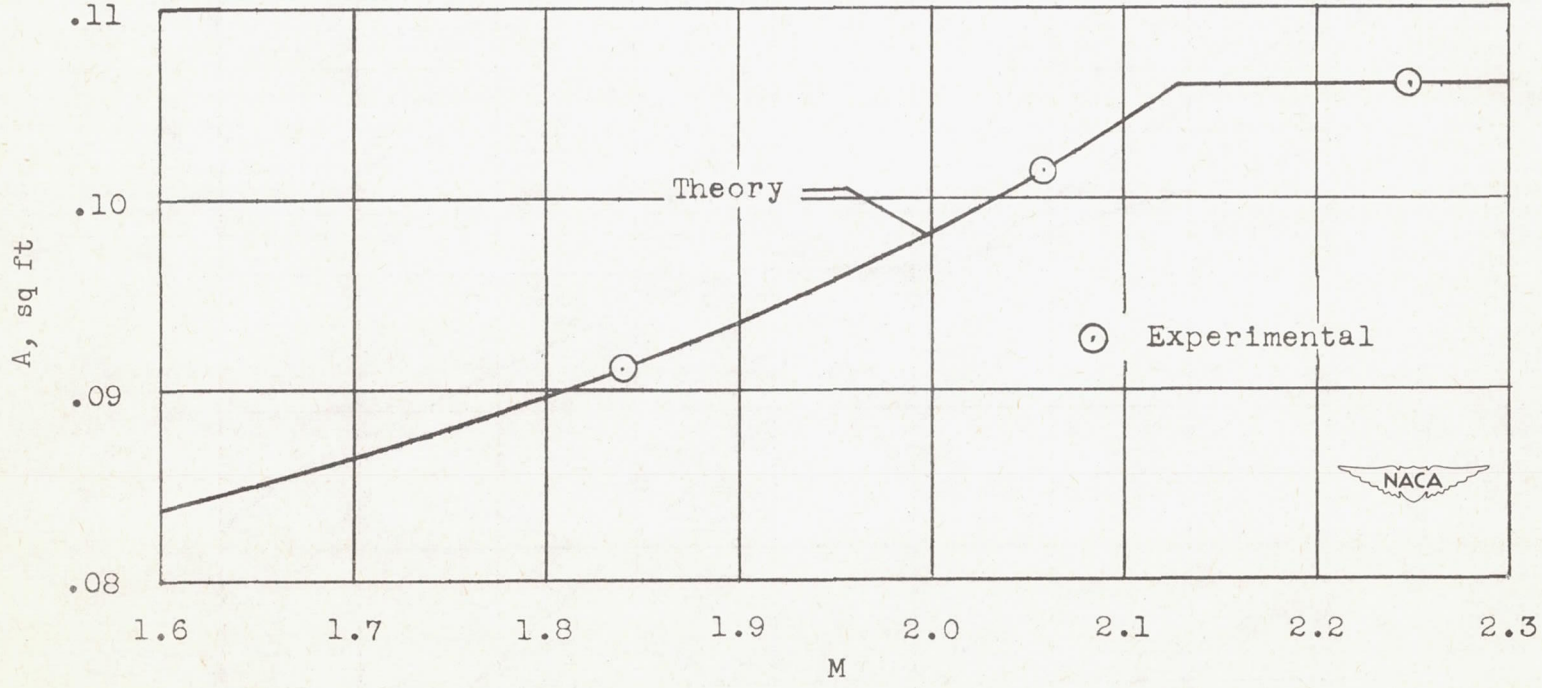

Figure 7.- The variation of inlet capture area with flight Mach number as determined from theory and ground tests by the methods of reference 4.

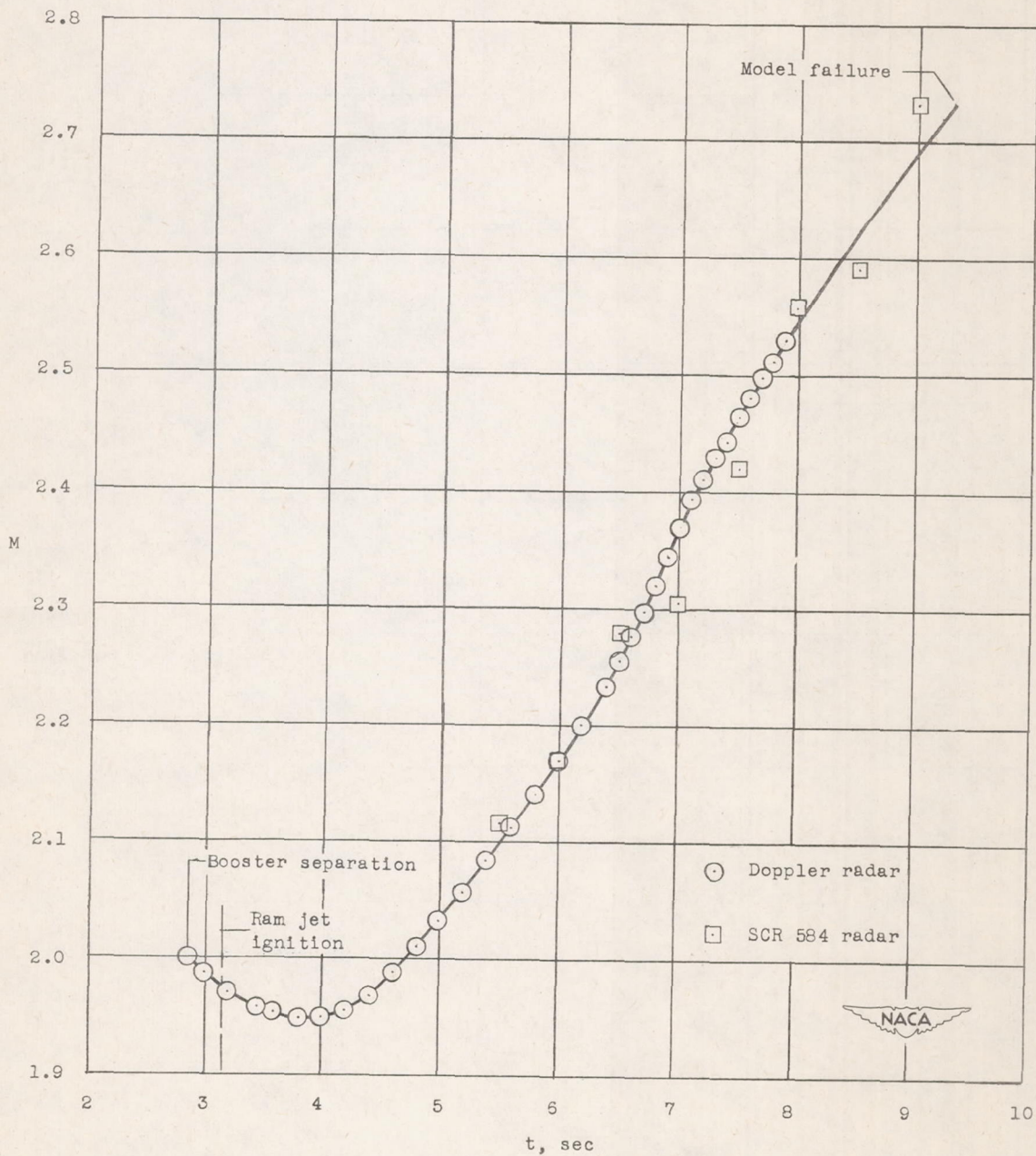

Figure 8.- The flight Mach number against time.

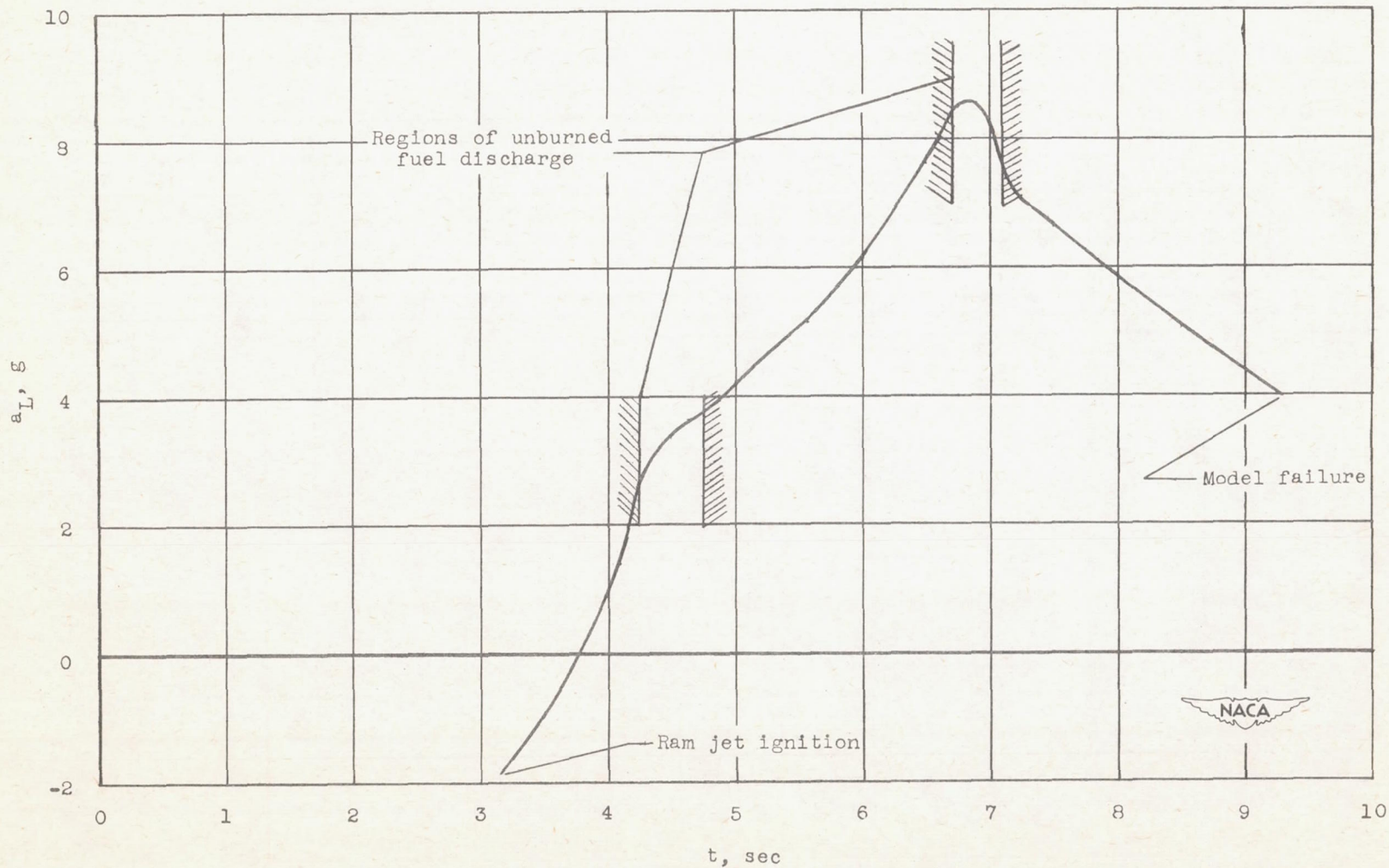

Figure 9.- The absolute longitudinal acceleration of the model against flight time.

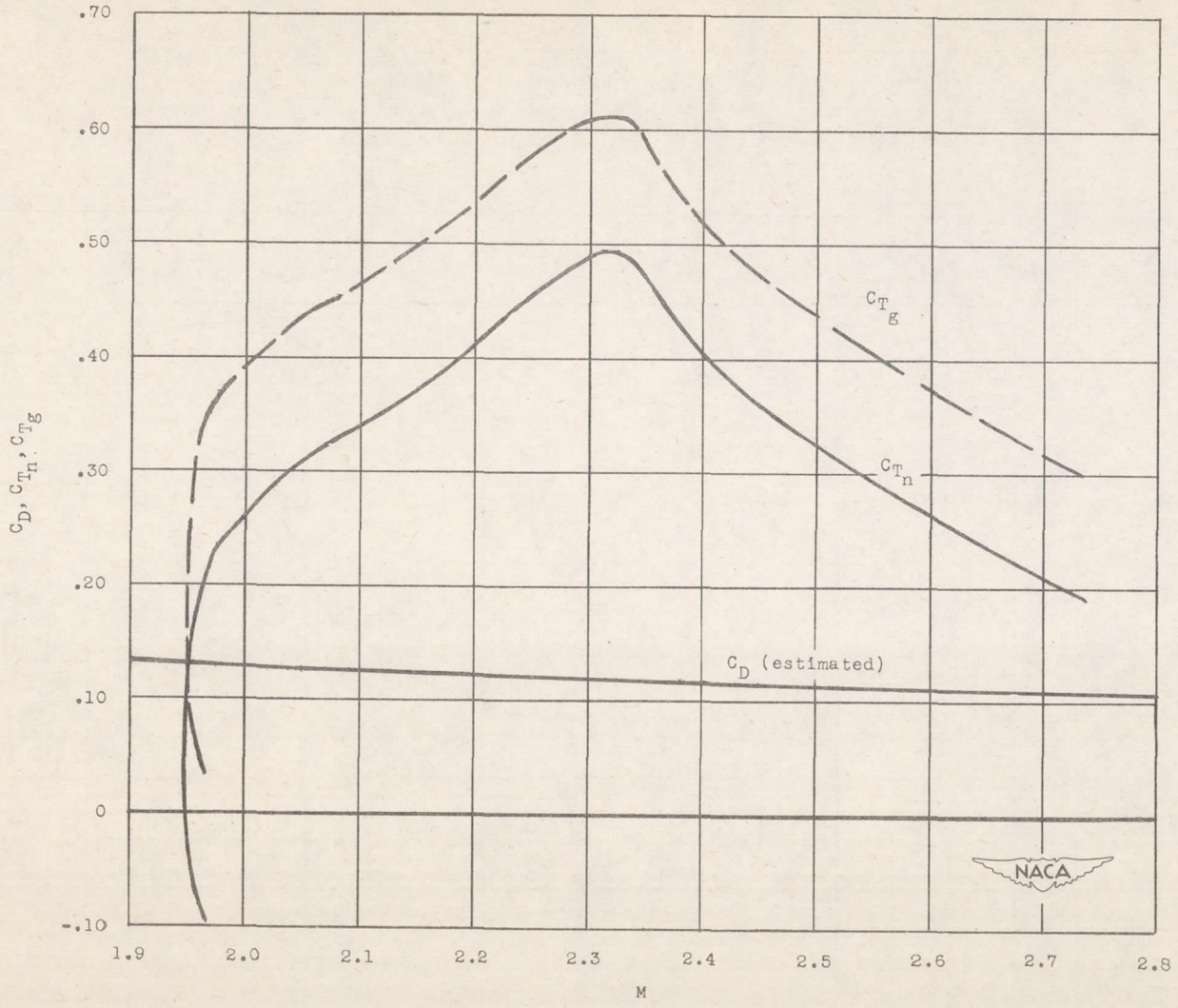

Figure 10.- The variation of thrust and drag coefficients with Mach number.

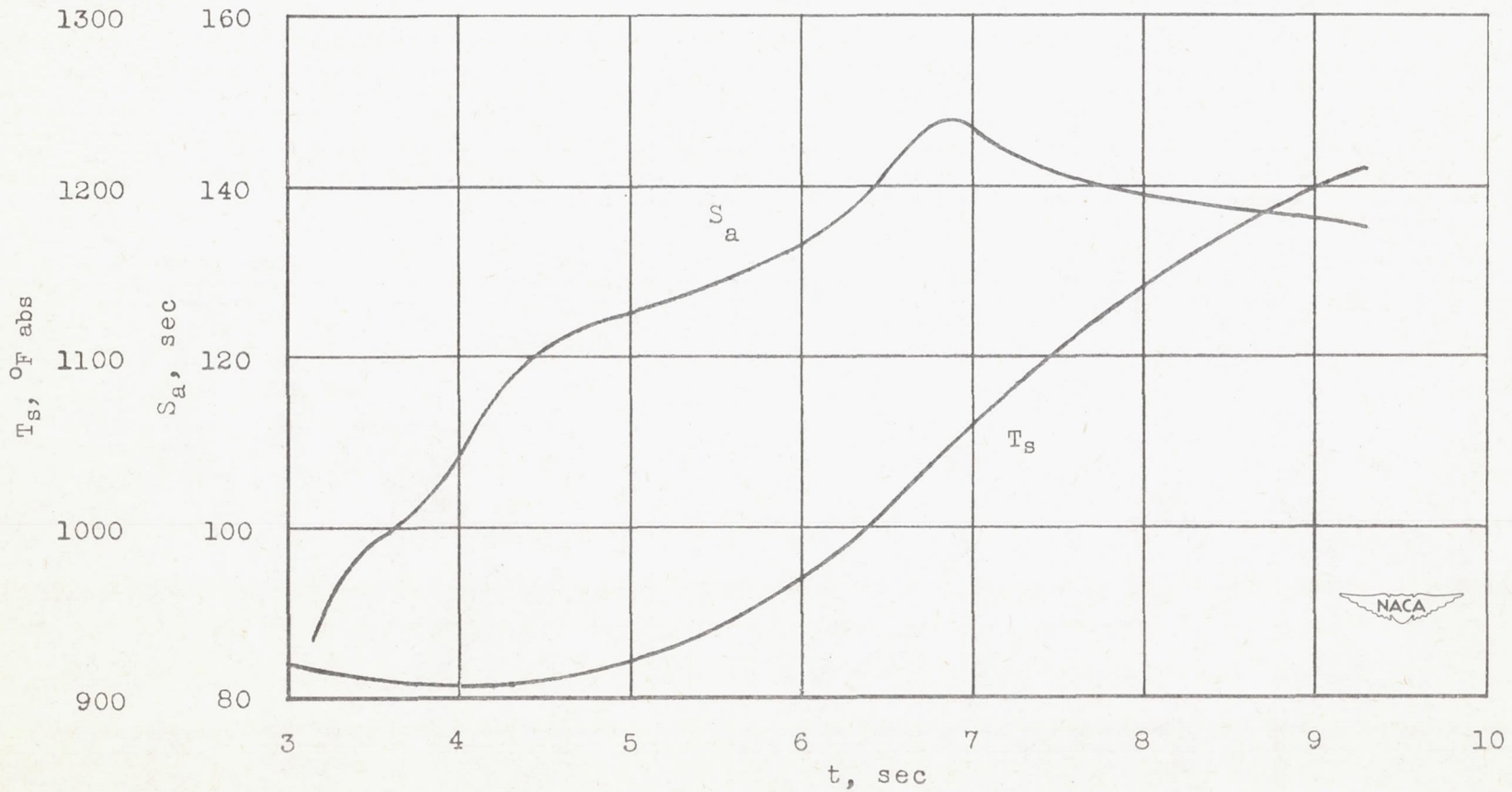

Figure 11.- The computed air specific impulse and stagnation temperature plotted against time.

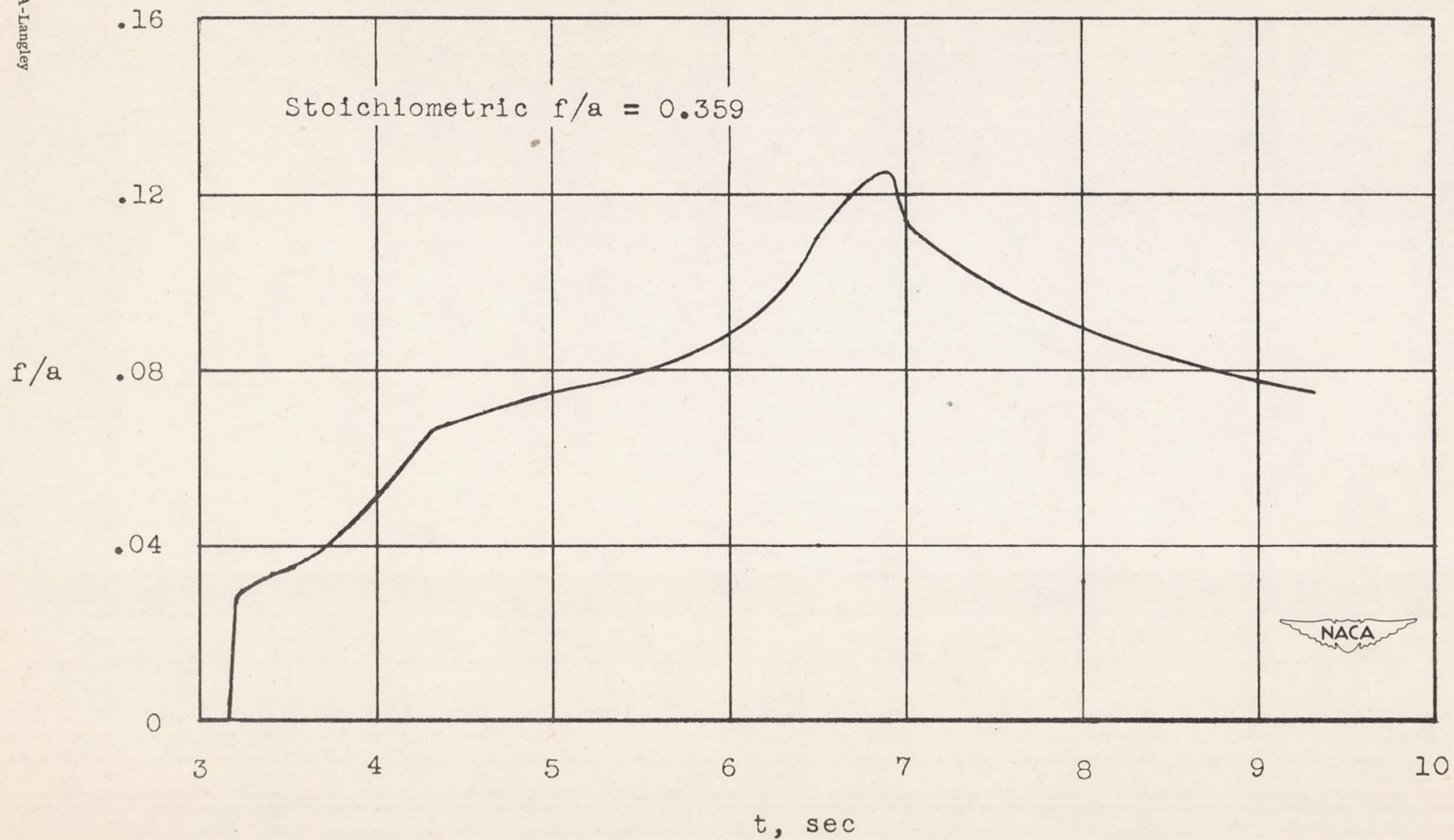

Figure 12.- The variation of fuel-air ratio during the flight.