

FILE COPY
NO. 6

AIRCRAFT CIRCULARS
NATIONAL ADVISORY COMMITTEE FOR AERONAUTICS

No. 184

THE COMPER "MOUSE" COMMERCIAL AIRPLANE (BRITISH)
A Three-Seat Cabin Low-Wing Monoplane

FILE COPY

To be returned to
the files of the National
Advisory Committee
for Aeronautics
Washington, D. C.

Washington
October 1933

NATIONAL ADVISORY COMMITTEE FOR AERONAUTICS

AIRCRAFT CIRCULAR NO. 184

THE COMPER "MOUSE" COMMERCIAL AIRPLANE (BRITISH)*

A Three-Seat Cabin Low-Wing Monoplane

The "Mouse" is a low-wing cantilever monoplane with a cabin for three people (figs. 1, 2, 3, 4, 5, and 6). It has a D.H. Gipsy Major engine and is designed to cruise at 130 m.p.h. for 600 miles, and to alight alowly.

The "Mouse" has four outstanding features. Of the greatest technical interest is the retractable landing gear, for which a provisional patent was granted last December. Each wheel and its axle is carried in a welded structure of square steel tubes, in which, for purposes of springing, it is arranged to slide up and down in horn-blocks against rubber pads (fig. 7).

The front of each unit is supported by a torque tube carried behind the front spar and by turning this tube the whole unit can be swung up into the wing between the spars or dropped down for landing. Each unit is locked up or down by spring-loaded pins which engage with fittings on specially strengthened ribs. These pins are automatically withdrawn when the torque tubes are turned.

To make the mechanism easy to work, each unit has its own lever. The two are mounted close together between the front seats. By way of warning a red lamp automatically lights up if the throttle is pulled back when the wheels are up.

Another innovation is the method of folding the wings (figs. 5, 8, and 9). In this new patented Comper system the hinges lie between the front and rear spars and only do work during the folding of the wings. The latter are attached to the center section by vertical pins, through fittings on the ends of the spars in the usual way. They are screwed in but can be quickly withdrawn.

Each wing is then pulled away from the center section but remains supported on a large tube about which it is

*From The Acroplane, September 27, 1933, and Flight, September 28, 1933.

rotated until the leading edge is pointing down to the ground. The tube is hinged so that the wing can then be folded back against the fuselage. No flaps are needed and the aileron controls are uncoupled automatically. By this ingenious system the main spar fittings are protected against wear and the development of shake which might lead to wing flutter.

The next special feature is the patented sliding roof over the cabin (figs. 4 and 10). This can be slid open in the air, an obvious advantage when approaching an airport in bad weather or when about to make a forced landing under conditions that may lead to the airplane turning over.

Finally the two front seats in the cabin are arranged side by side, which is the best arrangement for instruction and the most pleasant for conversation (figs. 10 and 11). Either of these can be unfastened and slid back so that the occupant who is not piloting can move back and talk comfortably to the third person who sits in the middle behind them.

The "Mouse" is particularly "clean." A refinement worthy of note is that the push rods for working the ailerons are completely enclosed within the wings and are attached to the aileron spars just above the hinges (fig. 12).

Structurally the "Mouse" follows well-proved Comper practice. It is built entirely of wood and the wing, except for the leading edge, is covered with fabric. (See figs. 13, 14, 15, 16, 17, and 18.) The fuselage is a built-up wooden girder covered for the most part with fabric. This simple type of construction has proved extremely robust in service and is easy to repair.

An interesting technical development is the special type of joint used throughout the control system. It consists of a ball, swiveling freely, and held between two flanged plates on the end of the push rod. The other rod ends in a fork, the pin of which goes through the ball. The whole thus forms a universal joint.

SPECIFICATION

Type.- Three-seat cabin monoplane for the private owner, for air-taxi work, or other commercial operation.

Wings.- Low-wing cantilever monoplane, tapering in chord and thickness. Outer wing sections set at 5 degrees dihedral and attached to center section by vertical pins, with folding lever handles, screwed into fittings. On withdrawal of pins each wing is pulled outward on large tube mounted between spars, twisted into vertical plane and folded back against fuselage. Two tapered box spars of spruce and plywood. Triangulated girder-type drag and antidrag bracing provides torsional strength. Girder-type ribs, except in center section, where closely spaced ribs are of box type. Welded-up fittings of mild steel. Leading edge covered with plywood from top of spar to stringer underneath forward of lower spar flange. Plywood covering at wing roots, the rest being covered with fabric. Mass, but not aerodynamically, balanced ailerons with D-tube spars, cantilever ribs and fabric covering.

Fuselage.- Divided behind cabin. Wooden girder structure with spruce members and pinned and glued plywood "biscuits" at joints. Front portion rests on center section and is fastened thereto by three fittings each side. Stringers along deck. Fabric covering.

Tail unit.- Wooden stabilizer with routed spars and solid spruce diagonal bracing covered with fabric and mounted on top of fuselage. Hinged at rear spar with adjustable struts to bottom of fuselage. Fittings beneath front spar for adjusting incidence on ground. Unbalanced elevators with wooden box spar and flanged steel ribs welded to tubular trailing edge. Cantilever fin and unbalanced rudder of welded steel tube covered with fabric.

Landing gear.- Retractable type with 1.83 m (6 ft.) track. Each unit of welded-up square steel tube carried by torque tube at back of front spar and is raised or lowered by turning tube. Units locked up or down by spring-loaded pins at back of each unit which engage with fittings at each end of travel. Axles carried by bronze blocks sliding between guides against rubber pads for springing. Dunlop low-pressure wheels and brakes. Tracking Dunlop tail wheel carried by leaf springs (fig. 19).

Power plant.- One 130 hp. D.H. Gipsy Major air-cooled 4-cylinder in-line inverted engine on welded steel-tube mounting in front of fireproof bulkhead. One 42.75-liter (9-1/2-gallon) riveted and soldered steel tank in each wing root, and one 62-liter (13-3/4-gallon) gravity tank beneath decking behind fireproof bulkhead. System always starts on gravity, pumps are then automatically primed and draw from wing tanks. Excess passes to gravity tank and overflows back to wing tanks. Last half-hour's supply contained in separate gravity tank. Tanks and pipes are ranged for filling through one large aperture in top tank or separate orifices in each. One 11.25-liter (2-1/2-gallon) cylindrical oil tank arranged athwart fuselage with passage through it for cooling.

Accommodation.- Two side-by-side sliding seats immediately behind front spar. Third seat behind in middle of cabin. Glazed cover over cabin can be slid right back and provides easy access. Leather upholstery. Large locker for three suitcases, supplied with each airplane, behind cabin. Lockers also built into wing roots.

Controls.- Control column and rudder bar with adjustable pedals in front of each front seat. Brakes applied by lever and controlled differentially by rudder bars. Landing-gear raising levers between seats. All control rods and wires covered in cabin. Aileron system push rods throughout. Elevator system push rods to back of cabin and thence double wires. Double wires for rudder.

Dimensions:

Length	7,645 mm	25 ft. 1 in.
Height	1,676 "	5 " 6 "
Span	11,430 "	37 " 6 "
Width, folded	3,607 "	11 " 10 "
Track	1,829 "	6 " 0 "

Areas:

Wing (total)	16 m ²	172.0 sq.ft.
Ailerons (included above)	2.2 m ²	24 "

Areas (continued):

Stabilizer	1.8 m ²	20 sq.ft.
Elevators	1.1 "	12 "
Fin	0.5 "	5.15 "
Rudder	0.7 "	8.05 "

Weights:

Weight, empty	589.7 kg	1,300 lb.
Fuel	133.8 "	295 "
Pay load and pilot	281.2 "	620 "
	1,004.7 "	2,215 "
Acrobatic	907.2 "	2,000 "

Performances (estimated):

Cruising speed, about	209.2 k.p.h.	130 m.p.h.
Range	965.6 km	600 miles

Loadings:

Wing loading	62.98 kg/m ²	12.9 lb./sq.ft.
Power "	7.7 kg/hp	17.0 lb./hp.

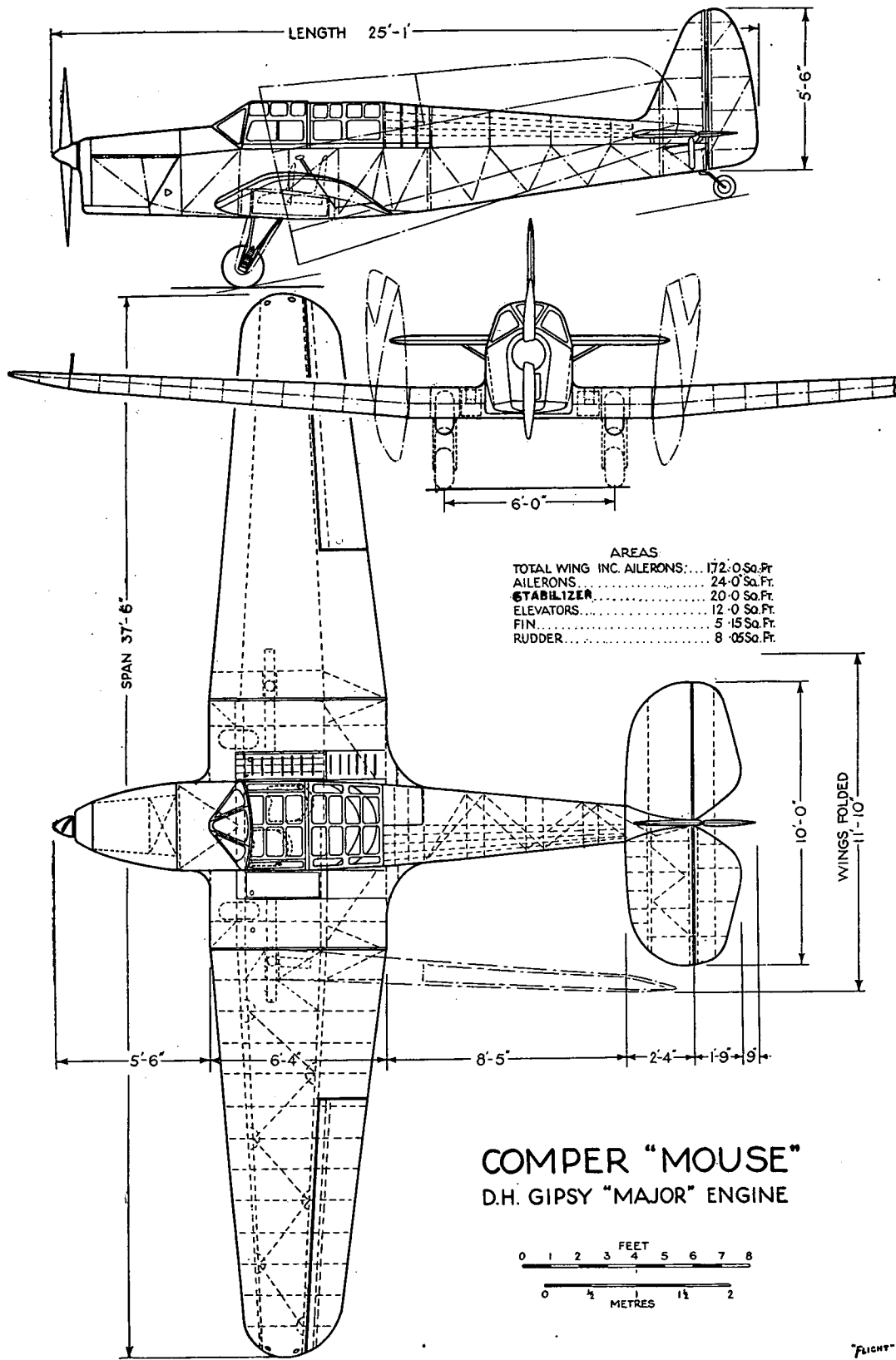

"FLIGHT"

Fig.1-General arrangement drawings of the Comper "Mouse" airplane.



"Flight"

Figure 2.-Three-quarter front view of the Comper "Mouse" airplane.

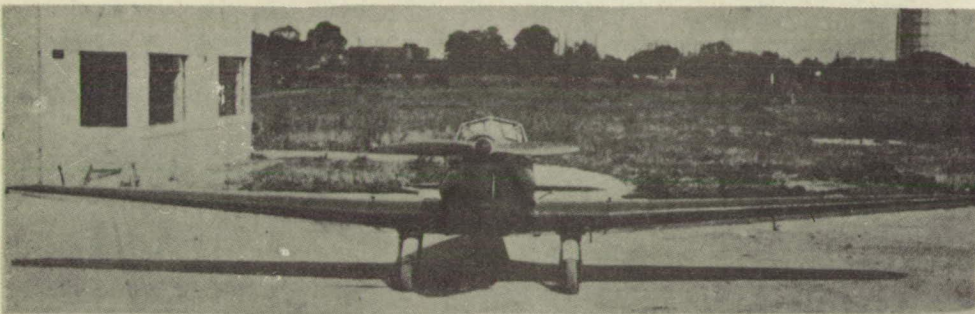

Figure 3.-The front view of the "Mouse" emphasizes the clean design. *"Flight"*

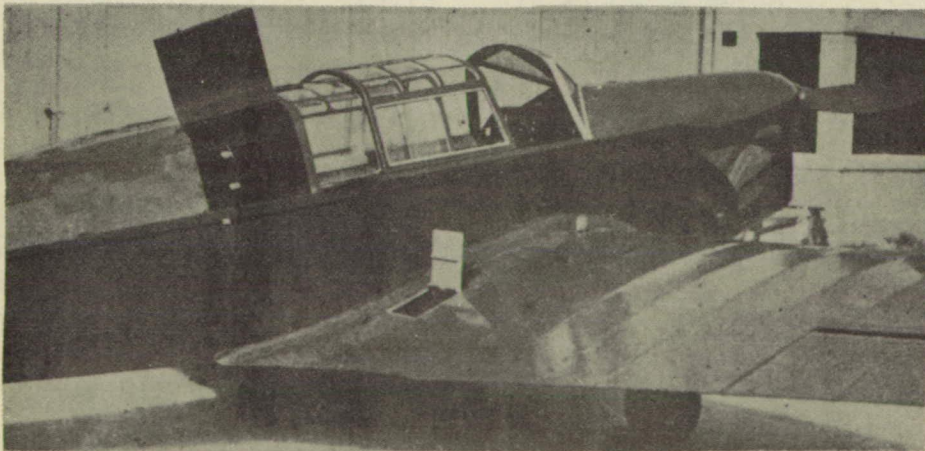

Figure 4.-The cabin of the "Mouse" is light and airy, as it is fitted with a form of sunshine roof. The small locker in the wing root can be used for tools and log books. The luggage locker, as shown, holds three suit cases. *"Flight"*

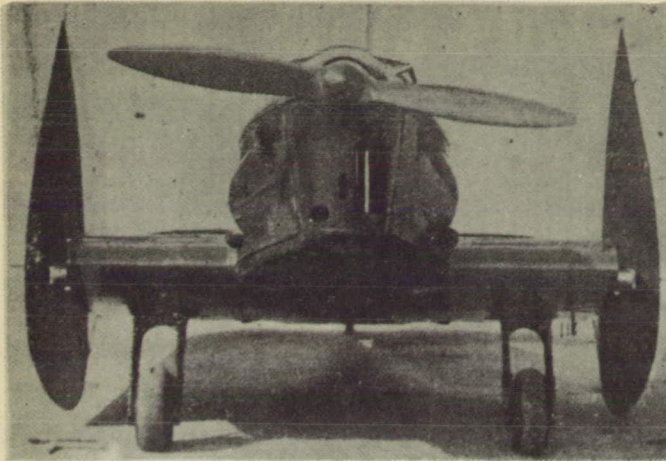

Figure 5.-View showing the neat design of the landing gear. The clean engine cowling around the "Gipsy Major" and the small space taken by the "Mouse" when folded. "Flight"

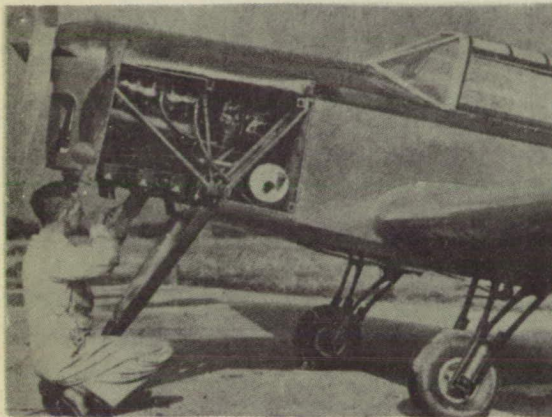

Figure 6.-Accessibility of the engine of the "Mouse" with the three cowling panels open. "The Aeroplane"

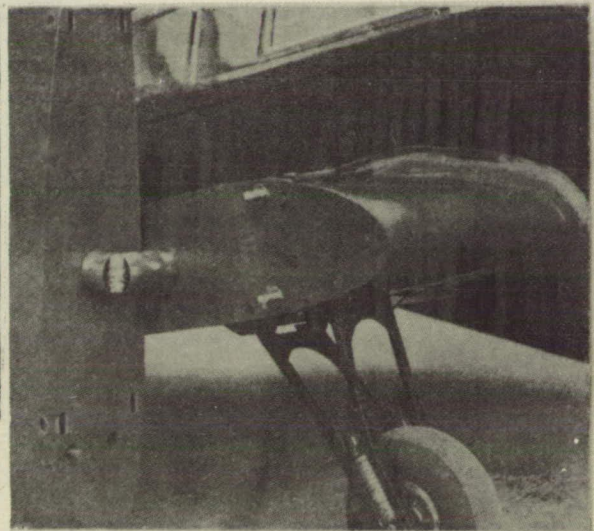

Figure 8.-Photograph of the folded wing. "Flight"

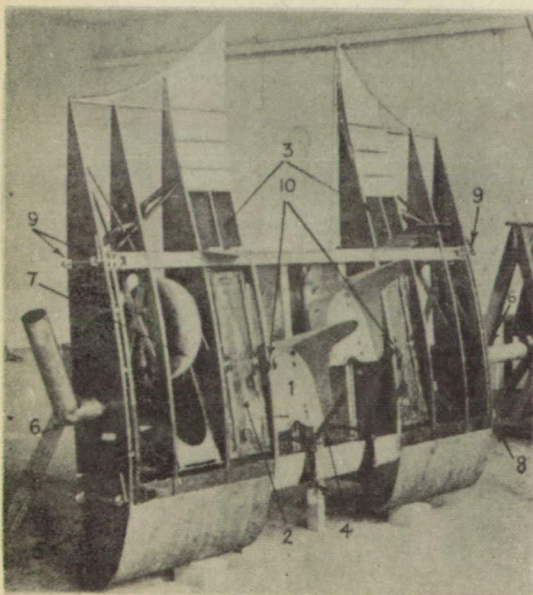

Figure 11.-The center section is built as a separate unit. 1, An adjustable seat sliding on runners. 2, The starboard wing fuel tank. 3, Small lockers for tools and log books. 4, A control column, working the push rods which leave the wing at 5, where they end in rubber buffers. 6, The elbow joint upon which the wing folds. 7, A landing gear wheel retracted. 8 and 9, The wing root spar bolts. 10, The center attachment point of the fuselage. "Flight"

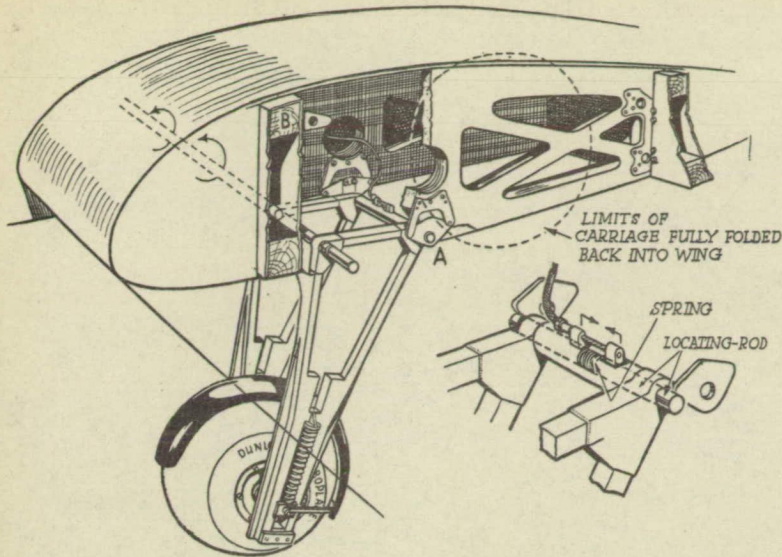

Figure 7.-
One unit
of the re-
tractable
landing
gear of
the Comper
Mouse air-
plane. "The
Aeroplane"

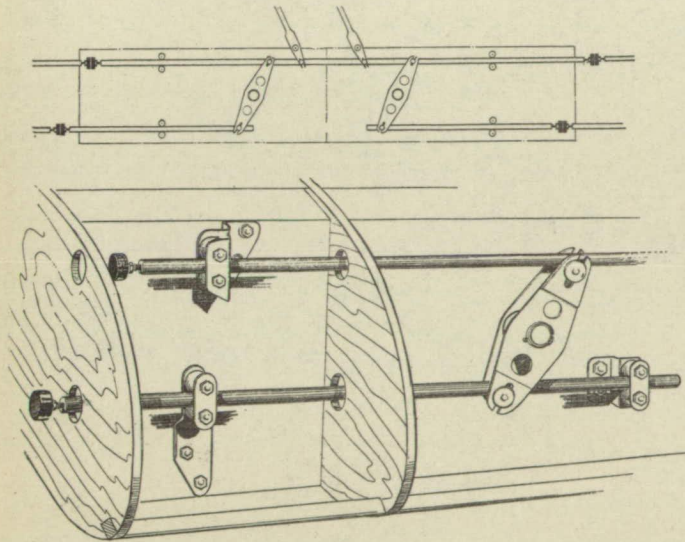

Figure 12.-Sketch
explain-
ing the action of
the push-push rods
for working the
ailerons, while at
the same time pro-
viding a system
which does not have
to be uncoupled
when the wings are
folded. "Flight"

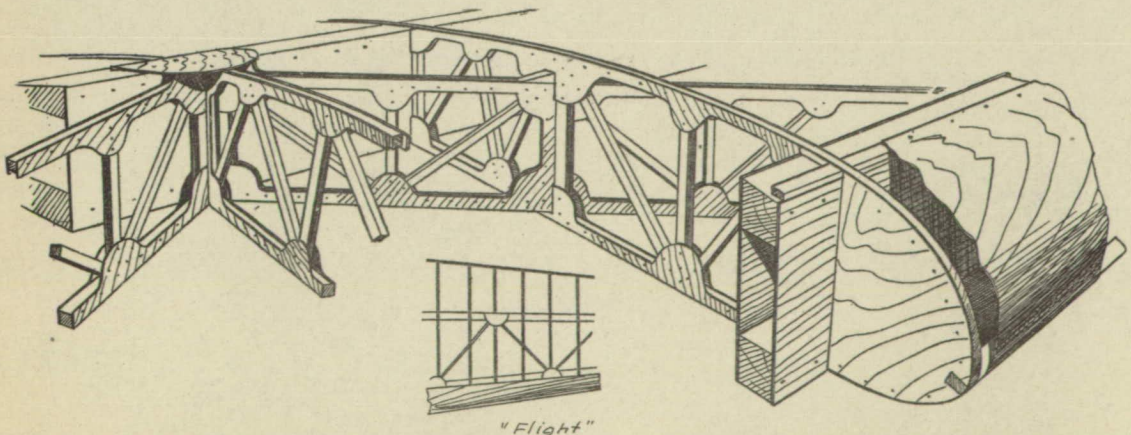

Figure 13.-General structure of the wing of the "Mouse" airplane.

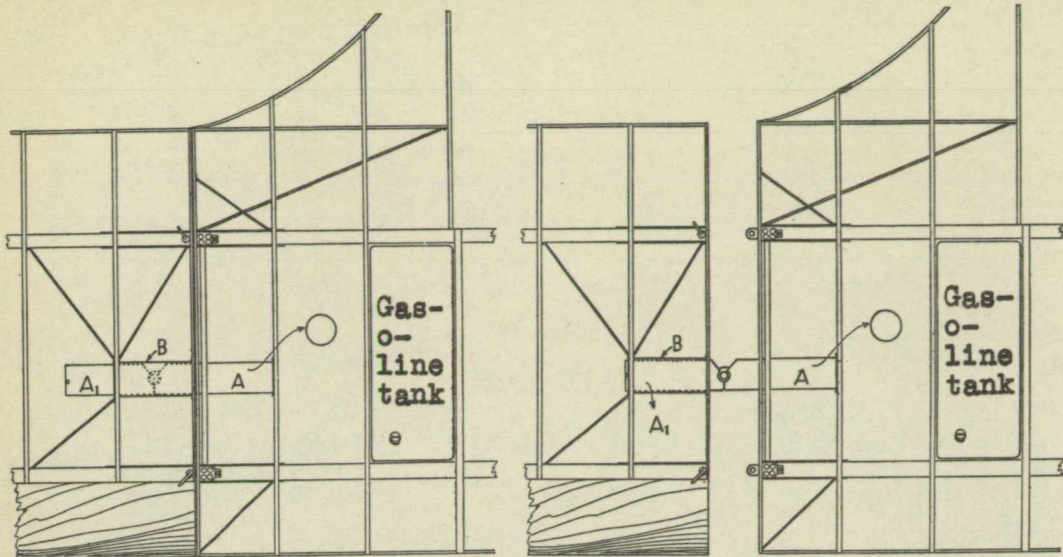

Figure 9.—These three sketches show how the wing folds. The jointed tube A is anchored in the center section and passes through the tube B. "Flight"

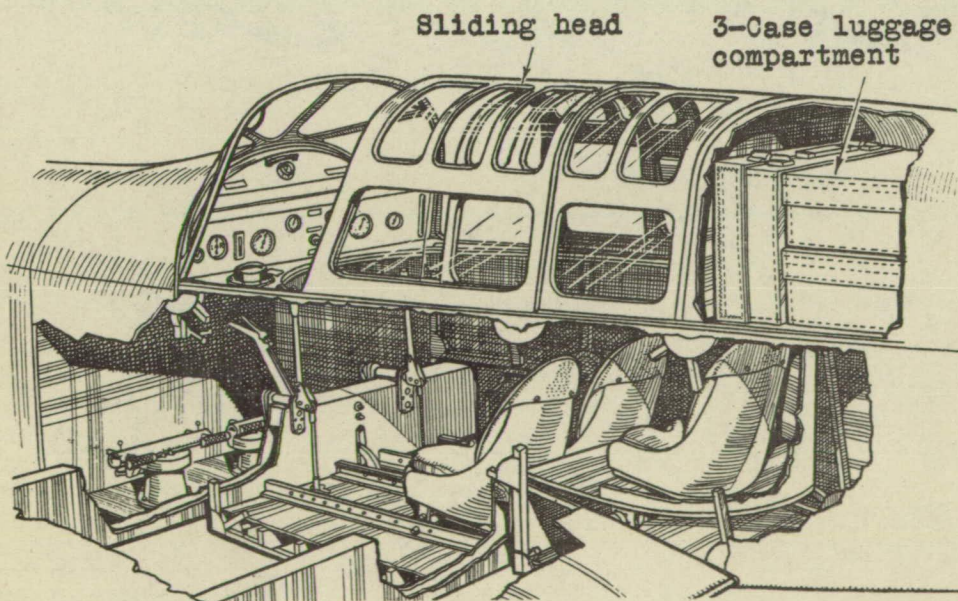
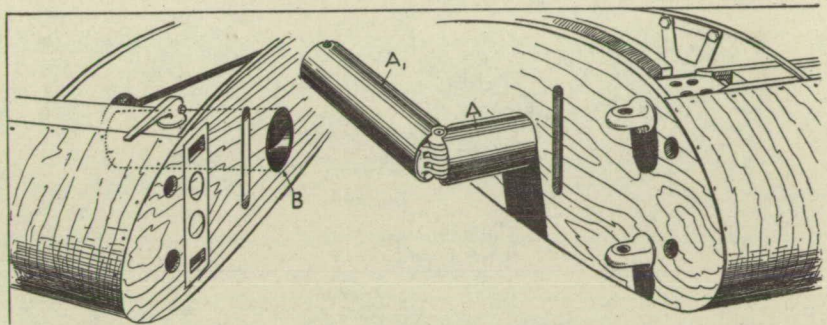

Figure 10.—Arrangement of seats, controls, luggage compartment, etc. The two front seats are in the full back position to show the two control columns. "The Aeroplane"

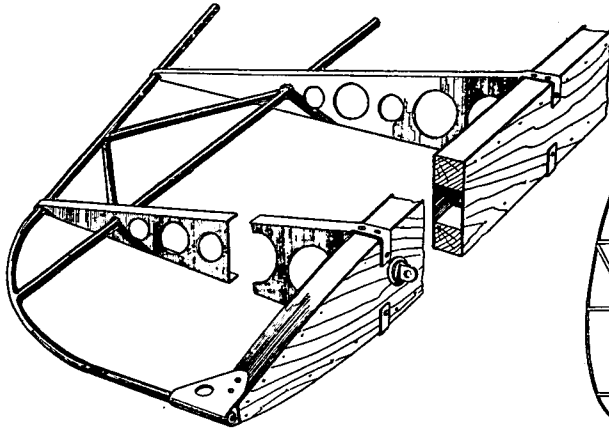

Figure 14.- The stabilizer has a boxed wooden spar with steel ribs. "Flight"

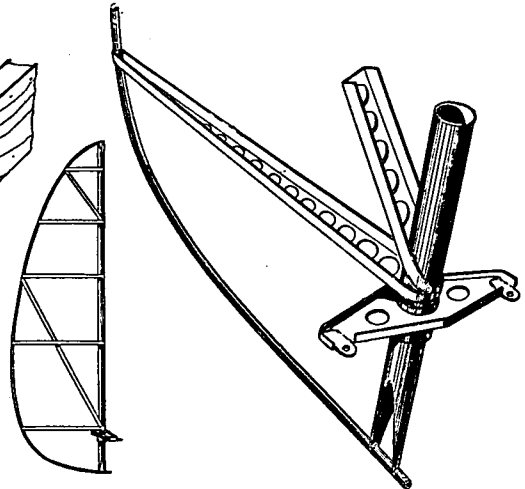

Figure 15.- The rudder is all steel. "Flight"

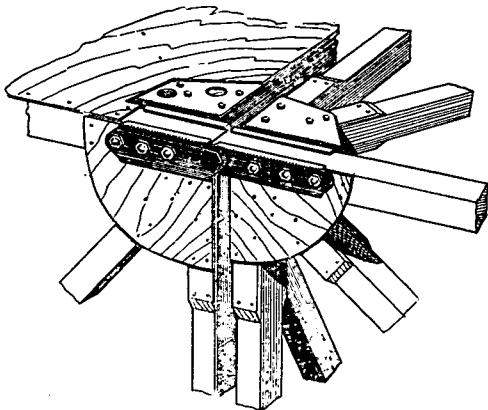

Figure 16.- A fuselage joint between the rear portion and the cabin; large plywood biscuits and steel fish plates are used. "Flight"

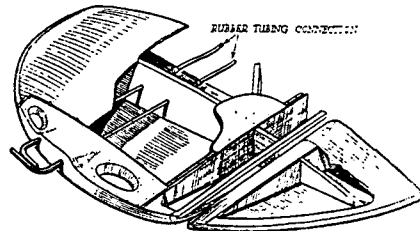

Figure 17.- Wing-tip and combined pitot-head and lifting handle. "The Aeroplane"

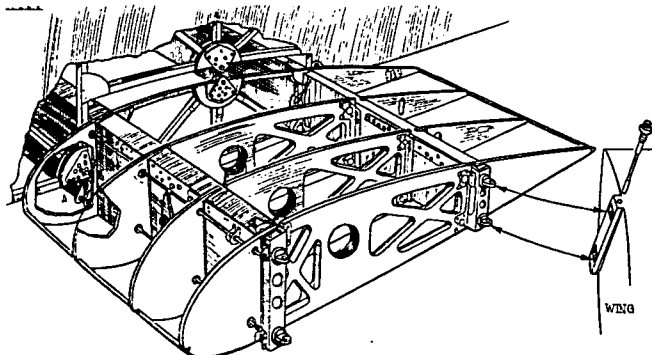

Figure 18.- Wing details. Center section just dropped clear of the fuselage. "The Aeroplane"

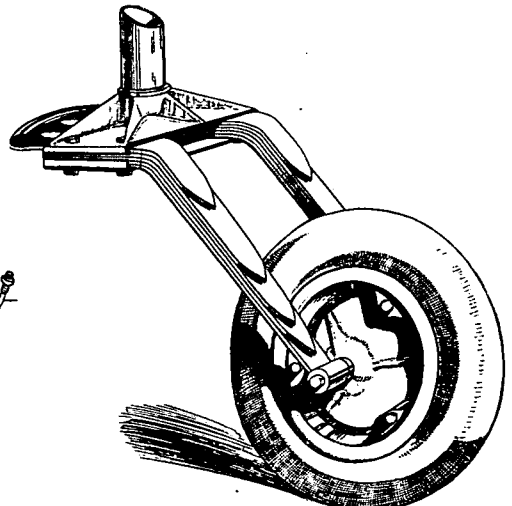

Figure 19.- The tail wheel mounted on a spring steel fork. "Flight"