

FILE COPY  
NO. ~~2~~

FILE COPY  
NO. I-W

CASE FILE  
COPY

TECHNICAL MEMORANDUMS  
NATIONAL ADVISORY COMMITTEE FOR AERONAUTICS

---

No. 347

---

TWO-STROKE-CYCLE ENGINES FOR AIRPLANES

By J. Jalbert

From "L'Aeronautique," July and August, 1925

---

Washington  
January, 1926

**FILE COPY**

To be returned to  
the files of the National  
Advisory Committee  
for Aeronautics  
Washington, D. C.

NATIONAL ADVISORY COMMITTEE FOR AERONAUTICS.

TECHNICAL MEMORANDUM NO. 347.

TWO-STROKE-CYCLE ENGINES FOR AIRPLANES.\*

By J. Jalbert,

All airplanes are now equipped with four-stroke-cycle engines. This fact is explained by the degree of perfection they had attained in automobiles, which had used them from the first, because this type already existed in a very acceptable though not absolutely perfect condition. Airplane engines were the result of the improvement and lightening of automobile engines. They retained the four-stroke cycle and complications requiring successive improvements and entailing, in their turn, an increasingly high cost of production and upkeep.

Now that the two-stroke cycle has begun to make its appearance in automobiles, it is important to know what services we have a right to expect of it in aeronautics, what conditions must be met by engines of this type for use on airplanes and what has already been accomplished.

Cyclic regularity.- The qualities desired of an airplane engine are cyclic regularity, running regularity, minimum weight, small fuel and oil consumption and rapidity of pick-up. The two-stroke cycle, due to its cyclic regularity which is

---

\* From "L'Aéronautique," 1925, July (pp. 255-259) and August (pp. 295-299).

double that of the four-stroke cycle, constitutes an incontestable improvement over the latter. It is the first timid step toward the turbine.

Simplicity.— Moreover, the theoretical simplicity of this engine type, if not counteracted by mechanical complications, naturally results in running regularity and minimum weight. In fact, the elimination of certain parts, like the valves and their controls (the most fragile parts of a four-stroke engine), assures a longer life to the two-stroke engine.

Small mean pressure.— For a like degree of compression, on the other hand, the maximum explosion pressure is less in a two-stroke than in a four-stroke engine of the same dimensions and the same theoretical compression ratio. When the maximum explosion pressure reaches 27–28 kg/cm<sup>2</sup> (380–398 lb./sq.in.) for a four-stroke engine, it is only 22–23 kg/cm<sup>2</sup> (313–327 lb./sq.in.) for a two-stroke engine, everything else being equal (Fig. 1).

This fact is explained by the presence of exhaust gases in a larger ratio to the fresh gases than in a four-stroke engine, which presence diminishes the initial explosion pressure. The presence of these exhaust gases (moreover, inevitable for obtaining a good fuel consumption, as we shall see farther on) greatly modifies the compression and carries it beyond the theoretical compression determined by the construc-

tion of the cylinder. The exhaust gases act by their volume and by heating the fresh gases which penetrate them.

Due to the fact that the maximum explosion pressure is less than in a four-stroke engine, the moving parts (bushings, rings, bearings) fatigue less and consequently wear less in a two-stroke engine. It is for a similar reason, moreover, that, with the same revolution speed, a two-stroke engine develops only about 1.4-1.6 times the power of a four-stroke engine of like cylinder capacity.

The connecting rods of a two-stroke engine work constantly under compression, while those of a four-stroke engine work under tension during the intake stroke and under compression during the other three strokes. Consequently the wear of the crank end of the connecting rod is almost zero on the two-stroke engine and any play which might exist would not be increased by the functioning of the engine. When the experiment was tried of assembling a two-stroke engine with connecting rods whose crank ends had a play of several tenths of a millimeter, no knocking was perceptible, even to an experienced ear.

It is obvious, from the foregoing, that a two-stroke engine will cost less for construction and upkeep, than a four-stroke engine of like cyclic regularity (provided the construction of the former involves no disadvantageous complications) and that its running regularity will be better.

Reduced heating.- Another important advantage for its use on airplanes resides in the fact that, other things being equal, a two-stroke engine heats less than a four-stroke engine. This is due to the fact that the exhaust gases escape through a port in the cylinder and do not have time to heat the walls, which are, moreover, cooled at the same moment by the fresh intake gases. In a four-stroke engine, on the contrary, the exhaust gases heat the walls during the whole of the exhaust stroke.

The curves in Fig. 2 relate to two 140 HP. engines, one a four-stroke and the other a two-stroke engine, and show the time required, under like conditions, to heat the same quantity of water in the cooling tank of the same test bench. For equal power, the two-stroke engine requires a smaller radiator and less water than a four-stroke engine.

Scavenging the exhaust gases.- It is customary to say that a two-stroke engine consumes more fuel per horsepower-hour than a four-stroke engine. This is explained by the fact that a large portion of the energy is used in the preliminary compression of the fresh gases and it is impossible to keep them from escaping through the exhaust port. This question is primordial in aeronautics, since a large fuel consumption raises the cost and diminishes the radius of action. The comparison must naturally be made between engines which are similar from

the two viewpoints of the cylinder material and of the actual compression.

A very thorough study of this question has been made by a learned technician, Mr. Colmant, who sought to discover, first of all, just how the exhaust gases escaped and how the fresh gases entered the cylinder. He arrived at the conclusion that, as soon as the exhaust port was uncovered by the piston, the exhaust gases escaped from the cylinder at a velocity of 380-400 m (1247-1312 ft.) per second, creating behind them a relative vacuum of 0.4 kg/cm<sup>2</sup> (5.7 lb./sq.in.). Moreover, this vacuum is created instantaneously, even before the exhaust port is entirely uncovered. Thus, for an engine of 140 mm (5.51 in.) stroke, revolving at 2300 R.P.M., the exhaust takes place almost entirely through the top 4-5 mm (0.157-0.197 in.) of the port, although the port has a vertical diameter of 28 mm (1.1 in.). Consequently, the fresh gases can enter the cylinder as soon as the intake port is uncovered. It is important therefore that they should be compressed but very little beforehand, since otherwise they would have time, driven by the piston deflector, to make the tour of the cylinder and leave it before the closing of the exhaust valve. Too great a preliminary compression of the fresh gases, in addition to causing a useless waste of energy, results therefore in a loss of the gases themselves and in a consequent excessive fuel consumption per horsepower-hour.

It would seem to follow from the above, that it is an error to speak of the scavenging of the exhaust gases by the fresh gases. As to the stratification of the gases in the cylinder, it is impossible, in an airplane engine having pistons provided with a deflector and revolving at 1500-2500 R.P.M., to discover how the stratification is established and all the suppositions possible in this connection are absolutely gratuitous.

This question of fuel consumption combined with that of alimentation, distribution and exhaust has led to the construction of two-stroke engines differing more or less in their mechanical complications.

Intake.- It is evidently advantageous, for completely filling the cylinders, to draw in the carbureted gases during as long a period as possible, the transfusion of the gases being accomplished in every possible way during the period of opening of the intake port. The two curves in Fig. 4 show the variation in power resulting from the variation in filling due to the variation in the period of aspiration of the fresh gases into the preliminary-compression chamber. These two curves were derived from two six-cylinder airplane engines in V. In the first engine, the aspiration continued during the whole of the upward piston stroke of 150 mm (5.91 in.). In the second engine, the aspiration occurred during the last 30 mm (1.18 in.) of the stroke, the stroke, bore, theoretical compression in

the explosion chamber and in the preliminary-compression chamber being the same in both cases. The power was reduced about one-third. This aspiration, continued as long as possible, also has a great effect on the course of the power curve, principally at the relatively high revolution speeds (about 2000 R.P.M.) which must be maintained by an airplane engine, because incomplete filling, due to an insufficient intake period, is manifested; if not by a rapid descent in the power curve, at least by a prolonged horizontal line. This characteristic of the curve, formerly considered advantageous for an automobile engine, is a serious defect in an airplane engine, because it only diminishes the propeller efficiency for the same engine power. It also renders the engine, with propeller mounted, indifferent to the operation of the throttle and is the source of poor recovery ("pick-up").

Fuel consumption.- There is, moreover, occasion to remark that alimantation is not the only thing to affect the shape of the curve, since the distribution has at least as much effect. However, before examining the different methods of distribution employed on airplane engines, it is of interest to consider the results thus far obtained, from the viewpoint of fuel consumption per horsepower-hour.

The curves in Fig. 5 show the results obtained by Mr. Colmant. Note the fuel consumption, relatively small, obtained in

cast-iron cylinders with a compression ratio of only 4.6. These results were obtained by the successive construction of numerous engines, for which, while retaining the same methods of alimentation and distribution, Mr. Colmant proceeded to the analysis of the exhaust gases at their exit from the cylinder. By successive changes in the relative dimensions of the different elements of the cylinder, he succeeded in establishing empirical laws which render it possible to obtain the minimum fuel consumption, as shown by the absence of hydrocarbons in the exhaust gases. The following table contains the results of two analyses of gas from two engines of differing cylinders but the same cylinder capacity.

<u>Gas</u>	<u>1st analysis</u>	<u>2d analysis</u>
Carbon dioxide	9.01	12.22
" monoxide	0.19	0.08
Oxygen	2.00	1.92
Acetylene	traces	0.00
Hydrocarbons	3.04	0.81
Nitrogen (by difference)	85.76	84.97

The first analysis reveals the presence of carbureted gases, while the second shows only burnt gases. In the latter case, it has also been found that a portion of the burnt gases still remains in the cylinder. The burnt gases cannot be entirely expelled without losing some of the fresh gases, in which

case the increase in the fuel consumption per horsepower-hour more than offsets any gain in power.

Alimentation.- In the two-stroke airplane engines thus far constructed, the preliminary-compression chamber consists of:

1. The crankcase itself ("Messpa" and "Cicam" engines - Figs. 6-7), a solution presenting the disadvantage of mixing oil with the fresh gases, whence an excessive oil consumption, on the one hand, and faulty lubrication on the other, since the presence of gasoline in the oil impairs its lubricating qualities.
2. The lower part of the cylinder, whose bore is increased ("Laviator" engine, rotary or fixed - Fig. 8). The pump body, thus formed by the cylinder walls, on the one hand, and the piston with a double bore, on the other, may be made to have a zero clearance, if the constructor considers it necessary, and is in every way at his entire disposal by the variation of the length of the piston, which has a small bore with relation to its stroke.
3. A space of variable volume limited by a fixed partition between the cylinder and the crankcase and by the lower face of the piston ("C.F.A." engine, "Colmant" type.- Fig. 9).

The last two methods present, as regards lubrication (which is always one of the elements essential to the life of

an engine) the very great advantage of excluding the connecting rods from the explosion chamber. The lubrication of the cylinders is effected by an oil distributor delivering directly to each cylinder the requisite quantity of oil, which lubricates the walls, burns and is then expelled in the exhaust. None of the burnt oil returns to the crankcase. We thus obtain, with a small oil consumption, the advantage of always lubricating the revolving parts with fresh oil.

In recent engines, according to the type of compression chamber adopted, the constructors have reserved very variable clearances for the intake pumps, so that the gases are given very different compressions. The order of magnitude of this preliminary- compression seems therefore to be still quite unsettled and its optimum value for obtaining the greatest thermal efficiency (a value, moreover, which is evidently variable with the revolution speed and the shape of the cylinder and piston) has not yet been fixed.

On the other hand, whatever method of distribution is adopted, the intake pipe *a*, in a two-stroke engine, has a much greater effect than in a four-stroke engine, on the filling of the cylinders and, consequently, on the best utilization of the engines. With a very rough or narrow pipe, the top of the power curve is reached at a relatively low revolution speed. Fig. 10 gives the curves for two engines of the same type and approximately the same cylinder capacity. In one of them, how-

ever, the intake ports have been slightly reduced.

Distribution.- The different distribution methods, adopted for two-stroke engines, all depend on the two following principles:

- a) The admission into the compression chamber must cover as long a period as possible;
- b) The distributor must secure for the gases the widest possible passage, while avoiding all stratification and all loss of charge.

Consequently, the admission into the compression chamber always begins, as soon as the piston, during its ascent, starts to open the intake port into the cylinder. The admission of the fresh gases into the compression chamber may begin even before the cylinder intake port is completely closed.

A test showed no variation in the fuel consumption nor in the power. No disadvantages need therefore be feared if it becomes necessary, in order to increase the intake period, to place the cylinder, for a very brief instant, in direct communication with the carburetor.

On the other hand, the retard in the closing of the intake port (which varies for each engine type and according to the method of distribution) reaches its maximum just as the excess is indicated by a back flow of carbureted gases to the carburetor. For example, in a six-cylinder airplane engine having

a stroke of 150 mm (5.91 in.), no change was noted when the retard in closing the intake port passed from 10 to 16 mm (0.394 to 0.63 in.). The three solutions under consideration are the rotary distributor (Fig. 11), the piston valve (Fig. 12) and the sleeve (Fig. 13).

The rotary distributor was employed on both the rotary and fixed Laviator engine. This distributor puts the carburetor in successive communication with the compression chambers, through the medium of the central portion of the crankshaft, each compression chamber supplying the preceding cylinder.

In the three-cylinder rotary engine, the distributor rotates at the same speed as the engine. It has three ports, at 120° intervals, which pass successively in front of the port reserved in the crankshaft. The period of opening of this rotary valve, thus putting the carburetor and compression chamber into communication, coincides with the ascending stroke of the piston. The closing occurs during the descending stroke with a retard of 6 mm (0.236 in.), the whole stroke being 150 mm (5.91 in.).

On this engine, as on all those having a rotary distribution valve, the maximum power is reached at a relatively low revolution speed (about 1400 R.P.M.). This maximum is followed, if not by a horizontal line, at least by a curve which seems to indicate that the alimentation of the cylinders is not so good above this speed. The loss in charge is really consider-

able, due to a right-angle turn made by the fresh gases in passing from the intake port of the compression chamber. Furthermore, since the opening of this port is effected by a uniform circular motion, the time allowed for the fresh gases to pass, depends only on the ratio of the width of the port to the diameter of the distributor and is therefore limited.

On the contrary, in the case of a piston-valve or a sleeve with an alternating motion, the time does not depend simply on the size of the port, but also on the location of the port with respect to the top and bottom dead centers of the distributor.

For a straight engine, the rotary distributor, which must be about as long as the engine, introduces considerable friction, which is all the greater due to the need of tightness. Consequently, it wears rapidly, unless very well lubricated.

The piston-valve, operating like the slide-valve of a steam engine, is employed as a distributor on the Colmant engine (Figs. 16-17) built by the "Compagnie Francaise Aéronautique." It is actuated by a connecting rod driven by an eccentric shaft rotating at the speed of the engine. The retard of the slide-valve on the engine piston is about  $180^{\circ}$ . This small piston first uncovers the intake port and thus enables the alimentation of the compression chamber and then shuts off the carburetor from this chamber, which it makes air-tight, thus enabling the preliminary compression of the gases. The gases

are forced into the engine cylinder, through the intake port which is uncovered by the engine piston, by the preliminary compression produced by this piston. This compression is regulated structurally by the clearance of the lateral chamber, which forms the upper part of the cylinder of the piston-valve. The latter functions simply as a shutter, the preliminary compression being small. Neither it nor the bearings of the eccentric shaft which controls it are subjected to any stress. It is in no wise comparable, therefore, from the fatigue viewpoint, with the camshaft of a four-stroke engine. The piston is perforated on its lateral surface (distributor side). Consequently the gases encounter no appreciable resistance to their entrance into the compression chamber and, even at high revolution speeds, the charging is always good and the losses of charge are very small.

This advantage, moreover, is shared by the sleeve method and these two systems present, in comparison with the distribution by rotary valve, the possibility of obtaining a longer period of intake into the compression chamber.

The piston distributor and the sleeve have, in fact, an alternating motion and pass through a zero speed at the top and bottom dead centers of their strokes. If the center of the intake port coincides with the middle of the course of the upper part of the piston, it is easily seen that it thus has a longer period of opening than in any other position it could

occupy. The intake occurs, therefore, under the best possible conditions, its period being longer than for any other method of distribution. This explains why two-stroke engines, provided with the piston-valve or sleeve, have more definite maximum power curves than the others, a characteristic which manifests itself in better "pick-ups" and a greater responsiveness to the throttle.

Distribution by sleeve (Fig. 13) has been given several forms in two-stroke engines. The cylindrical sleeve, moving either in an engine cylinder or in a concentric cylinder, alternately uncovers the exhaust ports and the intake ports. Some constructors have even utilized two sleeves, one for the alimentation of the compression chamber and the other for the transfusion into the cylinder and exhaust. This solution is disadvantageous for an airplane engine, due to its weight, the greater complexity of the controls necessitated by it and the greater number of parts involved. In other words, it causes the two-stroke engine to lose the qualities of simplicity to which it owes its length of life, its reliability and its low cost.

In general, a single sleeve, having an alternate rectilinear or spiral motion and carrying an intake port in its upper part and an exhaust port in its lower part, uncovers almost simultaneously, near its bottom dead center, the ports leading to the compression chamber and to the exhaust chamber. The

ports can be so located that the exhaust port will be closed a few degrees before the intake port.

Consequently, this device presents, in the two preceding methods of distribution, a greater facility for avoiding loss of fresh gases in the exhaust. Some constructors have made the sleeve in such a way that the exhaust port is almost closed at the time the intake port opens, the partial vacuum created by the exit of the gases affording room enough for the fresh gases. In any case, the best adjustment between the opening of the intake port and the closing of the exhaust port, for a cylinder of given dimensions, can only be empirically established by the analysis of the exhaust gases for different sleeves.

The sleeve method of distribution is therefore very attractive, because it presents the possibility of obtaining a better fuel consumption. The constructor has at his disposal, in fact, two movable parts, the piston and the sleeve, for closing the exhaust port before the exhaust gases reach it, while this can be effected only by the piston in the other methods of distribution.

Its mechanical execution, however, presents a small obstacle, namely, the guiding lug of the sleeve. This difficulty has, however, been overcome, either by the use of two diametrically opposite lugs or by the use of sleeves of babbitted steel instead of cast iron. The connecting rods controlling

this distribution are mounted on a crankshaft or on an eccentric shaft revolving at the speed of the engine. Their stroke differs from that of the piston-engine, to the fifth of this stroke, according to the constructor. It is manifestly important to reduce this as much as possible.

This mode of distribution, although giving the constructor more latitude than the preceding methods for regulating the intake and exhaust, involves, however, a greater complexity and a higher cost of construction. It localizes the summit of the power curve, on the other hand, to the vicinity of 1500-2000 R.P.M.

Sleeve distribution has been adopted on the "Gregoire" engine now being built.

Carburetion.- Although the problem of alimentation is much more complex on a two-stroke than on a four-stroke engine, the preparation of the carbureted mixture requires very little attention, because this mixture does not pass directly into the cylinder. It is first introduced into the compression chamber, where it is violently agitated, the gasification of the fuel being effected more completely than in the carburetor. On the other hand, the upper portion of the compression chamber consisting generally of the engine piston, the gases are perfectly heated in it. It is evidently difficult to discover what occurs in the compression chamber, but the trial, on a

like engine, of modern carburetors of different types, has given results analogous to the results obtained by using the most rudimentary carburetor. The carburetor of a two-stroke engine is a fuel distributor which sends the requisite quantities of air and fuel into the compression chamber. The essential thing is not to have sharp bends in the intake pipes. Consequently, a constant level carburetor is, in some cases, difficult to install, by reason of the bends which have to be given the pipes between the carburetor and the intake ports.

Especially on a V-engine, the intake at the center (through a carburetor located either at one end or at the center) does not work well, since the stream of gases issuing from the carburetor must make an angle of at least  $90^\circ$  in order to reach the intake pipes. The "Tampier" block-tube, on the contrary, seems to allow the least loss of charge for any possible position of the intake pipe.

Idling speed.- Another peculiarity clearly distinguishes a two-stroke from a four-stroke engine, namely, the idling speed or, rather, the impression on the ear produced by the idling speed. While in a four-stroke engine, the regularity of the sound produced by idling increases with the number of cylinders, the case is quite different in a two-stroke engine, although the tachometer indications are very much the same in the two cases. Thus a 6-cylinder, 150 HP., two-stroke airplane

engine has a regular idling speed, without misfires, at 600 R.P.M. The revolution speed can be further reduced to and maintained at 300-400 R.P.M. (the tachometer reading remaining constant), but the noise becomes very irregular, a succession of misfires producing a very disagreeable effect on the car. This is probably explained as follows: The linear speed of the piston being low, the exhaust port is closed slowly. The result is that the exhaust gases (which, on expanding violently at the opening of this port, produce a partial vacuum behind them) have time to be sucked back into the cylinder before the port closes. These gases having become mixed with pure air, the result is that the cylinders occasionally contain too much inert gas in proportion to the fresh carbureted gas, thereby producing poor explosions or misfires. It is fortunate, however, that this phenomenon is produced, since otherwise, if each cylinder exploded regularly in its turn and gave the corresponding impulse to the crankshaft, the minimum revolution speed could be established only at a relatively high R.P.M.

The process of filling the cylinders of a two-stroke engine is, in fact, entirely different from that of a four-stroke engine running at the same revolution speed. In a four-stroke engine running with its carburetor entirely closed (which corresponds to extreme idling speed), the compression in the chamber is very low at the time of the explosion, so that only a feeble impulsion is communicated to the crankshaft. On a

two-stroke engine, the compression at the corresponding moment is greater when the cylinder has been partly charged, at the bottom dead center, with a large proportion of hot exhaust gases, so that a violent impulse is communicated to the crankshaft by the exploding cylinder. On the other hand, the cylinders which fail to explode, because of the presence of too great a proportion of exhaust gases, act as brakes during their compression strokes. Their action therefore counteracts the impulse given the crankshaft by the explosions and it is the sum of these opposing phenomena which renders the idling speed possible. Each cylinder acts some of the time as an engine, and some of the time as a brake, according to how it happens to be charged. The result is that the larger the number of cylinders in a two-stroke engine, the more irregular (for a given revolution speed) the sound of the idling speed becomes. This disadvantage (which can be only slightly ameliorated by a muffler and which renders the use of a two-stroke engine impossible on a vehicle "de luxe") seems to be slight on an airplane. Thus a mean minimum idling speed is obtained, the majority of the cylinders which do not ignite acting as brakes to the one or two cylinders which do ignite.

Ignition.- The ignition problem is rendered difficult by the high speeds at which the magnetos must revolve, especially for polycylinder engines with double ignition. Thus the double

ignition of an 8-cylinder airplane engine can be accomplished with two magnetos, only by using stationary-armature magnetos revolving at twice the speed of the engine (about 4000 R.P.M.). The use of simple magnetos would necessitate a revolution number twice the above, which is absolutely prohibitive.

#### Principal Two-Stroke Engines Built in France

The Laviator engine was the first two-stroke airplane engine built and the first one to make an airplane fly. It was first made with three rotary cylinders (130 x 130 mm - 4.72 x 5.12 in.) and then with six rotary cylinders. The definitive engine is a fixed type with six radial cylinders having a bore of 100 mm (3.94 in.) and a stroke of 150 mm (5.91 in.). Fig. 15 gives the curves for the two 6-cylinder engines.

The low efficiency of the rotary engine was due to the fact that, since the exhaust ports were in the lower part of the cylinders, the exhaust gases could not leave, but were thrown into the tops of the cylinders by the centrifugal force.

The fixed water-cooled engine, with the same system of alimentation and distribution, had a fuel consumption of about 350 grams (12.35 ounces) per HP./hr. This excessive fuel consumption was due, in part, to the small compression ratio (approximately 3.5) in the explosion chamber, and in part to the excessive compression of the fresh gases in the preliminary compression chamber, where the clearance was necessarily very

small. A large portion of the fresh gases was consequently lost in the exhaust. The engine weighs 135 kg (297.6 lb.). It has not been subjected to any endurance test.

The C.F.A. engine.- The engine of the "Compagnie Française Aéronautique" is a 6-cylinder V-engine, 106 x 150 mm (4.17 x 5.91 in.), of the Colmant type (Fig. 16). Each bank of cylinders consists of a block of cast aluminum, with one valve for each cylinder, which has a steel liner designed to assure the friction of the piston rings on the wall. The pistons are aluminum, as likewise the piston rods and their guides. The tightness of the preliminary-compression chamber is assured by a large ring on the central piston rod. The crankshaft has four bearings and three sets of connecting rods, each set hinged to a sleeve having one connecting rod babbitted internally and pivoting on the crank-pin, the other connecting rod, outside the first, being connected with it by a ring of phosphorus bronze. The piston valves are operated by eccentric shafts, the connecting rods being aluminum. They serve simply as guides and are subjected to no appreciable stress. The double ignition is assured by two stationary armature S.E.V. magnetos. About 140 HP. is developed at 1800 R.P.M. for a weight of 170 kg (375 lb.).

The Gregory engine, now under test, has a sleeve distributor for each cylinder. It has 8 cylinders in V, 120 HP., a

a fuel consumption of 270 grams (9.52 ounces) per horsepower-hour. It generates about 20 HP. per liter of cylinder capacity at 1500 R.P.M., which is very remarkable.

Future of the two-stroke-cycle engine.-- It would seem that the thermodynamics of the two-stroke engine has now advanced far enough to enable the construction of engines of this type having a fuel consumption, per HP./hr., of the same order of magnitude as that of a four-stroke engine, the only complaint hitherto made against this type of engine having been thus eliminated.

The various tests, now in process, some of which, relative to endurance, have been encouraging, render it possible to anticipate the construction, within a short time, of two-stroke airplane engines more durable and reliable than the present four-stroke engines: more durable, because their parts will work under less fatiguing stresses; more reliable, because the number of engine parts will be fewer for the same power. It is only by seeking simplicity of structure that the maximum reliability and efficiency will be most directly attained.

Translation by Dwight M. Miner,  
National Advisory Committee  
for Aeronautics.

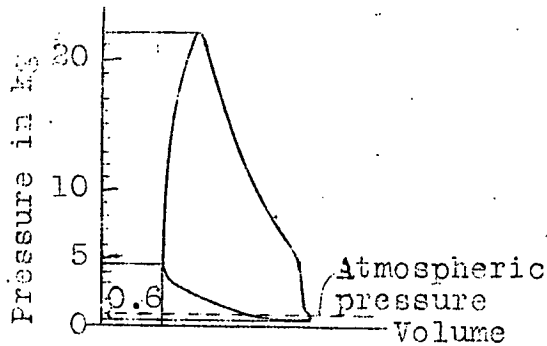

Fig. 1. Indicator diagram for the explosion chamber of a two-stroke-cycle engine.-Although the theoretical compression ratio is 4.6, the maximum explosion pressure is only 22 kg/cm<sup>2</sup> (313 lb./sq. in.), instead of 26 kg/cm<sup>2</sup> (370 lb./sq.in.) for a four-stroke engine having the same compression ratio.

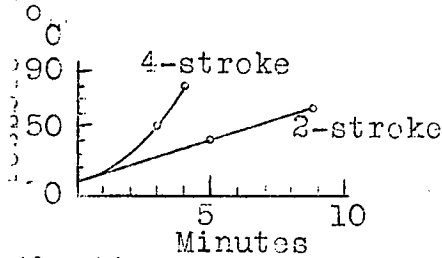

Fig. 2. Curves showing the time required to heat the same quantity of water by circulation in a two-stroke and in a four-stroke engine of the same power. It is manifest that the two-stroke engine heats less than the four-stroke.

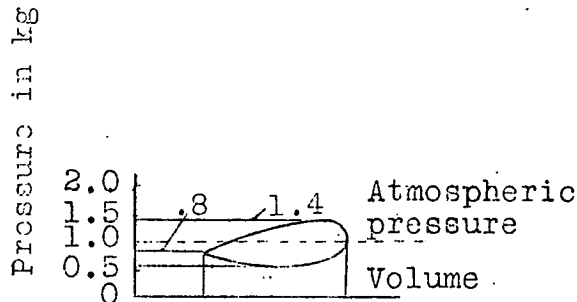

Fig. 3. Indicator diagram for the compression chamber of a two-stroke engine.- Note the small preliminary-compression ratio of 1.4, which enables a low fuel consumption.

Fig.4. Effect of length of intake period on the engine power.-Curve I is for a two-stroke engine in which the intake continues during the whole piston stroke of 150 mm (5.91 in.), this long period being rendered possible by a distributor. Curve II is for an engine without a distributor, in which, consequently, the intake can occur only toward the end of the stroke, in the present instance during only the last 30 mm(1.18 in.), the power being less, especially at high revolution speeds.

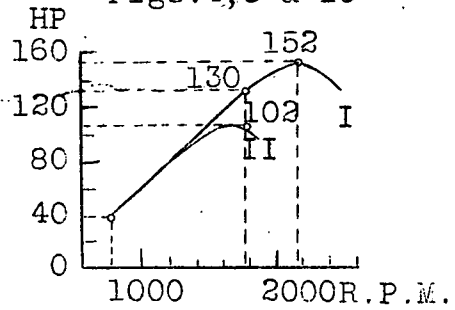

Fig.5. Curves of power and fuel consumption for a two-stroke engine having a cylinder capacity of 3.5 liters(213.5 cu.in.).- Note the pointed summit of the power curve, characteristic of an engine with a good "pick-up", and the rectilinear course of the fuel-consumption curve, which is manifested by the proportionality of the total fuel consumption to the number of horsepower furnished.

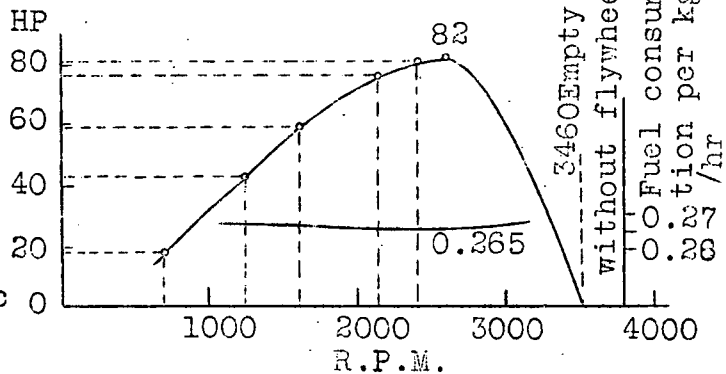
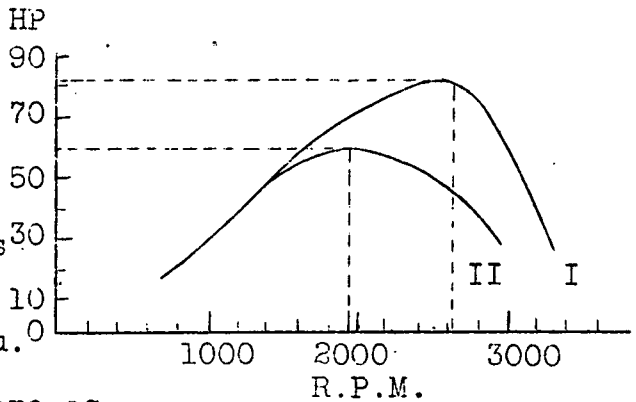

Fig.10. Effect of size of intake ports on power curve.- Curves I and II are for two two-stroke engines with four cylinders in a row and a cylinder capacity of 3.5 liters(213.5 cu.in.). In the first engine, the ports are as large as the cylinder dimensions allow. In the second engine, the ports were reduced about one-third, so as to obtain the maximum power for 2000 R.P.M. The divergence of the curves shows that the effect of the size of the intake ports on the power is much greater than in a four-stroke engine.



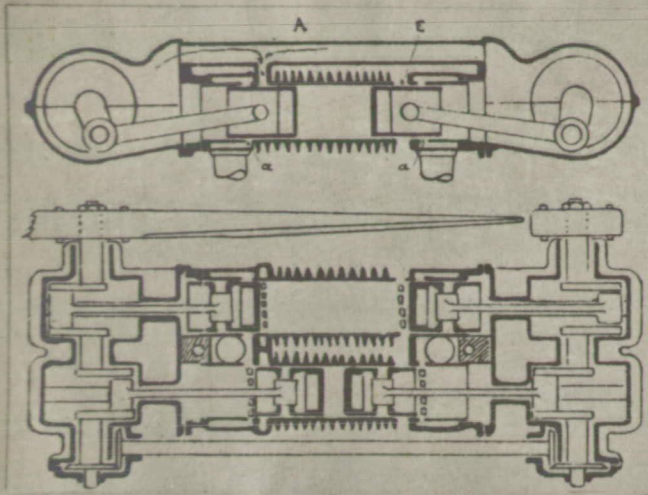

Fig.6 Messpa engine.- This is one of the rare two-stroke airplane engines built about 1912. In this engine, the gases pass through the ports a into the crankcase and thence, after compression, through A into the cylinders. E is the exhaust port. The engine drives two propellers at right angles to each other.

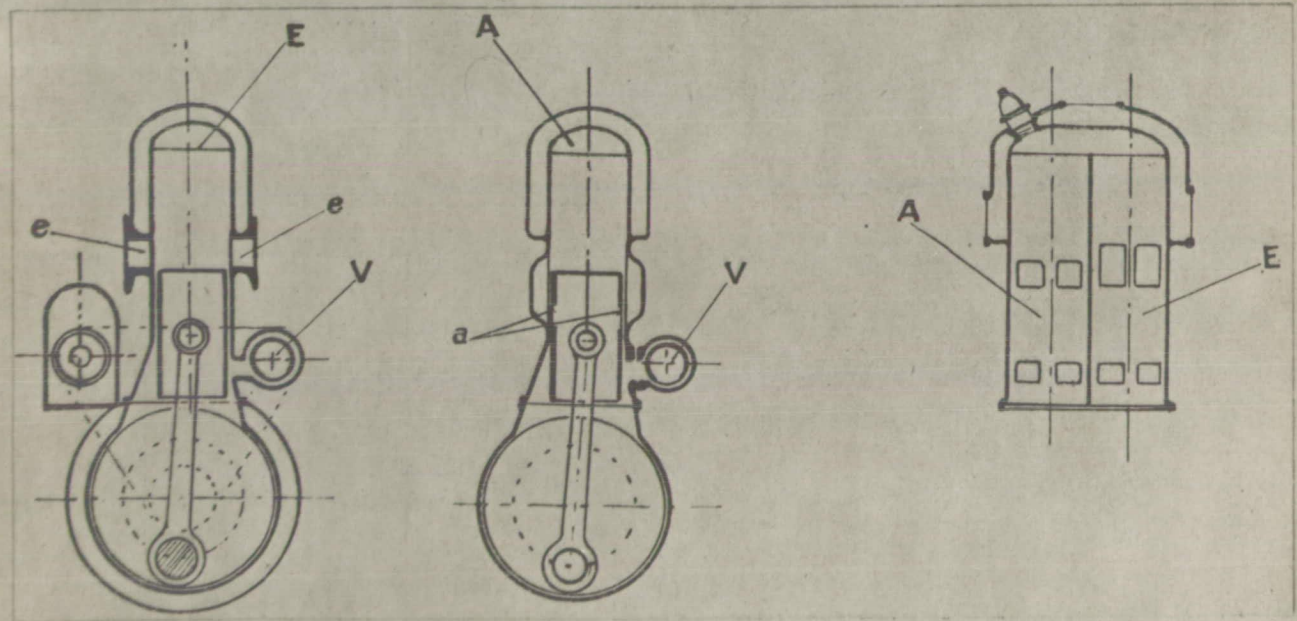

Fig.7 C.I.C.A.M. engine.- This engine was built toward 1923 and used on a light airplane. It has two cylinders inclosed in the same water jacket and communicating at their tops. The cylinder E carries the exhaust ports and A the intake ports placed in communication with the carbureter by a rotary valve V. The gases pass through V into the common crankcase, where they are compressed and whence they are forced into A through the ports a. Simultaneously the exhaust gases leave E through the ports e, the communicating passage between the tops of these cylinders being narrow enough to play the role of a piston deflector. In effect, it is therefore a one-cylinder engine, having a low fuel consumption but a complicated design.

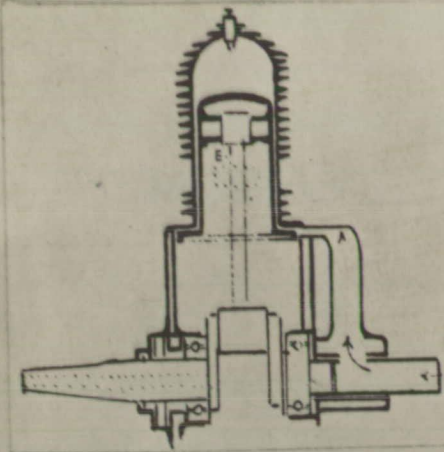

Fig. 8 The Laviator engine.-

This was first built as a rotary engine, but was not a success. It was then built as a fixed engine and was installed on a Sommer airplane before the war. The crankshaft forms a rotary valve and causes the carburetor to communicate successively with the compression chambers C, which have a double bore. Each compression chamber works for a neighboring cylinder.

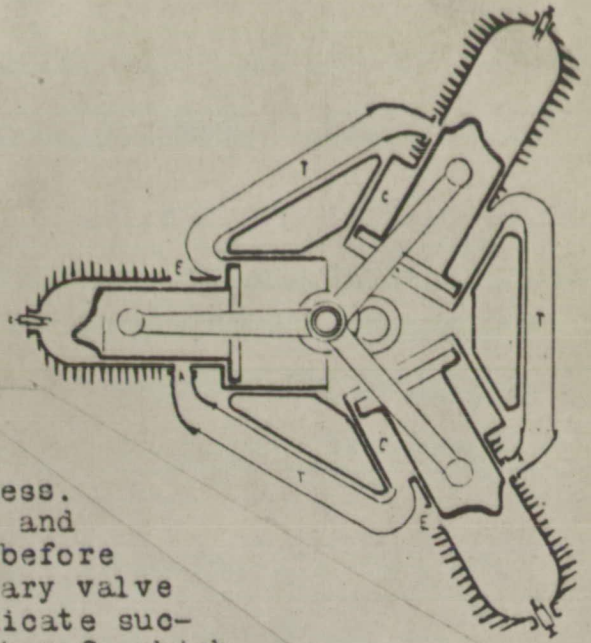
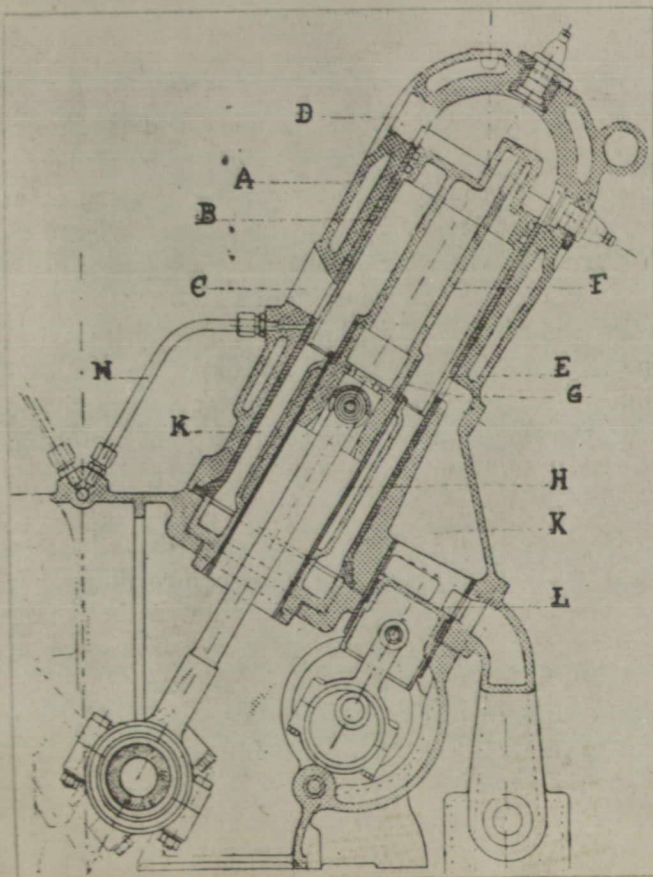
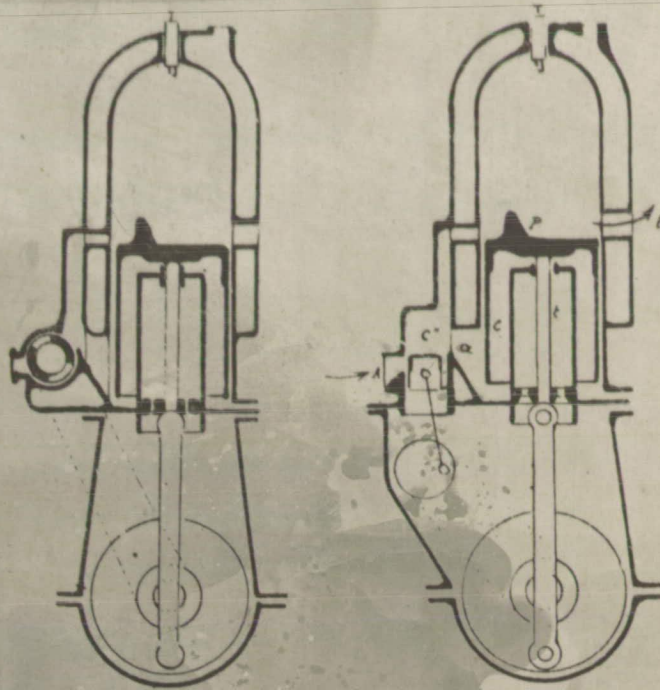

Fig. 9 C.F.A. engine, Colmant type.

A, aluminum cylinder-head; B, tubular jacket of soft steel; C, exhaust port; D, connection for starter; E, cylinder intake port; F, aluminum piston; G, piston-ring for compression chamber; H, steel liner of crosshead guide; K, compression chamber; L, piston valve; N, oil distributor for lubricating the cylinder.

It is a 6 - cylinder V engine, having a cylinder capacity of 7 liters (427 cu.in.) and generating 150 HP at about 2300 R.P.M.





Figs.11-12. Two distribution methods.- On the left, by rotary valve, on the right, by piston-valve.

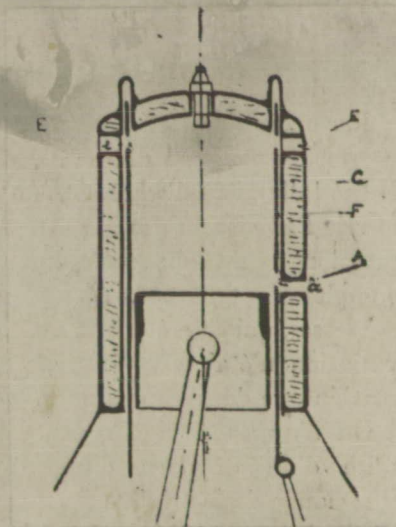

Fig.13. Distribution by a single sleeve.-A sleeve F, carrying two exhaust valves E and one intake valve A, on the preliminary-compression chamber, has an alternating motion. The ports, which it carries, thus coincide with the ports e and a reserved in the cylinder C, thus enabling the exhaust and intake. This sleeve is driven by a connecting-rod, mounted on a crankshaft whose stroke is only a fraction of that of the engine crankshaft. Some constructors have added a second sleeve, concentric to the first, which enables the closing of the exhaust port before the intake port. Other engines have imparted a spiral motion to a single sleeve for the same purpose.

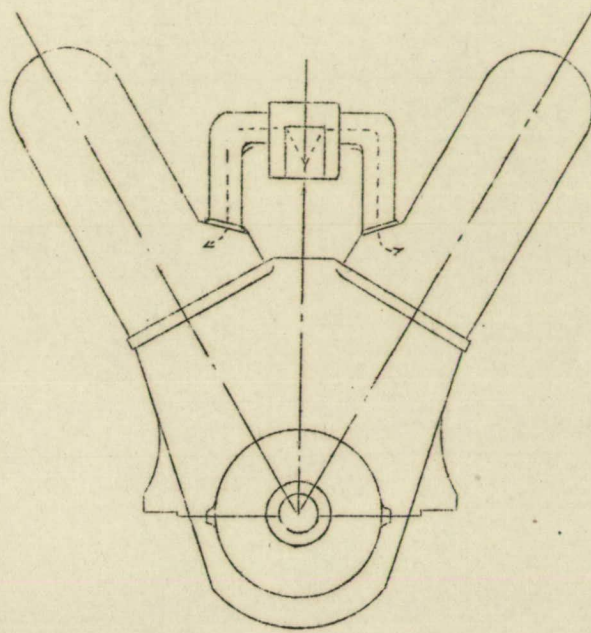

Fig.14. Alimentation of a two-stroke V-engine by a central float-carbureter.- The path of the fresh gases, from the carbureter to the preliminary-compression chambers, is indicated by the dotted lines. Note the unavoidable bends in the intake pipes, which render this device impracticable.

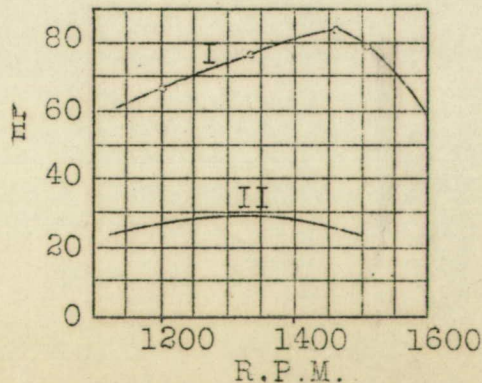

Fig.15. Power curves of the Laviator engines.- I, fixed; II, rotary.

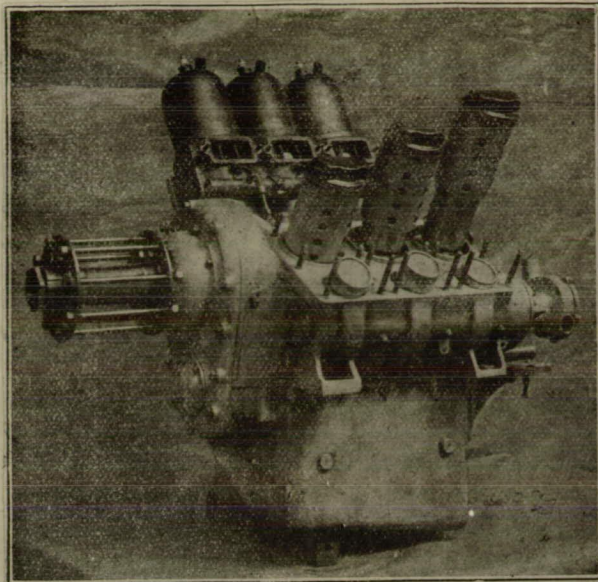

Fig.16 Photograph of the Colmant engine.- This engine was built in 1916. It underwent an endurance test of 316 hours at 1800 R.P.M. Its power at this speed is about 130 HP, the number of revolutions of the propeller shaft being about 1200 R.P.M. Its weight, in running order, is 230 kg(507 lb.). The cylinders of the left bank have been raised, thus making it possible to see clearly the method of guiding the engine pistons and the distributor pistons. The 140 HP C.F.A. engine was derived from the Colmant engine by different methods of construction, enabling a lightening of the engine, the general dimensions remaining unchanged.

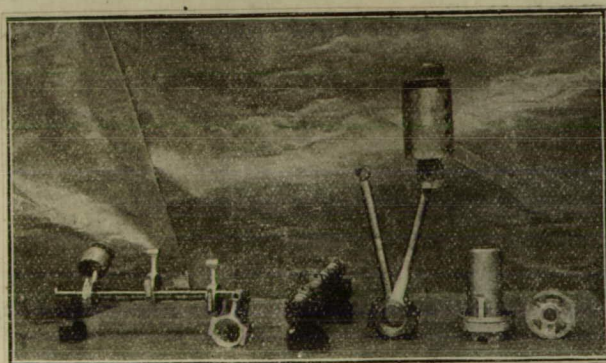

Fig.17. Photograph of detached parts of the C.F.A. engine.- From left to right: eccentric shafts, piston-rod connecting-rods, piston-valve, connecting-rod, engine piston, crosshead-guide of piston and bearing of the eccentric shaft.