

**NATIONAL ADVISORY COMMITTEE
FOR AERONAUTICS**



REPORT No. 436

c-3

**TESTS OF NACELLE-PROPELLER COMBINATIONS IN
VARIOUS POSITIONS WITH REFERENCE TO WINGS**

**II—THICK WING—VARIOUS RADIAL-ENGINE
COWLINGS—TRACTOR PROPELLER**

By DONALD H. WOOD



1932

AERONAUTICAL SYMBOLS

1. FUNDAMENTAL AND DERIVED UNITS

	Symbol	Metric		English	
		Unit	Symbol	Unit	Symbol
Length.....	<i>l</i>	meter.....	m	foot (or mile).....	ft. (or mi.)
Time.....	<i>t</i>	second.....	s	second (or hour).....	sec. (or hr.)
Force.....	<i>F</i>	weight of one kilogram.....	kg	weight of one pound.....	lb.
Power.....	<i>P</i>	kg/m/s.....	k. p. h.	horsepower.....	hp
Speed.....		{ km/h.....		{ m. p. s.	{ mi./hr.
		{ m/s.....		{ ft./sec.	{ f. p. s.

2. GENERAL SYMBOLS, ETC.

<i>W</i> , Weight = mg	mk^2 , Moment of inertia (indicate axis of the radius of gyration k , by proper subscript).
g , Standard acceleration of gravity = 9.80665 m/s ² = 32.1740 ft./sec. ²	
m , Mass = $\frac{W}{g}$	S , Area.
ρ , Density (mass per unit volume).	S_w , Wing area, etc.
Standard density of dry air, 0.12497 (kg-m ⁻⁴ s ²) at 15° C. and 750 mm = 0.002378 (lb.-ft. ⁻⁴ sec. ²).	G , Gap.
Specific weight of "standard" air, 1.2255 kg/m ³ = 0.07651 lb./ft. ³ .	b , Span.
	c , Chord.
	$\frac{b^2}{S}$, Aspect ratio.
	μ , Coefficient of viscosity.

3. AERODYNAMICAL SYMBOLS

V , True air speed.	Q , Resultant moment.
q , Dynamic (or impact) pressure = $\frac{1}{2} \rho V^2$.	Ω , Resultant angular velocity.
L , Lift, absolute coefficient $C_L = \frac{L}{qS}$	$\rho \frac{Vl}{u}$, Reynolds Number, where l is a linear dimension.
D , Drag, absolute coefficient $C_D = \frac{D}{qS}$	e. g., for a model airfoil 3 in. chord, 100 mi./hr. normal pressure, at 15° C., the corresponding number is 234,000;
D_o , Profile drag, absolute coefficient $C_{D_o} = \frac{D_o}{qS}$	or for a model of 10 cm chord 40 m/s, the corresponding number is 274,000.
D_i , Induced drag, absolute coefficient $C_{D_i} = \frac{D_i}{qS}$	C_p , Center of pressure coefficient (ratio of distance of <i>c. p.</i> from leading edge to chord length).
D_p , Parasite drag, absolute coefficient $C_{D_p} = \frac{D_p}{qS}$	α , Angle of attack.
C , Cross-wind force, absolute coefficient $C_C = \frac{C}{qS}$	ϵ , Angle of downwash.
R , Resultant force.	α_o , Angle of attack, infinite aspect ratio.
i_w , Angle of setting of wings (relative to thrust line).	α_i , Angle of attack, induced.
i_s , Angle of stabilizer setting (relative to thrust line).	α_a , Angle of attack, absolute. (Measured from zero lift position.)
	γ , Flight path angle.

REPORT No. 436

**TESTS OF NACELLE-PROPELLER COMBINATIONS IN
VARIOUS POSITIONS WITH REFERENCE TO WINGS**

**II—THICK WING—VARIOUS RADIAL-ENGINE
COWLINGS—TRACTOR PROPELLER**

By **DONALD H. WOOD**
Langley Memorial Aeronautical Laboratory

NATIONAL ADVISORY COMMITTEE FOR AERONAUTICS

NAVY BUILDING, WASHINGTON, D. C.

(An independent Government establishment, created by act of Congress approved March 3, 1915, for the supervision and direction of the scientific study of the problems of flight. Its membership was increased to 15 by act approved March 2, 1929 (Public, No. 908, 70th Congress). It consists of members who are appointed by the President, all of whom serve as such without compensation.)

JOSEPH S. AMES, Ph. D., *Chairman*,
President, Johns Hopkins University, Baltimore, Md.
DAVID W. TAYLOR, D. Eng., *Vice Chairman*,
Washington, D. C.
CHARLES G. ABBOT, Sc. D.,
Secretary, Smithsonian Institution, Washington, D. C.
GEORGE K. BURGESS, Sc. D.,
Director, Bureau of Standards, Washington, D. C.
ARTHUR B. COOK, Captain, United States Navy,
Assistant Chief, Bureau of Aeronautics, Navy Department, Washington, D. C.
WILLIAM F. DURAND, Ph. D.,
Professor Emeritus of Mechanical Engineering, Stanford University, California.
BENJAMIN D. FOULLOIS, Major General, United States Army,
Chief of Air Corps, War Department, Washington, D. C.
HARRY F. GUGGENHEIM, M. A.,
The American Ambassador, Habana, Cuba.
CHARLES A. LINDBERGH, LL. D.,
New York City.
WILLIAM P. MACCRACKEN, Jr., Ph. B.,
Washington, D. C.
CHARLES F. MARVIN, M. E.,
Chief, United States Weather Bureau, Washington, D. C.
WILLIAM A. MOFFETT, Rear Admiral, United States Navy,
Chief, Bureau of Aeronautics, Navy Department, Washington, D. C.
HENRY C. PRATT, Brigadier General, United States Army,
Chief, Matériel Division, Air Corps, Wright Field, Dayton, Ohio.
EDWARD P. WARNER, M. S.,
Editor "Aviation," New York City.
ORVILLE WRIGHT, Sc. D.,
Dayton, Ohio.

GEORGE W. LEWIS, *Director of Aeronautical Research*.

JOHN F. VICTORY, *Secretary*.

HENRY J. E. REID, *Engineer in Charge, Langley Memorial Aeronautical Laboratory, Langley Field, Va.*

JOHN J. IDE, *Technical Assistant in Europe, Paris, France.*

EXECUTIVE COMMITTEE

JOSEPH S. AMES, *Chairman*.

DAVID W. TAYLOR, *Vice Chairman*.

CHARLES G. ABBOT.

GEORGE K. BURGESS.

ARTHUR B. COOK.

BENJAMIN D. FOULLOIS.

CHARLES A. LINDBERGH.

WILLIAM P. MACCRACKEN, Jr.

CHARLES F. MARVIN.

WILLIAM A. MOFFETT.

HENRY C. PRATT.

EDWARD P. WARNER.

ORVILLE WRIGHT.

JOHN F. VICTORY, *Secretary*.

REPORT No. 436

TESTS OF NACELLE-PROPELLER COMBINATIONS IN VARIOUS POSITIONS WITH REFERENCE TO WINGS. II.—THICK WING—VARIOUS RADIAL-ENGINE COWLINGS—TRACTOR PROPELLER

By DONALD H. WOOD

SUMMARY

This report is the second of a series giving the results obtained in the 20-foot wind tunnel of the National Advisory Committee for Aeronautics on the interference drag and propulsive efficiency of nacelle-propeller-wing combinations. The first report gave the results of the tests of an N. A. C. A. cowled air-cooled engine nacelle located in 21 positions with reference to a thick wing. The present report gives results of tests of a normal engine nacelle with several types of cowling and fairings in four of the positions with reference to the same wing.

The wing had a 5-foot chord, a 15-foot span, and a maximum thickness of 20 per cent of the chord. The engine was a 4/9-scale model of a Wright J-5 radial air-cooled engine, and was installed in a small nacelle of the same scale. Tests were made with no engine cowling, with a narrow variable-angle ring, two wide thin rings with different chord angles, and the hood previously used on the N. A. C. A. cowled nacelle. The propeller was a 4-foot diameter model of the standard Navy adjustable-pitch metal propeller No. 4412.

In two of the nacelle positions tests were made in two conditions—with the nacelle supported on struts and with the space between the nacelle and wing filled by fairing. The effects of fairing the N. A. C. A. hood into the wing and of side brackets on the nacelle when located ahead of the wing were also investigated.

The lift, drag, and propulsive efficiency were determined at several angles of attack for each cowling and fairing condition in each of the four nacelle locations. The net efficiency was computed by the method of Report No. 415 and compared with the results therein reported.

Although the propulsive efficiency of the small uncowed nacelle is higher than that of the nacelle with any of the cowlings, the drag and interference are also higher, and the highest net efficiency is obtained with the N. A. C. A. cowled nacelle. Fairing the nacelle into the wing is an advantage when the cowled nacelles are located near the wing but is of little value when the nacelles are not cowled. Fairing the N. A. C. A. hood into the wing is detrimental. Side brackets on the nacelle when it is located ahead of

the wing are to be avoided. The N. A. C. A. cowled nacelle located about 25 per cent of the chord ahead of the wing is the best tractor-nacelle arrangement. If the cowling is omitted with nacelle in this position, a loss of lift results, especially at high angles of attack. The proper location of nacelles and careful cowling are important in the high-speed range of flight, but in the lower speed ranges there is little advantage of one nacelle position or cowling over another.

INTRODUCTION

This report is the second of a series giving the results of a general investigation of the mutual effects of wings, nacelles, and propellers. Originally presented at the Fourth Annual Aircraft Engineering Research Conference in May, 1929, the program has been subsequently extended and now includes tractor, pusher, and tandem propellers, and biplane as well as monoplane wings. Several propeller pitch settings and numerous types of engine cowling have also been included.

The first report (reference 1) gave the results obtained with an N. A. C. A. cowled air-cooled engine nacelle located in 21 positions with reference to a thick monoplane wing. The results indicated that a position of the nacelle directly ahead of the wing was the best. If practical considerations demand less favorable locations, the nacelles should not be placed too close to the wing above or below. The use of cowlings on radial air-cooled engines has been uniformly successful. Many installations, however, have been, and probably will continue to be made without cowling over the engine, or at least with simpler forms of cowling. That cowling is an advantage is a sufficient reason for making the extensive series of tests of reference 1; but it is also important to know something of the effects when the engine is not cowled or is fitted with other forms of cowling.

This second report in the series therefore presents the results obtained with an engine nacelle of the type commonly used with uncowed engines. This nacelle was tested both uncowed and with four cowlings which experience and a study of existing airplane designs indicated were most efficient or were in common use.

Four nacelle positions were selected from the original series—the position ahead of the wing which the first tests had shown to be the best and three others, one above and forward of the wing and two below the

and because of other design restrictions. Other locations away from the wing may be slightly better, but it is hardly worth while using them except in special cases. In each nacelle position the four types of cowl-

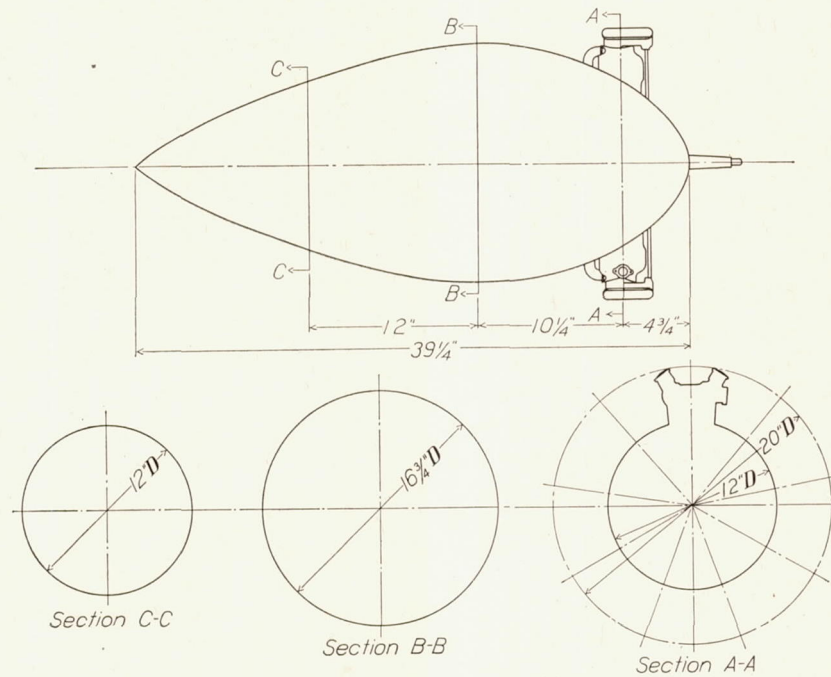

FIGURE 1.—Small nacelle and engine assembly

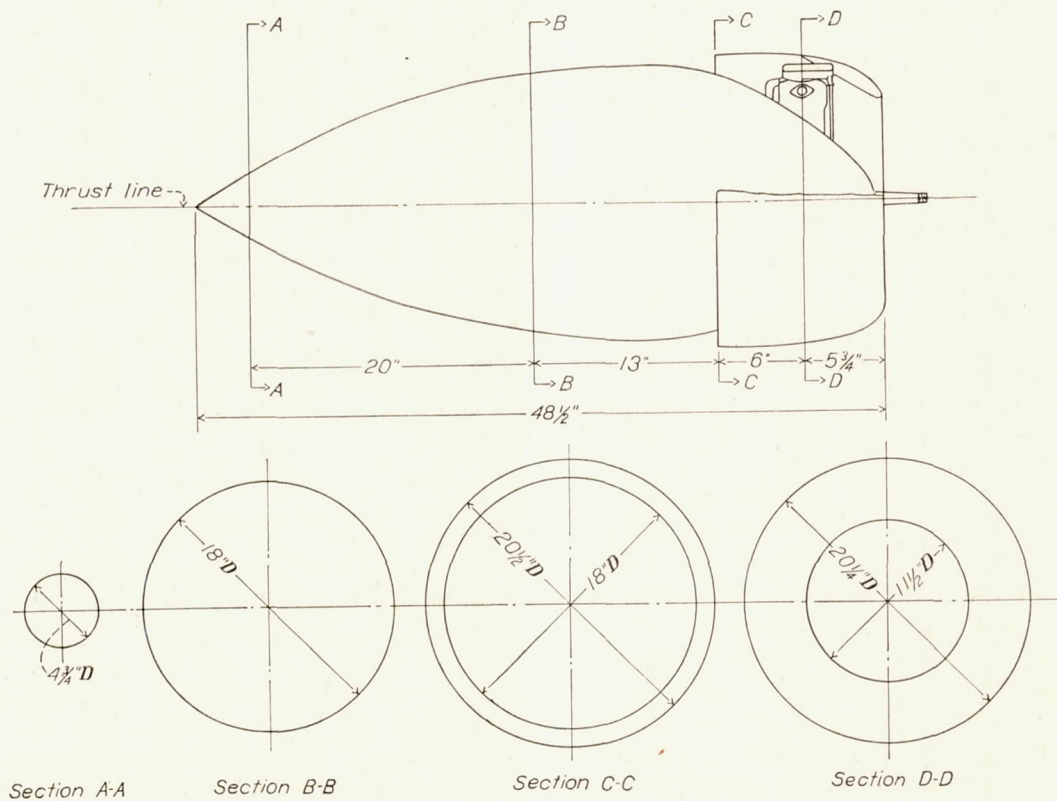

FIGURE 2.—N. A. C. A. cowled nacelle and engine assembly

wing. The latter three positions were selected mainly because they have been commonly used on airplanes constructed in the past and also because they are likely to continue in fairly general use for structural reasons

ing were tested both with and without propeller operating.

Whether or not fairings shall be used is always a moot question in airplane design, and accordingly the

effects of fairing the nacelle into the wing were investigated. In the course of the investigation certain other perhaps incidental items appeared. When the nacelle was originally installed ahead of the wing, it was supported by angle brackets which protruded from the sides of the nacelle and were covered over with fairings. These brackets were later removed and repeat tests were made to determine the effect of such appendages. When the nacelle is very near the wing and far back the cowling hood intersects the wing. The question of whether the resulting hollow should be faired arose, and the results of the tests are given. Whenever possible, comparisons of the results with those of the first series have been made.

The test program having assumed large proportions it was necessary to limit the number of tests, and in consequence the results are perhaps open to criticism. Although the test results do not represent the ultimate that can be obtained with simple cowlings, they do show the interference effects to a good approximation and, taken with the results for the N. A. C. A. cowled nacelle, present a fair picture of the relative merits

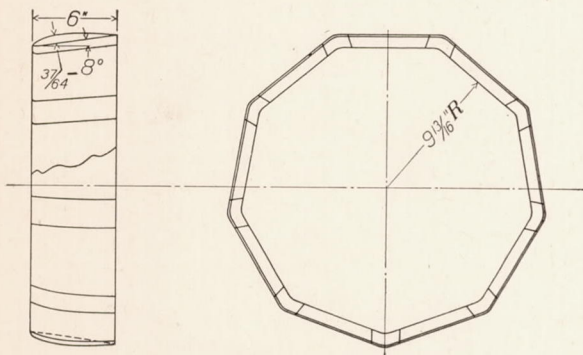

FIGURE 3.—Variable-angle ring

of tractor-propeller radial-engine nacelle and wing combinations.

APPARATUS AND METHODS

The propeller-research tunnel, in which the tests were made, is described in reference 2. The standard apparatus and test methods were used with certain exceptions mentioned later.

The wing is constructed of wood with a 5-foot chord and a 15-foot span. The airfoil section, the ordinates of which are given in Figure 1, reference 1, has a maximum thickness of 20 per cent of the chord. The central portion of the wing is provided with suitable metal ribs and plates for the connection of the struts required in attaching the nacelle to the wing.

The engine nacelle constructed of sheet duralumin was similar to nacelles required for a Wright J-5 radial engine, and was four-ninths (0.445) full scale. A detailed wooden model of this engine was installed in the proper position in the nacelle. This nacelle was constructed with the dimensions given in Figure 1, and represents a normal nacelle such as is employed when the engine is uncowled. All the tests of this

report were made with this nacelle (called small nacelle) and model engine. A larger nacelle fitted with a hood, the nacelle and hood constituting an N. A. C. A. cowled nacelle, was used in the tests of reference 1 and the hood was used in some of the tests of this report. The principal dimensions of this nacelle and the hood are given in Figure 2, which is reproduced from reference 1 for comparison.

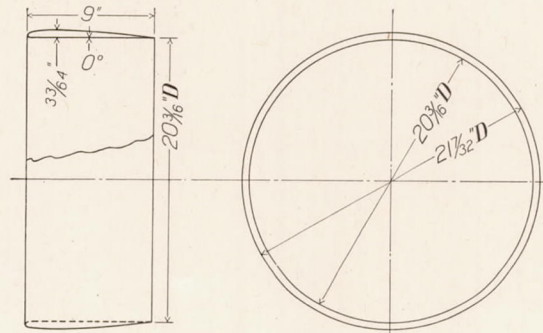

FIGURE 4.—Ring No. 1

The four cowlings fitted to the engine and small nacelle were of three distinct types: A narrow multi-sided ring, the angles of the sides of which could be adjusted; two wide thin rings with their chord lines 0° and -6.3° to the axis; and the hood previously used with the N. A. C. A. cowled nacelle. These are designated variable-angle ring, ring 1, ring 3, and N. A. C. A. hood, respectively, for purposes of reference. The principal dimensions are given in Figures 2, 3, 4, and 5. In preliminary tests on the nacelle alone, to be discussed in a later report, another ring (ring 2) having an angle

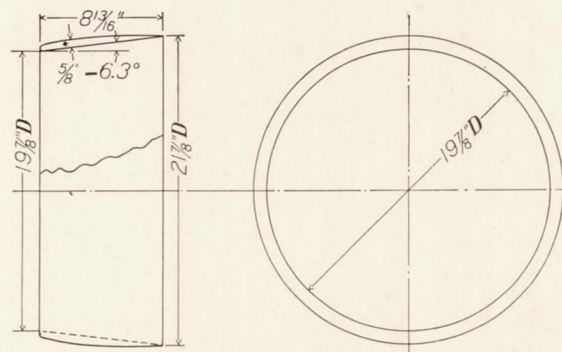

FIGURE 5.—Ring No. 3

of -3° was tested but showed no promise; consequently no further tests of it were made.

The wing-nacelle-propeller combination with the various cowlings was tested with the nacelle and wing in the four relative positions marked in Figure 6. In the figure the crosses indicate the positions of the center line of the propeller hub. The nacelle positions are designated by the system of letters shown.

The design of the variable-angle ring was based on the tests of reference 5 and the angle setting was determined in the preliminary tests. The -8° setting was found to give the lowest nacelle drag and was therefore used in the present tests with the wing.

on the tare drag. A Prony brake was used for calibrating the motor, and curves were obtained giving armature current against torque for several values of the field current. During the tests the field current was held at one of these calibrated values. Revolution speed was indicated by a condenser-type electric tachometer which occupied a small space in the nacelle and was connected by wires to an indicating instrument on the floor below.

The wing and nacelle combinations were mounted on the balance by means of standard supports, which have been described in reference 4. With these supports the airfoil pivots about a line near the lower surface 25 per cent of the chord back from the leading edge, and the angle of attack is adjusted by a crank operating a post connected with a sting on the airfoil. The airfoil and nacelle mounted in one test position are shown in Figure 7. Figures 8, 9, 10, and 11 are photographs of the other wing-nacelle set-ups, arranged in the order of the nacelle locations and cowlings. In all cases, the thrust line of the propeller was fixed parallel to the wing chord.

For use in subsequent analyses, a series of tests at various air speeds was made with the wing alone at angles of attack of -5° , 0° , 5° , 10° , and 12° . Similar tests were made with the small nacelle alone. In each case separate tare-drag tests were also made. The lift and drag forces were measured simultaneously by balances on the floor below. The Reynolds Number varied from about 2,300,000 at the lowest air speed (54 m. p. h.) to 4,300,000 at the highest speed (99 m. p. h.).

The first test with each combination was a run at several air speeds, with the propeller removed. The lift, drag, and air speed were measured. A second test was then made with the propeller in place, and with the tunnel operating at several air speeds. In this test the lift, drag (or thrust), torque, propeller revolutions, and air speed were measured. Separate tests were made at angles of attack of -5° , 0° , 5° , 10° , and 12° . At the 12° angle only a few points were determined near zero thrust.

With the nacelles in positions B-1-A and A-1-B the tests were made both with the nacelle supported by struts only and with the struts surrounded by a fairing joining the wing and nacelle. With the nacelle in position B the supports as originally installed protruded from the sides of the nacelle. These brackets although faired were considered to be of doubtful utility and accordingly repeat tests were made with them removed. The fairings and struts are clearly shown in the photographs.

With the nacelle in positions A-1-A and A-1-B the engine cowling intersects the wing in a manner that may account for some unfavorable interference. In

the tests of reference 1 the cowling was faired into the wing as shown in the photographs at the right of Figure 12. Airfoil tests were later made with the hood fairing removed as indicated at the left of Figure 12, and the comparative results are given here.

RESULTS

The measured lift and drag were reduced to the usual coefficients

$$C_L = \frac{\text{Lift}}{q S} \quad C_D = \frac{\text{Drag}}{q S} \quad C_m = \frac{\text{Moment}}{q S c}$$

where

q , the dynamic pressure ($\frac{1}{2} \rho V^2$).

ρ , mass density of the air.

V , velocity.

S , the area of the wing.

c , the chord of the wing.

(All moments are taken about the quarter-chord point of the wing.)

These coefficients were first plotted against the dynamic pressure q and then cross plotted as C_L , C_D , and C_m against α (angle of attack) at values of the dynamic pressure corresponding to 50, 75, and 100 m. p. h.

Since the principal interest is in the comparative results with various cowlings in the different positions, the lift and drag coefficients have been plotted as polar diagrams arranged in a manner to facilitate such comparisons. The N. A. C. A. cowled nacelle is nothing more than an improved engine cowling and should obviously be examined with the other types. Accordingly, in the photographs, figures, and tables information from reference 1 has been included to complete the series.

In Figures 13 to 16 polar diagrams are given of the lift and drag coefficients obtained with the various cowlings in the four nacelle positions. Figures 17 and 18 show the results for positions A-1-B and B-1-A with and without fairing. Figure 19 shows the effect of side brackets on the nacelle in position B and Figure 20 the effect of hood fairing on the N. A. C. A. cowled nacelle in positions A-1-A and A-1-B. Figure 21 compares the results with rings 1 and 3 with those for the variable-angle ring. Figures 22 and 23 show the comparative results for two cowlings in all four nacelle positions, Figure 22 the small nacelle without cowling, and Figure 23 the N. A. C. A. cowled nacelle. All these diagrams are plotted from the data obtained at an air speed of 100 m. p. h. The results are also given in Tables I and II, together with those for two other air speeds, 50 and 75 m. p. h.

The results with the propeller operating are reduced to the usual coefficients

$$C_T = \frac{T - \Delta D}{\rho n^2 D^4} \quad C_P = \frac{P}{\rho n^3 D^5}$$

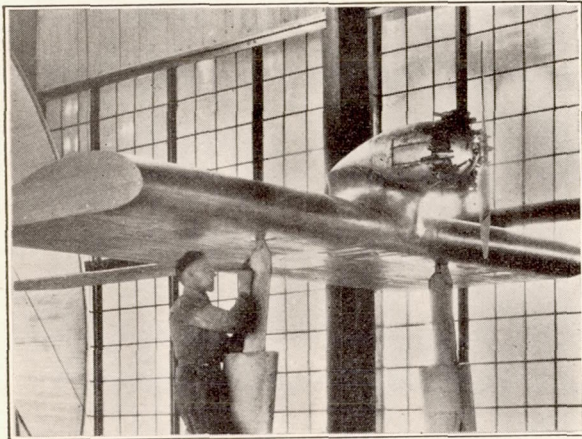

Small nacelle, exposed cylinders, faired into wing.

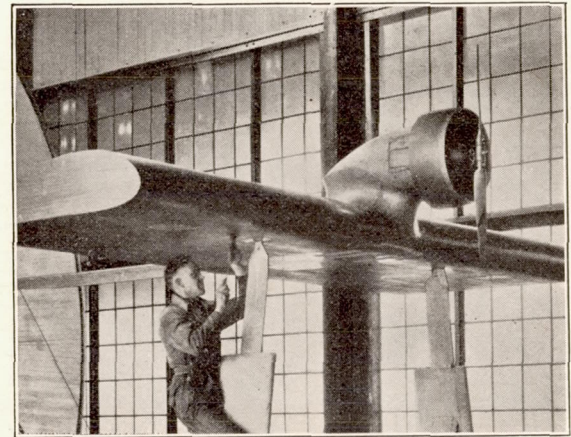

Small nacelle, ring No. 3, faired into wing.

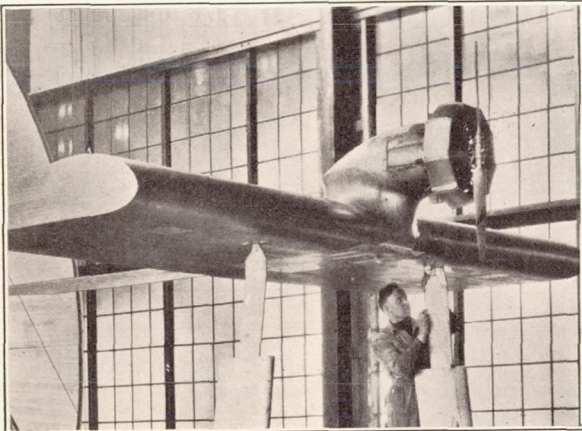

Small nacelle, variable-angle ring set -8° , faired into wing.

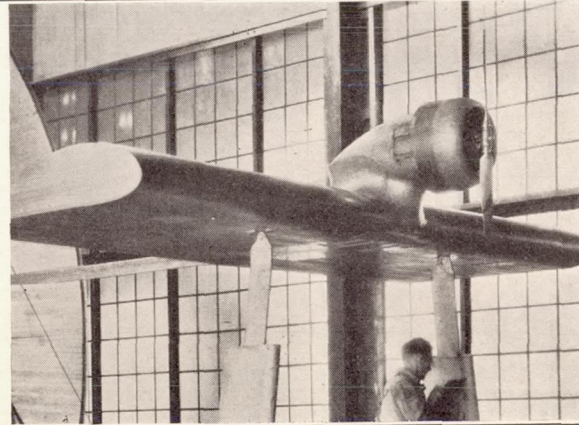

Small nacelle, N. A. C. A. hood, faired into wing.

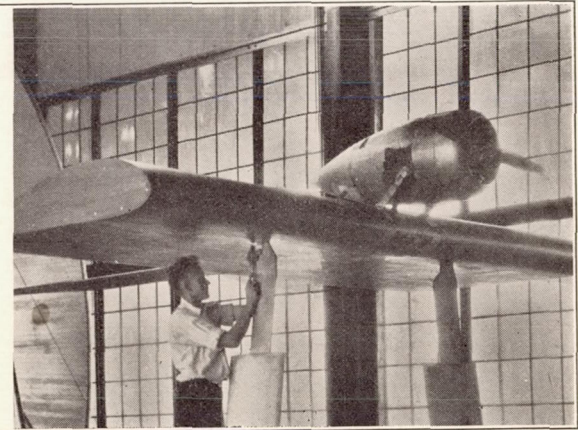

N. A. C. A. cowled nacelle, not faired into wing.

FIGURE 8.—Nacelles in position B-1-A

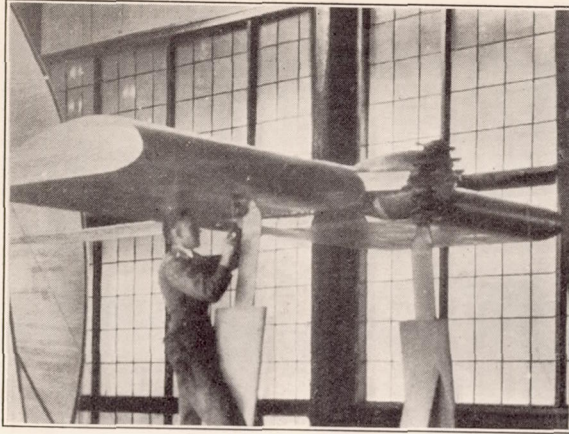

Small nacelle, exposed cylinders, with side bracket fairing.

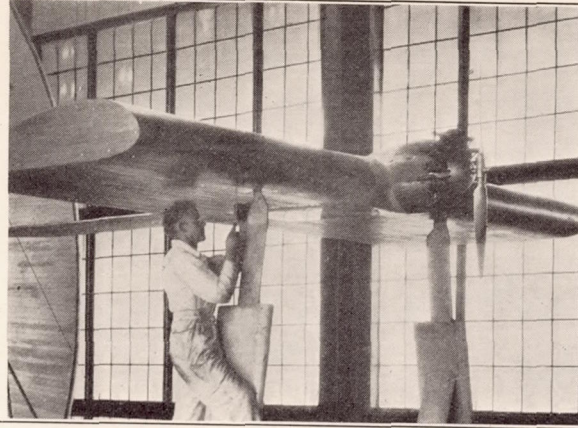

Small nacelle, exposed cylinders, without side brackets.

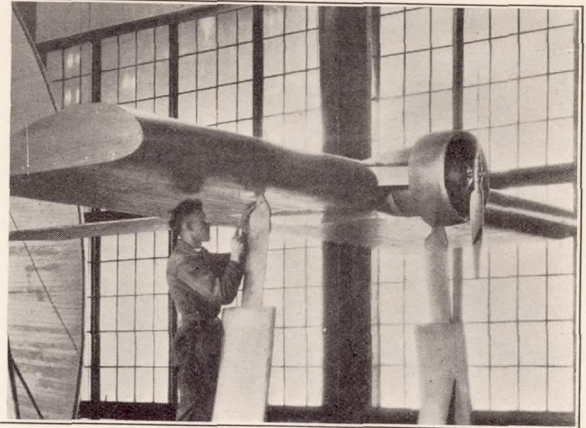

Small nacelle, ring No. 3, with side bracket fairing.

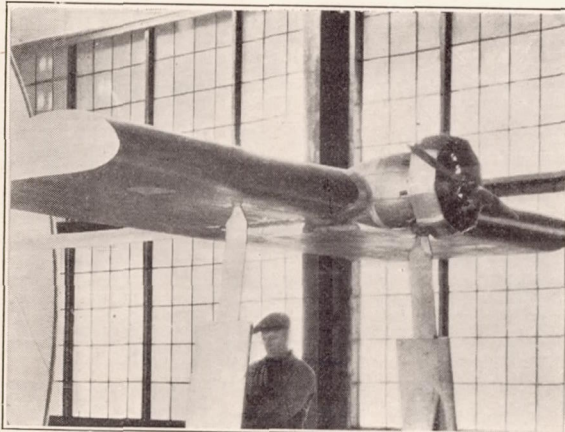

Small nacelle, variable-angle ring set -8° .

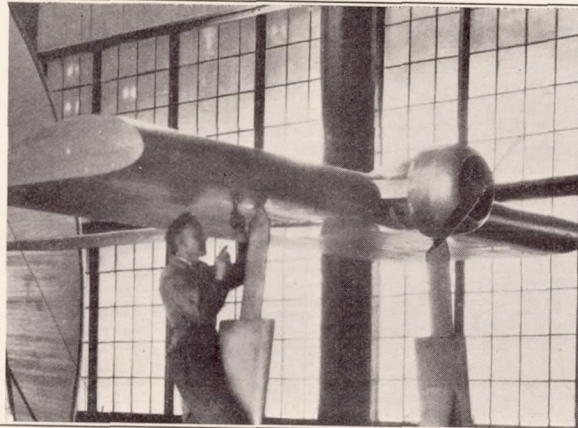

Small nacelle, N. A. C. A. hood.

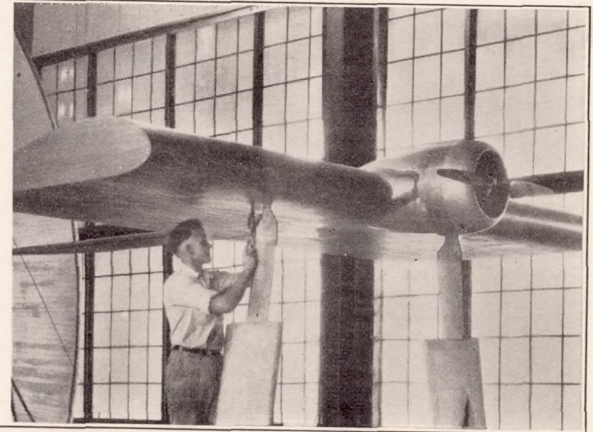

N. A. C. A. cowlled nacelle.

FIGURE 9.—Nacelles in position B

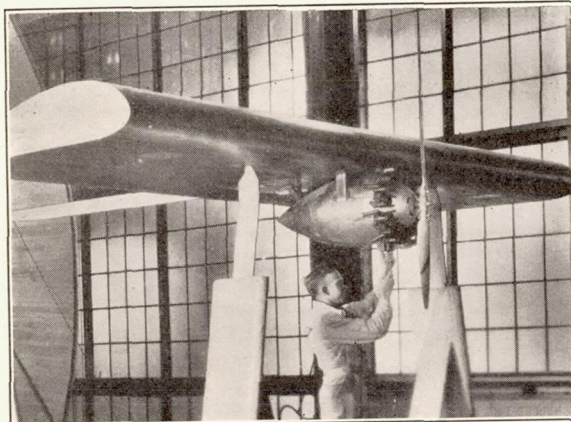

Small nacelle, exposed cylinders, not faired into wing.

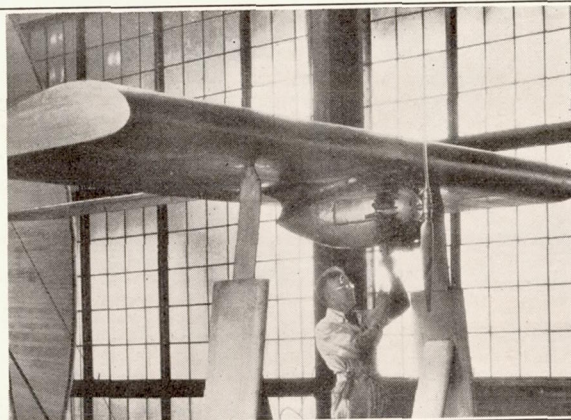

Small nacelle, exposed cylinders, faired into wing.

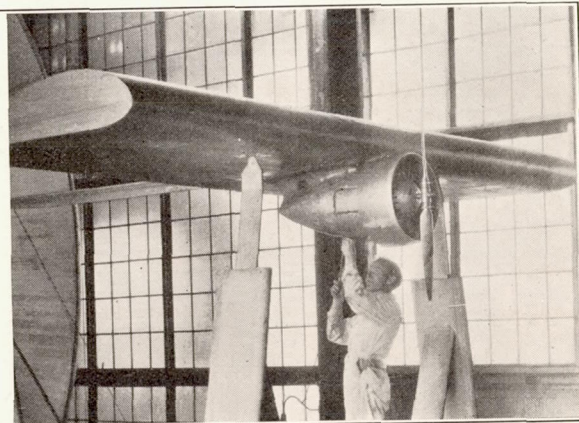

Small nacelle, ring No. 3, faired into wing.

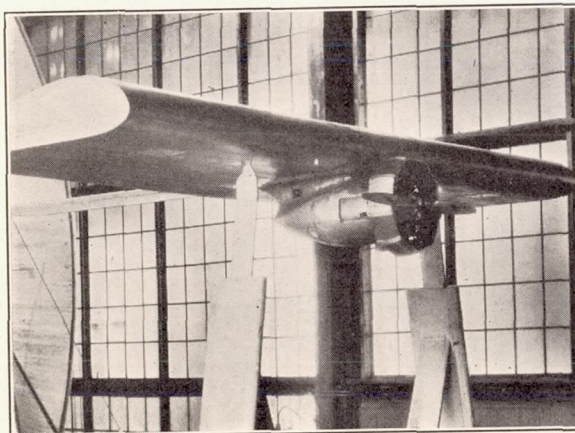

Small nacelle, variable-angle ring set -8° , faired into wing.

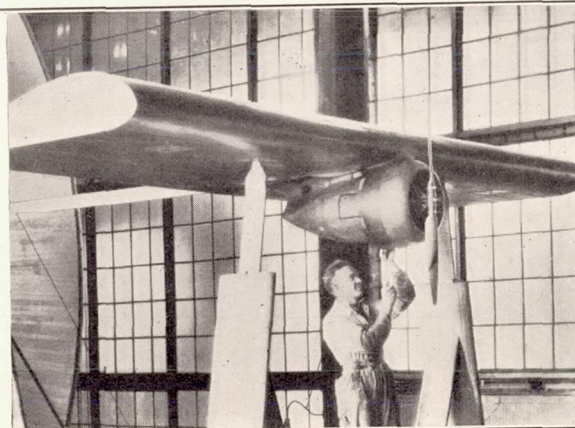

Small nacelle, N. A. C. A. hood, faired into wing.

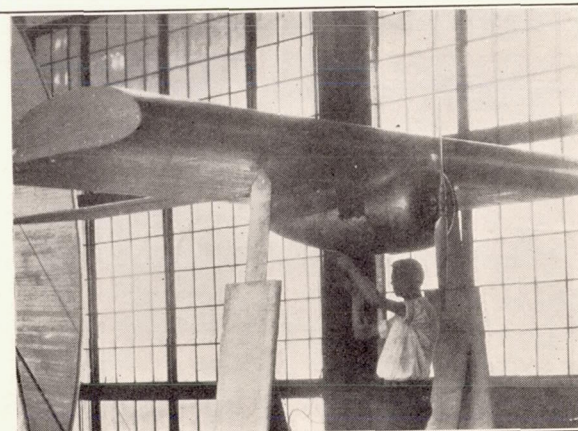

N. A. C. A. cowled nacelle, faired into wing.

FIGURE 10.—Nacelles in position A-1-B

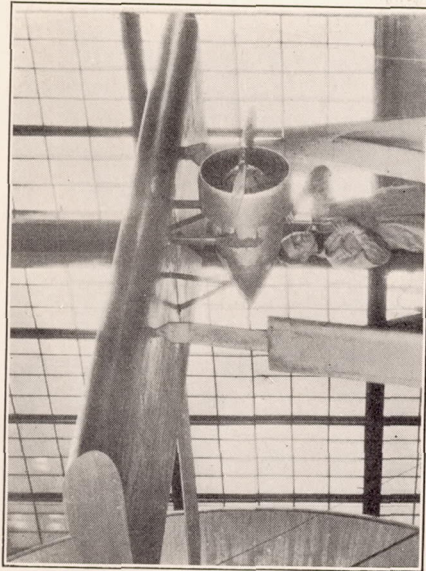

Small nacelle, ring No. 3.

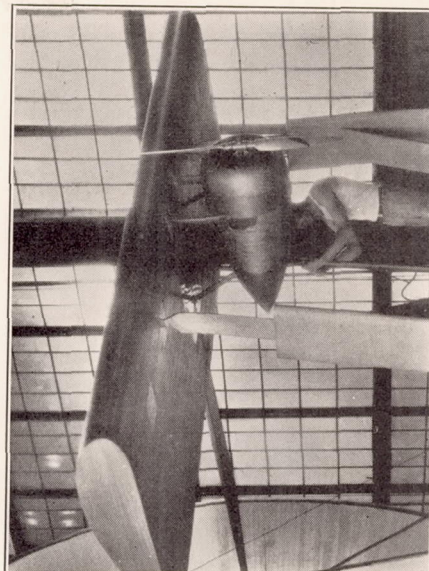

N. A. C. A. cowled nacelle.

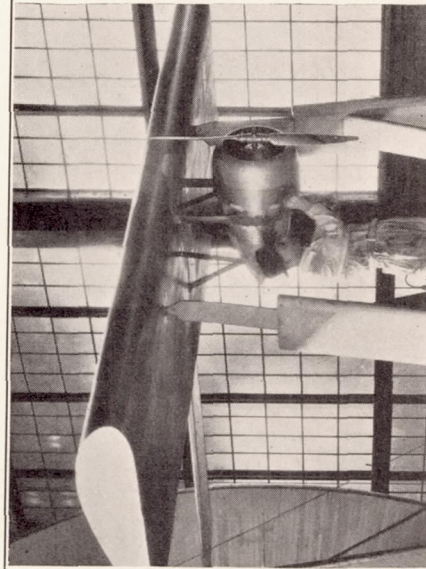

Small nacelle, N. A. C. A. hood.

FIGURE 11.—Nacelles in position A-2-B

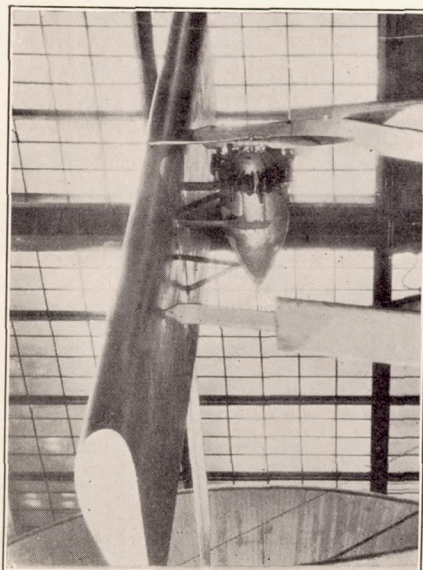

Small nacelle, exposed cylinders.

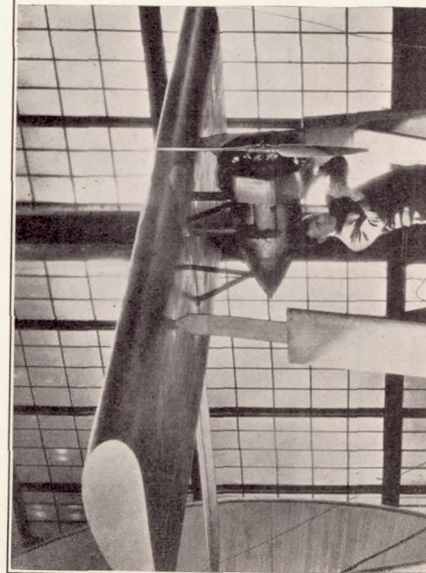

Small nacelle, variable-angle ring set -8° .

where

T , thrust of propeller operating in front of a body (tension in crankshaft).

ΔD , change in drag of body due to action of propeller.

$T - \Delta D$, effective thrust (discussed in reference 3).

n , revolutions per unit time.

D , propeller diameter.

P , motor power.

VIII, Moment Coefficient with Propeller Operating (C_{mP}). The plots of these results follow the normal trends of propeller characteristic curves and, since only individual values are used in later comparisons, no curves are reproduced here. The reader is referred to reference 1 for a typical set of such curves.

ACCURACY

All readings were taken on scales and instruments that were calibrated frequently during the tests. The

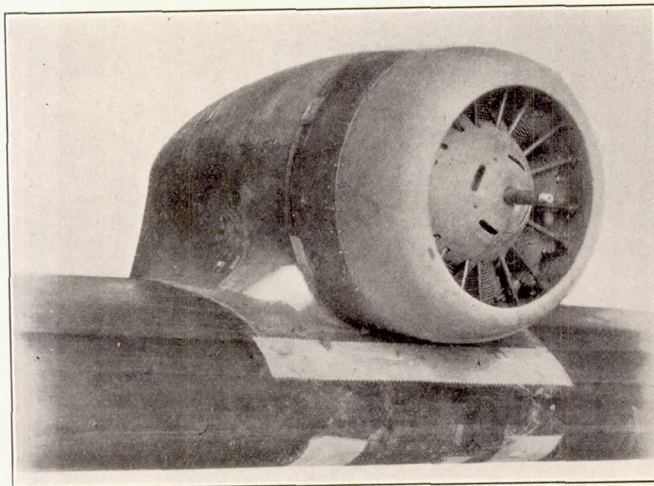

N. A. C. A. cowled nacelle in position A-1-A, without hood fairing.

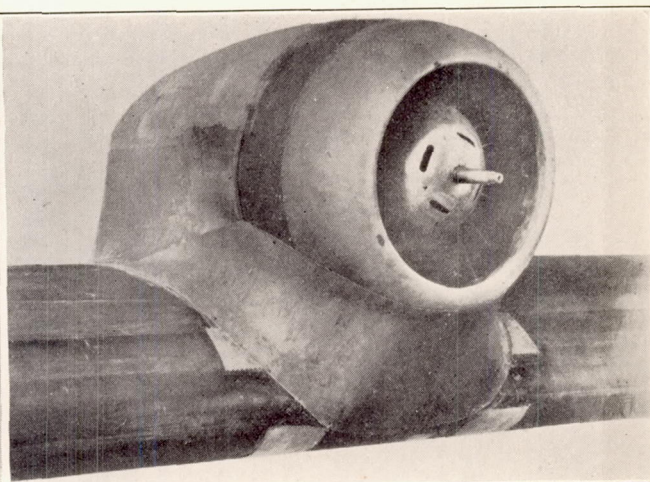

N. A. C. A. cowled nacelle in position A-1-A, with hood fairing.

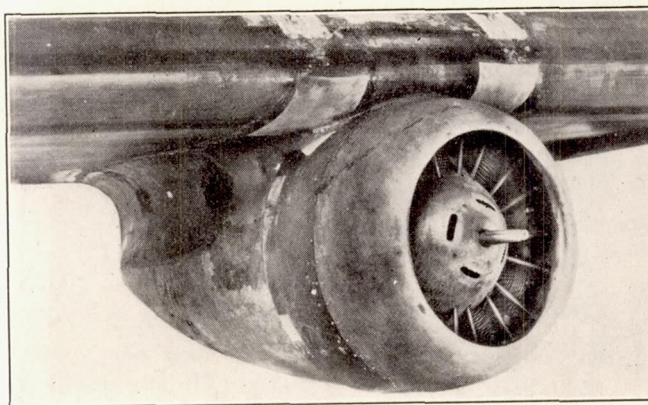

N. A. C. A. cowled nacelle in position A-1-B without hood fairing.

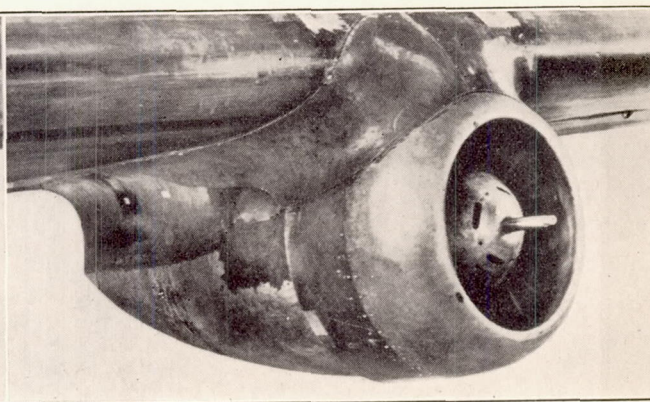

N. A. C. A. cowled nacelle in position A-1-B, with hood fairing.

FIGURE 12.—N. A. C. A. cowled nacelle with and without hood fairing

and

$$\begin{aligned} \eta &= \text{propulsive efficiency} \\ &= \frac{\text{effective thrust} \times \text{velocity of advance}}{\text{motor power}} \\ &= \frac{(T - \Delta D)V}{P} = \frac{C_T V}{C_P nD} \end{aligned}$$

and C_L and C_m are computed as before but are now called C_{LP} and C_{mP} .

The coefficients for all nacelle positions at various values of $\frac{V}{nD}$ and the different angles of attack are given in Tables IV to VIII, inclusive: Table IV, Thrust Coefficient (C_T); Table V, Power Coefficient (C_P); Table VI, Propulsive Efficiency (η); Table VII, Lift Coefficient with Propeller Operating (C_{LP}); Table

angles of attack of the airfoil were set within 5 minutes of the desired angles with an inclinometer. The motor calibration showed a scattering of the points representing a maximum error of 1 per cent. The tachometer readings were accurate within 10 revolutions per minute. The lift and drag were measured to the nearest pound.

With certain nacelle positions at high angles of attack the forces fluctuated rapidly and the above accuracy could not be obtained. This fluctuation was particularly noticeable near the burble point of the airfoil. The major portion of the faired results are believed to be correct within ± 2 per cent, when the scattering of the test points and the accuracy of the instruments are considered.

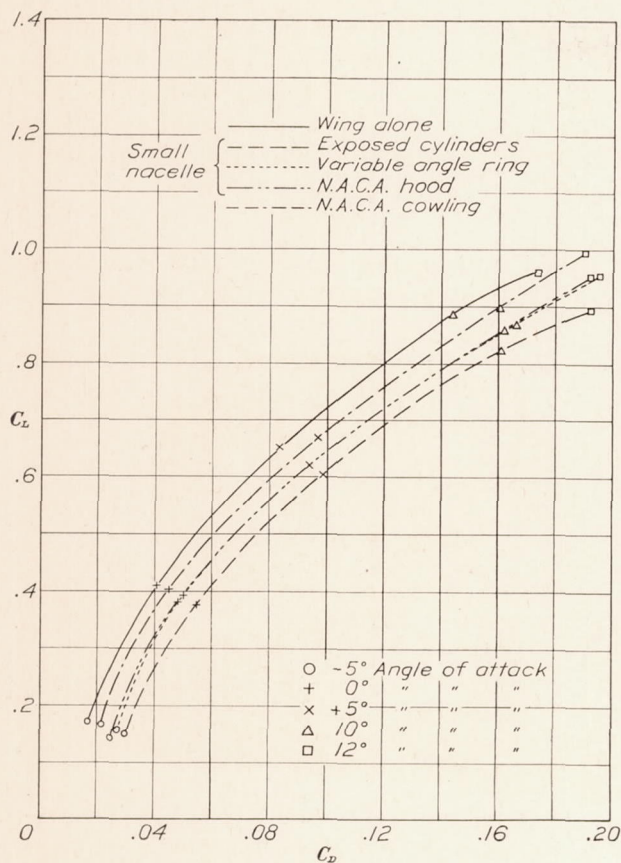

FIGURE 13.—Comparison of lift and drag characteristics for wing alone and nacelle combinations in position B-1-A faired into wing

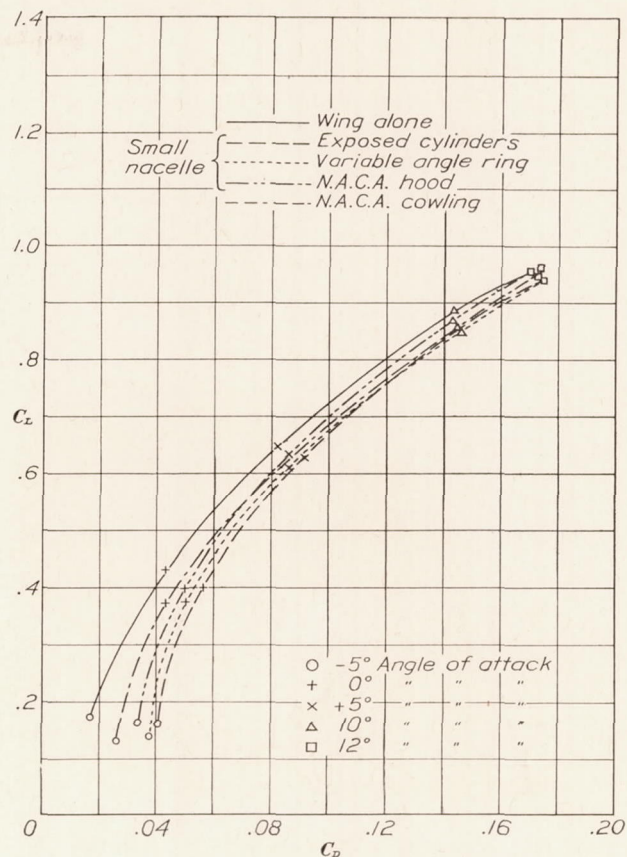

FIGURE 15.—Comparison of lift and drag characteristics for wing alone and nacelle combinations in position A-1-B, faired into wing

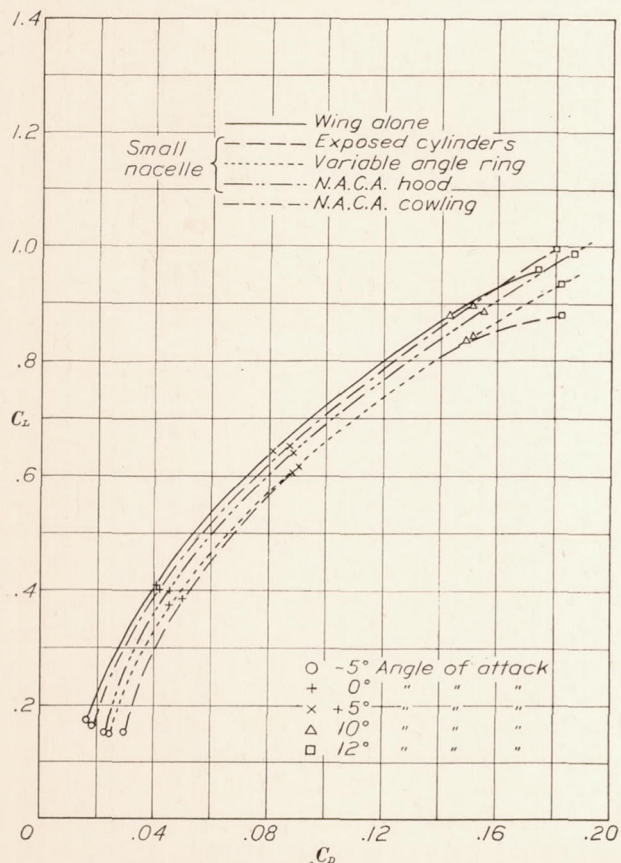

FIGURE 14.—Comparison of lift and drag characteristics for wing alone and nacelle combinations in position B, side brackets removed

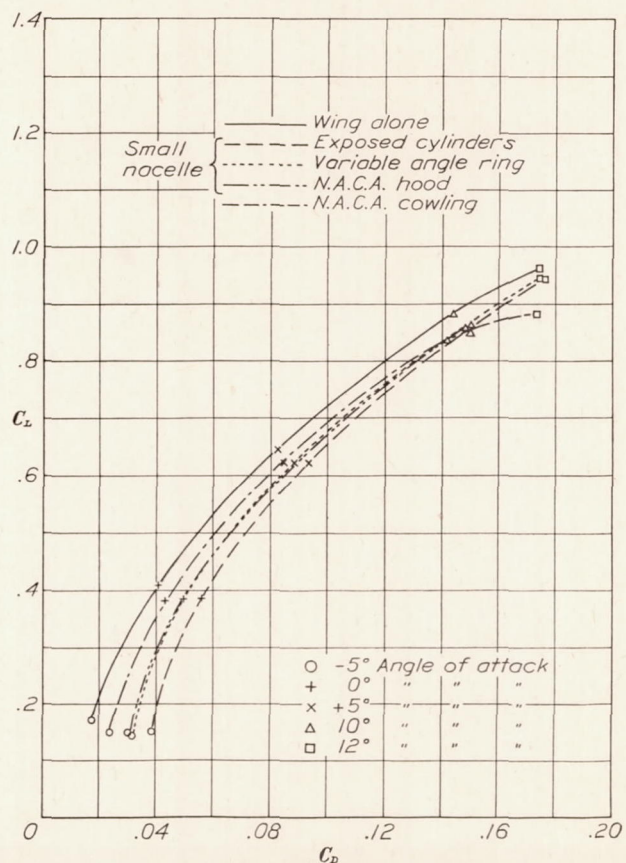

FIGURE 16.—Comparison of lift and drag characteristics for wing alone and nacelle combinations in position A-2-B

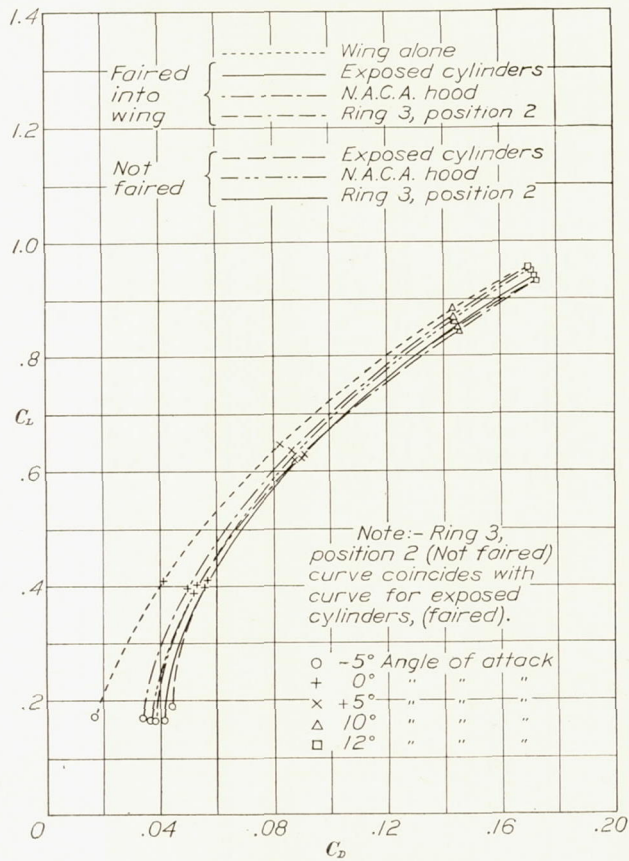

FIGURE 17.—Comparison of lift and drag characteristics for wing alone and nacelle combinations in position A-1-B showing effect of fairing into wing

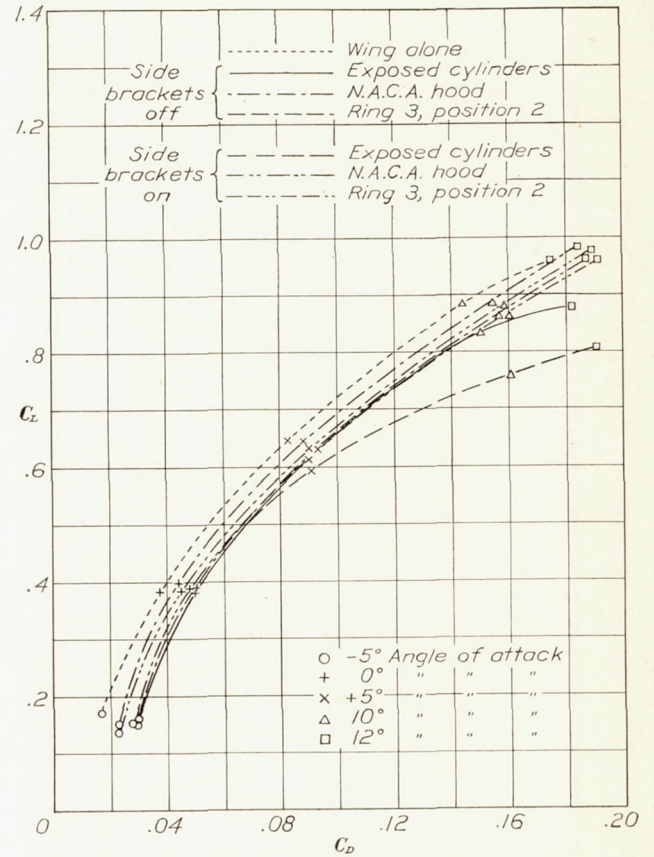

FIGURE 19.—Comparison of lift and drag characteristics for wing alone and nacelle combinations in position B showing effect of side brackets

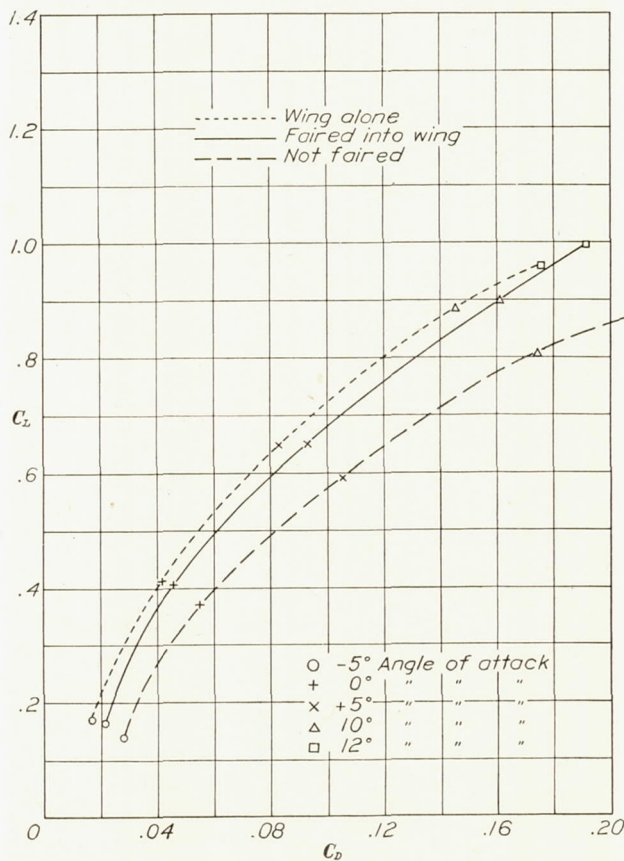

FIGURE 18.—Comparison of lift and drag characteristics of N. A. C. A. cowled nacelle in position B-1-A showing effect of fairing into wing

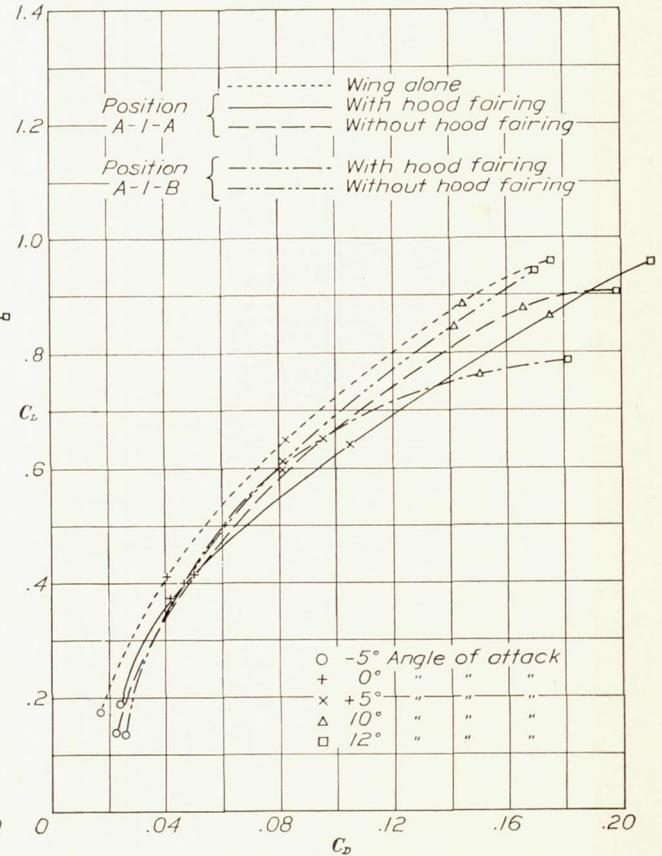

FIGURE 20.—Comparison of lift and drag characteristics for wing alone and N. A. C. A. cowled nacelle combination in positions A-1-A and A-1-B showing effect of hood fairing

DISCUSSION

A consideration of the general problem of a nacelle with a propeller operating in proximity to a wing indicates that several factors should be considered. The nacelle and wing have mutual interferences which appear as changes in the lift and drag. The propeller characteristics are influenced by the presence of the wing and nacelle and the slipstream in turn changes the forces on the wing and nacelle. A detailed discussion of these questions is given in reference 1, and it is concluded that a comparison of the relative merits of wing-nacelle-propeller combinations must include pro-

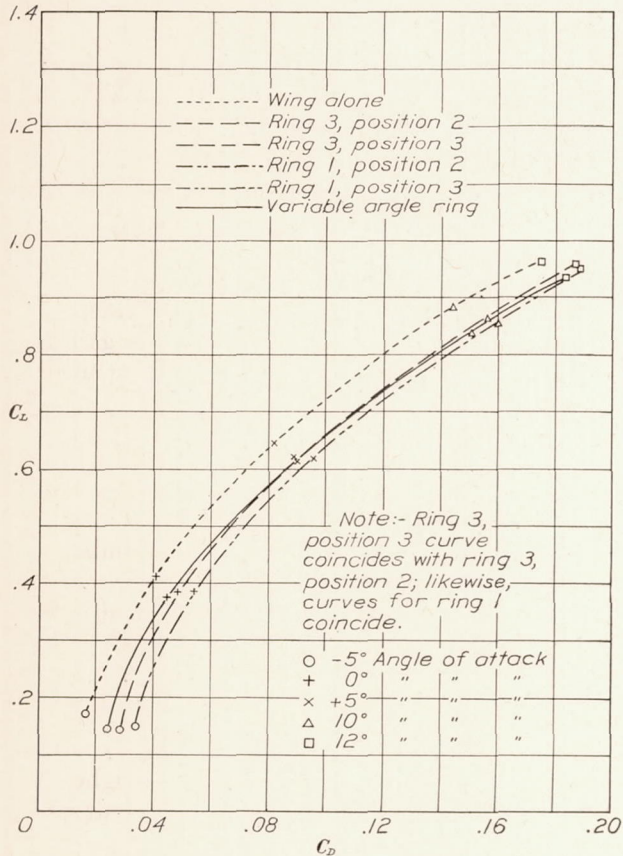

FIGURE 21.—Comparison of lift and drag characteristics for wing alone and nacelle combinations in position B showing effect of cowling ring type and position

pulsive efficiency, interference-drag effects, and lift effects. A net efficiency is derived therein which includes the above factors in a rational and simple manner. The same methods are employed here.

INTERFERENCE LIFT AND DRAG

Although the largest item in the net efficiency is the propulsive efficiency, the interference-drag effects have a large influence and a great deal may be learned from an examination of lift and drag data from the tests made without propeller.

Accordingly, these results are first discussed and later the propeller effects are included. Beside simplifying the discussion, a clearer picture of the phenomena is perhaps obtained. In Figures 13 to 23 each line represents a different combination of nacelle and

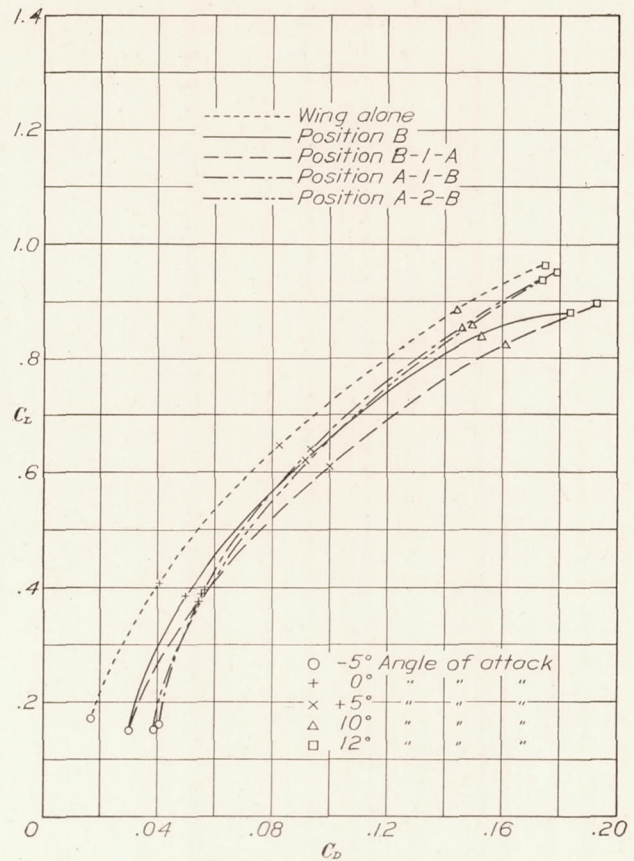

FIGURE 22.—Comparison of lift and drag characteristics of wing alone and exposed cylinder nacelle combination in four positions

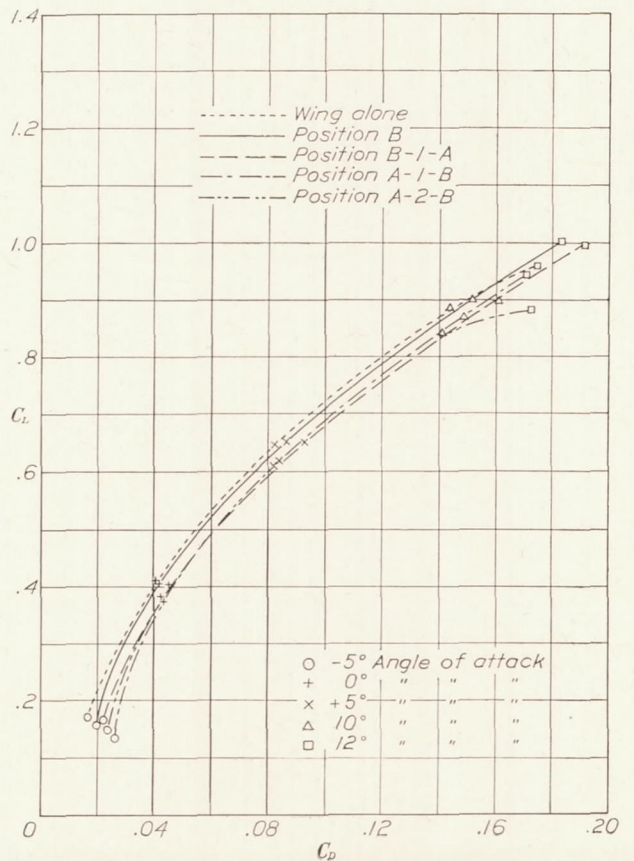

FIGURE 23.—Comparison of lift and drag characteristics of wing alone and N. A. C. A. cowled nacelle combination in four positions

cowling plotted as a polar diagram C_L against C_D with the polar of the wing alone also given. The abscissa intercept between the wing-alone polar and that for any wing-nacelle-cowling combination represents the drag added by the nacelle, i. e., the nacelle drag plus wing-nacelle interference drag. Similarly, the ordinate intercept represents the lift change due to the nacelle and cowling. These intercepts are of fundamental importance because the arrangement which develops the least increase of drag (that polar closest to the wing-alone polar) is the best considering only the lift and drag.

In Figure 13 which shows the results with nacelle and cowlings in position B-1-A, at a lift coefficient of 0.4 corresponding to 0° for the wing alone, the drag added by the small nacelle with exposed engine cylinders is about four times that added by the completely cowled nacelle; that added by the N. A. C. A. hood or variable-angle ring and the small nacelle is about two and one-half times that added by the completely cowled nacelle. These proportions hold approximately at other angles of attack. The loss of lift at a given angle of attack for the nacelle with exposed engine cylinders is also to be noted. The advantage of cowling is amply evident. Similar conclusions are drawn from Figure 14 showing the results for position B. In this position the nacelle is partly within the wing so that the drag added is not so large. Nevertheless, the nacelle with exposed cylinders adds about six times and variable-angle ring four times the drag of the completely cowled nacelle. The loss of lift is again evident. The results for positions A-1-B and A-2-B shown in Figures 15 and 16 are of the same character. The results for position A-1-B (fig. 15) are especially interesting. Here the cowling is not of so much advantage and this advantage disappears at the higher angles of attack. This result confirms early flight tests on cowled engine nacelles made soon after the development of the N. A. C. A. type of cowling. In position A-2-B where the nacelle is farther from the wing the cowling is more useful but still loses its value at high angles of attack. In no case is cowling a detriment and in the best nacelle position, position B, it is a decided advantage, eliminating the loss of lift which occurs when no cowling is used.

The results just discussed were obtained with the nacelle faired into the wing except in position A-2-B. Figure 17 indicates the effect of the fairing giving the results with and without fairing for position A-1-B. Fairing between the nacelle and wing eliminates about 25 per cent of the drag added by the cowled nacelles. On the nacelle without cowling the fairing has no effect. The air surrounding the nacelle is apparently so stirred up by the engine cylinders that fairing can not smooth the flow. When the nacelle is above the wing where the velocity is higher the effects are even

more pronounced, as indicated in Figure 18. This result was given in the tabular data of reference 1 but is so striking that it is reproduced as a curve here. The drag due to the nacelle is reduced 75 per cent by fairing and this with the completely cowled nacelle in both instances. The cases cited point to the necessity of careful fairing when the nacelle is near the wing. The gains are more pronounced above the wing than below and with cowling than without.

Another interesting side light on fairings is given by the results of the tests with and without side brackets on the nacelle in position B. These are given in Figure 19. It appears that about half the drag due to the nacelle with hood is caused by these brackets. With ring 3 and the uncowed nacelle very little gain is evident from removing the brackets. The most surprising result is the improvement of lift. Where with side brackets the lift at 10° was only 85 per cent of the lift of the wing alone, with brackets removed it is 95 per cent, nearly equal to the cowled nacelle and wing combinations. This nacelle position shows the best over-all results, as will appear later, but the engine must be cowled and all protuberances eliminated for best results.

A second variation of fairings is indicated in Figure 12, and the results are given in Figure 20. It was considered that the intersection between the hood over the cylinders and the wing might produce unfavorable interference, and a fairing was placed over the front as shown. The results indicate practically no effect at 0° angle of attack and below, but at higher angles the fairing on the hood is a serious detriment resulting in large increases of drag as well as decreases of lift, particularly in position A-1-A. This nacelle location is poor on other grounds also (reference 1) and should be avoided. Unfortunately, propeller tests were not made with the fairing removed, so that the net results for the completely cowled nacelle in these positions are slightly poorer than they would have been with the fairing removed.

The discussion thus far has been confined to general interference effects, and no attempt has been made to evaluate definitely. It is evident by now, however, that the N. A. C. A. cowled nacelle is the best. The N. A. C. A. hood applied to the small nacelle is better than the variable-angle ring. Although rings 1 and 3 do not give as good results as the other cowlings tested, they do represent types strikingly similar to cowlings that have been observed on a number of airplanes. Although they are not recommended, the results of some tests are given in Figure 21, where they are compared to the variable-angle ring. Ring 3 is slightly poorer than the variable-angle ring at low angles, and ring 1 is poorer throughout. This result is perhaps accounted for by the difference in angle, -6.3° against -8° . Rings 1 and 3 are circular, but the variable-angle ring has nine sides and there is reason

to suppose it would be improved if made circular also, which could be done once the angle were fixed. No effect of changing the fore-and-aft position of the rings is noted. The -8° angle for the variable-angle ring gives the lowest drag. Recent tests, however, on another part of this project have indicated that the net efficiency is improved when the angle is made less. The results of the tests of these rings are consequently only useful as indications of possible results. The alterations just indicated may improve the results, but it is not likely that any ring on a small nacelle can be made equal to a ring or hood on a large nacelle. Practical considerations often dictate the simpler arrangement, however.

As a final consideration of the interference part of the problem, Figures 22 and 23 present the results from tests of the exposed cylinder nacelle and the N. A. C. A. cowled nacelles in the various positions. There is no reason why there should be any agreement of results; but apparently the cowled-nacelle polars follow an almost parallel course whereas the uncowed results indicate one position best at one angle of attack and another at another. Position B is decidedly better throughout with a completely cowled nacelle. It is particularly poor at high angles with an uncowed nacelle. Fairing the completely cowled nacelle into the wing, which showed such an improvement in position B-1-B (fig. 18), did not do this with the uncowed nacelle except at low angles. The other results are entirely in favor of the cowled nacelle, although this advantage disappears to a large extent at high angles of attack. This is, of course, to be expected from the nature of the drag, the wing drag increasing rapidly with angle of attack whereas the drag added by the nacelle is substantially constant.

NET EFFICIENCY

The foregoing discussion represents the conclusions that are arrived at without considering the propeller. They are similar to what would result from any model tests where only the nacelle and wing were present. The principal advantage of the present tests, however, is the study of the effects of the operating propeller. The propeller supplies the thrust necessary to pull the airplane through the air and a proper determination of the thrust available under any given conditions for the different nacelle-propeller-wing combinations is the key to the relative merits of the different arrangements.

The variation of the lift and drag without propeller has just been examined in detail. When the propeller is operating, further changes occur and, in addition, the propeller is affected by the presence of the nacelle and wing.

These effects have been discussed at length in reference 1 and two factors are developed which are summed up to give the net efficiency, a measure of the real merit

of any wing-nacelle-propeller combination.

These factors are:

(1) The propulsive efficiency representing the ratio of the effective thrust power to the motor power. Effective thrust is defined as the propeller thrust minus the increase of drag due to the slipstream, so that the effects of the propeller on the body and the body on the propeller are accounted for.

(2) The nacelle drag efficiency factor representing the fraction of the motor power which is used in overcoming the drag and interference of the nacelle.

The net efficiency, (1) minus (2), represents the fraction of the total motor power that is available for overcoming the drag of other parts of the airplane exclusive of the nacelle. A high value of net efficiency indicates a high propulsive efficiency or low nacelle drag efficiency factor, or both. In any case the higher the value the better the arrangement.

The details of the derivation of these factors are given in reference 1 and the resulting formulas only are repeated here.

$$\text{Propulsive efficiency} = \eta = \frac{(T - \Delta D) V}{P} = \frac{C_T}{C_P} \cdot \frac{V}{nD}$$

$$\text{Nacelle drag efficiency factor} = \frac{C_{DC} - C_{DW}}{C_P} \cdot \frac{S}{2D^2} \left(\frac{V}{nD} \right)^3$$

$$\text{Net efficiency} = \frac{C_T}{C_P} \frac{V}{nD} - \frac{C_{DC} - C_{DW}}{C_P} \cdot \frac{S}{2D^2} \left(\frac{V}{nD} \right)^3$$

where C_{DW} , drag coefficient of the wing at a given angle of attack.

C_{DC} , drag coefficient of the wing-nacelle combination at the same lift coefficient as the wing alone, and the other symbols as previously defined.

These formulas may be applied to any operating condition, and if the conditions are fixed for all nacelle-propeller-wing combinations, a direct comparison may be made. Following the method of reference 1, the factors have been computed for an angle of attack of the wing alone of 0° ($C_L = 0.409$) and a propeller $\frac{V}{nD} = 0.65$, corresponding to an assumed high-speed operating condition, and also for an angle of attack of the wing alone of 5° ($C_L = 0.652$) and $\frac{V}{nD} = 0.42$, corresponding to climb. The high-speed $\frac{V}{nD}$ is the average value at which the propeller operated at peak efficiency in the tests. The climb $\frac{V}{nD}$ is the corresponding average value obtained by assuming a climbing speed equal to 60 per cent of the high speed and the motor power reduced in proportion to the engine speed, i. e., the engine developing constant torque, which is substan-

tially true for airplane engines. The lift effect of the propeller is accounted for by adjusting the angle of attack to give the same lift as the wing alone as noted in the definition of C_{DC} so that the comparisons are essentially for the same speed, although the actual speed is undetermined.

The factors thus derived for the nacelles and cowlings in the different positions are given in Tables IX and X. The corresponding data from reference 1 are also given for comparison.

Without going into great detail it is at once apparent that the propeller has considerable influence on the final result. The effect of the cowling on propulsive efficiency is first noted. In the high-speed condition (Table IX) the N. A. C. A. cowled nacelle gave the least propulsive efficiency and ring 1 on the small nacelle the highest. The propulsive efficiency with the small nacelle uncowed is also considerably higher than with the N. A. C. A. cowled nacelle. These results are in agreement with those of numerous other tests. Apparently, bodies of high drag behind the propeller give higher propulsive efficiencies than low-drag bodies. In other words, the higher propeller efficiency partly compensates for the drag of a poor body.

These fortunate changes of the propulsive efficiency are, however, insufficient to produce higher net efficiencies. In the case of the small nacelle uncowed and with ring 1 the drag is very high so that the net result is poorer than for the N. A. C. A. cowled nacelle in all cases. It is of interest to note that the order of merit for the different positions is the same as was derived from the consideration of drag alone. This circumstance is considered merely fortuitous and it may be said that the correct determination of the nacelle location must include the propeller effects.

In the climb condition (Table X) the differences are, as expected, less marked. The propeller evidently contributes a great deal, however, owing to the considerable vertical component of thrust and increase in velocity over the wing. The nacelle drag efficiency factors are mainly negative, indicating a favorable influence of nacelle and propellers. The same order of merit obtains, however, as for high speed and the use of cowling is of some advantage.

CONCLUSIONS

The following conclusions are based on a general survey of the results of the tests. Other conclusions might

be drawn, but would probably have to be modified for other arrangements than those tested here.

1. The drag and interference of nacelles are reduced by cowling the nacelle. Cowled nacelles located near the wing, however, should be carefully faired into the wing rather than supported by struts only.
2. Side brackets on nacelles ahead of the wing should be avoided.
3. Fairing the cowling hood into the wing is to be avoided.
4. The propulsive efficiency of nacelle-propeller-wing combinations is reduced by adding cowlings to the nacelle.
5. The net efficiency is greatest for a completely cowled nacelle.
6. The best location of a tractor nacelle is about 25 per cent of the chord ahead of the leading edge of the wing. To avoid a reduction in lift the nacelle should be cowled.
7. The location of the nacelle and the type of cowling are of great importance at high speed but are of little importance at climbing speeds.

LANGLEY MEMORIAL AERONAUTICAL LABORATORY,
NATIONAL ADVISORY COMMITTEE FOR AERONAUTICS,
LANGLEY FIELD, VA., *May 12, 1932.*

REFERENCES

1. Wood, Donald H.: Tests of Nacelle-Propeller Combinations in Various Positions with Reference to Wings. Part I. Thick Wing—N. A. C. A. Cowled Nacelle—Tractor Propeller. T. R. No. 415, N. A. C. A., 1932.
2. Weick, Fred E., and Wood, Donald H.: The Twenty-Foot Propeller Research Tunnel of the National Advisory Committee for Aeronautics. T. R. No. 300, N. A. C. A., 1928.
3. Weick, Fred E.: Working Charts for the Selection of Aluminum Alloy Propellers of a Standard Form to Operate with Various Aircraft Engines and Bodies. T. R. No. 350, N. A. C. A., 1930.
4. Wood, Donald H.: Tests of Large Airfoils in the Propeller Research Tunnel, Including Two with Corrugated Surfaces. T. R. No. 336, N. A. C. A., 1929.
5. Townsend, H. C. H.: Reduction of Drag of Radial Engines by the Attachment of Rings of Aerofoil Section, Including Interference Experiments of an Allied Nature, with Some Further Applications. R. & M. No. 1267, British A. R. C., 1929.

TABLE I
LIFT COEFFICIENT WITHOUT PROPELLER

$$C_L = \frac{\text{Lift}}{qS}$$

Type of cowling		50 m. p. h. R. N.=2,150,000				75 m. p. h. R. N.=3,220,000				100 m. p. h. R. N.=4,300,000				
		-5°	0°	+5°	10°	-5°	0°	+5°	10°	-5°	0°	+5°	10°	12°
Nacelle position B, side brackets removed														
Small nacelle	Exposed cylinders.....	0.180	0.429	0.674	0.880	0.160	0.390	0.630	0.843	0.149	0.385	0.620	0.837	0.890
	N. A. C. A. hood.....	.179	.420	.662	.905	.152	.402	.640	.890	.152	.400	.643	.889	.988
	Ring 3, position 2.....	.176	.408	.642	.875	.163	.393	.633	.872	.144	.383	.625	.868	.965
	Ring 3, position 3.....	.160	.398	.628	.865	.156	.392	.627	.865	.148	.385	.625	.865	.955
	Ring 1, position 2.....	.173	.405	.640	.873	.161	.395	.630	.868	.150	.388	.625	.862	.952
	Ring 1, position 3.....	.169	.400	.635	.870	.161	.394	.630	.864	.152	.385	.622	.855	.951
	Variable ring -8°.....	.165	.395	.623	.851	.156	.385	.617	.847	.144	.377	.609	.842	.936
N. A. C. A. cowl.....	.189	.427	.664	.902	.174	.417	.659	.902	.154	.403	.652	.902	1.004	
Nacelle position B, with side brackets														
S. N.	Exposed cylinders.....	0.172	0.405	0.605	0.773	0.168	0.400	0.600	0.769	0.160	0.390	0.593	0.760	0.806
	N. A. C. A. hood.....	.165	.413	.600	.908	.150	.400	.648	.900	.130	.383	.633	.885	.978
	Ring 3, position 2.....	.172	.407	.643	.882	.165	.398	.637	.877	.150	.389	.628	.868	.962
Nacelle position B-1-A, faired into wing														
S. N.	Exposed cylinders.....	0.168	0.391	0.615	0.828	0.161	0.385	0.611	0.825	0.151	0.377	0.605	0.821	0.893
	N. A. C. A. hood.....	.170	.408	.644	.885	.160	.390	.634	.876	.146	.384	.621	.863	.956
	Ring 3, position 2.....	.160	.400	.637	.875	.155	.392	.632	.867	.150	.387	.623	.856	.935
	Variable ring -8°.....	.169	.405	.640	.879	.163	.399	.635	.874	.155	.391	.629	.868	.959
	N. A. C. A. cowl.....	.197	.433	.671	.914	.183	.422	.664	.908	.163	.407	.653	.900	.996
Nacelle position B-1-A, unfaired														
N. A. C. A. cowl.....		0.182	0.403	0.621	0.821	0.166	0.388	0.609	0.814	0.141	0.368	0.593	0.804	0.871
Nacelle position A-1-B, faired into wing														
S. N.	Exposed cylinders.....	0.198	0.419	0.638	0.860	0.188	0.411	0.633	0.858	0.173	0.400	0.627	0.854	0.939
	N. A. C. A. hood.....	.169	.398	.621	.850	.166	.398	.626	.858	.161	.398	.632	.869	.952
	Ring 3, position 2.....	.180	.407	.629	.852	.173	.400	.624	.850	.160	.390	.617	.847	.927
	Variable ring -8°.....	.181	.405	.630	.854	.163	.393	.623	.853	.138	.375	.613	.852	.940
	N. A. C. A. cowl.....	.150	.388	.620	.854	.145	.381	.613	.853	.139	.372	.603	.852	.933
Nacelle position A-1-B, unfaired														
S. N.	Exposed cylinders.....	0.212	0.426	0.638	0.852	0.202	0.418	0.634	0.850	0.190	0.407	0.628	0.848	0.933
	N. A. C. A. hood.....	.175	.402	.630	.852	.173	.402	.633	.858	.170	.402	.637	.868	.958
	Ring 3, position 2.....	.190	.415	.641	.868	.181	.409	.634	.862	.168	.398	.626	.855	.945
Nacelle position A-2-B														
S. N.	Exposed cylinders.....	0.170	0.400	0.623	0.857	0.162	0.394	0.626	0.857	0.151	0.386	0.623	0.857	0.950
	N. A. C. A. hood.....	.155	.394	.631	.872	.149	.388	.627	.868	.141	.380	.621	.862	.946
	Ring 3, position 2.....	.165	.400	.637	.870	.157	.393	.630	.865	.145	.380	.618	.858	.946
	Variable ring -8°.....	.142	.384	.625	.866	.142	.384	.625	.866	.142	.384	.625	.866	.949
	N. A. C. A. cowl.....	.155	.389	.623	.855	.152	.384	.619	.850	.147	.378	.613	.844	.877
Nacelle position A-1-A, faired into wing														
N. A. C. A. cowl ¹		0.208	0.435	0.658	0.872	0.197	0.427	0.654	0.873	0.182	0.415	0.648	0.875	0.905
N. A. C. A. cowl.....		.195	.424	.651	.879	.190	.419	.646	.872	.184	.412	.639	.866	.955
Nacelle position A-1-B, faired into wing														
N. A. C. A. cowl ¹		0.155	0.391	0.625	0.860	0.147	0.383	0.619	0.855	0.135	0.370	0.610	0.848	0.945
N. A. C. A. cowl.....		.150	.388	.620	.854	.145	.381	.613	.850	.139	.372	.603	.848	.945
Wing alone														
		0.179	0.417	0.652	0.889	0.175	0.414	0.650	0.887	0.169	0.409	0.646	0.885	0.960

¹ Nose fairing removed.

TABLE II
DRAG COEFFICIENT WITHOUT PROPELLER

$$C_D = \frac{\text{Drag}}{qS}$$

Type of cowling		50 m. p. h. R. N.=2,150,000				75 m. p. h. R. N.=3,220,000				100 m. p. h. R. N.=4,300,000				
Angle of attack.....		-5°	0°	+5°	10°	-5°	0°	+5°	10°	-5°	0°	+5°	10°	12°
Nacelle position B, side brackets removed														
Small nacelle	Exposed cylinders.....	0.0325	0.0550	0.0965	0.1580	0.0310	0.0520	0.0925	0.1545	0.0300	0.0500	0.0915	0.1525	0.1830
	N. A. C. A. hood.....	.0270	.0485	.0920	.1610	.0245	.0455	.0890	.1565	.0230	.0445	.0885	.1545	.1840
	Ring 3, position 2.....	.0335	.0525	.0945	.1675	.0295	.0503	.0920	.1575	.0285	.0490	.0905	.1562	.1870
	Ring 3, position 3.....	.0315	.0525	.0925	.1573	.0295	.0500	.0905	.1560	.0285	.0490	.0900	.1560	.1840
	Ring 1, position 2.....	.0393	.0601	.1000	.1687	.0365	.0561	.0965	.1620	.0350	.0550	.0955	.1600	.1910
	Ring 1, position 3.....	.0395	.0615	.1020	.1615	.0355	.0570	.0960	.1605	.0340	.0550	.0953	.1600	.1855
	Variable ring -8°.....	.0270	.0480	.0910	.1530	.0260	.0460	.0895	.1520	.0250	.0455	.0890	.1510	.1835
	N. A. C. A. cowl.....	.0205	.0440	.0890	.1530	.0200	.0425	.0880	.1525	.0195	.0420	.0870	.1520	.1830
Nacelle position B, with side brackets														
S. N.	Exposed cylinders.....	0.0320	0.0544	0.0952	0.1675	0.0295	0.0515	0.0920	0.1630	0.0291	0.0507	0.0905	0.1618	0.1920
	N. A. C. A. hood.....	.0255	.0485	.0960	.1645	.0245	.0460	.0920	.1600	.0235	.0458	.0910	.1585	.1900
	Ring 3, position 2.....	.0306	.0525	.0980	.1683	.0287	.0500	.0945	.1615	.0283	.0483	.0927	.1593	.1910
Nacelle position B-1-A, faired into wing														
S. N.	Exposed cylinders.....	0.0315	0.0555	0.0990	0.1640	0.0305	0.0545	0.0980	0.1625	0.0300	0.0545	0.0980	0.1605	0.1925
	N. A. C. A. hood.....	.0270	.0520	.0980	.1680	.0260	.0495	.0955	.1640	.0250	.0485	.0940	.1620	.1930
	Ring 3, position 2.....	.0335	.0552	.1015	.1695	.0305	.0530	.0985	.1667	.0300	.0515	.0975	.1660	.1960
	Variable ring -8°.....	.0280	.0530	.0980	.1720	.0270	.0510	.0965	.1670	.0270	.0500	.0955	.1660	.1950
	N. A. C. A. cowl.....	.0230	.0480	.0965	.1620	.0220	.0470	.0945	.1610	.0220	.0455	.0940	.1605	.1910
Nacelle position B-1-A, unfaired														
N. A. C. A. cowl.....		0.0300	0.0580	0.1100	0.1795	0.0290	0.0565	0.1070	0.1775	0.0280	0.0545	0.1060	0.1740	0.2055
Nacelle position A-1-B, faired into wing														
S. N.	Exposed cylinders.....	0.0440	0.0575	0.0915	0.1450	0.0435	0.0550	0.0910	0.1450	0.0440	0.0555	0.0905	0.1450	0.1730
	N. A. C. A. hood.....	.0355	.0510	.0880	.1440	.0340	.0505	.0865	.1430	.0335	.0495	.0860	.1420	.1705
	Ring 3, position 2.....	.0410	.0533	.0910	.1446	.0385	.0520	.0886	.1446	.0380	.0520	.0875	.1447	.1720
	Variable ring -8°.....	.0405	.0530	.0880	.1465	.0385	.0505	.0865	.1460	.0380	.0500	.0860	.1460	.1750
	N. A. C. A. cowl.....	.0260	.0460	.0850	.1570	.0240	.0425	.0825	.1525	.0230	.0420	.0815	.1510	.1820
Nacelle position A-1-B, unfaired														
S. N.	Exposed cylinders.....	0.0445	0.0572	0.0915	0.1495	0.0445	0.0572	0.0915	0.1470	0.0445	0.0572	0.0915	0.1460	0.1740
	N. A. C. A. hood.....	.0370	.0530	.0890	.1460	.0370	.0530	.0887	.1445	.0370	.0530	.0887	.1440	.1730
	Ring 3, position 2.....	.0445	.0560	.0937	.1510	.0420	.0562	.0910	.1480	.0403	.0550	.0907	.1460	.1740
Nacelle position A-2-B														
S. N.	Exposed cylinders.....	0.0400	0.0565	0.0930	0.1490	0.0385	0.0560	0.0930	0.1490	0.0385	0.0560	0.0930	0.1490	0.1775
	N. A. C. A. hood.....	.0340	.0520	.0900	.1500	.0315	.0490	.0890	.1480	.0310	.0490	.0885	.1480	.1760
	Ring 3, position 2.....	.0387	.0550	.0918	.1527	.0365	.0520	.0900	.1500	.0355	.0502	.0900	.1492	.1780
	Variable ring -8°.....	.0335	.0520	.0910	.1500	.0325	.0500	.0900	.1500	.0320	.0495	.0890	.1500	.1770
	N. A. C. A. cowl.....	.0245	.0455	.0825	.1410	.0240	.0440	.0825	.1410	.0235	.0425	.0820	.1410	.1720
Nacelle position A-1-A, faired into wing														
N. A. C. A. cowl. ¹		0.0267	0.0547	0.0985	0.1680	0.0253	0.0515	0.0965	0.1660	0.0252	0.0505	0.0960	0.1660	0.1980
N. A. C. A. cowl.....		.0260	.0520	.1080	.1810	.0250	.0510	.1070	.1780	.0240	.0500	.1060	.1760	.2105
Nacelle position A-1-B, faired into wing														
N. A. C. A. cowl. ¹		0.0283	0.0475	0.0825	0.1425	0.0263	0.0440	0.0820	0.1418	0.0260	0.0425	0.0820	0.1415	0.1690
N. A. C. A. cowl.....		.0260	.0460	.0850	.1570	.0240	.0425	.0825	.1525	.0230	.0420	.0815	.1510	.1820
Wing alone														
		0.0180	0.0425	0.0830	0.1440	0.0175	0.0415	0.0825	0.1440	0.0165	0.0405	0.0825	0.1440	0.1740

¹ Nose fairing removed.

TABLE III
MOMENT COEFFICIENT WITHOUT PROPELLER

$$C_m = \frac{\text{Moment}}{qSc}$$

(Moments were the same at all air speeds)

Type of nacelle		Angle of attack				
		-5°	0°	+5°	10°	12°
Nacelle position B, side brackets off						
Small nacelle	Exposed cylinders.....	-0.075	-0.065	-0.056	-0.054	-0.063
	N. A. C. A. hood.....	-.077	-.064	-.057	-.057	-.058
	Ring 3, position 2.....	-.078	-.060	-.051	-.051	-.052
	Ring 3, position 3.....	-.076	-.062	-.056	-.055	-.049
	Ring 1, position 2.....	-.075	-.062	-.053	-.052	-.053
	Ring 1, position 3.....	-.073	-.063	-.055	-.054	-.058
	Variable ring-8°.....	-.077	-.060	-.050	-.051	-.055
N. A. C. A. cowling.....	-.074	-.063	-.056	-.054	-.055	
Nacelle position B, with side brackets						
S. N.	Exposed cylinders.....	-0.077	-0.064	-0.051	-0.059	-0.060
	N. A. C. A. hood.....	-.076	-.063	-.055	-.053	-.052
	Ring 3, position 2.....	-.078	-.060	-.051	-.050	-.048
Nacelle position B-1-A, faired into wing						
S. N.	Exposed cylinders.....	-0.061	-0.052	-0.050	-0.046	-0.056
	N. A. C. A. hood.....	-.057	-.049	-.044	-.043	-.048
	Ring 3, position 2.....	-.055	-.050	-.046	-.040	-.043
	Variable ring-8°.....	-.060	-.048	-.045	-.040	-.042
	N. A. C. A. cowling.....	-.051	-.044	-.040	-.043	-.045
Nacelle position B-1-A, unfaired						
N. A. C. A. cowling.....	-0.061	-0.050	-0.045	-0.045	-0.047	
Nacelle position A-1-B, faired into wing						
S. N.	Exposed cylinders.....	-0.075	-0.065	-0.067	-0.071	-0.079
	N. A. C. A. hood.....	-.084	-.080	-.074	-.075	-.075
	Ring 3, position 2.....	-.082	-.080	-.075	-.075	-.077
	Variable ring-8°.....	-.078	-.082	-.074	-.076	-.076
	N. A. C. A. cowling.....	-.081	-.075	-.073	-.083	-.087
Nacelle position A-1-B, unfaired						
S. N.	Exposed cylinders.....	-0.069	-0.071	-0.069	-0.073	-0.078
	N. A. C. A. hood.....	-.078	-.074	-.070	-.071	-.075
	Ring 3, position 2.....	-.087	-.080	-.074	-.075	-.075
Nacelle position A-2-B						
S. N.	Exposed cylinders.....	-0.078	-0.075	-0.073	-0.072	-0.075
	N. A. C. A. hood.....	-.080	-.075	-.073	-.072	-.076
	Ring 3, position 2.....	-.084	-.077	-.069	-.075	-.075
	Variable ring-8°.....	-.082	-.074	-.075	-.075	-.074
	N. A. C. A. cowling.....	-.078	-.071	-.068	-.070	-.079

TABLE IV
THRUST COEFFICIENT

$$C_T = \frac{(T - \Delta D)}{\rho n^2 D^4}$$

Propeller No. 4412-4 feet. Set 17° at 0.75 R. Angle of attack = -5°

Type of nacelle		$\frac{V}{nD}$									
		0.1	0.2	0.3	0.4	0.5	0.6	0.7	0.8	0.9	1.0
Nacelle position B, side brackets removed											
Small nacelle	Exposed cylinders.....	0.0868	0.0823	0.0760	0.0682	0.0586	0.0476	0.0351	0.0219	0.0076	-0.0074
	N. A. C. A. hood.....	.0851	.0803	.0739	.0665	.0572	.0461	.0333	.0195	.0040	-.0130
	Ring 3, position 2.....	.0853	.0816	.0761	.0688	.0597	.0489	.0367	.0234	.0094	-.0068
	Ring 3, position 3.....	.0858	.0818	.0760	.0687	.0598	.0492	.0373	.0242	.0106	-.0043
	Ring 1, position 2.....	.0855	.0822	.0773	.0706	.0623	.0522	.0400	.0272	.0134	-.0010
	Ring 1, position 3.....	.0872	.0839	.0785	.0712	.0625	.0524	.0408	.0275	.0126	-.0033
	Variable ring-8°.....	.0894	.0843	.0778	.0697	.0603	.0496	.0380	.0247	.0101	-.0057
	N. A. C. A. cowling.....	.0852	.0805	.0741	.0665	.0570	.0463	.0339	.0208	.0050	-.0115
Nacelle position B, with side brackets											
S. N.	Exposed cylinders.....	0.0869	0.0821	0.0759	0.0680	0.0585	0.0476	0.0351	0.0215	0.0070	-0.0085
	N. A. C. A. hood.....	.0855	.0812	.0751	.0674	.0576	.0465	.0343	.0208	.0062	-.0095
	Ring 3, position 2.....	.0842	.0800	.0742	.0670	.0582	.0480	.0368	.0241	.0098	-.0060
Nacelle position B-1-A, faired into wing											
S. N.	Exposed cylinders.....	0.0882	.0832	0.0770	.0691	0.0601	0.0500	0.0388	0.0260	0.0118	-0.0035
	N. A. C. A. hood.....	.0883	.0830	.0762	.0683	.0590	.0487	.0376	.0244	.0102	-.0055
	Ring 3, position 2.....	.0862	.0819	.0759	.0685	.0594	.0491	.0378	.0248	.0105	-.0047
	Variable ring-8°.....	.0845	.0800	.0739	.0663	.0571	.0469	.0352	.0220	.0072	-.0095
	N. A. C. A. cowling.....	.0845	.0800	.0739	.0663	.0571	.0469	.0352	.0220	.0072	-.0095
Nacelle position B-1-A, unfaired											
N. A. C. A. cowling.....		0.0833	0.0782	0.0718	0.0641	0.0550	0.0448	0.0334	0.0203	0.0065	-0.0110
Nacelle position A-1-B, faired into wing											
S. N.	Exposed cylinders.....	0.0827	0.0782	0.0722	0.0646	0.0555	.0450	0.0332	0.0204	0.0073	-0.0062
	N. A. C. A. hood.....	.0824	.0773	.0711	.0637	.0548	.0442	.0429	.0208	.0080	-.0060
	Ring 3, position 2.....	.0822	.0789	.0737	.0669	.0586	.0489	.0378	.0256	.0127	-.0010
	Variable ring-8°.....	.0810	.0760	.0699	.0623	.0537	.0440	.0331	.0210	.0088	-.0038
	N. A. C. A. cowling.....	.0805	.0766	.0709	.0636	.0548	.0445	.0332	.0211	.0078	-.0072
	N. A. C. A. cowling.....	.0805	.0766	.0709	.0636	.0548	.0445	.0332	.0211	.0078	-.0072
Nacelle position A-1-B, unfaired											
S. N.	Exposed cylinders.....	0.0832	0.0792	0.0737	0.0670	0.0588	0.0492	0.0382	0.0262	0.0133	-0.0005
	N. A. C. A. hood.....	.0810	.0776	.0708	.0632	.0545	.0445	.0337	.0209	.0073	-.0077
	Ring 3, position 2.....	.0829	.0787	.0729	.0656	.0570	.0469	.0360	.0242	.0118	-.0015
Nacelle position A-2-B											
S. N.	Exposed cylinders.....	0.0897	0.0859	0.0801	0.0723	0.0628	.0512	.0380	.0237	.0074	-0.0097
	N. A. C. A. hood.....	.0901	.0855	.0788	.0703	.0604	.0483	.0349	.0202	.0040	-.0134
	Ring 3, position 2.....	.0896	.0850	.0785	.0703	.0605	.0490	.0359	.0209	.0050	-.0123
	Variable ring-8°.....	.0855	.0809	.0749	.0669	.0571	.0453	.0320	.0171	.0009	-.0167
	N. A. C. A. cowling.....	.0855	.0809	.0749	.0669	.0571	.0453	.0320	.0171	.0009	-.0167

TABLE IV—Continued
THRUST COEFFICIENT

$$C_T = \frac{(T - \Delta D)}{\rho n^2 D^4}$$

Propeller No. 4412—4 feet. Set 17° at 0.75 R. Angle of attack = 0°

Type of nacelle		$\frac{V}{nD}$									
		0.1	0.2	0.3	0.4	0.5	0.6	0.7	0.8	0.9	1.0
Nacelle position B, side brackets removed											
Small nacelle	Exposed cylinders.....	0.0851	0.0806	0.0743	0.0665	0.0570	0.0456	0.0331	0.0198	0.0054	-0.0097
	N. A. C. A. hood.....	.0846	.0796	.0728	.0648	.0553	.0443	.0318	.0182	.0027	-.0145
	Ring 3, position 2.....	.0846	.0805	.0747	.0672	.0582	.0480	.0364	.0232	.0090	-.0070
	Ring 3, position 3.....	.0850	.0808	.0749	.0673	.0582	.0480	.0360	.0230	.0087	-.0070
	Ring 1, position 2.....	.0849	.0816	.0765	.0697	.0610	.0508	.0384	.0251	.0102	-.0060
	Ring 1, position 3.....	.0859	.0830	.0780	.0712	.0621	.0507	.0388	.0258	.0110	-.0050
	Variable ring -8°.....	.0875	.0823	.0756	.0674	.0580	.0474	.0361	.0229	.0080	-.0078
	N. A. C. A. cowling.....	.0849	.0793	.0725	.0645	.0554	.0450	.0328	.0195	.0052	-.0110
Nacelle position B, with side brackets											
S. N.	Exposed cylinders.....	0.0866	0.0819	0.0754	0.0674	0.0575	0.0467	0.0345	0.0219	0.0084	-0.0053
	N. A. C. A. hood.....	.0845	.0800	.0740	.0660	.0565	.0457	.0333	.0199	.0053	-.0097
	Ring 3, position 2.....	.0839	.0796	.0735	.0656	.0569	.0466	.0350	.0222	.0078	-.0073
Nacelle position B-1-A, faired into wing											
S. N.	Exposed cylinders.....	0.0857	0.0810	0.0747	0.0670	0.0579	0.0478	0.0367	0.0238	0.0100	-0.0050
	N. A. C. A. hood.....	.0862	.0813	.0748	.0668	.0571	.0464	.0344	.0211	.0066	-.0090
	Ring 3, position 2.....	.0852	.0807	.0745	.0670	.0581	.0479	.0370	.0242	.0100	-.0050
	Variable ring -8°.....	.0854	.0806	.0741	.0662	.0571	.0467	.0353	.0225	.0077	-.0082
	N. A. C. A. cowling.....	.0843	.0790	.0722	.0640	.0542	.0436	.0319	.0190	.0045	-.0112
Nacelle position B-1-A, unfaired											
N. A. C. A. cowling.....	0.0823	0.0767	0.0699	0.0622	0.0531	0.0428	0.0314	0.0185	0.0044	-0.0110	
Nacelle position A-1-B, faired into wing											
S. N.	Exposed cylinders.....	0.0842	0.0800	0.0742	0.0670	0.0581	0.0474	0.0355	0.0222	0.0079	-0.0075
	N. A. C. A. hood.....	.0823	.0775	.0713	.0639	.0551	.0459	.0357	.0247	.0123	-.0023
	Ring 3, position 2.....	.0820	.0781	.0727	.0658	.0575	.0478	.0369	.0250	.0127	-.0067
	Variable ring -8°.....	.0813	.0761	.0698	.0620	.0530	.0440	.0342	.0233	.0120	-.0000
	N. A. C. A. cowling.....	.0805	.0765	.0709	.0635	.0550	.0449	.0339	.0222	.0098	-.0036
Nacelle position A-1-B, unfaired											
S. N.	Exposed cylinders.....	0.0822	0.0776	0.0718	0.0648	0.0565	0.0473	0.0368	0.0249	0.0118	-0.0020
	N. A. C. A. hood.....	.0807	.0762	.0706	.0629	.0545	.0452	.0351	.0241	.0110	-.0030
	Ring 3, position 2.....	.0828	.0780	.0720	.0647	.0563	.0468	.0370	.0254	.0133	-.0003
Nacelle position A-2-B											
S. N.	Exposed cylinders.....	0.0897	0.0860	0.0802	0.0728	0.0638	0.0532	0.0410	0.0277	0.0131	-0.0033
	N. A. C. A. hood.....	.0900	.0845	.0787	.0706	.0606	.0496	.0370	.0230	.0077	-.0093
	Ring 3, position 2.....	.0895	.0852	.0791	.0714	.0620	.0509	.0383	.0250	.0105	-.0050
	Variable ring -8°.....	.0907	.0859	.0793	.0710	.0614	.0501	.0375	.0237	.0083	-.0081
	N. A. C. A. cowling.....	.0861	.0813	.0750	.0672	.0575	.0464	.0338	.0201	.0053	-.0102

TABLE IV—Continued
THRUST COEFFICIENT

$$C_T = \frac{(T - \Delta D)}{\rho n^2 D^4}$$

Propeller No. 4412—4 feet. Set 17° at 0.75 R. Angle of attack = +5°

Type of nacelle		$\frac{V}{nD}$									
		0.1	0.2	0.3	0.4	0.5	0.6	0.7	0.8	0.9	1.0
Nacelle position B, side brackets removed											
Small nacelle	Exposed cylinders.....	0.0829	0.0773	0.0703	0.0620	0.0524	0.0418	0.0301	0.0180	0.0050	-0.0087
	N. A. C. A. hood.....	.0822	.0769	.0700	.0619	.0525	.0419	.0302	.0174	.0034	-.0113
	Ring 3, position 2.....	.0804	.0759	.0698	.0622	.0532	.0430	.0318	.0192	.0062	-.0075
	Ring 3, position 3.....	.0810	.0760	.0693	.0615	.0525	.0425	.0317	.0197	.0067	-.0073
	Ring 1, position 2.....	.0808	.0768	.0712	.0639	.0549	.0449	.0340	.0221	.0092	-.0048
	Ring 1, position 3.....	.0828	.0780	.0720	.0644	.0555	.0457	.0344	.0221	.0096	-.0035
	Variable ring -8°.....	.0847	.0789	.0716	.0633	.0539	.0434	.0323	.0198	.0065	-.0078
	N. A. C. A. cowling.....	.0829	.0779	.0712	.0630	.0530	.0413	.0293	.0167	.0032	-.0110
Nacelle position B, with side brackets											
S. N.	Exposed cylinders.....	0.0831	0.0772	0.0700	0.0614	0.0517	0.0410	0.0297	0.0177	0.0048	-0.0090
	N. A. C. A. hood.....	.0815	.0767	.0702	.0624	.0530	.0423	.0306	.0178	.0043	-.0100
	Ring 3, position 2.....	.0820	.0768	.0700	.0620	.0535	.0434	.0322	.0203	.0072	-.0060
Nacelle position B-1-A, faired into wing											
S. N.	Exposed cylinders.....	0.0846	0.0779	0.0701	0.0614	0.0522	0.0424	0.0318	0.0197	0.0069	-0.0070
	N. A. C. A. hood.....	.0818	.0762	.0694	.0611	.0517	.0413	.0297	.0170	.0035	-.0110
	Ring 3, position 2.....	.0834	.0782	.0716	.0634	.0540	.0433	.0319	.0196	.0066	-.0067
	Variable ring -8°.....	.0824	.0771	.0704	.0623	.0530	.0428	.0315	.0193	.0067	-.0070
	N. A. C. A. cowling.....	.0820	.0765	.0696	.0611	.0513	.0407	.0287	.0157	.0021	-.0125
Nacelle position B-1-A, unfaired											
	N. A. C. A. cowling.....	0.0308	0.0751	0.0681	0.0599	0.0506	0.0404	0.0294	0.0168	0.0035	-0.0102
Nacelle position A-1-B, faired into wing											
S. N.	Exposed cylinders.....	0.0824	0.0774	0.0712	0.0640	0.0559	0.0471	0.0379	0.0279	0.0175	0.0063
	N. A. C. A. hood.....	.0807	.0752	.0689	.0612	.0525	.0428	.0325	.0217	.0105	-.0014
	Ring 3, position 2.....	.0810	.0763	.0705	.0634	.0551	.0460	.0360	.0254	.0143	.0028
	Variable ring -8°.....	.0805	.0762	.0705	.0633	.0548	.0452	.0347	.0236	.0118	-.0005
	N. A. C. A. cowling.....	.0796	.0775	.0699	.0627	.0533	.0437	.0338	.0231	.0123	.0005
Nacelle position A-1-B, unfaired											
S. N.	Exposed cylinders.....	0.0803	0.0754	0.0692	0.0621	0.0540	0.0450	.0352	0.0242	0.0126	0.0000
	N. A. C. A. hood.....	.0796	.0747	.0680	.0600	.0512	.0422	.0326	.0225	.0115	.0003
	Ring 3, position 2.....	.0810	.0763	.0698	.0618	.0532	.0445	.0353	.0253	.0145	.0030
Nacelle position A-2-B											
S. N.	Exposed cylinders.....	0.0897	0.0859	0.0797	0.0713	0.0621	0.0520	0.0404	0.0280	0.0149	0.0007
	N. A. C. A. hood.....	.0884	.0837	.0774	.0697	.0605	.0500	.0385	.0262	.0129	-.0015
	Ring 3, position 2.....	.0884	.0836	.0773	.0698	.0608	.0506	.0395	.0274	.0149	.0015
	Variable ring -8°.....	.0878	.0830	.0767	.0690	.0602	.0504	.0396	.0279	.0156	.0015
	N. A. C. A. cowling.....	.0854	.0807	.0741	.0662	.0571	.0462	.0349	.0229	.0105	-.0024

TABLE IV—Continued
THRUST COEFFICIENT

$$C_T = \frac{(T - \Delta D)}{\rho n^2 D^4}$$

Propeller No. 4412—4 feet. Set 17° at 0.75 R. Angle of attack = +10°

Type of nacelle		$\frac{V}{nD}$									
		0.1	0.2	0.3	0.4	0.5	0.6	0.7	0.8	0.9	1.0
Nacelle position B, side brackets removed											
Small nacelle	Exposed cylinders.....	0.0790	0.0720	0.0640	0.0552	0.0457	0.0359	0.0252	0.0142	0.0031	-0.0079
	N. A. C. A. hood.....	.0784	.0723	.0651	.0570	.0479	.0382	.0280	.0170	.0052	-.0075
	Ring 3, position 2.....	.0786	.0724	.0651	.0570	.0478	.0382	.0280	.0170	.0055	-.0067
	Ring 3, position 3.....	.0776	.0716	.0645	.0564	.0477	.0382	.0285	.0179	.0065	-.0053
	Ring 1, position 2.....	.0771	.0728	.0670	.0597	.0510	.0414	.0308	.0198	.0081	-.0045
	Ring 1, position 3.....	.0782	.0718	.0649	.0570	.0490	.0404	.0310	.0208	.0100	-.0015
	Variable ring -8°.....	.0822	.0753	.0674	.0587	.0495	.0398	.0295	.0187	.0079	-.0032
N. A. C. A. cowling.....	.0798	.0738	.0660	.0572	.0480	.0380	.0275	.0161	.0041	-.0100	
Nacelle position B, with side brackets											
S. N.	Exposed cylinders.....	0.0800	0.0740	0.0670	0.0589	0.0498	0.0401	0.0299	0.0190	0.0080	-0.0035
	N. A. C. A. hood.....	.0785	.0726	.0652	.0570	.0475	.0373	.0267	.0151	.0031	-.0097
	Ring 3, position 2.....	.0798	.0740	.0666	.0581	.0484	.0381	.0274	.0161	.0031	-.0077
Nacelle position B-1-A, faired into wing											
S. N.	Exposed cylinders.....	0.0833	0.0762	0.0678	0.0583	0.0480	0.0370	0.0257	0.0140	0.0020	-0.0100
	N. A. C. A. hood.....	.0795	.0737	.0664	.0579	.0482	.0375	.0260	.0136	.0005	-.0132
	Ring 3, position 2.....	.0301	.0740	.0665	.0578	.0481	.0378	.0270	.0156	.0037	-.0085
	Variable ring -8°.....	.0801	.0747	.0676	.0592	.0498	.0392	.0280	.0161	.0038	-.0088
	N. A. C. A. cowling.....	.0786	.0722	.0645	.0559	.0461	.0353	.0249	.0120	-.0025	-.0183
Nacelle position B-1-A, unfaired											
N. A. C. A. cowling.....	0.0776	0.0718	0.0646	0.0564	0.0471	0.0368	0.0254	0.0128	-0.0006	-0.0148	
Nacelle position A-1-B, faired into wing											
S. N.	Exposed cylinders.....	0.0805	0.0748	0.0679	0.0602	0.0516	0.0426	0.0335	0.0239	0.0141	0.0044
	N. A. C. A. hood.....	.0778	.0712	.0640	.0562	.0481	.0396	.0307	.0215	.0118	.0017
	Ring 3, position 2.....	.0782	.0728	.0662	.0590	.0510	.0427	.0338	.0242	.0145	.0050
	Variable ring -8°.....	.0790	.0740	.0680	.0605	.0526	.0436	.0341	.0240	.0131	.0020
	N. A. C. A. cowling.....										
Nacelle position A-1-B, unfaired											
S. N.	Exposed cylinders.....	0.0781	0.0730	0.0667	0.0591	0.0504	0.0407	0.0305	0.0199	0.0089	-0.0025
	N. A. C. A. hood.....	.0790	.0734	.0670	.0594	.0506	.0411	.0315	.0216	.0110	-.0004
	Ring 3, position 2.....	.0779	.0718	.0648	.0573	.0495	.0411	.0322	.0230	.0140	.0050
Nacelle position A-2-B											
S. N.	Exposed cylinders.....	0.0895	0.0850	0.0781	0.0692	0.0592	0.0486	0.0372	0.0253	0.0130	0.
	N. A. C. A. hood.....	.0863	.0812	.0747	.0668	.0576	.0479	.0378	.0265	.0145	.0002
	Ring 3, position 2.....	.0874	.0823	.0758	.0679	.0591	.0494	.0391	.0284	.0170	.0051
	Variable ring -8°.....	.0863	.0812	.0747	.0672	.0585	.0490	.0390	.0281	.0170	.0051
	N. A. C. A. cowling.....	.0837	.0777	.0707	.0629	.0541	.0450	.0352	.0251	.0149	.0044

TABLE V.—POWER COEFFICIENT

$$C_P = \frac{P}{\rho n^3 D^5}$$

Propeller No. 4412—4 feet. Set 17° at 0.75 R. Angle of attack = -5°

Type of nacelle		$\frac{V}{nD}$									
		0.1	0.2	0.3	0.4	0.5	0.6	0.7	0.8	0.9	1.0
Nacelle position B, side brackets removed											
Small nacelle	Exposed cylinders.....	0.0431	0.0432	0.0427	0.0415	0.0393	0.0358	0.0303	0.0229	0.0130	0.0007
	N. A. C. A. hood.....	.0425	.0422	.0419	.0411	.0396	.0362	.0305	.0226	.0122	-.0005
	Ring 3, position 2.....	.0430	.0426	.0421	.0411	.0391	.0360	.0313	.0239	.0140	.0018
	Ring 3, position 3.....	.0440	.0440	.0434	.0420	.0399	.0366	.0315	.0240	.0146	.0028
	Ring 1, position 2.....	.0437	.0435	.0429	.0416	.0395	.0363	.0312	.0243	.0153	.0040
	Ring 1, position 3.....	.0437	.0431	.0423	.0410	.0391	.0361	.0317	.0249	.0155	.0040
	Variable ring -8°.....	.0437	.0437	.0432	.0420	.0400	.0370	.0324	.0253	.0155	.0033
	N. A. C. A. cowling.....	.0425	.0422	.0418	.0410	.0390	.0355	.0300	.0227	.0121	-.0003
Nacelle position B, with side brackets											
S. N.	Exposed cylinders.....	0.0443	0.0440	0.0432	0.0419	0.0399	0.0369	0.0317	0.0237	0.0132	0.0000
	N. A. C. A. hood.....	.0435	.0434	.0428	.0413	.0390	.0353	.0300	.0221	.0121	.0003
	Ring 3, position 2.....	.0437	.0434	.0428	.0414	.0392	.0360	.0307	.0233	.0136	.0024
Nacelle position B-1-A, faired into wing											
S. N.	Exposed cylinders.....	0.0450	0.0445	0.0438	0.0425	0.0404	0.0372	0.0325	0.0256	0.0163	0.0050
	N. A. C. A. hood.....	.0448	.0444	.0437	.0422	.0400	.0369	.0320	.0250	.0158	.0044
	Ring 3, position 2.....	.0441	.0438	.0430	.0416	.0395	.0364	.0319	.0250	.0157	.0040
	Variable ring -8°.....	.0433	.0427	.0420	.0407	.0391	.0362	.0312	.0238	.0145	.0026
	N. A. C. A. cowling.....	.0433	.0427	.0420	.0407	.0391	.0362	.0312	.0238	.0145	.0026
Nacelle position B-1-A, unfaired											
N. A. C. A. cowling.....		0.0425	0.0423	0.0419	0.0411	0.0392	0.0361	0.0312	0.0237	0.0136	0.0012
Nacelle position A-1-B, faired into wing											
S. N.	Exposed cylinders.....	0.0427	0.0425	0.0421	0.0413	0.0400	0.0373	0.0333	0.0274	0.0194	0.0092
	N. A. C. A. hood.....	.0430	.0430	.0427	.0420	.0403	.0374	.0328	.0262	.0171	.0065
	Ring 3, position 2.....	.0430	.0430	.0426	.0415	.0398	.0370	.0326	.0262	.0173	.0063
	Variable ring -8°.....	.0428	.0432	.0430	.0423	.0408	.0380	.0335	.0270	.0184	.0075
	N. A. C. A. cowling.....	.0439	.0436	.0430	.0421	.0401	.0370	.0325	.0256	.0167	.0057
Nacelle position A-1-B, unfaired											
S. N.	Exposed cylinders.....	0.0436	0.0434	0.0430	0.0420	0.0402	0.0375	0.0336	0.0277	0.0198	0.0105
	N. A. C. A. hood.....	.0439	.0439	.0435	.0420	.0399	.0367	.0323	.0260	.0175	.0070
	Ring 3, position 2.....	.0435	.0434	.0432	.0424	.0404	.0375	.0329	.0267	.0186	.0081
Nacelle position A-2-B											
S. N.	Exposed cylinders.....	.0440	.0436	.0430	.0420	.0398	.0364	.0310	.0231	.0143	.0018
	N. A. C. A. hood.....	.0451	.0449	.0446	.0435	.0414	.0377	.0318	.0232	.0127	.0000
	Ring 3, position 2.....	.0456	.0458	.0451	.0438	.0412	.0370	.0313	.0232	.0125	-.0007
	Variable ring -8°.....	.0439	.0440	.0434	.0419	.0396	.0353	.0290	.0202	.0104	-.0020
	N. A. C. A. cowling.....	.0439	.0440	.0434	.0419	.0396	.0353	.0290	.0202	.0104	-.0020

TABLE V.—POWER COEFFICIENT—Continued

$$C_P = \frac{P}{\rho n^3 D^5}$$

Propeller No. 4412—4 feet. Set 17° at 0.75 R. Angle of attack = 0°

Type of nacelle		$\frac{V}{n D}$									
		0.1	0.2	0.3	0.4	0.5	0.6	0.7	0.8	0.9	1.0
Nacelle position B, side brackets removed											
Small nacelle	Exposed cylinders	0.0430	0.0431	0.0427	0.0415	0.0391	0.0354	0.0301	0.0229	0.0130	0.0009
	N. A. C. A. hood0426	.0425	.0421	.0410	.0390	.0355	.0302	.0221	.0116	-.0018
	Ring 3, position 20434	.0433	.0428	.0415	.0395	.0363	.0313	.0237	.0137	.0010
	Ring 3, position 30441	.0443	.0440	.0428	.0407	.0371	.0315	.0239	.0140	.0015
	Ring 1, position 20437	.0433	.0426	.0416	.0397	.0365	.0317	.0249	.0159	.0046
	Ring 1, position 30433	.0431	.0429	.0420	.0399	.0365	.0318	.0249	.0156	.0043
	Variable ring -8°0433	.0434	.0429	.0417	.0398	.0366	.0320	.0248	.0150	.0023
	N. A. C. A. cowling0427	.0423	.0418	.0408	.0390	.0360	.0305	.0226	.0125	-.0005
Nacelle position B, with side brackets											
S. N.	Exposed cylinders	0.0446	0.0443	0.0435	0.0420	0.0399	0.0366	0.0314	0.0240	0.0137	0.0004
	N. A. C. A. hood0436	.0438	.0432	.0420	.0396	.0361	.0306	.0227	.0125	.0000
	Ring 3, position 20432	.0431	.0424	.0411	.0391	.0359	.0306	.0230	.0132	.0016
Nacelle position B-1-A, faired into wing											
S. N.	Exposed cylinders	0.0450	0.0449	0.0443	0.0430	0.0410	0.0377	0.0326	0.0251	0.0155	0.0037
	N. A. C. A. hood0450	.0452	.0448	.0437	.0416	.0377	.0321	.0245	.0146	.0025
	Ring 3, position 20445	.0442	.0435	.0420	.0399	.0365	.0317	.0245	.0150	.0030
	Variable ring -8°0442	.0440	.0432	.0418	.0397	.0365	.0315	.0244	.0150	.0033
	N. A. C. A. cowling0435	.0429	.0422	.0412	.0394	.0360	.0306	.0231	.0131	.0000
Nacelle position B-1-A, unfaired											
N. A. C. A. cowling		0.0425	0.0423	0.0419	0.0409	0.0392	0.0361	0.0308	0.0234	0.0137	0.0011
Nacelle position A-1-B, faired into wing											
S. N.	Exposed cylinders	0.0426	0.0423	0.0419	0.0412	0.0401	0.0380	0.0340	0.0278	0.0196	0.0094
	N. A. C. A. hood0430	.0430	.0425	.0418	.0403	.0378	.0337	.0276	.0189	.0080
	Ring 3, position 20431	.0432	.0431	.0422	.0405	.0380	.0339	.0276	.0190	.0077
	Variable ring -8°0429	.0431	.0430	.0422	.0407	.0380	.0338	.0273	.0191	.0090
	N. A. C. A. cowling0440	.0438	.0432	.0423	.0406	.0377	.0333	.0273	.0190	.0086
Nacelle position A-1-B, unfaired											
S. N.	Exposed cylinders	0.0436	0.0434	0.0430	0.0421	0.0404	0.0379	0.0340	0.0279	0.0195	0.0096
	N. A. C. A. hood0435	.0440	.0436	.0409	.0401	.0376	.0336	.0275	.0190	.0085
	Ring 3, position 20435	.0434	.0430	.0423	.0411	.0386	.0346	.0283	.0200	.0100
Nacelle position A-2-B											
S. N.	Exposed cylinders	0.0440	0.0440	0.0438	0.0428	0.0408	0.0374	0.0322	0.0252	0.0155	0.0043
	N. A. C. A. hood0450	.0445	.0439	.0429	.0413	.0386	.0337	.0260	.0160	.0035
	Ring 3, position 20442	.0442	.0437	.0424	.0403	.0372	.0323	.0251	.0160	.0045
	Variable ring -8°0455	.0453	.0447	.0435	.0415	.0383	.0337	.0257	.0160	.0038
	N. A. C. A. cowling0438	.0439	.0433	.0420	.0399	.0361	.0309	.0230	.0132	.0016

TABLE V.—POWER COEFFICIENT—Continued

$$C_P = \frac{P}{\rho n^2 D^5}$$

Propeller No. 4412—4 feet. Set 17° at 0.75 R. Angle of attack = +5°

Type of nacelle		$\frac{V}{n D}$									
		0.1	0.2	0.3	0.4	0.5	0.6	0.7	0.8	0.9	1.0
Nacelle position B, side brackets removed											
Small nacelle	Exposed cylinders.....	0.0440	0.0439	0.0432	0.0416	0.0396	0.0354	0.0300	0.0226	0.0125	-0.0003
	N. A. C. A. hood.....	.0439	.0437	.0430	.0417	.0396	.0357	.0299	.0220	.0117	-.0011
	Ring 3, position 2.....	.0439	.0437	.0430	.0416	.0395	.0361	.0311	.0234	.0136	.0015
	Ring 3, position 3.....	.0437	.0438	.0432	.0420	.0396	.0360	.0305	.0233	.0140	.0023
	Ring 1, position 2.....	.0437	.0434	.0431	.0420	.0394	.0355	.0309	.0240	.0147	.0037
	Ring 1, position 3.....	.0434	.0434	.0430	.0421	.0399	.0363	.0316	.0245	.0154	.0045
	Variable ring -8°.....	.0443	.0440	.0433	.0418	.0395	.0360	.0310	.0238	.0145	.0033
N. A. C. A. cowling.....	.0431	.0430	.0424	.0412	.0388	.0351	.0295	.0221	.0120	-.0005	
Nacelle position B, with side brackets											
S. N.	Exposed cylinders.....	0.0445	0.0441	0.0433	0.0419	0.0394	0.0360	0.0310	0.0234	0.0134	0.0005
	N. A. C. A. hood.....	.0438	.0438	.0431	.0416	.0393	.0355	.0300	.0219	.0118	.0000
	Ring 3, position 2.....	.0439	.0437	.0430	.0420	.0398	.0359	.0302	.0230	.0140	.0031
Nacelle position B-1-A, faired into wing											
S. N.	Exposed cylinders.....	0.0445	0.0447	0.0442	0.0429	0.0405	0.0369	0.0315	0.0239	0.0138	0.0014
	N. A. C. A. hood.....	.0442	.0442	.0436	.0423	.0401	.0365	.0311	.0234	.0132	.0005
	Ring 3, position 2.....	.0445	.0445	.0439	.0426	.0404	.0371	.0319	.0244	.0148	.0028
	Variable ring -8°.....	.0445	.0442	.0436	.0421	.0398	.0360	.0307	.0232	.0139	.0025
	N. A. C. A. cowling.....	.0434	.0429	.0421	.0412	.0393	.0358	.0302	.0222	.0119	-.0013
Nacelle position B-1-A, unfaired											
N. A. C. A. cowling.....		0.0425	0.0422	0.0418	0.0407	0.0388	0.0356	0.0305	0.0228	0.0128	0.0003
Nacelle position A-1-B, faired into wing											
S. N.	Exposed cylinders.....	0.0427	0.0426	0.0423	0.0416	0.0403	0.0380	0.0341	0.0286	0.0209	0.0114
	N. A. C. A. hood.....	.0433	.0431	.0427	.0418	.0404	.0382	.0345	.0285	.0205	.0110
	Ring 3, position 2.....	.0429	.0430	.0426	.0417	.0402	.0378	.0342	.0288	.0211	.0112
	Variable ring -8°.....	.0427	.0431	.0432	.0426	.0412	.0388	.0350	.0292	.0212	.0113
	N. A. C. A. cowling.....	.0432	.0429	.0423	.0414	.0400	.0378	.0338	.0284	.0208	.0115
Nacelle position A-1-B, unfaired											
S. N.	Exposed cylinders.....	0.0436	0.0435	0.0431	0.0424	0.0410	0.0383	0.0344	0.0288	0.0210	0.0102
	N. A. C. A. hood.....	.0437	.0440	.0436	.0424	.0404	.0379	.0342	.0290	.0213	.0113
	Ring 3, position 2.....	.0434	.0432	.0428	.0423	.0412	.0386	.0345	.0285	.0211	.0105
Nacelle position A-2-B											
S. N.	Exposed cylinders.....	0.0440	0.0440	0.0438	0.0431	0.0415	0.0385	0.0337	0.0268	0.0180	0.0078
	N. A. C. A. hood.....	.0452	.0451	.0448	.0439	.0423	.0390	.0343	.0277	.0188	.0076
	Ring 3, position 2.....	.0447	.0451	.0447	.0439	.0421	.0390	.0342	.0274	.0186	.0080
	Variable ring -8°.....	.0448	.0447	.0441	.0430	.0410	.0384	.0342	.0280	.0193	.0075
	N. A. C. A. cowling.....	.0439	.0440	.0432	.0421	.0400	.0366	.0318	.0250	.0166	.0064

TABLE V.—POWER COEFFICIENT—Continued

$$C_P = \frac{P}{\rho n^3 D^5}$$

Propeller No. 4412-4 feet. Set 17° at 0.75 R. Angle of attack = +10°.

Type on nacelle		$\frac{V}{n D}$									
		0.1	0.2	0.3	0.4	0.5	0.6	0.7	0.8	0.9	1.0
Nacelle position B, side brackets removed											
S. N.	Exposed cylinders	0.0439	0.0438	0.0432	0.0420	0.0397	0.0362	0.0307	0.0232	0.0137	0.0018
	N. A. C. A. hood	.0433	.0433	.0428	.0417	.0396	.0362	.0309	.0229	.0135	.0023
	Ring 3, position 2	.0439	.0436	.0430	.0417	.0396	.0365	.0317	.0247	.0152	.0034
	Ring 3, position 3	.0432	.0434	.0431	.0422	.0402	.0370	.0324	.0253	.0160	.0046
	Ring 1, position 2	.0437	.0434	.0430	.0420	.0401	.0371	.0322	.0257	.0168	.0055
	Ring 1, position 3	.0424	.0424	.0421	.0415	.0399	.0371	.0324	.0253	.0163	.0052
	Variable ring-8°	.0448	.0449	.0443	.0431	.0410	.0375	.0322	.0253	.0167	.0065
	N. A. C. A. cowling	.0428	.0423	.0418	.0405	.0389	.0358	.0301	.0230	.0131	.0017
Nacelle position B, with side brackets											
S. N.	Exposed cylinders	0.0443	0.0446	0.0442	0.0430	0.0409	0.0374	0.0324	0.0252	0.0160	0.0045
	N. A. C. A. hood	.0437	.0438	.0432	.0420	.0397	.0361	.0306	.0230	.0138	.0020
	Ring 3, position 2	.0433	.0430	.0424	.0412	.0393	.0363	.0312	.0242	.0153	.0043
Nacelle position B-1-A, faired into wing											
S. N.	Exposed cylinders	0.0445	0.0447	0.0442	0.0430	0.0410	0.0376	0.0324	0.0250	0.0150	0.0027
	N. A. C. A. hood	.0443	.0443	.0439	.0424	.0402	.0366	.0310	.0232	.0133	.0005
	Ring 3, position 2	.0441	.0442	.0437	.0425	.0404	.0371	.0317	.0246	.0153	.0035
	Variable ring-8°	.0444	.0444	.0439	.0425	.0404	.0363	.0309	.0234	.0140	.0025
	N. A. C. A. cowling	.0434	.0430	.0425	.0417	.0398	.0359	.0303	.0223	.0116	.0020
Nacelle position B-1-A, unfaired											
	N. A. C. A. cowling	0.0425	0.0422	0.0416	0.0404	0.0385	0.0352	0.0302	0.0227	0.0124	0.0000
Nacelle position A-1-B, faired into wing											
S. N.	Exposed cylinders	0.0427	0.0426	0.0426	0.0422	0.0411	0.0392	0.0362	0.0310	0.0237	0.0145
	N. A. C. A. hood	.0428	.0426	.0423	.0418	.0410	.0392	.0360	.0305	.0231	.0138
	Ring 3, position 2	.0428	.0432	.0432	.0427	.0416	.0394	.0362	.0309	.0240	.0151
	Variable ring-8°	.0428	.0434	.0437	.0432	.0421	.0400	.0367	.0315	.0244	.0155
	N. A. C. A. cowling	.0425	.0423	.0421	.0417	.0408	.0393	.0366	.0313	.0240	.0147
Nacelle position A-1-B, unfaired											
S. N.	Exposed cylinders	0.0436	0.0436	0.0432	0.0424	0.0411	0.0390	0.0354	0.0302	0.0234	0.0146
	N. A. C. A. hood	.0437	.0437	.0436	.0426	.0411	.0387	.0360	.0305	.0235	.0144
	Ring 3, position 2	.0435	.0434	.0430	.0425	.0415	.0397	.0363	.0312	.0242	.0153
Nacelle position A-2-B											
S. N.	Exposed cylinders	0.0440	0.0440	0.0439	0.0433	0.0422	0.0399	0.0359	0.0297	0.0220	0.0123
	N. A. C. A. hood	.0455	.0451	.0447	.0438	.0426	.0404	.0368	.0308	.0226	.0130
	Ring 3, position 2	.0447	.0450	.0447	.0439	.0424	.0401	.0365	.0309	.0233	.0140
	Variable ring-8°	.0453	.0455	.0452	.0443	.0428	.0402	.0365	.0309	.0230	.0133
	N. A. C. A. cowling	.0437	.0439	.0436	.0427	.0410	.0381	.0340	.0280	.0206	.0110

TABLE VI.—PROPULSIVE EFFICIENCY

$$\eta = \frac{(T - \Delta D)V}{P}$$

Propeller No. 4412-4 feet. Set 17° at 0.75 R. Angle of attack = -5°

Type of nacelle		$\frac{V}{nD}$									
		0.1	0.2	0.3	0.4	0.5	0.6	0.7	0.8	0.9	1.0
Nacelle position B, side brackets removed											
Small nacelle	Exposed cylinders.....	0.201	0.381	0.534	0.658	0.745	0.798	0.810	0.765	0.526	-----
	N. A. C. A. hood.....	.200	.380	.529	.647	.722	.765	.815	.690	.295	-----
	Ring 3, position 2.....	.198	.383	.542	.670	.763	.815	.820	.783	.603	-----
	Ring 3, position 3.....	.195	.372	.525	.654	.750	.807	.829	.807	.653	-----
	Ring 1, position 2.....	.196	.378	.540	.679	.789	.863	.898	.894	.789	-----
	Ring 1, position 3.....	.199	.387	.557	.695	.800	.870	.901	.884	.731	-----
	Variable ring -8°.....	.204	.385	.540	.664	.754	.804	.821	.780	.586	-----
N. A. C. A. cowling.....	.200	.381	.532	.649	.731	.783	.792	.735	.372	-----	
Nacelle position B, with side brackets											
S. N.	Exposed cylinders.....	0.196	0.373	0.527	0.649	0.733	0.774	0.775	0.726	0.477	-----
	N. A. C. A. hood.....	.197	.374	.526	.652	.740	.790	.800	.750	.461	-----
	Ring 3, position 2.....	.193	.369	.519	.647	.740	.801	.837	.829	.649	-----
Nacelle position B-1-A, faired into wing											
S. N.	Exposed cylinders.....	0.196	0.374	0.526	0.651	0.744	0.806	0.835	0.813	0.651	-----
	N. A. C. A. hood.....	.197	.375	.524	.646	.739	.792	.823	.781	.581	-----
	Ring 3, position 2.....	.196	.374	.529	.658	.752	.809	.830	.794	.601	-----
	Variable ring -8°.....	.195	.375	.528	.651	.730	.778	.790	.740	.447	-----
	N. A. C. A. cowling.....	.195	.375	.528	.651	.730	.778	.790	.740	.447	-----
Nacelle position B-1-A, unfaired											
	N. A. C. A. cowling.....	0.196	0.370	0.514	0.625	0.701	0.745	0.750	0.685	0.430	-----
Nacelle position A-1-B, faired into wing											
N. S.	Exposed cylinders.....	.0194	0.368	0.514	0.626	0.694	0.724	0.698	0.596	0.339	-----
	N. A. C. A. hood.....	.192	.360	.500	.606	.680	.710	.701	.635	.420	-----
	Ring 3, position 2.....	.191	.367	.519	.645	.736	.793	.811	.781	.661	-----
	Variable Ring -8°.....	.189	.352	.487	.590	.659	.695	.693	.624	.430	-----
	N. A. C. A. cowling.....	.183	.351	.494	.604	.683	.721	.715	.660	.420	-----
Nacelle position A-1-B, unfaired											
N. S.	Exposed cylinders.....	0.191	0.365	0.514	0.638	0.731	0.788	0.796	0.757	0.605	-----
	N. A. C. A. hood.....	.185	.351	.488	.601	.684	.729	.730	.638	.375	-----
	Ring 3, position 2.....	.191	.363	.506	.619	.705	.750	.766	.725	.571	-----
Nacelle position A-2-B											
N. S.	Exposed cylinders.....	0.204	0.394	0.559	0.688	0.789	0.845	0.858	0.821	0.465	-----
	N. A. C. A. hood.....	.200	.381	.530	.646	.730	.770	.768	.696	.284	-----
	Ring 3, position 2.....	.197	.371	.522	.642	.735	.795	.802	.720	.360	-----
	Variable ring -8°.....	.194	.368	.516	.639	.720	.770	.771	.675	.120	-----
	N. A. C. A. cowling.....	.194	.368	.516	.639	.720	.770	.771	.675	.120	-----

TABLE VI.—PROPULSIVE EFFICIENCY—Continued

$$\eta = \frac{(T - \Delta D) V}{P}$$

Propeller No. 4412—4 feet. Set 17° at 0.75 R. Angle of attack=0°

Type of nacelle		$\frac{V}{nD}$									
		0.1	0.2	0.3	0.4	0.5	0.6	0.7	0.8	0.9	1.0
Nacelle position B, side brackets removed											
S. N.	Exposed cylinders.....	0.198	0.373	0.521	0.641	0.729	0.774	0.770	0.691	0.373	-----
	N. A. C. A. hood.....	.199	.374	.519	.631	.709	.748	.737	.658	.209	-----
	Ring 3, position 2.....	.195	.372	.523	.647	.737	.794	.814	.783	.590	-----
	Ring 3, position 3.....	.192	.365	.510	.629	.715	.776	.800	.770	.560	-----
	Ring 1, position 2.....	.194	.377	.538	.670	.768	.830	.848	.807	.577	-----
	Ring 1, position 3.....	.198	.385	.546	.678	.779	.834	.853	.830	.634	-----
	Variable ring -8°.....	.202	.379	.529	.646	.728	.777	.790	.739	.480	-----
N. A. C. A. cowling.....	.198	.375	.521	.632	.710	.750	.752	.690	.374	-----	
Nacelle position B, with side brackets											
S. N.	Exposed cylinders.....	0.194	0.370	0.520	0.642	0.721	0.765	0.769	0.730	0.552	-----
	N. A. C. A. hood.....	.194	.369	.514	.629	.713	.760	.761	.701	.382	-----
	Ring 3, position 2.....	.194	.369	.520	.639	.727	.780	.800	.770	.532	-----
Nacelle position B-1-A, faired into wing											
S. N.	Exposed cylinders.....	0.190	0.361	0.530	0.623	0.706	0.761	0.787	0.760	0.580	-----
	N. A. C. A. hood.....	.192	.360	.501	.611	.686	.739	.750	.688	.406	-----
	Ring 3, position 2.....	.192	.365	.513	.638	.728	.787	.817	.790	.600	-----
	Variable ring -8°.....	.193	.366	.515	.633	.719	.768	.784	.737	.462	-----
	N. A. C. A. cowling.....	.194	.368	.513	.621	.687	.727	.728	.658	.309	-----
Nacelle position B-1-A, unfaired											
N. A. C. A. cowling.....	0.194	0.362	0.501	0.608	0.677	0.713	0.714	0.634	0.289	-----	
Nacelle position A-1-B, faired into wing											
S. N.	Exposed cylinders.....	0.198	0.378	0.531	0.650	0.724	0.749	0.731	0.639	0.361	-----
	N. A. C. A. hood.....	.192	.361	.504	.612	.684	.730	.741	.716	.585	-----
	Ring 3, position 2.....	.191	.361	.504	.624	.710	.755	.761	.725	.601	-----
	Variable ring -8°.....	.189	.354	.487	.587	.655	.695	.708	.683	.565	-----
	N. A. C. A. cowling.....	.183	.349	.492	.601	.677	.715	.713	.651	.464	-----
Nacelle position A-1-B, unfaired											
S. N.	Exposed cylinders.....	0.188	0.358	0.501	0.616	0.700	0.749	0.757	0.714	0.545	-----
	N. A. C. A. hood.....	.185	.336	.482	.600	.680	.721	.733	.700	.525	-----
	Ring 3, position 2.....	.190	.360	.502	.612	.685	.727	.748	.718	.589	-----
Nacelle position A-2-B											
S. N.	Exposed cylinders.....	0.204	0.391	0.549	0.680	0.783	0.859	0.890	0.878	0.760	-----
	N. A. C. A. hood.....	.200	.384	.538	.659	.732	.771	.769	.797	.433	-----
	Ring 3, position 2.....	.202	.385	.543	.673	.770	.821	.830	.796	.590	-----
	Variable ring -8°.....	.199	.379	.532	.653	.740	.785	.792	.737	.467	-----
	N. A. C. A. cowling.....	.196	.370	.519	.640	.720	.770	.765	.700	.360	-----

TABLE VI.—PROPULSIVE EFFICIENCY—Continued

$$\eta = \frac{(T - \Delta D) V}{P}$$

Propeller No. 4412-4 feet. Set 17° at 0.75 R. Angle of attack = +5°

Type of nacelle		$\frac{V}{nD}$									
		0.1	0.2	0.3	0.4	0.5	0.6	0.7	0.8	0.9	1.0
Nacelle position B, side brackets removed											
Small nacelle	Exposed cylinders.....	0.188	0.351	0.488	0.596	0.666	0.708	0.702	0.638	0.359	-----
	N. A. C. A. hood.....	.187	.352	.488	.593	.663	.714	.706	.633	.262	-----
	Ring 3, position 2.....	.183	.347	.487	.599	.673	.715	.716	.656	.410	-----
	Ring 3, position 3.....	.186	.347	.481	.586	.663	.708	.727	.676	.430	-----
	Ring 1, position 2.....	.185	.354	.496	.609	.696	.759	.770	.736	.563	-----
	Ring 1, position 3.....	.191	.359	.502	.611	.695	.756	.762	.720	.560	-----
	Variable ring -8°.....	.191	.359	.496	.605	.682	.724	.730	.665	.403	-----
N. A. C. A. cowling.....	.192	.363	.504	.611	.684	.706	.695	.605	.240	-----	
Nacelle position B, with side brackets											
S. N.	Exposed cylinders.....	0.187	0.350	0.485	0.586	0.655	0.683	0.671	0.605	0.322	-----
	N. A. C. A. hood.....	.186	.350	.489	.600	.675	.715	.715	.650	.328	-----
	Ring 3, position 2.....	.187	.351	.488	.590	.672	.725	.748	.706	.463	-----
Nacelle position B-1-A, Faired into wing											
S. N.	Exposed cylinders.....	0.190	0.348	0.476	0.572	0.645	0.690	0.706	0.659	0.450	-----
	N. A. C. A. hood.....	.185	.345	.477	.578	.644	.679	.668	.571	.239	-----
	Ring 3, position 2.....	.187	.352	.489	.586	.668	.700	.700	.642	.402	-----
	Variable ring -8°.....	.185	.349	.485	.592	.665	.714	.718	.666	.433	-----
	N. A. C. A. cowling.....	.189	.357	.496	.593	.652	.682	.665	.557	.159	-----
Nacelle position B-1-A, unfaired											
N. A. C. A. cowling.....	0.190	0.357	0.489	0.589	0.652	0.680	0.673	0.590	0.246	-----	
Nacelle position A-1-B, faired into wing											
S. N.	Exposed cylinders.....	0.193	0.363	0.505	0.615	0.693	0.744	0.778	0.781	0.754	-----
	N. A. C. A. hood.....	.186	.349	.484	.586	.650	.672	.660	.610	.460	-----
	Ring 3, position 2.....	.189	.355	.496	.608	.686	.730	.736	.705	.609	-----
	Variable ring -8°.....	.188	.353	.489	.594	.665	.699	.695	.646	.501	-----
	N. A. C. A. Cowling.....	.185	.352	.496	.607	.666	.693	.700	.651	.532	-----
Nacelle position A-1-B, unfaired											
S. N.	Exposed cylinders.....	0.184	0.347	0.481	0.586	0.659	0.709	0.716	0.672	0.540	-----
	N. A. C. A. hood.....	.182	.341	.468	.566	.633	.668	.668	.620	.485	-----
	Ring 3, position 2.....	.187	.353	.489	.584	.646	.691	.716	.710	.619	-----
Nacelle position A-2-B											
S. N.	Exposed cylinders.....	0.204	0.390	0.546	0.661	0.749	0.810	0.840	0.836	0.743	-----
	N. A. C. A. hood.....	.196	.371	.518	.635	.716	.769	.786	.757	.617	-----
	Ring 3, position 2.....	.198	.372	.518	.636	.722	.778	.808	.800	.721	-----
	Variable ring -8°.....	.196	.371	.522	.642	.734	.787	.805	.797	.727	-----
	N. A. C. A. cowling.....	.195	.367	.514	.629	.714	.760	.767	.731	.570	-----

TABLE VI.—PROPULSIVE EFFICIENCY—Continued

$$\eta = \frac{(T - \Delta D)V}{P}$$

Propeller No. 4412—4 feet. Set 17° at 0.75 R. Angle of attack = +10°

Type of nacelle		$\frac{V}{nD}$									
		0.1	0.2	0.3	0.4	0.5	0.6	0.7	0.8	0.9	1.0
Nacelle position B, side brackets removed											
Small nacelle	Exposed cylinders.....	0.180	0.329	0.444	0.523	0.575	0.595	0.575	0.490	0.203	-----
	N. A. C. A. hood.....	.181	.334	.457	.547	.605	.634	.635	.593	.346	-----
	Ring 3, position 2.....	.179	.332	.454	.547	.604	.627	.618	.550	.325	-----
	Ring 3, position 3.....	.180	.330	.449	.534	.594	.620	.615	.566	.376	-----
	Ring 1, position 2.....	.176	.336	.467	.569	.636	.670	.670	.617	.434	-----
	Ring 1, position 3.....	.185	.339	.461	.550	.615	.653	.670	.658	.552	-----
	Variable ring -8°.....	.183	.335	.457	.545	.603	.636	.641	.592	.426	-----
N. A. C. A. cowling.....	.186	.349	.474	.565	.617	.637	.640	.560	.281	-----	
Nacelle position B, with side brackets											
S. N.	Exposed cylinders.....	0.181	0.332	0.455	0.548	0.609	0.644	0.646	0.603	0.450	-----
	N. A. C. A. hood.....	.180	.332	.453	.543	.598	.620	.611	.525	.202	-----
	Ring 3, position 2.....	.184	.345	.471	.565	.615	.630	.615	.529	.265	-----
Nacelle position B-1-A, faired into wing											
S. N.	Exposed cylinders.....	0.187	0.341	0.460	0.542	0.585	0.593	0.555	0.448	0.120	-----
	N. A. C. A. hood.....	.180	.333	.454	.546	.600	.615	.588	.468	.060	-----
	Ring 3, position 2.....	.182	.335	.457	.544	.595	.612	.594	.507	.217	-----
	Variable ring -8°.....	.180	.336	.462	.557	.619	.648	.635	.550	.244	-----
	N. A. C. A. cowling.....	.181	.336	.455	.537	.578	.590	.564	.430	-----	-----
Nacelle position B-1-A, unfaired											
N. A. C. A. cowling.....	0.182	0.340	0.466	0.557	0.611	0.627	0.589	0.451	-----	-----	
Nacelle position A-1-B, faired into wing											
S. N.	Exposed cylinders.....	0.188	0.351	0.478	0.571	0.627	0.652	0.647	0.617	0.534	-----
	N. A. C. A. hood.....	.182	.334	.454	.539	.586	.606	.596	.564	.460	-----
	Ring 3, position 2.....	.183	.337	.460	.552	.612	.650	.654	.626	.544	-----
	Variable ring -8°.....	.185	.341	.466	.560	.625	.655	.650	.609	.483	-----
	N. A. C. A. cowling.....	-----	-----	-----	-----	-----	-----	-----	-----	-----	-----
Nacelle position A-1-B, unfaired											
S. N.	Exposed cylinders.....	0.179	0.335	0.463	0.558	0.612	0.627	0.603	0.527	0.342	-----
	N. A. C. A. hood.....	.182	.338	.461	.555	.615	.638	.615	.566	.420	-----
	Ring 3, position 2.....	.179	.331	.452	.539	.597	.621	.621	.590	.520	-----
Nacelle position A-2-B											
S. N.	Exposed cylinders.....	0.204	0.386	0.534	0.640	0.702	0.730	0.725	0.681	0.532	-----
	N. A. C. A. hood.....	.190	.360	.501	.610	.676	.711	.719	.688	.577	-----
	Ring 3, position 2.....	.196	.366	.508	.618	.697	.739	.750	.735	.656	-----
	Variable ring -8°.....	.195	.357	.495	.607	.684	.731	.748	.727	.665	-----
	N. A. C. A. cowling.....	.191	.354	.487	.589	.660	.709	.725	.716	.650	-----

TABLE VII.—LIFT COEFFICIENT WITH PROPELLER OPERATING

$$C_{LP} = \frac{L_P}{qS}$$

Propeller No. 4412—4 feet. Set 17° at 0.75 R. Angle of attack = -5°

Type of nacelle		$\frac{V}{nD}$									
		0.1	0.2	0.3	0.4	0.5	0.6	0.7	0.8	0.9	1.0
Nacelle position B, side brackets removed											
Small nacelle	Exposed cylinders.....				0.197	0.174	0.161	0.155	0.156	0.160	0.169
	N. A. C. A. hood.....				.177	.163	.157	.152	.150	.150	.151
	Ring 3, position 2.....				.182	.170	.160	.155	.151	.150	.150
	Ring 3, position 3.....				.216	.177	.157	.150	.151	.152	.155
	Ring 1, position 2.....				.210	.173	.155	.148	.149	.152	.157
	Ring 1, position 3.....				.195	.171	.159	.154	.155	.156	.158
	Variable ring -8°.....				.153	.160	.162	.164	.163	.161	.160
N. A. C. A. cowling.....				.188	.181	.175	.168	.157	.145	.132	
Nacelle position B, with side brackets											
S. N.	Exposed cylinders.....				0.183	0.169	0.160	0.153	0.152	0.150	0.151
	N. A. C. A. hood.....				.167	.160	.154	.153	.153	.157	.160
	Ring 3, position 2.....				.173	.166	.162	.161	.161	.161	.162
Nacelle position B-1-A, faired into wing											
S. N.	Exposed cylinders.....				0.190	0.178	0.169	0.160	0.155	0.152	0.153
	N. A. C. A. hood.....				.205	.190	.180	.172	.169	.165	.165
	Ring 3, position 2.....										
	Variable ring -8°.....				.192	.184	.178	.170	.161	.153	.147
	N. A. C. A. cowling.....				.223	.210	.200	.190	.184	.179	.174
Nacelle position B-1-A, unfaired											
	N. A. C. A. cowling.....				0.255	0.208	0.180	0.163	0.155	0.155	0.160
Nacelle position A-1-B, faired into wing											
N. N.	Exposed cylinders.....				0.127	0.142	0.152	0.161	0.169	0.174	0.177
	N. A. C. A. hood.....				.135	.134	.137	.140	.147	.155	.164
	Ring 3, position 2.....				.124	.140	.150	.156	.159	.159	.157
	Variable ring -8°.....				.131	.141	.150	.157	.160	.163	.167
	N. A. C. A. cowling.....				.170	.146	.133	.127	.127	.131	.139
Nacelle position A-1-B, unfaired											
S. N.	Exposed cylinders.....				0.145	0.161	0.173	0.184	0.191	0.197	0.202
	N. A. C. A. hood.....				.127	.141	.150	.158	.160	.160	.160
	Ring 3, position 2.....				.128	.141	.148	.151	.156	.160	.163
Nacelle position A-2-B											
N. N.	Exposed cylinders.....				0.118	0.120	0.121	0.125	0.131	0.139	0.148
	N. A. C. A. hood.....				.114	.114	.114	.117	.121	.128	.136
	Ring 3, position 2.....										
	Variable ring -8°.....				.100	.113	.122	.127	.129	.127	.123
	N. A. C. A. cowling.....				.122	.113	.110	.113	.120	.129	.142

TABLE VII.—LIFT COEFFICIENT WITH PROPELLER OPERATING—Continued

$$C_{LP} = \frac{L_P}{vS}$$

Propeller No. 4412—4 feet. Set 17° at 0.75 R. Angle of attack=0°

Type of nacelle		$\frac{V}{nD}$									
		0.1	0.2	0.3	0.4	0.5	0.6	0.7	0.8	0.9	1.0
Nacelle position B, side brackets removed											
Small nacelle	Exposed cylinders.....				0.459	0.433	0.414	0.403	0.393	0.390	0.390
	N. A. C. A. hood.....				.457	.421	.405	.397	.390	.388	.385
	Ring 3, position 2.....				.449	.426	.410	.397	.388	.382	.377
	Ring 3, position 3.....				.461	.426	.403	.388	.380	.379	.380
	Ring 1, position 2.....				.455	.431	.414	.403	.397	.393	.391
	Ring 1, position 3.....				.463	.425	.399	.388	.386	.387	.389
	Variable ring, -8°.....				.475	.433	.407	.392	.388	.389	.393
N. A. C. A. cowling.....				.451	.432	.418	.406	.397	.392	.390	
Nacelle position B, with side brackets											
S. N.	Exposed cylinders.....				0.477	0.437	0.412	0.400	0.396	0.397	0.398
	N. A. C. A. hood.....				.453	.428	.410	.397	.389	.383	.381
	Ring 3, position 2.....				.447	.423	.407	.396	.388	.381	.376
Nacelle position B-1-A, faired into wing											
S. N.	Exposed cylinders.....				0.478	0.438	0.415	0.404	0.400	0.398	0.398
	N. A. C. A. hood.....				.475	.447	.427	.412	.402	.396	.390
	Ring 3, position 2.....				.482	.439	.417	.407	.400	.393	.388
	Variable wing, -8°.....				.459	.431	.413	.400	.397	.397	.390
	N. A. C. A. cowling.....				.456	.438	.424	.416	.410	.408	.404
Nacelle position B-1-A, unfaired											
N. A. C. A. cowling.....				0.470	0.433	0.411	0.398	0.391	0.390	0.390	
Nacelle position A-1-B, faired into wing											
S. N.	Exposed cylinders.....				0.397	0.397	0.397	0.398	0.398	0.398	0.398
	N. A. C. A. hood.....				.366	.375	.380	.384	.389	.392	.397
	Ring 3, position 2.....				.389	.386	.385	.385	.387	.389	.390
	Variable ring, -8°.....				.392	.383	.380	.380	.381	.384	.390
	N. A. C. A. cowling.....				.395	.388	.384	.382	.380	.381	.383
Nacelle position A-1-B, unfaired											
S. N.	Exposed cylinders.....				0.383	0.394	0.401	0.407	0.410	0.411	0.410
	N. A. C. A. hood.....				.383	.387	.390	.393	.397	.400	.402
	Ring 3, position 2.....				.389	.395	.397	.398	.398	.398	.398
Nacelle position A-2-B											
S. N.	Exposed cylinders.....				0.352	0.353	0.355	0.360	0.363	0.370	.376
	N. A. C. A. hood.....				.363	.360	.358	.358	.360	.363	.368
	Ring 3, position 2.....				.357	.361	.366	.370	.373	.378	.380
	Variable ring -8°.....				.349	.350	.352	.355	.359	.360	.361
	N. A. C. A. cowling.....				.354	.356	.358	.360	.361	.363	.364

TABLE VII.—LIFT COEFFICIENT WITH PROPELLER OPERATING—Continued

$$C_{LP} = \frac{L_P}{qS}$$

Propeller No. 4412—4 feet. Set 17° at 0.75 R. Angle of attack = +5°

Type of nacelle		$\frac{V}{nD}$									
		0.1	0.2	0.3	0.4	0.5	0.6	0.7	0.8	0.9	1.0
Nacelle position B, side brackets removed											
Small nacelle	Exposed cylinders.....				0.728	0.695	0.672	0.654	0.643	0.636	0.631
	N. A. C. A. hood.....				.765	.705	.670	.652	.641	.632	.628
	Ring 3, position 2.....				.752	.702	.668	.646	.631	.624	.620
	Ring 3, position 3.....				.725	.688	.660	.640	.628	.619	.613
	Ring 1, position 2.....				.718	.691	.670	.655	.643	.633	.622
	Ring 1, position 3.....				.745	.698	.667	.650	.638	.630	.623
	Variable ring -8°.....				.735	.692	.662	.640	.622	.612	.606
N. A. C. A. cowling.....				.735	.709	.688	.672	.660	.648	.639	
Nacelle position B, with side brackets											
S. N.	Exposed cylinders.....				0.750	0.704	0.667	0.640	0.623	0.607	0.597
	N. A. C. A. hood.....				.749	.712	.683	.663	.648	.636	.627
	Ring 3, position 2.....				.727	.689	.667	.652	.640	.631	.627
Nacelle position B-1-A, faired into wing											
S. N.	Exposed cylinders.....				0.758	0.706	0.670	0.645	0.630	0.618	0.610
	N. A. C. A. hood.....				.760	.712	.675	.652	.639	.631	.630
	Ring 3, position 2.....				.775	.705	.670	.652	.649	.640	.629
	Variable ring -8°.....				.733	.701	.677	.658	.644	.633	.625
	N. A. C. A. cowling.....				.746	.719	.700	.685	.673	.665	.658
Nacelle position B-1-A, unfaired											
	N. A. C. A. cowling.....				0.755	0.703	0.663	0.637	0.620	0.609	0.601
Nacelle position A-1-B, faired into wing											
S. N.	Exposed cylinders.....				0.665	0.653	0.644	0.639	0.632	0.628	0.623
	N. A. C. A. hood.....				.680	.668	.658	.648	.640	.637	.632
	Ring 3, position 2.....				.673	.661	.650	.641	.636	.631	.629
	Variable ring -8°.....				.675	.660	.648	.639	.630	.624	.620
	N. A. C. A. cowling.....				.667	.651	.639	.631	.625	.621	.621
Nacelle position A-1-B, unfaired											
S. N.	Exposed cylinders.....				0.691	0.668	0.652	0.642	0.638	0.635	0.633
	N. A. C. A. hood.....				.663	.656	.650	.644	.640	.639	.638
	Ring 3, position 2.....				.678	.660	.651	.645	.638	.634	.629
Nacelle position A-2-B											
S. N.	Exposed cylinders.....				0.606	0.608	0.610	0.612	0.616	0.618	0.620
	N. A. C. A. hood.....				.638	.625	.619	.616	.615	.617	.619
	Ring 3, position 2.....				.609	.613	.618	.620	.621	.621	.620
	Variable ring -8°.....				.621	.620	.620	.620	.619	.618	.617
	N. A. C. A. cowling.....				.618	.616	.614	.614	.614	.614	.614

TABLE VII.—LIFT COEFFICIENT WITH PROPELLER OPERATING—Continued

$$C_{LP} = \frac{L_P}{qS}$$

Propeller No. 4412—4 feet. Set 17° at 0.75 R. Angle of attack = +10°

Type of nacelle		$\frac{V}{nD}$									
		0.1	0.2	0.3	0.4	0.5	0.6	0.7	0.8	0.9	1.0
Nacelle position B, side brackets removed											
Small nacelle	Exposed cylinders.....				1.033	0.981	0.941	0.912	0.890	0.874	0.861
	N. A. C. A. hood.....				1.075	.985	.936	.912	.902	.897	.891
	Ring 3, position 2.....				1.023	.978	.943	.918	.900	.887	.878
	Ring 3, position 3.....				1.027	.975	.938	.912	.894	.882	.873
	Ring 1, position 2.....				1.035	.978	.943	.918	.900	.888	.880
	Ring 1, position 3.....				1.030	.970	.932	.907	.890	.880	.870
	Variable ring -8°.....				.990	.950	.921	.898	.882	.869	.860
	N. A. C. A. cowling.....				1.026	.983	.952	.930	.916	.905	.899
Nacelle position B, with side brackets											
S. N.	Exposed cylinders.....				1.030	0.950	0.887	0.839	0.807	0.782	0.764
	N. A. C. A. hood.....				1.035	.981	.944	.919	.901	.891	.888
	Ring 3, position 2.....				1.020	.967	.935	.915	.900	.887	.877
Nacelle position B-1-A, faired into wing											
S. N.	Exposed cylinders.....				1.022	0.964	0.919	0.888	0.863	0.847	0.835
	N. A. C. A. hood.....				1.045	.982	.941	.918	.900	.889	.883
	Ring 3, position 2.....				1.032	.976	.936	.910	.892	.880	.870
	Variable ring -8°.....				1.020	.970	.937	.916	.900	.890	.880
	N. A. C. A. cowling.....				1.032	.990	.959	.935	.917	.902	.893
Nacelle position B-1-A, unfaired											
N. A. C. A. cowling.....				1.040	0.953	0.898	0.861	0.837	0.821	0.811	
Nacelle position A-1-B, faired into wing											
S. N.	Exposed cylinders.....				0.971	0.940	0.918	0.902	0.890	0.883	0.879
	N. A. C. A. hood.....				.960	.935	.918	.903	.891	.881	.871
	Ring 3, position 2.....				.961	.933	.913	.898	.887	.878	.870
	Variable ring -8°.....				.990	.945	.913	.890	.875	.865	.860
	N. A. C. A. cowling.....				.975	.942	.918	.901	.890	.880	.872
Nacelle position A-1-B, unfaired											
S. N.	Exposed cylinders.....				0.958	0.935	0.919	0.907	0.898	0.890	0.883
	N. A. C. A. hood.....				.973	.940	.916	.897	.885	.877	.870
	Ring 3, position 2.....				.990	.946	.916	.900	.890	.883	.879
Nacelle position A-2-B											
S. N.	Exposed cylinders.....				0.912	0.893	0.881	0.875	0.872	0.872	0.873
	N. A. C. A. hood.....				.919	.906	.896	.888	.880	.875	.872
	Ring 3, position 2.....				.881	.882	.882	.881	.877	.871	.865
	Variable ring -8°.....				.920	.900	.886	.878	.872	.870	.869
	N. A. C. A. cowling.....				.877	.873	.871	.868	.865	.863	.860

TABLE VIII—Continued
MOMENT COEFFICIENT WITH PROPELLER OPERATING—Continued

$$C_{mP} = \frac{M_P}{qSc}$$

Propeller No. 4412—4 feet. Set 17° at 0.75 R. Angle of attack=0°

Type of nacelle		$\frac{V}{nD}$									
		0.1	0.2	0.3	0.4	0.5	0.6	0.7	0.8	0.9	1.0
Nacelle position B, side brackets removed											
Small nacelle	Exposed cylinders.....				-0.097	-0.084	-0.075	-0.070	-0.068	-0.065	-0.064
	N. A. C. A. Hood.....				-.097	-.084	-.075	-.070	-.066	-.065	-.064
	Ring 3, position 2.....				-.100	-.083	-.073	-.068	-.065	-.063	-.061
	Ring 3, position 3.....				-.093	-.081	-.074	-.070	-.067	-.065	-.064
	Ring 1, position 2.....				-.092	-.080	-.073	-.070	-.068	-.066	-.065
	Ring 1, position 3.....				-.095	-.082	-.074	-.070	-.067	-.064	-.062
	Variable ring -8°.....				-.095	-.080	-.071	-.067	-.064	-.062	-.060
N. A. C. A. Cowling.....				-.085	-.077	-.072	-.069	-.065	-.065	-.063	
Nacelle position B, with side brackets											
S. N.	Exposed cylinders.....				-0.096	-0.084	-0.075	-0.070	-0.065	-0.063	-0.061
	N. A. C. A. Hood.....				-.096	-.084	-.076	-.070	-.066	-.065	-.064
	Ring 3, position 2.....				-.095	-.083	-.075	-.068	-.065	-.062	-.061
Nacelle position B-1-A, faired into wing											
N. S.	Exposed cylinders.....				-0.112	-0.091	-0.076	-0.065	-0.057	-0.052	-0.049
	N. A. C. A. Hood.....				-.117	-.089	-.073	-.061	-.055	-.050	-.045
	Ring 3, position 2.....				-.114	-.089	-.072	-.061	-.054	-.050	-.050
	Variable ring -8°.....				-.120	-.091	-.072	-.061	-.053	-.050	-.050
	N. A. C. A. Cowling.....				-.080	-.062	-.051	-.045	-.040	-.035	-.030
Nacelle position B-1-A, unfaired											
N. A. C. A. Cowling.....				-0.100	-0.080	-0.067	-0.058	-0.053	-0.049	-0.046	
Nacelle position A-1-B, faired into wing											
N. S.	Exposed cylinders.....				-0.055	-0.063	-0.063	-0.070	-0.072	-0.073	-0.073
	N. A. C. A. Hood.....				-.058	-.068	-.075	-.077	-.078	-.079	-.080
	Ring 3, position 2.....				-.075	-.077	-.078	-.080	-.080	-.081	-.082
	Variable ring -8°.....				-.063	-.069	-.074	-.077	-.080	-.081	-.082
	N. A. C. A. Cowling.....				-.070	-.073	-.076	-.078	-.080	-.080	-.080
Nacelle position A-1-B, unfaired											
S. N.	Exposed cylinders.....				-0.050	-0.058	-0.065	-0.074	-0.073	-0.075	-0.075
	N. A. C. A. Hood.....				-.054	-.063	-.070	-.072	-.074	-.073	-.072
	Ring 3, position 2.....				-.047	-.064	-.072	-.075	-.077	-.079	-.079
Nacelle position A-2-B											
N. S.	Exposed cylinders.....				-0.023	-0.040	-0.054	-0.063	-0.070	-0.075	-0.076
	N. A. C. A. Hood.....				-.021	-.039	-.053	-.062	-.068	-.072	-.075
	Ring 3, position 2.....				-.017	-.040	-.056	-.066	-.070	-.074	-.075
	Variable ring -8°.....				-.011	-.042	-.057	-.065	-.070	-.074	-.076
	N. A. C. A. Cowling.....				-.030	-.045	-.057	-.065	-.071	-.075	-.078

TABLE VIII—Continued
MOMENT COEFFICIENT WITH PROPELLER OPERATING—Continued

$$C_{mP} = \frac{M_P}{qSc}$$

Propeller No. 4412—4 feet. Set 17° at 0.75 R. Angle of attack = +5°

Type of nacelle		$\frac{V}{nD}$									
		0.1	0.2	0.3	0.4	0.5	0.6	0.7	0.8	0.9	1.0
Nacelle position B, side brackets removed											
Small nacelle	Exposed cylinders				-0.092	-0.077	-0.067	-0.062	-0.059	-0.057	-0.055
	N. A. C. A. hood				-0.100	-0.073	-0.063	-0.059	-0.056	-0.054	-0.054
	Ring 3, position 2				-0.092	-0.073	-0.063	-0.058	-0.055	-0.054	-0.052
	Ring 3, position 3				-0.085	-0.072	-0.063	-0.057	-0.055	-0.051	-0.050
	Ring 1, position 2				-0.082	-0.072	-0.065	-0.060	-0.058	-0.056	-0.055
	Ring 1, position 3				-0.105	-0.080	-0.066	-0.060	-0.056	-0.053	-0.051
	Variable ring -8°				-0.094	-0.073	-0.062	-0.057	-0.055	-0.053	-0.052
N. A. C. A. cowling				-0.071	-0.066	-0.062	-0.060	-0.057	-0.055	-0.055	
Nacelle position B, with side brackets											
S. N.	Exposed cylinders				-0.083	-0.070	-0.062	-0.056	-0.054	-0.052	-0.050
	N. A. C. A. hood				-0.083	-0.071	-0.065	-0.060	-0.056	-0.053	-0.051
	Ring 3, position 2				-0.083	-0.068	-0.060	-0.057	-0.055	-0.052	-0.050
Nacelle position B-1-A, faired into wing											
S. N.	Exposed cylinders				-0.118	-0.088	-0.070	-0.060	-0.054	-0.050	-0.049
	N. A. C. A. hood				-0.109	-0.081	-0.065	-0.055	-0.049	-0.045	-0.041
	Ring 3, position 2				-0.100	-0.078	-0.062	-0.052	-0.045	-0.040	-0.038
	Variable ring -8°				-0.115	-0.084	-0.065	-0.054	-0.047	-0.045	-0.045
	N. A. C. A. cowling				-0.098	-0.077	-0.061	-0.050	-0.043	-0.038	-0.036
Nacelle position B-1-A, unfaired											
N. A. C. A. cowling				-0.091	-0.076	-0.065	-0.057	-0.050	-0.047	-0.045	
Nacelle position A-1-B, faired into wing											
S. N.	Exposed cylinders				-0.057	-0.064	-0.068	-0.070	-0.073	-0.075	-0.075
	N. A. C. A. hood				-0.057	-0.066	-0.072	-0.075	-0.075	-0.075	-0.076
	Ring 3, position 2				-0.070	-0.073	-0.075	-0.075	-0.075	-0.075	-0.074
	Variable ring -8°				-0.064	-0.070	-0.074	-0.076	-0.078	-0.079	-0.078
	N. A. C. A. cowling				-0.066	-0.070	-0.072	-0.075	-0.075	-0.075	-0.074
Nacelle position A-1-B, unfaired											
S. N.	Exposed cylinders				-0.058	-0.062	-0.065	-0.069	-0.070	-0.072	-0.072
	N. A. C. A. hood				-0.060	-0.065	-0.067	-0.070	-0.070	-0.070	-0.071
	Ring 3, position 2				-0.064	-0.069	-0.072	-0.075	-0.075	-0.075	-0.075
Nacelle position A-2-B											
S. N.	Exposed cylinders				-0.021	-0.040	-0.055	-0.065	-0.070	-0.074	-0.075
	N. A. C. A. hood				-0.017	-0.038	-0.053	-0.062	-0.068	-0.070	-0.072
	Ring 3, position 2				-0.006	-0.037	-0.055	-0.063	-0.067	-0.070	-0.073
	Variable ring -8°				-0.004	-0.040	-0.057	-0.064	-0.068	-0.071	-0.073
	N. A. C. A. cowling				-0.012	-0.042	-0.057	-0.062	-0.065	-0.068	-0.068

TABLE VIII—Continued

MOMENT COEFFICIENT WITH PROPELLER OPERATING—Continued

$$C_{mP} = \frac{M_P}{qSc}$$

Propeller No. 4412—4 feet. Set 17° at 0.75 R. Angle of attack = +10°

[Type of nacelle]		$\frac{V}{nD}$									
		0.1	0.2	0.3	0.4	0.5	0.6	0.7	0.8	0.9	1.0
Nacelle position B, side brackets removed											
Small nacelle	Exposed cylinders.....				-0.092	-0.077	-0.067	-0.060	-0.056	-0.054	-0.053
	N. A. C. A. hood.....				-0.109	-0.071	-0.060	-0.057	-0.055	-0.054	-0.054
	Ring 3, position 2.....				-0.086	-0.067	-0.057	-0.052	-0.050	-0.050	-0.050
	Ring 3, position 3.....				-0.069	-0.063	-0.058	-0.055	-0.052	-0.051	-0.050
	Ring 1, position 2.....				-0.075	-0.065	-0.060	-0.055	-0.055	-0.054	-0.053
	Ring 1, position 3.....				-0.078	-0.067	-0.059	-0.055	-0.051	-0.050	-0.051
	Variable ring -8°.....				-0.081	-0.066	-0.057	-0.051	-0.049	-0.048	-0.046
N. A. C. A. cowling.....				-0.074	-0.065	-0.059	-0.055	-0.052	-0.051	-0.050	
Nacelle position B, with side brackets											
S. N.	Exposed cylinders.....				-0.072	-0.065	-0.060	-0.057	-0.055	-0.054	-0.053
	N. A. C. A. hood.....				-0.083	-0.063	-0.056	-0.054	-0.052	-0.051	-0.050
	Ring 3, position 2.....				-0.073	-0.060	-0.053	-0.050	-0.048	-0.047	-0.046
Nacelle position B-1-A, faired into wing											
S. N.	Exposed cylinders.....				-0.103	-0.080	-0.065	-0.055	-0.048	-0.045	-0.043
	N. A. C. A. hood.....				-0.113	-0.079	-0.061	-0.050	-0.044	-0.041	-0.042
	Ring 3, position 2.....				-0.112	-0.076	-0.058	-0.049	-0.044	-0.042	-0.043
	Variable ring -8°.....				-0.089	-0.070	-0.058	-0.049	-0.043	-0.040	-0.039
	N. A. C. A. cowling.....				-0.093	-0.074	-0.060	-0.051	-0.045	-0.042	-0.042
Nacelle position B-1-A, unfaired											
N. A. C. A. cowling.....				-0.085	-0.073	-0.065	-0.060	-0.055	-0.053	-0.052	
Nacelle position A-1-B, faired into wing											
S. N.	Exposed cylinders.....				-0.057	-0.065	-0.070	-0.073	-0.075	-0.075	-0.074
	N. A. C. A. hood.....				-0.050	-0.063	-0.070	-0.072	-0.074	-0.074	-0.074
	Ring 3, position 2.....				-0.072	-0.074	-0.075	-0.075	-0.075	-0.075	-0.075
	Variable ring -8°.....				-0.077	-0.080	-0.080	-0.080	-0.081	-0.083	-0.084
	N. A. C. A. cowling.....				-0.069	-0.071	-0.074	-0.075	-0.075	-0.075	-0.075
Nacelle position A-1-B, unfaired											
S. N.	Exposed cylinders.....				-0.062	-0.065	-0.069	-0.070	-0.072	-0.074	-0.074
	N. A. C. A. hood.....				-0.060	-0.065	-0.067	-0.070	-0.070	-0.070	-0.071
	Ring 3, position 2.....				-0.065	-0.070	-0.072	-0.074	-0.074	-0.074	-0.074
Nacelle position A-2-B											
S. N.	Exposed cylinders.....				-0.020	-0.040	-0.055	-0.065	-0.070	-0.074	-0.075
	N. A. C. A. hood.....				-0.018	-0.038	-0.051	-0.061	-0.067	-0.070	-0.073
	Ring 3, position 2.....				-0.011	-0.038	-0.055	-0.064	-0.068	-0.070	-0.073
	Variable ring -8°.....				-0.020	-0.041	-0.055	-0.062	-0.067	-0.071	-0.075
	N. A. C. A. cowling.....				-0.008	-0.040	-0.057	-0.063	-0.066	-0.070	-0.070

TABLE IX
RELATIVE MERITS OF VARIOUS COWLINGS FOR DIFFERENT NACELLE LOCATIONS
HIGH AND CRUISING SPEED CONDITION

Propeller No. 4412-4 feet. Set 17° at 0.75 R. $\frac{V}{nD}=0.65$ $C_L=0.409$

Nacelle location		B ¹	B	B-1-A ²	B-1-A	A-1-B ²	A-1-B	A-2-B
Propulsive efficiency (η)								
Small nacelle	Exposed cylinders	0.778	0.770	0.780	-----	0.750	0.755	0.871
	N. A. C. A. hood750	.767	.754	-----	.736	.730	.781
	Ring 3, position 2806	.794	.804	-----	.760	.743	.822
	Ring 3, position 3794	-----	-----	-----	-----	-----	-----
	Ring 1, position 2845	-----	-----	-----	-----	-----	-----
	Ring 1, position 3848	-----	-----	-----	-----	-----	-----
	Variable ring -8°788	-----	.783	-----	.708	-----	.798
	N. A. C. A. cowling761	-----	.732	0.719	.719	-----	.770
Nacelle drag efficiency factor (N. D. F.)								
Small nacelle	Exposed cylinders	0.1750	0.2060	0.2555	-----	0.2925	0.2930	0.3945
	N. A. C. A. hood0775	.1050	.1183	-----	.2055	.2535	.2605
	Ring 3, position 21740	.1670	.1970	-----	.2422	.2787	.2615
	Ring 3, position 31725	-----	-----	-----	-----	-----	-----
	Ring 1, position 22615	-----	-----	-----	-----	-----	-----
	Ring 1, position 33085	-----	-----	-----	-----	-----	-----
	Variable Ring -8°1210	-----	.1785	-----	.2095	-----	.2675
	N. A. C. A. cowling0095	-----	.0724	0.2801	.0792	-----	.1612
Net efficiency (η -N. D. F.)								
Small nacelle	Exposed cylinders	0.603	0.564	0.525	-----	0.458	0.462	0.477
	N. A. C. A. hood673	.662	.636	-----	.531	.477	.521
	Ring 3, position 2632	.627	.607	-----	.518	.464	.561
	Ring 3, position 3622	-----	-----	-----	-----	-----	-----
	Ring 1, position 2584	-----	-----	-----	-----	-----	-----
	Ring 1, position 3540	-----	-----	-----	-----	-----	-----
	Variable ring -8°667	-----	.605	-----	.499	-----	.531
	N. A. C. A. cowling752	-----	.660	0.439	.640	-----	.609

¹ Side brackets removed.

² Faired into wing.

TABLE X
RELATIVE MERITS OF VARIOUS COWLINGS FOR DIFFERENT NACELLE LOCATIONS
CLIMBING CONDITION

Propeller No. 4412, 4 feet. Set 17° at 0.75 R. $\frac{V}{nD}=0.42$ $C_L=0.652$

Nacelle location		B ¹	B	B-1-A ²	B-1-A	A-1-B ²	A-1-B	A-2-B
Propulsive efficiency (η)								
Small nacelle	Exp. cylinders	0.622	0.623	0.605	-----	0.633	0.608	0.678
	N. A. C. A. hood624	.630	.607	-----	.605	.582	.650
	Ring 3, position 2633	.624	.633	-----	.627	.603	.650
	Ring 3, position 3618	-----	-----	-----	-----	-----	-----
	Ring 1, position 2640	-----	-----	-----	-----	-----	-----
	Ring 1, position 3650	-----	-----	-----	-----	-----	-----
	Var. ring -8°640	-----	.620	-----	.608	-----	.660
	N. A. C. A. cowling635	-----	.621	0.611	.618	-----	.647
Nacelle drag efficiency factor (N. D. F.)								
Small nacelle	Exp. Cylinders	-0.126	-0.0314	-0.0082	-----	0.0252	0.0144	0.0708
	N. A. C. A. hood	-.0465	-.0336	-.0326	-----	-.0022	.0165	.0358
	Ring 3, position 2	-.0295	-.0126	-.0268	-----	.0125	.0165	.0598
	Ring 3, position 3	-.0207	-----	-----	-----	-----	-----	-----
	Ring 1, position 2	-.0105	-----	-----	-----	-----	-----	-----
	Ring 1, position 3	-.0041	-----	-----	-----	-----	-----	-----
	Var. ring -8°	-.0378	-----	-.0083	-----	.0020	-----	.0485
	N. A. C. A. cowling	-.0361	-----	-.0127	0.0322	-.0021	-----	.0311
Net efficiency (η -N. D. F.)								
Small nacelle	Exp. cylinders	0.635	0.654	0.612	-----	0.608	0.594	0.607
	N. A. C. A. hood670	.664	.640	-----	.607	.566	.614
	Ring 3, position 2662	.637	.660	-----	.615	.588	.590
	Ring 3, position 3639	-----	-----	-----	-----	-----	-----
	Ring 1, position 2630	-----	-----	-----	-----	-----	-----
	Ring 1, position 3654	-----	-----	-----	-----	-----	-----
	Var. ring -8°678	-----	.628	-----	.606	-----	.612
	N. A. C. A. cowling671	-----	.634	0.579	.620	-----	.616

¹ Side brackets removed

² Faired into wing.