

REPORT 1351

FOREWORD

During the early part of World War II, some of the helicopters designed for military use were observed during ground tests to exhibit a violent oscillatory rotor instability which endangered the safety of the aircraft. This instability was at first attributed to rotor-blade flutter, but a careful analysis indicated it to be caused by a hitherto unknown phenomenon in which the rotational energy of the rotor was converted into oscillatory energy of the blades. This phenomenon was usually critical when the helicopter was operating on or near the ground and, hence, was called ground resonance. An oscillatory instability of such magnitude as resulted from this phenomenon would generate forces that could quickly destroy a helicopter. The research efforts of the National Advisory Committee for Aeronautics were therefore enlisted to investigate the difficulties introduced by this phenomenon. During the interval between 1942 and 1947, a theory of the self-excited instability of hinged rotor blades was worked out by Robert P. Coleman and Arnold M. Feingold at the Langley Aeronautical Laboratory. This theory defined the important parameters and provided design information which made it possible to eliminate this type of instability. These results were originally released by the NACA in three separate papers, as follows:

- (1) NACA Advance Restricted Report 3G29, 1943 (Wartime Report L-308) entitled "Theory of Self-Excited Mechanical Oscillations of Hinged Rotor Blades," by Robert P. Coleman.
- (2) NACA Advance Restricted Report 3I13, 1943 (Wartime Report L-312) entitled "Theory of Mechanical Oscillations of Rotors With Two Hinged Blades," by Arnold M. Feingold.
- (3) NACA Technical Note 1184, 1947, entitled "Theory of Ground Vibrations of a Two-Blade Helicopter Rotor on Anisotropic Flexible Supports," by Robert P. Coleman and Arnold M. Feingold.

These three reports have been recognized to contain the fundamental reference material on the subject of rotor mechanical instability but were for some time out of print. As a result of demands for this type of information, they were combined into a single volume and reissued with appropriate corrections as NACA Technical Note 3844. The combined volume (reissued here as an NACA Report) consists of three chapters representing the three aforementioned papers in consecutive order.

Inasmuch as the authors of these papers are no longer with the NACA, the task of checking these papers and incorporating such corrections as seemed proper was undertaken by George W. Brooks, Vibration and Flutter Branch, Dynamic Loads Division, of the Langley Aeronautical Laboratory. Mr. Brooks also prepared an appendix to chapter III, which deals with the general equations of motion for a two-blade rotor and includes the effects of damping.

CONTENTS

Chapter	Page
I. THEORY OF SELF-EXCITED MECHANICAL OSCILLATIONS OF HINGED ROTOR BLADES,	
by Robert P. Coleman	269
SUMMARY	269
INTRODUCTION	269
SYMBOLS	270
APPROACH TO THE VIBRATION PROBLEM	271
Stability and Instability	271
Choice of Degrees of Freedom	271
Physical Parameters	271
MATHEMATICAL DEVELOPMENTS	272
Method of Analysis	272
Example of Rotor With Locked Hinges	272
Hinged Rotor	273
Deviation of Equations of Motion	274
The Characteristic Equation	276
METHOD OF APPLYING THEORY	277
Application Neglecting Damping	277
Possibility of Avoiding Occurrence of Vibration	278
Effect of Damping	278
LIMITATIONS AND FURTHER DEVELOPMENTS OF THE THEORY	281
Polar Symmetry	281
Two Blades	281
REFERENCES	281
II. THEORY OF MECHANICAL OSCILLATIONS OF ROTORS WITH TWO HINGED BLADES,	
by Arnold M. Feingold	282
SUMMARY	282
INTRODUCTION	282
SYMBOLS	282
MATHEMATICAL ANALYSIS	283
DISCUSSION OF FREQUENCY EQUATION	285
Case of Zero Damping	285
Effect of Damping	286
Brief Description of Vibration Modes	288
CONCLUSIONS	288
REFERENCES	288
III. THEORY OF GROUND VIBRATIONS OF A TWO-BLADE HELICOPTER ROTOR ON ANI-	
SOTROPIC FLEXIBLE SUPPORTS (REVISED), by Robert P. Coleman and Arnold M. Feingold	289
SUMMARY	289
INTRODUCTION	289
DERIVATION OF THE EQUATIONS OF MOTION	289
FORM OF SOLUTION OF EQUATIONS OF MOTION	291
SOLUTION OF EQUATIONS OF MOTION	291
Determinantal Equation	291
Auxiliary Determinants and Recurrence Relations for Calculating $\Delta(\omega_a)$	293
The Behavior of $\Delta_n(\omega_a)$ for Large Values of n	294
Evaluation of Roots of Equation (25)	294
Conditions for Stability	296
SPECIAL CASES OF GENERAL THEORY	296
Case of $K_y = K_z$	296
Case of $K_y = 0$	296
Case of $K_y = \infty$	297
DISCUSSION OF RESULTS	298
Types of Instability	298
General Behavior of Rotor System as a Function of Rotor Speed	298
Comparison of Results for Different Values of K_y/K_z	299
Effect of Damping	300
APPLICATION TO DUAL ROTORS	300
CONCLUSIONS	301
APPENDIX A. SYMBOLS	302
APPENDIX B. THE GENERAL EQUATIONS OF MOTION FOR TWO-BLADE ROTORS,	
by George W. Brooks	303
General Case	303
Special Case—Zero Damping	303
Special Case of Isotropic Supports	303
APPENDIX C. DERIVATION OF THE CONVERGENCE FACTOR FOR $K(0)$	304
APPENDIX D. MATHEMATICAL ANALYSIS FOR THE CASE OF $K_y = \infty$	305
REFERENCES	307

REPORT 1351

THEORY OF SELF-EXCITED MECHANICAL OSCILLATIONS OF HELICOPTER ROTORS WITH HINGED BLADES ¹

By ROBERT P. COLEMAN and ARNOLD M. FEINGOLD

CHAPTER I

THEORY OF SELF-EXCITED MECHANICAL OSCILLATIONS OF HINGED ROTOR BLADES

By ROBERT P. COLEMAN

SUMMARY

Vibrations of rotary-wing aircraft may derive their energy from the rotation of the rotor rather than from the air forces. A theoretical analysis of these vibrations is described and methods for its application are explained herein.

The theory includes the effects of unequal stiffness of the pylon for deflections in different directions and the effect of damping in the hinges and in the pylon. Both the derivation of the characteristics equation and the methods of application of the theory are given. In particular, the theory predicts the so-called "odd frequency" self-excited speed range as well as the shaft critical speed. Charts are presented from which the shaft critical and the self-excited instabilities can be predicted for a great variety of cases. The influence of each physical parameter upon the instabilities has been obtained. The comprehensive treatment applies to a rotor that has any number of blades greater than two. Only a brief discussion and the formula for shaft critical speed are given for the one- or two-blade rotor.

The use of complex variables in conjunction with Lagrange's equations has been found very convenient for the treatment of vibrations of rotating systems.

INTRODUCTION

A rotary-wing aircraft that has hinged blades will, under certain conditions, be subject to vibrations which derive their energy from the rotation of the rotor instead of from the air forces. The term "ground resonance" usually refers to vibrations of this type. Although such vibrations have apparently caused accidents in some rotary-wing aircraft and have impaired the flying qualities of others, very little attention has been given this problem in the literature. A theoretical analysis has therefore been undertaken, and the purpose of the present chapter is to present the theory and to describe the application of the theory to rotary-wing aircraft.

General vibration theory and its application to allied problems as well as to the particular problem of rotor vibration are discussed in references 1 to 4. A good general background for the present problem is provided in the chapters on rotating machinery and on self-excited vibrations in reference 1. References 2 and 3 treat in more abstract fashion the topics of rotation and damping. A discussion of the variety of modes of vibration that exist in rotors and a number of frequency formulas obtained by considering separately each degree of freedom are given in reference 4. This discussion does not, however, lead to a prediction of self-excited modes of vibration.

Experience has shown that two types of mechanical vibration may occur in rotors. The vibration frequency of the pylon is equal to the rotational speed in one type and is unequal in the other. The first type is sometimes called the even-frequency vibration or the one-to-one frequency, and the second type, the odd frequency. The one-to-one frequency vibration resembles the phenomenon occurring at a critical speed of the shaft of rotating machinery and will consequently be referred to in this chapter as a shaft critical vibration. The odd-frequency vibration is properly called a self-excited vibration.

A derivation of the characteristic equation for the whirling speeds of a three-blade rotor has been given by Wagner of the Kellett Autogiro Corporation. By considering only the case of a pylon having equal stiffness in all directions of deflection, Wagner has shortened the analysis by considering directly the equilibrium of forces and moments under conditions of steady circular whirling. Some examples of the dependence of whirling speed upon rotational speed are given, and the formula for the shaft critical speed is obtained.

In the present chapter, the theory also includes the effects of damping in the hinges and in the hub and the effects of different stiffnesses of pylon deflection in different directions. The method of analysis, particularly the use of complex

¹ Supersedes NACA Technical Note 3844 by Robert P. Coleman and Arnold M. Feingold, 1957.

variables in the equations of motion, is explained in some detail and all the previous results are shown to be a special case of the more general problem treated here.

SYMBOLS

a radial position of vertical hinge

A_{11}
 \bar{A}_{11}
 $\Delta A_{11} = \Delta \bar{A}_{11}$
 $A_{12} = \bar{A}_{12}$
 $A_{21} = \bar{A}_{21}$
 A_{22}
 \bar{A}_{22} } elements of the characteristic determinant (see eq. (31))

b distance from vertical hinge to center of mass of blade

B damping force per unit velocity of pylon displacement ($B_f = \frac{B_x + B_y}{2}$)

$\Delta B_f = \frac{B_x - B_y}{2}$

B_l coefficient defined in equation (35)

B_R coefficient defined in equation (34)

c, C_1, \dots, C_4 arbitrary constants

C_l coefficient defined in equation (35)

C_R coefficient defined in equation (34)

D time-derivative operator, d/dt

F dissipation function

I moment of inertia of blade about hinge,
 $m_b b^2 \left(1 + \frac{r^2}{b^2}\right)$

I_1, \dots, I_5 coefficients defined in expressions (37)

j, k indices and subscripts used with hinge coordinates (eq. (14))

K spring constant ($K_f = \frac{K_x + K_y}{2}$)

$\Delta K_f = \frac{K_x - K_y}{2}$

m effective mass of pylon ($m_f = \frac{m_x + m_y}{2}$)

m_b blade mass

$\Delta m_f = \frac{m_x - m_y}{2}$

M total effective mass of blades and pylon,
 $m_f + nm_b$

ΔM mass added at hub for vibration test

n total number of blades

r radius of gyration of blade about its center of mass

R_1, \dots, R_5 coefficients defined in expressions (37)

s stiffness ratio, K_y/K_x

t time

T kinetic energy

T_r kinetic energy of rotation of blade about its center of mass

T_k kinetic energy of translational motion of k th blade

T_r kinetic energy of pylon

V potential energy

x, y displacements

x_0, y_0 values of x and y when $t=0$

z complex displacement, $x+iy$

\bar{z} complex conjugate of z , $x-iy$

α angle between blades, $2\pi/n$

$\beta_0, \beta_1, \dots, \beta_k$ angular displacements of blades

β_{k_0} value of β_k when $t=0$

$\zeta_0, \zeta_1, \dots, \zeta_k$ variables representing hinge deflections when equations are expressed in fixed coordinate system

$\theta_0, \theta_1, \dots, \theta_k$ variables representing hinge deflections when equations are expressed in rotating coordinate system

$\lambda_x = \frac{B_x}{M_x} \left(\frac{B_x}{M_x \omega_r} \text{ in applications} \right)$

$\lambda_y = \frac{B_y}{M_y} \left(\frac{B_y}{M_y \omega_r} \text{ in applications} \right)$

$\lambda_\beta = \frac{B_\beta}{I} \left(\frac{B_\beta}{I \omega_r} \text{ in applications} \right)$

$\lambda_f = \frac{B_f}{M}$

$\lambda_a = \frac{B_a}{M}$

$\Delta \lambda_f = \frac{\Delta B_f}{M}$

$\Lambda_1 = \frac{a}{b \left(1 + \frac{r^2}{b^2}\right)}$

$\Lambda_2 = \frac{K_\beta}{I} \left(\frac{K_\beta}{I \omega_r^2} \text{ in applications} \right)$

$\Lambda_3 = \frac{\mu}{2 \left(1 + \frac{r^2}{b^2}\right)}$

μ mass ratio, $\frac{nm_b}{m_f + nm_b}$

ν_1, ν_2 expressions defined in equation (3)

ω angular velocity of rotor (the dimensionless ratio ω/ω_r is called ω in applications)

ω_a angular whirling velocity measured in rotating coordinate system (used in nondimensional form in applications)

ω_f angular whirling velocity measured in fixed coordinate system (used in nondimensional form in applications)

ω_r reference frequency, $\sqrt{K_x/M_x}$

Subscripts:

f fixed coordinate system

a rotating coordinate system

β hinge deflection

x, y component directions in fixed coordinate system

APPROACH TO THE VIBRATION PROBLEM

STABILITY AND INSTABILITY

If a vibrator were attached to a rotorcraft, several modes of vibration could be excited at any rotor speed. Only the modes that are likely to be excited during operation of the aircraft, however, are important.

In the present discussion, it is convenient to classify the modes of vibration according to the circumstances required for their excitation. The different types of vibration are identified analytically by the nature of the roots of the characteristic equation. A hinged rotor may encounter three types of vibration which, for convenience, are herein designated ordinary, self excited, and shaft critical. At zero or slow rotational speeds, an external force is required to excite vibration. The friction always present in such systems causes the vibration to be damped out when the force is removed. Modes of vibration requiring an external applied force to maintain them will be called ordinary vibrations. The mathematically idealized case of zero damping will also be considered an ordinary vibration when it is understood to be an approximation to a system actually damped. Self-excited modes of vibration are those with negative damping and are recognized analytically by the fact that a root of the characteristic equation is a complex number which has a negative imaginary part. A slight disturbance will tend to increase with time instead of damping out.

When a rotating system is not perfectly balanced, the centrifugal force of the unbalanced mass may excite vibrations that have peak amplitudes at certain rotational speeds. Vibration excited by unbalance and in resonance with the rotation will be called shaft critical vibration. This type occurs at the rotational speed at which the spring stiffness of the pylon is neutralized by the centrifugal force. In the analysis, the shaft critical vibration is recognized in rotating coordinates as a zero frequency and in fixed coordinates as a frequency equal to the rotational speed. The critical speeds of a rotating shaft are a common example of this class.

The purpose of a theory of rotor vibration is mainly to predict the occurrence of and, if possible, to show how to avoid self-excited and shaft critical vibrations.

CHOICE OF DEGREES OF FREEDOM

Of the large number of degrees of freedom of a hinged rotor, the important ones for the present problem have been found to be hinge deflection of the blades in the plane of rotation and horizontal deflections of the pylon. Other degrees of freedom, such as the flapping hinge motion of the blades, the bending or torsion of the blades, and the torsion of the drive shaft, are considered unimportant in the problem of self-excited oscillations. Some motions, such as landing-gear deflection, that produce lateral deflection at the top of the pylon may, however, be important.

PHYSICAL PARAMETERS

The theoretical results given later provide a means of predicting the natural frequencies and, in particular, the critical speeds and unstable speed ranges in terms of certain physical parameters, such as mass, stiffness, and length.

The successful application of the theory depends upon the determination of the proper values of these physical parameters for the aircraft or model being studied.

The important parameters to be determined are:

- a radial position of vertical hinge
- b distance from vertical hinge to center of mass of blade
- m_b mass of blade (Flexibility of the blade structure may have to be taken into account by the use of an effective value of m_b different from the actual blade mass. The effective blade mass can be taken as the value required to make the theory predict the correct pylon natural frequency when the rotor has a zero or very slow rotational speed.)
- I moment of inertia of blade about hinge,
 $m_b b^2 \left(1 + \frac{r^2}{b^2}\right)$
- K_β spring constant of self-centering springs, which can be determined by a force test or from the hinge frequency with the hub rigidly supported
- m_x, m_y effective mass of pylon for deflections in x - and y -directions
- K_x, K_y effective stiffness of pylon

The effective mass of the pylon is the value of a concentrated mass that would have the same kinetic energy expressed in terms of the deflections at the hub as the actual pylon and hub if it were placed at the rotor hub in the plane of rotation. The effective stiffness of the pylon is the stiffness of a spring that, if placed at the hub in the plane of rotation, would have the same potential energy in terms of deflections at the hub as the actual pylon. Equivalent definitions are that, if a simple spring and mass were imagined to be substituted at the hub in the plane of rotation for the pylon and hub, the natural frequency and the change of natural frequency with added mass would be the same as for the actual pylon.

An experimental method of measuring the effective mass m_x and stiffness K_x of the pylon is to replace the rotor by an approximately equal, rigid, concentrated mass ΔM at the hub and to measure the natural frequency for two or more values of this added mass. The quantities are then related by the equation

$$\omega_x = \sqrt{\frac{K_x}{m_x + \Delta M}}$$

or

$$\frac{1}{\omega_x^2} = \frac{1}{K_x} (m_x + \Delta M)$$

If measured values of $1/\omega_x^2$ are plotted against added mass ΔM and a straight line is drawn through the points, the intercept and the slope of the line will determine the effective values of K_x and m_x .

For the parameters a and b , the actual geometric lengths should be used unless the flexibility of the hinge offset arm a is comparable in magnitude with the hinge spring stiffness. In this case, it is recommended that an effective value of a be guessed and that b be determined by subtraction from the

correct geometric value of $a+b$.

The damping parameters may be defined by the form of a dissipation function F . The function

$$2F = B_x \dot{x}_f^2 + B_y \dot{y}_f^2 + \sum_{k=0}^{n-1} B_\beta \dot{\beta}_k^2$$

is equal to the rate of dissipation of energy by damping. The parameters B_x and B_y thus measure the damping force per unit velocity referred to linear displacements of the top of the pylon and B_β is the damping torque per unit angular velocity at a blade hinge. If the damping force per unit velocity is not a constant, effective values should be used that will represent the same dissipation of energy per cycle as actually occurs with a reasonable amplitude of vibration. The amplitude of free vibration in a single degree of freedom is given in terms of B_x , B_y , and B_β by

$$x_f = x_0 e^{-\frac{B_x}{2M}t}$$

$$y_f = y_0 e^{-\frac{B_y}{2M}t}$$

$$\beta_k = \beta_k e^{-\frac{B_\beta}{2I}t}$$

The damping parameters are probably the most difficult ones to measure accurately. In practice, it is advisable to make calculations for a given case, first on the basis of no damping and then with the use of the estimated values of the damping parameters.

MATHEMATICAL DEVELOPMENTS

METHOD OF ANALYSIS

The derivation of the characteristic equation that is used as the basis for predicting the unstable oscillations of a rotor is presented in this section. Readers interested solely in applications can omit this section and proceed immediately to the section entitled "Method of Applying Theory."

The method of analysis treats the equations of motion for small displacements from the equilibrium condition with steady rotation. A proper choice of coordinates leads to equations with constant coefficients. The solutions are exponential or trigonometric functions.

The mathematical manipulations involved in treating the motions of a mass in a plane of rotation are facilitated by the use of a complex variable. The typical disturbed motion obtained by solving the equations of motion is an elliptic whirling motion, which is represented in terms of a complex variable $z = x + iy$. At any instant, z represents the displacement of the pylon from its equilibrium position. An expression such as

$$z = ce^{i\omega_f t}$$

represents whirling of the pylon in a circle of radius c with angular velocity ω_f . The sign of ω_f determines the sense of the rotation. Two rotations in opposite sense with the same radius are equivalent to a vibratory motion in a straight line and are given as follows:

$$\begin{aligned} z &= c(e^{i\omega_f t} + e^{-i\omega_f t}) \\ &= 2c \cos \omega_f t \end{aligned}$$

Two opposite rotations of different radii are equivalent to whirling in an ellipse. A complex value of ω_f represents whirling in a spiral, which may be either a damped or a self-excited motion depending upon the sign of the imaginary part. A self-excited motion exists when the imaginary part of ω_f is negative, and the magnitude of z increases with time.

The displacements may be referred to a fixed or to a rotating coordinate system. If z_f and z_a are the displacements with respect to a fixed and to a rotating reference system, respectively,

$$z_f = z_a e^{i\omega t}$$

$$z_a = c e^{i\omega_a t}$$

then

$$z_f = c e^{i(\omega_a + \omega)t}$$

A whirling speed ω_a with respect to the rotating coordinates thus corresponds to a whirling speed $\omega_f = \omega_a + \omega$ with respect to the fixed coordinates. A shaft critical vibration corresponds to $\omega_a = 0$ in the rotating coordinate system or to $\omega_f = \omega$ in the fixed coordinate system.

EXAMPLE OF ROTOR WITH LOCKED HINGES

An example that involves a partial use of complex variables is given on page 253 of reference 2. The problem given there of a mass particle moving on the inner surface of a rotating spherical bowl is mathematically equivalent to the disturbed motion of a flywheel and shaft or of a rotor with locked hinges. The equations of motion obtained in real form in rotating coordinates

$$\left. \begin{aligned} \ddot{x}_a - 2\omega \dot{y}_a - \omega^2 x_a &= -\frac{B_a \dot{x}_a}{M} - \frac{K}{M} x_a \\ \ddot{y}_a + 2\omega \dot{x}_a - \omega^2 y_a &= -\frac{B_a \dot{y}_a}{M} - \frac{K}{M} y_a \end{aligned} \right\} \quad (1)$$

are combined in the single equation

$$\ddot{z}_a + \left(2i\omega + \frac{B_a}{M}\right) \dot{z}_a + \left(\frac{K}{M} - \omega^2\right) z_a = 0 \quad (2)$$

where

$$z_a = x_a + iy_a$$

is the complex position vector in the rotating coordinate system. The complete solution, if small damping is assumed, is

$$z_a e^{i\omega t} = C_1 e^{-\nu_1 t + i\omega_f t} + C_2 e^{-\nu_2 t - i\omega_f t} \quad (3)$$

where

$$\nu_1 = \frac{1}{2} \frac{B_a}{M} \left(1 - \frac{\omega}{\omega_f}\right)$$

$$\nu_2 = \frac{1}{2} \frac{B_a}{M} \left(1 + \frac{\omega}{\omega_f}\right)$$

The path of the motion is represented by rotations of a complex vector in a plane.

The use of a complex variable has thus cut in half the number of equations to be handled and has yielded a solution from which the geometric path of the motion may easily be reconstructed. The advantage of the z -notation is not fully

realized, however, unless it is used from the very beginning of the problem. The close similarity of this problem to the rotor-vibration problem makes it worthwhile to show the full application of the z -notation to the preceding example. The complex variable z_a at any instant determines the position of the mass particle relative to the rotating coordinate system. If the position in a fixed coordinate system is denoted by z_f ,

$$z_f = z_a e^{i\omega t} \tag{4}$$

and z_a can be treated as a generalized coordinate in the Lagrangian equations of motion. The kinetic- and potential-energy expressions can be immediately written as

$$\begin{aligned} T &= \frac{1}{2} M \dot{z}_f \dot{\bar{z}}_f \\ &= \frac{1}{2} M (\dot{z}_a + i\omega z_a)(\dot{\bar{z}}_a - i\omega \bar{z}_a) \\ V &= \frac{1}{2} K z_a \bar{z}_a \end{aligned}$$

A dissipation function for damping that depends upon motion relative to the rotating system can be written

$$F = \frac{1}{2} B_a \dot{z}_a \dot{\bar{z}}_a$$

The equations of motion are now obtained by considering z_a and \bar{z}_a as generalized coordinates in the Lagrangian equations. Substitution in the equation

$$\frac{d}{dt} \left(\frac{\partial T}{\partial \dot{z}_a} \right) - \frac{\partial T}{\partial z_a} + \frac{\partial F}{\partial \dot{z}_a} + \frac{\partial V}{\partial z_a} = 0$$

thus yields the equation previously given

$$\ddot{z}_a + \left(2i\omega + \frac{B_a}{M} \right) \dot{z}_a + \left(\frac{K}{M} - \omega^2 \right) z_a = 0$$

The same method can be used to obtain the equations of motion in the fixed coordinate system. In this case,

$$\left. \begin{aligned} T &= \frac{1}{2} M \dot{z}_f \dot{\bar{z}}_f \\ V &= \frac{1}{2} K z_f \bar{z}_f \\ F &= \frac{1}{2} B_a (\dot{z}_f - i\omega z_f)(\dot{\bar{z}}_f + i\omega \bar{z}_f) \end{aligned} \right\} \tag{5}$$

The equation of motion in terms of z_f becomes

$$\ddot{z}_f + \frac{B_a}{M} (\dot{z}_f - i\omega z_f) + \frac{K}{M} z_f = 0 \tag{6}$$

and the solution for small values of damping is

$$z_f = C_1 e^{-\frac{B_a}{2M} \left(1 - \frac{\omega}{\sqrt{K/M}} \right) t + i\sqrt{K/M} t} + C_2 e^{-\frac{B_a}{2M} \left(1 + \frac{\omega}{\sqrt{K/M}} \right) t - i\sqrt{K/M} t} \tag{7}$$

This solution shows that the motion consists of two circular vibrations in opposite directions and, moreover, that for $\omega > \sqrt{K/M}$ the first term represents unstable motion; that is, the vibration has negative damping.

This example illustrates a shaft critical speed for $\omega = \sqrt{K/M}$ and a self-excited instability for $\omega > \sqrt{K/M}$. A discussion of the physical picture of this instability due to damping is given on page 293 of reference 1.

The effect of damping in a nonrotating part of the system can be included in the analysis merely by adding to the previous dissipation function the term

$$\frac{1}{2} B_f \dot{z}_f \dot{\bar{z}}_f$$

The equation of motion then becomes

$$M \ddot{z}_f + B_f \dot{z}_f + B_a (\dot{z}_f - i\omega z_f) + K z_f = 0 \tag{8}$$

The solution for small values of damping becomes

$$\begin{aligned} Z_f &= C_1 e^{\left[\frac{B_f}{2M} \frac{B_a}{2M} \left(1 - \frac{\omega}{\sqrt{K/M}} \right) + i\sqrt{K/M} \right] t} + \\ &C_2 e^{\left[\frac{B_f}{2M} \frac{B_a}{2M} \left(1 + \frac{\omega}{\sqrt{K/M}} \right) - i\sqrt{K/M} \right] t} \end{aligned} \tag{9}$$

The motion is now unstable above the speed

$$\omega = \sqrt{\frac{K}{M}} \left(1 + \frac{B_f}{B_a} \right) \tag{10}$$

HINGED ROTOR

Inclusion of the effect of hinge motion in the plane of rotation increases the number of degrees of freedom and the number of equations of motion. For example, three hinged blades and two directions of pylon deflection give five degrees of freedom to be considered. If special linear combinations of the hinge deflections β_k are used as generalized coordinates, no more than four degrees of freedom need be considered simultaneously. The use of complex variables reduces these four equations to two equations.

Appropriate variables in the rotating system for a three-bladed rotor are

$$\left. \begin{aligned} \theta_0 &= \frac{bi}{3} (\beta_0 + \beta_1 + \beta_2) \\ \theta_1 &= \frac{bi}{3} \left(\beta_0 + \beta_1 e^{\frac{2\pi i}{3}} + \beta_2 e^{\frac{4\pi i}{3}} \right) \\ \theta_2 &= \frac{bi}{3} \left(\beta_0 + \beta_1 e^{\frac{4\pi i}{3}} + \beta_2 e^{\frac{8\pi i}{3}} \right) \end{aligned} \right\} \tag{11}$$

These variables and their complex conjugates satisfy the relations

$$\begin{aligned} \bar{\theta}_1 &= -\theta_2 \\ \bar{\theta}_2 &= -\theta_1 \end{aligned}$$

and also

$$\begin{aligned} \theta_0 \bar{\theta}_0 + \theta_1 \bar{\theta}_1 + \theta_2 \bar{\theta}_2 &= -\theta_0^2 + 2\theta_1 \bar{\theta}_1 \\ &= \frac{b^2}{3} (\beta_0^2 + \beta_1^2 + \beta_2^2) \end{aligned}$$

The variables β_k , by virtue of their meaning, are referred to a rotating coordinate system. The special linear combinations of the β_k denoted by θ_k are also referred to a rotating

coordinate system. The appropriate variables to represent the hinge deflections when fixed coordinates are used are defined by

$$\zeta_k = \theta_k e^{i\omega t} \quad (12)$$

and $\bar{\zeta}_k$ is the complex conjugate of ζ_k .

Geometrically, θ_1 or ζ_1 is the complex vector representing the displacement due to hinge deflection of the center of mass of all the blades, just as z represents the position of the shaft due to pylon deflection. It will be shown later that in equations of motion, θ_1 is coupled with z and θ_0 is an independent principal coordinate. Equations (11) when solved for β_0 , β_1 , and β_2 become

$$\begin{aligned} \theta_0 + \theta_1 + \theta_2 &= bi\beta_0 \\ \theta_0 + \theta_1 e^{-i\alpha} + \theta_2 e^{i\alpha} &= bi\beta_1 \\ \theta_0 + \theta_1 e^{i\alpha} + \theta_2 e^{-i\alpha} &= bi\beta_2 \end{aligned}$$

Then, in a mode involving θ_1 ,

$$\left. \begin{aligned} \theta_0 &= 0 \\ \theta_1 &= \frac{b}{2} e^{i\omega t} \\ \theta_2 &= -\bar{\theta}_1 \\ \beta_0 &= \sin \omega t \\ \beta_1 &= \sin (\omega t - \alpha) \\ \beta_2 &= \sin (\omega t + \alpha) \end{aligned} \right\} \quad (13)$$

Equations (13) show that in the θ_1 -mode, the blades are undergoing sinusoidal vibrations 120° out of phase with one another in a manner analogous to three-phase electrical currents.

General formulas for any number of blades are

$$\left. \begin{aligned} \theta_j &= \frac{bi}{n} \sum_{k=0}^{n-1} \beta_k e^{i(j-k)\alpha} \\ \alpha &= \frac{2\pi}{n} \\ \bar{\theta}_j &= -\theta_{n-j} \\ \theta_n &= \theta_0 \\ \sum_{k=0}^{n-1} \theta_k \beta_k &= \frac{b^2}{n} = \sum_{k=0}^{n-1} \beta_k^2 \end{aligned} \right\} \quad (14)$$

DERIVATION OF EQUATIONS OF MOTION

The equations of motion and the characteristic equation of whirling speeds are herein derived for the general case of three or more equal blades on a pylon that may have different stiffness properties in different directions of deflection. The effects of damping in the blade hinges and in the pylon are included. The equations are first formulated in a nonrotating reference system. The required modifications are then given for the case of isotropic support stiffness.

The corresponding equations referred to the rotating coordinates are then obtained.

Let the position of the center of mass of the k th blade be represented by the complex quantity z_k in the plane of rotation. (See fig. I-1.) Let the bending deflection of the pylon be represented by z_f in a nonrotating coordinate system and let β_k be the hinge deflection of the k th blade. Then

$$z_k = z_f + (a + b e^{i\beta_k}) e^{i(\alpha k + \omega t)} \quad (15)$$

The complex velocity is

$$\dot{z}_k = \dot{z}_f + [bi\dot{\beta}_k e^{i\beta_k} + i\omega(a + b e^{i\beta_k})] e^{i(\alpha k + \omega t)} \quad (16)$$

Because only small displacements are being considered, the exponential factors containing β_k can be expanded and only the terms that lead to quadratic terms for the kinetic-energy expression need be considered.

Some terms can be ignored either because they cancel after summation for all the blades or because the corresponding derivative expressions in the Lagrangian equations vanish. The substitution

$$e^{i\beta_k} = 1 + i\beta_k - \frac{\beta_k^2}{2}$$

leads to the following expression for the kinetic energy of translational motion of the k th blade:

$$T_k = \frac{1}{2} m_k \dot{z}_k \bar{\dot{z}}_k \quad (17)$$

where

$$\begin{aligned} \dot{z}_k \bar{\dot{z}}_k &= \dot{z}_f \bar{\dot{z}}_f + \dot{z}_f bi(\dot{\beta}_k + i\omega\beta_k) e^{i(\alpha k + \omega t)} + \\ &\dot{z}_f (-bi)(\dot{\beta}_k - i\omega\beta_k) e^{-i(\alpha k + \omega t)} + b^2 \dot{\beta}_k^2 - \omega^2 ab\beta_k^2 \end{aligned}$$

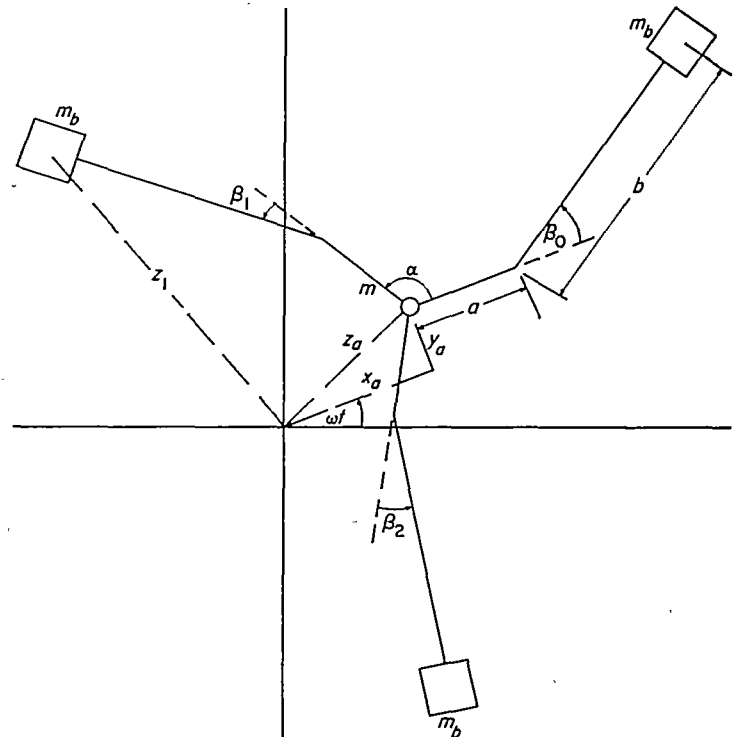

FIGURE I-1.—Simplified mechanical system representing rotor.

The kinetic energy of rotation about the center of mass of the blade is

$$T_r = \frac{1}{2} m_b r^2 \dot{\beta}_k^2 \tag{18}$$

The effective mass of the pylon may be different in the x_f - and in the y_f -directions. Allowance for this possibility is made by writing the kinetic energy of the pylon as

$$T_s = \frac{1}{2} (m_x \dot{x}_f^2 + m_y \dot{y}_f^2) = \frac{1}{2} \left[m_f \dot{z}_f \dot{\bar{z}}_f + \Delta m_f \left(\frac{\dot{z}_f^2 + \dot{\bar{z}}_f^2}{2} \right) \right] \tag{19}$$

where

$$m_f = \frac{m_x + m_y}{2}$$

$$\Delta m_f = \frac{m_x - m_y}{2}$$

The total kinetic energy is the sum of the expressions for the separate kinetic energies.

The pylon spring constant may differ in the x_f - and in the y_f -directions and, consequently, the potential energy can be expressed as

$$V = \frac{1}{2} \left(K_f z_f \bar{z}_f + \Delta K_f \frac{z_f^2 + \bar{z}_f^2}{2} + \sum_{k=0}^{n-1} K_\beta \beta_k^2 \right) \tag{20}$$

The effect of damping will be expressed with the aid of a dissipation function. If damping exists in the pylon, in the rotating shaft, and in the hinges, this function becomes

$$F = \frac{1}{2} \left(B_f \dot{z}_f \dot{\bar{z}}_f + \Delta B_f \frac{\dot{z}_f^2 + \dot{\bar{z}}_f^2}{2} + B_a \dot{z}_a \dot{\bar{z}}_a + \sum_{k=0}^{n-1} B_\beta \dot{\beta}_k^2 \right) \tag{21}$$

The sum of the various energy expressions for all the blades, expressed in terms of the variables z_f and ζ_k in the nonrotating coordinates, becomes

$$T = \frac{1}{2} \left\{ \Delta m_f \frac{\dot{z}_f^2 + \dot{\bar{z}}_f^2}{2} + (m_f + n m_b) \dot{z}_f \dot{\bar{z}}_f + n m_b \left[(\dot{\bar{z}}_f \dot{\zeta}_1 + \dot{z}_f \dot{\bar{\zeta}}_1) + \left(1 + \frac{r^2}{b^2} \right) \sum_{k=0}^{n-1} (\dot{\zeta}_k - i \omega \zeta_k) (\dot{\bar{\zeta}}_k + i \omega \bar{\zeta}_k) - \omega^2 \frac{a}{b} \sum_{k=0}^{n-1} \zeta_k \bar{\zeta}_k \right] \right\} \tag{22}$$

$$V = \frac{1}{2} \left(\Delta K_f \frac{z_f^2 + \bar{z}_f^2}{2} + K_f z_f \bar{z}_f + \frac{n K_\beta}{b^2} \sum_{k=0}^{n-1} \zeta_k \bar{\zeta}_k \right)$$

$$F = \frac{1}{2} \left[\Delta B_f \frac{\dot{z}_f^2 + \dot{\bar{z}}_f^2}{2} + B_f \dot{z}_f \dot{\bar{z}}_f + B_a (\dot{z}_f - i \omega z_f) (\dot{\bar{z}}_f + i \omega \bar{z}_f) + \frac{n B_\beta}{b^2} \sum_{k=0}^{n-1} (\dot{\zeta}_k - i \omega \zeta_k) (\dot{\bar{\zeta}}_k + i \omega \bar{\zeta}_k) \right]$$

The Lagrangian equations of motion are

$$\left. \begin{aligned} \frac{d}{dt} \left(\frac{\partial T}{\partial \dot{\bar{z}}_f} \right) - \frac{\partial T}{\partial \bar{z}_f} + \frac{\partial F}{\partial \dot{\bar{z}}_f} + \frac{\partial V}{\partial \bar{z}_f} &= 0 \\ \frac{d}{dt} \left(\frac{\partial T}{\partial \dot{\zeta}_1} \right) - \frac{\partial T}{\partial \zeta_1} + \frac{\partial F}{\partial \dot{\zeta}_1} + \frac{\partial V}{\partial \zeta_1} &= 0 \end{aligned} \right\} \tag{23}$$

and similar expressions for the other variables. The equations of motion in fixed coordinates then become

$$\left. \begin{aligned} (n + n m_b) \ddot{z}_f + B \dot{z}_f + B_a (\dot{z}_f - i \omega z_f) + K z_f + \Delta m \ddot{\bar{z}}_f + \Delta B \dot{\bar{z}}_f + \Delta K \bar{z}_f + n m_b \ddot{\zeta}_1 &= 0 \\ n m_b \ddot{z}_f + 2 n m_b \left[\left(1 + \frac{r^2}{b^2} \right) (\dot{\zeta}_1 - 2 i \omega \zeta_1 - \omega^2 \zeta_1) + \frac{B_\beta}{m_b b^2} (\zeta_1 - i \omega \zeta_1) + \omega^2 \frac{a}{b} \zeta_1 + \frac{K_\beta}{m_b b^2} \zeta_1 \right] &= 0 \\ n m_b \left[\left(1 + \frac{r^2}{b^2} \right) (\dot{\zeta}_k - 2 i \omega \zeta_k - \omega^2 \zeta_k) + \frac{B_\beta}{m_b b^2} (\zeta_k - i \omega \zeta_k) + \omega^2 \frac{a}{b} \zeta_k + \frac{K_\beta}{m_b b^2} \zeta_k \right] &= 0 \end{aligned} \right\} \tag{24}$$

where ζ_k refers to the ζ -variables other than ζ_1 and ζ_{n-1} . The complex conjugates of these equations are also obtained but give no additional information. Each complex equation is, of course, equivalent to two real equations. It is noticed that the first two equations contain only the variables z_f , \bar{z}_f , and ζ_1 and that the third equation represents $n-2$ equations, each containing one independent principal coordinate ζ_k . The physical meaning of this partial separation of variables is that a blade motion represented by ζ_1 involves a motion of the common center of mass of the blades and, thus, a coupling effect with the pylon. Blade motions in which the common center of mass does not move are represented by ζ_0, \dots, ζ_n . For three blades, the only such mode is the one corresponding to ζ_0 . In this mode, all the blades move in phase; the motion is always damped and does not lead to instability.

The equations of motion of a one- or two-blade rotor are somewhat different from equations (24). The difference is connected with the circumstance that a rotor of three or more equal blades has no preferred direction in its plane; whereas, a one- or two-blade rotor has different dynamic properties in directions along and normal to the blades. Only a brief statement and the final equation for shaft critical speed will be given for the one- or two-blade rotor.

The equations of motion involving z_f and ζ_1 can be written more compactly by use of the notation

$$D = \frac{d}{dt} \quad D^2 = \frac{d^2}{dt^2}$$

and the substitutions

$$\frac{B_f}{M} = \lambda_f \quad \frac{B_\beta}{m_b b^2 \left(1 + \frac{r^2}{b^2} \right)} = \lambda_\beta$$

$$\frac{B_a}{M} = \lambda_a \quad \frac{a}{b\left(1 + \frac{r^2}{b^2}\right)} = \Delta_1$$

$$\frac{\Delta B_f}{M} = \Delta \lambda_f \quad \frac{K_f}{m_b b^2 \left(1 + \frac{r^2}{b^2}\right)} = \Delta_2$$

$$\frac{nm_b}{m_f + nm_b} = \mu$$

Then

$$\left. \begin{aligned} \left[D^2 + \lambda_f D + \lambda_a (D - i\omega) + \frac{K_f}{M} \right] z_f + \left(\frac{\Delta m_f}{M} D^2 + \Delta \lambda_f D + \frac{\Delta K_f}{M} \right) \bar{z}_f + \mu D^2 \zeta_1 = 0 \\ \frac{1}{2\left(1 + \frac{r^2}{b^2}\right)} D^2 z_f + [(D - i\omega)^2 + \lambda_f (D - i\omega) + \omega^2 \Delta_1 + \Delta_2] \zeta_1 = 0 \end{aligned} \right\} \quad (25)$$

or, briefly,

$$\left. \begin{aligned} A_{11}(D) z_f + \Delta A_{11}(D) \bar{z}_f + A_{12}(D) \zeta_1 = 0 \\ A_{21}(D) z_f + A_{22}(D) \zeta_1 = 0 \end{aligned} \right\} \quad (26)$$

THE CHARACTERISTIC EQUATION

The general form of solution of equations (26) is an elliptic whirling motion that can be represented by

$$\left. \begin{aligned} z_f = C_1 e^{i\omega_f t} + C_2 e^{-i\bar{\omega}_f t} \\ \bar{z}_f = \bar{C}_1 e^{-i\bar{\omega}_f t} + \bar{C}_2 e^{i\omega_f t} \\ \zeta_1 = C_3 e^{i\omega_f t} + C_4 e^{-i\bar{\omega}_f t} \end{aligned} \right\} \quad (27)$$

Special cases of this motion include whirling in a circle ($C_2 = C_4 = 0$) and linear vibration ($C_1 = C_2$, $C_3 = C_4$). Substitution of equations (27) in equation (26) gives

$$\left. \begin{aligned} [A_{11}(i\omega_f) C_1 + \Delta A_{11}(i\omega_f) \bar{C}_2 + A_{12}(i\omega_f) C_3] e^{i\omega_f t} + [A_{11}(-i\bar{\omega}_f) C_2 + \Delta A_{11}(-i\bar{\omega}_f) \bar{C}_1 + A_{12}(-i\bar{\omega}_f) C_4] e^{-i\bar{\omega}_f t} = 0 \\ [A_{21}(i\omega_f) C_1 + A_{22}(i\omega_f) C_3] e^{i\omega_f t} + [A_{21}(-i\bar{\omega}_f) C_2 + A_{22}(-i\bar{\omega}_f) C_4] e^{-i\bar{\omega}_f t} = 0 \end{aligned} \right\} \quad (28)$$

In order for equations (27) to be a solution of equations (26), equations (28) must be satisfied for each value of t . The coefficient of each time factor $e^{i\omega_f t}$ or $e^{-i\bar{\omega}_f t}$ must therefore separately vanish. Because each bracketed expression represents a complex quantity that vanishes, its complex conjugate also must vanish. The condition for a solution can therefore be expressed by the vanishing of the first bracketed terms and the complex conjugates of the second bracketed terms. Hence,

$$\left. \begin{aligned} A_{11}(i\omega_f) C_1 + \Delta A_{11}(i\omega_f) \bar{C}_2 + A_{12}(i\omega_f) C_3 = 0 \\ A_{21}(i\omega_f) C_1 + A_{22}(i\omega_f) C_3 = 0 \\ \Delta \bar{A}_{11}(i\omega_f) C_1 + \bar{A}_{11}(i\omega_f) \bar{C}_2 + \bar{A}_{12}(i\omega_f) \bar{C}_4 = 0 \\ \bar{A}_{21}(i\omega_f) \bar{C}_2 + \bar{A}_{22}(i\omega_f) \bar{C}_4 = 0 \end{aligned} \right\} \quad (29)$$

where $\bar{A}_{11}(i\omega_f)$ is the complex conjugate of $A_{11}(-i\bar{\omega}_f)$ and is obtained from $A_{11}(i\omega_f)$ by changing $i\omega$ to $-i\omega$ without changing $i\omega_f$. The characteristic equation giving the rotational speeds is the determinant of the coefficients of C_1 , \bar{C}_2 , C_3 , and \bar{C}_4 equated to zero. With the second and third

columns interchanged for symmetry, the determinant becomes

$$\begin{vmatrix} A_{11} & A_{12} & \Delta A_{11} & 0 \\ A_{21} & A_{22} & 0 & 0 \\ \Delta \bar{A}_{11} & 0 & \bar{A}_{11} & \bar{A}_{12} \\ 0 & 0 & \bar{A}_{21} & \bar{A}_{22} \end{vmatrix} = 0 \quad (30)$$

The expanded form of this determinant is

$$(A_{11} A_{22} - A_{12} A_{21})(\bar{A}_{11} \bar{A}_{22} - \bar{A}_{12} \bar{A}_{21}) - \Delta A_{11} \Delta \bar{A}_{11} A_{22} \bar{A}_{22} = 0 \quad (31)$$

where

$$A_{11} = -\omega_f^2 + i\omega_f \lambda_f + i\lambda_a (\omega_f - \omega) + \frac{K_f}{M}$$

$$\bar{A}_{11} = -\omega_f^2 + i\omega_f \lambda_f + i\lambda_a (\omega_f + \omega) + \frac{K_f}{M}$$

$$\Delta A_{11} = \Delta \bar{A}_{11} = -\frac{\Delta m_f}{M} \omega_f^2 + i\omega_f \Delta \lambda_f + \frac{\Delta K_f}{M}$$

$$A_{12}A_{21} = \bar{A}_{12}\bar{A}_{21} = \frac{\mu}{2\left(1 + \frac{\gamma^2}{\delta^2}\right)} \omega_f^4 = \Lambda_3 \omega_f^4$$

$$A_{22} = -(\omega_f - \omega)^2 + i\lambda_\beta(\omega_f - \omega) + \omega^2\Lambda_1 + \Lambda_2$$

$$\bar{A}_{22} = -(\omega_f + \omega)^2 + i\lambda_\beta(\omega_f + \omega) + \omega^2\Lambda_1 + \Lambda_2$$

The roots ω_f of this equation are the characteristic whirling speeds of the rotor.

For the case of isotropic supports,

$$\Delta A_{11} = 0$$

and the equations of motion are satisfied by equations (27) with $C_2 = C_4 = 0$.

The characteristic equation is then simply

$$A_{11}A_{22} - A_{12}A_{21} = 0 \tag{32}$$

In a rotating coordinate system, the complex coordinates are z_a and θ_1 , where

$$z_f = z_a e^{i\omega t}$$

$$\zeta_1 = \theta_1 e^{i\omega t}$$

Then

$$Dz_f = (Dz_a + i\omega z_a) e^{i\omega t}$$

$$D\zeta_1 = (D\theta_1 + i\omega\theta_1) e^{i\omega t}$$

If the whirling speed in rotating coordinates is represented by ω_a ,

$$z_a = C_1 e^{i\omega_a t}$$

$$\theta_1 = C_2 e^{i\omega_a t}$$

The characteristic equation is then obtained by substituting $\omega_a + \omega$ for ω_f :

$$A_{11}(\omega_a + \omega)A_{22}(\omega_a + \omega) - A_{12}(\omega_a + \omega)A_{21}(\omega_a + \omega) = 0 \tag{33}$$

The characteristic equation can thus be stated in terms of a whirling speed in either the fixed or the rotating coordinate system.

METHOD OF APPLYING THEORY
APPLICATION NEGLECTING DAMPING

In plotting curves for use in applications of the theory, it is convenient to consider one of the pylon bending frequencies $\omega_r = \sqrt{K_x/M_x}$ as a reference frequency and to refer all other frequencies as well as the rotational speed ω to the reference frequency as unit. The number of independent parameters is thus reduced by 1. All quantities in equations (31) to (33) are then expressed nondimensionally.

The natural whirling speeds and the three types of vibration—ordinary, self excited, and shaft critical—can now be predicted from a study of the roots of equation (31) in which ω_f is considered a function of ω for fixed values of the other parameters.

The case of no damping will be considered first. Because equation (31) with damping terms omitted is of the fourth degree in ω_f^2 and of only the second degree in ω^2 , it may be solved conveniently by first choosing values of ω_f and then solving the equation for ω^2 . Similar indirect methods can

be used with equations (32) and (33). Special methods to be used when damping is included will be discussed later.

The meaning of equations (31) to (33) will be illustrated by examples. The real part of ω_f will be plotted against ω for selected values of the parameters Λ_1 , Λ_2 , Λ_3 , and δ . The simplest case is that in which the mass of the blades is so small that any force on the pylon due to blade motions is negligible. The pylon motions are then independent of the blade motions. This case is obtained by putting $\Lambda_3 = 0$. The characteristic equation (31), (32), or (33) then factors into expressions yielding straight lines and hyperbolas.

An example of a rotor with particular values of the parameters is plotted as long-dash lines in figure I-2. The horizontal straight lines correspond to pylon bending and the slanting hyperbolas correspond to hinge deflection. Each curve represents the trend of one of the real roots ω_f . As Λ_3 increases slightly from zero, the greatest changes in the curves occur in the vicinity of the intersections of the straight lines with the hyperbolas. Here each branch breaks away from the intersection and rejoins the other branch. At a gap, such as C in figure I-2, the number of real roots of the frequency equation is reduced by 1-2. The missing roots are complex conjugate numbers, and one of them must have a negative imaginary part, which implies a self-excited vibration.

Consider the interpretation of figure I-2 as ω is gradually increased from zero. At zero rotational speed, the values of ω_f are the natural frequencies that could be excited as ordinary vibration by applied vibrating force. Positive and negative values occur in pairs of equal magnitude and correspond to linear vibration modes represented in complex notation as

$$z_f = c(e^{i\omega_f t} + e^{-i\omega_f t})$$

As ω increases from zero, the positive and negative values of ω_f no longer are equal in magnitude. The normal modes are therefore whirling motions with angular velocities equal to the plotted values of ω_f .

The shaft critical speed is the rotational speed at which $\omega_f = \omega$ and hence is given by the point A where a 45° line

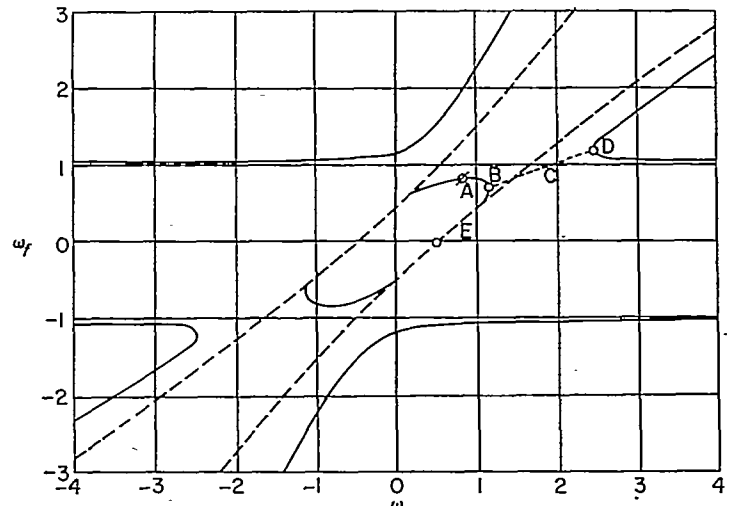

FIGURE I-2.—The effect of coupling between pylon and hinge motions.

through the origin intersects the ω_f -curve. This speed corresponds to the peak for vibrations excited by unbalance in the rotating system. As ω increases above the shaft critical speed, the modes of whirling are stable until, for the case of no damping, the value of ω_f becomes complex at the value of ω at which a vertical line is tangent to the plotted curve. This point B is the beginning of the self-excited range. At the point D, the motion again becomes stable. The real part of ω_f is plotted in the region C as a short-dash line. The complex roots in the region C have been calculated and plotted in figure I-3.

The point E, at which $\omega_f=0$, is of some interest. At this speed, a vibration of the blades could be excited by a steady force ($\omega_f=0$, $\omega_a = -\omega$), such as the force of gravity if the plane of the rotor is not horizontal.

Because the most important information to be obtained from the frequency equation is the critical value of ω for the shaft critical and self-excited vibrations, a set of charts that gives this information for a large variety of values of the physical parameters has been prepared. These charts are given in figures I-4 to I-6, which correspond to values of stiffness ratio $K_y/K_x = s$ of 1, ∞ , and 0, respectively. The use of the charts is illustrated by a numerical example. Suppose the values of the parameters for a certain rotor are $\Delta_1=0.07$, $\Delta_2=0.22$, $\Delta_3=0.1$, $s=1$, and $\omega_r=155$ cycles per minute. A straight line, such as AB in figure I-4, is first drawn to represent the function $\omega^2\Delta_1+\Delta_2$. This line intersects contours $\Delta_3=0.1$ at $\omega^2=0.77$ for the shaft critical point and $\omega^2=1.6$ and 4.85 for the beginning and for the end of the self-excited range, respectively. With a reference frequency of 155 cycles per minute, these values correspond to actual rotational speeds of 136, 196, and 342 rpm.

All possible values of Δ_1 , Δ_2 , and Δ_3 are thus covered by suitably changing the straight line AB. The general effect of the stiffness ratio s is not large; any case can therefore be estimated with a fair degree of accuracy by use of figures I-4 to I-6.

POSSIBILITY OF AVOIDING OCCURENCE OF VIBRATION

Figures I-4 to I-6 can also be used for the inverse problem of finding the values of the parameters that are required to obtain given values of critical rotational speed. These figures show that to eliminate entirely the self-excited instability requires that Δ_1 be equal to or greater than 1.

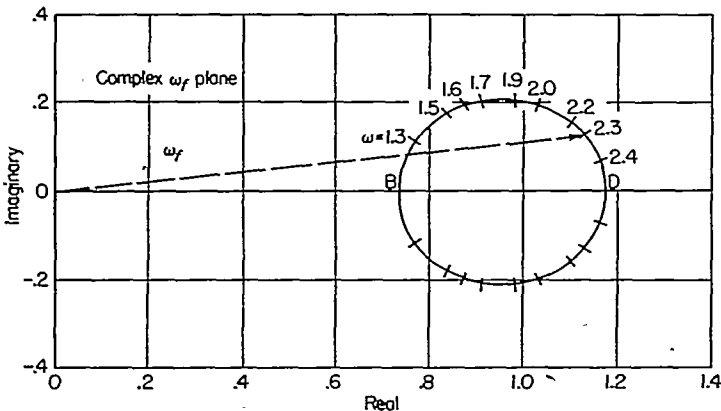

FIGURE I-3.—The complex frequency in the unstable range for $\Delta_1=0.07$, $\Delta_2=0.22$, $\Delta_3=0.1$, and $s=1$.

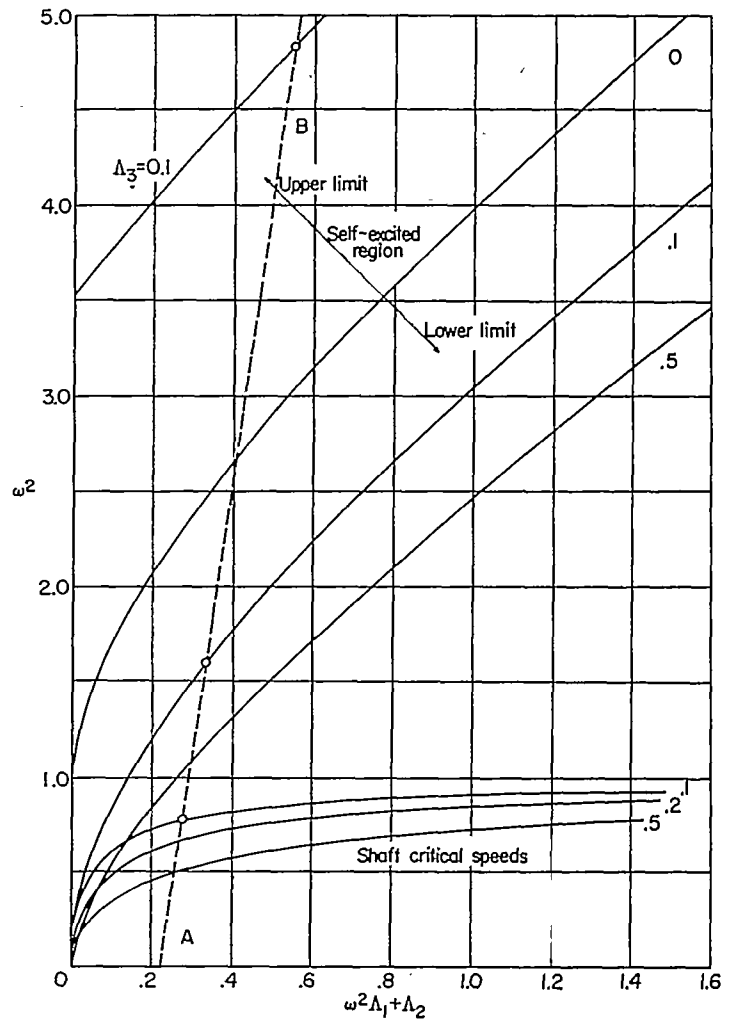

FIGURE I-4.—Stability chart for $s=1$.

The shaft critical instability can be entirely eliminated only with a value of Δ_1 in a small range near 4 and with $s=\infty$ or $s=0$. These values of Δ_1 differ radically from present designs in which a typical value is 0.07.

The satisfactory requirement of keeping the instabilities outside the operating range of rotational speed is found by first picking a reasonable value of the pylon frequency $\sqrt{K_x/M_x}$ to fix the scale unit for ω and by then observing the combinations of Δ_1 and Δ_2 that can be used to avoid the critical Δ_3 -contours.

EFFECT OF DAMPING

The effect of damping has been included in equation (31) through the parameters λ_f , $\Delta\lambda_f$, λ_a , and λ_b . A method of computation similar to that used in flutter theory appears preferable to attempting to solve the equation directly for ω_f . The beginning and the end of an unstable range can be found by the following method: At a limit point between a stable and an unstable speed range, the value of ω_f is real. Equation (31) is first separated into real and imaginary parts with ω_f considered real. Each part is considered a functional relation between ω_f and ω and is plotted for a given set of values of the parameters. The intersections of the real and the imaginary equations give the rotor speeds and frequencies corresponding to the beginning and the end of the unstable

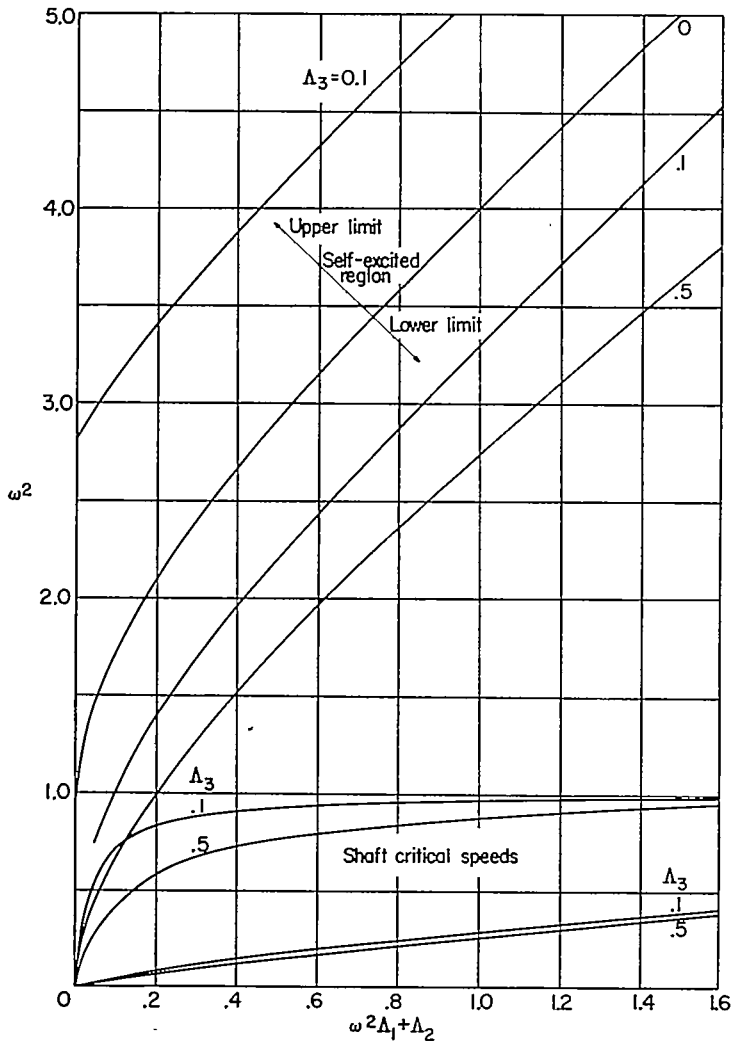

FIGURE I-5.—Stability chart for $s = \infty$.

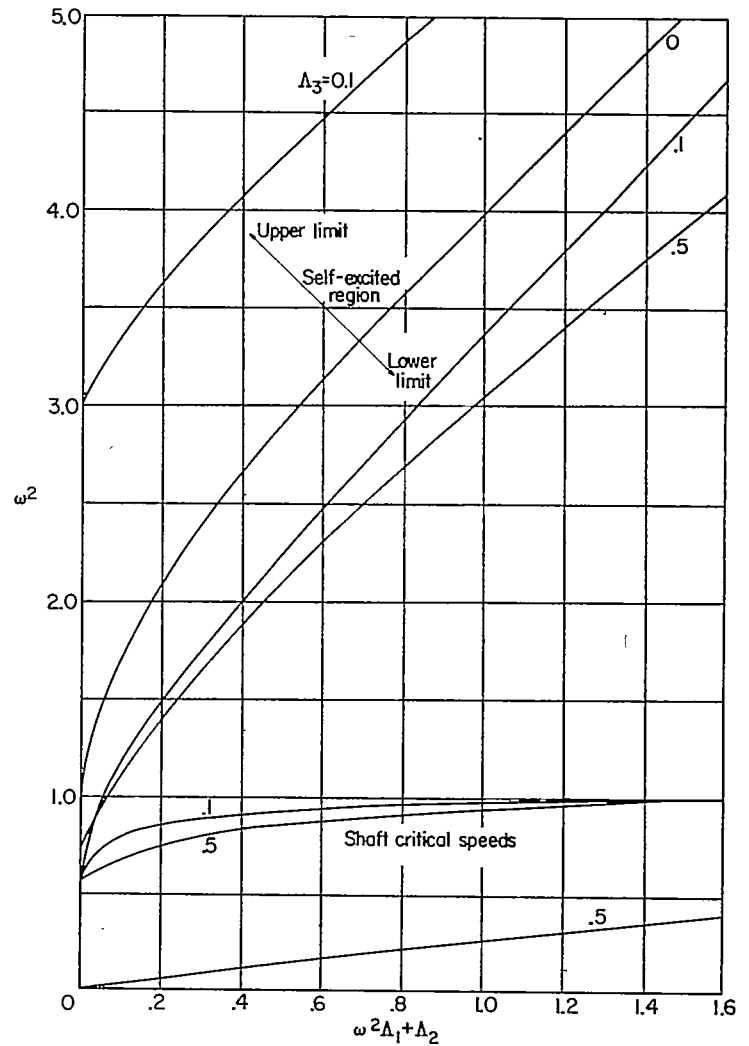

FIGURE I-6.—Stability chart for $s = 0$.

ranges. In the computations, it is preferable to choose values of ω_f and to solve the equations for the corresponding values of ω .

The explicit form for computation in the simplest case of isotropic supports, with damping in the pylon and in the hinges but not in the rotating shaft ($\lambda_a = 0$), is obtained from equation (32) rearranged as follows:

For the real equation

$$\begin{aligned} \omega^2 - 2B_R\omega + C_R &= 0 \\ \omega &= B_R \pm \sqrt{B_R^2 - C_R} \end{aligned} \quad (34)$$

where

$$B_R = \frac{\omega_f}{1 - \Delta_1} \left[1 + \frac{\lambda_f \lambda_\beta}{2 \left(-\omega_f^2 + \frac{K_f}{M} \right)} \right]$$

and

$$C_R = -\frac{\omega_f^2}{1 - \Delta_1} \left(-1 + \frac{\Delta_2}{\omega_f^2} - \frac{\Delta_3 \omega_f^2 + \lambda_f \lambda_\beta}{-\omega_f^2 + \frac{K_f}{M}} \right)$$

For the imaginary equation

$$\omega^2 - 2B_I\omega + C_I = 0 \quad (35)$$

where

$$B_I = \frac{1}{1 - \Delta_1} \left[\omega_f - \frac{\lambda_\beta}{2\lambda_f \omega_f} \left(-\omega_f^2 + \frac{K_f}{M} \right) \right]$$

and

$$C_I = -\frac{1}{1 - \Delta_1} \left[\frac{\lambda_\beta}{\lambda_f} \left(-\omega_f^2 + \frac{K_f}{M} \right) + \left(-\omega_f^2 + \Delta_2 \right) \right]$$

The real and imaginary equations for the most general case of equation (31) can be written, respectively, as follows:

$$\lambda_a^2 (1 - \Delta_1)^2 \omega^6 + [R_1 (1 - \Delta_1)^2 + \lambda_a^2 R_3] \omega^4 + (R_1 R_3 - I_1 I_3 + \lambda_a^2 R_2 - R_5) \omega^2 + R_1 R_2 - I_1 I_2 - R_4 + \Delta_3^2 \omega_f^2 = 0 \quad (36)$$

$$[I_1 (1 - \Delta_1)^2 + \lambda_a^2 I_3] \omega^4 + (R_1 I_3 + R_3 I_1 + \lambda_a^2 I_2 - I_6) \omega^2 + R_1 I_2 + R_2 I_1 - I_4 = 0 \quad (37)$$

where

$$R_1 = \frac{M_x M_y}{M^2} \left(-\omega_f^2 + \frac{K_x}{M_x} \right) \left(-\omega_f^2 + \frac{K_y}{M_y} \right) -$$

$$\omega_f^2 \left(\lambda_x \frac{M_x}{M} + \lambda_a \right) \left(\lambda_y \frac{M_y}{M} + \lambda_a \right)$$

$$I_1 = \frac{M_x}{M} \left(-\omega_f^2 + \frac{K_x}{M_x} \right) \omega_f \left(\lambda_y \frac{M_y}{M} + \lambda_a \right) + \frac{M_y}{M} \left(-\omega_f^2 + \frac{K_y}{M_y} \right) \omega_f \left(\lambda_x \frac{M_x}{M} + \lambda_a \right)$$

$$R_2 = (-\omega_f^2 + \Delta_2)^2 - \omega_f^2 \lambda_\beta^2$$

$$I_2 = 2(-\omega_f^2 + \Delta_2) \omega_f \lambda_\beta$$

$$R_3 = -2(1 - \Delta_1)(-\omega_f^2 + \Delta_2) - 4\omega_f^2 + \lambda_\beta^2$$

$$I_3 = -2(1 - \Delta_1) \omega_f \lambda_\beta + 4\omega_f \lambda_\beta$$

$$R_4 = 2\omega_f^4 \Delta_3 \left[\left(-\omega_f^2 + \frac{K_f}{M} \right) (-\omega_f^2 + \Delta_2) - \omega_f^2 (\lambda_f + \lambda_a) \lambda_\beta \right]$$

$$I_4 = 2\omega_f^4 \Delta_3 \left[\left(-\omega_f^2 + \frac{K_f}{M} \right) \omega_f \lambda_\beta + \omega_f (\lambda_f + \lambda_a) (-\omega_f^2 + \Delta_2) \right]$$

$$R_5 = 2\omega_f^4 \Delta_3 \left[-(1 - \Delta_1) \left(-\omega_f^2 + \frac{K_f}{M} \right) - \lambda_a \lambda_\beta \right]$$

$$I_5 = 2\omega_f^4 \Delta_3 \left[-(1 - \Delta_1) \omega_f (\lambda_f + \lambda_a) - 2\lambda_a \omega_f \right]$$

Examples of calculated cases with damping are shown in figures I-7 to I-9. The presence of small amounts of damping in both the pylon and the hinge degrees of freedom does not greatly change the predictions that would be made from

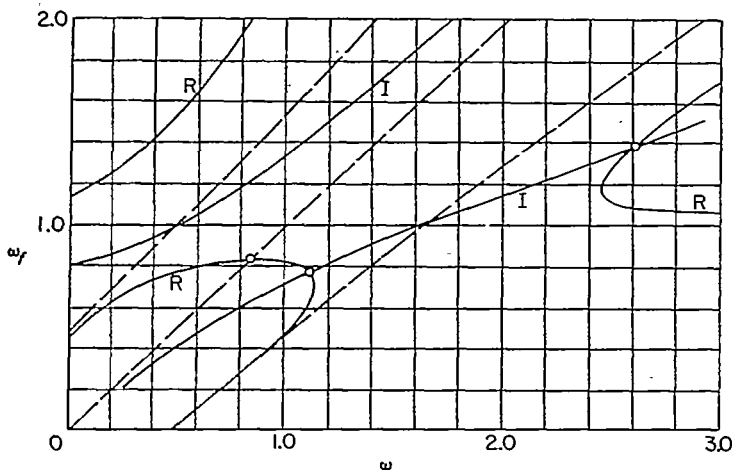

FIGURE I-7.—Plot of real and imaginary equations for a typical case. $s=1$; $\Delta_1=0.07$; $\Delta_2=0.22$; and $\Delta_3=0.198$.

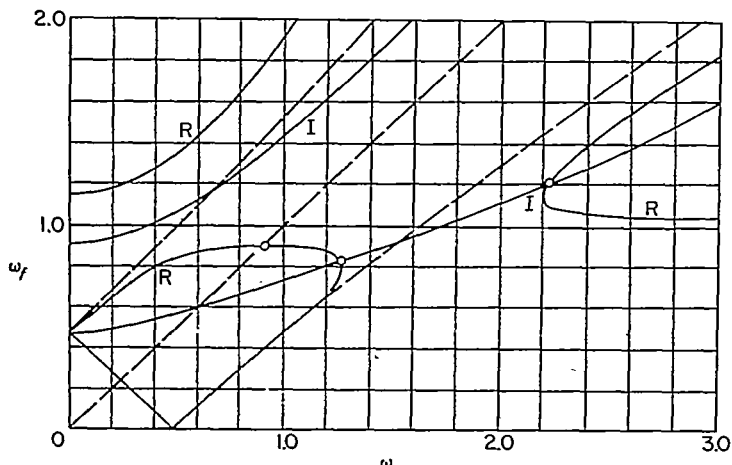

FIGURE I-8.—Plot of real and imaginary equations for case of $s=\infty$, $\Delta_1=0.07$, $\Delta_2=0.22$, and $\Delta_3=0.198$.

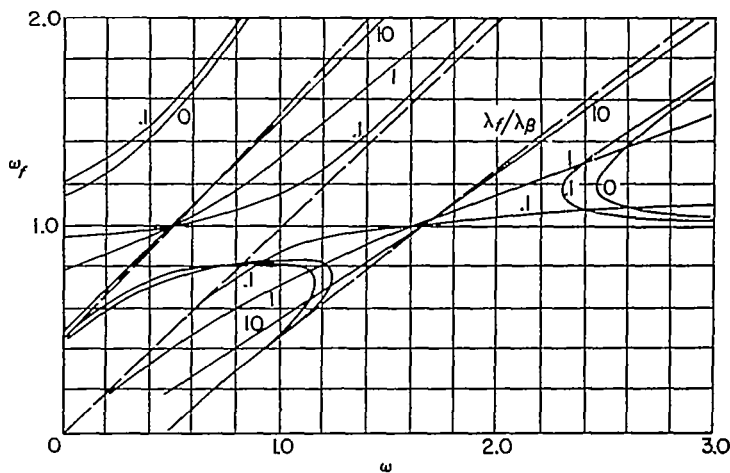

FIGURE I-9.—Effect of damping for case of $s=1$, $\Delta_1=0.07$, $\Delta_2=0.22$, and $\Delta_3=0.198$.

the equations with no damping. The plot of the real equation is practically the same as the plot obtained when damping is neglected. The intersections of the curves of the imaginary and the real equations with any reasonable value of λ_f/λ_β are near the points that would be considered the limits of the unstable range if damping were neglected. Increasing the amount of damping decreases the gap between the limits of stability until the unstable range is finally eliminated. An approximate solution for the amount of damping required to eliminate the self-excited instability is obtained by requiring that the damping be at least large enough to make the curve of the real equation pass through the point where $\omega_f=1$ and ω is the value given by the equation

$$1 = \omega - \sqrt{\omega^2 \Delta_1 + \Delta_2}$$

The values required in the case of $s = \infty$ have been computed and plotted in figure I-10. The elimination of self-excited vibration by damping thus looks promising and merits further study with reference to specific application.

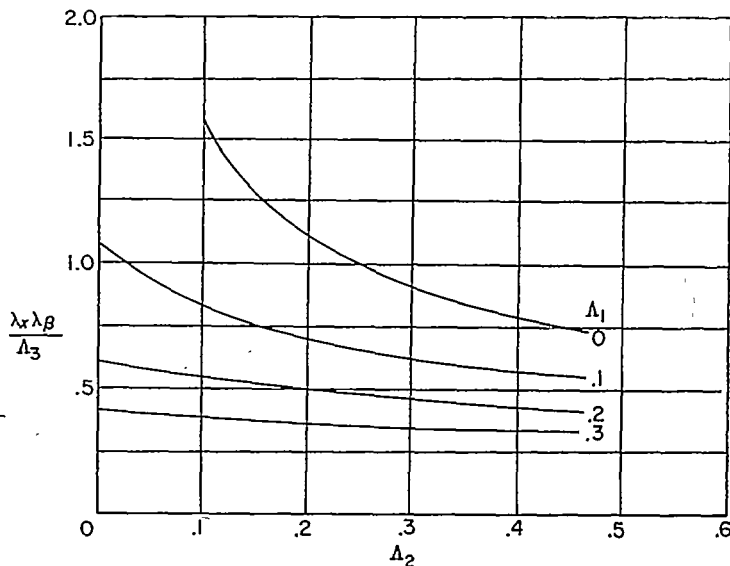

FIGURE I-10.—Damping required to eliminate self-excited oscillation for $s=\infty$.

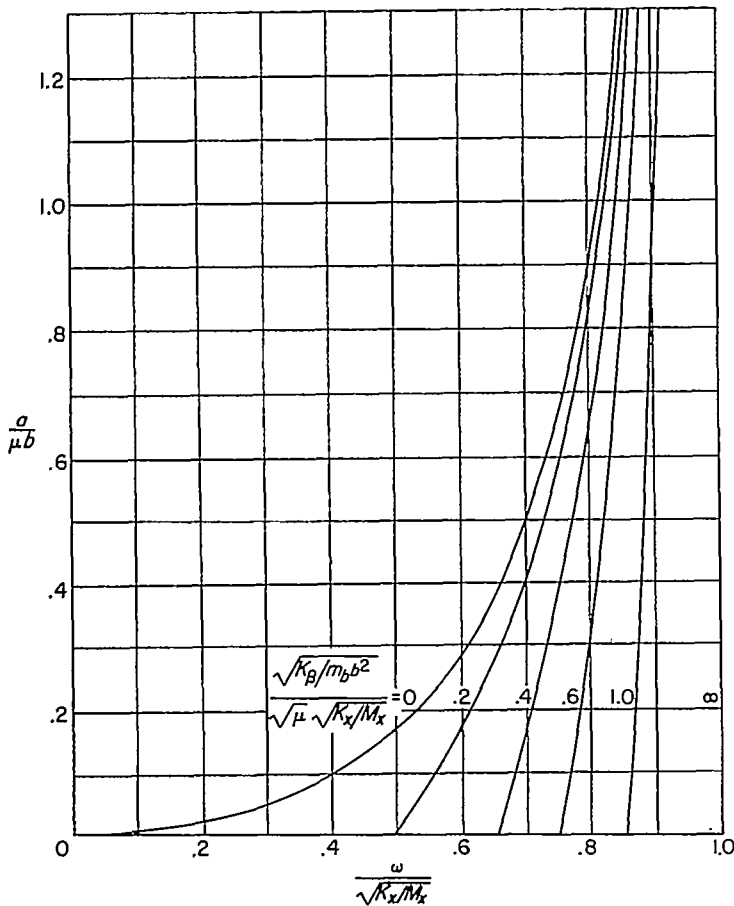

FIGURE I-11.—Shaft critical speeds for $s=1$.

LIMITATIONS AND FURTHER DEVELOPMENTS OF THE THEORY

POLAR SYMMETRY

An important idea in the rotor vibration theory is the concept of polar symmetry. This concept implies the absence of a preferred direction in the plane of the rotor. A rotor of three or more equal blades has polar symmetry. A rotor of two blades or one with unequal centering springs does not have polar symmetry. A pylon for which $K_x=K_y$, $B_x=B_y$, and $m_x=m_y$ has polar symmetry. The possibility of solving the rotor vibration problem in terms of exponential or trigonometric functions depends upon the existence of polar symmetry in the rotating parts or in the nonrotating parts or in both. The general case of no polar symmetry would lead to Mathieu functions or something similar.

TWO BLADES

A brief comparison between the two-blade and the general case is presented herein. Polar symmetry of the pylon is assumed. The shaft critical speed is obtained by substituting $\omega_a=0$ in the characteristic equation as expressed in a rotating coordinate system. For one or two blades, the equation obtained is

$$\left[\left(-\omega^2 + \frac{K_f}{\lambda^2} \right) \left(\omega^2 \frac{a}{\lambda^2} + \frac{K_\beta}{\lambda^2} \right) - \mu \omega^4 \right] \left(-\omega^2 + \frac{K_f}{\lambda^2} \right) = 0 \quad (38)$$

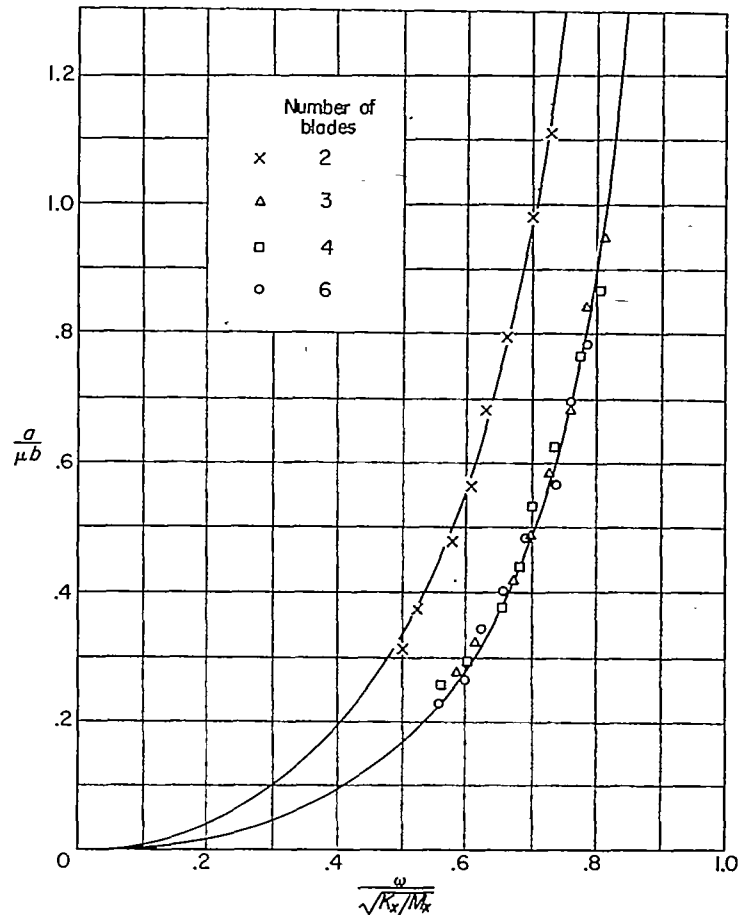

FIGURE I-12.—Experimental critical speeds on small models.

The first bracketed factor gives the beginning of a self-excited range and the second factor gives the end of the range.

Equation (38) can be compared with the following equation for the shaft critical speed of a rotor with three or more equal blades and polar symmetry:

$$\left(-\omega^2 + \frac{K_f}{M} \right) \left(\omega^2 \frac{a}{b} + \frac{K_\beta}{m_b b^2} \right) - \frac{\mu}{2} \omega^4 = 0 \quad (39)$$

A useful chart based on equation (39) is given in figure I-11; some experimental results of tests of a simple model are given in figure I-12. These tests demonstrate the essential difference between the two-blade and the general case.

LANGLEY AERONAUTICAL LABORATORY,
NATIONAL ADVISORY COMMITTEE FOR AERONAUTICS,
LANGLEY FIELD, VA., August 24, 1956.

REFERENCES

1. Den Hartog, J. P.: Mechanical Vibrations. McGraw-Hill Book Co., Inc., 1934, pp. 237-328.
2. Lamb, Horace: Higher Mechanics. Second ed., Cambridge Univ. Press, 1929, pp. 200-201, 241-255.
3. Lamb, Horace: Hydrodynamics. Sixth ed., Cambridge Univ. Press, 1932, pp. 307-319, 562-571.
4. Prewitt, R. H., and Wagner, R. A.: Frequency and Vibration Problems of Rotors. Jour. Aero. Sci., vol. 7, no. 10. April 1940

CHAPTER II

THEORY OF MECHANICAL OSCILLATIONS OF ROTORS WITH TWO HINGED BLADES

By ARNOLD M. FEINGOLD

SUMMARY

The mechanical stability of a rotor having two vertically hinged blades mounted upon symmetrical supports, that is, of equal stiffness and mass in all horizontal directions, is investigated and reported herein. The frequency equation is derived and shows the existence, in general, of two ranges of rotational speeds at which instability occurs. The lower region of instability is bounded by two shaft critical speeds. At rotor speeds within this region, self-excited divergence of the rotor takes place analogous to the instability exhibited by a rotating shaft that is elliptical in cross section. Within the second instability range, the rotor system undergoes self-excited oscillations. Charts are presented giving the boundary points of both instability regions for a large variety of values of the physical parameters. The effect of damping is also included in the analysis.

INTRODUCTION

In chapter I, Coleman gives an analytical study of the mechanical stability of a rotor having three or more vertically hinged blades, mounted on flexible supports. It was shown that, in addition to the usual shaft critical speeds, self-excited vibrations occurred over a range of rotational speeds. Experiments with rotary-wing aircraft have confirmed the soundness of the analysis.

The present chapter is an investigation of the stability of the two-blade rotor mounted on symmetrical supports. As will be shown later, the results differ from those for a three-blade rotor. The reason for the different behavior lies in the inherent asymmetry of a rotor with only two blades. Motion of the center of mass of the blades of a two-blade rotor with respect to the rotor hub, due to small hinge deflections of the blades, must be normal to the line of the blades. This restraint, which does not appear in a rotor of three or more blades, results in the rotor system having different dynamic properties along and normal to the line of the blades. Therefore, with supports that have equal stiffness and mass in all directions attached to a two-blade rotor, two principal vibration axes of the rotor hub can still be distinguished. No preferred vibration axes can be distinguished for a three-blade rotor mounted on symmetrical supports. This distinction shows up physically in the shape of the vibration modes. Whereas a three-blade rotor whirls in a circle, a two blade rotor whirls in an ellipse, of which the principal axes are along and normal to the line of the rotor blades.

A two-blade rotor can be expected to show, in addition to some features of a three-blade rotor, some of the characteristics of a rotating shaft that is elliptical in cross section.

Such a shaft, mounted on symmetrical bearings, is known to have two critical speeds, which correspond to each of the two principal stiffnesses. (See, for example, ref. 1.) For all rotational speeds between the critical speeds, the shaft is unstable and diverges. It will be shown that an exactly similar phenomenon exists for a two-blade rotor. The existence of this region of instability for a two-blade rotor is predicted in chapter I, in which the formula for the shaft critical speeds bounding this instability range is given. In addition to this region of instability, a second range of instability analogous to that exhibited by a three-blade rotor is also present.

Only the case of symmetrical supports is analyzed in the present report. In the case of asymmetric supports, the equations of motion are linear differential equations that are difficult to solve because the coefficients vary periodically with the time (Mathieu type). Similar equations are obtained in the problem of a rotating elliptical shaft mounted on asymmetric bearings. (See ref. 1.)

SYMBOLS

<i>a</i>	radial position of vertical hinge
<i>b</i>	distance from vertical hinge to center of mass of blade
<i>B</i>	damping force per unit velocity of rotor-hub displacement
<i>B_β</i>	damping force per unit angular velocity of blade displacement about hinge
<i>D</i>	time-derivative operator, <i>d/dt</i>
<i>F</i>	dissipation function
<i>I</i>	moment of inertia of blade about hinge,
	$m_b b^2 \left(1 + \frac{r^2}{b^2}\right)$
<i>K</i>	spring constant of rotor-hub displacement
<i>K_β</i>	spring constant of blade self-centering spring
<i>m</i>	effective mass of pylon
<i>m_b</i>	effective mass of rotor blade
<i>M</i>	total effective mass of blades and pylon, <i>m + 2m_b</i>
<i>r</i>	radius of gyration of blade about its center of mass
<i>s</i>	arbitrary parameter
<i>t</i>	time
<i>T</i>	kinetic energy
<i>T₁, T₂</i>	kinetic energies of rotor blades
<i>T_s</i>	kinetic energy of rotor hub
<i>V</i>	potential energy
<i>x, y</i>	displacements of rotor hub in rotating coordinate system

- X_a, Y_a rotating coordinate axes
 X_f, Y_f fixed coordinate axes
 x_0, y_0 values of x and y when $t=0$
 x_1, y_1 displacement of first rotor blade in fixed coordinate system
 x_2, y_2 displacement of second rotor blade in fixed coordinate system
 β_1, β_2 angular displacements of blades about their hinges

$$\theta_0 = \frac{b(\beta_1 + \beta_2)}{2}$$

$$\theta_1 = \frac{b(\beta_1 - \beta_2)}{2}$$

θ_{1_0} value of θ_1 when $t=0$

$$\lambda = \frac{B}{M\omega_r}$$

$$\lambda_\beta = \frac{B_\beta}{I\omega_r}$$

$$\Lambda_1 = \frac{a}{b \left(1 + \frac{r^2}{b^2}\right)}$$

$$\Lambda_2 = \frac{K_\beta}{I\omega_r^2}$$

$$\Lambda_3 = \frac{m_b}{M \left(1 + \frac{r^2}{b^2}\right)}$$

ω angular velocity of rotor (the dimensionless ratio ω/ω_r is called ω in applications)

ω_a natural frequency of rotor system observed in rotating coordinate system (used in nondimensional form in applications)

ω_r natural frequency of rotor system in fixed coordinate system (nondimensional in applications)

ω_r reference frequency, $\sqrt{K/M}$

MATHEMATICAL ANALYSIS

Four degrees of freedom of the system are considered—horizontal deflection of the rotor hub in the x - and y -directions, and hinge deflections β_1 and β_2 of the blades in the horizontal plane of the rotor hub. The rotor is assumed to rotate at a constant velocity ω .

Deflection of the rotor hub may be due either to the bending of a flexible pylon or to a rocking of the rotor craft upon its landing gear. Ground-resonance vibrations usually involve landing-gear flexibility. The mathematical treatment is the same in both cases, but the values of several of the physical parameters will depend upon which mode is being investigated. In this chapter, the terms "rotor supports" and "pylon" will be used interchangeably to denote the nonrotating structure coupled with the rotor blades.

The mathematical treatment herein differs from that in chapter I, in which are used the complex notation and the notion of "whirling speeds," that is, directional frequencies

resulting from the use of complex numbers. Although the method of chapter I is valuable for systems, such as the three-blade rotor on symmetrical supports, which have circular modes of vibration, it offers little advantage for the present problem, in which the rotor performs elliptical motion. Rectangular coordinates accordingly are used in the present report and frequencies are used instead of whirling speeds. In comparing the results of the present report with those of chapter I, care should be taken to distinguish between frequencies and whirling speeds. Whirling speeds have directional significance; whereas frequencies are essentially positive quantities and do not give any immediate information concerning the direction of whirl of the vibration.

The equations of motion are set up in a coordinate system rotating at the velocity ω . Let the deflection of the rotor hub be represented by x and y in rotating coordinates. (See fig. II-1 in which the intersection of the coordinate axes represents the undisturbed position of the rotor hub.) The disturbed positions of the two blades in fixed coordinates are

$$x_1 = (x + a + b \cos \beta_1) \cos \omega t - (y + b \sin \beta_1) \sin \omega t$$

$$y_1 = (y + b \sin \beta_1) \cos \omega t + (x + a + b \cos \beta_1) \sin \omega t$$

and

$$x_2 = (x - a - b \cos \beta_2) \cos \omega t - (y - b \sin \beta_2) \sin \omega t$$

$$y_2 = (y - b \sin \beta_2) \cos \omega t + (x - a - b \cos \beta_2) \sin \omega t$$

The kinetic energies of the two rotor blades are

$$T_1 = \frac{1}{2} m_b [\dot{x}_1^2 + \dot{y}_1^2 + r^2(\omega + \dot{\beta}_1)^2]$$

and

$$T_2 = \frac{1}{2} m_b [\dot{x}_2^2 + \dot{y}_2^2 + r^2(\omega + \dot{\beta}_2)^2]$$

The kinetic energy of the pylon is

$$T_p = \frac{1}{2} m [\dot{x}^2 + \dot{y}^2 + \omega^2(x^2 + y^2) - 2\omega(\dot{x}y - x\dot{y})]$$

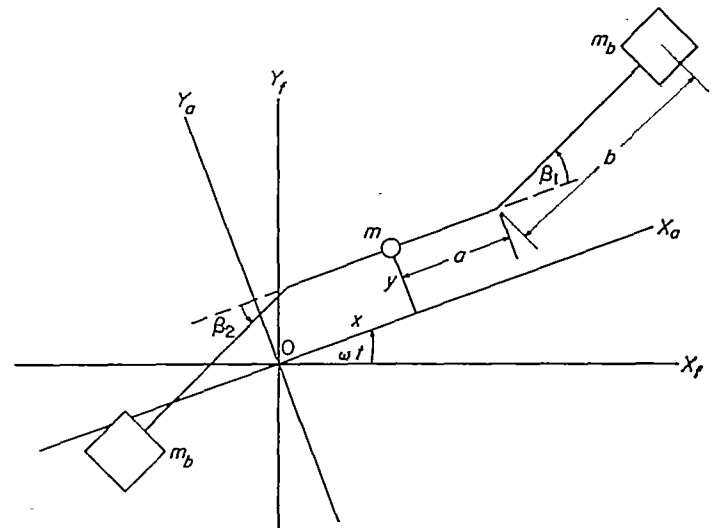

FIGURE II-1.—Simplified mechanical system representing rotor.

Because only small displacements from the equilibrium position are considered, the trigonometric expressions containing β_1 and β_2 may be expanded as power series and only the terms that lead to quadratic terms in the energy expressions need be retained. Thus

$$\sin \beta_1 = \beta_1$$

$$\cos \beta_1 = 1 - \frac{\beta_1^2}{2}$$

and

$$\sin \beta_2 = \beta_2$$

$$\cos \beta_2 = 1 - \frac{\beta_2^2}{2}$$

New variables introduced to replace β_1 and β_2 are

$$\theta_0 = \frac{b}{2} (\beta_1 + \beta_2)$$

$$\theta_1 = \frac{b}{2} (\beta_1 - \beta_2)$$

where θ_1 represents the shift, due to hinge motion, of the center of mass of the two blades with respect to the rotor hub. The introduction of θ_0 and θ_1 results in a partial decoupling of the equations of motion.

The total kinetic energy of the system is

$$T = T_1 + T_2 + T_3$$

Only the quadratic terms will be retained in the kinetic-energy expression, because the terms of lower degree vanish in the Lagrange equations of motion. Then

$$T = \frac{1}{2} M [\dot{x}^2 + \dot{y}^2 + \omega^2 (x^2 + y^2) - 2\omega (\dot{x}y - x\dot{y})] + m_b \left[2\dot{\theta}_1^2 + 2\omega^2 \theta_1 + 2\omega \dot{\theta}_1 - 2\omega \dot{x} \theta_1 + \left(1 + \frac{r^2}{b^2}\right) (\dot{\theta}_0^2 + \dot{\theta}_1^2) - \omega^2 \frac{a}{b} (\theta_0^2 + \theta_1^2) \right]$$

The potential energy of the system is

$$V = \frac{1}{2} K (x^2 + y^2) + \frac{K_\beta}{2} (\beta_1^2 + \beta_2^2) \\ = \frac{1}{2} K (x^2 + y^2) + \frac{K_\beta}{b^2} (\theta_0^2 + \theta_1^2)$$

Two types of damping of the rotor system are assumed to exist: (1) damping in the rotor supports, which is propor-

tional to velocity displacements of the rotor hub in a fixed coordinate system, and (2) damping in the blade hinges. The dissipation function F then becomes

$$F = \frac{1}{2} B [\dot{x}^2 + \dot{y}^2 + \omega^2 (x^2 + y^2) - 2\omega (\dot{x}y - x\dot{y})] + \frac{B_\beta}{b^2} (\dot{\theta}_0^2 + \dot{\theta}_1^2)$$

where B is the damping force per unit velocity of rotor-hub displacement and B_β is the damping force per unit velocity of a rotor-blade displacement about the blade hinge.

The Lagrange equation of motion for the variable x is

$$\frac{d}{dt} \left(\frac{\partial T}{\partial \dot{x}} \right) - \frac{\partial T}{\partial x} + \frac{\partial V}{\partial x} + \frac{\partial F}{\partial \dot{x}} = 0$$

The use of similar expressions for y , θ_0 , and θ_1 lead to the following equations of motion:

$$\left(D^2 - \omega^2 + \frac{B}{M} D + \frac{K}{M} \right) x - \frac{4m_b}{M} \omega D \theta_1 - \left(2\omega D + \frac{B}{M} \omega \right) y = 0 \quad (1)$$

$$2\omega D x + \left[\left(1 + \frac{r^2}{b^2} \right) D^2 + \frac{B_\beta}{m_b b^2} D + \frac{K_\beta}{m_b b^2} + \frac{a}{b} \omega^2 \right] \theta_1 + (D^2 - \omega^2) y = 0 \quad (2)$$

$$\left(2\omega D + \frac{B}{M} \omega \right) x + \frac{2m_b}{M} (D^2 - \omega^2) \theta_1 + \left(D^2 - \omega^2 + \frac{B}{M} D + \frac{K}{M} \right) y = 0 \quad (3)$$

$$\left[\left(1 + \frac{r^2}{b^2} \right) D^2 + \frac{B_\beta}{m_b b^2} D + \omega^2 \frac{a}{b} + \frac{K_\beta}{m_b b^2} \right] \theta_0 = 0 \quad (4)$$

where

$$D = \frac{d}{dt} \quad D^2 = \frac{d^2}{dt^2}$$

Equation (4) can be solved independently of the others because it is an equation in only one variable θ_0 . Equation (4), which also was obtained in the study of the three-blade rotor (chapter I), represents blade motion with the blades moving in phase, uncoupled with pylon motion. Motion in this mode is damped and does not lead to instability.

Assuming solutions of the form

$$\left. \begin{aligned} x &= x_0 e^{i\omega_a t} \\ y &= y_0 e^{i\omega_a t} \\ \theta_1 &= \theta_1 e^{i\omega_a t} \end{aligned} \right\} \quad (5)$$

and substituting these solutions in equations (1) to (3) gives the characteristic or frequency equation

$$\begin{vmatrix} -\omega_a^2 - \omega^2 + i\lambda\omega_a + 1 & 4\Lambda_3\omega\omega_a & 2\omega\omega_a - i\lambda\omega \\ 2\omega\omega_a & -\omega_a^2 + i\lambda\beta\omega_a + \Lambda_2 + \Lambda_1\omega^2 & -\omega_a^2 - \omega^2 \\ 2\omega\omega_a - i\lambda\omega & -2\Lambda_3(\omega_a^2 + \omega^2) & -\omega_a^2 - \omega^2 + i\lambda\omega_a + 1 \end{vmatrix} = 0 \quad (6)$$

where the nondimensional parameters

$$\Lambda_1 = \frac{a}{b \left(1 + \frac{r^2}{b^2} \right)}$$

$$\Lambda_2 = \frac{K_\beta}{I\omega_r^2}$$

$$\Lambda_3 = \frac{m_b}{M \left(1 + \frac{r^2}{b^2} \right)}$$

$$\lambda = \frac{B}{M\omega_r}$$

$$\lambda_\beta = \frac{B_\beta}{I\omega_r}$$

have been introduced, and the rotational velocity ω and the frequency ω_a have also been made nondimensional by using $\omega_r = \sqrt{K/M}$ as reference frequency.

The frequency ω_a generally is a complex number, of which the real part is the frequency of the vibration and the imaginary part determines the rate of damping of the vibration. If the imaginary part of ω_a is negative, the vibration increases in amplitude with time and the rotor is unstable.

DISCUSSION OF FREQUENCY EQUATION

CASE OF ZERO DAMPING

If the damping parameters λ and λ_β are neglected, the frequency equation (6) may be expanded to

$$2\Delta_3(\omega^2 + \omega_a^2 - 1) + [4\omega^2\omega_a^2 - (\omega^2 + \omega_a^2 - 1)^2][-2\Delta_3(\omega^2 + \omega_a^2 + 1) + \omega_a^2 - \Delta_2 - \Delta_1\omega^2] = 0 \quad (7)$$

where ω_a is the natural frequency of the rotor system in a coordinate system rotating with the rotor. (Although equation (7) is a cubic equation in both ω^2 and ω_a^2 , rectangular hyperbolas of the form $\omega_a^2 = \omega^2 + s$, where s is an arbitrary parameter, intersect equation (7) at only two values of ω^2 . For purposes of computation, therefore, equation (7) can be reduced to a quadratic equation in ω^2 by replacing ω_a^2 with $\omega^2 + s$.)

The solutions for zero damping (eq. (5)) represent motion of the pylon in an ellipse expressed relative to the rotating coordinate axes. In fixed coordinates, the pylon would move in an ellipse precessing at the velocity ω . This motion can be resolved into simultaneous circular motion at the two frequencies $|\omega + \omega_a|$ and $|\omega - \omega_a|$, in which the vertical lines indicate that the quantity inside is to be considered positive. If the pylon is subjected to a harmonic force in the fixed coordinate system of frequency ω_f , resonance will occur at each of the frequencies

$$\omega_f = |\omega \pm \omega_a|$$

The frequency ω_f will be referred to as the natural frequency of the rotor system in fixed coordinates.

The graph of the frequency equation (7) for a typical set of values of the parameters is given in figure II-2 in rotating coordinates and in figure II-3 in fixed coordinates. For zero coupling between the blades and rotor hub—that is, when Δ_3 equals zero—equation (7) factors into straight lines and a hyperbola, which are shown as long-dash lines in figures II-2 and II-3. The straight lines represent hub motion and the hyperbola represents blade motion. A small increase in Δ_3 results in a breaking away of the curves at their intersections to form two self-excited regions. It is interesting to compare figure II-3 with figure II-4, which is the graph of the natural frequencies of a three-blade rotor having the same values of Δ_1 , Δ_2 , and Δ_3 .

The shaft critical speeds, or natural frequencies that would be in resonance with an unbalance in the rotor system, are found by putting $\omega_a = 0$ in equation (7). Figure II-2 shows two such speeds, at points A and B (shown also in fig. II-3), that bound a region in which ω_a is a pure imaginary number. If ω_a is a complex root of the characteristic

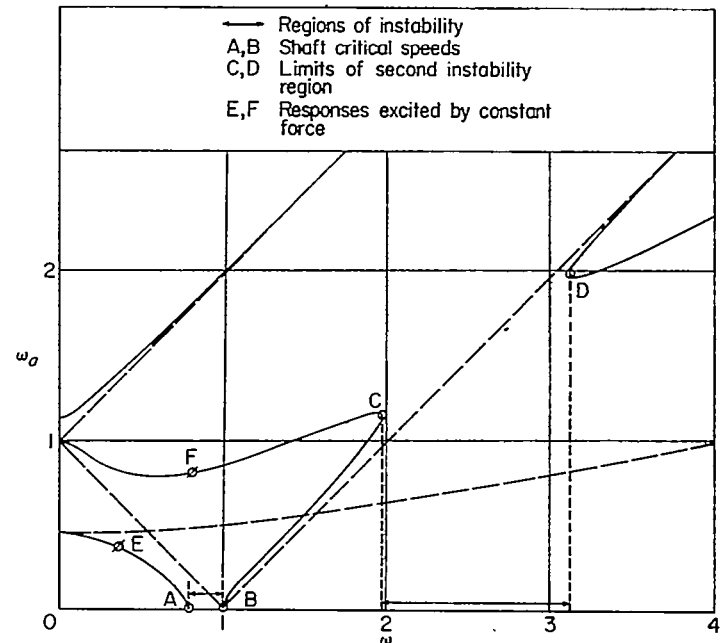

FIGURE II-2.—Natural frequencies of a two-blade rotor in rotating coordinates for case of $\Delta_1=0.05$, $\Delta_2=0.20$, and $\Delta_3=0.10$.

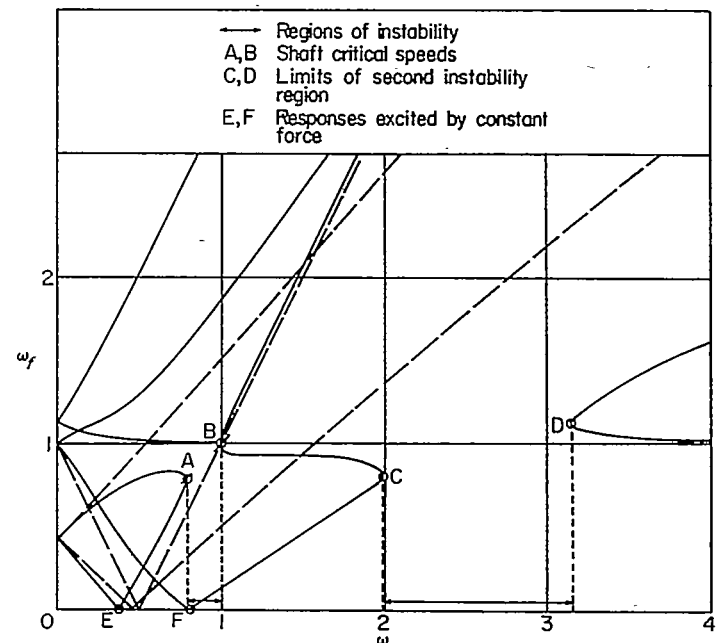

FIGURE II-3.—Natural frequencies of a two-blade rotor in fixed coordinates for case of $\Delta_1=0.05$, $\Delta_2=0.20$, and $\Delta_3=0.10$.

equation, the complex conjugate of ω_a will also be a root and one of the two roots will have a negative imaginary part implying instability. The rotor system will thus be unstable for all rotational speeds between the two shaft critical speeds. Because ω_a is a pure imaginary number in this region, the frequency of the resultant self-excited vibration is zero in a rotating coordinate system—similar to the shaft critical speeds—and will appear as a self-excited divergence of the rotor.

The equation of the shaft critical speeds is

$$[(1 - \omega^2)(\Delta_2 + \Delta_1\omega^2) - 2\Delta_3\omega^4](1 - \omega^2) = 0 \quad (8)$$

The first factor gives the lower shaft critical speed. The

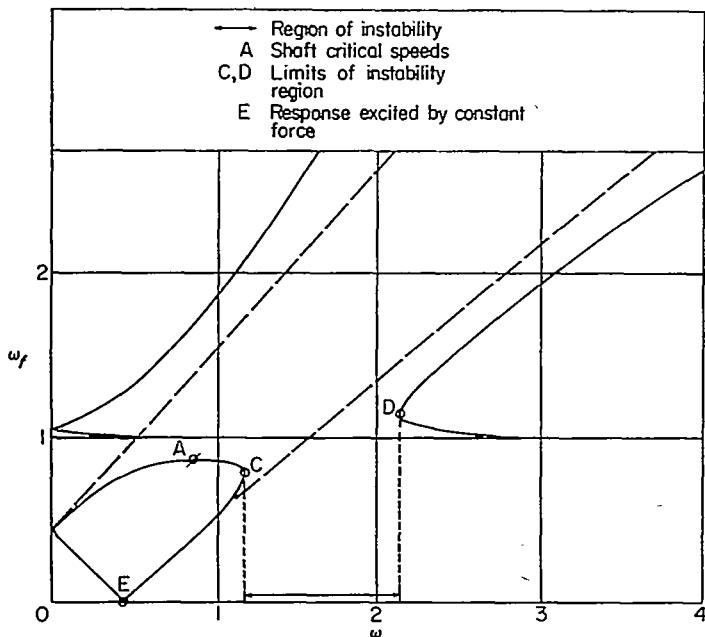

FIGURE II-4.—Natural frequencies of a three-blade rotor in fixed coordinates for case of $\Delta_1=0.05$, $\Delta_2=0.20$, and $\Delta_3=0.10$.

second factor, which depends on only the reference frequency, marks the end of the range of instability and is the second shaft critical speed. Formula (8) and an experimental verification of it are given in chapter I. A convenient graph of equation (8) is given in figure II-5. It will be noticed that it is impossible to remove the two shaft critical speeds or the instability region between them by any possible change of the parameters Δ_1 , Δ_2 , or Δ_3 ; that is, without the introduction of damping, self-excited vibrations will always occur below the rotational speed ω_r .

Instability also occurs in a range of rotational speeds greater than ω_r . This range is shown in figures II-2 and II-3 as the region bounded by the points C and D and is similar in origin to the self-excited region exhibited by the three-blade rotor. In this region, the roots of the frequency equation are complex and self-excited vibrations will take place. Unlike the three-blade rotor, however, the rotor hub will be seen from a stationary position to be simultaneously executing self-excited vibrations at two different frequencies. Physically, of course, the rotor is moving in an ellipse at the frequency ω_a while precessing at the velocity ω .

A chart showing the lower and upper limits of this instability region for a wide choice of values for the parameters, Δ_1 , Δ_2 , and Δ_3 is given in figure II-6. The chart is used by drawing a straight line that represents the function $(1-4\Delta_3)\omega^2$ plotted against $\Delta_1\omega^2+\Delta_2$. The intersections of this straight line with the proper Δ_3 -curves give the desired values of ω . The short-dash line on the chart illustrates the method for the parameters of figure II-2.

The position of the instability region is very sensitive to the values of Δ_3 . (See fig. II-7.) As Δ_3 increases, the region of instability occurs at greater rotational speeds and moves to infinity for $\Delta_3=\frac{1}{4}(1-\Delta_1)$. For values of Δ_3

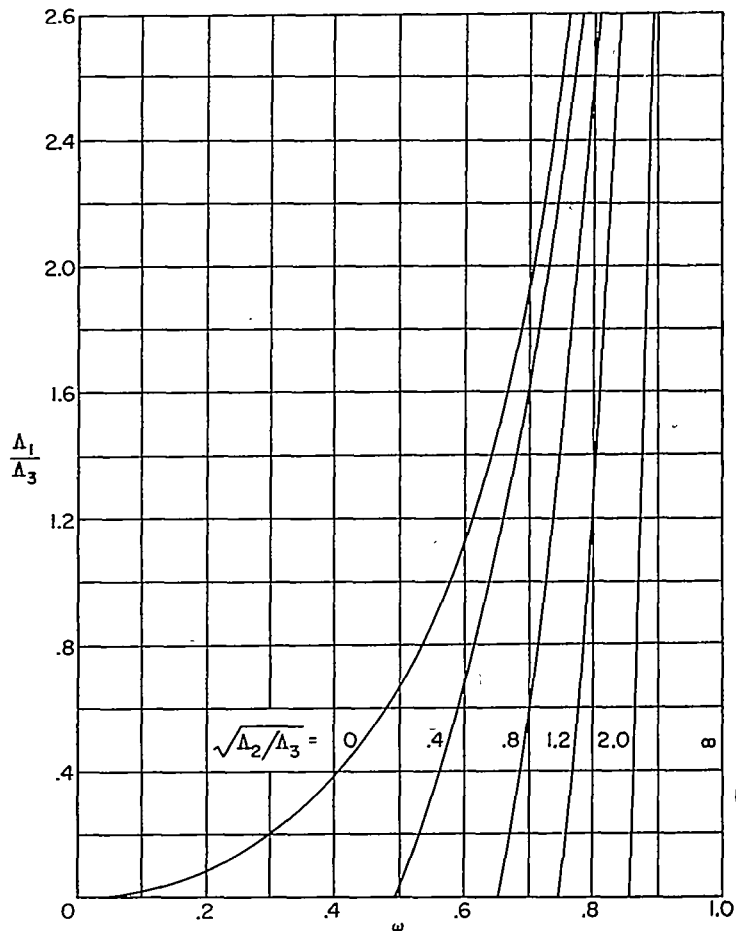

FIGURE II-5.—Shaft critical speeds.

greater than $\frac{1}{4}(1-\Delta_1)$ —that is, when the total effective mass of the rotor blades is greater than the effective mass of the rotor supports—the self-excited region does not appear.

At certain rotational speeds, $\omega_f=0$. At such speeds resonance may be excited by a steady force, constant in direction, acting on the pylon or blades—for example, gravity acting on a tilted rotor. The two-blade rotor has two such speeds, shown as points E and F in figures II-2 and II-3. The mathematical condition for such points is that $\omega_f=0$ or $\omega_a^2=\omega^2$ in equation (7). The equation giving the rotational speeds at which this condition may occur is

$$(\Delta_1\omega^2+\Delta_2)(4\omega^2-1)-\omega^2[\omega^2(4-16\Delta_3)-1]=0 \quad (9)$$

Equation (9) is plotted in figure II-8, which is used similarly to figure II-6. If $\Delta_2=0$, then point E occurs at $\omega=0$. If $\Delta_3 \geq \frac{1}{4}(1-\Delta_1)$, as pointed out in reference 2, then point F occurs at $\omega=\infty$.

EFFECT OF DAMPING

The effect of damping will be determined in the same manner as for the three-blade rotor in chapter I. When the damping parameters λ and λ_β are retained, equation (6) in expanded form can be separated into powers of ω_a having real and imaginary coefficients. The terms of equation (6) with

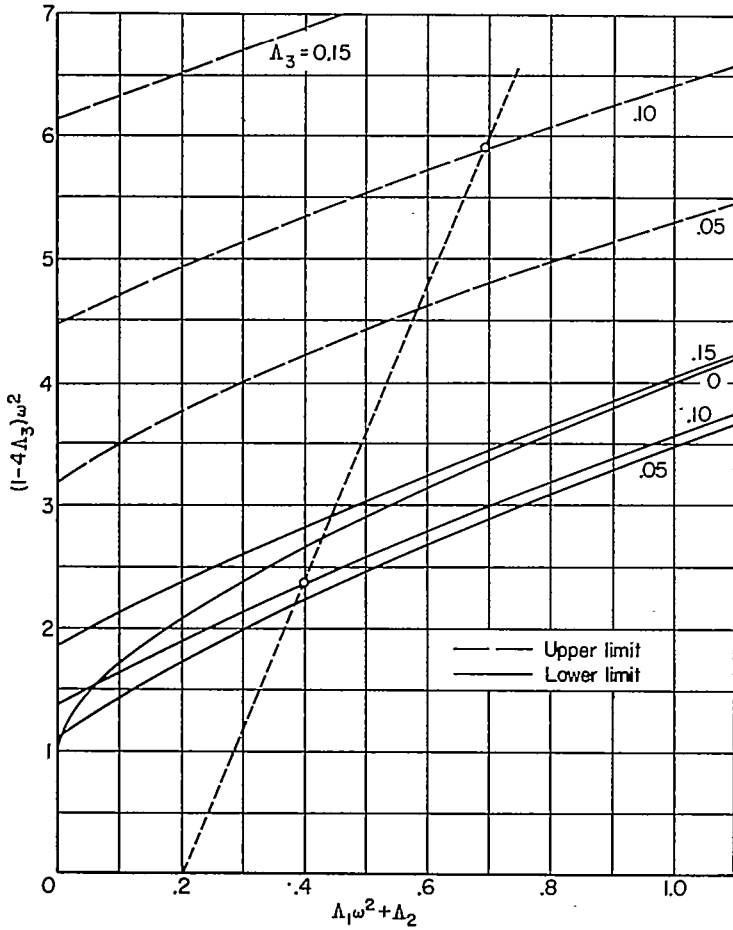

FIGURE II-6.—Stability chart for second instability region.

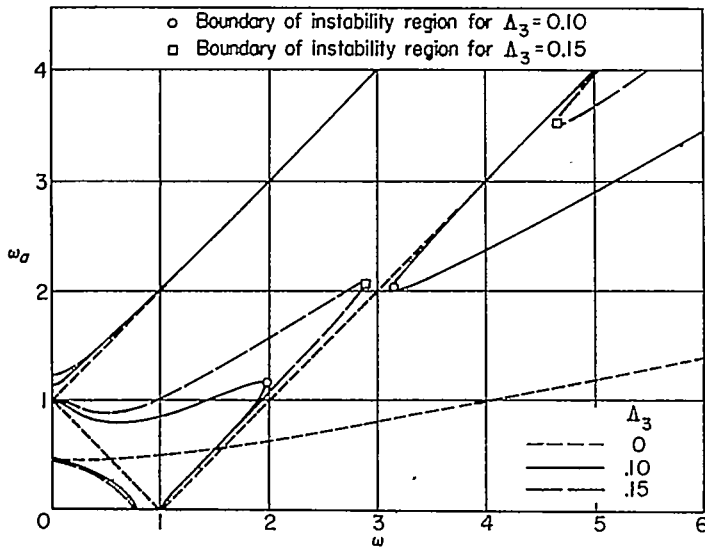

FIGURE II-7.—Effect of coupling parameter Δ_3 for case of $\Delta_1=0.05$ and $\Delta_2=0.20$.

real coefficients are

$$2\Delta_3(\omega^2 + \omega_a^2 - 1) + [4\omega^2\omega_a^2 - (\omega^2 + \omega_a^2 - 1)^2] [-2\Delta_3(\omega^2 + \omega_a^2 + 1) + \omega_a^2 - \Delta_2 - \Delta_1\omega^2] + \lambda^2(-\omega_a^2 + \Delta_2 + \Delta_1\omega^2)(\omega^2 - \omega_a^2) - 2\lambda\lambda_\beta\omega_a^2(\omega^2 - \omega_a^2 + 1) \quad (10)$$

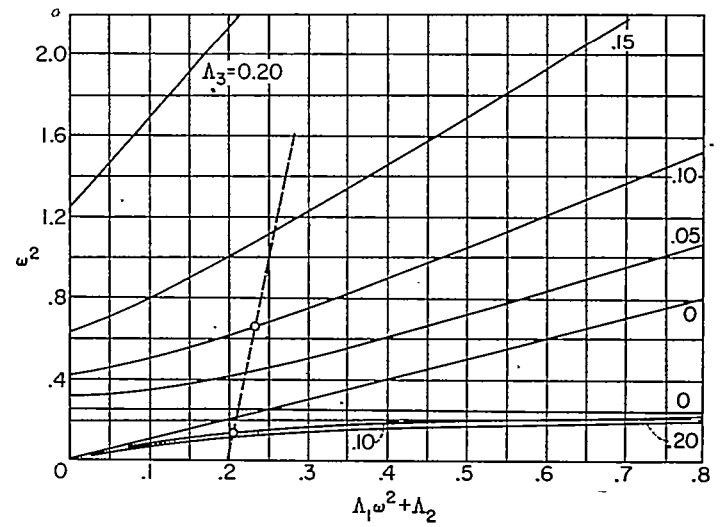

FIGURE II-8.—Rotational speeds at which vibration could be excited by steady force.

The terms with imaginary coefficients are

$$i\lambda_\beta\omega_a \left\{ 2\frac{\lambda}{\lambda_\beta} [(\omega^2 - \omega_a^2 + 1)(\Delta_1\omega^2 + \Delta_2 - \omega_a^2) + \Delta_3(3\omega^4 - 2\omega^2\omega_a^2 - \omega_a^4)] + \omega^4 + \omega_a^4 + 1 - 2\omega^2\omega_a^2 - 2\omega_a^2 - 2\omega^2 - \lambda^2(\omega_a^2 - \omega^2) \right\} \quad (11)$$

At a boundary between stability and instability, ω_a is real. Such points are the intersections of the equations formed by setting expressions (10) and (11) separately equal to zero and plotting them on the same coordinate axes. Figure II-9 shows a calculated case of damping. The imaginary equation is plotted for several values of the ratio of the damping parameters λ/λ_β , with λ^2 assumed to be negligible. It is seen that, for large values of λ/λ_β , the boundaries of the higher range of instability are not far different from the boundaries found by neglecting damping. Small values of λ/λ_β —that is, when most of the damping is concentrated in the blade

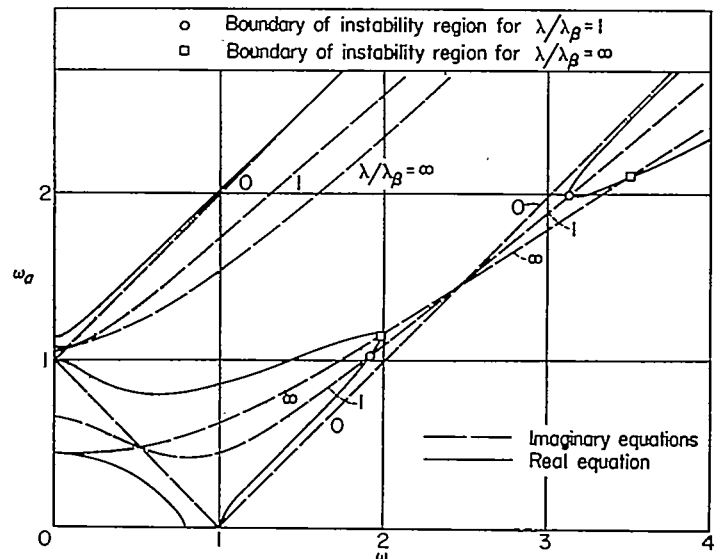

FIGURE II-9.—Plot of real and imaginary equations for case of $\Delta_1=0.05$, $\Delta_2=0.20$, $\Delta_3=0.10$, and $\lambda\lambda_\beta \approx 0$.

hinges—lead to a beginning of the instability at lower rotational speeds.

For small amounts of damping, the plot of the real equation is practically the same as when damping is neglected. By introducing sufficient damping, however, the higher instability region may be eliminated. (See fig. II-10.) The two shaft critical speeds and the instability region between them can also be removed by putting enough damping into the rotor supports, although a large amount of damping is required.

BRIEF DESCRIPTION OF VIBRATION MODES

If damping is neglected, the shape of the free vibration modes can be found from the equations of motion (eqs. (1) to (4)) and the form of the solution (eq. (5)). The rotor hub generally moves in an elliptical path in rotating coordinates although, at certain speeds, the motion may become circular or linear. At zero rotational speed, two of the three modes involve hub motion normal to the line of the blades, with concomitant blade motion. In the third mode, the blades do not move about their hinges and the rotor hub moves in a straight line parallel to the line of the blades at a frequency equal to ω_r .

At the first shaft critical speed, the rotor hub diverges in a direction normal to the line of the blades; whereas, at the

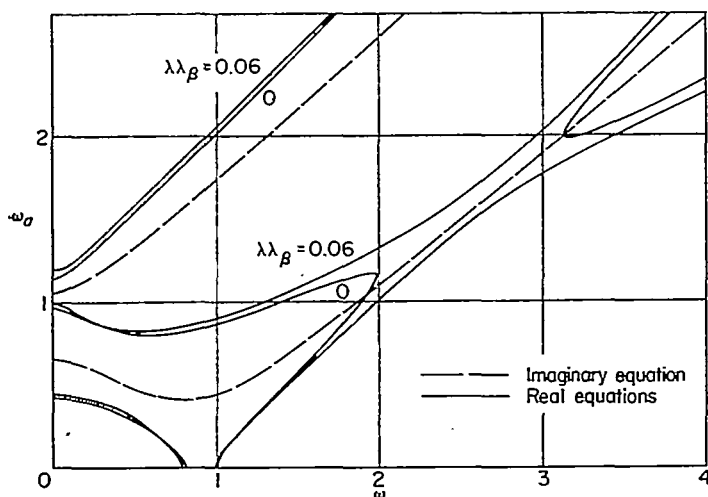

FIGURE II-10.—Plot of real and imaginary equations for case of $\Delta_1=0.05$, $\Delta_2=0.20$, $\Delta_3=0.10$, and $\lambda=\lambda_\beta$.

second shaft critical speed, the hub diverges parallel to the blades.

The forced responses of the system to a vibrator attached to the pylon can also easily be determined and show that those responses lying closest to the lines $\omega_f^2=1$ are the strongest. When the coupling parameter Δ_3 is zero, no response occurs along the lines $\omega_f=|2\omega\pm 1|$. This last conclusion is, of course, necessary if the theory is to give the correct results for the degenerate case of massless rotor blades.

CONCLUSIONS

The mechanical stability of a rotor having two vertically hinged blades mounted upon symmetrical supports has been investigated and reported in this chapter. This investigation indicated that the main features of such a rotor system may be summarized as follows:

1. The vibration modes are generally elliptical, as opposed to circular for the three-blade rotor. The ellipse precesses at a speed ω as observed from a fixed position; the result is six resonant or natural frequencies in a fixed coordinate system for a given rotor speed as against four natural frequencies for the three-blade rotor.
2. The asymmetry of the two-blade-rotor system gives rise to a range of rotor speeds in which self-excited divergence of the rotor occurs. This instability region is bounded by two shaft critical speeds. A three-blade rotor, in contrast, has only one shaft critical speed with no associated instability region.
3. The two-blade rotor has a second region of rotational speeds at which self-excited vibrations occur.

LANGLEY AERONAUTICAL LABORATORY,
NATIONAL ADVISORY COMMITTEE FOR AERONAUTICS,
LANGLEY FIELD, VA., July 27, 1956.

REFERENCES

1. Foote, W. R., Poritsky, H., and Slade, J. J., Jr.: Critical Speeds of a Rotor With Unequal Shaft Flexibilities, Mounted in Bearings of Unequal Flexibility—I. *Jour. Appl. Mech.*, vol. 10, no. 2, June 1943, pp. A-77—A-84.
2. Leone, Peter F.: Mechanical Stability of a Two-Bladed Cantilever Helicopter Rotor. *Jour. Aero. Sci.*, vol. 23, no. 7, July 1956, pp. 633—638.

CHAPTER III

THEORY OF GROUND VIBRATIONS OF A TWO-BLADE HELICOPTER ROTOR ON ANISOTROPIC FLEXIBLE SUPPORTS (REVISED)

By ROBERT P. COLEMAN and ARNOLD M. FBINGOLD

SUMMARY

An extension of previous work on the theory of self-excited mechanical oscillations of hinged rotor blades has been made. Previously published papers cover the cases of three or more rotor blades on elastic supports (such as landing gear) having either equal or unequal support stiffness in different directions and the case of one- or two-blade rotors on supports having equal stiffness in all horizontal directions. The missing case of one or two blades on unequal supports has been treated.

The mathematical treatment of this case is considerably more complicated than the other cases because of the occurrence of differential equations with periodic coefficients. The characteristic frequencies are obtained from an infinite-order determinant. Recurrence relations and convergence factors are used in finding the roots of the infinite determinant.

The results show the existence of ranges of rotational speed at which instability occurs (changed somewhat in position and extent) similar to those possessed by the two-blade rotor on equal supports. In addition, the existence of an infinite number of instability ranges which occurred at low rotor speeds and which did not occur in the cases previously treated is shown.

Simplifications occur in the analysis for the special cases of infinite and zero stiffness in one of the axes. The case of infinite stiffness in one axis is also of special interest because it is mathematically equivalent to a counterrotating rotor system. A design chart for finding the position of the principal self-excited-instability range for the case of infinite support stiffness in one direction is included for the convenience of designers. It is expected that designers will be able to obtain sufficiently accurate information by considering only the cases of infinite and zero support stiffness along one direction together with the cases treated previously.

INTRODUCTION

It is known that rotating-wing aircraft may experience violent vibrations while the rotor is turning and the aircraft is on the ground. It has been found that these vibrations can be explained without considering aerodynamic effects and that they are due to mechanical coupling between horizontal hub displacements and blade oscillations in the plane of rotation. A theoretical analysis of this vibration problem is given in chapters I and II. Chapter I deals with rotors having three or more equal blades on general supports and chapter II deals with two-blade rotors on supports having the same stiffness in all directions.

Although in actual two-blade rotary-wing aircraft, the stiffness of the supports along the longitudinal direction is certainly different from the lateral stiffness, the equality of

the stiffnesses was assumed in chapter II because it permitted the mathematical simplification of dealing with differential equations having constant coefficients and it was believed that a theory employing such an assumption would be sufficient to indicate the nature of the most violent types of ground instability.

The present chapter gives a theoretical investigation of the general case of a two-blade rotor mounted upon supports of unequal stiffness along the two stationary principal axes. It thus generalizes the problem of chapter II, and rounds out the studies of ground resonance begun in chapter I. As was shown in chapter II, a two-blade rotor possesses different dynamic properties along and normal to the line of the blades. Equations of motion with constant coefficients for the problem treated in chapter II could be obtained by using a coordinate system rotating with the rotor. This procedure succeeded because the supports were assumed isotropic (equal stiffness in all directions). When the supports are anisotropic, however, it is impossible to avoid the appearance of periodic coefficients in the equations of motion.

The present method of solving the differential equations of motion follows closely the process employed in reference 1 for a vibration problem in two degrees of freedom. The form of solution is expressed by an exponential factor times a complex Fourier series. Substitution of the formal solution into the equations of motion yields an infinite set of algebraic equations and an infinite-order determinant for the determination of the Fourier coefficients and the characteristic frequencies. The subsequent analysis is concerned with methods of finding the roots of the infinite determinant.

Although the present chapter did not originally include the effects of damping on rotor instability, Mr. George W. Brooks has prepared appendix B to indicate how effects of damping may be included in the analyses.

It is expected that designers will be able to obtain sufficiently accurate information by considering only the cases of infinite or zero support stiffness along one direction together with the cases of chapters I and II. In order to avoid the necessity for extensive calculations, a design chart is included giving the location of the principal self-excited-instability range for the case of infinite support stiffness in one direction.

DERIVATION OF THE EQUATIONS OF MOTION

The symbols used in this chapter are defined in appendix A. The equations of motion are obtained from Lagrange's equations and from the expressions for kinetic and potential

energy. Four degrees of freedom of the rotor system are considered: components of deflection of the rotor hub in the plane of rotation, and hinge deflections of the two rotor blades about their vertical hinges. All motions are thus assumed to occur in the plane of the rotor. The rotor is assumed to rotate at a constant angular velocity ω . The analysis can be applied to rotors without hinges by assuming an effective spring stiffness and hinge position to represent the elastic deflection of the blade.

The pertinent physical parameters are:

- a radial position of vertical hinge
- b distance from vertical hinge to center of mass of blade
- m_b mass of rotor blade
- m effective mass of rotor supports
- r radius of gyration of blade about center of mass
- K_x, K_y spring constants of the rotor supports along the X - and Y -directions, respectively
- K_β spring constant of hinge self-centering spring

Let the origin of the X, Y -coordinate system be placed at the undisturbed position of the rotor hub. At time t equal to 0, the line through the blade hinges and rotor hub is assumed parallel to the X -axis. After a time interval t , let the rotor hub deflection be z and hinge deflections be β_1 and β_2 , respectively, where z is the complex position coordinate measured in a coordinate system rotating with the rotor. (See fig. III-1.) Then the positions of the centers of mass of the two blades, as measured in fixed coordinates, will be, respectively,

$$\left. \begin{aligned} z_1 &= (z + a + be^{i\beta_1})e^{i\omega t} \\ z_2 &= (z - a - be^{i\beta_2})e^{i\omega t} \end{aligned} \right\} \quad (1)$$

The kinetic energy of the rotor system T can be written as

$$T = \frac{1}{2} m_b \left\{ \dot{z}_1 \dot{\bar{z}}_1 + \dot{z}_2 \dot{\bar{z}}_2 + r^2 \left[(\omega + \dot{\beta}_1)^2 + (\omega + \dot{\beta}_2)^2 \right] \right\} + \frac{1}{2} m (\dot{z} + i\omega z)(\dot{\bar{z}} - i\omega \bar{z}) \quad (2)$$

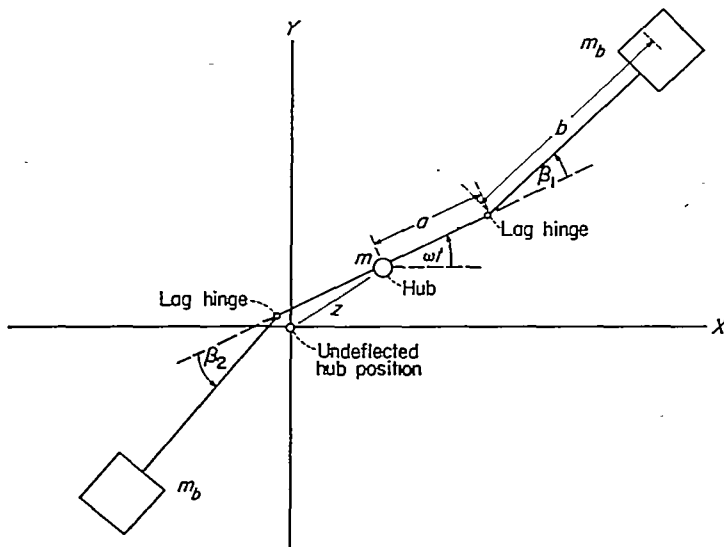

FIGURE III-1.—Simplified mechanical system representing rotor.

The first term in equation (2) represents the kinetic energy of the rotor blades, including the energy due to rotation, and the second term is the contribution of the rotor hub.

Upon expanding equation (1) into power series in β_1 and β_2 (only small deflections from equilibrium being considered) and substituting into equation (2), there is obtained

$$T = \frac{1}{2} M (\dot{z} + i\omega z)(\dot{\bar{z}} - i\omega \bar{z}) + \frac{1}{2} m_b \left[-(\beta_1 - \beta_2)(i\omega^2 b z - i\omega^2 b \bar{z} + \omega b \dot{z} + \omega b \dot{\bar{z}}) + (\beta_1 - \beta_2)(b i \ddot{z} + \omega b z + \omega b \bar{z} - b i \dot{z}) + (b^2 + r^2)(\dot{\beta}_1^2 + \dot{\beta}_2^2) - a b \omega^2 (\beta_1^2 + \beta_2^2) \right] \quad (3)$$

where only the terms that are quadratic in the variables have been retained, and M represents the total mass of the rotor system.

The potential energy of the system V is given by

$$V = \frac{K_\beta}{2} (\beta_1^2 + \beta_2^2) + \frac{K}{2} z \bar{z} - \frac{\Delta K}{4} (z^2 e^{2i\omega t} + \bar{z}^2 e^{-2i\omega t}) \quad (4)$$

where K is the average stiffness and ΔK is a measure of the difference of the two principal stiffnesses; that is,

$$K = \frac{K_y + K_x}{2}$$

$$\Delta K = \frac{K_y - K_x}{2}$$

As in chapters I and II, simplifications in the analysis are introduced by replacing the hinge variables β_1 and β_2 by the following new variables:

$$\theta_0 = \frac{b}{2} (\beta_1 + \beta_2)$$

$$\theta_1 = \frac{b}{2} (\beta_1 - \beta_2)$$

In terms of these new variables the expressions (3) and (4) become, respectively,

$$T = \frac{M}{2} (\dot{z} + i\omega z)(\dot{\bar{z}} - i\omega \bar{z}) + m_b \left[(\dot{\bar{z}} - i\omega \bar{z})(i\dot{\theta}_1 - \omega \theta_1) - (\dot{z} + i\omega z)(i\dot{\theta}_1 + \omega \theta_1) + \left(1 + \frac{r^2}{b^2}\right)(\dot{\theta}_0^2 + \dot{\theta}_1^2) - \frac{a}{b} \omega^2 (\theta_0^2 + \theta_1^2) \right] \quad (5)$$

and

$$V = \frac{K}{2} z \bar{z} + \frac{K_\beta}{b^2} (\theta_0^2 + \theta_1^2) - \frac{\Delta K}{4} (z^2 e^{2i\omega t} + \bar{z}^2 e^{-2i\omega t}) \quad (6)$$

By use of the Lagrangian form of the equations of motion

$$\frac{d}{dt} \left(\frac{\partial T}{\partial \dot{x}} \right) - \frac{\partial T}{\partial x} + \frac{\partial V}{\partial x} = 0$$

the following equations of motion for the rotor system are finally obtained:

$$\ddot{\theta}_0 + (\omega^2 \Lambda_1 + \Lambda_2) \theta_0 = 0 \quad (7)$$

$$(D + i\omega)^2 z + i\mu (D + i\omega)^2 \theta_1 + \frac{K}{M} z - \frac{\Delta K}{M} \bar{z} e^{-2i\omega t} = 0 \quad (8)$$

$$(D-i\omega)^2\bar{z}-i\mu(D-i\omega)^2\theta_1+\frac{K}{M}\bar{z}-\frac{\Delta K}{M}ze^{2i\omega t}=0 \quad (9)$$

$$(D+i\omega)^2z-(D-i\omega)^2\bar{z}+2i\left(1+\frac{r^2}{b^2}\right)(D^2+\Lambda_1\omega^2+\Lambda_2)\theta_1=0 \quad (10)$$

where the notation

$$D=\frac{d}{dt}$$

has been used, and the following combinations of the original parameters have been introduced:

$$\begin{aligned} \mu &= \frac{2m_b}{M} \\ \Lambda_1 &= \frac{a}{b\left(1+\frac{r^2}{b^2}\right)} \\ \Lambda_2 &= \frac{K_\beta}{m_b b^2\left(1+\frac{r^2}{b^2}\right)} \end{aligned}$$

Equations (7) to (10) do not include damping terms. The general equations for the damped case are derived in appendix B and it is shown that both the case for no damping and anisotropic supports, which is treated in the present chapter, and the case for damping and isotropic supports, which was treated in chapter II, are readily obtained as special cases of the generalized equations by neglecting appropriate terms.

Equation (7) can be solved independently of the others since it is an equation in θ_0 alone. The equivalent equation appeared also in chapters I and II, and its solution represents in-phase motion of the blades with no resultant reaction (except torsion) at the rotor hub. This motion will not be further considered in this chapter.

The problem is thus resolved into the solution of the three simultaneous equations (8) to (10). It will be noted that the terms with periodic coefficients in equations (8) and (9) disappear if $\frac{\Delta K}{M}=0$, that is, if $K_r=K_x$. Equations (8) and (9) are thus reduced to the problem treated in chapter II.

FORM OF SOLUTION OF EQUATIONS OF MOTION

The equations of motion (eqs. (8) to (10)) are similar in mathematical properties to Mathieu's equation, which occurs in the analysis of vibrating systems of one degree of freedom with variable elasticity. (See ref. 2.) A generalized form of Mathieu's equation was solved analytically by Hill. (See ref. 3, pp. 413-417.) An extension of Hill's method has been applied in reference 1 to a problem involving two degrees of freedom, and a further development of the method of reference 1 is followed in the present paper.

Equations (8) to (10) constitute a system of linear differential equations with periodic coefficients. Three second-order equations possess six linearly independent solutions that, according to the Floquet theory (ref. 3, p. 412), are of

the form of an exponential factor times a periodic function of time. Particular solutions are of the form

$$\left. \begin{aligned} z &= e^{i\omega_\alpha t}P(t) + e^{-i\bar{\omega}_\alpha t}\bar{Q}(t) \\ \bar{z} &= e^{i\omega_\alpha t}Q(t) + e^{-i\bar{\omega}_\alpha t}\bar{P}(t) \\ \theta_1 &= e^{-i\omega_\alpha t}R(t) + e^{-i\bar{\omega}_\alpha t}\bar{R}(t) \end{aligned} \right\} \quad (11)$$

where ω_α is known as the characteristic exponent, and $P(t)$, $Q(t)$, and $R(t)$ are periodic functions of period π/ω .

Since $P(t)$, $Q(t)$, and $R(t)$ are periodic functions of t , they can be represented by complex Fourier series, and equations (11) become

$$\left. \begin{aligned} z &= \sum_{-\infty}^{\infty} A_l e^{(2l\omega + \omega_\alpha)t} + \sum_{-\infty}^{\infty} \bar{B}_l e^{-(2l\omega + \bar{\omega}_\alpha)t} \\ \bar{z} &= \sum_{-\infty}^{\infty} B_l e^{(2l\omega + \omega_\alpha)t} + \sum_{-\infty}^{\infty} \bar{A}_l e^{-(2l\omega + \bar{\omega}_\alpha)t} \\ \theta_1 &= \sum_{-\infty}^{\infty} C_l e^{(2l\omega + \omega_\alpha)t} + \sum_{-\infty}^{\infty} \bar{C}_l e^{-(2l\omega + \bar{\omega}_\alpha)t} \end{aligned} \right\} \quad (12)$$

where A_l , B_l , and C_l are complex constants.

Equations (11) and (12) show that, when the rotor system is stable and ω_α is real, the motion not only is not simple harmonic as was the case in chapters I and II, but, in general, is not even periodic. The motion can be said to consist of a fundamental frequency ω_α plus "harmonics" of frequency $\omega_\alpha + 2l\omega$ where l is any integer. From equations (12) it is seen that the value of ω_α is not uniquely determinate, since $\omega_\alpha + 2l\omega$ also satisfies equations (12). (The imaginary part of ω_α is definite, however.) It can be shown furthermore that, corresponding to each value of ω_α , $-\omega_\alpha$ is also a solution. Only those three values of ω_α for which the real parts lie between 0 and ω need therefore be considered. These values will be referred to hereinafter as the three "principal" values of ω_α . These values of ω_α differing from the principal value by $2l\omega$, or having opposite sign, will be referred to as "harmonics" of the corresponding principal value.

Since z has been defined as a position coordinate in a rotating frame of reference, the values of ω_α can be interpreted as the natural frequencies of the rotor system in rotating coordinates.

SOLUTION OF EQUATIONS OF MOTION DETERMINANTAL EQUATION

If the formal solution (eqs. (12)) is combined with the equations of motion (eqs. (8) to (10)), and the coefficients of each exponential time factor is separately equated to zero, an infinite set of homogeneous equations is obtained. These equations can be separated into two independent sets. Each equation of one set is the conjugate of an equation of the other set, and only one set need be considered. Thus

$$\left\{ \frac{K}{M} - [\omega_\alpha + (2l+1)\omega]^2 \right\} A_l - \frac{\Delta K}{M} B_{l+1} - \mu i [\omega_\alpha + (2l+1)\omega]^2 C_l = 0 \quad (13)$$

of $\omega_a/\sqrt{K/M}$, as a function of $\omega/\sqrt{K/M}$, are seen to depend only on the values of the three nondimensional parameters, $\Lambda_1, \frac{\Lambda_2}{K/M}$, and Λ_3 and the stiffness-ratio parameter $\Delta K/K$.

A determinant of infinite order has meaning only insofar as it is defined as the limit of a determinant of finite order. Define $\Delta_n(\omega_a)$ as the determinant of order $6n-3$ formed from a square array of $\Delta(\omega_a)$ centered on the term $-1 + \frac{\Lambda_1\omega^2 + \Lambda_2}{\omega_a^2}$. This term, which originally was associated with C_0 in equation (15), will be referred to hereinafter as the "origin" of the infinite determinant $\Delta(\omega_a)$. The choice of this term as center of $\Delta(\omega_a)$ is purely arbitrary, and it was selected solely for reasons of symmetry.

Thus

$$\Delta(\omega_a) = \lim_{n \rightarrow \infty} \Delta_n(\omega_a) \tag{17}$$

The limiting values of the roots of the equation

$$\Delta_n(\omega_a) = 0$$

as n becomes infinite will be the values of the roots of the equation

$$\Delta(\omega_a) = 0$$

The method of calculating the roots of $\Delta(\omega_a) = 0$, by successively calculating the roots of $\Delta_n(\omega_a) = 0$ for larger values of n , is entirely too tedious. Instead, the method reference 1 will be followed. This method involves the calculation of the value of $\Delta(\omega_a)$ for several specified values of ω_a . The roots of $\Delta(\omega_a) = 0$ can then be obtained from a trigonometric equation involving the roots and the calculated values of $\Delta(\omega_a)$.

AUXILIARY DETERMINANTS AND RECURRENCE RELATIONS FOR CALCULATING $\Delta(\omega_a)$

Before the trigonometric equation is derived, it is convenient to have a systematic numerical procedure for determining the value of $\Delta(\omega_a)$. As n becomes infinite, the terms of $\Delta_n(\omega_a)$ extend to infinity both above and below the origin. By expanding $\Delta_n(\omega_a)$ in terms of the elements of the column containing the origin, it can be expressed in terms of auxiliary determinants that extend to infinity in only one direction. Recurrence relations can then be obtained that give the value of these auxiliary determinants.

The auxiliary determinants are minors of $\Delta_n(\omega_a)$ and are defined as follows:

- $C_n(\omega_a)$ determinant of order $3n-2$ consisting of the terms below and to the right of the origin; that is, determinant having first row and column beginning with term $-1 + \frac{K/M}{(\omega_a + \omega)^2}$
- $D_n(\omega_a)$ determinant of order $3n-3$ formed from $C_n(\omega_a)$ by omitting last row and column
- $E_n(\omega_a)$ determinant of order $3n-4$ formed from $D_n(\omega_a)$ by omitting last row and column
- $L_n(\omega_a)$ determinant of order $3n-3$ formed from $C_n(\omega_a)$ by omitting first row and column
- $M_n(\omega_a)$ determinant of order $3n-4$ formed from $L_n(\omega_a)$ by omitting last row and column
- $N_n(\omega_a)$ determinant of order $3n-5$ formed from $M_n(\omega_a)$ by omitting last row and column

The following three determinants will also be needed:

- $G_n(\omega_a)$ determinant of order $3n-4$ formed from $L_n(\omega_a)$ by omitting first row and column
- $H_n(\omega_a)$ determinant of order $3n-5$ formed from $G_n(\omega_a)$ by omitting last row and column
- $I_n(\omega_a)$ determinant of order $3n-6$ formed from $H_n(\omega_a)$ by omitting last row and column

Determinants similar to the foregoing can be formed in the same manner from the upper half of $\Delta_n(\omega_a)$. Denote these determinants by the subscript $-n$ instead of n . It is seen, however, that their values can be obtained from the values of the determinants already defined from the lower half of $\Delta_n(\omega_a)$, by merely replacing ω_a with $-\omega_a$ (for example, $C_{-n}(\omega_a) = C_n(-\omega_a)$).

Expanding $\Delta_n(\omega_a)$ in terms of the elements of the column containing the origin gives

$$\Delta_n(\omega_a) = \left(-1 + \frac{\Lambda_1\omega^2 + \Lambda_2}{\omega_a^2} \right) C_n(\omega_a) C_n(-\omega_a) - \Lambda_3 \left[\left(\frac{\omega_a - \omega}{\omega_a} \right)^2 L_n(-\omega_a) C_n(\omega_a) + \left(\frac{\omega_a + \omega}{\omega_a} \right)^2 L_n(\omega_a) C_n(-\omega_a) \right] \tag{18}$$

The auxiliary determinants $C_n(\omega_a)$, $D_n(\omega_a)$, and $E_n(\omega_a)$ satisfy the following recurrence relations (obtained by expanding each in terms of the elements of its last row):

$$\left. \begin{aligned} C_n(\omega_a) &= \left\{ -1 + \frac{K/M}{[\omega_a + (2n-1)\omega]^2} \right\} D_n(\omega_a) - \Lambda_3 \left[\frac{\omega_a + (2n-1)\omega}{\omega_a + (2n-2)\omega} \right]^2 E_n(\omega_a) \\ D_n(\omega_a) &= \left\{ -1 + \frac{\Lambda_1\omega^2 + \Lambda_2}{[\omega_a + (2n-2)\omega]^2} \right\} E_n(\omega_a) - \Lambda_3 \left[\frac{\omega_a + (2n-3)\omega}{\omega_a + (2n-2)\omega} \right]^2 C_{n-1}(\omega_a) \\ E_n(\omega_a) &= \left\{ -1 + \frac{K/M}{[\omega_a + (2n-3)\omega]^2} \right\} C_{n-1}(\omega_a) - \frac{(\Delta K/M)^2}{[\omega_a + (2n-3)\omega]^4} D_{n-1}(\omega_a) \end{aligned} \right\} \tag{19}$$

The determinants $L_n(\omega_a)$, $M_n(\omega_a)$, and $N_n(\omega_a)$ and also the system $G_n(\omega_a)$, $H_n(\omega_a)$, and $I_n(\omega_a)$ satisfy the same recurrence relations as $C_n(\omega_a)$, $D_n(\omega_a)$, and $E_n(\omega_a)$, respectively.

The values of these nine determinants can be found from the recurrence relations (eqs. (19)) and the following

initial values, obtained directly from equation (16):

$$\left. \begin{aligned}
 C_1(\omega_a) &= -1 + \frac{K/M}{(\omega_a + \omega)^2} \\
 E_2(\omega_a) &= \left[-1 + \frac{K/M}{(\omega_a + \omega)^2} \right]^2 - \frac{(\Delta K/M)^2}{(\omega_a + \omega)^4} \\
 N_2(\omega_a) &= -1 + \frac{K/M}{(\omega_a + \omega)^2} \\
 M_2(\omega_a) &= \left[1 - \frac{K/M}{(\omega_a + \omega)^2} \right] \left[1 - \frac{\Delta_1 \omega^2 + \Delta_2}{(\omega_a + 2\omega)^2} \right] - \Delta_3 \left(\frac{\omega_a + \omega}{\omega_a + 2\omega} \right)^2 \\
 H_2(\omega_a) &= -1 + \frac{\Delta_1 \omega^2 + \Delta_2}{(\omega_a + 2\omega)^2} \\
 G_2(\omega_a) &= \left[1 - \frac{\Delta_1 \omega^2 + \Delta_2}{(\omega_a + 2\omega)^2} \right] \left[1 - \frac{K/M}{(\omega_a + 3\omega)^2} \right] - \Delta_3 \left(\frac{\omega_a + 3\omega}{\omega_a + 2\omega} \right)^2
 \end{aligned} \right\} (20)$$

By use of the initial conditions (eqs. (20)), the recurrence relations (eqs. (19)), and equation (18), the value of $\Delta_n(\omega_a)$ can be calculated. The value of $\Delta(\omega_a)$ will then be the limiting value of $\Delta_n(\omega_a)$ as n becomes infinite.

THE BEHAVIOR OF $\Delta_n(\omega_a)$ FOR LARGE VALUES OF n

So far it has been tacitly assumed that the determinant $\Delta(\omega_a)$, as defined in equations (16) and (17), is convergent, and further, that it remains a function of ω_a in the limit as n becomes infinite; that is, it is not identically equal to zero, independent of the value of ω_a . It will now be shown that the function $\Delta_n(\omega_a)$ does become zero in the limit, independent of ω_a , but that when $\Delta_n(\omega_a)$ is divided by an appropriate function of n , a new function $F_n(\omega_a)$ will be obtained which will be convergent and remain an unambiguous function of ω_a in the limit.

The derivation of the appropriate function by which to divide $\Delta_n(\omega_a)$ evidently depends upon the behavior of $\Delta_n(\omega_a)$ as n becomes very large. As n becomes infinite, the recurrence relations (eqs. (19)) become

$$C_n = -D_n - \Delta_3 E_n \tag{21a}$$

$$D_n = -E_n - \Delta_3 C_{n-1} \tag{21b}$$

$$E_n = -C_{n-1} \tag{21c}$$

with identical equations for $L_n, M_n,$ and N_n and for $G_n, H_n,$ and I_n . Equations (21) are readily solvable since they constitute a system of difference equations with constant coefficients. They are satisfied by solutions of the form

$$C_n = C_0 k^n \tag{22a}$$

where C_0 is some arbitrary constant and k is a constant to be determined. From equations (21c) and (21b), respectively,

$$E_n = -C_0 k^{n-1} \tag{22b}$$

and

$$\begin{aligned}
 D_n &= C_0 k^{n-1} - \Delta_3 C_0 k^{n-1} \\
 &= C_0 (1 - \Delta_3) k^{n-1} \tag{22c}
 \end{aligned}$$

Combining equations (22a), (22b), and (22c) with equation (21a) and dividing through by $C_0 k^{n-1}$ gives

$$k = 2\Delta_3 - 1 \tag{23}$$

Thus, by use of equation (18), it is seen that for large values of n , $\Delta_n(\omega_a)$ varies as k^{2n} . Since by definition Δ_3 must have a value between 0 and 1/2, k^2 must lie between 0 and 1. Thus, in the limit,

$$\lim_{n \rightarrow \infty} \Delta_n(\omega_a) = 0$$

independent of ω_a .

Consider the function

$$F_n(\omega_a) = \frac{\Delta_n(\omega_a)}{k^{2n}}$$

The equation $F_n(\omega_a) = 0$ will obviously have the same roots for ω_a as does $\Delta_n(\omega_a) = 0$. The function $F_n(\omega_a)$ has the advantage, however, as is seen from the preceding discussion, of remaining an unambiguous function of ω_a in the limit as n becomes infinite. Define this limit as

$$\begin{aligned}
 F(\omega_a) &= \lim_{n \rightarrow \infty} F_n(\omega_a) \\
 &= \lim_{n \rightarrow \infty} \frac{\Delta_n(\omega_a)}{k^{2n}} \tag{24}
 \end{aligned}$$

The primary problem can now be redefined as the problem of determining the roots, infinite in number and consisting of $\omega_{a_1}, \omega_{a_2},$ and ω_{a_3} and all their harmonics, of the equation

$$F(\omega_a) = 0 \tag{25}$$

EVALUATION OF ROOTS OF EQUATION (25)

The following trigonometric expression for $F(\omega_a)$ will now be derived:

$$\begin{aligned}
 F(\omega_a) &= \lim_{n \rightarrow \infty} \frac{\Delta_n(\omega_a)}{k^{2n}} \\
 &= \frac{1}{k} \prod_{j=1}^3 \left[\frac{\sin^2 \left(\frac{\pi \omega_a}{2\omega} \right) - \sin^2 \left(\frac{\pi \omega_{a_j}}{2\omega} \right)}{\sin^2 \left(\frac{\pi \omega_a}{2\omega} \right) \cos^4 \left(\frac{\pi \omega_a}{2\omega} \right)} \right] \tag{26}
 \end{aligned}$$

The function $F(\omega_a)$ is seen from equation (24) and equation (16) to be periodic of period 2ω , to have roots $\pm(\omega_{a_1} \pm 2s\omega), \pm(\omega_{a_2} \pm 2s\omega),$ and $\pm(\omega_{a_3} \pm 2s\omega)$ where s is any integer, to have second-order poles at $\omega_a = \pm 2s\omega,$ and to have fourth-order poles at $\omega_a = \pm(s+1)\omega.$ Liouville's function theorem states that a function of a complex variable (in this case, ω_a) that is analytic everywhere in the complex plane, including the region at infinity, must be a constant. It will be shown that $F(\omega_a)$ is finite at infinity (except if ω_a proceeds to infinity along the real axis). If the poles along the real axis could be eliminated by forming a suitable function of $F(\omega_a),$ without at the same time introducing new poles, then that function, by Liouville's theorem, must be a constant.

Such a function of $F(\omega_a),$ which is analytic everywhere in

the complex plane, is

$$J(\omega_a) = \frac{F(\omega_a) \sin^2\left(\frac{\pi\omega_a}{2\omega}\right) \cos^4\left(\frac{\pi\omega_a}{2\omega}\right)}{\prod_{j=1}^3 \left[\sin^2\left(\frac{\pi\omega_a}{2\omega}\right) - \sin^2\left(\frac{\pi\omega_{aj}}{2\omega}\right) \right]} \quad (27)$$

where ω_{a_1} , ω_{a_2} , and ω_{a_3} are the three principal values of ω_a . The function $J(\omega_a)$ is therefore a constant. The value of $J(\omega_a)$ found by making ω_a approach infinity along the imaginary axis is

$$J(\omega_a) = F(\infty)$$

where $F(\infty)$ is the value of $F(\omega_a)$, as ω_a becomes infinite.

The value of $F(\infty)$ can be found by letting $\omega_a \rightarrow \infty$ in $\Delta_n(\omega_a)$ and then letting $n \rightarrow \infty$. From the form of $\Delta_n(\infty)$ it follows that

$$\Delta_n(\infty) = N_{2n}(\infty) = -C_{2n}(\infty)$$

The recurrence relations defining $C_n(\infty)$ are the same as equations (21). The expressions D_n and E_n may be eliminated from equations (21), and, therefore, C_n may be given as follows:

$$C_n = -(1 - 2\Delta_3)C_{n-1}$$

The initial conditions (eqs. (20)) reduce to $C_1 = -1$, from which it follows immediately that

$$\begin{aligned} \Delta_n(\infty) &= -(1 - 2\Delta_3)^{2n-1} \\ &= k^{2n-1} \end{aligned}$$

from equation (23). Therefore

$$F(\infty) = \lim_{n \rightarrow \infty} \frac{\Delta_n(\infty)}{k^{2n}} = \lim_{n \rightarrow \infty} \frac{k^{2n-1}}{k^{2n}} = \frac{1}{k} \quad (28)$$

Thus equations (27) and (28) lead to the evaluation of equation (26).

After equation (26) has been obtained, the problem of determining ω_{a_1} , ω_{a_2} , and ω_{a_3} may be considered theoretically complete inasmuch as equation (26) is really an identity in ω_a . Suppose that ω_a is assigned any specific value in equation (26) and $F(\omega_a)$ is computed to a certain degree of accuracy. If these computations are made for two more values of ω_a ,

all different, equation (26) will have yielded three equations in the three unknowns ω_{a_1} , ω_{a_2} , and ω_{a_3} . These equations can then be solved for the principal values of ω_a . Any degree of accuracy may be achieved by carrying out the computations for $F(\omega_a)$ to a sufficiently large value of n .

The foregoing procedure can be systematized by rewriting equation (26) as

$$\begin{aligned} K\left(\frac{\omega_a}{\omega}\right) &\equiv \prod_{j=1}^3 \left[\sin^2\left(\frac{\pi\omega_a}{2\omega}\right) - \sin^2\left(\frac{\pi\omega_{aj}}{2\omega}\right) \right] \\ &= kF(\omega_a) \sin^2\left(\frac{\pi\omega_a}{2\omega}\right) \cos^4\left(\frac{\pi\omega_a}{2\omega}\right) \end{aligned} \quad (29)$$

A convenient choice for the three arbitrary values of ω_a is $\omega_a = 0, \omega$, and $\omega/2$. The explicit definitions of $K(0)$, $K(1)$, and $K(1/2)$ then become

$$\left. \begin{aligned} K(0) &= -\sin^2\left(\frac{\pi\omega_{a1}}{2\omega}\right) \sin^2\left(\frac{\pi\omega_{a2}}{2\omega}\right) \sin^2\left(\frac{\pi\omega_{a3}}{2\omega}\right) \\ K(1) &= \left[1 - \sin^2\left(\frac{\pi\omega_{a1}}{2\omega}\right) \right] \left[1 - \sin^2\left(\frac{\pi\omega_{a2}}{2\omega}\right) \right] \left[1 - \sin^2\left(\frac{\pi\omega_{a3}}{2\omega}\right) \right] \\ K(1/2) &= \left[\frac{1}{2} - \sin^2\left(\frac{\pi\omega_{a1}}{2\omega}\right) \right] \left[\frac{1}{2} - \sin^2\left(\frac{\pi\omega_{a2}}{2\omega}\right) \right] \left[\frac{1}{2} - \sin^2\left(\frac{\pi\omega_{a3}}{2\omega}\right) \right] \end{aligned} \right\} \quad (30)$$

The equations for evaluating $K(0)$, $K(1)$, and $K(1/2)$ are

$$\left. \begin{aligned} K(0) &= \lim_{\omega_a \rightarrow 0} \left[kF(\omega_a) \sin^2\left(\frac{\pi\omega_a}{2\omega}\right) \cos^4\left(\frac{\pi\omega_a}{2\omega}\right) \right] \\ K(1) &= \lim_{\omega_a \rightarrow \omega} \left[kF(\omega_a) \sin^2\left(\frac{\pi\omega_a}{2\omega}\right) \cos^4\left(\frac{\pi\omega_a}{2\omega}\right) \right] \\ K(1/2) &= \lim_{\omega_a \rightarrow \omega/2} \left[kF(\omega_a) \sin^2\left(\frac{\pi\omega_a}{2\omega}\right) \cos^4\left(\frac{\pi\omega_a}{2\omega}\right) \right] \end{aligned} \right\} \quad (31)$$

Carrying out the limiting operations indicated in equations (31) and using the auxiliary determinants $C_n(\omega_a)$, $D_n(\omega_a)$, and so forth, give

$$\left. \begin{aligned} K(0) &= \lim_{n \rightarrow \infty} \left\{ \frac{\pi^2 [(\Delta_1 \omega^2 + \Delta_2) C_n^2(0) - 2\Delta_3 \omega^2 L_n(0) C_n(0)]}{-4\omega^2 (1 - 2\Delta_3)^{2n-1}} \right\} \\ K(1) &= \lim_{n \rightarrow \infty} \left[\frac{\pi^4 \frac{K_x}{M} \frac{K_y}{M} G_n^2(-\omega)}{16(1 - 2\Delta_3)^{2n-2}} \right] \\ K(1/2) &= \lim_{n \rightarrow \infty} \left\{ \frac{\left[-1 + \frac{4(\Delta_1 \omega^2 + \Delta_2)}{\omega^2} \right] C_n\left(\frac{\omega}{2}\right) C_n\left(\frac{-\omega}{2}\right) - \Delta_3 \left[L_n\left(\frac{-\omega}{2}\right) C_n\left(\frac{\omega}{2}\right) + 9L_n\left(\frac{\omega}{2}\right) C_n\left(\frac{-\omega}{2}\right) \right]}{-8(1 - 2\Delta_3)^{2n-1}} \right\} \end{aligned} \right\} \quad (32)$$

where the quantities in brackets are conveniently represented by $K(0)_n$, $K(1)_n$, and $K(1/2)_n$, respectively. The quantities $K()_n$ are used in numerical computations as approximations to the functions $K()$.

The formulas (32) for $K(0)$, $K(1)$, and $K(1/2)$ converge slowly with increasing n . The convergence can be speeded up greatly by making use of the concept of convergence factors used in reference 1. A convergence factor for $K(\)_n$ is a function of n approaching the limit 1 as n becomes infinite, which, when multiplied by $K(\)_n$, gives an expression which converges rapidly with increasing values of n to the values of $K(\)$. The details of the derivation of an appropriate convergence factor for $K(0)_n$ will be found in appendix C. Convergence factors for $K(1)_n$ and $K(1/2)_n$ are derived in a similar fashion. The resultant expressions are

$$\left. \begin{aligned} K(0) &= \lim_{n \rightarrow \infty} \left[\frac{K(0)_n \sin^2 \frac{\pi\sqrt{Q}}{2}}{\frac{\pi^2 Q}{4} \prod_{j=1}^{n-1} \left(1 - \frac{Q}{4j^2}\right)^2} \right] \\ K(1) &= \lim_{n \rightarrow \infty} \left[\frac{K(1)_n \cos^2 \frac{\pi\sqrt{Q}}{2}}{\prod_{j=1}^{n-1} \left(1 - \frac{Q}{(2j-1)^2}\right)^2} \right] \\ K(1/2) &= \lim_{n \rightarrow \infty} \left[\frac{K(1/2)_n \cos \frac{\pi\sqrt{Q}}{2}}{\prod_{j=1}^{2n-1} \left(1 - \frac{4Q}{(2j-1)^2}\right)} \right] \end{aligned} \right\} \quad (33)$$

where

$$Q = \frac{2\frac{K}{M}(1 - \Lambda_3) + \Lambda_1\omega^2 + \Lambda_2 + 2\Lambda_3\omega^2}{\omega^2(1 - 2\Lambda_3)}$$

For a given value of n , the quantities in brackets are found to be better approximations to the respective values of $K(\)$ than $K(\)_n$ alone.

The method of obtaining the values of ω_a may be summarized as follows. By use of the initial conditions (eqs. (20)) and the recurrence relations (eqs. (19)), the values of the determinants $C_n(0)$, $L_n(0)$, $G_n(-\omega)$, $C_n(\omega/2)$, $C_n(-\omega/2)$, $L_n(\omega/2)$, and $L_n(-\omega/2)$ can be computed for increasing values of n . With the substitution of these values into equations (33) and with the use of equations (32), approximate values of $K(0)$, $K(1)$, and $K(1/2)$ can be computed. The process appears to be rapidly convergent with n , especially for large values of $\omega/\sqrt{K/M}$. The values of ω_{a1} , ω_{a2} , and ω_{a3} can then be found from equations (31), the definitions of $K(0)$, $K(1)$, and $K(1/2)$.

CONDITIONS FOR STABILITY

From equation (13) the condition for stability of the system is seen to be that all three values of ω_a must be real numbers. If any one of them is complex or pure imaginary, then one of the terms in the solution (eqs. (11)) will increase indefinitely with the time, the motion therefore being unstable. This condition implies that the expressions $\sin^2\left(\frac{\pi\omega_{a1}}{2\omega}\right)$, $\sin^2\left(\frac{\pi\omega_{a2}}{2\omega}\right)$, and $\sin^2\left(\frac{\pi\omega_{a3}}{2\omega}\right)$ all are real positive numbers less

than or equal to 1. The conditions for stability can be expressed directly in terms of $K(0)$, $K(1)$, and $K(1/2)$ by means of their definitions (eqs. (30)). The three equations (30) are formally equivalent to a single cubic equation

$$x^3 + bx^2 + cx + d = 0$$

the roots x_1 , x_2 , and x_3 of which are $\sin^2\left(\frac{\pi\omega_{a1}}{2\omega}\right)$, $\sin^2\left(\frac{\pi\omega_{a2}}{2\omega}\right)$, and so forth, and the coefficients b , c , and d of which are functions of $K(0)$, $K(1)$, and $K(1/2)$ where

$$2b = 4K(0) + 4K(1) - 8K\left(\frac{1}{2}\right) - 3$$

$$2c = -6K(0) - 2K(1) + 8K\left(\frac{1}{2}\right) + 1$$

$$d = K(0)$$

After some manipulations involving the Descartes rule of signs, the necessary and sufficient conditions for stability are found to be

$$\left. \begin{aligned} 0 &\leq -K(0) \leq 1 \\ 0 &\leq K(1) \leq 1 \\ -1 &\leq 8K(1/2) \leq 1 \\ \Delta &= 18bcd - 4b^3d + b^2c^2 - 4c^3 - 27d^3 \geq 0 \end{aligned} \right\} \quad (34)$$

The quantity Δ is the discriminant of the cubic equation.

SPECIAL CASES OF GENERAL THEORY

Three special cases of the general theory are of interest. These cases are the cases for which one of the principal stiffnesses K_y is respectively zero, equal, or infinite in magnitude in comparison with the second principal stiffness K_x .

CASE OF $K_y = K_x$

The case of $K_y = K_x$ has been treated in chapter II. If $K_y = K_x$, equations (8) to (10) reduce to the equations of chapter II. In this special case, the motion of the rotor system becomes simple harmonic, since all the coefficients A_i , B_i , and C_i in equations (12) are identically zero except A_0 , B_0 , and C_0 .

CASE OF $K_y = 0$

The special limiting case of $K_y = 0$ is of interest in the case of a pylon of which the stiffness is negligible along one principal direction with interest centered on the frequencies involving the other principal stiffness. In the case of $K_y = 0$, the function $K(1)$ as given by equations (32) becomes identically zero. This result is also evident from the original definition of $K(1)$ as given in equation (28), because one of the values of ω_a , say ω_{a3} , is of necessity equal to $\pm\omega$. (It will be recalled that ω_a is the frequency as measured in rotating coordinates. In fixed coordinates it would be zero.)

It is possible to give much simpler stability criterions for this case because there are only two K -functions, $K(0)$ and $K(1/2)$, and two values of ω_a , ω_{a_1} and ω_{a_2} , to be determined. The new K -functions may be defined as follows:

$$\left. \begin{aligned} K_1 &= \sin^2\left(\frac{\pi\omega_{a_1}}{2\omega}\right) \sin^2\left(\frac{\pi\omega_{a_2}}{2\omega}\right) = -K(0) \\ K_2 &= \cos^2\left(\frac{\pi\omega_{a_1}}{2\omega}\right) \cos^2\left(\frac{\pi\omega_{a_2}}{2\omega}\right) = \frac{1+2K(0)-8K\left(\frac{1}{2}\right)}{2} \end{aligned} \right\} (35)$$

In terms of K_1 and K_2 , the criterions for stability become

$$0 \leq K_1 \leq 1 \quad (36a)$$

$$0 \leq K_2 \leq 1 \quad (36b)$$

$$\sqrt{K_1} + \sqrt{K_2} \leq 1 \quad (36c)$$

Given the values of K_1 and K_2 , the values of ω_{a_1} and ω_{a_2} can be determined from equations (35). A graph of the relation in equations (35) is given in figure III-2 by means of which the real values of ω_{a_1} and ω_{a_2} can be read off directly once K_1 and K_2 are known.

A graph showing the variation of K_1 and K_2 with $\frac{\omega^2}{K_x/M}$ for the typical parameters $\Delta_1=0.1$, $\Delta_2=0$, $\Delta_3=0.1$, and $K_y=0$, is shown in figure III-3. By use of figure III-2 the values of ω_{a_1} and ω_{a_2} can be obtained. These values are shown in figure III-4 plotted against $\omega/\sqrt{K_x/M}$. Calculations are carried down to $\frac{\omega}{\sqrt{K_x/M}}=0.5$. The general behavior below this speed is discussed in the section entitled "General Behavior of Rotor System as a Function of Rotor Speed."

CASE OF $K_y = \infty$

The formulas for the limiting case of $K_y = \infty$ cannot be obtained conveniently from the general theory. Instead of carrying out the limiting process, it appears preferable to begin by treating the problem as one of only three degrees of

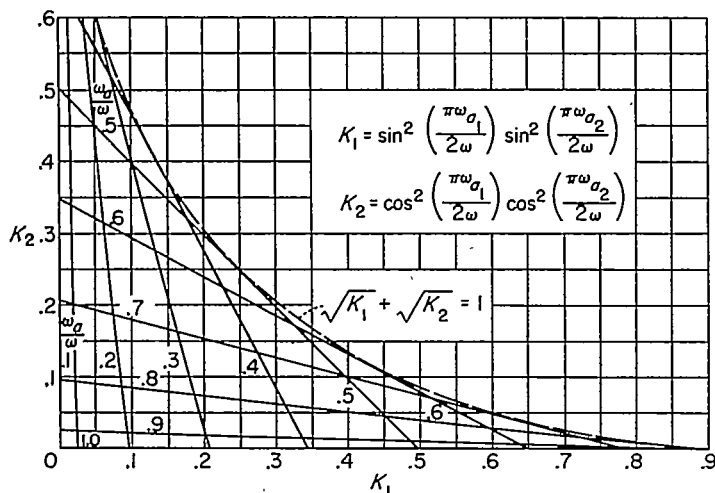

FIGURE III-2.—Chart for obtaining principal value of ω_a from values of K_1 and K_2 . $K_y=0$ or $K_y=\infty$.

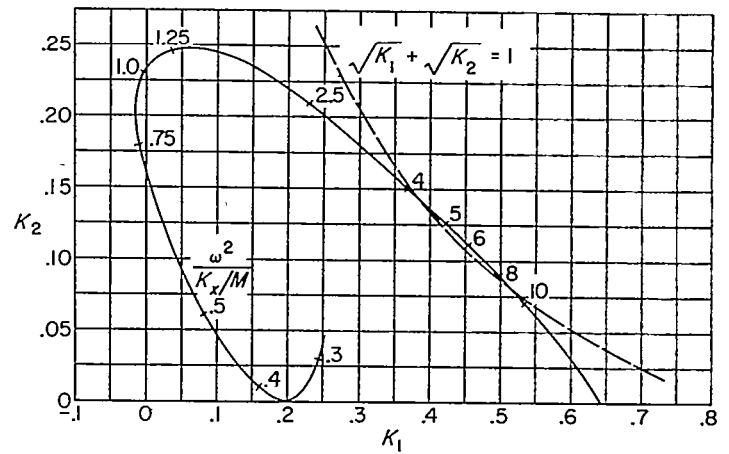

FIGURE III-3.—Graph of K_1 and K_2 as functions of rotor speed ω for $\Delta_1=0.1$, $\Delta_2=0$, $\Delta_3=0.1$, and $K_y=0$.

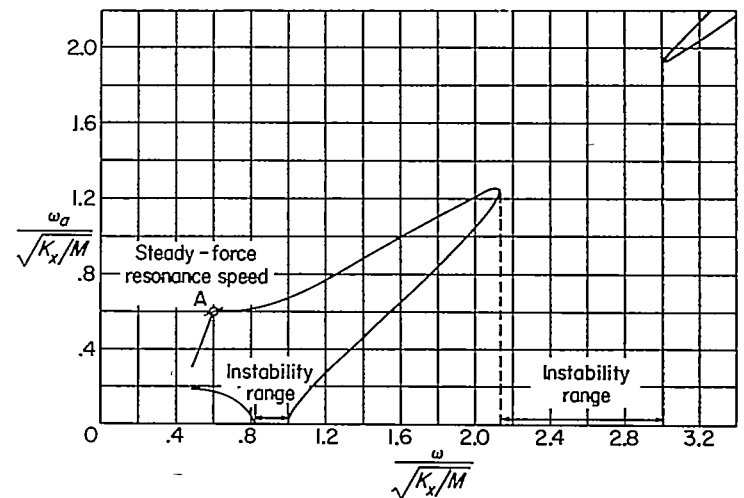

FIGURE III-4.—Principal values of ω_a plotted against rotor speed ω for case of $\Delta_1=0.1$, $\Delta_2=0$, $\Delta_3=0.1$, and $K_y=0$.

freedom (two hinge-deflection coordinates and one hub-position coordinate x) and by developing the theory along lines similar to those used for the general treatment. In this way a system of two simultaneous equations with periodic coefficients is obtained, with the variables θ_1 and x . These equations are solved in a manner similar to that for the general case, the treatment being simpler, however, since the solution has only two principal values of ω_a .

The details of the solution of the equations of motion, together with the final formulas for the K -functions, including convergence factors, are given in appendix D. It is found that the same K_1 and K_2 occur as for $K_y=0$. The criterions for stability are exactly the same as those for $K_y=0$, the conditions of equations (36). Figure III-2 can also be used to determine the values of ω_a from the values of K_1 and K_2 .

A graph giving the variation of K_1 and K_2 with $\frac{\omega^2}{K_x/M}$ for the parameters $\Delta_1=0.1$, $\Delta_2=0$, $\Delta_3=0.1$, and $K_y=\infty$ is shown in figure III-5. In figure III-6 the values of $\omega_{a_1}/\sqrt{K_x/M}$ and $\omega_{a_2}/\sqrt{K_x/M}$ are shown plotted against $\omega/\sqrt{K_x/M}$.

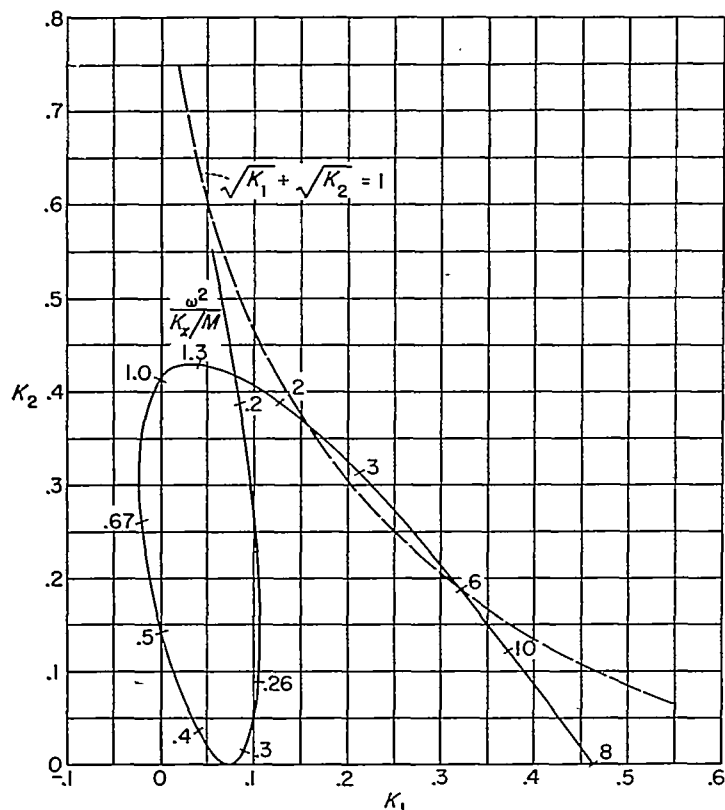

FIGURE III-5.—Graph of K_1 and K_2 as functions of the rotor speed ω for $\Delta_1=0.1$, $\Delta_2=0$, $\Delta_3=0.1$, and $K_v=\infty$.

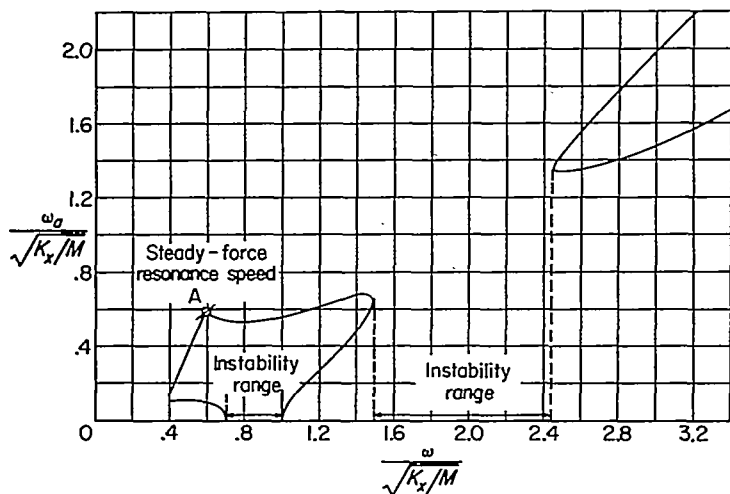

FIGURE III-6.—Principal values of ω_a plotted against rotor speed ω for case of $\Delta_1=0.1$, $\Delta_2=0$, $\Delta_3=0.1$, and $K_v=\infty$.

DISCUSSION OF RESULTS

TYPES OF INSTABILITY

Instability may occur as a result of the violation of any one of the stability criteria of equations (34). Violation of each condition is associated with a different type of instability, which would show up differently in the motion of the rotor system. Experience with computations indicates, however, that the criteria of most practical importance for

helicopters are

$$\begin{aligned}\Delta &\geq 0 \\ -K(0) &\geq 0 \\ K(1) &\geq 0\end{aligned}$$

Similarly, the important criteria in the limiting cases of $K_v=0$ and $K_v=\infty$ are

$$\begin{aligned}\sqrt{K_1} + \sqrt{K_2} &\leq 1 \\ K_1 &\geq 0 \\ K_2 &\geq 0\end{aligned}$$

If the condition $\Delta \geq 0$ or ($\sqrt{K_1} + \sqrt{K_2} \leq 1$) is violated, the other conditions being satisfied, then ω_{a1} and ω_{a2} will be complex conjugates, and the rotor system will execute self-excited vibrations at frequencies, in general, incommensurate with the rotor speed. (Higher harmonics will also be present.) This type of instability will be referred to hereinafter as a "self-excited vibration."

If the stability condition $-K(0) \geq 0$ (or $K_1 \geq 0$) alone is violated, then one of the values of ω_a will be a pure imaginary number. Physically, the rotor system will execute self-excited vibrations having a basic frequency, as seen in rotating coordinates, of zero. This behavior is similar to the ordinary critical-speed behavior of a shaft. Frequencies at higher harmonics $2n\omega$ will also be present. This type of instability will be referred to as a "self-excited whirling."

The third stability condition $K(1) \geq 0$ cannot be violated since $K(1)$ as given by equation (32) cannot be negative. However, $K(1)$ can be exactly equal to zero. (A similar statement applies to K_2 .) At such a point, where the rotor system is on the border line between stability and instability, one of the values of ω_a will be equal to $\pm\omega$. In fixed coordinates this result means that the rotor system will have a natural frequency equal to zero. The rotor system will, therefore, be in resonance with a steady force—a force of zero frequency. The amplitude of the zero-frequency term for the hub motion in such a situation can be shown to be zero, but the blades will oscillate. Also, higher harmonic terms, notably the term of frequency 2ω (in nonrotating coordinates), will show up in the hub motion. This type vibration, which is a resonance phenomenon and not a self-excited vibration, will be called a "steady-force resonance" vibration.

Each of the vibrations described—self-excited vibrations, self-excited whirling, and a steady-force resonance vibration—appeared in the discussion of the two-blade rotor on equal supports (chapter II); however, there the motions were simple harmonic, no higher harmonics being present.

GENERAL BEHAVIOR OF ROTOR SYSTEM AS A FUNCTION OF ROTOR SPEED

The approximate location of the instability regions can easily be found by examining the limiting case of $\Delta_3=0$, that is, the case of zero coupling between the blade and hub

motions. For simplicity, the discussion is also restricted to the case of free hinges ($\Delta_2=0$) and $K_y=\infty$. The K_1 and K_2 functions become

$$\left. \begin{aligned} K_1 &= \sin^2\left(\frac{\pi}{2}\sqrt{\Delta_1}\right) \cos^2\left(\frac{\pi}{2\omega}\sqrt{\frac{K_x}{M}}\right) \\ K_2 &= \cos^2\left(\frac{\pi}{2}\sqrt{\Delta_1}\right) \sin^2\left(\frac{\pi}{2\omega}\sqrt{\frac{K_x}{M}}\right) \end{aligned} \right\} \quad (37)$$

Eliminating the rotor speed ω from equations (37) gives

$$\frac{K_1}{\sin^2\left(\frac{\pi}{2}\sqrt{\Delta_1}\right)} + \frac{K_2}{\cos^2\left(\frac{\pi}{2}\sqrt{\Delta_1}\right)} = 1$$

which considered as an equation in the variables K_1 and K_2 represents a straight-line segment (one of the lines in fig. III-2) terminated by the K_1 and K_2 axes. The segment can be shown to be tangent to the curve $\sqrt{K_1} + \sqrt{K_2} = 1$. As ω decreases, the representative point moves up and down the line segment, performing an infinite number of such oscillations as ω approaches zero. Whenever $K_1=0$, the point is at a self-excited-whirling speed. The corresponding speed is

$$\omega = \frac{\sqrt{K_x/M}}{2s+1}$$

where s represents any positive integer. Thus a self-excited whirling will occur when the rotor speed is approximately equal to $1, \frac{1}{2}, \frac{1}{3}, \frac{1}{4}$, and so forth of the natural frequency of the hub $\sqrt{K_x/M}$. Similarly it can be shown that there will be a steady-force resonance vibration whenever the rotor speed is approximately equal to $\frac{1}{2}, \frac{1}{4}, \frac{1}{6}$, and so forth of the hub natural frequency $\sqrt{K_x/M}$. Finally self-excited vibrations will occur at rotor speeds approximately equal to

$$\omega = \frac{\sqrt{K_x/M}}{2s+1-\sqrt{\Delta_1}}$$

Figure III-7 shows the general pattern of response frequency plotted against rotor speed for a small value of the mass-ratio parameter Δ_3 . Along the horizontal parts of the curves, blade motion predominates over pylon motion. Pylon motion predominates along the slanting parts.

Although the foregoing discussion was developed for the case of $K_y=\infty$, it is believed to apply equally well to the case of $K_y=0$ and also to the general case of $K_y \neq K_x$ if the rotor hub is considered to have two natural frequencies $\sqrt{K_x/M}$ and $\sqrt{K_y/M}$, each frequency having associated with it an infinite set of instability ranges located at approximately the speeds given.

COMPARISON OF RESULTS FOR DIFFERENT VALUES OF K_y/K_x

Figures III-4 and III-6 give the principal values of $\omega_d/\sqrt{K_x/M}$ plotted against the rotor speed $\omega/\sqrt{K_x/M}$ for $K_y=0$ and $K_y=\infty$, respectively, both calculated for the

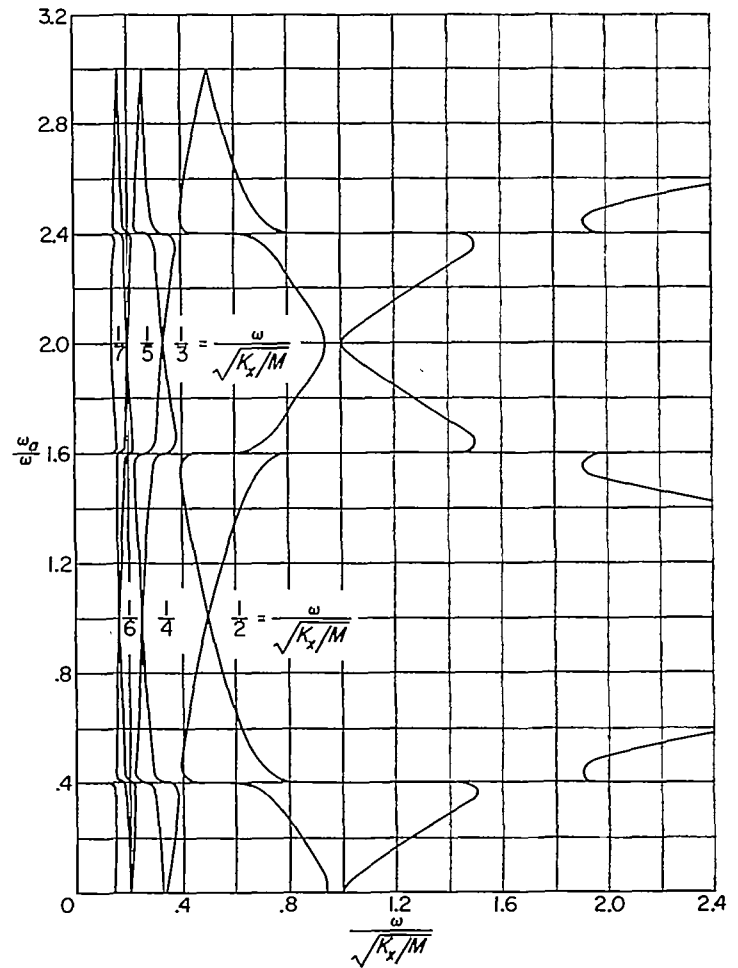

FIGURE III-7.—Typical pattern of response frequencies against rotor speed ω for a small value of the mass-ratio parameter Δ_3 .

same set of parameters Δ_1, Δ_2 , and Δ_3 . The calculations have been carried down to $\frac{\omega}{\sqrt{K_x/M}}=0.4$. The similarity between the two curves is striking. So far as the calculations have been carried, each system shows the presence of one self-excited-vibration instability range, one self-excited-whirling instability range, and one steady-force resonance speed A . If the calculations were carried to lower values of ω , further instability ranges and steady-force resonance speeds would appear.

For comparison, the response frequencies of a two-blade rotor on equal supports ($K_y=K_x$) for the same set of parameters is shown in figure III-8. The frequencies were calculated from the formula in chapter II. Down to $\frac{\omega}{\sqrt{K_x/M}}=0.5$, this chart is very similar to figures III-4 and III-6. In addition it shows one range of rotational speed at which self-excited-vibration instability occurs, one range of rotational speed at which self-excited-whirling instability occurs, and one range of rotational speed at which a steady-force resonance speed occurs. Figure III-8 differs principally from the figures for $K_y \neq K_x$ in that it shows no further instability ranges at low values of ω .

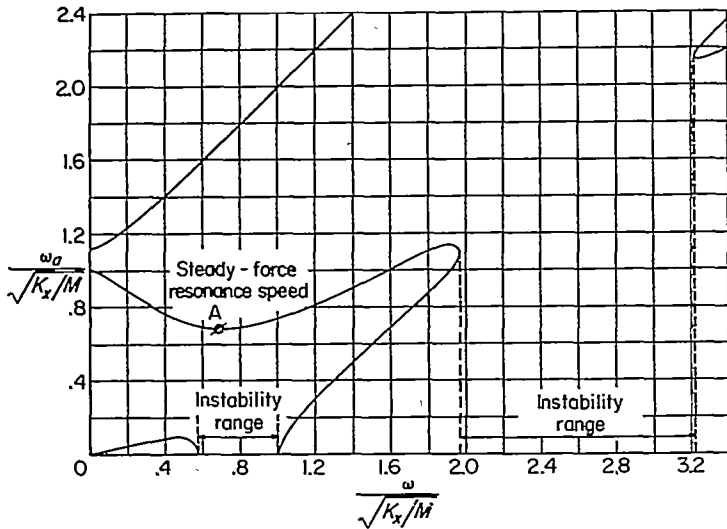

FIGURE III-8.—Response frequencies of a two-blade rotor on symmetric supports for $\Delta_1=0.1$, $\Delta_2=0$, $\Delta_3=0.1$, and $K_y=K_x$.

In chapters I and II charts are presented giving the location of the self-excited-vibration instability range for various values of the parameters Δ_1 , Δ_2 , and Δ_3 . A similar chart for the case of a two-blade rotor with $K_y=\infty$ is given in figure III-9. In using the chart, a straight line is drawn representing the variation of $\frac{\omega^2}{K_x/M}$ with the function $\frac{\Delta_1\omega^2 + \Delta_2}{K_x/M}$. The intersections of this line with the appropriate Δ_3 curves give the beginning and end points of the instability range. The dashed line in figure III-9 indicates the stability ranges for the parameters of figure III-6.

Some observations concerning the relative location and extent of the various instability ranges in figures III-4, III-6, and III-8 appear to be applicable to a wide range of values of the parameters Δ_1 , Δ_2 , and Δ_3 . Thus the self-excited-vibration instability range in the case of $K_y=K_x$ (fig. III-8) is wider (and hence the vibration probably more severe) than the corresponding ranges in the cases of $K_y=0$ and $K_y=\infty$. (See figs. III-4 and III-6.) Also, this instability range occurs at lower rotor speeds in the case of $K_y=\infty$ than it does in the cases of $K_y=K_x$ and $K_y=0$. The self-excited-whirling instability range is considerably narrower for $K_y=\infty$ than it is for the $K_y=K_x$ case, and it is still narrower in the $K_y=0$ case.

In the general case of $K_y \neq K_x$ the location and extent of the instability ranges can be found fairly accurately by considering the problem as the superposition of two problems, one of finding the significant rotor speeds referred to $\sqrt{K_x/M}$ as reference frequency with K_y assumed infinite and the other of finding the significant rotor speeds referred to $\sqrt{K_y/M}$ as reference frequency with K_x assumed zero. With the foregoing discussion as a guide, sufficiently accurate design information can be obtained without extensive calculations for each value of K_y/K_x encountered in practice.

EFFECT OF DAMPING

Although the effect of damping has not been examined mathematically, because complications would be introduced

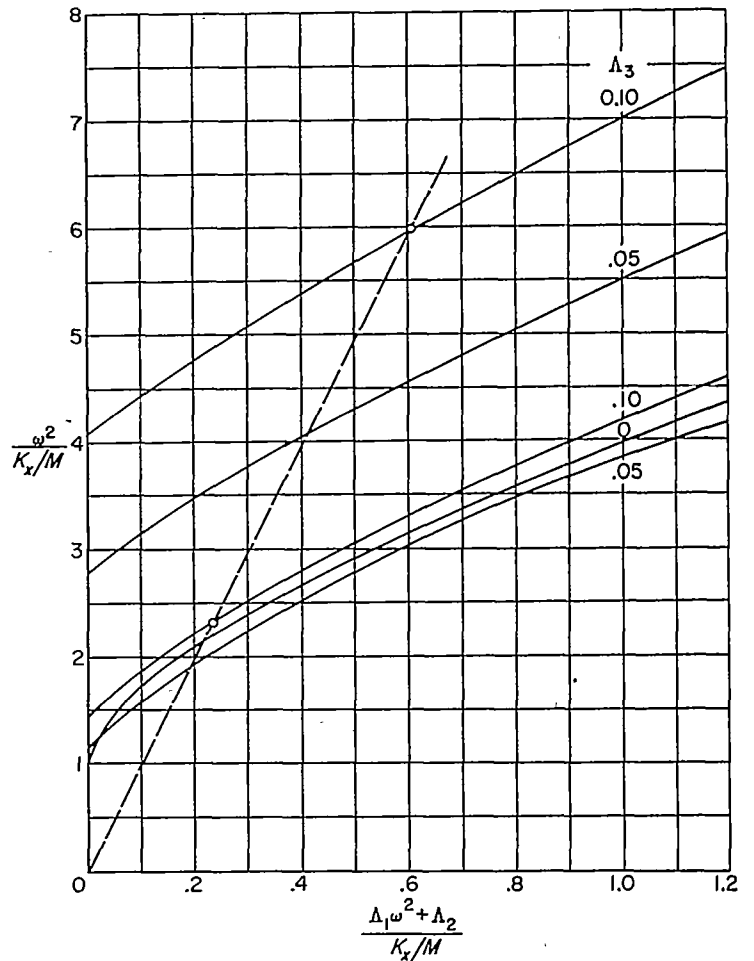

FIGURE III-9.—Chart giving position of the main instability range for $K_y=\infty$.

in the analysis, several inferences from the damping investigations in chapters I and II can probably be safely applied to the rotor-system studies in the present report. The numerous instability ranges occurring at low rotor speeds, which are very narrow and represent a mild type of instability, are probably completely eliminated by the presence of a slight amount of damping in the rotor system. The primary self-excited-vibration instability range can probably be narrowed and eliminated by introducing sufficient damping into both the rotor supports and the blade hinges.

APPLICATION TO DUAL ROTORS

It is easily shown that the analysis for the case of $K_y=\infty$ applies also to the case of a counterrotating rotor system consisting of two equal two-blade rotors revolving at equal speeds and acting equally upon the same flexible member. The rotors may be on the same shaft or on different shafts so long as the nonrotating flexible member is the same for both rotors. The supports, moreover, may have unequal stiffness in the X- and in the Y-directions, provided that the undeflected blade positions make equal angles with a principal stiffness axis.

The proof consists in showing that the energy expressions for the dual-rotating system can be separated into two independent sets of terms, each of which is of the same form as

for a single rotor with $K_y = \infty$. The resulting equations of motion will thus also be the same.

The separation is accomplished by introducing new variables

$$\xi_1 = \frac{1}{2} (\theta_{1_{pos}} - \theta_{1_{neg}})$$

$$\xi_0 = \frac{1}{2} (\theta_{0_{pos}} - \theta_{0_{neg}})$$

and

$$\eta_1 = \frac{1}{2} (\theta_{1_{pos}} + \theta_{1_{neg}})$$

$$\eta_0 = \frac{1}{2} (\theta_{0_{pos}} + \theta_{0_{neg}})$$

where the subscripts *pos* and *neg* refer to the θ 's defined for the rotor turning in the positive direction and for the rotor turning in the opposite direction, respectively. The energy expressions become

$$\left. \begin{aligned} T = & \frac{1}{2} M \dot{x}^2 + 2m_b \left[-2\dot{x}(\dot{\xi}_1 \sin \omega t + \omega \xi_1 \cos \omega t) + \right. \\ & \left. \left(1 + \frac{r^2}{b^2} \right) (\dot{\xi}_1^2 + \dot{\xi}_0^2) - \frac{a}{b} \omega^2 (\xi_1^2 + \xi_0^2) \right] + \\ & \frac{1}{2} M \dot{y}^2 + 2m_b \left[2\dot{y}(\dot{\eta}_1 \cos \omega t - \omega \eta_1 \sin \omega t) + \right. \\ & \left. \left(1 + \frac{r^2}{b^2} \right) (\dot{\eta}_1^2 + \dot{\eta}_0^2) - \frac{a}{b} \omega^2 (\eta_1^2 + \eta_0^2) \right] \\ V = & \frac{2K_\beta}{b^2} (\xi_1^2 + \xi_0^2 + \eta_1^2 + \eta_0^2) + \frac{1}{2} K_x x^2 + \frac{1}{2} K_y y^2 \end{aligned} \right\} \quad (38)$$

where M is the total mass of the system ($M = m + 4m_b$).

From equations (38) it is seen that ξ is coupled only with x and η is coupled only with y . Equations (38) yield equations of motion of the same form as equations (D2) and (D3).

The stability properties for the dual-rotating case are thus exactly the same as in the case of $K_y = \infty$ for the single-rotating two-blade rotor. In particular, figure III-9 can be used to find the location of the primary self-excited-vibration instability range. The value of Λ_3 for the dual-rotating

rotor is defined as $\Lambda_3 = \frac{2m_b}{(m+4m_b) \left(1 + \frac{r^2}{b^2} \right)}$ rather than

$\Lambda_3 = \frac{m_b}{(m+2m_b) \left(1 + \frac{r^2}{b^2} \right)}$ as for the single-rotating rotor. All

other parameters are the same for both cases.

The quantity $\xi_1 \sin \omega t$ can be interpreted physically as the x -component of the displacement of the center of gravity of the blades due to hinge deflections. The quantity $\eta_1 \cos \omega t$ is the corresponding y -component. The separation of the variables means, physically, that the motion of the system

can be separated into two independent modes, each of which involves linear motion of the supports along one of the principal stiffness axes.

Similarly, the stability of counterrotating rotor systems of six or more equal blades can be determined from the results of chapter I with $K_y = \infty$.

CONCLUSIONS

The following conclusions are indicated by the results of an investigation of the problem of vibration of a two-blade helicopter rotor on supports that have different stiffnesses along the two principal stiffness axes:

1. Many speed ranges are found in which self-excited oscillations can occur. These oscillations are of two types—self-excited vibration and self-excited whirling. There are also many speeds at which steady-force-resonance vibration may occur.

2. A stability chart which shows the self-excited vibration, self-excited whirling, and steady-force resonance speeds of the highest rotor speed for each support natural frequency for a two-blade rotor on anisotropic supports is similar in appearance to a stability chart for a two-blade rotor on isotropic supports. However, for the same rotor parameters, the instability regions are changed somewhat in position and extent.

3. Mild self-excited-whirling speed ranges exist at rotor speeds approximately $\frac{1}{2}$, $\frac{1}{3}$, $\frac{1}{4}$, and so forth of each support natural frequency. Steady-force resonance speeds exist at approximately $\frac{1}{2}$, $\frac{1}{4}$, $\frac{1}{6}$, and so forth of each support frequency. Self-excited vibrations also occur at certain low rotor speeds. All these mild instability ranges are probably eliminated by the presence of moderate amounts of damping in the system.

4. A familiarity with typical results of limiting cases of the support-spring constants $K_y = \infty$, $K_y = K_x$, and $K_y = 0$ should enable a designer to avoid extensive calculations of cases of unequal support stiffness. In the general case of unequal support stiffness, the location and extent of the instability ranges can be found fairly accurately by considering the problem as the superposition of two problems, one of finding significant rotor speeds referred to one support frequency $\sqrt{K_x/M}$ as reference frequency with K_y assumed infinite and the other of finding the significant rotor speeds referred to the other support frequency $\sqrt{K_y/M}$ as reference frequency with K_x assumed zero.

5. The analysis of a four-blade counterrotating rotor system in which the rotors cross along the principal stiffness axes of the rotor supports leads to the same equations as those considered for the special case of $K_y = \infty$, and the stability properties are given by the investigation of that special case.

LANGLEY AERONAUTICAL LABORATORY,
NATIONAL ADVISORY COMMITTEE FOR AERONAUTICS,
LANGLEY FIELD, VA., August 24, 1956.

APPENDIX A

SYMBOLS

a	radial position of vertical hinge elements of determinant defined in equation (16)	V	potential energy
$a_{0,0}, a_{0,1},$ and so forth		x, y	deflection of rotor hub measured in fixed X, Y -coordinate system
A_i, B_i, C_i	Fourier coefficients in equations (12)	x_r, y_r	deflection of rotor hub measured in rotating X, Y -coordinate system
$\bar{A}_i, \bar{B}_i, \bar{C}_i$	complex conjugates of $A_i, B_i,$ and $C_i,$ respectively	X, Y	fixed rectangular coordinate axes taken parallel to the principal stiffness directions of the rotor hub
b	distance from vertical hinge to center of mass of blade	z	complex position coordinate of the rotor hub in rectangular coordinate system rotating with angular velocity, $x_r + iy_r$
$C_n(\omega_a), D_n(\omega_a),$ and so forth	minors of the determinate $\Delta_n(\omega_a)$	\bar{z}	complex conjugate of $z, x_r - iy_r$
D	time-derivative operator, $\frac{d}{dt}$	β_1, β_2	angular hinge deflections of rotor blades, respectively
$F(\omega_a) = \lim_{n \rightarrow \infty} F_n(\omega_a)$		Δ	discriminant of cubic equation $x^3 + bx^2 + cx + d = 0$
$F_n(\omega_a) = \frac{\Delta_n(\omega_a)}{k^{2n}}$		$\Delta(\omega_a)$	determinant of infinite order defined by equation (16)
j, n, s	integers	$\Delta_n(\omega_a)$	determinant of order $6n-3$ formed from $\Delta(\omega_a)$
$J(\omega_a)$	function of $F(\omega_a)$ defined by equation (27)	$\theta_0 = \frac{b}{2}(\beta_1 + \beta_2)$	
$k = 2\Lambda_3 - 1$		$\theta_1 = \frac{b}{2}(\beta_1 - \beta_2)$	
$K(\omega_a/\omega)$	function of ω_a/ω defined in equation (29)	$\Lambda_1 = \frac{a}{b\left(1 + \frac{r^2}{b^2}\right)}$	
$K(0), K(1), K(1/2)$	functions defined by equations (30)	$\Lambda_2 = \frac{K_\beta}{m_b b^2 \left(1 + \frac{r^2}{b^2}\right)}$	
K_1, K_2	functions defined by equations (35)	$\Lambda_3 = \frac{\mu}{2\left(1 + \frac{r^2}{b^2}\right)}$	
K_x, K_y	spring constants of the rotor supports along the X - and Y -directions, respectively	$\xi_1, \xi_0, \eta_1, \eta_0$	blade variables for counterrotating rotor
K	average stiffness of rotor supports, $\frac{K_y + K_x}{2}$	μ	mass ratio, $\frac{2m_b}{M}$
$\Delta K = \frac{K_y - K_x}{2}$		ω	constant angular velocity of rotor
K_β	spring constant of blade self-centering spring	ω_a	characteristic exponent or natural frequency of rotor system as viewed in coordinates rotating at angular velocity ω
m	effective mass of rotor supports	$\omega_{a_1}, \omega_{a_2}, \omega_{a_3}$	principle values of ω_a
m_b	mass of rotor blade		
M	total mass of two-blade rotor system, $m + 2m_b$		
$P(t), Q(t), R(t)$	periodic functions defined in equations (11)		
$\bar{P}(t), \bar{Q}(t), \bar{R}(t)$	complex conjugates of $P(t), Q(t),$ and $R(t),$ respectively		
Q	constant defined in equations (33)		
r	radius of gyration of blade about center of mass		
t	time		
T	kinetic energy		

APPENDIX B

THE GENERAL EQUATIONS OF MOTION FOR TWO-BLADE ROTORS

By GEORGE W. BROOKS

GENERAL CASE

The present chapter, although it generalizes the theory of ground vibrations of two-blade rotors by treating the case of anisotropic supports, does not consider the effects of damping. Chapter II treated the case of isotropic supports or equal pylon stiffness in all horizontal directions and included damping. The more general case is one which involves the treatment of the two-blade rotor with anisotropic supports and damping. The equations of motion for this case, derived in the complex coordinate notation of the present report, are given in this appendix.

The equations for the kinetic and potential energies of the rotor system are given by equations (5) and (6) of chapter III as follows:

$$T = \frac{M}{2} (\dot{z} + i\omega z) (\dot{\bar{z}} - i\omega \bar{z}) + m_b \left[(\dot{\bar{z}} - i\omega \bar{z}) (i\dot{\theta}_1 - \omega \theta_1) - (\dot{z} + i\omega z) (i\dot{\theta}_1 + \omega \theta_1) + \left(1 + \frac{r^2}{b^2}\right) (\dot{\theta}_0^2 + \dot{\theta}_1^2) - \frac{a}{b} \omega^2 (\theta_0^2 + \theta_1^2) \right] \quad (B1)$$

$$V = \frac{K}{2} z \bar{z} + \frac{K_\beta}{b^2} (\theta_0^2 + \theta_1^2) - \frac{\Delta K}{4} (z^2 e^{2i\omega t} + \bar{z}^2 e^{-2i\omega t}) \quad (B2)$$

Two types of damping of the rotor system are assumed to exist: (1) damping in the rotor supports which is proportional to the translational velocity of the rotor hub and (2) damping of the rotation of the blades about the drag hinges. The damping dissipation function is then

$$F = \frac{B}{2} [z \dot{\bar{z}} + \omega^2 z \bar{z} + i\omega (z \dot{\bar{z}} - \bar{z} \dot{z})] + \frac{B_\beta}{b^2} (\dot{\theta}_0^2 + \dot{\theta}_1^2) \quad (B3)$$

where B is the damping force per unit velocity of rotor-hub displacements and B_β is the damping torque per unit angular velocity of blade motion about the drag hinge.

By using the Lagrangian form of the equations of motion

$$\frac{d}{dt} \left(\frac{\partial T}{\partial \dot{x}} \right) - \frac{\partial T}{\partial x} + \frac{\partial F}{\partial \dot{x}} + \frac{\partial V}{\partial x} = 0 \quad (B4)$$

and using as variables θ_0 , \bar{z} , z , and θ_1 , respectively, the following equations of motion for the rotor system are obtained:

$$(D^2 + D\lambda_\beta + \omega^2 \Lambda_1 + \Lambda_2) \theta_0 = 0 \quad (B5)$$

$$\left[(D + i\omega)^2 + \lambda(D + i\omega) + \frac{K}{M} \right] z - \frac{\Delta K}{M} \bar{z} e^{-2i\omega t} + i\mu(D + i\omega)^2 \theta_1 = 0 \quad (B6)$$

$$-\frac{\Delta K}{M} z e^{2i\omega t} + \left[(D - i\omega)^2 + \lambda(D - i\omega) + \frac{K}{M} \right] \bar{z} - i\mu(D - i\omega)^2 \theta_1 = 0 \quad (B7)$$

$$(D + i\omega)^2 z - (D - i\omega)^2 \bar{z} + 2i \left(1 + \frac{r^2}{b^2}\right) (D^2 + D\lambda_\beta + \Lambda_1 \omega^2 + \Lambda_2) \theta_1 = 0 \quad (B8)$$

where two additional combinations of parameters have been introduced, namely,

$$\lambda_\beta = \frac{B_\beta}{m_b b^2 \left(1 + \frac{r^2}{b^2}\right)}$$

and

$$\lambda = \frac{B}{M}$$

SPECIAL CASE—ZERO DAMPING

If damping is neglected, $\lambda_\beta = \lambda = 0$ and the equations of motion, (B5) to (B8), reduce to

$$(D^2 + \omega^2 \Lambda_1 + \Lambda_2) \theta_0 = 0 \quad (B9)$$

$$\left[(D + i\omega)^2 + \frac{K}{M} \right] z - \frac{\Delta K}{M} \bar{z} e^{-2i\omega t} + i\mu(D + i\omega)^2 \theta_1 = 0 \quad (B10)$$

$$-\frac{\Delta K}{M} z e^{2i\omega t} + \left[(D - i\omega)^2 + \frac{K}{M} \right] \bar{z} - i\mu(D - i\omega)^2 \theta_1 = 0 \quad (B11)$$

$$(D + i\omega)^2 z - (D - i\omega)^2 \bar{z} + 2i \left(1 + \frac{r^2}{b^2}\right) (D^2 + \Lambda_1 \omega^2 + \Lambda_2) \theta_1 = 0 \quad (B12)$$

which are the equations of motion (eqs. (7) to (10)) for the case treated in the present chapter.

SPECIAL CASE OF ISOTROPIC SUPPORTS

If $K_x = K_y$, then $\Delta K = 0$ and equations (B5) to (B8) reduce to

$$(D^2 + D\lambda_\beta + \omega^2 \Lambda_1 + \Lambda_2) \theta_0 = 0 \quad (B13)$$

$$\left[(D + i\omega)^2 + \lambda(D + i\omega) + \frac{K}{M} \right] z + i\mu(D + i\omega)^2 \theta_1 = 0 \quad (B14)$$

$$\left[(D - i\omega)^2 + \lambda(D - i\omega) + \frac{K}{M} \right] \bar{z} - i\mu(D - i\omega)^2 \theta_1 = 0 \quad (B15)$$

$$(D + i\omega)^2 z - (D - i\omega)^2 \bar{z} + 2i \left(1 + \frac{r^2}{b^2}\right) (D^2 + D\lambda_\beta + \Lambda_1 \omega^2 + \Lambda_2) \theta_1 = 0 \quad (B16)$$

Equation (B13) involves only the in-phase motion of the blades, can be solved separately, and will not be further considered here. If z and \bar{z} are expressed in the equivalent notations $x + iy$ and $x - iy$, respectively, and equations (B14) and (B15) are added together, equation (1) of chapter II is obtained. Equation (2) of chapter II is obtained by direct substitution and equation (3) is obtained by subtraction of equation (B15) from equation (B14). Thus the equations of motion for the case treated in chapter II as well as for the case treated in the present report are shown to be special cases of the general equations of motion, equations (B5) to (B8), for a rotor mounted on anisotropic supports with hub and blade-hinge damping.

APPENDIX C

DERIVATION OF THE CONVERGENCE FACTOR FOR $K(0)$

A convergence factor for $K(0)$ is found by finding a simpler function G_n that changes with n in nearly the same way as $K(0)_n$. Then, if G denotes $\lim_{n \rightarrow \infty} G_n$, the expression

$$\frac{K(0)_n G}{G_n}$$

for a given value of n is a better approximation to $K(0)$ than is $K(0)_n$ alone. A suitable form for G_n is found from a study of the behavior of $K(0)_n$ for large values of n .

The behavior of $K(0)_n$ is studied by first observing the behavior of $C_n(0)$ and $L_n(0)$ for large values of n and then inferring the behavior of $K(0)_n$ from the appropriate relation of equations (32). In the discussion of equations (22) it was shown that, as n becomes infinite, the ratio C_{n+1}/C_n approaches the value k (eq. (22a)). A closer approximation

to the value of this ratio can be written as

$$\frac{C_{n+1}(0)}{C_n(0)} = k \left(1 - \frac{P}{n} - \frac{Q}{4n^2} \right) \quad (C1)$$

where P and Q are constants to be determined.

Equations (19) become, for $\omega_a = 0$,

$$\left. \begin{aligned} C_{n+1}(0) &= \left[-1 + \frac{K/M}{(2n+1)^2 \omega^2} \right] D_n(0) - \Delta_3 \left(\frac{2n+1}{2n} \right)^2 E_n(0) \\ D_{n+1}(0) &= \left[-1 + \frac{\Delta_1 \omega^2 + \Delta_2}{(2n)^2 \omega^2} \right] E_n(0) - \Delta_3 \left(\frac{2n-1}{2n} \right)^2 C_n(0) \\ E_{n+1}(0) &= \left[-1 + \frac{K/M}{(2n-1)^2 \omega^2} \right] C_n(0) \end{aligned} \right\} (C2)$$

where the second term in the equation for $E_n(\omega_a)$ in equations

(19) has been neglected as being of higher order in powers of $1/n$ than the terms retained. Eliminating $E(0)$ and $D(0)$ from the equations (C2) results in

$$\frac{C_{n+1}(0)}{C_n(0)} = \left[-1 + \frac{K/M}{(2n+1)^2 \omega^2} \right] \left[-1 + \frac{\Delta_1 \omega^2 + \Delta_2}{(2n)^2 \omega^2} \right] \left[-1 + \frac{K/M}{(2n-1)^2 \omega^2} \right] - \Delta_3 \left\{ \left(\frac{2n-1}{2n} \right)^2 \left[-1 + \frac{K/M}{(2n+1)^2 \omega^2} \right] + \left(\frac{2n+1}{2n} \right)^2 \left[-1 + \frac{K/M}{(2n-1)^2 \omega^2} \right] \right\}$$

Upon expanding this expression into powers of $1/n$ and retaining terms up to and including those in $1/n^2$

$$\frac{C_{n+1}(0)}{C_n(0)} = -1 + 2\Delta_3 - \frac{1}{(2n)^2} \left[-\frac{2\frac{K}{M} + \Delta_1 \omega^2 + \Delta_2}{\omega^2} + 2\Delta_3 \left(\frac{K/M}{\omega^2} - 1 \right) \right] \quad (C3)$$

Comparing equation (C3) with equation (C1) results in

$$P = 0$$

$$Q = \frac{2\frac{K}{M}(1 - \Delta_3) + \Delta_1 \omega^2 + \Delta_2 + 2\Delta_3 \omega^2}{\omega^2(1 - 2\Delta_3)}$$

Similarly

$$\frac{L_{n+1}(0)}{L_n(0)} = k \left[1 - \frac{Q}{(2n)^2} \right]$$

Therefore, from equations (32)

$$\frac{K(0)_{n+1}}{K(0)_n} = \left(1 - \frac{Q}{4n^2} \right)^2$$

Hence, an approximate value of $K(0)$ can be obtained from

$$\begin{aligned} \frac{K(0)}{K(0)_n} &= \frac{K(0)_{n+1}}{K(0)_n} \frac{K(0)_{n+2}}{K(0)_{n+1}} \frac{K(0)_{n+3}}{K(0)_{n+2}} \dots \\ &\approx \prod_{j=n}^{\infty} \left(1 - \frac{Q}{4j^2} \right)^2 = \frac{\sin^2 \left(\frac{\pi \sqrt{Q}}{2} \right)}{\frac{\pi^2 Q}{4} \prod_{j=1}^{n-1} \left(1 - \frac{Q}{4j^2} \right)^2} \end{aligned} \quad (C4)$$

The right-hand side of equation (C4), which is seen to be of the form G/G_n , is a convergence factor. This convergence factor is the one used in equations (33).

where

$$\begin{aligned}
 a_{-3,-3} &= -1 + \frac{K_x/M}{(\omega_a - 3\omega)^2} & a_{0,0} &= -1 + \frac{\Delta_1\omega^2 + \Delta_2}{\omega_a^2} \\
 a_{-3,-2} &= \frac{\Delta_3}{2} & a_{0,1} &= \left(\frac{\omega_a + \omega}{\omega_a}\right)^2 \\
 a_{-2,-3} &= \left(\frac{\omega_a - 3\omega}{\omega_a - 2\omega}\right)^2 & a_{1,0} &= \frac{\Delta_3}{2} \\
 a_{-2,-2} &= -1 + \frac{\omega^2\Delta_1 + \Delta_2}{(\omega_a - 2\omega)^2} & a_{1,1} &= -1 + \frac{K_x/M}{(\omega_a + \omega)^2} \\
 a_{-2,-1} &= \left(\frac{\omega_a - \omega}{\omega_a - 2\omega}\right)^2 & a_{1,2} &= \frac{\Delta_3}{2} \\
 a_{-1,-2} &= \frac{\Delta_3}{2} & a_{2,1} &= \left(\frac{\omega_a + \omega}{\omega_a + 2\omega}\right)^2 \\
 a_{-1,-1} &= -1 + \frac{K_x/M}{(\omega_a - \omega)^2} & a_{2,2} &= -1 + \frac{\omega^2\Delta_1 + \Delta_2}{(\omega_a + 2\omega)^2} \\
 a_{-1,0} &= \frac{\Delta_3}{2} & a_{2,3} &= \frac{\omega_a + 3\omega}{(\omega_a + 2\omega)^2} \\
 a_{0,-1} &= \left(\frac{\omega_a - \omega}{\omega_a}\right)^2 & a_{3,2} &= \frac{\Delta_3}{2} \\
 & & a_{3,3} &= -1 + \frac{K_x/M}{(\omega_a + 3\omega)^2}
 \end{aligned}$$

The term $-1 + \frac{\omega^2\Delta_1 + \Delta_2}{\omega_a^2}$ will be taken as the origin of the determinant.

Define $\Delta_n(\omega_a)$ as the determinant of order $4n-1$ formed by taking a square array from $\Delta(\omega_a)$ centered on the origin. Then

$$\Delta(\omega_a) = \lim_{n \rightarrow \infty} \Delta_n(\omega_a)$$

Define auxiliary determinants from $\Delta_n(\omega_a)$ as follows:

- $C_n(\omega_a)$ determinant of order $2n-1$ consisting of the terms to the right of and below the origin term
- $D_n(\omega_a)$ determinant of order $2n-2$ obtained from $C_n(\omega_a)$ by omitting its last row and column
- $M_n(\omega_a)$ determinant of order $2n-2$ obtained from $C_n(\omega_a)$ by omitting its first row and column
- $N_n(\omega_a)$ determinant of order $2n-3$ obtained from $D_n(\omega_a)$ by omitting its first row and column

The determinants $C_n(\omega_a)$ and $D_n(\omega_a)$ satisfy the following recurrence relations:

$$\left. \begin{aligned}
 C_n(\omega_a) &= \left\{ -1 + \frac{K_x/M}{[\omega_a + (2n-1)\omega]^2} \right\} D_n(\omega_a) - \\
 &\quad \frac{\Delta_3}{2} \left[\frac{\omega_a + (2n-1)\omega}{\omega_a + (2n-2)\omega} \right]^2 C_{n-1}(\omega_a) \\
 D_n(\omega_a) &= \left\{ -1 + \frac{\omega^2\Delta_1 + \Delta_2}{[\omega_a + (2n-2)\omega]^2} \right\} C_{n-1}(\omega_a) - \\
 &\quad \frac{\Delta_3}{2} \left[\frac{\omega_a + (2n-3)\omega}{\omega_a + (2n-2)\omega} \right]^2 D_{n-1}(\omega_a)
 \end{aligned} \right\} \quad (D5)$$

The recurrence relations (eqs. (D5)) are also satisfied by $M_n(\omega_a)$ and $N_n(\omega_a)$, with M and N replacing C and D , respectively. The initial values are

$$C_1(\omega_a) = -1 + \frac{K_x/M}{(\omega_a + \omega)^2}$$

$$D_2(\omega_a) = \left[1 - \frac{K_x/M}{(\omega_a + \omega)^2} \right] \left[1 - \frac{\omega^2\Delta_1 + \Delta_2}{(\omega_a + 2\omega)^2} \right] - \frac{\Delta_3}{2} \left(\frac{\omega_a + \omega}{\omega_a + 2\omega} \right)^2$$

$$N_2(\omega_a) = -1 + \frac{\omega^2\Delta_1 + \Delta_2}{(\omega_a + 2\omega)^2}$$

$$M_2(\omega_a) = \left[1 - \frac{\omega^2\Delta_1 + \Delta_2}{(\omega_a + 2\omega)^2} \right] \left[1 - \frac{K_x/M}{(\omega_a + 3\omega)^2} \right] - \frac{\Delta_3}{2} \left(\frac{\omega_a + 3\omega}{\omega_a + 2\omega} \right)^2$$

Expanding $\Delta_n(\omega_a)$ in terms of the elements of the column containing the origin gives

$$\begin{aligned}
 \Delta_n(\omega_a) &= \left(-1 + \frac{\omega^2\Delta_1 + \Delta_2}{\omega_a^2} \right) C_n(-\omega_a) C_n(\omega_a) - \\
 &\quad \frac{\Delta_3}{2} \left[\left(\frac{\omega_a - \omega}{\omega_a} \right)^2 C_n(\omega_a) M_n(-\omega_a) - \left(\frac{\omega_a + \omega}{\omega_a} \right)^2 C_n(-\omega_a) M_n(\omega_a) \right]
 \end{aligned}$$

As n becomes infinite, or as ω_a becomes infinite, the recurrence relations (eqs. (D5)) approach

$$\left. \begin{aligned}
 C_n &= -D_n - \frac{\Delta_3}{2} C_{n-1} \\
 D_n &= -C_{n-1} - \frac{\Delta_3}{2} D_{n-1}
 \end{aligned} \right\} \quad (D6)$$

Equations (D6) are satisfied by a solution of the form

$$\left. \begin{aligned}
 C_n &= Ck^n \\
 D_n &= -C \left(k + \frac{\Delta_3}{2} \right) k^{n-1}
 \end{aligned} \right\} \quad (D7)$$

where k satisfies the equation

$$k^2 - (1 - \Delta_3)k + \frac{\Delta_3^2}{4} = 0 \quad (D8)$$

The larger root of equation (D8) will be denoted by k and the smaller root by k_1 . Although the complete solution of equation (D6) is of the form

$$C_n = Ck^n + C'k_1^n$$

for large values of n the term in k_1 becomes negligible compared with the term in k .

With the same values for k , M_n and N_n will have solutions similar to those of equations (D7). Thus as n becomes infinite $\Delta_n(\omega_a)$ will vary as the quantity k^{2n} .

Define the function

$$F(\omega_a) = \lim_{n \rightarrow \infty} F_n(\omega_a) = \lim_{n \rightarrow \infty} \frac{\Delta_n(\omega_a)}{k^{2n}}$$

The function $F(\omega_a)$ is periodic in ω_a of period 2ω , has roots

$\pm(\omega_{a_1} \pm 2s\omega)$, $\pm(\omega_{a_2} \pm 2s\omega)$, and second-order poles at $(\omega_a \pm s\omega)$ for all integral values of s . Furthermore, $F(\omega_a)$ approaches the limit

$$\begin{aligned} E &= \lim_{\omega_a \rightarrow \infty} F(\omega_a) = \lim_{n \rightarrow \infty} F_n(\infty) \\ &= \lim_{n \rightarrow \infty} \frac{C_{2n}(\infty)}{k^{2n}} = \frac{k^2}{k_1^2 - k^2} \end{aligned}$$

as ω_a becomes infinite in a direction other than along the real axis.

Form the function

$$J(\omega_a) = F(\omega_a) \frac{\sin^2\left(\frac{\pi\omega_a}{\omega}\right)}{\left[\sin^2\left(\frac{\pi\omega_a}{2\omega}\right) - \sin^2\left(\frac{\pi\omega_{a_1}}{2\omega}\right)\right] \left[\sin^2\left(\frac{\pi\omega_a}{2\omega}\right) - \sin^2\left(\frac{\pi\omega_{a_2}}{2\omega}\right)\right]} \tag{D9}$$

The function $J(\omega_a)$ is an analytic function of ω_a everywhere. Hence, by Liouville's theorem, $J(\omega_a)$ is a constant. By letting $\omega_a \rightarrow +\infty$ along the imaginary axis, it is seen that $J(\omega_a) = -4E$.

Substituting $-4E$ for $J(\omega_a)$ into equation (D9) results in

$$\begin{aligned} \lim_{n \rightarrow \infty} \frac{\Delta_n(\omega_a)}{k^{2n}} &= F(\omega_a) \\ &= -4E \frac{\left[\sin^2\left(\frac{\pi\omega_a}{2\omega}\right) - \sin^2\left(\frac{\pi\omega_{a_1}}{2\omega}\right)\right] \left[\sin^2\left(\frac{\pi\omega_a}{2\omega}\right) - \sin^2\left(\frac{\pi\omega_{a_2}}{2\omega}\right)\right]}{\sin^2\left(\frac{\pi\omega_a}{\omega}\right)} \end{aligned}$$

Introducing K functions defined similarly to those used for the case $K_y = 0$ gives

$$\left. \begin{aligned} K_1 &= \sin^2\left(\frac{\pi\omega_{a_1}}{2\omega}\right) \sin^2\left(\frac{\pi\omega_{a_2}}{2\omega}\right) \\ &= \lim_{\omega_a \rightarrow 0} \left[\frac{\sin^2\left(\frac{\pi\omega_a}{\omega}\right) F(\omega_a)}{-4E} \right] \\ K_2 &= \cos^2\left(\frac{\pi\omega_{a_1}}{2\omega}\right) \cos^2\left(\frac{\pi\omega_{a_2}}{2\omega}\right) \\ &= \lim_{\omega_a \rightarrow \omega} \left[\frac{\sin^2\left(\frac{\pi\omega_a}{2\omega}\right) F(\omega_a)}{-4E} \right] \end{aligned} \right\} \tag{D10}$$

Carrying out the limit processes indicated in equations (D10) gives

$$\begin{aligned} K_1 &= \lim_{n \rightarrow \infty} K_{1n} \\ &= \lim_{n \rightarrow \infty} \left[\frac{\pi^2(\omega^2 \Delta_1 + \Delta_2) C_n^2(0) - \Delta_3 \pi^2 \omega^2 C_n(0) N_n(0)}{-4\omega^2 C_{2n}(\infty)} \right] \\ K_2 &= \lim_{n \rightarrow \infty} K_{2n} \\ &= \lim_{n \rightarrow \infty} \left[\frac{\pi^2 \frac{K_2}{M} k N_n^2(-\omega)}{-4\omega^2 C_{2n}(\infty)} \right] \end{aligned}$$

Finally, upon introducing appropriate convergence factors, the following quantities needed in equations (36) are obtained:

$$\begin{aligned} K_1 &= \lim_{n \rightarrow \infty} \left[\frac{K_{1n} \sin^2\left(\frac{\pi R}{2}\right)}{\frac{\pi^2 R^2}{4} \prod_{j=1}^n \left(1 - \frac{R^2}{4j^2}\right)} \right] \\ K_2 &= \lim_{n \rightarrow \infty} \left\{ \frac{K_{2n} \cos^2\left(\frac{\pi R}{2}\right)}{\prod_{j=1}^n \left[1 - \frac{R^2}{(2j-1)^2}\right]} \right\} \end{aligned}$$

where

$$R^2 = \frac{K_2}{M} + \omega^2 \Delta_1 + \Delta_2 + \omega^2(1 + k_1 - k) / \omega^2(k - k_1)$$

REFERENCES

1. Foote, W. R., Poritsky, H., and Slade, J. J., Jr.: Critical Speeds of a Rotor With Unequal Shaft Flexibilities, Mounted in Bearings of Unequal Flexibility—I. Jour. Appl. Mech., vol. 10, no. 2, June 1943, pp. A-77—A-84.
2. Den Hartog, J. P.: Mechanical Vibrations. Second ed., McGraw-Hill Book Co., Inc., 1940, pp. 380-396.
3. Whittaker, E. T., and Watson, G. N.: A Course of Modern Analysis. Fourth ed., Cambridge Univ. Press (London), 1927. (Reprinted 1940.)

