

REPORT 1358

ON FLOW OF ELECTRICALLY CONDUCTING FLUIDS OVER A FLAT PLATE IN THE PRESENCE OF A TRANSVERSE MAGNETIC FIELD¹

By VERNON J. ROSSOW

SUMMARY

The use of a magnetic field to control the motion of electrically conducting fluids is studied. The incompressible boundary-layer solutions are found for flow over a flat plate when the magnetic field is fixed relative to the plate or to the fluid. The equations are integrated numerically for the effect of the transverse magnetic field on the velocity and temperature profiles, and hence, the skin friction and rate of heat transfer.

It is concluded that the skin friction and the heat-transfer rate are reduced when the transverse magnetic field is fixed relative to the plate and increased when fixed relative to the fluid. The total drag is increased in all of the cases studied.

INTRODUCTION

It has been said that a fluid at a very high temperature is like a universal solvent which cannot be contained. A possible method of containing this fluid is suggested when it is noted that at such a high temperature it would surely contain ions and quite probably also free electrons. The fluid would then be an electrical conductor. The invisible hand of electrical and magnetic fields can then be used to induce forces on the fluid such that it is prevented from coming in direct contact with a wall which it would dissolve.

A somewhat similar technique has been in use for some time in the metal purification industry. It employs a high-frequency magnetic field which causes eddy currents in a lump of molten metal which in turn react with the imposed magnetic field. The metal is thereby suspended in space if the imposed magnetic field is made strong enough.

Another example is the so-called "perhapsatron" described briefly in reference 1. A gas in a doughnut shaped container is heated to a high temperature by an electrical current discharge. Through the use of the interaction of the resulting ion current and a magnetic field, the hot gas is prevented from coming in contact with the surface of the vessel. An application of similar principles was used in thermonuclear fusion experiments in the Soviet Union. The techniques and results described very briefly in reference 2 indicate that it was possible to keep the hot fluid from the walls and to concentrate the hot gases quickly so as to generate a focusing shock wave.

These examples indicate the possibilities which may be realized through the use of a magnetic-field force on a flowing conducting fluid. A number of situations exist in aerodynamics wherein a magnetic or electrical field might be used to alleviate high convective heat-transfer rates to a wall. Such problems arise in the flow of air in the boundary layer and in the vicinity of stagnation regions of an aircraft moving at very high speeds. If the velocity is high enough the air is ionized and, therefore, electrically conducting. See, for example, references 3 and 4. Other examples are those associated with the flow of the combustion products (which are hot and generally electrically conducting, refs. 5 through 7) in the propulsion units of aircraft.

The extent to which a given heating problem can be alleviated is as yet difficult to determine. It would be well if a few theoretical results were available to evaluate the effect of a magnetic field on the drag and heat-transfer rate. An attempt to include all the aerodynamic features of the flow of air over or inside an aircraft plus the magneto-hydrodynamic (or more correctly, magneto-aerodynamic) effects would render the problem so complicated as to make its solution difficult if not impossible. It is felt that a few simple basic theoretical solutions would point out the advantages or disadvantages and yield a rough estimate of the various quantities entering the problem. It is the purpose of this report to present the results of several such solutions which, it is hoped, will extend the information already available so that such estimates can be made. Several applications of the results are indicated.

PRINCIPAL SYMBOLS

\vec{b}, B	magnetic induction, lines/sq in.
c_f	local skin-friction coefficient
C_p	heat capacity of air at constant pressure, Btu/slug °F
\vec{E}	electric field intensity, volts/in.
E	total energy, $C_p T + \frac{u^2}{2}$
erf	error function
$erfc$	complementary error function, $1 - erf$
f_0	dimensionless Blasius boundary-layer stream function

¹ Supersedes NACA TN 3971 by Vernon J. Rossow, 1957.

$f_1, f_2, f_3 \dots$	dimensionless stream function, equation (26)
F	force, lb
h	local heat-transfer coefficient, Btu/sec ft ² °F
\vec{H}	magnetic intensity, $\frac{\vec{B}}{\mu}$, (ampere)(turns)/in.
i	electric current, amp
\vec{j}	electric current density in the fluid, amp/sq in.
\vec{J}	electric current density associated with generation of magnetic field, amp/sq in.
k	thermal conductivity, Btu/sec ft ² °F/ft
l	characteristic length
m	magnetic parameter, $\frac{\sigma B_o^2}{\rho u_\infty}$, per in.
m_1	$\frac{\sigma B_o^2}{\rho}$, per sec
\overline{M}	magnetic Hartmann number, $\sqrt{\frac{\sigma B^2 l^2}{\mu}}$
p	pressure, lb/sq in.
Q	$\frac{B^2 \sigma l}{\rho U}$
Re	Reynolds number
s	Laplace transform variable
T	temperature, °R
u, v, w	velocity components in x, y, z directions
\vec{u}	Laplace transform of velocity u (see eq. (14))
\vec{U}	velocity, ft/sec
x, y, z	coordinate axes, x aligned with free stream
η	$y \sqrt{\frac{u_\infty}{\nu x}}$
θ	excess charge density, coulomb/cu in.
λ	magnetic viscosity, $\frac{1}{4\pi\sigma\mu}$
μ	coefficient of viscosity, slugs/ft sec
$\overline{\mu}$	magnetic permeability, (volt)(second)/(ampere)(inch)
ν	kinematic viscosity, $\frac{\mu}{\rho}$, ft ² /sec
ξ	x
ρ	density of fluid, slugs/cu ft
σ	conductivity, mhos/in.
τ	shear stress, lb/sq in.
ψ	stream function
SUBSCRIPTS	
o	basic quantity
∞	free stream
B	magnetic induction
e	electron
w	at plate, $\eta=y=0$
SUPERSCRIPTS	
$\vec{\quad}$	vector quantity
$(\quad)', (\quad)'' , (\quad)'''$	derivatives

HISTORICAL REVIEW OF MAGNETO-HYDRODYNAMICS

The earliest known published works treating a problem in the flow of an electrically conducting fluid through a magnetic field are those of Hartmann and of Hartmann and Lazarus in references 8 and 9. Since that time a number of theoretical and experimental studies have been carried out. Some of these pertain to the flow of a conducting fluid but a larger number relate to the dynamics of ionized clouds or stars. No attempt will be made here to include a complete discussion of the latter group. However, much can be learned by studying the papers on the flow of conducting fluids. These papers will be divided into several groups according to the type of problem treated.

1. Flow in a channel (refs. 8 through 19).
 2. Flow about bodies of various shapes (refs. 20 through 22).
 3. Related papers on astronomy (refs. 23 through 26).
- The various papers will be reviewed briefly on a group basis and reference to particular papers given only in special instances.

FLOW IN CHANNEL

Following his invention of the electromagnetic pump² in 1918, Hartmann, reference 8, developed equations which describe the steady-state flow inside a channel in the presence of a magnetic field or a magnetic and electrical field. Interest was stimulated in problems of this type when it was found in reference 9 that a turbulent stream could be stabilized to the extent that it could be forced to return to a laminar flow. Such a sequence of events is opposite to the usual form of transition when a magnetic field is not present. Further investigations by other authors, references 10 through 19, substantiated these results and led to the introduction of terms such as "magnetic viscosity," $\lambda = \frac{1}{4\pi\sigma\mu}$, "magnetic Hartmann number," $\overline{M} = Bl \sqrt{\frac{\sigma}{\mu}}$ and $Q = \frac{\sigma B^2 l}{\rho U}$.

A rigidity of the fluid is brought about by a coplanar magnetic field so that stabilization is achieved because the conducting fluid experiences a force which resists the motion across the magnetic lines of force (ref. 13). For example, if the main fluid flow direction is parallel to the magnetic lines of force, no interaction takes place unless some deviation or instability arises. In this event, a restraining force will be induced which is proportional and opposite to the velocity component perpendicular to the lines of force, tending to damp out the initial instability.

When the magnetic field is perpendicular to the flow direction, a change is brought about in the velocity distribution. This may make the fluid flow more stable or unstable to transition to turbulence. In the case of flow of an electrically conducting fluid through a transverse magnetic field in a two-dimensional channel (refs. 9 and 14), the change in the velocity profile had a very favorable effect on transition. Such is not always expected to be the case in other flow problems.

² Electromagnetic pumps are used in atomic energy plants to transfer radioactive solutions from one place to another (e. g., see p. 32 of Atomic Power—a Scientific American book, Simon and Schuster Inc., New York, 1955).

These two techniques which increase the stability of fluid flowing in a two-dimensional channel were studied theoretically in references 13 and 14. The transition boundaries are given in graphical form for a range of the magnetic parameter. It was observed that a considerable increase in laminar run could be achieved at the higher values of the magnetic parameter.

FLOW ABOUT BODIES OF VARIOUS SHAPES

The papers describing the external flow of a conducting fluid about bodies are small in number. The three references listed, 20 through 22, describe the flow of a conducting fluid around a circular cylinder and a sphere in the presence of a magnetic field; the third paper treats the stability of the flow between rotating cylinders. Streamlines are shown in the first two cases and the stability boundary for the latter case. Problems in this category are naturally more difficult than the unidirectional channel flow problems discussed in the previous section.

RELATED PAPERS ON ASTRONOMY

A need for understanding the motion of electrically conducting fluids (ionized clouds) has been felt by astronomers for some time. The dimensions and quantities considered are generally not reproducible in the laboratory or in the earth's atmosphere; however, some of the equations and results may be applied to aerodynamic problems.

In reference 23, Batchelor investigated the possibility of spontaneous magnetic fields arising in a conducting medium as a result of turbulence. He found that unless $4\pi\bar{\mu}\sigma\nu > 1$ such fields cannot occur. In all foreseeable problems in aerodynamics $4\pi\bar{\mu}\sigma\nu$ is many orders of magnitude less than 1, ruling out spontaneous magnetic fields in a fluid due to turbulence.

The manner and velocity at which pressure waves are propagated in an ionized fluid and other cosmic problems are treated in references 24 through 26. The results of these studies on wave propagation may be useful in studying interference problems on high-velocity aircraft.

MAGNETO-AERODYNAMIC EQUATIONS

The equations which describe the flow of an electrically conducting fluid in the presence of magnetic and electrical fields will now be discussed. The equations are simplified to the extent that the flow is assumed to be incompressible and to have constant properties (C_p, μ, k) throughout the flow field. In all cases except one, the electrical conductivity of the fluid is assumed to be constant.

MOMENTUM-TRANSPORT EQUATIONS

The momentum-transport equations for the flow of a viscous incompressible fluid consist of a combination of the force terms arising from the excess charge density θ , and induced magnetic effect due to the motion of the conducting fluid through magnetic lines of force (see, e. g., refs. 23 and 27) and the usual Navier-Stokes relations (see, e. g., ref. 28). In equation form, these force terms are,

$$\vec{F} = \theta\vec{E} + \vec{j} \times \vec{B}$$

where the term $\theta\vec{E}$ results from the electrostatic force on the excess charges due to the presence of an imposed electric field \vec{E} . The second term describes the force on the fluid due to the interaction of the electric current, \vec{j} , in the fluid and the magnetic induction \vec{B} . The differential equation can be written in vector notation as

$$\frac{D\vec{U}}{Dt} - \frac{\theta\vec{E}}{\rho} - \frac{\bar{\mu}}{\rho} \vec{j} \times \vec{H} + \frac{1}{\rho} \text{grad } p = \nu \nabla^2 \vec{U} \tag{1}$$

where ρ is the fluid density, θ is the excess charge density, and $\bar{\mu}$ is the magnetic permeability. The substantial derivative D/Dt is associated with the use of spatial coordinates. A simplified version of Maxwell's equations appropriate for the present problem is

$$\text{div } \vec{H} = 0; \text{div } \vec{J} = 0; \bar{\mu}\vec{H} = \vec{B} \tag{2a}$$

$$\text{curl } \vec{H} = 4\pi\vec{J} \tag{2b}$$

A reduced form of the generalized Ohm's law is, from reference 29,

$$\vec{j} = \sigma(\vec{E} + \bar{\mu}\vec{U} \times \vec{H}) \tag{2c}$$

The more complete form given as equation 2-22 in reference 29 includes additional terms accounting for gravity and pressure gradient effects. Both of these factors will be assumed negligible in this analysis. It will also be assumed that the conductivity, σ , does not have directional properties.

The continuity equation is

$$\text{div } \vec{U} = 0 \tag{3}$$

Equation (2b) expresses the relation between the magnetic intensity \vec{H} and the total electric current density \vec{J} . The distinction between the current densities \vec{j} and \vec{J} lies in their location and action. Consider first the situation when the fluid is stationary and the electric field intensity \vec{E} is zero. The current density in the fluid is then zero. The magnetic field strength \vec{H}_0 or magnetic induction $\vec{B}_0 = \bar{\mu}\vec{H}_0$ is a result of an electric current \vec{J}_0 outside of the fluid. The current density \vec{J}_0 could be thought of as an electric current in a coil or electromagnet outside the flow region producing a magnetic field of a given number of lines of force per unit area. The relation between \vec{J}_0 and \vec{H}_0 is given by equation (2b). The basic magnetic field strength will be designated as \vec{H}_0 .

When a conducting fluid moves through the magnetic lines of force, \vec{B}_0 , the positive and negative charges are each accelerated in such a way that their average motion gives rise to an electric current $\vec{j} = \sigma\vec{U} \times \vec{B}$, where $\vec{B} = \vec{B}_0 + \vec{b}$. The quantity \vec{b} is the magnetic induction resulting from the electric current \vec{j} in the fluid. In this analysis \vec{b} will be con-

sidered as a perturbation on the basic field strength and negligible in comparison with \vec{B}_0 ; that is, from equation (2b),

$$\text{curl } (\vec{B}_0 + \vec{b}) = 4\pi\bar{\mu}(\vec{J}_0 + \vec{j}) = 4\pi\bar{\mu}\vec{J}$$

or

$$\text{curl } \vec{B}_0 = 4\pi\bar{\mu}\vec{J}_0$$

$$\text{curl } \vec{b} = 4\pi\bar{\mu}\vec{j}$$

where $\vec{B}_0 \gg \vec{b}$.

If an electric potential \vec{E} were to be imposed across the flow field, the current density would be changed by $\vec{j} = \sigma\vec{E}$. However, the boundary conditions will be taken so that the impressed potential, \vec{E} , is zero. Therefore, $\vec{j} = \sigma\vec{U} \times \vec{B}_0$; that is, the electric current is proportional to the voltage generated by the relative motion of the fluid and magnetic field.

The fluid is assumed to be ionized and thereby an electrical conductor. However, within any small but finite volume the number of particles with positive and negative charges are nearly equal. The total excess charge, θ , in this small but finite volume will be taken as equal to zero. It has been shown in reference 17 that a very small increase in viscosity is realized due to the increased ordered-migration velocities of positive and negative ions in the presence of the electric field. This effect will be neglected and the electrostatic force term, $\theta\vec{E}$ will be assumed to be identically zero.

The induced electromagnetic force term, $\vec{j} \times \vec{B}_0$ will now be related to the local velocity vector. The procedure used in references 10, 19, and 22 which results in the magnetic parameter $\frac{\bar{\mu}H^2}{\rho U^2}$ (ratio of electromagnetic and inertia forces)

and the magnetic viscosity $\lambda = \frac{1}{4\pi\sigma\bar{\mu}}$ will not be used. Instead a procedure will be followed which will lead to the magnetic parameter, $Q = \frac{\sigma B_0^2 l}{\rho U}$, used by references 7, 9, 11, 12, and 13.

A relation between $\vec{j} \times \vec{B}_0$ and the velocity is obtained from equation (2). It will be assumed that:

- (1) Magnetic field lines are perpendicular to free-stream velocity.
- (2) Permeability $\bar{\mu}$ is constant throughout the fluid.
- (3) The assumptions already made are that the excess charge density θ and imposed electric field intensity \vec{E} are assumed to be zero.

(4) Induced magnetic field \vec{b} is negligible, linearizing the induced magnetic force term.

The first assumption is not highly restrictive since the perpendicular component of the magnetic field is the only part contributing a force which will change the laminar velocity profile. The other assumptions are reasonable physical approximations.

If these assumptions are used together with equation (2c), the induced magnetic force term becomes

$$-\frac{\vec{j} \times \vec{B}_0}{\rho} = -\frac{\sigma}{\rho} (\vec{U} \times \vec{B}_0) \times \vec{B}_0 \quad (5)$$

From vector relations,

$$-\frac{\vec{j} \times \vec{B}_0}{\rho} = -\frac{\sigma}{\rho} (\vec{U} \times \vec{B}_0) \times \vec{B}_0 = \frac{\sigma}{\rho} [\vec{U} (\vec{B}_0 \cdot \vec{B}_0) - \vec{B}_0 (\vec{B}_0 \cdot \vec{U})]$$

However, it has been assumed that \vec{B}_0 is perpendicular to the free-stream velocity \vec{U}_∞ (assumption (1)). In the problems treated, the local velocity direction differs a negligible amount from the free-stream direction so that $\vec{B}_0 \cdot \vec{U} = 0$ and the linearized magneto-hydrodynamic force term becomes

$$-\frac{\vec{j} \times \vec{B}_0}{\rho} = \frac{\sigma B_0^2}{\rho} \vec{U} = m U_\infty \vec{U} \quad (6)$$

The parameter m is related to the viscous Reynolds number and the Hartmann number of references 8 through 12 by

$$m l = \frac{\sigma B_0^2 l}{\rho U_\infty} = \frac{\sigma B_0^2 l^2}{\mu} \frac{1}{\rho U_\infty l} = \frac{\bar{M}^2}{Re}$$

Equation (1) may then be written as

$$\frac{D\vec{U}}{Dt} + \frac{\sigma B_0^2}{\rho} \vec{U} + \frac{1}{\rho} \text{grad } p = \nu \nabla^2 \vec{U} \quad (7)$$

In the development of equation (7), it was assumed that the velocity of the magnetic field is zero. Since only the inductive force is being considered, the second term becomes $\frac{\sigma B_0^2}{\rho} (\vec{U} - \vec{U}_B)$ for a magnetic field in uniform translation, where \vec{U}_B is the velocity of the magnetic field.

When electrical currents flow in a plasma it is well to define the conditions at the solid boundaries of the flow field. The problems treated are assumed to be two-dimensional with the electric current flowing from and to infinity parallel to a flat plate and perpendicular to the stream direction. The configuration may also be thought to consist of flow in a wide channel with the two side walls as conductors connected by a conductor of negligible resistance located outside of the influence of the flow field. The flow in the middle of such a channel should approximate the two-dimensional type of flow being analyzed. Such phenomena as charge accumulation and boundary effects at the walls will be assumed negligible.

THERMAL ENERGY TRANSPORT EQUATION

The differential equation describing the relationship between the convection and conduction of thermal energy and the work done on an electrically conducting fluid in the presence of a magnetic field is found by considering the

³ From electric motor equations, it can be shown that

$$\sigma B_0^2 = \frac{\text{force}}{l \times \text{velocity}}$$

and therefore

$$\frac{\sigma B_0^2}{\rho U_\infty} = \left(\frac{\bar{\mu} H_0^2}{\rho U_\infty^2} \right) (\sigma \bar{\mu} U_\infty l) = \left(\frac{\text{magnetic pressure}}{\text{dynamic pressure}} \right) \left(\frac{\text{magnetic Reynolds number}}{\text{number}} \right)$$

energy entering and leaving an elementary cubic box. The result is given by

$$\rho C_p \frac{DT}{Dt} = k \nabla^2 T + \frac{j^2}{\sigma} + \frac{Dp}{Dt} + \mu \left\{ 2 \left[\left(\frac{\partial u}{\partial x} \right)^2 + \left(\frac{\partial v}{\partial y} \right)^2 + \left(\frac{\partial w}{\partial z} \right)^2 \right] + \left(\frac{\partial v}{\partial x} + \frac{\partial u}{\partial y} \right)^2 + \left(\frac{\partial w}{\partial y} + \frac{\partial v}{\partial z} \right)^2 + \left(\frac{\partial u}{\partial z} + \frac{\partial w}{\partial x} \right)^2 \right\} \quad (8)$$

The derivation of equation (8), with the exception of the second term on the right of the equal sign, can be found, for example, in reference 28. The term on the left of the equal sign takes account of the enthalpy transported by the motion of the fluid or by convection. The first term on the right represents heat conducted from one element of fluid to the next by molecular motion. The expression, j^2/σ , is the heat added by the electrical current produced by the motion of the fluid through magnetic lines of force or by an imposed electrical field (see eq. (2c)). The remaining terms arise when work is done on the fluid by either pressure or shear forces. The symbol D/Dt is the substantial derivative of the particular quantity and ∇^2 denotes the Laplacian.

If the general expression for the electric current density, as given by equation (2c), is inserted into the expression for the heat added by electrical means, the result is

$$\frac{j^2}{\sigma} = \sigma (\vec{E} + \vec{U} \times \vec{B})^2 \quad (9)$$

It has been assumed that the electric field \vec{E} is zero and that the magnetic field lines are perpendicular to the free-stream direction. To a good approximation in the problems to be considered, equation (9) can then be written as

$$\frac{j^2}{\sigma} = \sigma U^2 B_0^2 \quad (10)$$

where U^2 must be written as $(U - U_B)^2$ when relative motion exists between the magnetic field and the plate. Equation (8) is then

$$\rho C_p \frac{DT}{Dt} = k \nabla^2 T + \sigma U^2 B_0^2 + \frac{Dp}{Dt} + \mu \left\{ 2 \left[\left(\frac{\partial u}{\partial x} \right)^2 + \left(\frac{\partial v}{\partial y} \right)^2 + \left(\frac{\partial w}{\partial z} \right)^2 \right] + \left(\frac{\partial v}{\partial x} + \frac{\partial u}{\partial y} \right)^2 + \left(\frac{\partial w}{\partial y} + \frac{\partial v}{\partial z} \right)^2 + \left(\frac{\partial u}{\partial z} + \frac{\partial w}{\partial x} \right)^2 \right\} \quad (11)$$

IMPULSIVE MOTION OF A FLAT PLATE

The impulsive motion of an infinite flat plate⁴ in a viscous fluid serves as a model for the boundary layer on a semi-infinite flat plate. The advantages of working the problem of the impulsive motion of a flat plate are that it is simple enough to yield a result in closed form and suggests the proper choice of parameters to be used on the more complicated problem of a semi-infinite flat plate.

The velocity profiles will be found for two cases. In the first it will be assumed that the magnetic lines of force are fixed relative to the plate, and the second relative to the fluid. In both cases the fluid is of uniform density and

⁴ This problem is often referred to as the "Rayleigh problem" when the fluid is incompressible and nonconducting.

viscosity, and has the same electrical conductivity throughout. A third case, in which the magnetic field is fixed on the plate and a compensating pressure gradient exists in the fluid, will be shown to be equivalent to the case wherein the magnetic field is fixed relative to the fluid. The problem wherein the fluid conductivity varies will not be considered. The fluid and plate will be assumed to be initially at rest. At time $t=0$, the plate will move impulsively with a given velocity.

MAGNETIC FIELD FIXED RELATIVE TO THE PLATE

At time $t < 0$, the fluid, plate, and magnetic field are assumed to be everywhere stationary. At time $t=0$ and for all later times the plate and magnetic field are moving at velocity $u = u_\infty$ (fig. 1). The problem is to find the velocity-time history of the fluid.

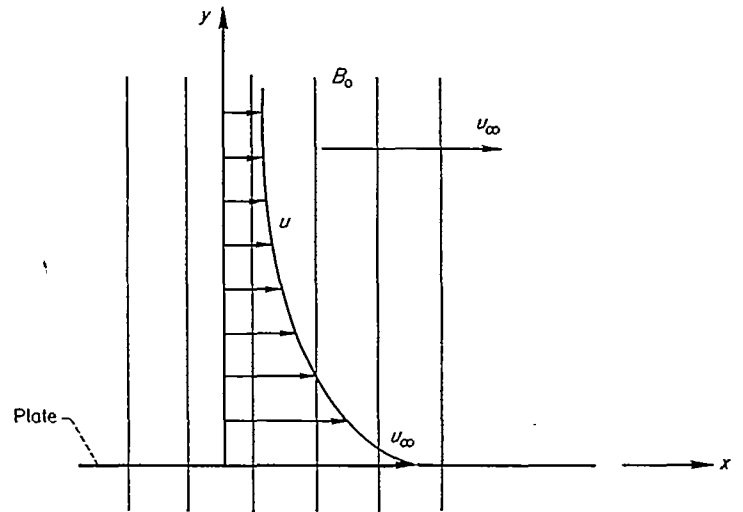

FIGURE 1.—Flat plate moving impulsively through a fluid in the presence of a transverse magnetic field.

The velocity in a given $y = \text{constant}$ plane does not change with x . It can then be reasoned that the vertical, v , and transverse, w , velocities are zero or negligible together with the pressure gradients in all directions. Equation (7) then reduces to

$$\frac{\partial u}{\partial t} + \frac{\sigma B_0^2}{\rho} u = \nu \frac{\partial^2 u}{\partial y^2} \quad (12)$$

Since the magnetic field is moving and the fluid is initially at rest the relative motion must be accounted for. Equation (12) is then

$$\frac{\partial u}{\partial t} + \frac{\sigma B_0^2}{\rho} (u - u_\infty) = \nu \frac{\partial^2 u}{\partial y^2} \quad (13)$$

The boundary conditions are

$$u = u_\infty, \quad y = 0, \quad t \geq 0$$

$$u = 0, \quad y > 0, \quad t = 0$$

The Laplace transform of the velocity u is defined as

$$\bar{u} = \int_0^\infty e^{-st} u dt \quad (14)$$

Applying the Laplace transformation (see, e. g., refs. 30 and 31) to the first term in equation (13) gives

$$L\left(\frac{\partial u}{\partial t}\right) = \int_0^\infty e^{-st} \frac{\partial u}{\partial t} dt = +ue^{-st} \Big|_0^\infty + s \int_0^\infty e^{-st} u dt = s\bar{u}$$

If the other terms of equation (13) are treated similarly, the transformed equation is

$$s\bar{u} = \nu \frac{d^2 \bar{u}}{dy^2} + \frac{m_1 u_\infty}{s} - m_1 \bar{u}$$

or

$$\frac{d^2 \bar{u}}{dy^2} = \bar{u} \left(\frac{s+m_1}{\nu} \right) - \frac{m_1 u_\infty}{\nu s} \tag{15}$$

The solution to equation (15) is the sum of the solution of the homogeneous equation plus the particular solution, that is,

$$\bar{u} = \frac{m_1 u_\infty}{s(s+m_1)} + \frac{m_1 u_\infty}{s(s+m_1)} \left[C_1(s) e^{-y\sqrt{\frac{s+m_1}{\nu}}} + C_2 e^{+y\sqrt{\frac{s+m_1}{\nu}}} \right]$$

The constant C_2 is chosen equal to zero to fit the boundary condition that \bar{u} must be finite at $y = \infty$. The integration constant $C_1(s)$ is found from the boundary condition at $y=0$; that is, on the plate

$$u_{y=0} = u_\infty$$

The Laplace transform of u_∞ is u_∞/s . Therefore

$$C_1(s) = \frac{s}{m_1}$$

and

$$\bar{u} = \frac{m_1 u_\infty}{s(s+m_1)} + \frac{u_\infty}{s+m_1} e^{-y\sqrt{\frac{s+m_1}{\nu}}} \tag{16}$$

Equation (16) can be inverted with the aid of reference 30. Combining several terms gives

$$u = u_\infty \left(1 - e^{-m_1 t} \operatorname{erf} \frac{y}{2\sqrt{\nu t}} \right) \tag{17}$$

The symbol *erf* denotes the error function of the argument. The error function is discussed in reference 31 and tabulated extensively in reference 32. Typical velocity profiles are shown in figure 2 (a). If m_1 is set equal to zero, equation (17) reduces to the result for the Rayleigh problem; that is,

$$u = u_\infty \left(1 - \operatorname{erf} \frac{y}{2\sqrt{\nu t}} \right)$$

The velocity is a function of $y/2\sqrt{\nu t}$ only and therefore a single profile suffices. However, when a magnetic field is acting on the fluid, the velocity profiles are not similar because they change with time according to $e^{-m_1 t}$. The fluid at infinity is accelerated by the magnetic field so that the entire mass of fluid is accelerated by the magnetic field. It is, in fact, accelerated more rapidly than when the only force is the viscous action between layers.

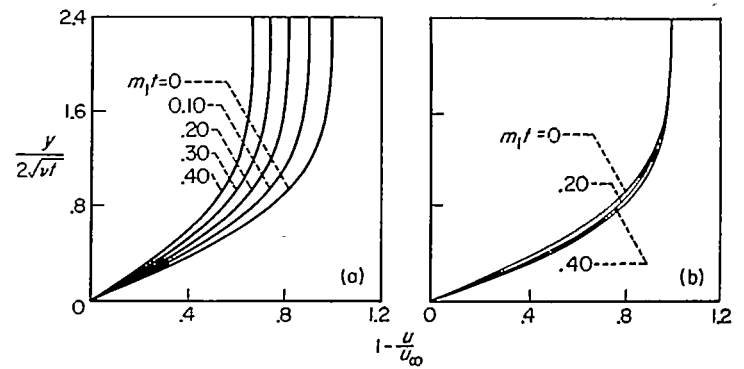

(a) Magnetic field fixed relative to plate. (b) Magnetic field fixed relative to fluid.

FIGURE 2.—Boundary-layer velocity profiles on a flat plate set into motion impulsively.

The skin-friction coefficient is expressed as

$$c_f = \frac{\mu(\partial u / \partial y)|_{y=0}}{\rho u_\infty^2 / 2} \tag{18}$$

so that, from equation (17),

$$c_f = \frac{2\nu}{u_\infty \sqrt{\pi \nu t}} e^{-m_1 t} \tag{19a}$$

Values of c_f are shown in graphical form in figure 3. When m_1 is zero, equation (19a) reduces to the skin friction for the nonelectromagnetic Rayleigh problem.

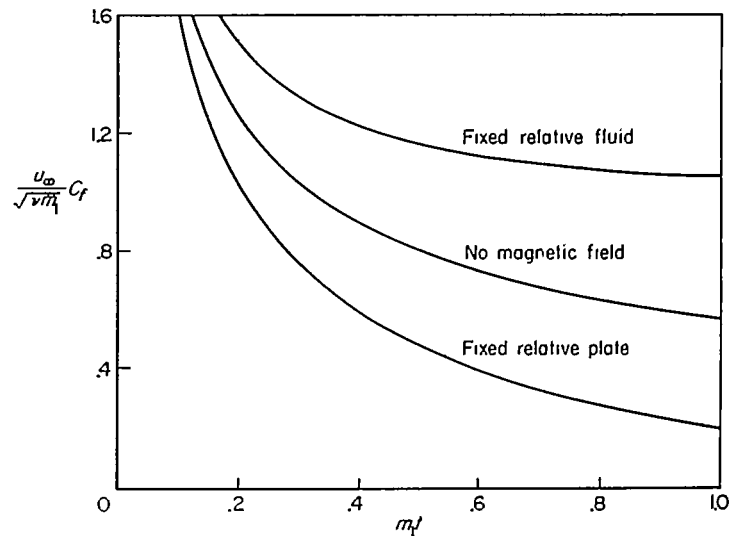

FIGURE 3.—Skin friction parameter as a function of a magnetic parameter.

The change in the velocity profile is a result of the force exerted by the magnetic field on the fluid. The reaction on the unit generating the magnetic field is expressed as

$$F/\text{unit area} = \int \sigma B_o^2 (u_\infty - u) dy = \sigma B_o^2 e^{-m_1 t} \int_0^{y \rightarrow \infty} \operatorname{erf} \frac{y}{2\sqrt{\nu t}} dy \tag{19b}$$

The force per unit area goes to infinity as the upper limit of integration goes to infinity because the magnetic field extends

undiminished an infinite distance from the plate. Thereby, an infinite amount of fluid is accelerated, resulting in an infinite force.

MAGNETIC FIELD FIXED RELATIVE TO THE FLUID

At all times less than zero the fluid, magnetic field, and plate are assumed to be at rest. At time $t=0$ the plate begins moving with velocity $u=u_\infty$ but the magnetic field remains at rest. The differential equation is the same as equation (12) because there is no relative motion between the fluid at $y=\infty$ and the magnetic field.

$$\frac{\partial u}{\partial t} + m_1 u = \nu \frac{\partial^2 u}{\partial y^2} \tag{20}$$

The boundary conditions are

$$\begin{aligned} u &= u_\infty & \text{at } y=0 \quad t \geq 0 \\ u &= 0 & \text{at } y > 0 \quad t=0 \end{aligned}$$

Applying the Laplace transformation to equation (20), as was done in the previous section, yields the transformed equation

$$\nu \frac{d^2 \bar{u}}{dy^2} = \bar{u}(s + m_1)$$

The solution to this ordinary differential equation is

$$\bar{u} = C_1(s) e^{-\nu \sqrt{\frac{s+m_1}{\nu}}} + C_2 e^{+\nu \sqrt{\frac{s+m_1}{\nu}}}$$

where the constant C_2 is set equal to zero because of the requirement of a finite velocity at $y=\infty$. The integration constant, $C_1(s)$, is found from the boundary condition at $y=0, t \geq 0$, as

$$C_1(s) = \frac{u_\infty}{s}$$

Equation (20) can be written as

$$\bar{u} = \frac{u_\infty}{(s+m_1) - m_1} e^{-\sqrt{s+m_1} \frac{y}{\nu}}$$

This equation can be inverted with the aid of reference 30 as

$$u = \frac{u_\infty}{2} \left[e^{-\nu \sqrt{\frac{m_1}{\nu}}} \operatorname{erfc} \left(\frac{y}{2\sqrt{\nu t}} - \sqrt{m_1 t} \right) + e^{+\nu \sqrt{\frac{m_1}{\nu}}} \operatorname{erfc} \left(\frac{y}{2\sqrt{\nu t}} + \sqrt{m_1 t} \right) \right] \tag{21}$$

The symbol *erfc* denotes the complementary error function defined as $1 - \operatorname{erf}$ (see, e. g., p. 370 of ref. 31). The velocity is once again dependent on more than one parameter so that a single similar profile cannot be drawn. Several profiles are shown in figure 2 (b). The fluid at $y=\infty$ is not disturbed in this case because the velocity across the magnetic lines is zero. In the vicinity of the plate the induced magnetic force counteracts the acceleration force of viscosity resulting in an increased rate of shear at the walls as expressed by the skin-friction coefficient.

$$c_f = \frac{2\nu}{u_\infty} \left(\sqrt{\frac{m_1}{\nu}} \operatorname{erf} \sqrt{m_1 t} + \frac{e^{-m_1 t}}{\sqrt{\pi \nu t}} \right) \tag{22}$$

Even at time, $t = \infty$, a friction force acts on the plate—a situation contrary to the previous case and the Rayleigh problem. Values computed by equation (22) are shown in figure 3.

The force on the magnetic field is given by

$$F/\text{unit area} = \int_0^\infty \sigma B_0^2 u \, dy \tag{23}$$

where u is given by equation (21). The force is finite in this case.

Another case which may be of interest arises when the magnetic field is fixed on the plate but a pressure gradient compensates for the action of the magnetic field at $y = \infty$. A flow of this character may be imagined to exist in the early stages of boundary-layer formation on the walls of a two-dimensional channel. The conducting fluid is assumed to be pumped through a channel containing a stationary transverse magnetic field. A pressure gradient arises automatically to compensate for the resistance of the magnetic field. The equations then describe the boundary layer as a function of time, after the pump has started. For this case equation (7) reduces to

$$\frac{\partial u}{\partial t} + m_1(u - u_\infty) + \frac{1}{\rho} \frac{\partial p}{\partial x} = \nu \frac{\partial^2 u}{\partial y^2}$$

The pressure gradient $\frac{1}{\rho} \frac{\partial p}{\partial x}$ is found by examining the boundary condition mentioned above at $y = \infty$. At $y = \infty$

$$\frac{\partial u}{\partial t} = \frac{\partial^2 u}{\partial y^2} = u = 0$$

Therefore, at $y = \infty$,

$$-m_1 u_\infty + \frac{1}{\rho} \frac{\partial p}{\partial x} = 0$$

and the above equation becomes equation (12). Since the boundary conditions are the same as when the magnetic field was fixed relative to the fluid, the results shown in figures 2 (b) and 3 apply here also.

BOUNDARY LAYER ON A SEMI-INFINITE FLAT PLATE

In the analysis of the boundary layer on a flat plate moving impulsively, it was found that the shape of the boundary-layer velocity profile changes with time, necessitating a new calculation at each instant. Therefore, a simple transformation of the coordinates would not yield a similar solution wherein all profiles could be drawn as one. It is then to be expected that in the flow of an incompressible fluid over a semi-infinite flat plate in the presence of a magnetic field, a similar solution will not exist. Since the boundary-layer solution of Blasius is not known in closed form and the velocity profiles at two different stations along the plate are not similar, a numerical solution to a series expansion is found by the method used in reference 33. The first or zero-order term is found to be the same as the Blasius solution which is well known and is tabulated, for example, on page 103 of reference 28. The first nonzero term will be calculated for the cases studied here.

The boundary-layer velocity and temperature profiles will be found for three cases. The conductivity of the fluid is assumed to be uniform throughout the flow field in the first

and second cases. A particular variation is assumed in the third case. The magnetic field is fixed relative to the plate in the first and third cases and relative to the fluid in the second case. A fourth case is shown to be equivalent to the second. In all cases the fluid will be assumed to be incompressible and to have a Prandtl number of 1.⁵

MAGNETIC FIELD FIXED RELATIVE TO THE PLATE

Velocity profile.—The magnetic field lines of force are assumed to be perpendicular to the free-stream direction and to begin at the leading edge of the plate as indicated in figure 4. An experimental setup may be imagined to consist of a wing or flat plate in a stream of conducting fluid such as mercury, sodium, or salt water. A magnetic field is impressed across the flow field using either a permanent or electro-magnet.

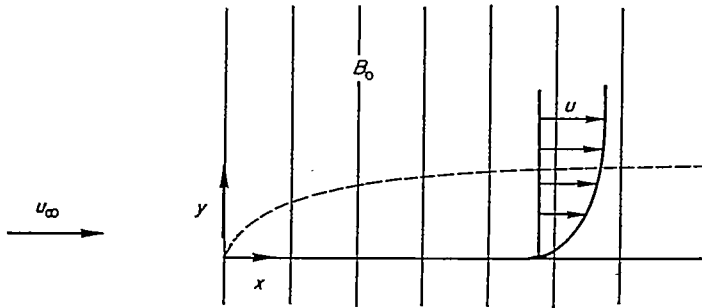

FIGURE 4.—Fluid flowing past a semi-infinite flat plate in the presence of a transverse magnetic field.

On the basis of the usual boundary-layer assumptions, equation (7) reduces to

$$u \frac{\partial u}{\partial x} + v \frac{\partial u}{\partial y} + m_1 u = \nu \frac{\partial^2 u}{\partial y^2} \quad (24)$$

The boundary conditions are that $u=0$ at $y=0$ and $u=u_\infty$ upstream of the plate. At $y=\infty$, $\partial u/\partial y=0$ and $\partial u/\partial x=-m_1$. Outside of the boundary layer the continuity equation requires that $\partial v/\partial y=m_1$; therefore, $v \rightarrow \infty$ as $y \rightarrow \infty$. If the flow field is restricted to the vicinity of the surface of the flat plate, no real difficulty arises. In an actual problem the magnetic field will not extend uniformly to large distances from the plate. At the location where the magnetic field strength dies out another viscous layer will develop. This slip layer will be ignored. Equation (24) is the same as the incompressible boundary-layer equation except for the additional term $m_1 u$. As was done in the Blasius boundary-layer solution, the transformation,

$$\left. \begin{aligned} \xi &= x \\ \eta &= y \sqrt{\frac{u_\infty}{\nu x}} \end{aligned} \right\} \quad (25)$$

is introduced. The stream function, ψ , is defined as

$$\psi = \sqrt{u_\infty \nu x} [f_0 + \sqrt{mx} f_1 + mx f_2 + (mx)^{3/2} f_3 + (mx)^2 f_4 \dots] \quad (26)$$

where the functions f_0, f_1, f_2, \dots are functions of η only. The series expansion in \sqrt{mx} is suggested by equation (21),

⁵Recent theoretical computations by Hansen (ref. 34) indicate that when the air is ionized up to 20 or 25 percent, a more realistic value for the Prandtl number would be about 0.3. When the gas becomes fully ionized, the Prandtl number drops off to the order of 0.01.

where the exact form of m is yet to be determined. If the expression (21) is expanded in a power series in mx , the odd power terms contributed by the first and second parts cancel each other. Also, if these terms are carried along in the following analysis, the corresponding functions are found to be zero. Therefore, only whole powers of mx will be considered in what follows.

The velocity components and their derivatives are found from equations (25) and (26) as

$$u = \frac{\partial \psi}{\partial y} = \frac{\partial \psi}{\partial \xi} \frac{\partial \xi}{\partial y} + \frac{\partial \psi}{\partial \eta} \frac{\partial \eta}{\partial y}$$

$$u = u_\infty [f_0' + mx f_2' + (mx)^2 f_4' \dots] \quad (27)$$

$$v = -\frac{\partial \psi}{\partial x} = -\frac{\partial \psi}{\partial \xi} \frac{\partial \xi}{\partial x} - \frac{\partial \psi}{\partial \eta} \frac{\partial \eta}{\partial x}$$

$$v = \frac{1}{2} \sqrt{\frac{u_\infty \nu}{x}} [f_0' + mx f_2' + (mx)^2 f_4' + \dots] -$$

$$\frac{1}{2} \sqrt{\frac{u_\infty \nu}{x}} [f_0 + 3mx f_2 + 5(mx)^2 f_4 + \dots] \quad (28)$$

Similarly,

$$\frac{\partial u}{\partial x} = -\frac{\eta}{2} \frac{u_\infty}{x} [f_0'' + mx f_2'' + (mx)^2 f_4'' + \dots] +$$

$$\frac{u_\infty}{2x} [2mx f_2' + 4(mx)^2 f_4' + \dots] \quad (29a)$$

$$\frac{\partial u}{\partial y} = u_\infty \sqrt{\frac{u_\infty}{\nu x}} [f_0'' + mx f_2'' + (mx)^2 f_4'' + \dots] \quad (29b)$$

$$\frac{\partial^2 u}{\partial y^2} = \frac{u_\infty^2}{\nu x} [f_0''' + mx f_2''' + (mx)^2 f_4''' + \dots] \quad (29c)$$

When equations (27) through (29) are substituted into equation (24) and the like powers of

$$mx = \frac{\sigma B_0^2}{\rho u_\infty} x = \frac{\overline{M}^2}{Re_x} \quad (30)$$

are equated, the following differential equations result:

$$2f_0''' = -f_0'' f_0 \quad (31)$$

$$f_2''' = f_0' f_2' - \frac{1}{2} f_0 f_2'' - \frac{3}{2} f_2 f_0'' + f_0' \quad (32a)$$

$$f_4''' = 2f_0' f_4' + f_2' f_2' - \frac{1}{2} f_0 f_4'' - \frac{3}{2} f_2 f_2'' - \frac{5}{2} f_4 f_0'' + f_2' \quad (32b)$$

etc.

The boundary conditions are

$$f_0 = f_2 = f_4 = \dots = 0 \text{ at } \eta = 0$$

$$f_0' = f_2' = f_4' = \dots = 0 \text{ at } \eta = 0$$

$$f_0' = 1 \text{ and } f_2' = -1 \text{ at } \eta = \infty$$

$$f_4' = f_6' = \dots = 0 \text{ at } \eta = \infty$$

The differential equations for f_2 and f_4 are linear ordinary differential equations with variable coefficients. Since the coefficients (Blasius solution) are not known in closed form, the equations must be integrated numerically. Only the functions f_2 and f_4 of the series will be found because the work involved is sizable and it is the intent of this study to find the over-all trends and gross effects rather than precise results.

The Runge-Kutta method was used to integrate both the homogeneous and nonhomogeneous forms of equations (32a) and (32b). The integration is started at the surface of the plate using two boundary conditions and then assuming a value for f_2'' and f_4'' . The correct solution is found by a proper combination of the numerical solutions to the homogeneous and nonhomogeneous equations. The factor by which the homogeneous equation is to be multiplied is found from the boundary condition at $\eta = \infty$. The numerical results for f_2 and f_4 are tabulated in table I (a). The velocity profiles shown in figure 5 (a) indicate that the flow separation at $mx=0.5$ will probably not be predicted if a sufficient number of terms are taken in the series (27). The first three terms (f_0' , f_2' , and f_4') describe the velocity in the boundary layer quite well up to at least $mx=0.2$.

The skin-friction coefficient and the displacement δ^* of an incoming streamline are

$$c_f = \frac{0.664 - 1.789 mx + 0.706 m^2 x^2 - \dots + \dots}{\sqrt{Re_x}} \quad (33a)$$

$$\delta^* = mx\eta + (1.73 + 0.54 mx + 1.34 m^2 x^2 + \dots) \sqrt{\frac{\nu x}{u_\infty}} \quad (33b)$$

The unit generating the magnetic field is assumed to be carried by the aircraft. The drag on this unit caused by the magnetic-field-fluid interaction is

$$F/\text{unit area} = \int_0^{\eta \rightarrow \infty} \sigma B_0^2 u \, dy$$

Substituting equation (27),

$$\begin{aligned} F/\text{unit area} &= \sigma B_0^2 \sqrt{u_\infty \nu x} \int_0^{\eta \rightarrow \infty} (f_0' + mx f_2' + \dots) d\eta \\ &= \sigma B_0^2 \sqrt{u_\infty \nu x} (f_0 + mx f_2 + \dots)_{\eta \rightarrow \infty} \end{aligned} \quad (33c)$$

The force is finite only for a conducting layer of finite thickness.

Temperature profile.—When the pressure gradients are reasoned to be everywhere zero and the usual two-dimensional boundary-layer assumptions are made, equation (11) reduces to

$$\rho u C_p \frac{\partial T}{\partial x} + \rho v C_p \frac{\partial T}{\partial y} - \sigma B_0^2 u^2 = \frac{C_p \mu}{Pr} \frac{\partial^2 T}{\partial y^2} + \mu \left(\frac{\partial u}{\partial y} \right)^2 \quad (34)$$

If total energy is defined as

$$E = C_p T + \frac{u^2}{2} \quad (35)$$

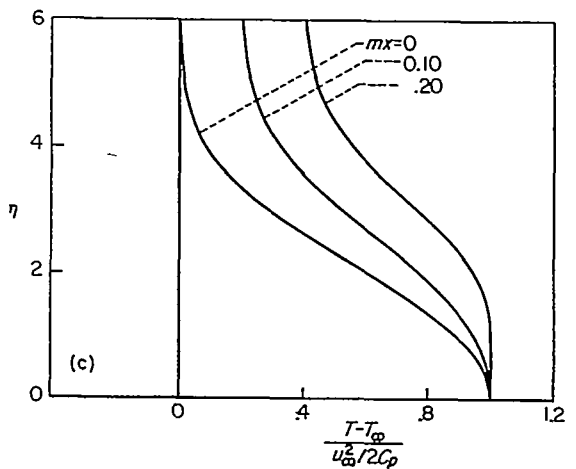
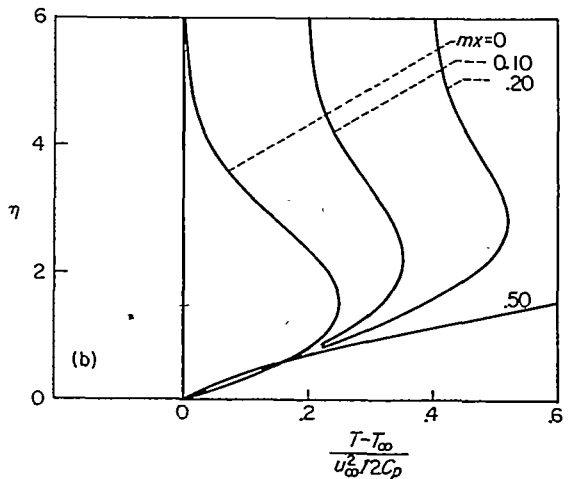
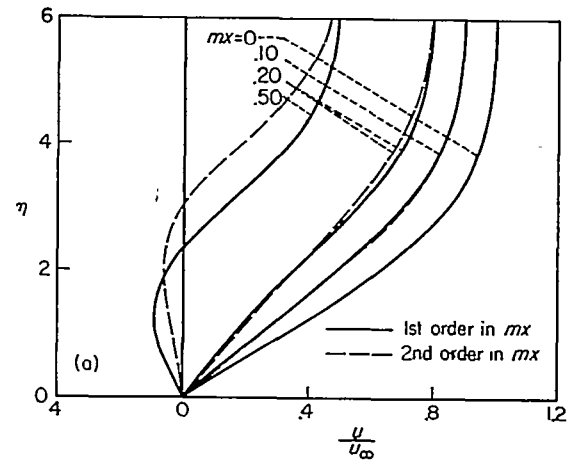

(a) Velocity.
(b) Temperature distribution for a cool wall, $T_w = T_\infty$.
(c) Temperature distribution for an insulated wall.

FIGURE 5.—Boundary-layer profiles for fluid flowing over a semi-infinite flat plate with a transverse magnetic field fixed relative to the plate.

equations (24) and (34) can be combined to yield a differential equation for the transport of total energy E ; that is, if equation (24) is multiplied by u , added to equation (34), and the Prandtl number, Pr , is assumed to be 1,

$$u \frac{\partial E}{\partial x} + v \frac{\partial E}{\partial y} = \nu \frac{\partial^2 E}{\partial y^2} \quad (36)$$

TABLE I.—MAGNETIC FIELD FIXED RELATIVE TO PLATE

(a) Stream function							(b) Temperature function for cold plate		(c) Temperature function for insulated plate	
η	f_s	f_s'	f_s''	f_t	f_t'	f_t''	$\frac{T_2}{u_\infty^2/2C_p}$	$\frac{T_1'}{u_\infty^2/2C_p}$	$\frac{T_2}{u_\infty^2/2C_p}$	$\frac{T_1'}{u_\infty^2/2C_p}$
0	0	0	-0.894	0	0	0.353	0	-0.352	0	0
.2	-.018	-.178	-.888	.007	-.069	.338	-.047	-.115	.024	.239
.4	-.071	-.354	-.868	.027	-.132	.287	-.046	-.116	.094	.465
.6	-.159	-.625	-.835	.059	-.183	.213	-.001	-.336	.209	.679
.8	-.281	-.887	-.789	.099	-.216	.117	.087	-.538	.394	.867
1.0	-.433	-.939	-.730	.144	-.228	.068	.213	-.715	.554	1.024
1.2	-.616	-.978	-.660	.189	-.218	-.111	.370	-.859	.771	1.139
1.4	-.824	-1.102	-.579	.230	-.184	-.228	.553	-.965	1.006	1.207
1.6	-1.055	-1.209	-.489	.261	-.127	-.338	.754	1.028	1.250	1.224
1.8	-1.306	-1.298	-.394	.279	-.050	-.431	.962	1.047	1.492	1.187
2.0	-1.573	-1.367	-.296	.280	-.044	-.500	1.169	1.020	1.722	1.102
2.2	-1.852	-1.416	-.197	.261	-.148	-.539	1.367	.854	1.930	.973
2.4	-2.138	-1.446	-.103	.221	-.267	-.544	1.549	.854	2.108	.811
2.6	-2.429	-1.458	-.017	.159	-.363	-.514	1.707	.730	2.253	.628
2.8	-2.720	-1.464	.059	.076	-.460	-.450	1.840	.593	2.369	.440
3.0	-3.010	-1.435	.121	-.024	-.541	-.358	1.944	.453	2.429	.259
3.2	-3.294	-1.408	.168	-.139	-.602	-.247	2.021	.321	2.464	.086
3.4	-3.572	-1.369	.201	-.264	-.640	-.125	2.074	.205	2.469	-.039
3.6	-3.841	-1.327	.218	-.393	-.653	-.005	2.105	.108	2.451	-.143
3.8	-4.102	-1.283	.222	-.523	-.642	.106	2.118	.033	2.414	-.213
4.0	-4.354	-1.239	.216	-.649	-.611	.199	2.119	-.020	2.367	-.253
4.2	-4.598	-1.197	.200	-.767	-.564	.269	2.112	-.054	2.315	-.267
4.4	-4.833	-1.159	.180	-.874	-.505	.314	2.099	-.072	2.262	-.260
4.6	-5.062	-1.125	.156	-.968	-.440	.335	2.083	-.078	2.212	-.239
4.8	-5.284	-1.097	.131	-1.049	-.373	.334	2.068	-.075	2.167	-.210
5.0	-5.501	-1.073	.107	-1.117	-.307	.316	2.054	-.068	2.128	-.177
5.2	-5.713	-1.054	.085	-1.173	-.247	.285	2.041	-.058	2.096	-.144
5.4	-5.923	-1.039	.065	-1.217	-.194	.248	2.030	-.047	2.070	-.113
5.6	-6.129	-1.028	.049	-1.251	-.148	.208	2.022	-.037	2.050	-.084
5.8	-6.334	-1.019	.036	-1.277	-.111	.168	2.016	-.028	2.035	-.057
6.0	-6.537	-1.013	.026	-1.296	-.081	.132	2.011	-.021	2.024	-.034
6.2	-6.739	-1.009	.018	-1.309	-.057	.101	2.007	-.015	2.016	-.023
6.4	-6.940	-1.006	.012	-1.319	-.040	.075	2.005	-.010	2.011	-.015
6.6	-7.141	-1.004	.008	-1.326	-.027	.054	2.003	-.007	2.007	-.010
6.8	-7.342	-1.002	.005	-1.330	-.018	.038	2.002	-.004	2.005	-.006
7.0	-7.542	-1.001	.003	-1.333	-.012	.028	2.001	.003	2.003	-.004
7.2	-7.743	-1.001	.002	-1.335	-.008	.017	2.001	.002	2.002	-.002
7.4	-7.943	-1.001	.001	-1.336	-.005	.011	2.000	.001	2.002	-.001
7.6	-8.143	-1.0	.001	-1.337	-.003	.007	2.000	.001	2.001	-.001
7.8	-8.343	-1.0	0	-1.337	-.002	.004	2.000	0	2.000	0
8.0	-8.543	-1.0	0	-1.338	-.001	.002	2.000	0	2.000	0
8.2	-8.743	-1.0	0	-1.338	0	.001	2.000	0	2.000	0
8.4	-8.943	-1.0	0	-1.338	0	0	2.000	0	2.000	0
8.6	-9.143	-1.0	0	-1.338	0	0	2.000	0	2.000	0

Although the temperature distribution is altered by the presence of the magnetic field because u and v are affected, the total energy of the conducting fluid is not. The kinetic energy removed by the force of the magnetic field is exactly equal to the heat generated by the electric current, independent of the field strength B_0 and the conductivity σ . An analogy may be drawn by considering a similar situation for an electric motor. Assume the motor to be rotating at a given speed. The power is then turned off and the armature is short-circuited. The motor will decelerate at a given rate depending on the field strength, resistance of the circuit, and rotational speed, just as in the fluid flow problem. The temperature rise of the wires, insulation, etc., however, depends only on the initial kinetic energy of the rotor. If the conductivity of the wires (or fluid) is reduced, the time required to stop the motion will be increased but the total j^2/σ or joule heat is not changed.

A first-order estimate of the influence of the magnetic field on the temperature profile can be found from equation (34) together with equations (25) through (29) and table I (a). Assume that

$$T = T_0(\eta) + T_2(\eta)m^2 + T_4(\eta)m^2x^2 + \dots \quad (37)$$

where, T_2, T_4, \dots are functions only of $\eta = y \sqrt{\frac{u_\infty}{\nu x}}$ and $T_1 = T_3 = T_5 \dots = 0$ as in the part of the problem dealing with the velocity profile. The derivatives of the tempera-

ture with respect to x and y are found as

$$\frac{\partial T}{\partial x} = \frac{\partial T}{\partial \xi} \frac{\partial \xi}{\partial x} + \frac{\partial T}{\partial \eta} \frac{\partial \eta}{\partial x}$$

$$\frac{\partial T}{\partial x} = \frac{1}{x} \left[mxT_2 + 2m^2x^2T_4 + \dots - \frac{\eta}{2} (T_0' + mxT_2' + m^2x^2T_4' + \dots) \right] \quad (38)$$

$$\frac{\partial T}{\partial y} = \frac{\partial T}{\partial \eta} \frac{\partial \eta}{\partial y} = \sqrt{\frac{u_\infty}{\nu x}} (T_0' + mxT_2' + m^2x^2T_4' + \dots)$$

When the various expressions are inserted into equation (34) and terms containing like powers of mx are equated, the differential equations for T_0 and T_2 are

$$\frac{T_0''}{Pr} + \frac{T_0'f_0}{2} + \frac{u_\infty^2(f_0'')^2}{C_p} = 0 \quad (39)$$

$$\frac{T_2''}{Pr} + \frac{T_2'f_0}{2} - f_0'T_2 + \frac{3}{2}f_2T_0' + \frac{u_\infty^2}{C_p} (f_0'^2 + 2f_0''f_2') = 0 \quad (40)$$

The boundary conditions are

$$\begin{aligned} T_0 &= T_w & \text{at } \eta = 0 \\ T_0 &= T_\infty & \text{at } \eta = \infty \\ T_2'' &= T_2' = 0 & \text{at } \eta = \infty \\ T_2 &= 0 & \text{at } \eta = 0 \end{aligned}$$

The solution to equation (39) was first found by Pohlhausen and is discussed on page 246 ff. of reference 28. The function $T_o(\eta)$ is the temperature profile for a boundary layer on a flat plate and is given by (assuming $Pr=1$)

$$T_o = T_\infty + \left(T_w - T_\infty - \frac{u_\infty^2}{2C_p} \right) (1 - f_o') + \frac{u_\infty^2}{2C_p} (1 - f_o'^2) \quad (41)$$

The derivative of T_o to be inserted into equation (40) becomes

$$T_o' = -f_o'' \left(T_w - T_\infty - \frac{u_\infty^2}{2C_p} + \frac{u_\infty^2}{C_p} f_o' \right) \quad (42)$$

For simplicity, the temperature of the plate will be assumed to be the same as that of the fluid far from the plate; that is, $T_w = T_\infty$. Equation (40) then becomes ($Pr=1$)

$$T_2'' + \frac{f_o}{2} T_2' - f_o' T_2 + \frac{u_\infty^2}{C_p} \left[\frac{3}{2} f_2 f_o'' \left(\frac{1}{2} - f_o' \right) + (f_o')^2 + 2f_o'' f_2'' \right] = 0 \quad (43)$$

Equation (43) was integrated numerically by the same method used for equation (32a) and the results are tabulated in table I (b). Several temperature profiles are shown in figure 5 (b). The quantity of heat transferred to the plate per unit time is

$$q = k \left. \frac{\partial T}{\partial y} \right|_{y=0} \quad (44a)$$

The local convective heat-transfer rate is ($Pr=1$)

$$h = \frac{q}{u_\infty^2 / 2C_p} = \frac{\rho u_\infty C_p}{2\sqrt{Re_x}} (0.664 - 0.704 mx - \dots + \dots) \quad (44b)$$

In the limit as the conductivity or field strength vanishes ($m \rightarrow 0$), equation (44b) reduces to

$$h)_{m=0} = \frac{f_o'' u_\infty \rho C_p}{\sqrt{Re_x}} \quad (45a)$$

or by virtue of equation (33a)

$$h)_{m=0} = \frac{1}{2} c_p \rho u_\infty C_p \quad (45b)$$

Equation (45b) is often identified as Reynolds analogy. A similar relation of equal simplicity was not found for the problems treated in this paper.

The differential equation for flow over an insulated plate is obtained from equation (40) by introducing the proper expression for T_o' . The solution of equation (39) for the insulated plate case is (see, e. g., ref. 28)

$$T_o = T_\infty + \frac{u_\infty^2}{2C_p} (1 - f_o'^2) \quad (46a)$$

and therefore,

$$T_o' = -\frac{u_\infty^2}{C_p} f_o' f_o'' \quad (46b)$$

Equation (40) then becomes, for the insulated plate case ($Pr=1$),

$$T_2'' + \frac{T_2' f_o}{2} - f_o' T_2 - \frac{u_\infty^2}{C_p} \left[\frac{3}{2} f_2 f_o' f_o'' - (f_o')^2 - 2f_o'' f_2'' \right] = 0 \quad (46c)$$

The temperature profiles (table I (c)) for several values of mx are shown in figure 5 (c). It is to be noted that the recovery temperature is not altered by the magnetic field. Such a result is to be expected since the magnetic field and the fluid at the wall do not interact.

MAGNETIC FIELD FIXED RELATIVE TO THE FLUID

Velocity profile.—In this case the magnetic lines of force move past the plate at the free-stream velocity. The fluid, which is decelerated by the viscous action of the plate, receives a push from the magnetic field which counteracts the viscous effect. Such a situation exists when a plate, vane, or wing moves through a stationary electrically conducting fluid and magnetic field. The boundary layer on a wing of an aircraft flying in the ionosphere over the magnetic poles of the earth could be considered to correspond to this case. Under these circumstances, equation (7) reduces to

$$u \frac{\partial u}{\partial x} + v \frac{\partial u}{\partial y} + \frac{\sigma B_o^2}{\rho} (u - u_\infty) = \nu \frac{\partial^2 u}{\partial y^2} \quad (47)$$

If the transformation of coordinates and the stream function described by equations (25) and (26) are introduced into equation (47), a set of ordinary linear differential equations with variable coefficients is found for f_2, f_4, \dots

$$f_2''' = f_o' f_2' - \frac{1}{2} f_o' f_2'' - \frac{3}{2} f_2 f_o'' + f_o' - 1 \quad (48a)$$

$$f_4''' = 2f_o' f_4' + f_2' f_2' - \frac{1}{2} f_o' f_4'' - \frac{3}{2} f_2 f_2'' - \frac{5}{2} f_4 f_o'' + f_2' \quad (48b)$$

The boundary conditions are

$$f_o = f_2 = f_4 = \dots = 0 \quad \text{at } \eta = 0$$

$$f_o' = f_2' = f_4' = \dots = 0 \quad \text{at } \eta = 0$$

$$f_o' = 1 \text{ and } f_2' = f_4' = \dots = 0 \quad \text{at } \eta = \infty$$

The integration for f_2 and f_4 was carried out by the same method described in the previous section and the results are tabulated in table II (a). Several velocity profiles are shown in figure 6 (a). The difference between the first- and second-order curves is small at small values of mx . However, the separation of the $mx=0.5$ curves indicates that the series expression (27) does not converge rapidly. More than two terms in the series must then be used if the velocity profile is to be predicted accurately at values of mx higher than about 0.2. The local skin-friction coefficient is

$$c_f = \frac{0.664 + 2.293 mx - 2.768 m^2 x^2 + \dots - \dots}{\sqrt{Re_x}} \quad (49a)$$

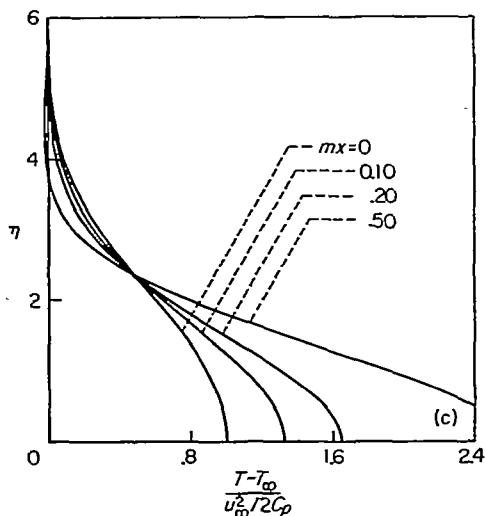
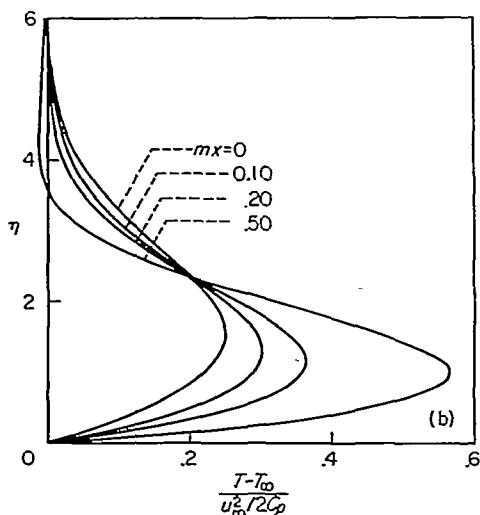
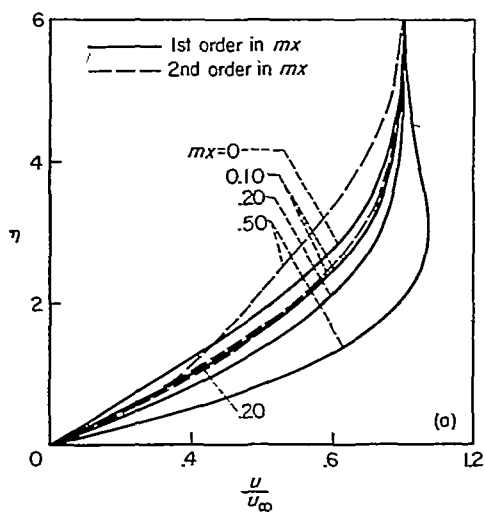

(a) Velocity.
 (b) Temperature distribution for a cool wall, $T_w = T_\infty$.
 (c) Temperature distribution for an insulated wall.

FIGURE 6.—Boundary-layer profiles for fluid flowing over a semi-infinite flat plate with a transverse magnetic field fixed relative to the fluid.

and the displacement thickness is

$$\delta^* = (1.73 - 2.21 mx + 5.22 m^2 x^2 - \dots + \dots) \sqrt{\frac{\nu x}{u_\infty}} \tag{49b}$$

The disturbance caused by viscous action on the plate results in a force on the magnetic field, which is given by

$$F/\text{unit area} = \int_0^{\eta \rightarrow \infty} \sigma B_o^2 (u_\infty - u) dy$$

From equations (27), (66), and table II (a),

$$\left. \begin{aligned} F/\text{unit area} &= \sigma B_o \sqrt{u_\infty \nu x} \int_0^{\eta \rightarrow \infty} (1 - f_o' - mx f_2' - \dots) d\eta \\ &= (1.73 - 2.21 mx + 5.22 m^2 x^2 - \dots + \dots) \sigma B_o^2 \sqrt{u_\infty \nu x} \\ &= \sigma u_\infty \delta^* B_o^2 \end{aligned} \right\} \tag{49c}$$

The force would appear as a reaction on the unit generating the magnetic field and not on the model which disturbs the fluid.

Equation (47) is identical with the differential equation for the case when the magnetic field is fixed with respect to the plate and a pressure gradient exists just strong enough to compensate for the electromagnetic effects at $\eta = \infty$. The boundary conditions and, hence, also the numerical results of table II (a) and figure 6 (a) can be applied to this problem.

Temperature profile.—Since the magnetic field lines are now moving relative to the plate, the expression for the electric current in the fluid is

$$j = \sigma B_o (u - u_\infty)$$

The equation for the transport of thermal energy in the boundary layer then becomes

$$\rho u C_p \frac{\partial T}{\partial x} + \rho v C_p \frac{\partial T}{\partial y} - \sigma B_o^2 (u - u_\infty)^2 = \frac{\mu C_p}{Pr} \frac{\partial^2 T}{\partial y^2} + \mu \left(\frac{\partial u}{\partial y} \right)^2 \tag{50}$$

If equations (47) and (50) are combined to describe the transport of total energy in the boundary layer ($Pr=1$)

$$\rho u \frac{\partial E}{\partial x} + \rho v \frac{\partial E}{\partial y} + u_\infty (u - u_\infty) \sigma B_o^2 = \mu \frac{\partial^2 E}{\partial y^2} \tag{51}$$

where, as before, $E = C_p T + \frac{u^2}{2}$. It is seen that the presence of

the magnetic field adds energy to the local element by doing work on the fluid retarded by viscosity. The magnitude of the work depends on the velocity, electrical conductivity, and field strength.

When the transformation of coordinates, equation (25), and the series expansion, equation (37), are inserted into equation (50), a set of differential equations is obtained for T_o, T_2, T_4, \dots . The relation for T_o is the same as equation (39) and that for T_2 is

$$\frac{T_2''}{Pr} + \frac{f_o}{2} T_2' - f_o' T_2 + \frac{3}{2} f_2 T_o' + \frac{u_\infty^2}{C_p} [(1 - f_o')^2 + 2 f_o'' f_2'] = 0 \tag{52a}$$

TABLE II.—MAGNETIC FIELD FIXED RELATIVE TO FLUID

(a) Stream function							(b) Temperature function for cold plate		(c) Temperature function for insulated plate	
η	f_2	f_2'	f_2''	f_1	f_1'	f_1''	$\frac{T_2}{u_\infty^2/2C_p}$	$\frac{T_2'}{u_\infty^2/2C_p}$	$\frac{T_2}{u_\infty^2/2C_p}$	$\frac{T_2'}{u_\infty^2/2C_p}$
0	0	0	1.147	0	0	-1.384	0	2.022	3.228	0
.2	.022	.210	.953	-.028	-.275	-1.362	.337	1.370	3.163	-.631
.4	.081	.382	.773	-.110	-.642	-1.300	.555	.821	2.985	-1.121
.6	.172	.520	.608	-.243	-.793	-1.205	.672	.370	2.723	-1.477
.8	.287	.626	.453	-.425	-1.022	-1.060	.709	.014	2.403	-1.710
1.0	.420	.702	.312	-.650	-1.224	-.932	.684	-.233	2.047	-1.830
1.2	.566	.752	.186	-.913	-1.394	-.785	.613	-.438	1.677	-1.851
1.4	.719	.777	.072	-1.205	-1.529	-.584	.513	-.549	1.312	-1.786
1.6	.876	.781	-.028	-1.522	-1.626	-.394	.398	-.596	.967	-1.652
1.8	1.031	.767	-.113	-1.854	-1.686	-.202	.279	-.589	.654	-1.466
2.0	1.181	.737	-.184	-2.193	-1.708	-.014	.165	-.541	.383	-1.245
2.2	1.325	.694	-.241	-2.534	-1.692	.165	.064	-.464	.158	-1.005
2.4	1.458	.642	-.282	-2.868	-1.643	.327	-.019	-.369	-.019	-.766
2.6	1.581	.582	-.310	-3.189	-1.563	.467	-.083	-.299	-.149	-.539
2.8	1.691	.519	-.323	-3.492	-1.458	.580	-.127	-.172	-.237	-.337
3.0	1.788	.454	-.324	-3.771	-1.333	.665	-.153	-.087	-.286	-.166
3.2	1.873	.390	-.314	-4.024	-1.195	.713	-.163	-.016	-.305	-.030
3.4	1.944	.329	-.296	-4.248	-1.050	.732	-.161	.036	-.301	.089
3.6	2.004	.272	-.270	-4.444	-.904	.722	-.149	.072	-.280	.134
3.8	2.054	.221	-.240	-4.610	-.763	.687	-.133	.092	-.249	.171
4.0	2.093	.176	-.208	-4.749	-.630	.632	-.114	.099	-.213	.184
4.2	2.124	.138	-.176	-4.863	-.511	.565	-.094	.097	-.177	.180
4.4	2.149	.105	-.145	-4.954	-.405	.490	-.075	.089	-.142	.168
4.6	2.167	.079	-.117	-5.026	-.315	.413	-.058	.077	-.111	.144
4.8	2.181	.058	-.092	-5.081	-.240	.339	-.044	.064	-.084	.120
5.0	2.191	.042	-.071	-5.123	-.179	.271	-.033	.051	-.063	.097
5.2	2.198	.030	-.053	-5.154	-.130	.212	-.024	.040	-.045	.076
5.4	2.203	.021	-.039	-5.176	-.093	.161	-.017	.030	-.032	.057
5.6	2.206	.014	-.028	-5.192	-.065	.120	-.012	.022	-.022	.042
5.8	2.209	.009	-.020	-5.203	-.045	.087	-.008	.016	-.015	.030
6.0	2.210	.006	-.013	-5.210	-.030	.061	-.005	.011	-.010	.021
6.2	2.211	.004	-.009	-5.215	-.020	.043	-.003	.007	-.006	.014
6.4	2.212	.002	-.006	-5.218	-.013	.029	-.002	.005	-.004	.010
6.6	2.212	.001	-.004	-5.220	-.008	.019	-.002	.003	-.003	.006
6.8	2.212	.001	-.002	-5.222	-.005	.013	-.001	.002	-.002	.004
7.0	2.213	0	-.002	-5.222	-.003	.008	0	.001	-.001	.002
7.2	2.213	0	-.001	-5.223	-.002	.005	0	.001	-.001	.002
7.4	2.213	0	0	-5.223	-.001	.003	0	0	0	.001
7.6	2.213	0	0	-5.223	-.001	.002	0	0	0	.001
7.8	2.213	0	0	-5.223	0	.001	0	0	0	0
8.0	2.213	0	0	-5.223	0	.001	0	0	0	0
8.2	2.213	0	0	-5.224	0	0	0	0	0	0
8.4	2.213	0	0	-5.224	0	0	0	0	0	0
8.6	2.213	0	0	-5.224	0	0	0	0	0	0

When the expression (42) is inserted into equation (52a) and it is assumed that $T_w = T_\infty$ and $Pr = 1$, the result is

$$T_2'' + \frac{f_2}{2} T_2' - f_2' T_2 + \frac{u_\infty^2}{C_p} \left[\frac{3}{2} f_2 f_2'' \left(\frac{1}{2} - f_2' \right) + (1 - f_2')^2 + 2f_2'' f_2'' \right] = 0 \tag{52b}$$

The boundary conditions are

$$T_2 = 0 \text{ at } \eta = 0$$

$$T_2 = 0 \text{ at } \eta = \infty$$

The numerical integration of equation (52b) was carried out by the method used earlier and the results are tabulated in table II (b). The temperature profiles shown in figure 6 (b) correspond to the same values of mx shown for the velocity profiles in figure 6 (a). The temperature gradient and the heat transfer to the wall are, respectively,

$$\frac{\partial T}{\partial y} \Big|_{y=0} = \frac{u_\infty^2}{2C_p} \sqrt{\frac{u_\infty}{\nu x}} (0.332 + 2.022 mx + \dots)$$

$$h = \frac{q}{u_\infty^2/2C_p} = \frac{\rho u_\infty C_p}{2\sqrt{Re_x}} (0.664 + 4.044 mx + \dots) \tag{53}$$

The recovery temperature for an insulated plate is altered by the relative motion between the magnetic field and the fluid at the plate. The differential equation for the pertur-

bation profiles are obtained by inserting equation (46b) into equation (52a).

$$T_2'' + \frac{f_2}{2} T_2' - f_2' T_2 - \frac{3u_\infty^2}{2C_p} f_2 f_2' f_2'' + \frac{u_\infty^2}{C_p} [(1 - f_2')^2 + 2f_2'' f_2''] = 0 \tag{54a}$$

Several typical temperature profiles (table II (c)) are shown in figure 6 (c). The recovery temperature at the wall is changed due to the j^2/σ or joule heating caused by the relative motion between the magnetic field and the fluid at the plate; that is, the recovery temperature at the wall is given by

$$T_r)_{y=0} = T_o + 1.614 \frac{u_\infty^2}{C_p} mx + \dots - \dots$$

$$T_r)_{y=0} = T_\infty + \frac{u_\infty^2}{2C_p} (1 + 3.228 mx + \dots - \dots) \tag{54b}$$

The heat transferred to the plate may also be written as $q = h(T_r - T_w)$, where T_r is the recovery temperature given by equation (54b) and T_w is the wall temperature. Since the magnetic field increases T_r , as well as τ , the heat-transfer rate is increased in two ways.

MAGNETIC FIELD FIXED RELATIVE TO PLATE-FLUID OF VARIABLE CONDUCTIVITY

Velocity profile.—Numerous problems in fluid dynamics exist wherein the electrical conductivity of the fluid or the strength of the magnetic field changes with distance from

the surface. The magnetic field strength can be varied somewhat by the design of the apparatus. It is possible to adjust not only the strength of the field but also the variation with distance from or along the surface within certain physical limits. A first approximation to the shape and magnitude of most magnetic fields would be a uniform magnetic field of constant magnitude throughout the flow field. Such a magnetic system will once again be chosen for this case.

The electrical conductivity of the fluid would be expected to vary in a complicated manner in directions along and perpendicular to the surface and from one situation to the next. The constant value chosen for the conductivity in the two previous cases is not realistic. The conductivity will vary under actual conditions of flow in a boundary layer. This will surely change the skin friction and heat transfer from that found in the last two cases. A logical variation will be studied in this section to see how large an effect a variable conductivity will have on c_f and h .

It is to be expected that the conductivity will vanish at the outer edge of the boundary layer and reach a maximum somewhere near the surface. The equations which can be used to determine the number of ions (and hence conductivity) in a stream at high temperature or under circumstances wherein combustion is taking place, are cumbersome. Therefore, a simple, approximate, analytical relation for the electrical conductivity as a function of temperature between the plate and outer edge of the boundary layer was not found. The conductivity of air after the passage of a normal shock wave has been measured in a shock tube and reported on page 339 of reference 3. The conductivity is reproduced in figure 7. At Mach numbers above 20, the results are approximated by a straight line.

In view of the lack of knowledge of the variation of σ in the boundary layer, a linear relation between the velocity

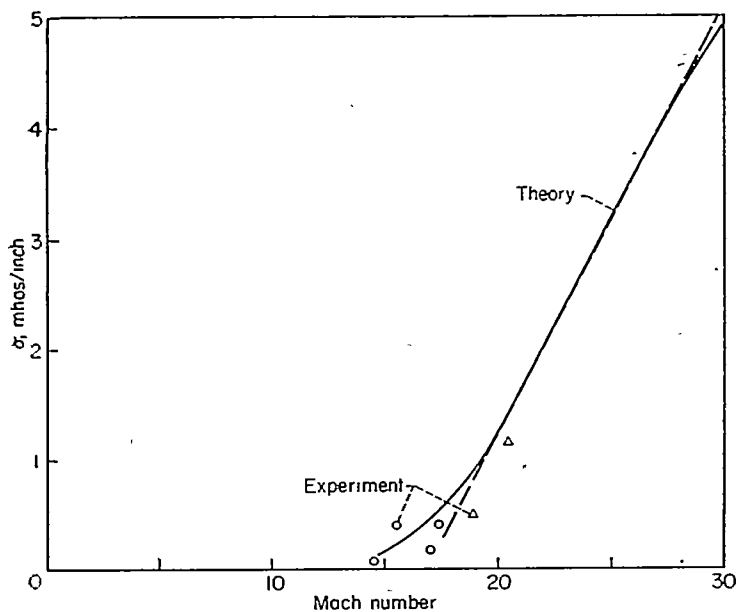

FIGURE 7.—Electrical conductivity of air as a function of shock wave Mach number as found in reference 3.

decrement and the conductivity will be chosen for this case. Therefore, it will be assumed that

$$\sigma = \sigma_o \left(\frac{u_\infty - u}{u_\infty} \right) \quad (55)$$

where σ_o is the conductivity at the surface, where $u=0$. Whether equation (55) is realistic is uncertain. Inserting the expression (55) into equation (24) gives

$$u \frac{\partial u}{\partial x} + \nu \frac{\partial u}{\partial y} + \frac{m_1 u}{u_\infty} (u_\infty - u) = \nu \frac{\partial^2 u}{\partial y^2} \quad (56)$$

As before, an ordinary differential equation for each of the functions f_2, f_4, \dots results when the variables in equations (25) and (26) are inserted into equation (56) and like powers of mx are equated.

$$f_2''' = f_o' f_2' - \frac{3}{2} f_2 f_o'' - \frac{1}{2} f_o f_2'' + f_o' (1 - f_o') \quad (57a)$$

$$f_4''' = 2f_o' f_4' + f_2' f_2' - \frac{1}{2} f_o f_4'' - \frac{3}{2} f_2 f_2'' - \frac{5}{2} f_4 f_o'' + f_2' - 2f_2' f_o' \quad (57b)$$

The boundary conditions are,

$$f_o = f_2 = f_4 = \dots = 0 \quad \text{when } \eta = 0$$

$$f_o' = f_2' = f_4' = \dots = 0 \quad \text{when } \eta = 0$$

$$f_o' = 1, f_2' = f_4' = \dots = 0 \quad \text{when } \eta = \infty$$

The numerical integration of equation (57a) was carried out for f_2 by the method used in the other cases and the results are tabulated in table III(a). Typical boundary-layer velocity profiles are shown in figure 8(a). The local skin-friction coefficient is

$$c_f = \frac{0.664 - 0.627 mx \pm \dots}{\sqrt{Re_x}} \quad (58a)$$

and the displacement thickness is

$$\delta^* = (1.73 + 0.97 mx + \dots) \sqrt{\frac{\nu x}{u_\infty}} \quad (58b)$$

The force on the unit generating the magnetic field is expressed by

$$F = \sigma B_o^2 \sqrt{u_\infty \nu x} \int_0^{\eta \rightarrow \infty} (1 - f_o' - mx f_2' - \dots) (f_o' + mx f_2' + \dots) d\eta / \text{unit area}$$

The integral is evaluated through the use of equation (57a) and table III (a) as

$$F = \sigma B_o^2 \sqrt{u_\infty \nu x} (0.664 + 0.649 mx + \dots) \text{lb/unit area} \quad (59a)$$

or, integrating from the leading edge to x ,

$$F = \frac{2}{3} x \sigma_o B_o^2 \sqrt{u_\infty \nu x} (0.664 + 0.390 mx + \dots) \text{lb/unit width} \quad (59b)$$

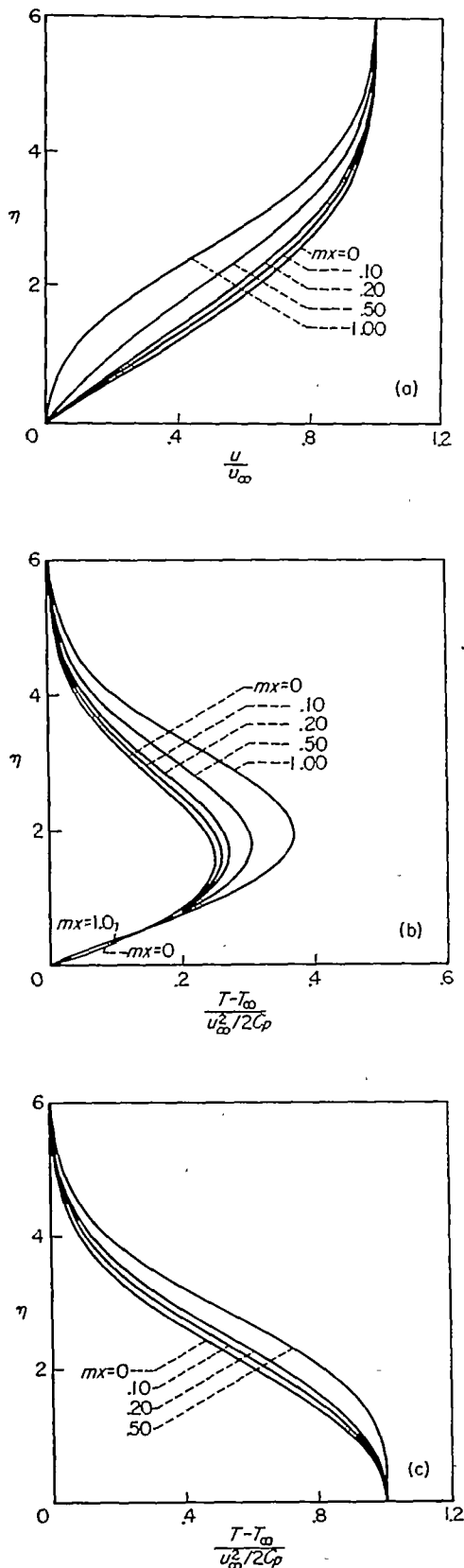

(a) Velocity.
 (b) Temperature distribution for a cool wall, $T_w = T_\infty$.
 (c) Temperature distribution for an insulated wall.

FIGURE 8.—Boundary-layer profiles for fluid flowing over a semi-infinite flat plate with a transverse magnetic field fixed relative to the plate-fluid of variable conductivity.

Equation (59a) or (59b) expresses a drag force on the plate which is to be added to the friction drag. In coefficient form, the local drag per unit area on the plate due to the magnetic field is

$$c_B = \frac{mx}{\sqrt{Re_x}} (1.328 + 1.299 mx + \dots) \quad (60a)$$

When equations (58a) and (60a) are added, the net local force coefficient to a first order in mx is

$$c_D = \frac{1}{\sqrt{Re_x}} (0.664 + 0.701 mx + \dots) \quad (60b)$$

The interference of the magnetic field reduces the skin friction at the expense of a higher drag.

Temperature profile.—The thermal-energy transport equation is reduced in the manner used in the previous cases. The electrical or joule heating is now described by

$$\frac{j^2}{\sigma} = \sigma_o B_o^2 \left(\frac{u_\infty - u}{u_\infty} \right) u^2$$

Equation (11) is then

$$\rho C_p u \frac{\partial T}{\partial x} + \rho v C_p \frac{\partial T}{\partial y} - \frac{\sigma_o B_o^2}{u_\infty} (u_\infty - u) u^2 = \frac{\mu C_p}{Pr} \frac{\partial^2 T}{\partial y^2} + \mu \left(\frac{\partial u}{\partial y} \right)^2 \quad (61)$$

If equation (56) is multiplied by u and added to equation (61), the resulting equation for the transport of total energy is identical with equation (36). Once again, the temperature distribution is changed but the total energy of the fluid is not altered by the presence of a magnetic field.

The change of variables ξ, η , the stream function, ψ , and temperature expansion given by equations (25), (26), and (37), respectively, are now introduced into equation (61). A set of linear ordinary differential equations for T_o, T_2, T_4, \dots is obtained for this case when like powers of mx are equated. The expression for T_o is once again the same as equation (39). The differential equation for T_2 is

$$\frac{T_2''}{Pr} + \frac{f_o T_2'}{2} - f_o' T_2 + \frac{3}{2} f_2 T_o' + \frac{u_\infty^2}{C_p} [(1 - f_o') f_o'^2 + 2 f_o'' f_2''] = 0 \quad (62)$$

If it is assumed that $Pr=1$ and the expression for T_o' is inserted into equation (62), the result is

$$T_2'' + \frac{f_o T_2'}{2} - f_o' T_2 + \frac{u_\infty^2}{C_p} \left[\frac{3}{2} f_2 f_o'' \left(\frac{1}{2} - f_o' \right) + (1 - f_o') f_o'^2 + 2 f_o'' f_2'' \right] = 0 \quad (63)$$

Numerical integration of equation (63) was carried out by the method used for the previous cases. The results are presented in table III (b) and several temperature profiles are shown in figure 8 (b). The coefficient for the convective heat-transfer rate is given by

$$h = \frac{\rho u_\infty C_p}{2\sqrt{Re_x}} (0.664 - 0.206 mx - \dots + \dots) \quad (64)$$

TABLE III.—MAGNETIC FIELD FIXED RELATIVE TO PLATE—VARIABLE CONDUCTIVITY

(a) First-order stream function				(b) Temperature function for cold plate		(c) Temperature function for insulated plate	
η	f_1	f_1'	f_1''	$\frac{T_1}{u_\infty^2/2C_p}$	$\frac{T_1'}{u_\infty^2/2C_p}$	$\frac{T_2}{u_\infty^2/2C_p}$	$\frac{T_2'}{u_\infty^2/2C_p}$
0	0	0	-0.313	0	-0.103	0	0
.2	-.006	-.062	-.307	-.012	-.021	.008	.082
.4	-.025	-.122	-.289	-.009	.056	.032	.158
.6	-.055	-.177	-.262	-.009	.122	.071	.221
.8	-.095	-.226	-.226	.039	.173	.120	.268
1.0	-.145	-.267	-.185	.077	.207	.176	.295
1.2	-.202	-.300	-.139	.121	.223	.236	.300
1.4	-.264	-.323	-.092	.165	.220	.295	.283
1.6	-.330	-.337	-.045	.208	.199	.348	.246
1.8	-.398	-.341	0	.244	.163	.392	.193
2.0	-.466	-.337	.004	.272	.117	.424	.128
2.2	-.532	-.325	.077	.290	.064	.443	.056
2.4	-.596	-.307	.106	.298	.010	.447	-.016
2.6	-.655	-.283	.128	.294	-.041	.437	-.081
2.8	-.709	-.256	.143	.282	-.085	.415	-.138
3.0	-.757	-.226	.150	.261	-.118	.383	-.180
3.2	-.799	-.196	.149	.235	-.140	.344	-.208
3.4	-.835	-.167	.144	.206	-.151	.301	-.221
3.6	-.868	-.139	.134	.175	-.152	.258	-.221
3.8	-.891	-.113	.121	.146	-.145	.213	-.210
4.0	-.911	-.090	.106	.118	-.132	.173	-.191
4.2	-.927	-.071	.090	.093	-.115	.137	-.167
4.4	-.940	-.054	.075	.072	-.097	.106	-.141
4.6	-.949	-.041	.060	.054	-.079	.080	-.116
4.8	-.956	-.030	.047	.040	-.063	.060	-.092
5.0	-.961	-.022	.036	.029	-.048	.043	-.072
5.2	-.965	-.015	.027	.020	-.036	.031	-.054
5.4	-.968	-.011	.020	.014	-.027	.021	-.040
5.6	-.970	-.007	.014	.009	-.019	.015	-.029
5.8	-.971	-.005	.010	.006	-.013	.010	-.020
6.0	-.972	-.003	.007	.004	-.009	.006	-.014
6.2	-.972	-.002	.005	.003	-.006	.004	-.009
6.4	-.972	-.001	.003	.002	-.004	.003	-.006
6.6	-.973	0	.002	.001	-.003	.002	-.004
6.8	-.973	0	.001	.001	-.002	.001	-.002
7.0	-.973	0	.001	0	-.001	.001	-.001
7.2	-.973	0	0	0	0	0	0
7.4	-.973	0	0	0	0	0	0
7.6	-.973	0	0	0	0	0	0
7.8	-.973	0	0	0	0	0	0
8.0	-.973	0	0	0	0	0	0
8.2	-.973	0	0	0	0	0	0
8.4	-.973	0	0	0	0	0	0
8.6	-.973	0	0	0	0	0	0

The influence of the magnetic field on the heat-transfer rate and skin friction is not so large in this case as in either of the two previous cases (eqs. (33a), (44b), (49a), and (53)). From these results it is apparent that the change in the heat-transfer rate and the skin friction is strongly dependent on the manner in which the conductivity (or magnetic field strength) vary through the boundary layer. A magnetic field which changes in strength with distance from the surface and a variable conductivity are to be expected in the real physical situation.

The differential equation for flow over an insulated plate is obtained by substitution of equation (46b) into equation (62).

$$T_2'' + \frac{f_0 T_2'}{2} - f_0' T_2 - \frac{3u_\infty^2}{2C_p} f_2 f_0' f_0'' + \frac{u_\infty^2}{C_p} [(1-f_0')f_0'^2 + 2f_0''f_2'] = 0$$

The temperature profiles for several values of $m\alpha$ are shown in figure 8 (c) and tabulated in table III (c). As would be expected, the recovery temperature at the wall is not altered by the magnetic field because there is no relative motion between the fluid at the wall and the magnetic field.

MAGNETIC PARAMETER

UNITS

The importance of the magneto-hydrodynamic effect depends on the size of the magnetic parameter $m = \sigma B_0^2 / \rho u_\infty$. The usual engineering units are: σ in mhos/inch; B_0 in lines/square inch; ρ in slugs/cubic foot; and u_∞ in feet/second. If each of these quantities is expressed as such, the parameter

$m\alpha$ will be dimensionless only if multiplied by a factor which relates the various dimensional quantities. When the correct conversion factors are inserted, reference 27,

$$m = 1.529 \times 10^{-12} \frac{\sigma \left(\frac{\text{mhos}}{\text{in.}} \right) \left[B_0 \left(\frac{\text{lines}}{\text{in.}^2} \right) \right]^2}{\rho \left(\frac{\text{slugs}}{\text{ft}^3} \right) u_\infty \left(\frac{\text{ft}}{\text{sec}} \right)} \text{ per inch} \quad (65a)$$

OR

$$m = 6.432 \times 10^{-10} \frac{\sigma \left(\frac{\text{mhos}}{\text{in.}} \right) \left[B_0 \left(\frac{\text{lines}}{\text{in.}^2} \right) \right]^2}{\left(\frac{\rho}{\rho_0} \right) u_\infty \left(\frac{\text{ft}}{\text{sec}} \right)} \text{ per inch} \quad (65b)$$

where $\rho_0 = 0.002378$ slugs/ft³ is the air density at sea level.

Another method of finding the conversion factor for m is to combine the electric motor equations (ref. 35)

$$F = 8.8507 \times 10^{-8} B_0 l i \text{ lb} \quad (66a)$$

$$E = B_0 l u \times 10^{-8} \text{ volts} = \frac{i}{\sigma l} \quad (66b)$$

so that

$$\frac{\text{Force}}{ul^3} = 8.8507 \times 10^{-16} \sigma B_0^2 \frac{\text{lb sec}}{\text{in.}^4}$$

OR

$$m = \frac{\text{force}/l^3}{\rho_0 (\rho/\rho_0) u^2} = \frac{(8.8507)(1728) 10^{-16} \sigma B_0^2}{0.002378} \frac{\sigma B_0^2}{(\rho/\rho_0) u} \text{ per inch}$$

$$= 6.432 \times 10^{-10} \frac{\sigma B_0^2}{(\rho/\rho_0) u} \text{ per inch}$$

In words, the parameter m expresses the ratio of electromagnetic force density to dynamic pressure.

The value of m can easily vary over many orders of magnitude. However, the density ρ and velocity u associated with a particular vehicle are generally fixed within relatively narrow limits. It remains, then, to adjust the conductivity and magnetic field strength so that the desired characteristics are achieved. The limits for the magnetic field strength lie between zero and a maximum (discounting astrophysical possibilities) of about 10^6 lines/sq in. The electrical conductivity depends on the fluid considered and can vary over wide limits from very small values for insulators to approximately 10^6 mhos/inch for metals. The results of several investigations of the conductivity of gases will be discussed in the next section.

ELECTRICAL CONDUCTIVITY

The information on the electrical conductivity⁶ of gases under the special conditions of this report is not large. However, it is known that the air around a missile will be a conductor if: (1) the energy imparted to the air is great enough to ionize it; (2) metal is ablated from the missile; (3) the missile is in the ionosphere where the air is ionized by radiation from the sun; or (4) other special devices are used to ionize the air, such as irradiation by high energy particles.

The electrical conductivity of air behind a normal shock wave has been measured in a shock tube and is reported on page 339 of reference 3. The results, replotted in figure 7, indicate conductivities of the order of 1 to 5 mhos/inch for air behind strong shock waves.

Firings of ultraspeed pellets, references 36 through 39, indicate that another phenomenon will enter the problem of conductivity. Photographs and spectrographs taken with special cameras show that metal is eroded or ablated from the pellet and swept off the model into the wake where it burns. Since the metal is in a liquid spray or vapor form while it is in the vicinity of the pellet, the conductivity there would be increased by a sizable amount. It would be difficult to estimate the orders of magnitude to be expected. The tests show that the air can be made a conductor by ionization of its molecules and atoms and/or by metal vapor or spray eroded from the surface of the vehicle. It is pointed out in reference 40 that the latter effect predominates when meteors enter the earth's atmosphere.

The air in the ionosphere is partially ionized by radiation from the sun so that it is a conductor without addition of energy from the aircraft. The amount of ionization at various altitudes and the total number of particles are listed in tables 2 and 9 of reference 41. A rough estimate of the conductivity is found from reference 7 as

$$\sigma = \frac{ne^2 l_e}{m_e U_e} \approx 3 \times 10^{-16} n \frac{N_0}{N} \text{ mhos/inch} \quad (67)$$

⁶ Good electrical conductors are always good heat conductors. The ratio may be expressed approximately as (ref. 7),

$$\frac{k}{\sigma T} = \frac{\pi^2}{3} \left(\frac{\kappa}{e} \right)^2$$

where k is the coefficient of thermal conductivity, κ is Boltzmann's constant, and e is the charge on an electron

where e , l_e , m_e , and U_e are the charge, mean free path length, mass, and velocity, respectively, of the electron and N_0 and N are the particle density at sea level and the altitude in question. The factor n is the electron density. The values for σ range from 10^{-4} mhos/in. at 62 miles altitude to about 32 mhos/in. at 250 miles altitude.

The large variety in fuels makes it difficult to bracket the magnitude of the conductivity of combustion products but information is available for several cases. It was reported in reference 5 that the conductivity of the jet from a 50-pound thrust acid-aniline rocket motor was measured as being about 10^{-8} mhos/in. It was added, however, that the addition of a small amount of an impurity such as sodium would strikingly increase the electron density.

A discussion is given in reference 6 of similar experiments and theory on the combustion of hydrocarbon fuels. The experimental evidence required that the number of electrons in the combustion products (10^{11} to 10^{14} per cc) be several orders of magnitude greater than predicted theoretically (10^8 to 10^9 per cc). The maximum conductivity can be estimated by equation (67) to be roughly 10^{-2} mhos/inch.

Although the conductivities discussed are low compared with those of metals, they appear to be large enough so that appreciable magneto-hydrodynamic forces can be exerted. If the conductivity is too low for a specific case, it may be possible that alkaline salts or some other additive can be used to increase the number of free electrons and ions.

APPLICATIONS

The possibility of using a magnetic field to prevent a hot fluid from coming in contact with a wall which it would dissolve or destroy was discussed in the introduction. The extent to which this can be accomplished is measured directly by the parameter $m = (\sigma B_0^2 / \rho u_\infty)$. The larger the parameter m is, the more effectively the "fluid suspension" process can be carried out. The influence of the magnetic field on the fluid is expressed in equations (33), (44), (49), (53), (58), . . . by the product $m\alpha$. The distance α represents an "adjustment distance" required before the fluid responds a given amount or adjusts to the magnetic lines of force. If the magnetic parameter is very large, the adjustment distance will be very small and the fluid will follow the magnetic lines of force quite closely as indicated in figure 9. The magnetic force restrains any motion across the lines of force because the inertia forces are insignificant in comparison. In this limit the magnetic lines of force are the same as invisible solid boundaries.

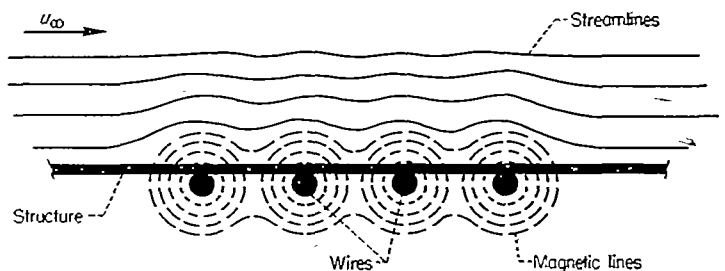

FIGURE 9.—Sketch of fluid of high electrical conductivity flowing over a surface.

If the parameter m is very small the adjustment distance x becomes very large and the influence of the magnetic field becomes negligible.

The numbers quoted in the last section for the conductivity and field strength indicate that most of the applications will lie between the two extreme limits.

FLOW OVER A HIGH-SPEED VEHICLE

Magneto-aerodynamic effects may be used to alter the external flow over aircraft. Examples which illustrate the changes in the boundary layer will now be discussed. It will be pointed out that the skin friction on an aircraft might be reduced by judicious use of a magnetic field either to inhibit transition to turbulent flow or to alter the boundary-layer profile.

It has been shown in reference 13 that the Reynolds number of transition is raised when a coplanar magnetic field is applied. The results of reference 13 can be used as a rough estimate for flows of the boundary-layer type when the particular velocity distribution may be approximated by a parabolic profile. This is permissible since a coplanar magnetic field does not change the velocity profile, which is not so for the cases considered in this paper.

The results of reference 14 for a transverse magnetic field apply to a two-dimensional channel and should not be used for flows of the boundary-layer type because of the change induced by the magnetic field on the velocity profile. For the flow in the two-dimensional channel the change in the velocity profile was largely responsible for the resistance to turbulence. The same will not always be true for other types of flow fields. It will then in general be necessary to carry out a stability calculation in order to determine whether a transverse magnetic field tends to stabilize or destabilize the boundary layer. A situation wherein the magnetic field destabilizes the flow field is presented in reference 26, warning one that the presence of a magnetic field does not always decrease the likelihood of transition.

The numerical results of table I and the equations (33) and (44) may be used to estimate the effects of a magnetic field attached to an aircraft on boundary layers of uniform electrical conductivity. The model analyzed theoretically will probably never be duplicated in a physical situation. However, circumstances may arise wherein the conductivity and magnetic field are such that they vary only slightly or are almost uniform in a layer of finite depth. This might occur, for example, (1) in the boundary layer of high-speed aircraft; (2) in the region between the surface of a blunt body and its shock wave; (3) in local regions near an aircraft when material is being ablated from the surface; or (4) in the ionosphere wherein air is ionized by radiation from the sun (ref. 41) and is then a uniform conductor, provided the influence of the aircraft is small. The fact that the layer is of finite thickness causes the equations to be in error at the interface. However, if the conducting layer is relatively thick the equations would serve as a good estimate in the vicinity of the surface.

The second semi-infinite flat plate case which was analyzed, equations (49) and (53), could be thought to correspond to flight over the magnetic poles of the earth or through some

other magnetic field. The electrically conducting fluid could come about by the same processes mentioned in the previous paragraph. As before, the magnetic field strength and electrical conductivity will probably not correspond exactly to the model analyzed. A close approximation is obtained when an aircraft flies through the ionosphere over one of the magnetic poles of the earth (provided the influence of the aircraft on the electrical conductivity of the air and on the magnetic field is small). Since the earth's magnetic field is small ($B_e \approx 4$ lines/sq in. from ref. 42), effects of this type are generally negligible in the lower reaches of the ionosphere. At the higher altitudes the magnetic parameter is large enough to cause a change in the heat-transfer rate but at those altitudes the mean free path is so large that the continuum flow analysis of this report is no longer applicable.

If the air in the boundary layer is ionized by frictional heating, the conductivity of the air will change with distance from the surface (fig. 10). The actual variation to be expected would be difficult to predict theoretically. The

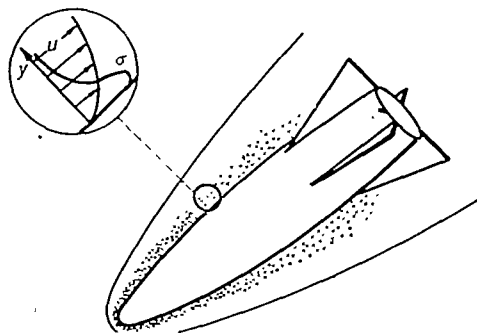

FIGURE 10.—Aircraft moving through the atmosphere at high speed.

solution for a boundary layer with variable electrical conductivity found in a previous section of this paper (eqs. (58), (59), (60), and (64)) and tabulated in table III can be used as an approximate answer. Equation (58) shows that the skin friction can be reduced by a sizable amount at the expense of increased total drag (see eq. (60)). The advantages of using a magnetic field lie in the possibility of reducing the aerodynamic heating, as expressed by equation (64).

The preceding discussion dealt with the advantages that may be achieved by reducing the skin friction, heat transfer, or turbulence. Favorable effects may also be obtained by increasing the displacement thickness of the boundary layer. Such a device, figure 11, could be used on the lower surface of a wing or body to induce forces for lift, control purposes, or drag. The magnitude of these forces is easily changed by increasing or decreasing the field strength which in turn increases or decreases the displacement thickness.

Several additional problems arise when magneto-hydrodynamic effects are used. The system generating the magnetic field will need to be cooled since its parts will dissipate power. Also, the weight of the unit required to generate a magnetic field of sufficient strength may be too large to consider, or of such a size that any advantages are nullified. If the slow moving fluid is hot enough to radiate energy, a sizable quantity of heat may be transferred even though the hot fluid is not in contact with the surface. An

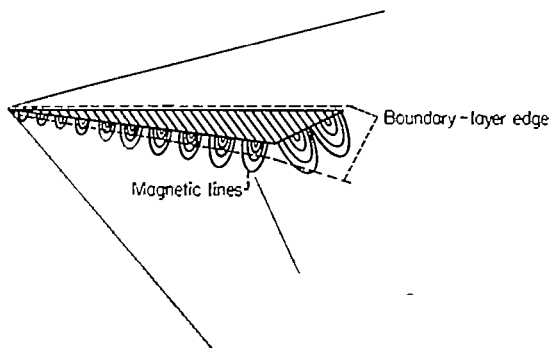

FIGURE 11.—Schematic diagram indicating use of magnetic field to build up the boundary layer on a wing for lift or control purposes.

evaluation of this effect would require a more complete analysis than the solutions developed in this paper.

Whether the applications just discussed can actually be made depends on the magnitude of the quantities entering the parameter m . Consider, for example, an aircraft moving through the upper atmosphere at 25,000 feet per second. From figure 7, a conductivity of not over 5 mhos/inch is to be expected. If ρ/ρ_0 is taken as 10^{-4} , and the above values are inserted into equation (65b),

$$m = 6.43 \times 10^{-10} \frac{5B_0^2}{2.5} \approx 10^{-9} B_0^2$$

In figures 5, 6, and 8, it is seen that the product $m\alpha$ should be of the order of 0.1 for a notable magneto-aerodynamic effect to be brought about. If α is taken as about 100 inches, the magnetic field strength, B_0 , should be around 1000 lines per square inch so that the product $m\alpha$ is equal to 0.1. A magnetic field of such a strength is not unreasonable.

FLOW IN PROPULSION UNITS

The discussion on the reduction of skin friction and heat-transfer rate to the walls of an aircraft by electromagnetic forces applies as well to the internal flow of reaction engines. It may be added that a uniform magnetic field across the jet stream corresponds to the channel flow problems studied in references 8 to 12 and 14. In general, imposing such a field increases the skin friction, equation (49a), and lowers the thrust because of the interference of the magnetic field. A compensating influence is realized through a reduction in turbulence in the stream (see, e. g., refs. 9 and 14) which lowers the skin friction, heat transfer, and probably the noise level of jet engines. Shallow magnetic fields appear to be the most promising for reducing the heat transfer if the flow is nearly laminar.

The cases and illustrations considered so far have assumed that an electric potential E has not been applied across the fluid. To do so would add another force term (see eq. (2)) to equations (7) and (11). If a source of power is available, a combined electric and magnetic field can be used to maneuver the fluid. A possible application would be to use the combined fields to induce an electric motor action to obtain very high exhaust velocities.

CONCLUDING REMARKS

The laminar boundary-layer solutions presented in this paper for the flow of an incompressible electrically conducting fluid over a flat plate indicate the changes that will be brought about by a transverse magnetic field. It has been found that the skin friction and heat-transfer rate are reduced if there is no relative motion between the plate and the magnetic field. The skin friction and heat-transfer rate increased in the case where relative motion was assumed. In all the cases studied the total drag was increased.

The product of the magnetic parameter m and an adjustment distance α is the quantity which determines the effectiveness of the magnetic field to change the heat-transfer rate. Other studies have shown that a magnetic field will in certain cases inhibit transition to turbulent flow and thereby retain a lower heat-transfer rate.

All the cases studied, except one, assume that the conductivity and magnetic field did not change with distance from the surface. A more realistic case of a variable conductivity was considered in one example where a special variation was chosen. The reduction in heat-transfer rate and skin friction for a given value of $m\alpha$ was not as large as when the conductivity was constant. This points out the importance of considering the way in which the conductivity and magnetic field strength change with distance from the surface.

AMES AERONAUTICAL LABORATORY

NATIONAL ADVISORY COMMITTEE FOR AERONAUTICS
MOFFETT FIELD, CALIF., Mar. 13, 1957

REFERENCES

1. Anon.: Pinch Effect. *Scientific American*, vol. 194, no. 2, Feb. 1956, p. 54.
2. Kurchatov, I. V.: Thermonuclear Fusion, Gas Discharge Research in the Soviet Union. *Engineering*, London, vol. 181, no. 4705, May 11, 1956, pp. 322-325.
3. Kantrowitz, Arthur: A Survey of Physical Phenomena Occurring in Flight at Extreme Speeds. *Proceedings of the Conference on High-Speed Aeronautics*. Polytechnic Institute of Brooklyn, Jan. 20-22, 1955, pp. 335-339.
4. Gilmore, F. R.: Equilibrium Composition and Thermodynamic Properties of Air to 24,000° K. The RAND Corp., RM-1543, Aug. 24, 1955.
5. Adler, Fred P.: Measurement of Conductivity of a Jet Flame. *Jour. of Appl. Phys.*, vol. 25, no. 7, July 1954, pp. 903-906.
6. Sanger, E., Goercke, P., and Bredt, I.: On Ionization and Luminescence in Flames. NACA TM 1305, 1951.
7. Chapman, Sydney, and Cowling, T. G.: *The Mathematical Theory of Non-Uniform Gases*. Second ed., Cambridge Univ. Press, 1952.
8. Hartmann, Jul.: Hg-Dynamics I—Theory of the Laminar Flow of an Electrically Conductive Liquid in a Homogeneous Magnetic Field. *Kgl. Danske Videnskabernes Selskab, Matematisk-Fysiske Meddelelser*, vol. 15, no. 6, Copenhagen, 1937.
9. Hartmann, Jul., and Lazarus, Freimut: Hg-Dynamics II—Experimental Investigations on the Flow of Mercury in a Homogeneous Magnetic Field. *Kgl. Danske Videnskabernes Selskab, Matematisk-Fysiske Meddelelser*, vol. 15, no. 7, Copenhagen, 1937.
10. Shercliff, J. A.: Steady Motion of Conducting Fluids in Pipes Under Transverse Magnetic Field. *Proc. Cambridge Philos. Soc.* vol. 49, pt. 1, Jan. 1953, pp. 136-144.

11. Michael, D. H.: Stability of Plane Parallel Flows of Electrically Conducting Fluids. *Proc. Cambridge Philos. Soc.*, vol. 49, pt. 1, Jan. 1953, pp. 166-168.
12. Murgatroyd, W.: Experiments on Magneto-Hydrodynamic Channel Flow. *Philosophical Magazine*, vol. 44, seventh series, no. 353, Nov. 1953, pp. 1348-1354.
13. Stuart, J. T.: On the Stability of Viscous Flow Between Parallel Planes in the Presence of a Co-Planar Magnetic Field. *Proc. Roy. Soc. of London, ser. A*, vol. 221, no. 1145, 21 Jan. 1954, pp. 189-206.
14. Lock, R. C.: Stability of the Flow of an Electrically Conducting Fluid Between Parallel Planes Under a Transverse Magnetic Field. *Proc. Roy. Soc. of London, ser. A*, vol. 233, no. 1192, 6 Dec. 1955, pp. 105-125.
15. Chandrasekhar, S.: The Invariant Theory of Isotropic Turbulence in Magneto-Hydrodynamics. *Proc. Roy. Soc. of London, ser. A*, vol. 204, no. 1079, 9 Jan. 1951, pp. 435-449.
16. Lehnert, B.: The Decay of Magneto-Turbulence in the Presence of a Magnetic Field and Coriolis Force. *Quart. Appl. Math.*, vol. XII, no. 4, Jan. 1955, pp. 321-341.
17. Andrade, E. N. DaC., and Dodd, D.: The Effect of an Electric Field on the Viscosity of Liquids, II. *Proc. Roy. Soc. of London, ser. A*, vol. 204, no. 1079, 9 Jan. 1951, pp. 449-464.
18. Thompson, W. B.: Thermal Convection in a Magnetic Field. *Philosophical Magazine*, vol. 42, seventh series, no. 335, Dec. 1951, pp. 1417-1432.
19. Chandrasekhar, S.: On the Inhibition of Convection by a Magnetic Field. *Philosophical Magazine*, vol. 43, seventh series, no. 340, May 1952, pp. 501-532.
20. Michael, D. H.: Two-Dimensional Magnetic Boundary Layer Problems. *Mathematika*, vol. I, pt. 2, no. 2, Dec. 1954, pp. 131-142.
21. Stewartson, K.: Motion of a Sphere Through a Conducting Fluid in the Presence of a Strong Magnetic Field. *Proc. Cambridge Philos. Soc.*, vol. 52, pt. 2, Apr. 1956, pp. 301-316.
22. Chandrasekhar, S.: The Stability of Viscous Flow Between Rotating Cylinders in the Presence of a Magnetic Field. *Proc. Roy. Soc. of London, ser. A*, vol. 216, Feb. 1953, pp. 293-309.
23. Batchelor, G. K.: On the Spontaneous Magnetic Field in a Conducting Liquid in Turbulent Motion. *Proc. Roy. Soc. of London, ser. A*, vol. 201, no. 1066, 26 Apr. 1950, pp. 405-416.
24. Elsasser, Walter M.: Dimensional Relations in Magneto-Hydrodynamics. *The Physical Review*, vol. 95, no. 1, July 1, 1954, pp. 1-5.
25. Lundquist, S.: Experimental Investigation of Magneto-Hydrodynamic Waves. *The Physical Review*, vol. 76, no. 12, Dec. 15, 1949, pp. 1805-1809.
26. Bullard, Edward (Moderator) and others: A Discussion on Magneto-Hydrodynamics. *Proc. Roy. Soc. of London, ser. A*, vol. 233, no. 1194, Dec. 29, 1955, pp. 289-427.
27. Stratton, Julius Adams: *Electromagnetic Theory*. McGraw-Hill Book Co., Inc., 1941.
28. Schlichting, Hermann: *Grenzschicht-Theorie*. G. Braun, Karlsruhe, 1951.
29. Spitzer, Lyman, Jr.: *Physics of Fully Ionized Gases*. Interscience, 1956.
30. Erdelyi, A., ed.: *Tables of Integral Transforms*. Vol. II, McGraw-Hill Book Co., Inc., 1954.
31. Carslaw, H. S., and Jaeger, J. C.: *Conduction of Heat in Solids*. Clarendon Press, Oxford, 1947.
32. Anon.: *Tables of the Error Function and Its Derivative*. National Bureau of Standards Applied Mathematics, ser. no. 41, 1954.
33. Howarth, L.: Steady Flow in the Boundary Layer Near the Surface of a Cylinder in a Stream. *R. & M. No. 1632*, British A. R. C., July 1934.
34. Hansen, C. Frederick: Approximations for the Thermodynamic and Transport Properties of High-Temperature Air. *NACA TN 4150*, 1958.
35. Kloeffler, R. G., Kerchner, R. M., and Brennehan, J. L.: *Direct-Current Machinery*. The Macmillan Co., 1948.
36. Allen, William A., Rinehart, John S., and White, W. C.: Phenomena Associated With the Flight of Ultra-Speed Pellets. Part I. *Ballistics*. *Jour. Appl. Phys.*, vol. 23, no. 1, Jan. 1952, pp. 132-137.
37. White, W. C., Rinehart, John S., and Allen, William A.: Phenomena Associated With the Flight of Ultra-Speed Pellets. Part II. Spectral Character of Luminosity. *Jour. Appl. Phys.*, vol. 23, no. 2, Feb. 1952, pp. 198-201.
38. Rinehart, John S., Allen, William A., and White, W. C.: Phenomena Associated With the Flight of Ultra-Speed Pellets. Part III. General Features of Luminosity. *Jour. Appl. Phys.*, vol. 23, no. 3, Mar. 1952, pp. 297-299.
39. Allen, William A., and Mayfield, Earle B.: Time-Resolved Spectroscopy of Ultra-Speed Pellet Luminosity. *Jour. Appl. Phys.*, vol. 24, no. 2, Feb. 1953, pp. 131-133.
40. Öpik, E. J.: Meteor Radiation, Ionization and Atomic Luminous Efficiency. *Proc. Roy. Soc. of London, ser. A*, vol. 230, no. 1183, 12 July 1955, pp. 463-501.
41. Hulbert, E. O.: Advances in the Physics of the Upper Air Since 1950. *Naval Res. Lab. Rep. 4600*, Oct. 25, 1955.
42. Anon.: *International Critical Tables*. Vol. VI, McGraw-Hill Book Co., Inc., 1929, pp. 445 ff.