

NATIONAL ADVISORY COMMITTEE FOR AERONAUTICS

# WARTIME REPORT

ORIGINALLY ISSUED  
July 1946 as  
Memorandum Report L6E20

FLIGHT INVESTIGATION TO IMPROVE THE DYNAMIC LONGITUDINAL STABILITY  
AND CONTROL-~~FEEL~~ CHARACTERISTICS OF THE P-63A-1 AIRPLANE

(AAF NO. 42-68889) WITH CLOSELY BALANCED

EXPERIMENTAL ELEVATORS

By Harold I. Johnson

Langley Memorial Aeronautical Laboratory  
Langley Field, Va.

PROPERTY OF NORTHROP INSTITUTE OF TECHNOLOGY



WASHINGTON

NACA WARTIME REPORTS are reprints of papers originally issued to provide rapid distribution of advance research results to an authorized group requiring them for the war effort. They were previously held under a security status but are now unclassified. Some of these reports were not technically edited. All have been reproduced without change in order to expedite general distribution.

L-730

NACA LANGLEY MEMORIAL AERONAUTICAL LABORATORY

MEMORANDUM REPORT

for the

Air Materiel Command, Army Air Forces

MR No. L6E20

FLIGHT INVESTIGATION TO IMPROVE THE DYNAMIC LONGITUDINAL STABILITY

AND CONTROL-FEEL CHARACTERISTICS OF THE P-63A-1 AIRPLANE

(AAF NO. 42-68889) WITH CLOSELY BALANCED

EXPERIMENTAL ELEVATORS

By Harold I. Johnson

SUMMARY

Previous tests of the P-63A-1 airplane showed that when the center-of-gravity range for desirable steady-maneuvering stick force gradients was increased by resorting to experimental elevators of increased aerodynamic balance in combination with a bobweight, the stick forces during rapid control movements became unduly light and the control-free longitudinal short-period oscillations became too lightly damped. In order to improve these control characteristics, a control-feel device was developed which increased the stick force necessary to deflect the stick rapidly without affecting the steady-state stick force characteristics. Briefly, this device consisted of a viscous damping cylinder and a coil spring connected in series between the control stick and the airplane structure. Rapid movements of the stick by the pilot deflected the spring which developed resisting forces on the stick that could subside through action of the damping cylinder if the stick was held steady in any position. Therefore in making a rapid pull-up, for instance, it was expected that the device would supply a stick force proportional to elevator deflection in the initial stage of the maneuver and that this stick force would gradually disappear as the stick force due to the bobweight increased. As a result, the over-all stick force variation would approximate the satisfactory type of force variation obtained with a

conventional unbalanced elevator. With controls free, any rapid oscillation of the elevator caused the spring of the control-feel device to deflect in such a manner that the oscillation tended to damp out.

Flight tests of the device included determinations of the characteristics of the airplane in steady turns, in control-free short-period oscillations, in stick-release pull-ups, and in rapid controlled pull-ups. The tests covered wide ranges of both center-of-gravity location and altitude. Brief tests were also made of a device which supplied a small amount of viscous friction to the elevator control system. Some important results of the tests were the following.

The center-of-gravity range for desirable steady-maneuvering stick force gradients with the experimental elevators and bobweight was  $7\frac{1}{2}$  percent of the mean aerodynamic chord as compared to 3 percent of the mean aerodynamic chord with the production elevators. Furthermore, with the experimental elevators and bobweight, the center-of-gravity range could be increased appreciably beyond  $7\frac{1}{2}$  percent mean aerodynamic chord without encountering steady-maneuvering stick force gradients deviating greatly from desirable values (3 to 8 pounds per g) whereas with the production elevators, excessively heavy or excessively light stick force gradients would occur if the center-of-gravity range was extended much beyond 3 percent mean aerodynamic chord. Addition of the control-feel device to the elevator control system brought about marked improvement in both the control feel and dynamic stability characteristics. At some speeds, the control-feel device increased the stick force necessary to deflect the stick rapidly by a factor between 2 and 3 and caused an otherwise continuous control-free short-period oscillation to damp out within  $1\frac{1}{2}$  cycles. The other device, which supplied a small amount of viscous friction (0.2 pound stick force per inch per second velocity of the stick grip) had no appreciable effect on the control-free dynamic stability.

It was found from the tests that although the control-feel device provided satisfactory control characteristics at a given speed it became less effective at higher speeds. Also, in the form tested, the device did not eliminate stick forces caused by the response of the

bobweight to changes in normal acceleration in rough air. To correct both of these shortcomings it is suggested that the coil spring of the control-feel device be replaced with a small airfoil or flap having prearranged hinge moment characteristics.

The possible application of the control-feel device to an elevator control system with a power booster which normally reduces the pilots effort to zero is pointed out.

### INTRODUCTION

At the request of the Air Materiel Command, Army Air Forces, an extensive flight test program was undertaken to develop elevators for the P-63A-1 airplane which would provide desirable longitudinal handling characteristics over a center-of-gravity range of 10 percent of the mean aerodynamic chord for any altitude between 5000 and 25,000 feet. The production elevators gave desirable handling characteristics for a center-of-gravity range of 3 percent of the mean aerodynamic chord for the specified altitude range. During previous tests, a combination of a highly balanced elevator and a bobweight was developed which provided desirable steady maneuvering stick force characteristics over the specified center-of-gravity and altitude ranges. However, the control-feel characteristics of this elevator were considered unsatisfactory by the pilots, mainly because the large aerodynamic balance necessary made the control oversensitive in rapid disturbances of the stick, whether these disturbances were inadvertent or intentional on the part of the pilot. Also, the use of a bobweight or a large positive floating tendency (which was necessary to raise the general level of the steady-maneuvering stick force gradients) in combination with the large aerodynamic balance, was found to cause poor control-free dynamic stability and undesirable control-feel characteristics when flying through rough air. A discussion of the types of control-feel difficulties encountered may be found in reference 1. Reference 1 suggested the control-feel difficulties associated with the combination of highly balanced elevators and bobweight might be overcome through use of a mechanical device which would increase the control forces only in rapid stick movements.

This report presents the results of flight tests of one such mechanical control-feel device. This control-feel device consisted of a spring and dashpot connected in series between the control stick and airplane structure. The device was tested in combination with an experimental elevator and bobweight which gave unsatisfactory dynamic stability and control-feel characteristics in previous tests. Flight tests were made to determine the effect of the device on the behavior of the airplane during control-free short-period oscillations, stick-release pull-ups, and rapid controlled pull-ups. The tests covered wide ranges of both center-of-gravity location and altitude. Brief tests also were made with a second device to determine the effect of viscous friction on the elevator-free characteristics.

## AIRPLANE, ELEVATOR AND CONTROL SYSTEM

### MODIFICATIONS TESTED

The P-63A-1 airplane is a conventional single-engine propeller-driven fighter-type airplane equipped with tricycle landing gear. A side view of the airplane as flown in the present tests is reproduced in figure 1. A three-view drawing of the test airplane (AFF No. 42-68889) is shown in figure 2. This airplane incorporated the enlarged horizontal tail shown in figure 3. Airplane specifications of general interest and dimensions pertinent to a study of the longitudinal handling characteristics are listed in appendix A.

Figure 3 includes a cross section of the experimental elevators used in the tests. These elevators were covered with fabric and had a rib spacing of  $4\frac{1}{4}$  inches. The

plan form of the experimental elevators was the same as the plan form of standard production elevators; increased aerodynamic balance was achieved by thickening the trailing-edge section to give an included trailing-edge angle of  $18\frac{1}{2}^\circ$ . Standard production elevators had flat

upper and lower surfaces aft of a point near the hinge line and had an included trailing-edge angle of  $13^\circ$ .

Characteristics of the elevator control system are illustrated in figures 4 and 5. Figure 4 shows the

elevator-stick gearing relation. Figure 5 shows the variation in stick force with elevator angle due to addition of the bobweight (dash curve). The force added by the bobweight is seen to vary with elevator position but over the range of elevator angles and airplane attitudes encountered in these tests the bobweight force may be taken as approximately 3.7 pounds pull stick force per g normal acceleration. The data of figure 5 also show that static friction in the elevator control system was about 11 pound.

A diagrammatic sketch of the device to improve the elevator control-feel characteristics is shown in figure 6. As can be seen from this figure, the device consists of a viscous damping cylinder connected to the airplane structure through a coil spring. When the stick is deflected rapidly the resistance to fluid flow through the piston restricts relative motion between the piston and the cylinder so that the spring is forcibly deflected and its resisting force is felt on the stick. When the stick is held steady for any appreciable interval, the piston automatically adjusts itself in the cylinder to the position required for no spring tension. Hence the device acts to increase the stick force necessary to deflect the stick rapidly without altering the steady-state stick force characteristics. Figure 7 contains two photographs of the device mounted in the airplane. As shown by these photographs, provision was made for the pilot to attach or detach the device from the control stick in flight. Hence the pilot was able to make consecutive test runs with and without the device so that data could be obtained under comparable flight conditions.

The mechanical characteristics of the control-feel aid are shown in figures 8, 9, and 10. Figure 8 shows the variation of stick force with elevator position due to the spring in the device, when the viscous damping cylinder is inoperative (piston locked in cylinder). The elevator angle for zero stick force in figure 8 was chosen arbitrarily. If some other elevator angle had been chosen, the slope of the curve would be slightly different because of the slight nonlinearity in the relation between the stick and elevator travel (refer to fig. 4). Figure 9 shows the calibration of the control-feel aid in terms of the rate of subsidence of a rapidly applied stick force. The measurements were made by abruptly releasing the cylinder of the control-feel device from a position with

the spring deflected and the stick chained to the airplane structure. The two curves labelled orifice A and orifice B refer to two different orifice arrangements in the piston of the viscous damping cylinder. From the data of figures 8 and 9 it has been calculated that if the spring was replaced by a rigid member stick forces of about 1.9 and 3.2 pounds per inch per second velocity of the stick grip would be required to move the stick at a steady rate with orifices A and B, respectively. It should be noted here that the quantitative values shown in figure 9 do not necessarily apply to the flight data because of temperature differences. The effect of temperature on the viscosity of the S.A.E. No. 20 damping oil caused marked changes in the rate of subsidence of stick force contributed by the mechanical device. No records of the temperature of the damping fluid were obtained in the flight tests so that a quantitative study of the flight data regarding the transient effect of the control-feel aid on the stick forces was impossible. In this connection, the free air temperature on the ground varied between extremes of 50° and 80° F during the flight tests, with by far the greater number of tests performed when the ground temperature was between 60° F and 70° F. Even in going from 60° F to 70° F the viscosity of S.A.E. 20 oil decreases by about one-third. Pilot's opinions indicated the cockpit temperature did not deviate much from the ground temperature even for the high-altitude flights. In spite of the fact that the data of figure 9 apply only approximately to the flight data, the figure is included to illustrate the characteristic shapes of the curves of stick force subsidence as a function of time. Figure 10 presents a time history of an abrupt deflection and release of the control stick made on the ground at zero airspeed. It is seen that the combination of control system and bobweight inertia and the spring of the device caused an oscillation of the control having a short period (about 0.33 second) and requiring about 2 cycles for complete damping.

For some tests viscous friction was added to the elevator by means of a closed hydraulic cylinder filled with fluid and mounted between the airplane structure and the elevator push-pull tube (fig. 11). Motion of the push-pull tube caused fluid to be pumped from one side of the piston to the other through a restrictor valve in an external by-pass tube. The amount of viscous friction used in the flight tests is defined approximately by the

data shown in figure 12. Because the viscous friction cylinder was exposed to temperature variations the amount of viscous friction it contributed was subject to variation due to changes in viscosity of the damping fluid.

### INSTRUMENTATION

The following quantities were measured with the aid of standard NACA recording instruments: airspeed, pressure altitude, normal acceleration, elevator angle, and stick force.

A special boom extending 1 chord length ahead of the right wing near the wing tip was used for the measurement of airspeed. The static pressure measurements from the pitot-static head were corrected for error caused by the local pressure field around the airplane. Airspeed is defined through this report as

$$V_c = 45.08f_o\sqrt{q_c}$$

wherein

- $V_c$  calibrated airspeed, miles per hour
- $f_o$  sea-level standard compressibility correction factor
- $q_c$  difference between total-head pressure and corrected free-stream static pressure, inches of water

This airspeed corresponds to the reading of a standard Army or Navy airspeed indicator without instrument error which is connected to a pitot-static system free from position error. Under sea-level standard conditions, calibrated airspeed is also true airspeed.

Elevator angles were measured by two instruments. One instrument was connected directly to the elevator; the other instrument was connected to the elevator push-pull tube near the tail. Ground tests indicated errors arising from control system flexibility were negligible for the latter instrument installation.



The elevator stick force was measured by an instrument which recorded the strain in the stick at a position near the bottom of the stick. Because of this arrangement the recorder responded to strains caused by inertia of that portion of the stick above the strain gages. Therefore it should be pointed out that in rapid maneuvers involving abrupt release of the stick, the force at the stick grip actually reaches zero almost instantly even though the recorder may indicate a somewhat slower attainment of zero stick force.

#### EXTENT AND PURPOSE OF TESTS

The flight tests covered the following types of maneuvers in the order of subsequent data presentation.

- A. Steady left turns.
- B. Short-period elevator-free oscillations.
- C. Stick-release pull-ups.
- D. Rapid controlled pull-ups.

The last three of the above types of maneuvers were performed both with and without the control-feel aid.

The foregoing maneuvers were performed at calibrated speeds of approximately 200 and 300 miles per hour. The steady turns were made at 5000 feet altitude for take-off center-of-gravity positions of 25.0, 30.1, and 33.2 percent mean aerodynamic chord and at 25,000 feet altitude for take-off center-of-gravity positions of 23.6 and 33.2 percent mean aerodynamic chord. Because of fuel consumption, the center of gravity moves forward a maximum of between 2 and 3 percent mean aerodynamic chord during flight; however, the center-of-gravity positions accompanying all data shown in this report have been corrected for the effect of fuel consumption. In general, the short-period oscillations and stick release pull-ups were performed for the foregoing center-of-gravity positions at 5000 and 20,000 feet altitudes. The rapid controlled pull-ups were made for the three previously given center-of-gravity positions for 5000 feet altitude but only one set of data was obtained for 20,000 feet

altitude with a take-off center-of-gravity position of 33.2 percent mean aerodynamic chord.

The steady turns were made only in the left direction because preliminary tests showed a negligible difference between the characteristics in left and right turns and the pilot was able to make left turns with greater precision than right turns. For the turns at 200 miles per hour, power for straight, wings-level flight was used; at 300 miles per hour, normal rated power was used and it was necessary to dive the airplane slightly to obtain the calibrated speed, especially for the high-altitude runs. The purpose in making the steady turn tests was to determine the steady-state-maneuvering stability and control characteristics. In the present investigation, the control-free dynamic stability and the control-feel characteristics were measured in some configurations for which the steady-maneuvering stability and control characteristics were unsatisfactory to the pilots. It should be remembered, however, that the only configurations of practical importance are those for which the steady-maneuvering characteristics are desirable. The dynamic characteristics are therefore of less interest in cases where the steady-maneuvering characteristics were unsatisfactory.

The short-period oscillation tests were made according to the usual procedure which consists of abruptly deflecting and releasing the stick from trimmed conditions in straight flight at the chosen speeds (200 and 300 miles per hour). These tests were made to investigate the control-free dynamic longitudinal stability. A theoretical investigation of dynamic longitudinal stability with free controls is given in reference 2.

The stick-release pull-up was used in the present tests because this maneuver had been suggested as a simple means of investigating the control-feel problem. As the name implies, the stick-release pull-up is performed by intentionally trimming the airplane tail-heavy in steady straight flight and then abruptly releasing the stick. Providing the short-period oscillation is damped, the airplane will eventually reach a steady pull-up condition at a normal acceleration determined by the amount of the initial out-of-trim stick force and the steady-maneuvering stick force gradient. Immediately following release of the stick however, both the elevator angle and the normal

acceleration might be expected to overshoot their respective final steady values. The degree of this overshooting would be expected to depend on the aerodynamic balance characteristics of the elevator and on various possible control system modifications just as the control-feel characteristics depend to a large extent on these same variables. For example, in a case where the steady-maneuvering stick force gradient is obtained primarily from a bobweight or a large positive floating tendency of the elevator and the elevator resistance to deflection is low, a large amount of overshooting in stick release pull-ups might be expected to occur. The same combination is known to exhibit poor control-feel characteristics in rapid longitudinal maneuvers or in gusty air. In passing it might be well to point out that the stick-release pull-up corresponds to a theoretical maneuver involving the instantaneous application of a given stick force.

The rapid controlled pull-up is a maneuver in which the stick is moved rearward from trim rapidly and returned to trim equally rapidly and held. At no time during the performance of these pull-ups is the stick released. Two typical controlled pull-ups are shown in figure 13. At each speed tested (200 and 300 mph) controlled pull-ups were made using various rates of control motion ranging from very slow movements of the stick to extremely rapid movements of the stick. The resulting data were analyzed by plotting the ratio of maximum stick force divided by maximum resultant acceleration as a function of the time required to move the stick away from, and return it to, trim. Definitions of the quantities used in analyzing the data are indicated in figure 13. This method of analyzing the data was used also in reference 3 which presents a theoretical study of the aerodynamic factors which affect stick forces in rapid pull-ups similar to the controlled pull-ups used in these flight tests.

Controlled pull-ups were made in the present investigation because it was in similar control motions that the pilots first reported poor control-feel characteristics. Such control motions are normally used to correct small disturbances due to gusty air or to make a fast entry into a steady accelerated turn or pull-up. According to the pilots, when the stick force required to deflect the stick rapidly was too low, it was difficult to predict the airplane response following a rapid movement of the elevator control. This characteristic caused

the pilots to feel uneasy and uncertain even when merely flying the airplane straight and level. The control-feel aid was expected to remedy the lack of stick force in the early stages of a rapid longitudinal maneuver because it was designed to supply an increment of stick force which is essentially in phase with the stick travel for very rapid stick motions.

## RESULTS AND DISCUSSION

### A. Characteristics in Steady Turns

The characteristics in steady left turns of the P-63A-1 airplane incorporating the NACA experimental elevators with a 3.7-pound bobweight are shown in figures 14 through 18. Figure 14 shows the variation of stick force and elevator angle with normal acceleration at 5000 feet altitude for the various center-of-gravity positions tested. Figure 15 is a similar plot for 25,000 feet altitude. In figure 16, the stick force data from figures 14 and 15 have been summarized to show the variation of steady maneuvering stick force gradient with center-of-gravity position. The stick force gradients plotted in figure 16 were obtained from the increments in stick force required to go from 1g to 3g and 4g at 200 miles per hour and 300 miles per hour, respectively. These acceleration ranges were chosen in order to keep within flight conditions where the elevator hinge moments were approximately linear (as indicated by linearity of the stick force versus acceleration curves) and to avoid any extrapolations of the data. Figure 17 shows the elevator angle data of figures 14 and 15 plotted against airplane normal force coefficient. Finally, figure 18 is a summary plot of the data of figure 17 showing the variation of the change in elevator angle per unit airplane normal force coefficient with center-of-gravity location. The slopes of elevator angle versus normal force coefficient plotted in figure 18 are based on the increment in elevator angle required to go from 1g to 3g and 4g at 200 miles per hour and 300 miles per hour, respectively. Therefore the stick-free and stick-fixed maneuver points indicated by figures 16 and 18, respectively, are directly comparable although they are not, in the usual sense, maneuver points for a definite value of the airplane normal force coefficient but rather,

average maneuver points covering most of the range of airplane normal force coefficient tested.

The data of figure 16 indicate why it was necessary to incorporate a bobweight in the control system when the experimental elevators were used. Because of the design loading conditions of the airplane, it was desired to obtain a stick force gradient of at least 3 pounds per g at 25,000 feet altitude with the center of gravity at 30 percent mean aerodynamic chord. It should be noted that the stick-fixed maneuvering stability was positive for these altitude and center-of-gravity conditions (fig. 18). However, because of the small rate of change of stick force gradient with center-of-gravity position and because of the loss in maneuvering stability due to increasing altitude, the center of gravity would have had to be at least as far forward as 22 percent mean aerodynamic chord to obtain 3 pounds per g at 25,000 feet altitude without a bobweight. The use of a large center-of-gravity range ahead of 22 percent mean aerodynamic chord was out of the question because the elevator control available for making minimum speed landings quickly became inadequate as the center of gravity was moved forward from 22 percent mean aerodynamic chord. This situation is typical for a fighter type airplane.

From figure 16 it is seen that the relatively low rate of change of stick force gradient with center-of-gravity position afforded by the experimental elevators provided stick force gradients between 3 and 8 pounds per g between 5000 and 25,000 feet altitudes for a center-of-gravity range of about  $7\frac{1}{2}$  percent mean aerodynamic chord. It might be noted, furthermore, that this center-of-gravity range could be increased appreciably without encountering excessively heavy or excessively light stick force gradients. With the production elevators, the allowable center-of-gravity range for desirable stick force gradients was 3 percent of the mean aerodynamic chord and any appreciable widening of this range led to either excessively heavy or excessively light stick force gradients. The rate of change of stick force gradient with center-of-gravity position for the experimental elevators is 0.38 pound per g per percent mean aerodynamic chord. Previous tests showed that a minimum value of this slope of 1.0 pound per g per percent mean aerodynamic chord was required with the P-63 airplane in order to have

satisfactory control-feel characteristics in the absence of mechanical control-feel.

The hinge-moment parameters of the experimental elevators were estimated with the aid of the 5000 feet altitude data of figures 16 and 18, the dimensions of appendix A, and some of the charts of reference 4. It was found that the rate of change of hinge moment coefficient with elevator deflection  $C_{h\delta}$  was about

-0.0025 per degree. From this value and the difference between the stick-fixed and stick-free maneuver points without bobweight, the rate of change of hinge-moment coefficient with change in angle of attack  $C_{h\alpha}$  was estimated to be 0.0003 per degree. Assuming that a value of  $C_{h\delta}$  of -0.0100 would be obtained for an elevator

without aerodynamic balance, it may be concluded that the experimental elevators had three-quarters of the unbalanced value of  $C_{h\delta}$  balanced out. The results of

earlier tests indicated no more than one-third of the unbalanced value of  $C_{h\delta}$  could be eliminated without

causing noticeable deterioration of the elevator control-feel characteristics of the P-63 airplane. As noted above, the experimental elevators had only a very slight tendency to float against the relative wind when a change in the angle of attack occurred.

## B. Short-Period Oscillation Characteristics

1. Characteristics without bobweight. - Figure 19 shows the short-period oscillation characteristics of the airplane without the bobweight in the control system for forward center-of-gravity positions at low and high altitudes. Figure 19(a) includes data obtained with the control-feel aid attached. Note that in figure 19 and subsequent figures the control-feel aid is referred to as "damper." The steady-maneuvering stick force gradients were about 4 and 2 pounds per g, respectively, for the 5000 and 25,000 feet altitude data shown in figure 19. Although the steady stick force gradients were low, it is seen that the short-period oscillation characteristics of the elevator without control system modifications were satisfactory since the oscillations of both elevator angle

and normal acceleration were completely damped within 1 cycle following release of the control. Addition of the control-feel aid caused the oscillation in elevator angle to persist for  $1\frac{1}{4}$  cycles at 200 miles per hour. However,

this oscillation had a very short period similar to the period of the elevator oscillation caused by the device with the airplane on the ground (fig. 10). Because of the short period, this elevator oscillation did not cause any noticeable airplane response. Of noteworthy interest in figure 19(a) is the very appreciable increase in stick force required to deflect the elevator rapidly when the control-feel device was attached. The stick force to deflect the elevator a given amount was increased by a factor of between 2 and 3. This increase in stick force reduced the "touchiness" of the control. The pilot was able to gage more accurately the acceleration response from a rapidly applied stick force because he had a greater range of stick force to deal with in covering the same range of resultant maximum accelerations.

2. Effect of addition of bobweight.- Figure 20 shows the short-period oscillation characteristics for forward center-of-gravity positions at low and high altitudes with the 3.7-pound bobweight in the elevator control system. With this arrangement the steady force gradients were satisfactorily high, ranging from 8 to 6 pounds per g from 5000 to 25,000 feet altitudes, respectively. Addition of the bobweight which was located near the airplane center of gravity greatly reduced the damping; in fact at high altitudes for 300 miles per hour, addition of the bobweight caused the occurrence of steady undamped short-period oscillations as is shown in figure 20(b). These trends corroborate the theoretical analysis of the effect of both bobweight and altitude as set forth in reference 2. Although no records are presented, the pilot found that the undamped oscillations also occurred at low altitudes at speeds above 300 miles per hour. As the altitude was decreased the calibrated speed for the first occurrence of undamped oscillations increased. Attaching the control-feel device to the stick always resulted in complete damping of the short-period oscillations although approximately  $1\frac{1}{2}$  cycles were required. The

ability of the control-feel device to improve damping of the short-period oscillations is probably explained by the fact that it increased the self-centering tendency of the

control system insofar as rapid control movements are concerned. This change may be likened to an increase in the negative value of the elevator hinge-moment parameter  $C_{h\delta}$ .

It is known from the theory that the parameter  $C_{h\delta}$  has a powerful influence on the damping of elevator-free short-period oscillations. (See reference 2.)

3. Effect of center-of-gravity position.- Figure 21 gives the short-period oscillation characteristics for extreme rearward positions of the center of gravity at low and high altitudes with the 3.7-pound bobweight in the elevator control system. For these runs the steady stick force gradients were still acceptably high since they ranged from about 5 to 3 pounds per g in going from 5000 to 25,000 feet altitudes. Comparison between figure 20 and figure 21 shows that moving the center of gravity rearward had a beneficial effect on damping of the oscillations since in the most critical condition (300 mph, high altitude, damper off) the oscillation damped in 3 cycles instead of being undamped. This experimental result of the effect of center-of-gravity position conflicts with the theoretical results of reference 2 which indicate rearward movement of the center of gravity should reduce the damping slightly.

4. Effect of viscous friction.- Figure 22 gives the short-period oscillation characteristics for forward center-of-gravity positions with the 3.7-pound bobweight and the viscous friction incorporated in the elevator control system. For these tests the steady stick-force gradients ranged from about 8 to 6 pounds per g. Considering the differences in magnitude of the initial disturbances used in the runs of figures 20 and 22, it may be concluded that the addition of viscous friction in the small amount tested did not appreciably effect the short-period oscillation characteristics either with or without the control-feel device attached. In flight conditions where differences were apparent, the configuration with viscous friction possessed a lesser degree of damping. Reference 2 points out that even for forward center-of-gravity positions there may exist a limited range of hinge-moment combinations for which the addition of a small amount of viscous friction is detrimental to damping. In these cases, the use of a large amount of viscous friction probably would be beneficial. Whether or not the use of a large amount of viscous friction would be practical, however, is not known. It seemed probable from



the present tests that if viscous friction had been used in an amount large enough to improve the dynamic stability, the pilots would object to the large resistance to stick motion during such maneuvers as the landing flare.

### C. Stick-Release Pull-Up Characteristics

1. Characteristics without bobweight.- Figure 23 shows the stick-release pull-up characteristics for forward center-of-gravity positions with and without the control-feel aid at low altitudes. For these tests, the steady-turn stick force gradient was about  $4\frac{1}{2}$  pounds per g

which is acceptably high. At higher altitudes or for more rearward center-of-gravity locations, however, this configuration would provide unsatisfactorily low stick force gradients. Figure 23 shows that very little or no overshooting in elevator travel or acceleration response occurred following release of the stick. The absence of overshooting is explained by the facts that, without bobweight, the steady maneuvering stick force gradient resulted almost entirely from the small variation of elevator hinge moment with elevator deflection and the stick-fixed stability was great. In spite of the good characteristics shown in the stick release pull-ups the pilot noted poor control-feel characteristics due to the small self-centering tendency of the control without the control-feel device attached. Therefore it may be concluded that the degree of overshooting in stick-release pull-ups is not always a reliable indication of the control-feel characteristics.

2. Effect of addition of bobweight.- Figure 24 gives the stick-release pull-up characteristics at forward center-of-gravity positions and low altitudes after the 3.7-pound bobweight had been installed. Because of the bobweight, the steady stick force gradient was raised to the desirably high value of about 8 pounds per g for these tests. A comparison between figure 23 and figure 24 shows the effect of the bobweight was to increase appreciably the overshooting of both elevator angle and normal acceleration. This overshooting is a direct consequence of the response of the bobweight as affected by the lag between changes in elevator position and resulting changes in normal acceleration. In the steady pull-up state with free controls, the elevator position is determined by both the bobweight and the elevator hinge-moment parameters

whereas in the instant following stick release, the elevator position tends to be determined solely by the elevator hinge-moment parameters since the normal acceleration does not change appreciably and consequently the effect of the bobweight is not felt. Figure 24 shows that the control-feel device, by slowly dissipating the stored-up energy in the out-of-trim control system, succeeded in eliminating the overshooting in acceleration response which was caused primarily by the bobweight. At high altitudes, addition of the 3.7-pound bobweight caused the occurrence of an undamped short-period oscillation during pull-ups following release of the stick at speeds of 300 miles per hour or more. This typical characteristic is shown in a later figure (fig. 26). When the control-feel aid was used in conjunction with the bobweight however, the undamped oscillation no longer occurred and the airplane appeared to perform a smoother transition from the initial to the final acceleration than it did without any control system modifications.

3. Effect of center-of-gravity position.- Figure 25 presents the stick-release pull-up characteristics for rearward center-of-gravity positions at low altitudes with the bobweight installed. Because of the bobweight, the steady stick force gradient was nearly 6 pounds per g for these tests even though the center of gravity was at a far rearward position. A comparison between figures 24 and 25 indicates that, as was the case in the usual short-period oscillation tests, the oscillations of both elevator angle and acceleration were more highly damped at the rearward than at the forward center-of-gravity positions tested. It may be noted from the 300 miles per hour data of figure 25 that addition of the control-feel aid at the rearward center-of-gravity position reduced the total change in elevator angle and, consequently, the rate of growth of normal acceleration following release of the stick. However, it is also apparent that the control-feel aid did not noticeably reduce the amount of overshooting in acceleration at this extreme rearward center-of-gravity position.

4. Effect of viscous friction.- Figure 26 shows the stick-release pull-up characteristics for a forward center-of-gravity position at high altitudes at 300 miles per hour with viscous friction and the bobweight in the elevator control system. Although comparable data are not shown for the characteristics without viscous friction,

there was no noticeable difference from the characteristics shown by figure 26; the undamped short-period oscillation occurred either with or without the viscous friction cylinder installed. Furthermore, in either case, attachment of the control-feel aid resulted in almost instantaneous damping of the oscillation as is shown in figure 26.

#### D. Characteristics in Rapid Controlled Pull-Ups

1. Characteristics without bobweight.- Figure 27 shows results from rapid controlled pull-ups (similar to those shown in fig. 13) made with the experimental elevators at 5000 feet altitude for forward center-of-gravity positions. A curve from reference 1, depicting results from an airplane which had satisfactory control-feel characteristics, is included on figure 27 and subsequent figures for comparative purposes. The "satisfactory" airplane has a larger chord elevator that has little aerodynamic balance. As was pointed out previously, such an elevator cannot provide desirable steady stick force gradients over a large center-of-gravity range. It may be seen from the data for the P-63 in figure 27 that in all conditions tested, the ratio of maximum stick force divided by maximum acceleration always increased as the rate of stick movement was increased. This trend is to be expected in a condition where the steady stick force gradient is obtained almost entirely from the hinge moment due to elevator deflection because, as the maneuver is made more rapidly, a greater change in elevator angle is necessary to produce the same acceleration response. It may also be seen from figure 27 that attaching the control-feel aid approximately doubled the stick force necessary to produce an acceleration change rapidly. Pilots noted a corresponding marked improvement in the control-feel characteristics. Even though the two curves for the satisfactory airplane and the P-63 with the control-feel aid at 200 miles per hour are nearly identical for rapid stick deflections, the pilot noted that the P-63 had a smaller self-centering tendency of the control stick. This apparent contradiction is explained by the different stick-fixed stability of the two airplanes. For the data shown in figure 27, the satisfactory airplane was tested with the center of gravity about 2 percent ahead of the stick-fixed maneuver point whereas for the P-63, the center of gravity was about 11 percent ahead of the stick-fixed

maneuver point. This difference made it necessary to use considerably more stick travel to produce the same maximum acceleration in the P-63; and since about the same stick forces were required to produce a given maximum acceleration in the two airplanes, it is obvious that the stick force per unit stick travel was lower for the P-63 than for the satisfactory airplane. As will be shown later, when the stick-fixed stability of the two airplanes was comparable, the P-63 with control-feel aid exhibited smaller transient stick force gradients  $\left(\frac{\Delta F}{\Delta g}\right)$  than did the satisfactory airplane.

2. Effect of addition of bobweight.- Data obtained in rapid controlled pull-ups after the bobweight was installed are shown in figure 28. Here it may be seen that the stick-force gradient did not always increase with increasing rapidity of the control motion, especially for the case without the control-feel aid attached. At 300 miles per hour, except for extremely rapid pull-ups (where inertia of the control system had a large effect on the maximum stick force reached) or in very slow pull-ups (approximating the steady maneuvering condition), the stick force gradient was less in the controlled pull-ups than it was in steady turns. This trend is explained by the lag between the increment in stick force due to elevator deflection and the increment in stick force contributed by the bobweight. These two stick force increments are in phase, respectively, with the elevator deflection and the normal acceleration. In the steady-maneuvering condition the two stick force increments occur simultaneously so that their effects are additive but in rapid pull-ups the stick force due to elevator deflection leads the stick force due to bobweight because of the lag in acceleration response following an abrupt elevator deflection. (See fig. 13.) Because the maximum change in angle of attack or normal acceleration lags the maximum change in elevator angle in a rapid pull-up the total stick force may be less than the sum of the maximum stick force increments due to change in elevator angle and change in normal acceleration. Therefore it is possible to have lower stick force gradients in rapid pull-ups than in steady maneuvers if a large portion of the steady stick force gradient is obtained from a bobweight. Also in this connection, a large positive floating tendency of the elevator would have essentially the same effect as the bobweight on the stick force characteristics in rapid pull-ups. (See reference 3.)

It is generally conceded that arrangements which show smaller stick force gradients in rapid than in steady maneuvers are undesirable. Figure 27 indicates the control-feel aid gave a substantial improvement at 200 miles per hour on the undesirable characteristic introduced by the bobweight but the beneficial effect was small at 300 miles per hour. The beneficial effect of the control-feel device at 300 miles per hour could be increased by using a stronger spring and by further restricting the orifice in the viscous damping cylinder. If such a change were made, however, the device would probably cause too heavy stick forces at lower speeds unless provision was made for a variation with speed of the characteristics of the device. Such an arrangement is discussed in a subsequent section of this report.

3. Effect of center-of-gravity position.- Figure 29 shows the characteristics obtained in rapid pull-ups after the center of gravity was moved rearward about 9 percent mean aerodynamic chord. The effect of the center-of-gravity shift was to lower the stick force gradients for all rates of stick motion. Such a trend is to be expected because theory shows that to produce the same maximum acceleration response, the necessary magnitude of elevator motion of a given duration decreases as the center of gravity is moved rearward (reference 5). Incidentally, as regards a comparison between the P-63 and the satisfactory airplane, the data of figure 29 are for conditions in which the two airplanes possessed comparable stick-fixed stability.

4. Effect of altitude.- Figure 30 presents data from rapid controlled pull-ups similar to the data of figure 29 except that the altitude was increased from 5000 to 22,000 feet. The effect of altitude was to lower further the stick-force gradients for all rates of stick motion. This effect is the same as that which would be expected from a further rearward center-of-gravity movement at the low altitude. Hence it appears the effect of altitude on either rapid or steady-state-maneuver characteristics was similar because for either rapid pull-ups or steady turns, an increase in altitude caused a decrease in stick force gradient.

EVALUATION AND POSSIBLE FURTHER APPLICATIONS  
OF CONTROL-FEEL DEVICE

Both on the basis of the results described in the preceding section and on the basis of pilots' opinions it was concluded that the control-feel device tested had a decidedly beneficial effect on the dynamic stability and control-feel characteristics of the P-63A-1 airplane with the experimental elevators and bobweight tested. The characteristics of the airplane in rapid maneuvers, which were definitely unsatisfactory without the control-feel aid, were satisfactory with the control-feel aid installed at speeds up to 200 miles per hour with the exception that stick forces due to the response of the bobweight to rapid changes in normal acceleration in gusty air were not eliminated. With increasing speed the gradually decreasing effectiveness of the device was noticeably apparent so that at 300 miles per hour the characteristics with the control-feel aid installed were not entirely acceptable. Some means of changing the characteristics of the device with changing airspeed therefore appears desirable.

It is to be noted that the device as tested added a given stick force increment for a given instantaneous deflection of the control stick. In the case of an elevator that possesses inherently satisfactory control-feel characteristics, the stick force for a given instantaneous stick deflection (neglecting control system inertia) varies essentially as the square of the airspeed. Hence, in the form tested, it was possible for the control-feel device to be adjusted to give excellent control-feel characteristics at only one speed; at lower speeds the control-force increment from the device was too great and at higher speeds the control force increment was too small. In order to have the force increment from the device vary as the square of the speed it would be necessary to incorporate means for changing, as a function of speed, the stick-centering tendency provided by the spring. This characteristic might be obtained either by use of a suitable mechanical device or by the use of a vane mounted in the air stream to provide the necessary stick-centering tendency. With the vane system it might also be possible to obtain

aerodynamic forces due to angle of attack change that would offset the objectionable stick forces arising from the response of a bobweight to the rapid changes in normal acceleration which occur in gusty air.

It is pointed out that a control-feel device incorporating the improvements suggested might have an important application to a power-boost control in which all forces from the elevator are overcome by the booster system. In this case the proper control feel would be supplied entirely by a control-feel aid and a bobweight so that an irreversible control could be used to actuate the elevator. This arrangement might be desirable for very large airplanes or for airplanes subject to large compressibility trim and stability changes because it would eliminate the need for obtaining close, uniform aerodynamic balance on the elevator control surface.

#### CONCLUSIONS

From an investigation of the longitudinal handling characteristics of the P-63A-1 airplane with highly balanced experimental elevators, a bobweight, and a control-feel aid consisting of a spring and a viscous damping cylinder connected in series between the stick and the airplane structure, the following conclusions were indicated:

1. The experimental elevators and the bobweight provided steady-maneuvering stick force gradients between 3 and 8 pounds per g at any altitude between 5000 and 25,000 feet over a center-of-gravity range of  $7\frac{1}{2}$  percent mean aerodynamic chord as compared to a center-of-gravity range of 3 percent mean aerodynamic chord provided by standard production elevators. Furthermore the allowable center-of-gravity range for the experimental elevator configuration could be increased appreciably without encountering excessively heavy or excessively light stick-force gradients whereas such was not the case for the standard production elevators. However, the control-feel characteristics in rapid maneuvers and the control-free dynamic longitudinal stability of the airplane with the experimental elevators and bobweight were unsatisfactory.

2. The control-feel aid effected marked improvement in both the control-feel characteristics and the control-free dynamic longitudinal stability of the airplane with the experimental elevators and bobweight. Addition of the control-feel aid increased the stick force in a rapid pull-up by a factor of between 2 and 3 in some flight conditions and, with controls free, caused an otherwise undamped short-period oscillation to damp out completely in about  $1\frac{1}{2}$  cycles. The control-feel aid also reduced

overshooting and the rate of growth of normal acceleration following release of the controls with the airplane trimmed tail heavy; these effects were considered to be desirable by the pilot. As a result of the fact that no provisions were incorporated by which the characteristics of the control-feel device were changed with varying airspeed, however, it was found that the effectiveness of the device became inadequate as the airspeed was increased from 200 to 300 miles per hour.

3. Further development work is required in order to make the control-feel aid equally effective at all flight speeds and in order to make it capable of reducing or virtually eliminating undesirable stick forces arising from the response of a bobweight to the rapid changes in normal acceleration which occur in flight through gusty air.

4. The addition of viscous friction to the elevator control system in an amount which caused about 0.2 pound stick force per inch per second velocity of the stick grip had a negligible effect on the control-free dynamic stability characteristics.

Langley Memorial Aeronautical Laboratory  
National Advisory Committee for Aeronautics  
Langley Field, Va.



## APPENDIX A

## GENERAL SPECIFICATIONS AND DIMENSIONS OF AIRPLANE

Name and type . . . . .	Bell P-63A-1 fighter
Engine . . . . .	Allison V-1710-93
Rating:	
Take-off . . . . .	1325 hp at 3000 rpm, 54 in. Hg at sea level
Normal rated . . . . .	1050 hp at 2600 rpm, 43 in. Hg at 10,000 ft
Military rated . . . . .	1180 hp at 3000 rpm, 52 in. Hg at 21,500 ft
Supercharger gear ratio . . . . .	6.85:1
Propeller (special aeroproducts type)	
Diameter . . . . .	11 ft 1 in.
Number of blades . . . . .	4
Engine-propeller gear ratio . . . . .	2.23:1
Fuel Capacity (without belly tank), gal . . . . .	136
Weight empty, lb . . . . .	5910
Normal gross weight, lb . . . . .	7650
Wing loading (normal gross wt), lb/sq ft . . . . .	30.85
Power loading (normal gross wt, 1050 hp), lb/hp . . . . .	7.29
Over-all height (taxiing position) . . . . .	11 ft 4 in.
Over-all length . . . . .	32 ft $8\frac{3}{8}$ in.
Wing:	
Span, ft . . . . .	38.33
Area (including section through fuselage) sq ft . . . . .	248
Airfoil section, root . . . . .	NACA 66,2x-116
Airfoil section, tip . . . . .	NACA 66,2x-216
Mean aerodynamic chord, in. . . . .	82.54
Leading edge M.A.C., in. aft L.E. root chord . . . . .	6.11
Aspect ratio . . . . .	5.92:1
Taper ratio . . . . .	2:1
Dihedral (35 percent chord, upper surface), deg . . . . .	3.67
Root incidence, deg . . . . .	1.30
Tip incidence, deg . . . . .	-0.45

## Horizontal tail:

Span, in. . . . .	175
Total area, sq ft . . . . .	46.92
Stabilizer area, sq ft . . . . .	34.15
Total elevator area, sq ft . . . . .	12.77
Elevator area aft of hinge center line, including tab, sq ft . . . . .	9.85
Elevator area forward of hinge center line, sq ft . . . . .	2.92
Elevator trim tab area, sq ft . . . . .	0.92
Elevator root-mean-square chord aft of hinge center line, in. . . . .	11.72
Distance elevator hinge center line to L.E. of M.A.C., in. . . . .	226.28
Elevator travel from stabilizer, deg down . . . . .	15
Elevator travel from stabilizer, deg up . . . . .	35
Stabilizer incidence from thrust axis, deg up . . . . .	1.1

## REFERENCES

1. Phillips, William H.: An investigation of Additional Requirements for Satisfactory Elevator Control Characteristics. NACA TN No. 1060, 1946.
2. Greenberg, Harry, and Sternfield, Leonard: A Theoretical Investigation of Longitudinal Stability of Airplanes with Free Controls Including Effect of Friction in Control System. NACA Rep. No. 791, 1944.
3. Jones, Robert T., and Greenberg, Harry: Effect of Hinge-Moment Parameters on Elevator Stick Forces in Rapid Maneuvers. NACA ARR No. L4J12, 1944.
4. Gilruth, R. R., and White, M. D.: Analysis and Prediction of Longitudinal Stability of Airplanes. NACA Rep. No. 711, 1941.
5. Gates, S. B.: Proposal for an Elevator Manoeuverability Criterion. Rep. No. Aero 1740, British R.A.E., June 1942.

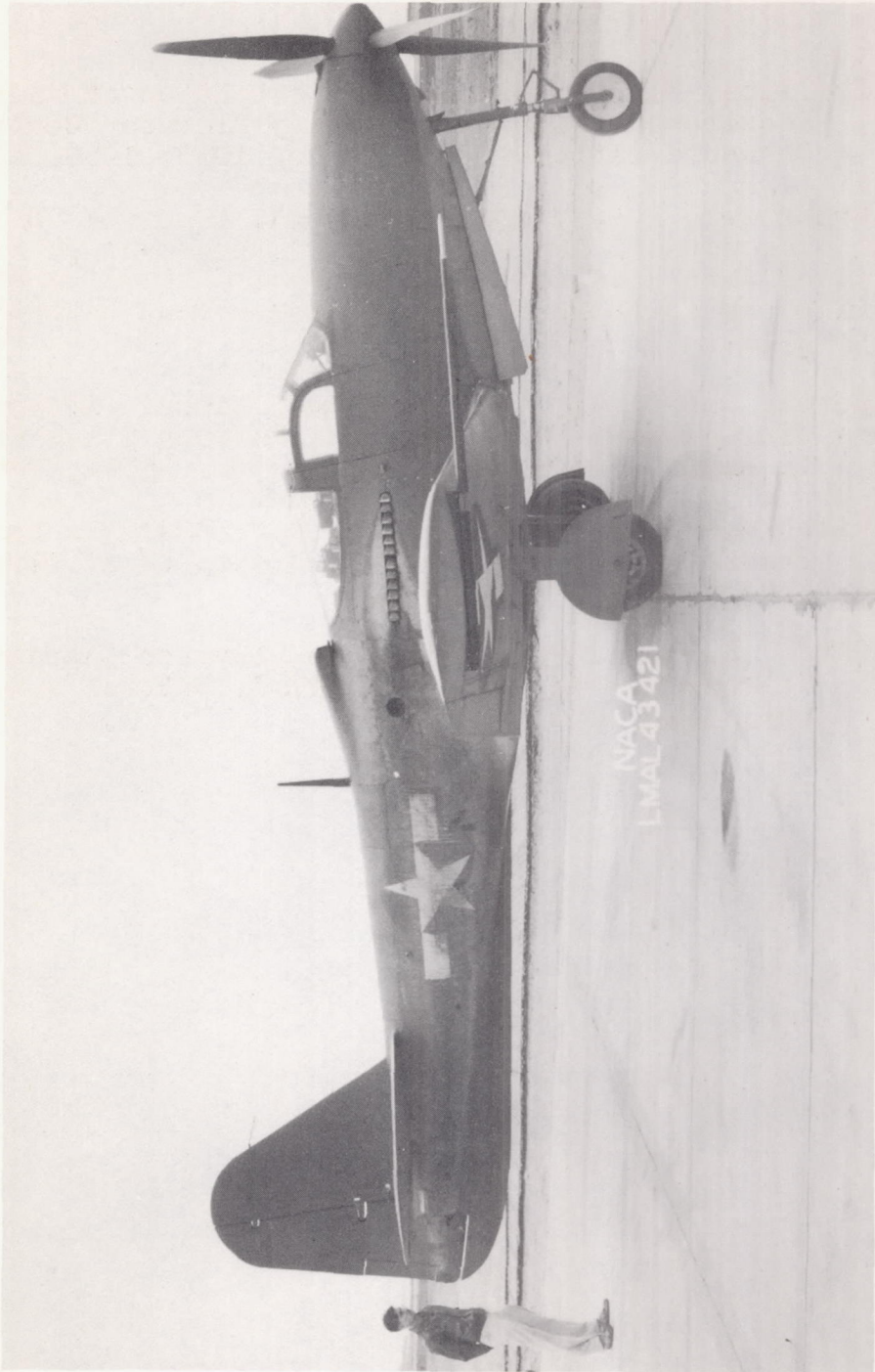
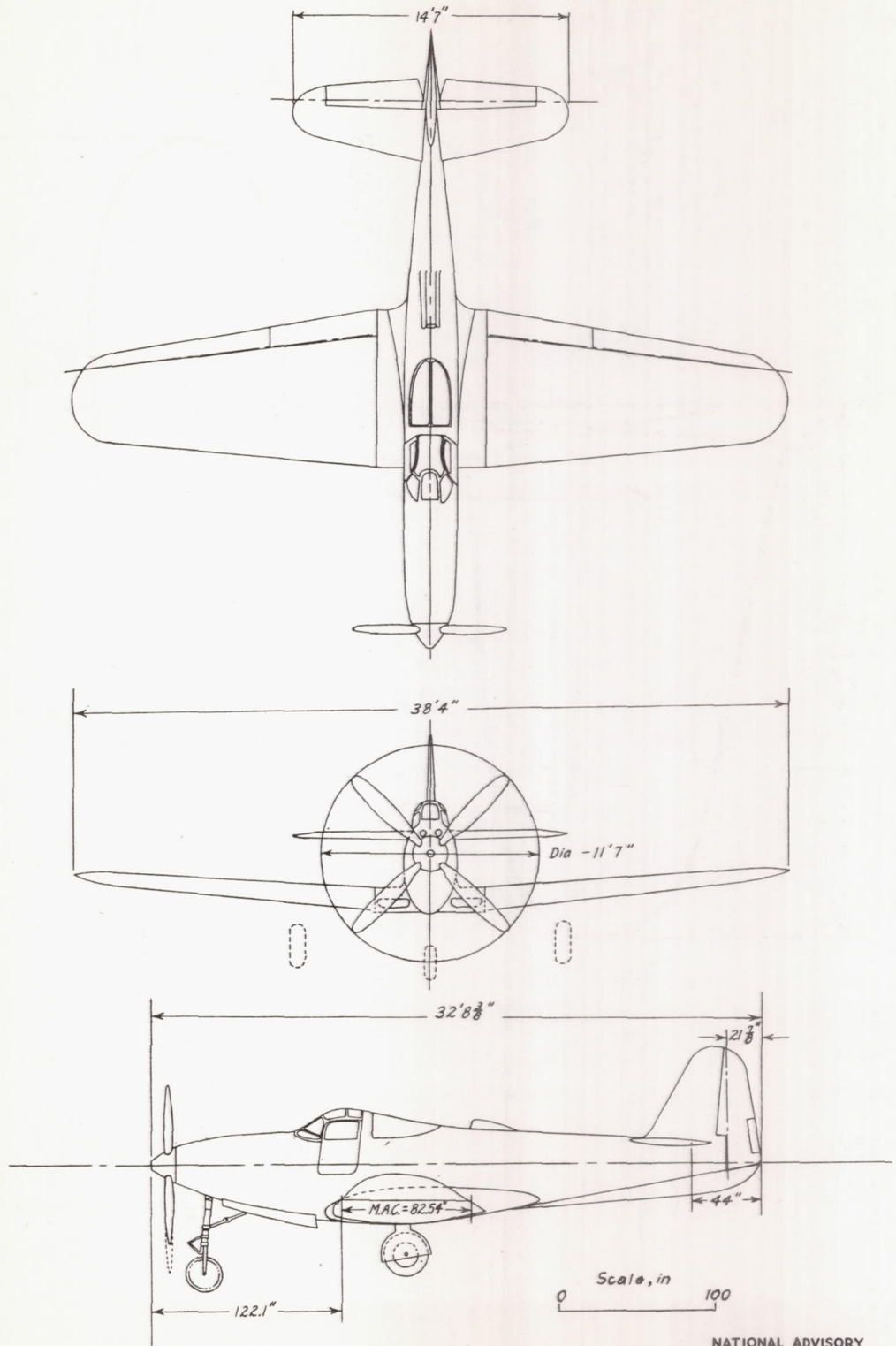

Figure 1.- Side view of Bell P-63A-1 airplane (AAF No. 42-68889).



NATIONAL ADVISORY  
COMMITTEE FOR AERONAUTICS

Figure 2.- Three-view drawing of the P-63A-1 airplane.

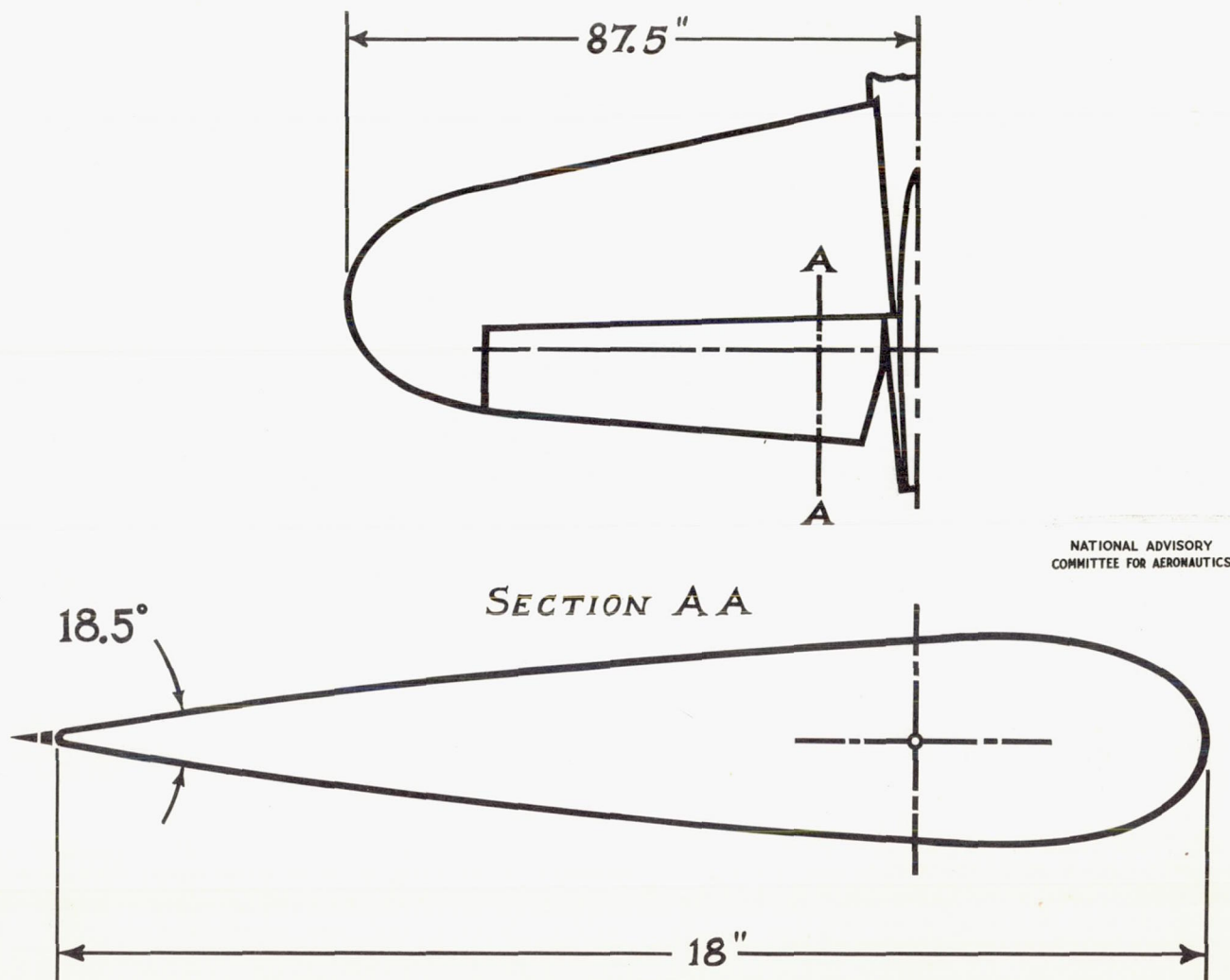

Figure 3.- Planform of horizontal tail and cross-section of experimental elevators tested on P-63A-1 airplane. Section AA located 15 inches from airplane center line.

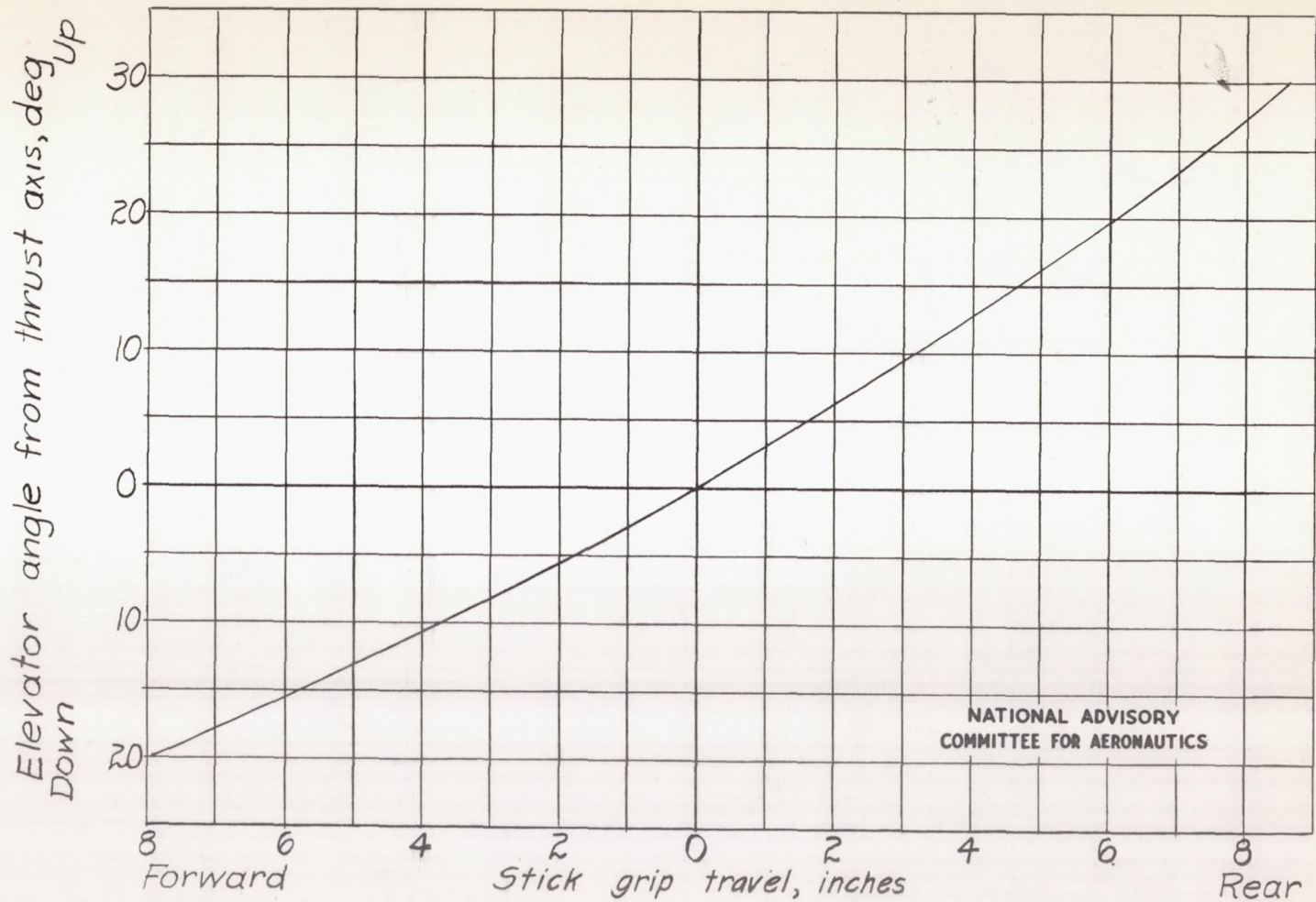

Figure 4.- Elevator-stick gearing relation for P-63A-1 airplane. Effective stick length  $21 \frac{3}{8}$  inches. Slope of curve at zero stick travel is 3.07 degrees elevator angle per inch stick travel.

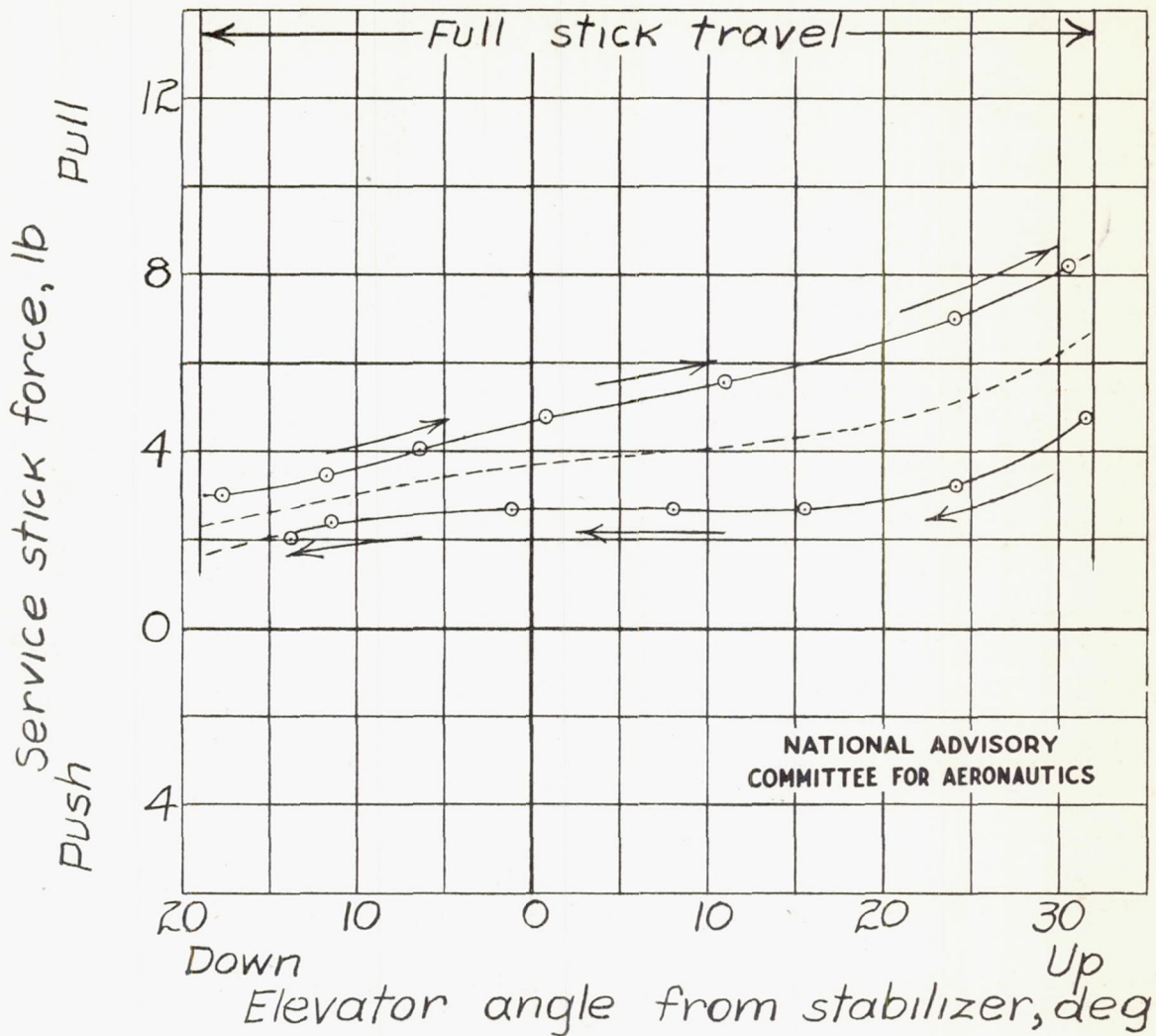

Figure 5.- Variation of stick force with elevator angle for P-63A-1 airplane incorporating bobweight. Thrust axis 8.2 degrees up from horizontal. Stabilizer incidence 41.1 degrees. Service stick force is measured stick force corrected to apply to stick length used in service airplanes.



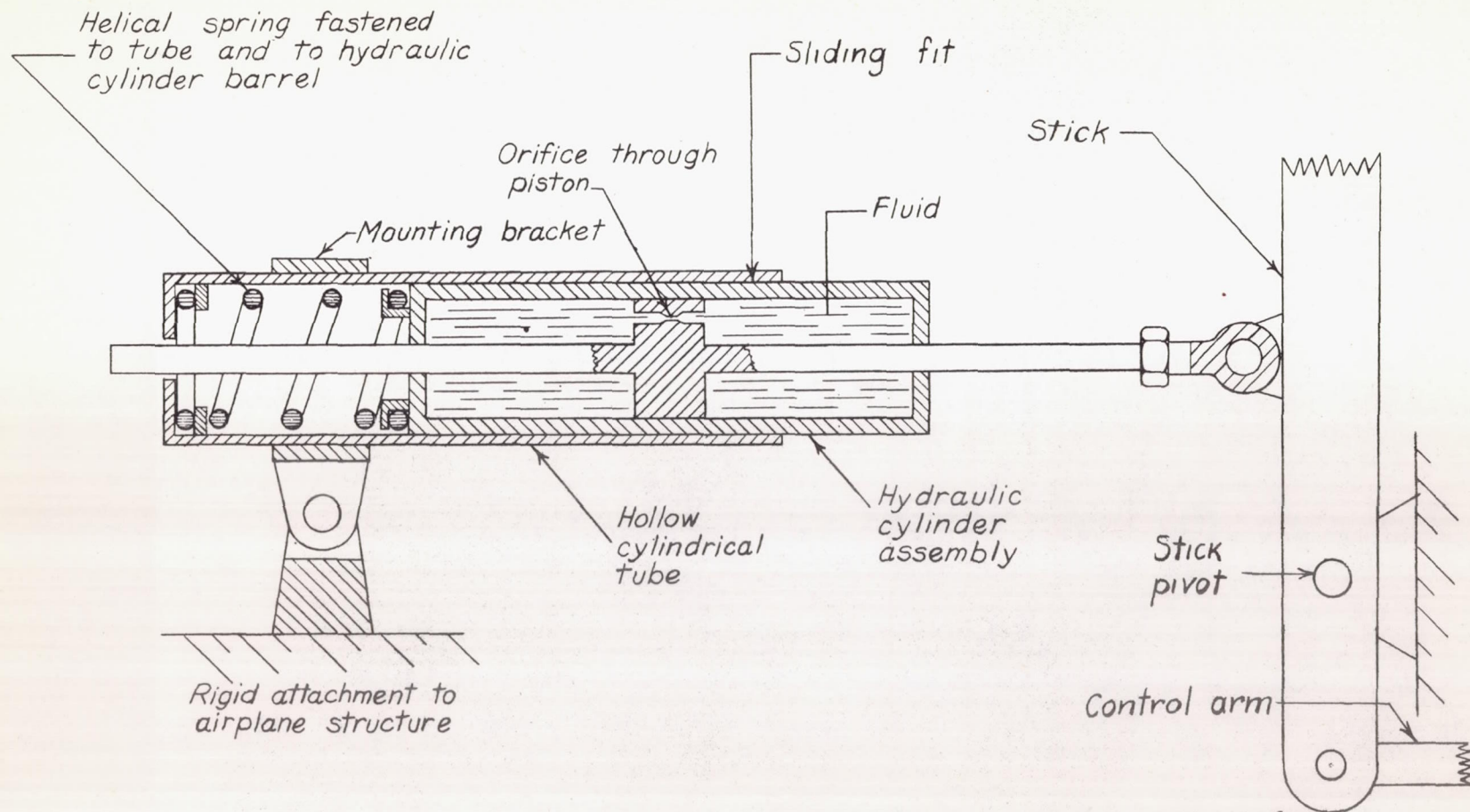
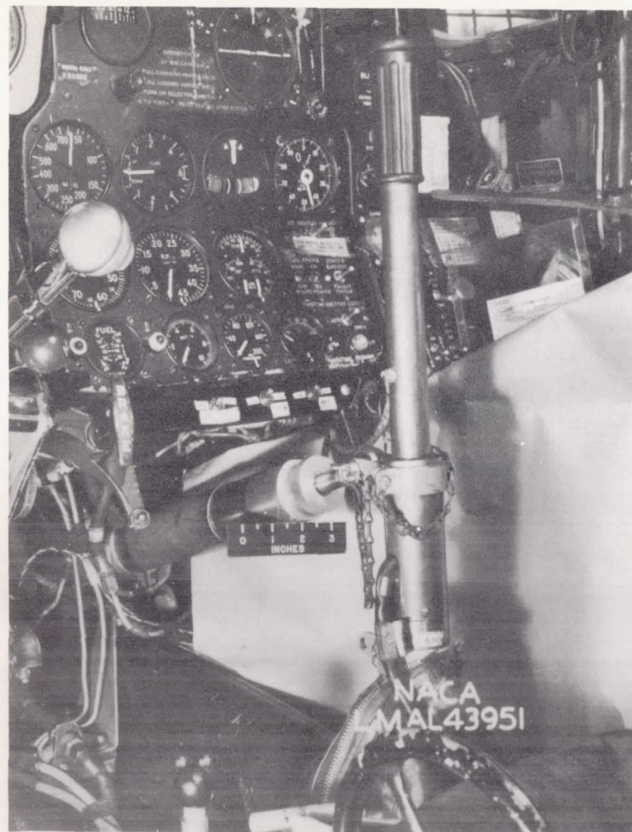
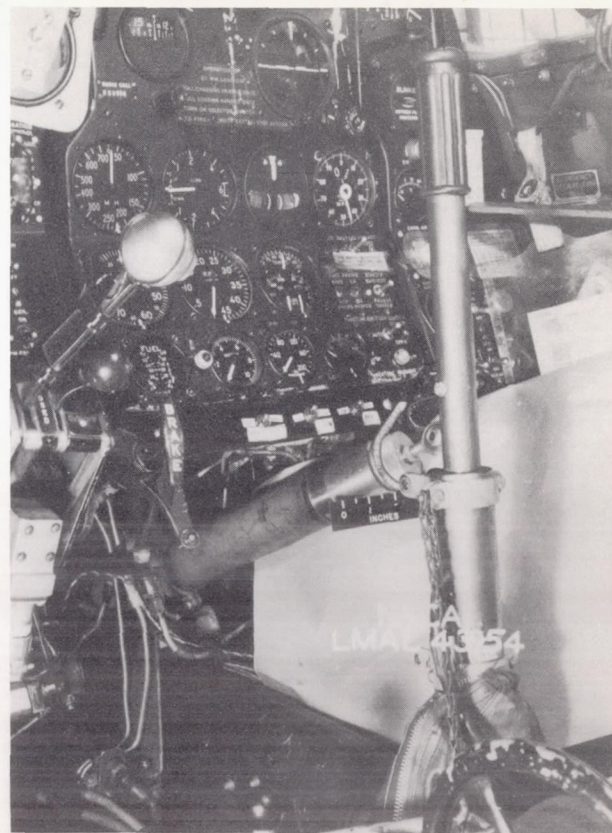

Figure 6.- Diagrammatic sketch of elevator control-feel device tested on P-63A-1 airplane.



(a) Attached to stick.



(b) Stowed.

Figure 7.- Photographs of elevator control-feel device tested on P-63A-1 airplane.

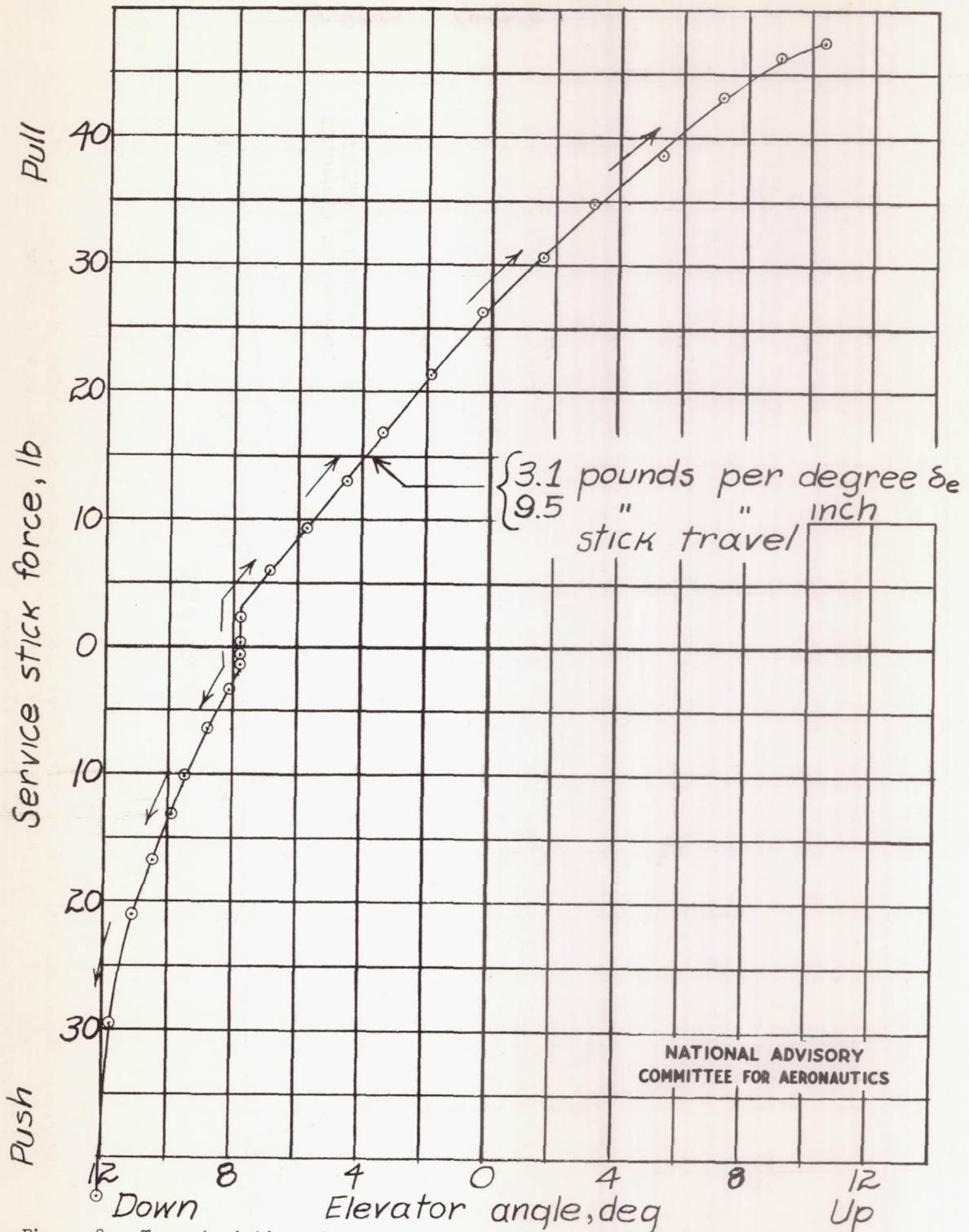

Figure 8.- Characteristics of spring used in damping device. Measurements made with piston locked in cylinder. Arrows along curve show direction measurements were taken. Note discontinuity in curve around zero stick force caused by sum of static frictions of control system and that between cylinder and tube of control-feel device.

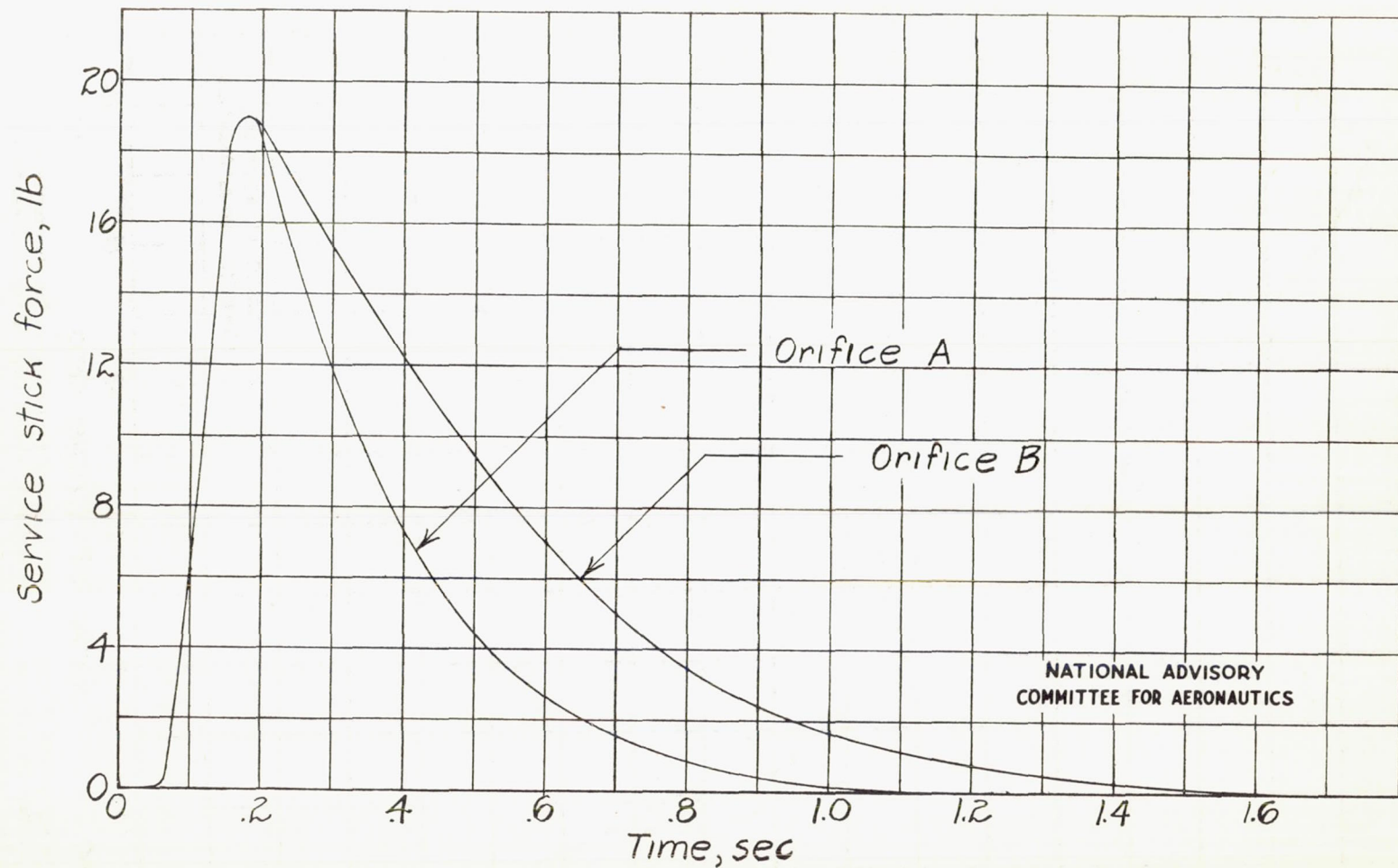
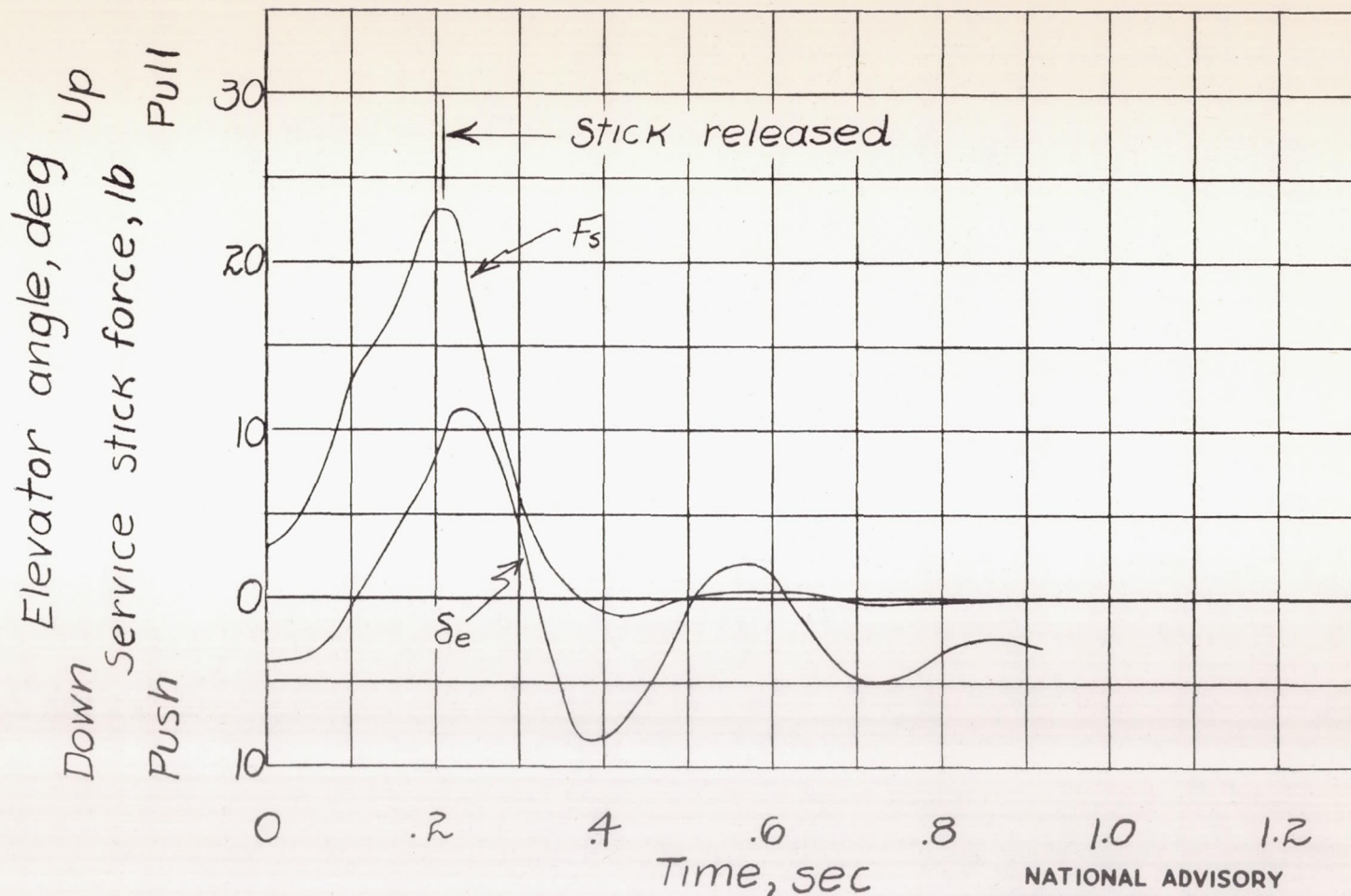

Figure 9.- Variations with time of stick force increment added by control-feel device. Measurements made by abruptly releasing cylinder of device from position with spring deflected and stick chained to airplane structure.



NATIONAL ADVISORY  
COMMITTEE FOR AERONAUTICS

Figure 10.- Simulated short-period oscillation made on the ground at zero airspeed with bobweight and damping device with orifice B attached to elevator control system. Period of elevator oscillation is about 0.33 seconds. Failure of stick force to become zero immediately upon release of stick caused by inertia of portion of stick above force recorder which was located near base of stick.

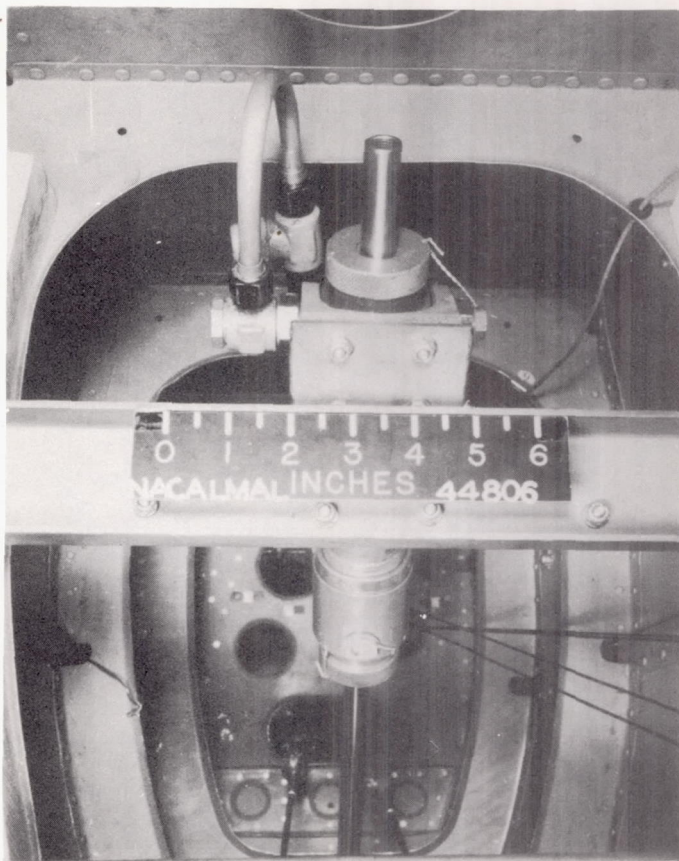

Figure 11.- Photograph of viscous friction cylinder installed in rear of fuselage of P-63A-1 airplane. Elevator control push-pull tube hidden by the lower portions of bulkheads.

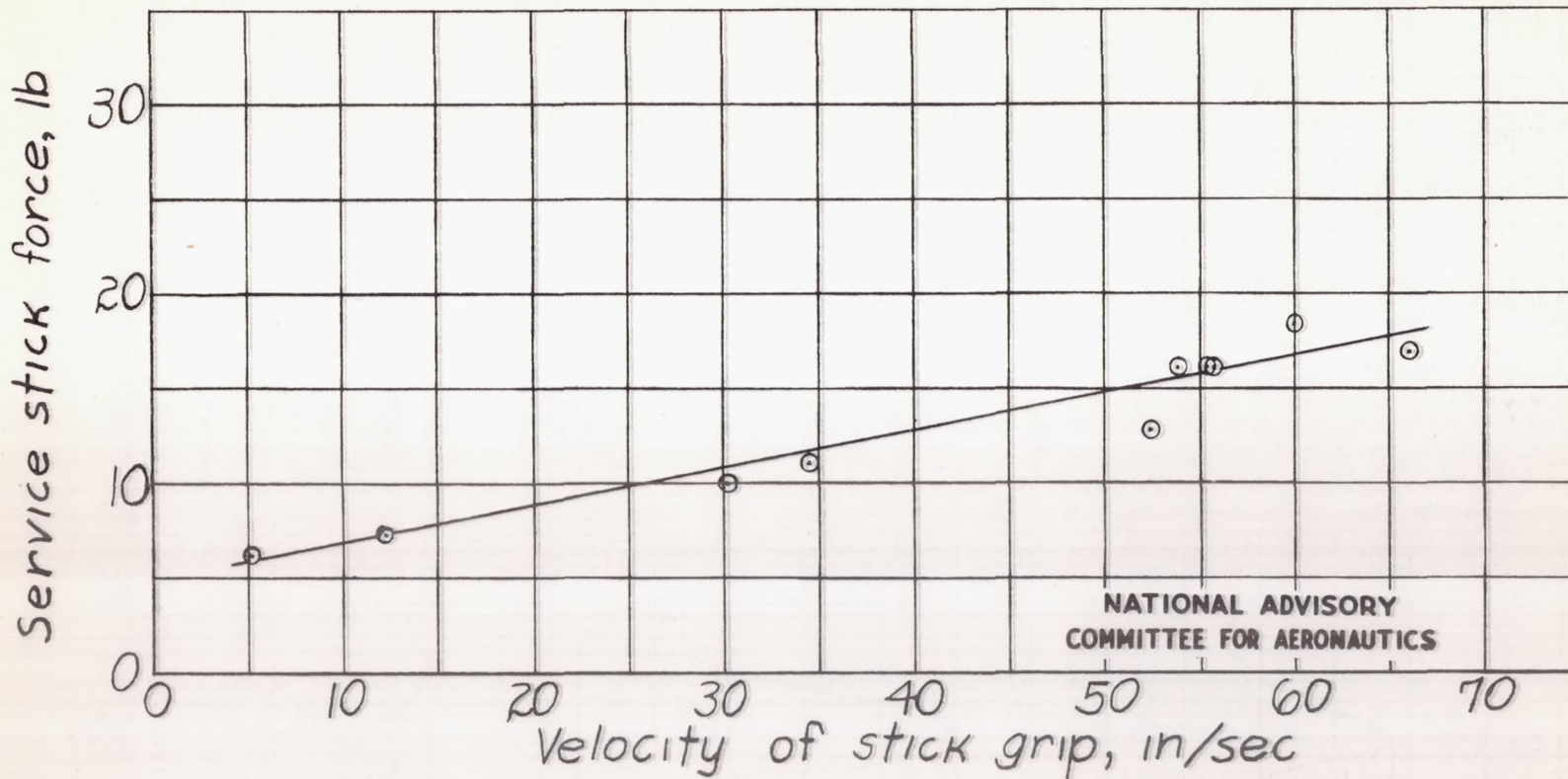
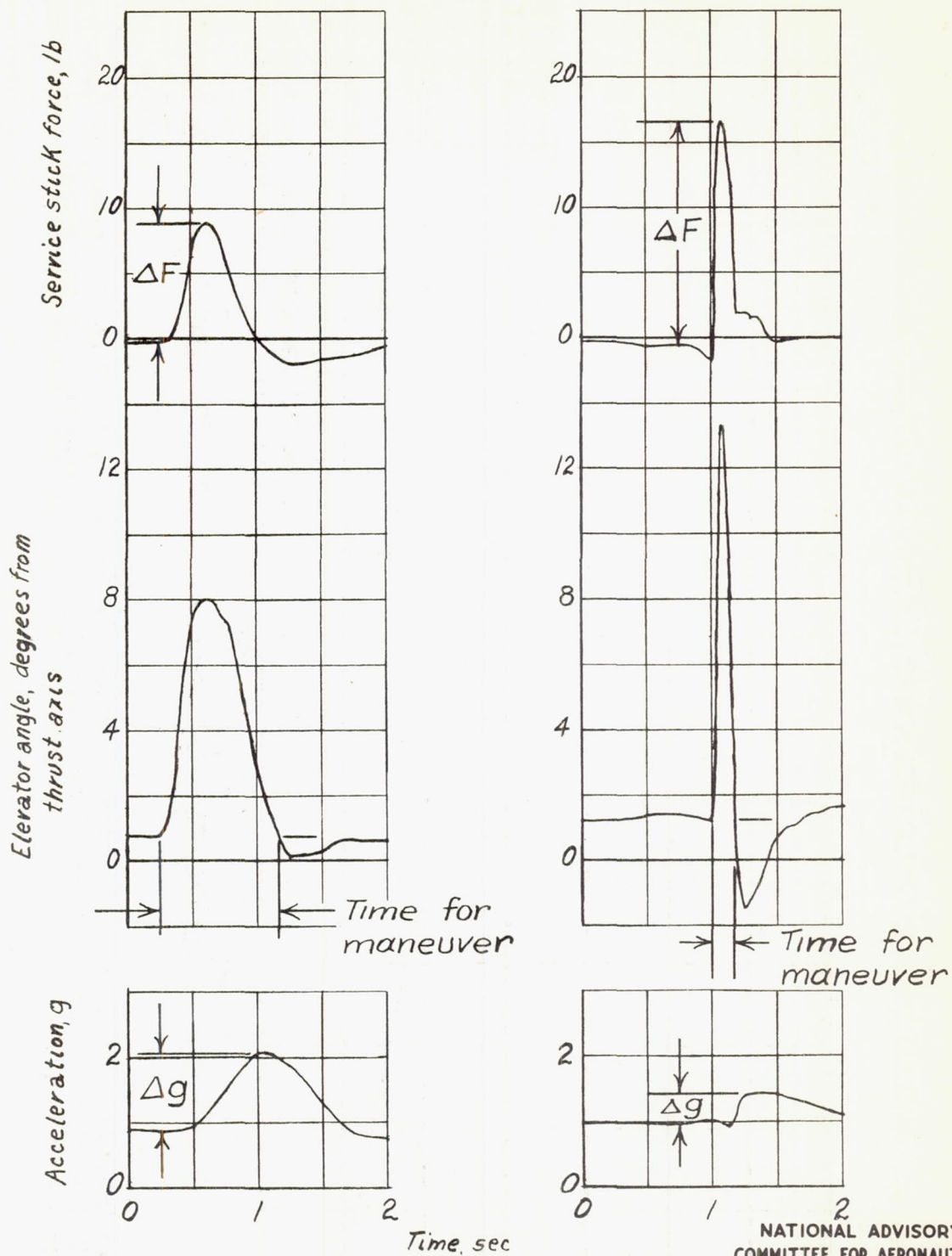

Figure 12.- Determination of amount of viscous friction added to elevator control system of P-63A-1 airplane. Slope of faired line gives 0.2 pound friction per inch per second stick grip velocity.



NATIONAL ADVISORY  
COMMITTEE FOR AERONAUTICS

Figure 13.- Typical examples of rapid controlled pull-ups showing quantities used in analysing data.



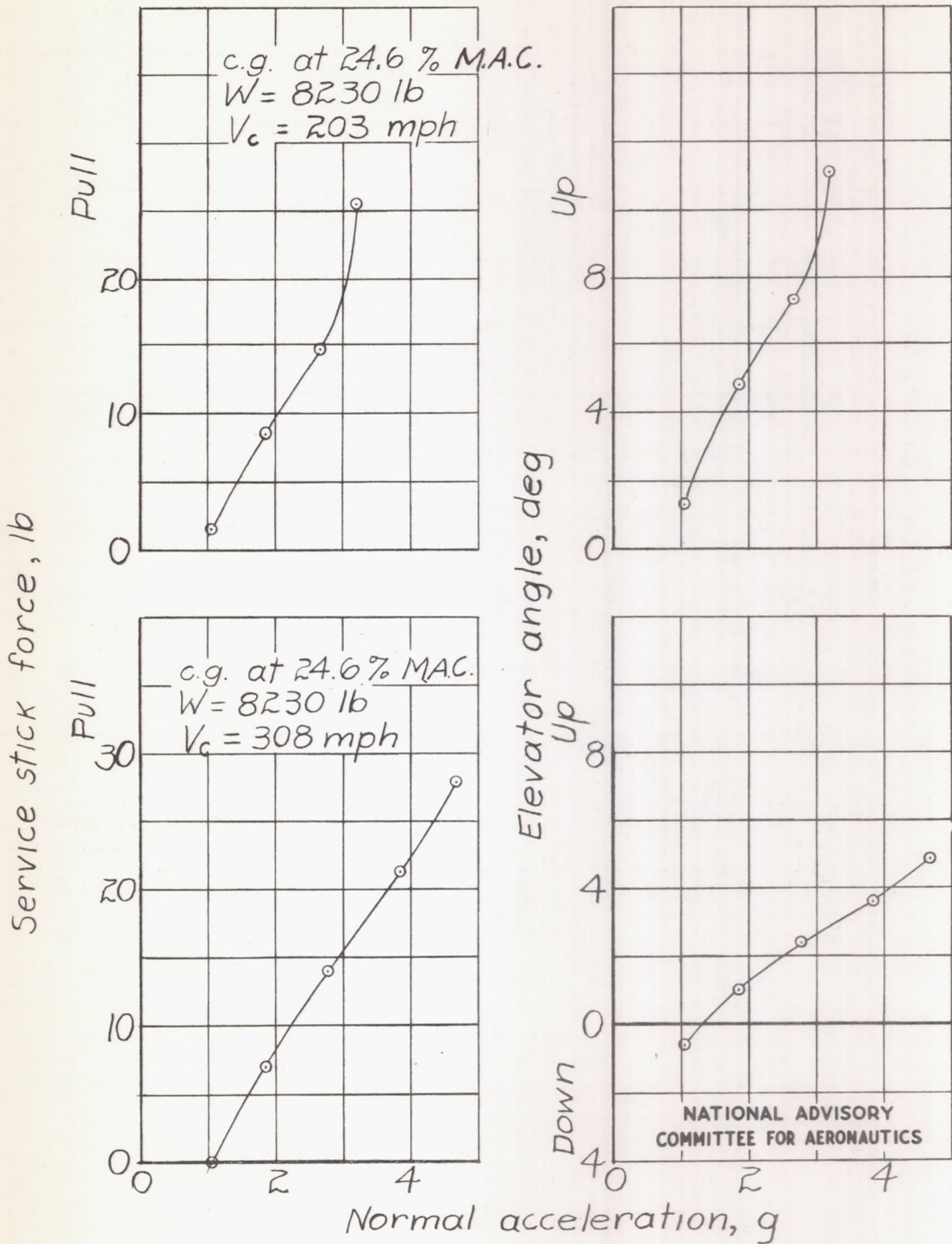

(a) Forward c.g. positions.

Figure 14.- Steady-turn characteristics at 5,000 feet pressure altitude with 3.7 pound bobweight. Power for level flight at 200 mph; normal rated power at 300 mph.

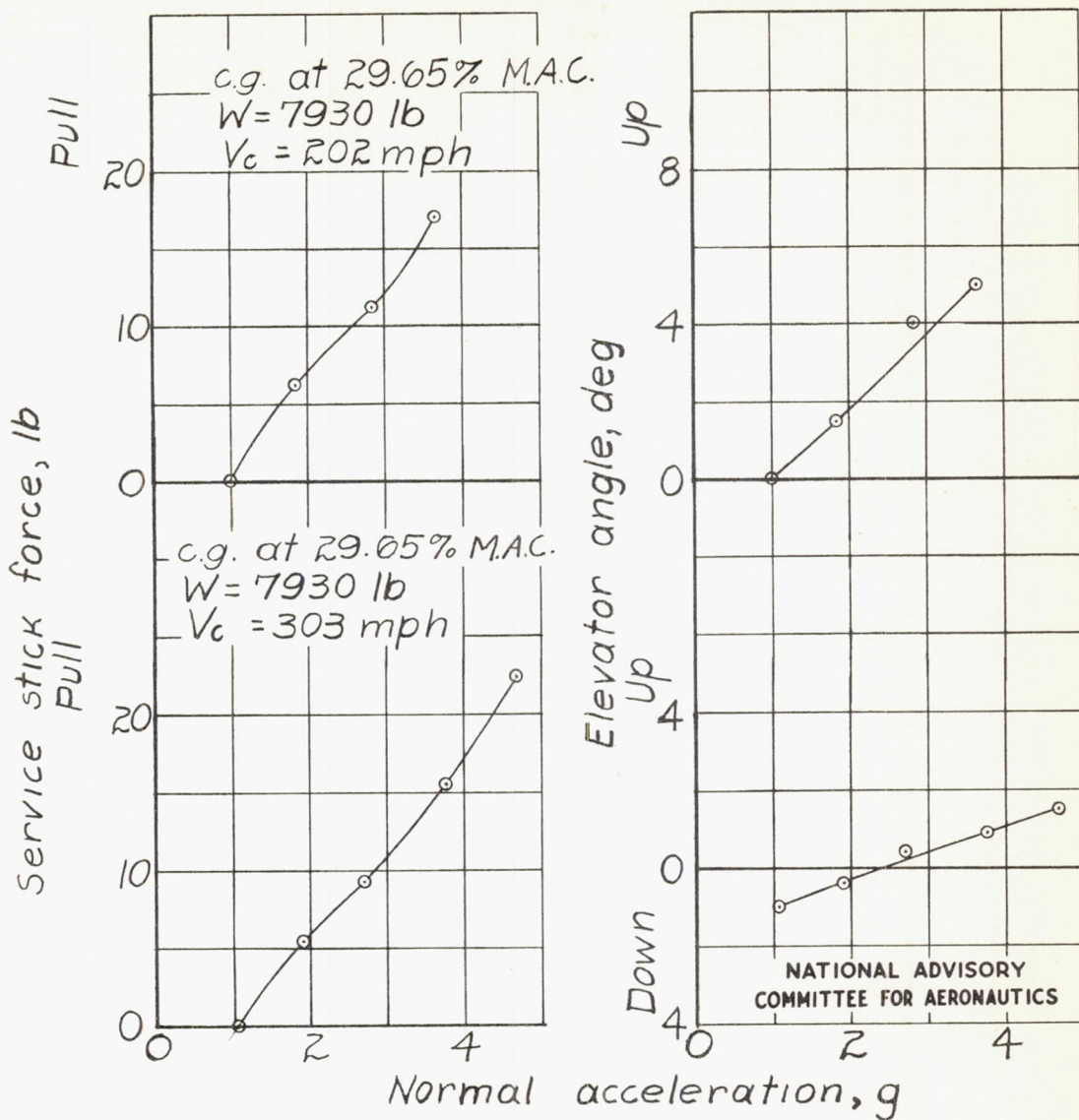

(b) Intermediate c.g. positions.

Figure 14.- Continued.

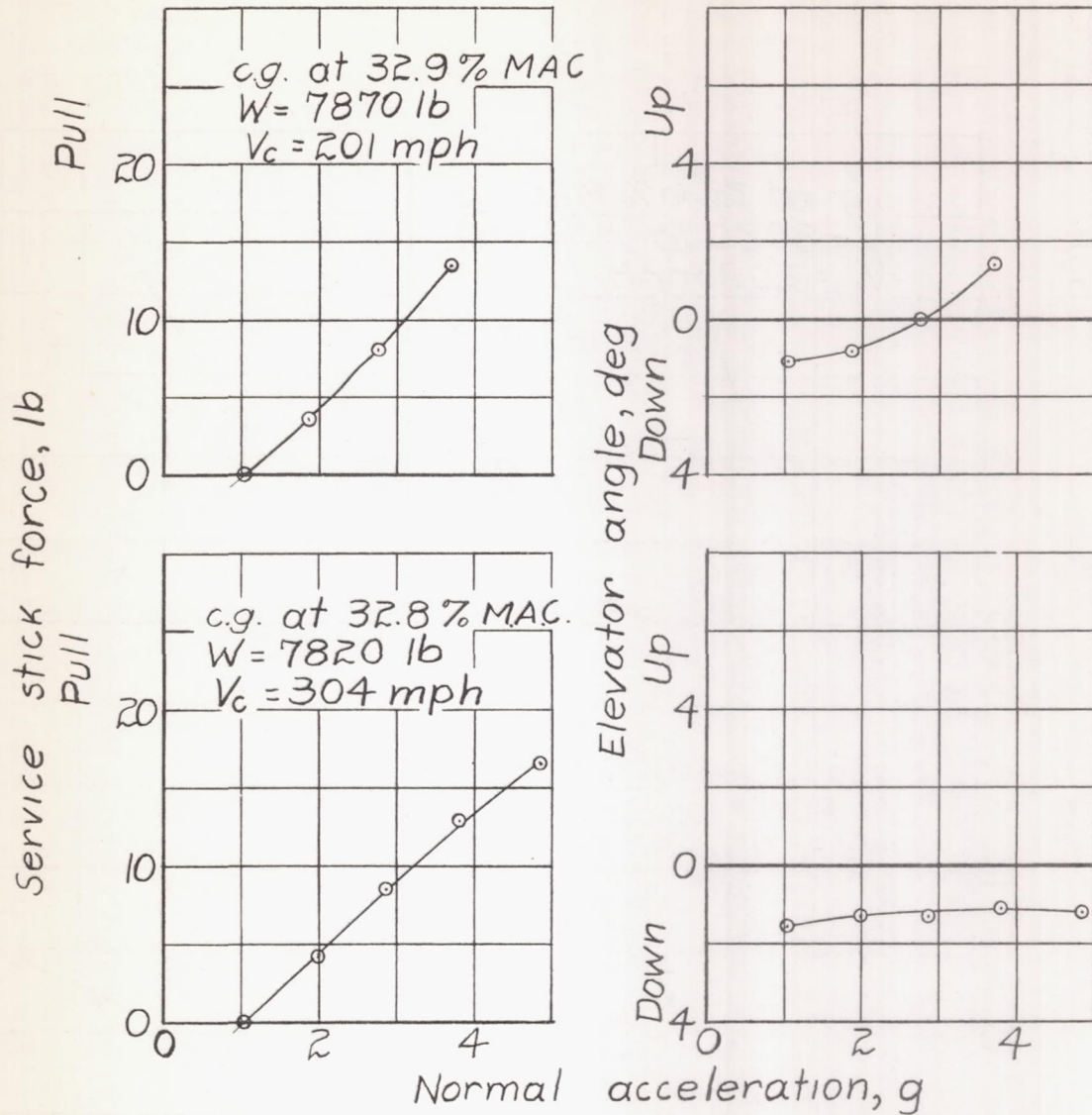

NATIONAL ADVISORY  
 COMMITTEE FOR AERONAUTICS

(c) Rearward c.g. positions.

Figure 14.- Concluded.

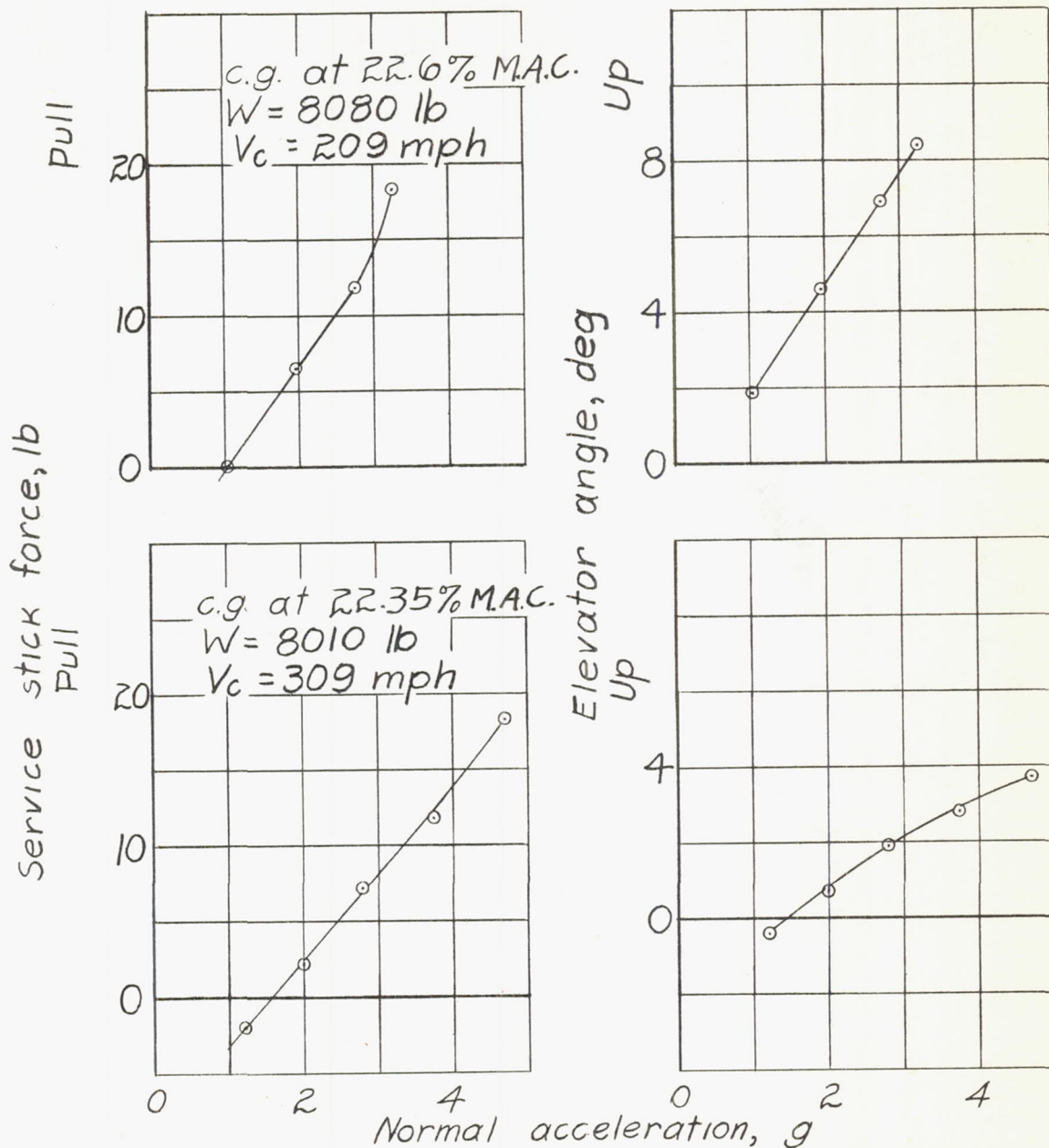

NATIONAL ADVISORY  
 COMMITTEE FOR AERONAUTICS

(a) Forward c.g. positions.

Figure 15.- Steady turn characteristics at 25,000 feet pressure altitude with 3.7 pound bobweight. Power for level flight at 200 mph; normal rated power at 300 mph.

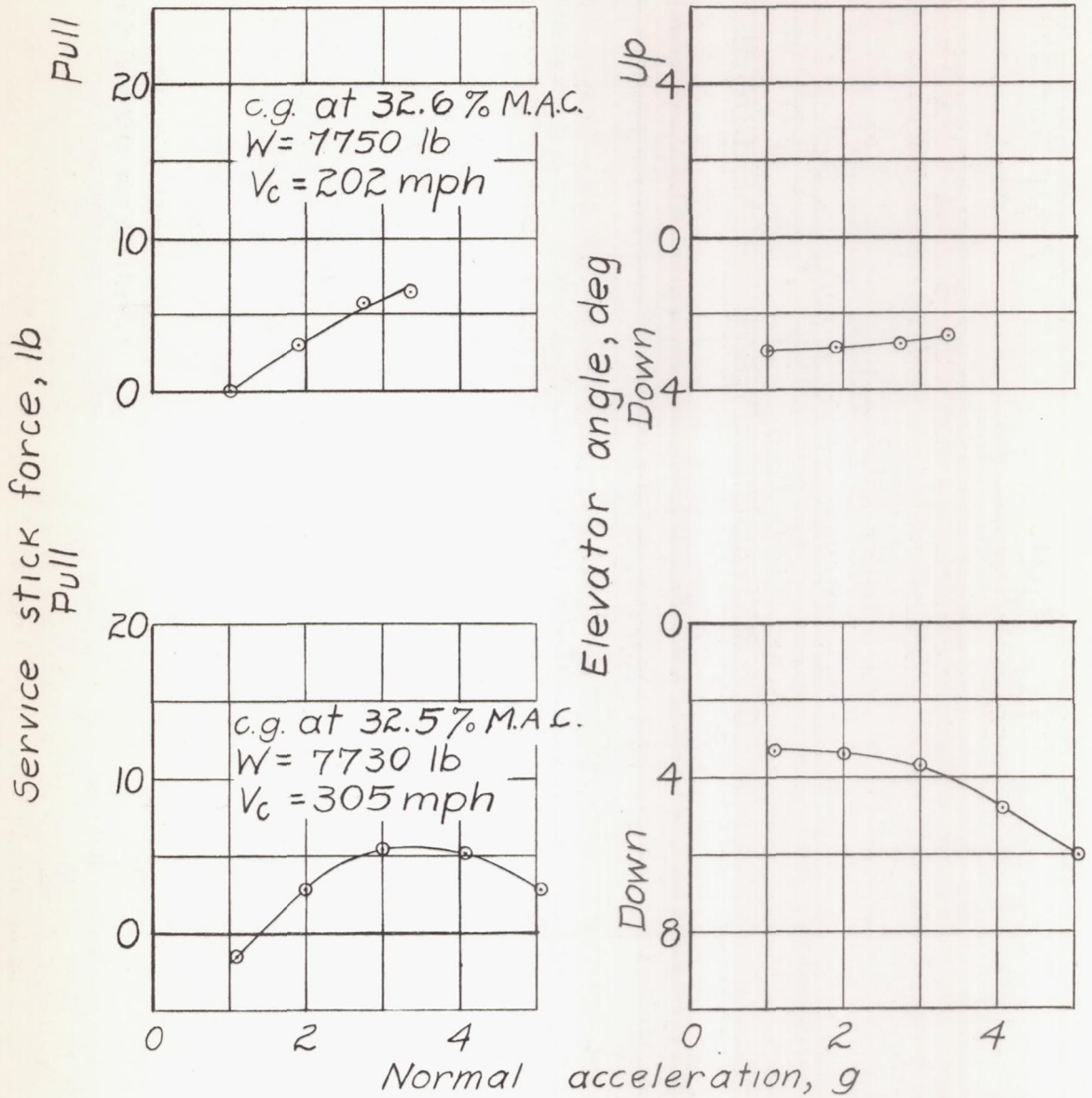

NATIONAL ADVISORY  
COMMITTEE FOR AERONAUTICS

(b) Rearward c.g. positions.

Figure 15.- Concluded.

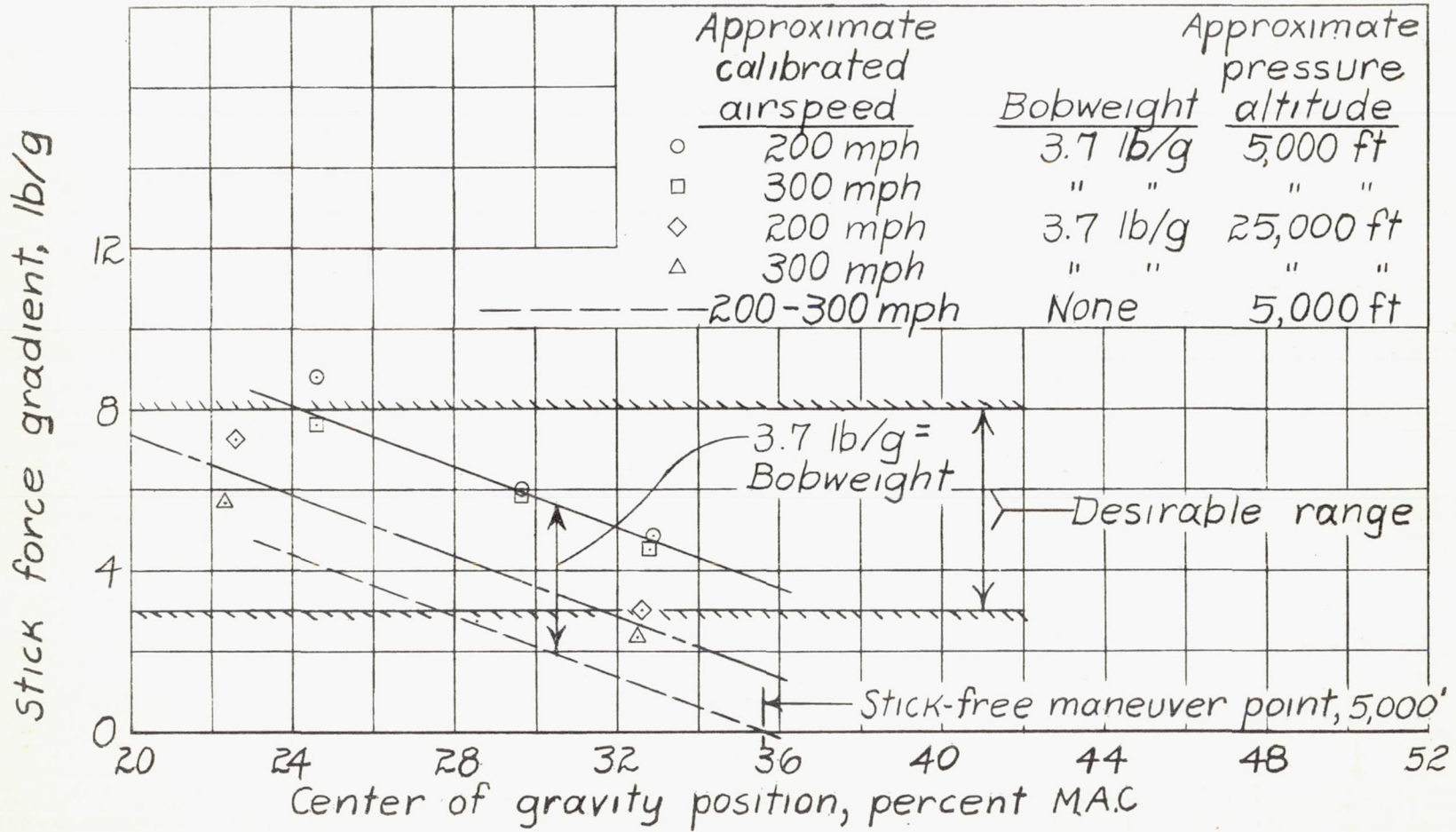

NATIONAL ADVISORY  
COMMITTEE FOR AERONAUTICS

Figure 16.- Stick force gradients in maneuvers as functions of center of gravity position.  
Stick force gradients based on 2g acceleration increment at 200 mph and on 3g acceleration increment at 300 mph.

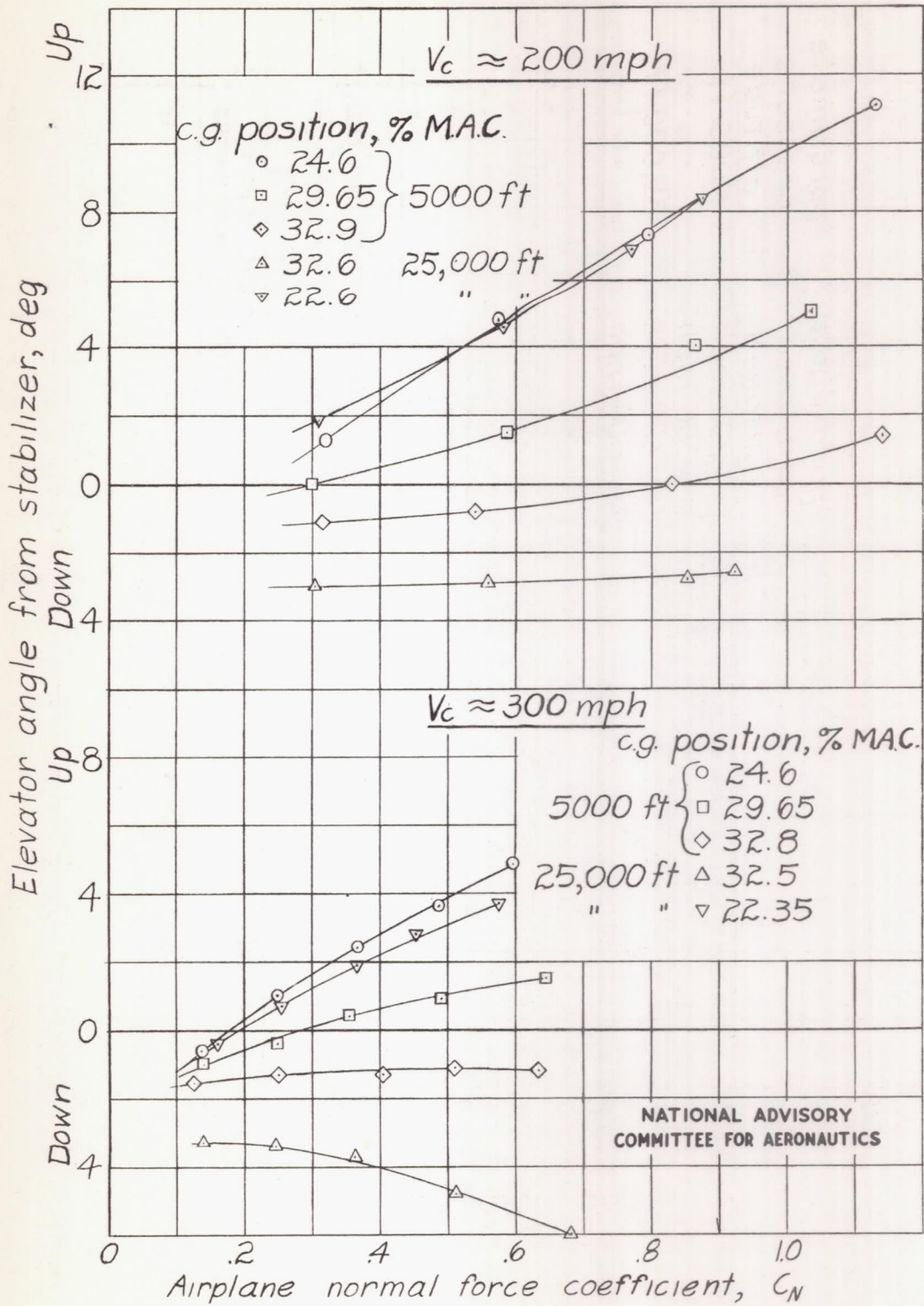

Figure 17.- Elevator angle required in maneuvers as a function of airplane normal force coefficient.

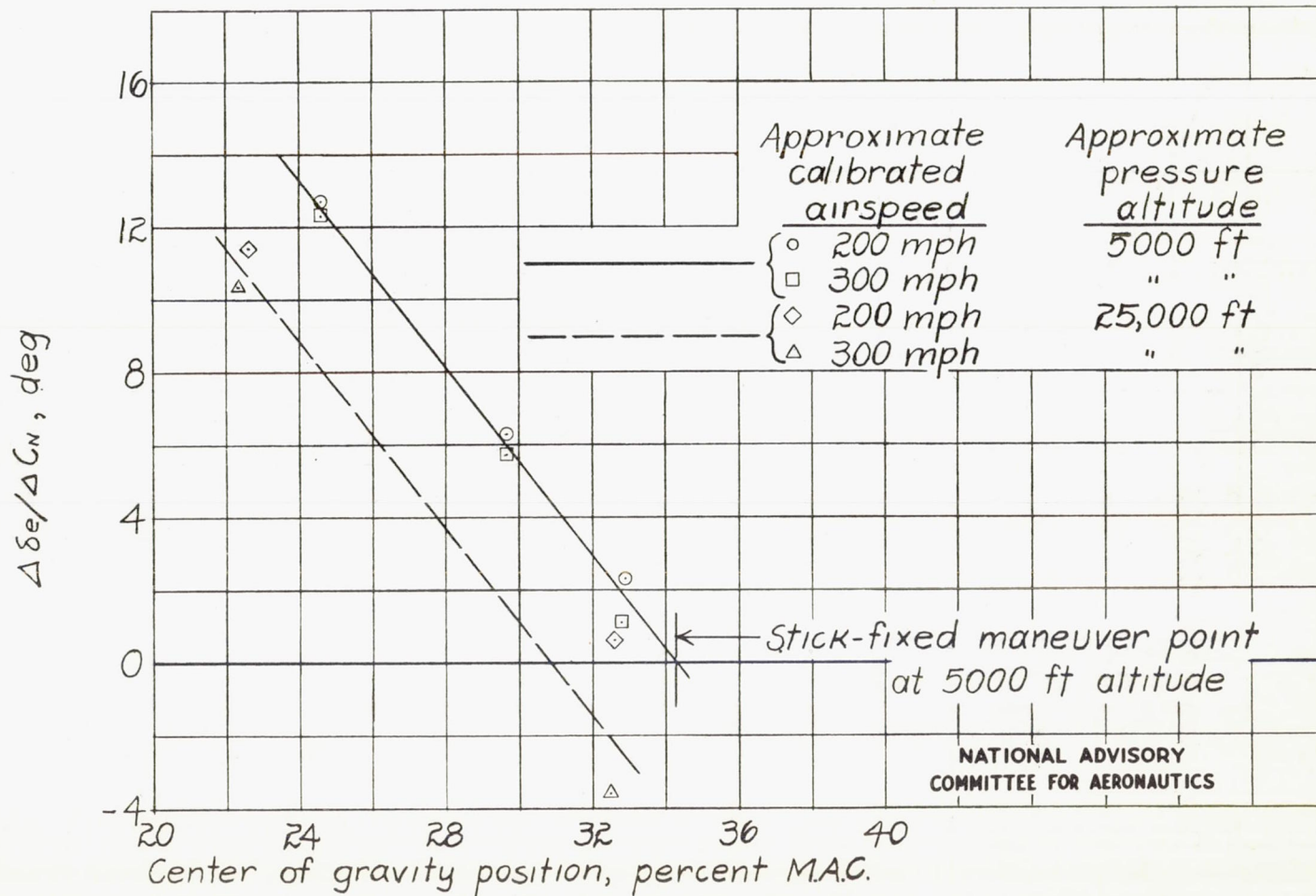
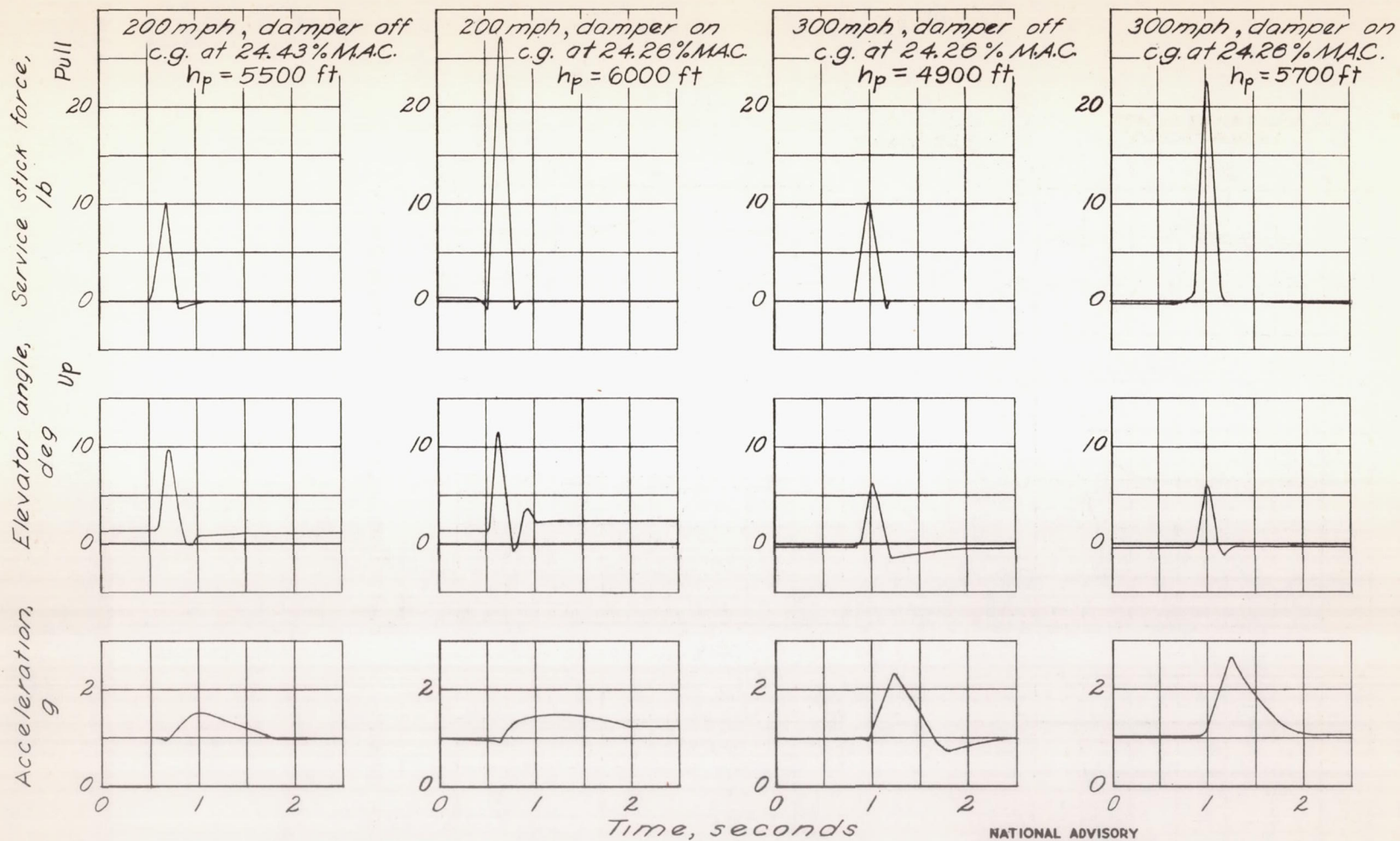

Figure 18.- Stick fixed stability characteristics in steady left turns as a function of center of gravity position. The slopes  $\frac{\Delta\delta_e}{\Delta C_N}$  were measured over  $C_N$  ranges corresponding to 2g increment in normal acceleration at 200 mph and 3g increment in normal acceleration at 300 mph.





(a) Low altitudes.

Figure 19.- Short-period oscillation characteristics Without bobweight. Control-feel device with orifice A.

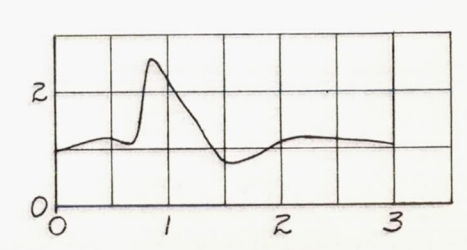
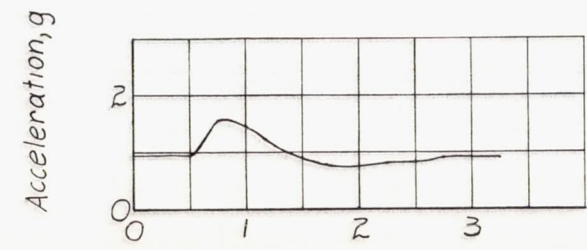
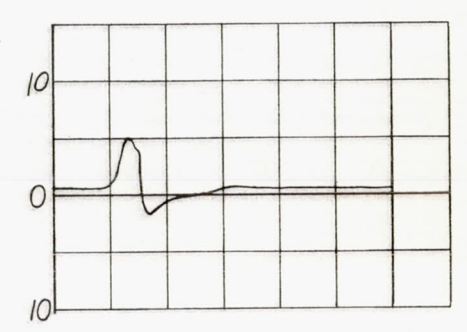
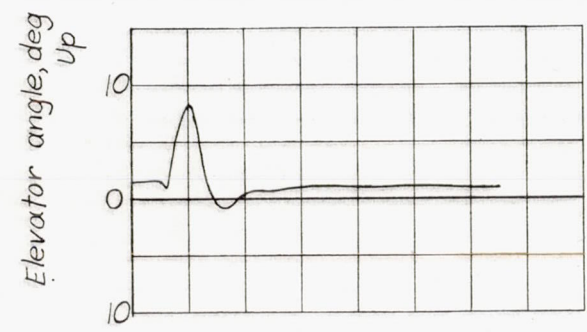
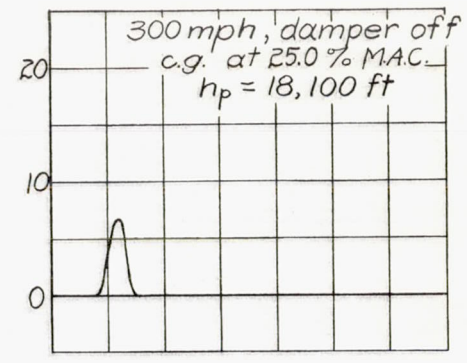
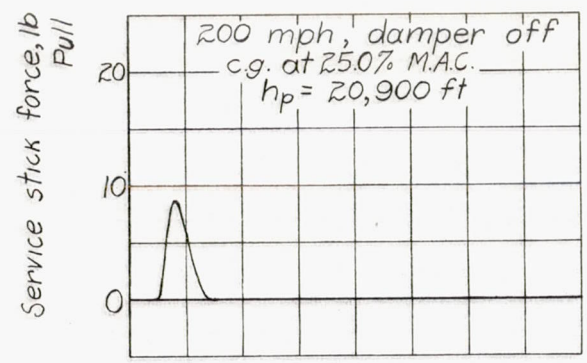

Time, sec

NATIONAL ADVISORY  
COMMITTEE FOR AERONAUTICS

(b) High altitudes.  
Figure 19.- Concluded.

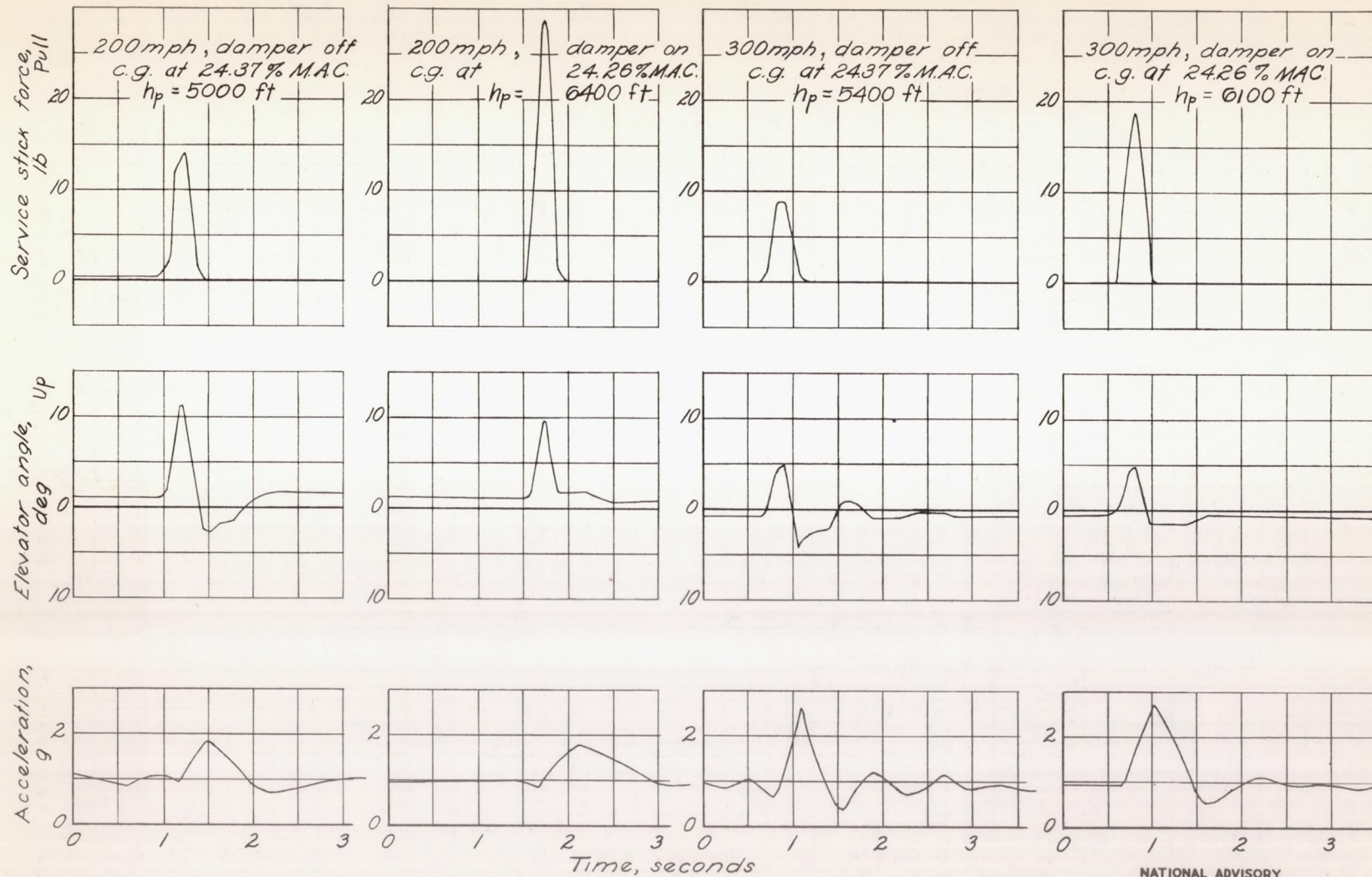

(a) Low altitude. Pilot noted rough air in runs at 300 miles per hour.

Figure 20.- Short-period oscillation characteristics with 3.7 pound bobweight in control system. Control-feel device with orifice A.

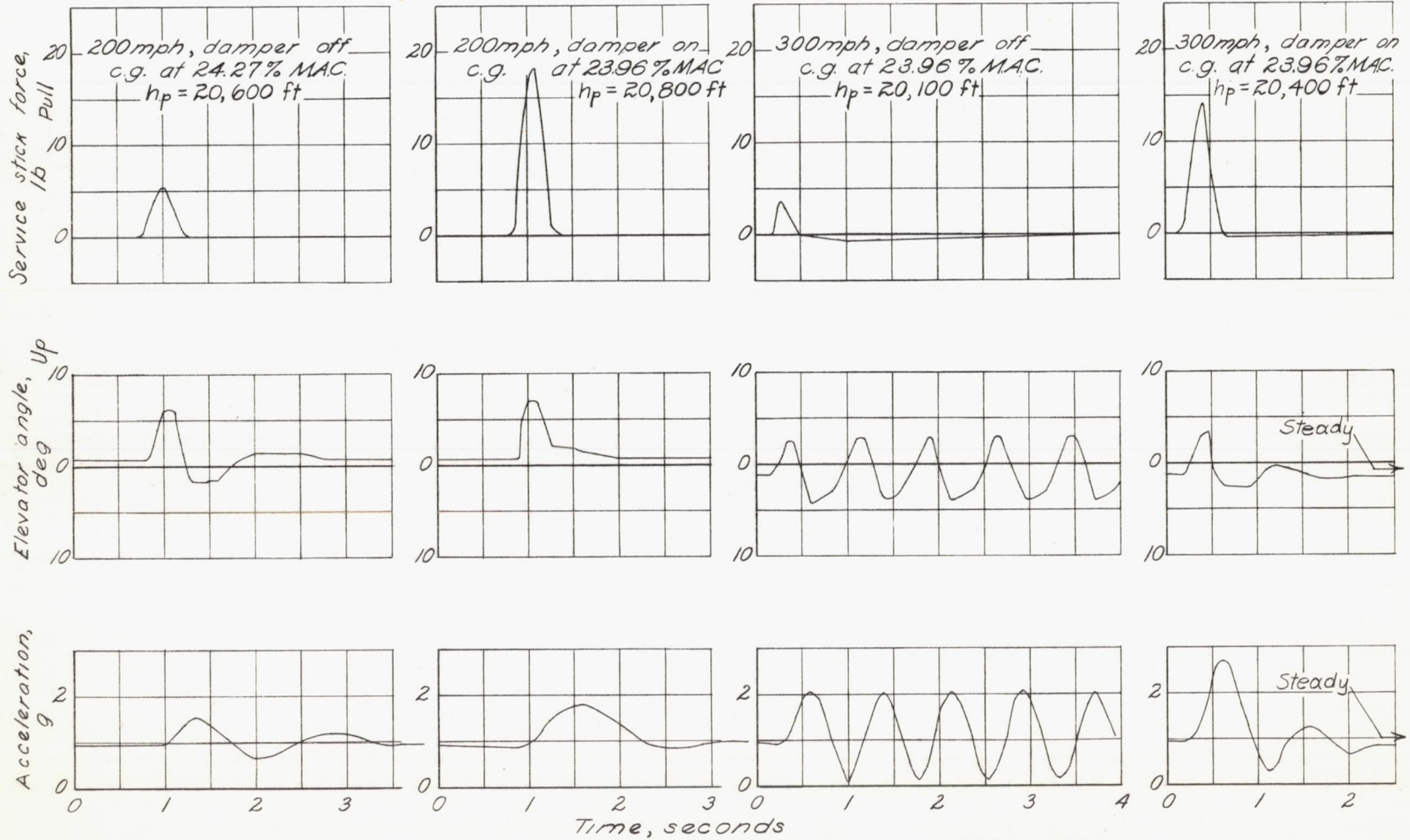

NATIONAL ADVISORY  
COMMITTEE FOR AERONAUTICS

(b) High altitude.  
Figure 20.- Concluded.

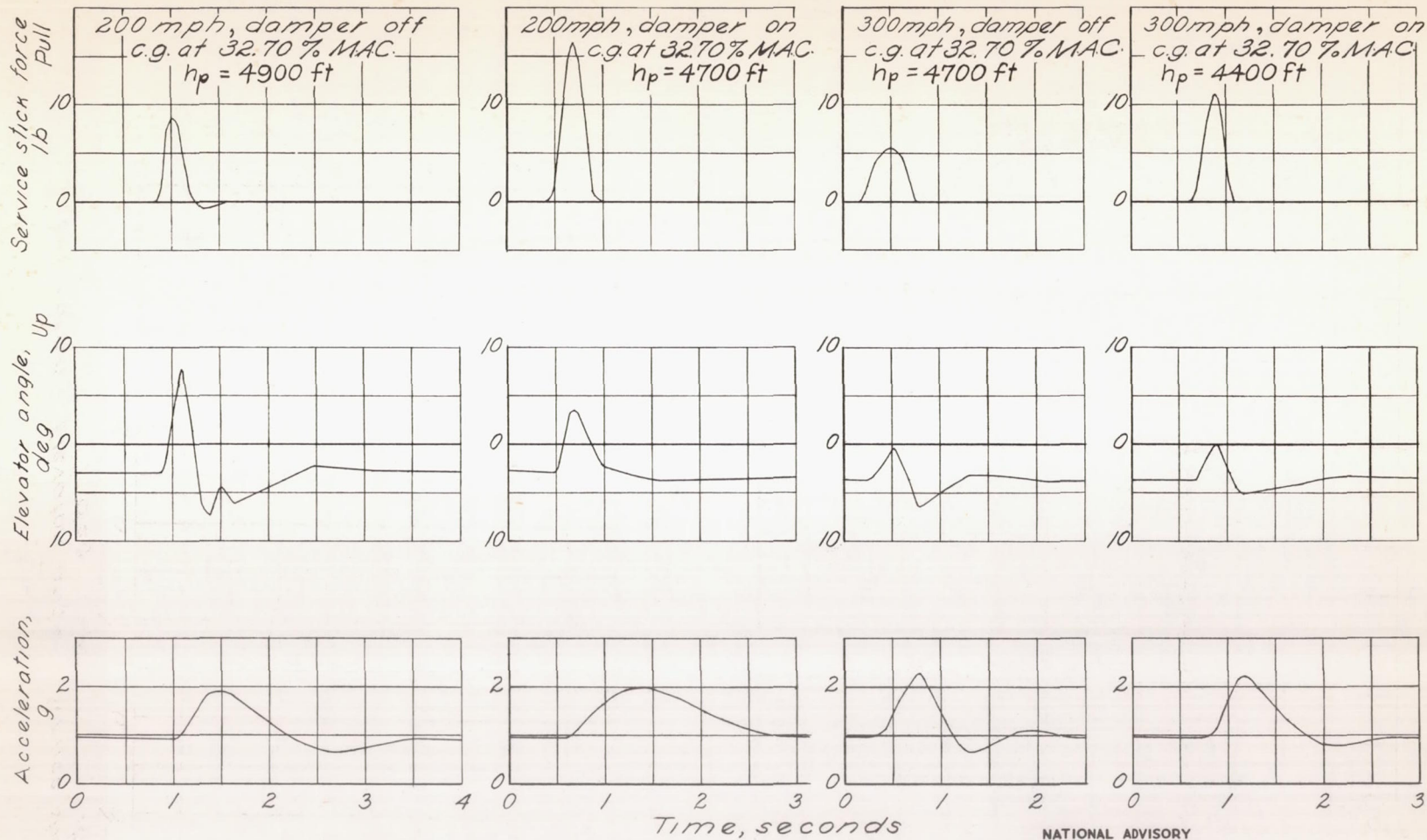

NATIONAL ADVISORY  
COMMITTEE FOR AERONAUTICS

(a) Low altitudes.

Figure 21.- Short-period oscillation characteristics with 3.7 pound bobweight for extreme rearward center-of-gravity positions. Control-feel device with orifice B.

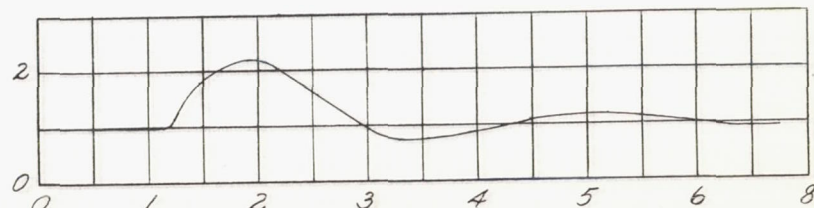
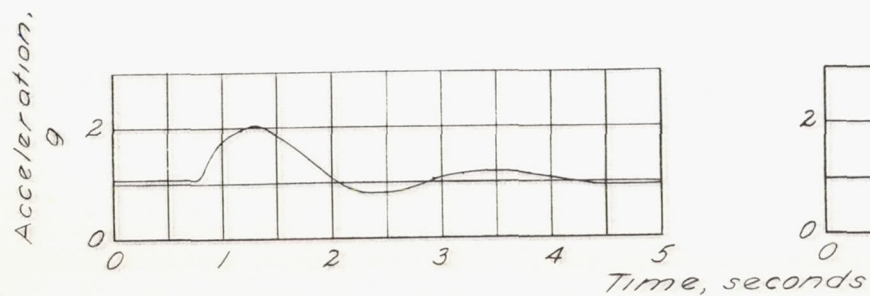
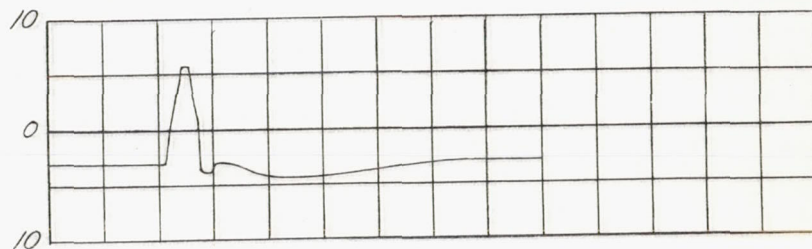
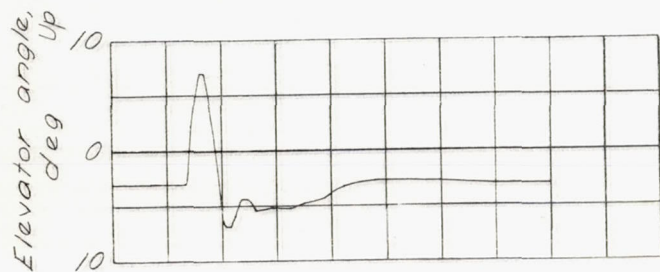
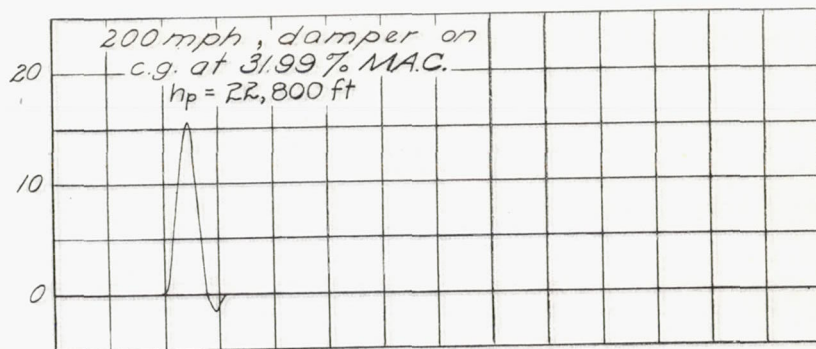
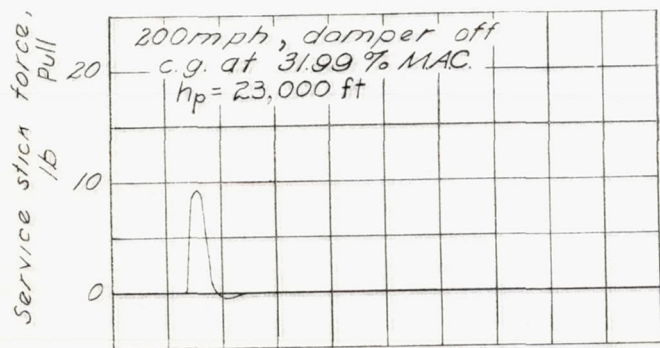

NATIONAL ADVISORY  
COMMITTEE FOR AERONAUTICS

(b) High altitude,  $V_c = 200$  mph.

Figure 21.- Continued.

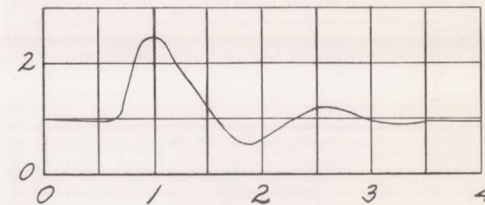
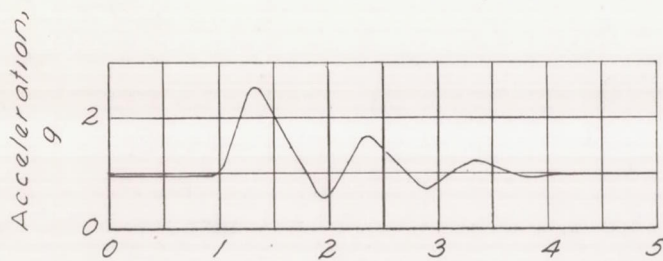
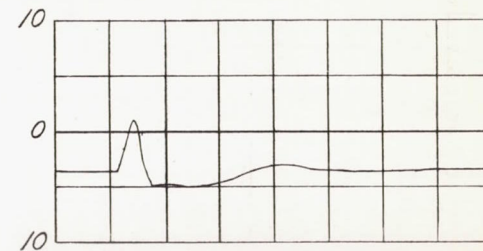
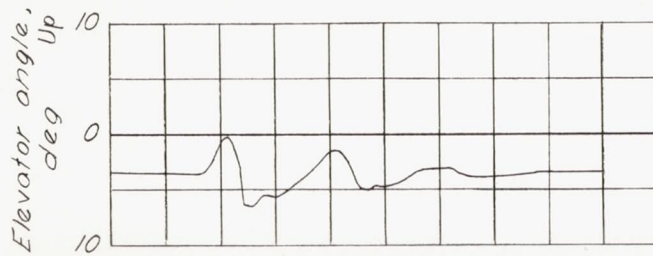
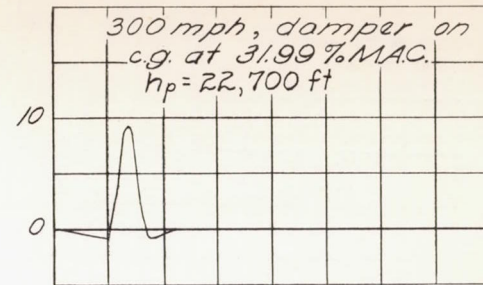
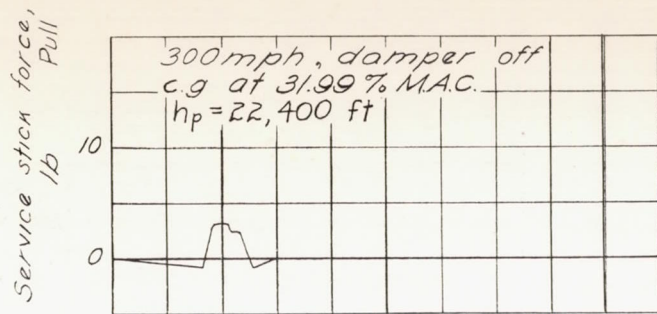

Time, seconds

NATIONAL ADVISORY  
COMMITTEE FOR AERONAUTICS

(c) High altitude,  $V_c = 300$  mph.

Figure 21.- Concluded.

MR No. L6E20

(a) Low altitudes,  $V_c = 200$  mph.

Figure 22.- Short-period oscillation characteristics with 3.7 pound bobweight and viscous friction in control system for forward center of gravity positions. Control-feel device with orifice B.



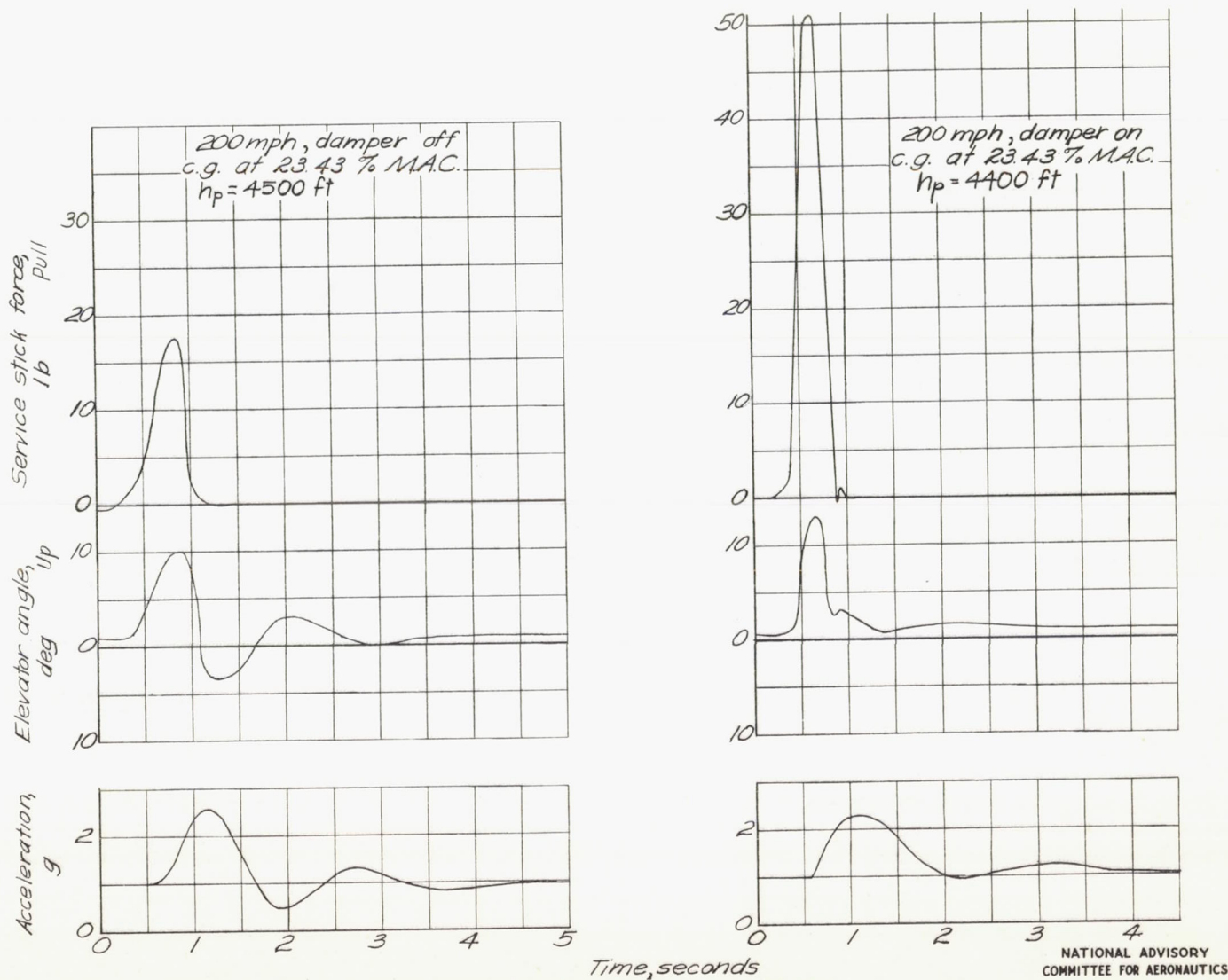
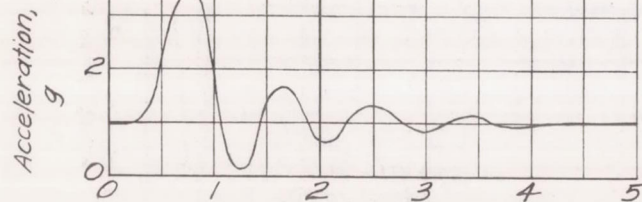
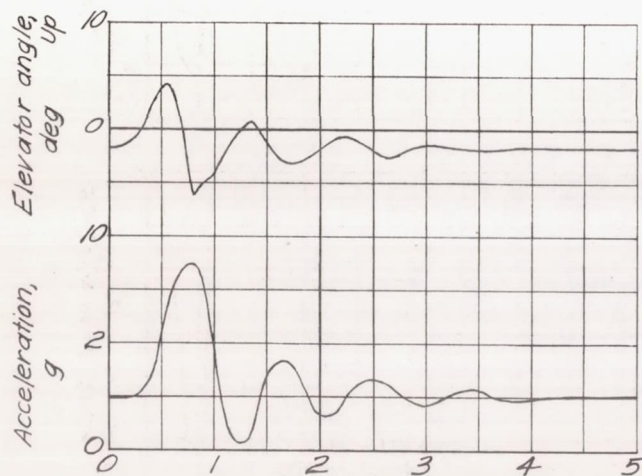
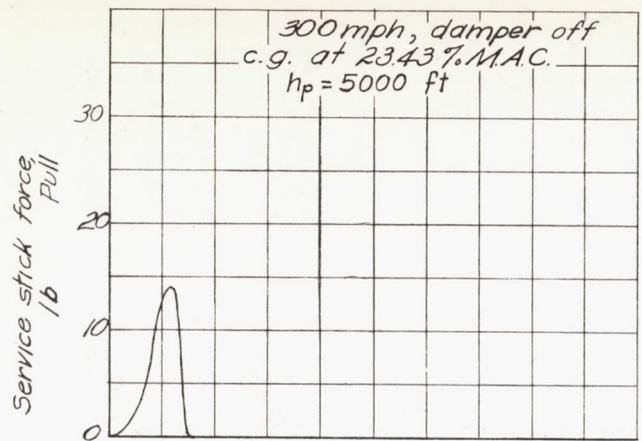

Time, seconds

(b) Low altitude,  $V_c = 300$  mph.

Figure 22.- Continued.

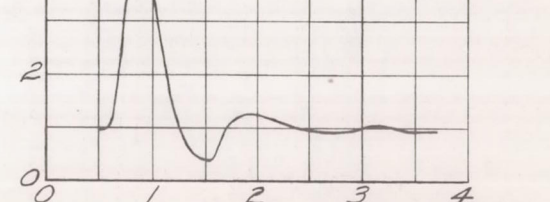
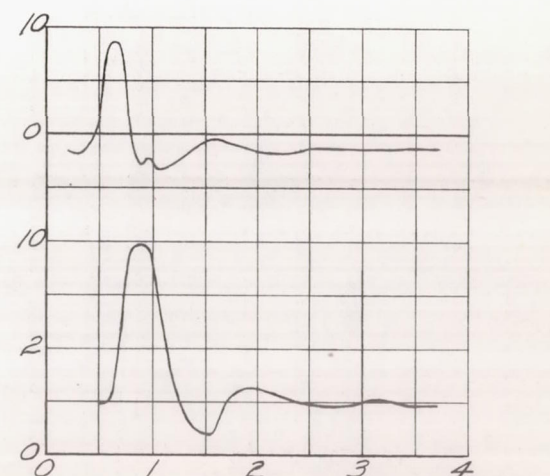
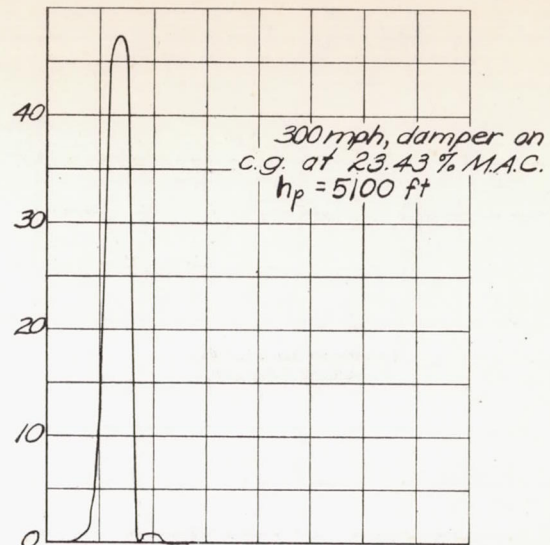

Time, seconds  
NATIONAL ADVISORY  
COMMITTEE FOR AERONAUTICS

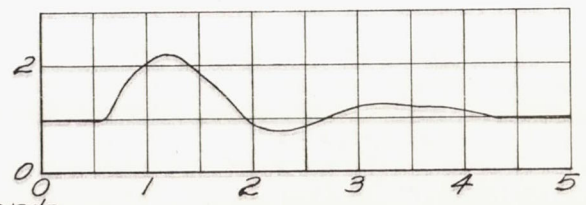
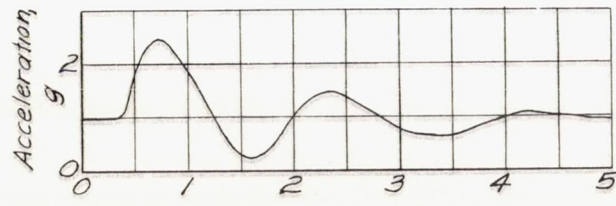
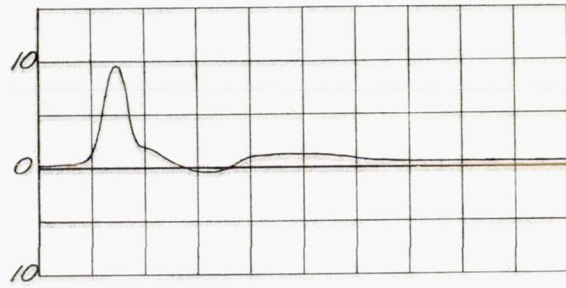
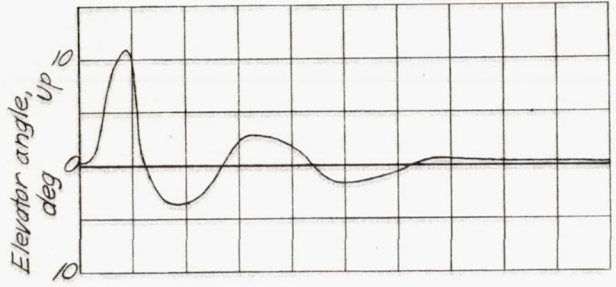
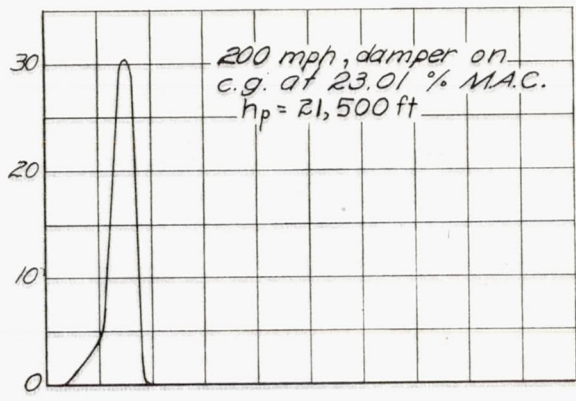
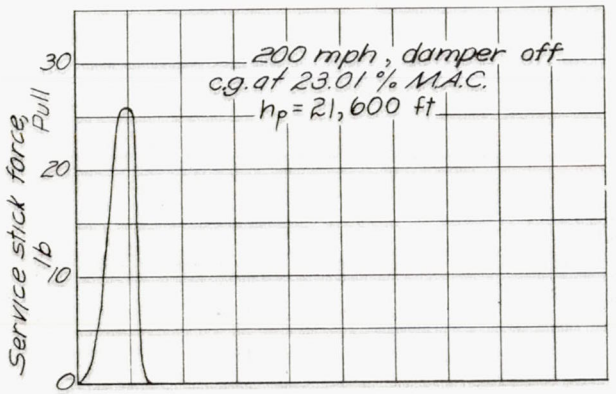

NATIONAL ADVISORY  
COMMITTEE FOR AERONAUTICS

Time, seconds

(c) High altitude,  $V_c = 200$  mph.  
Figure 22.- Continued.

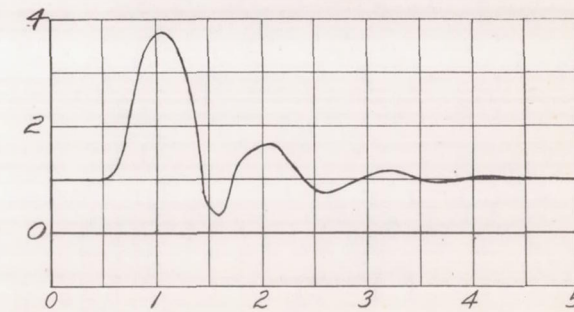
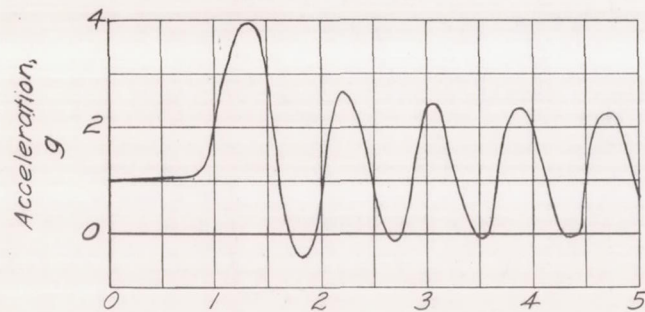
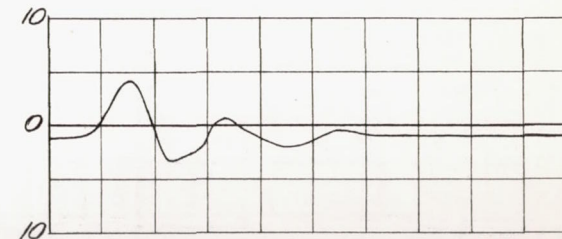
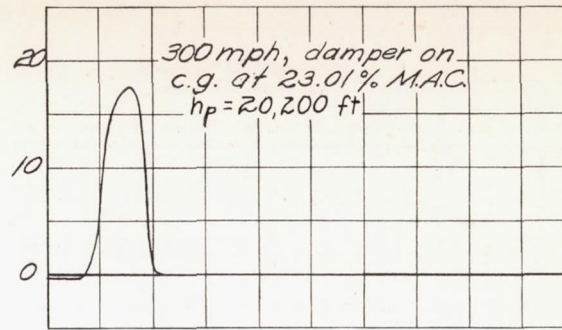
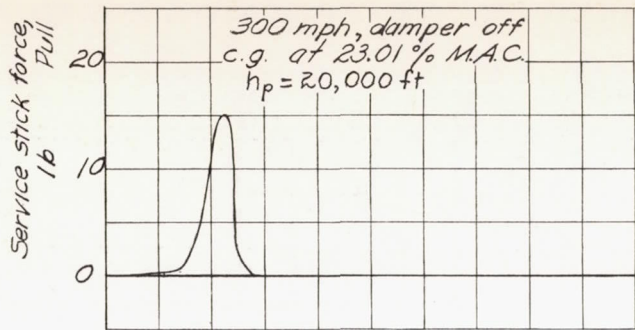

NATIONAL ADVISORY  
COMMITTEE FOR AERONAUTICS

(d) High altitude,  $V_c = 300$  mph.

Figure 22.- Concluded.

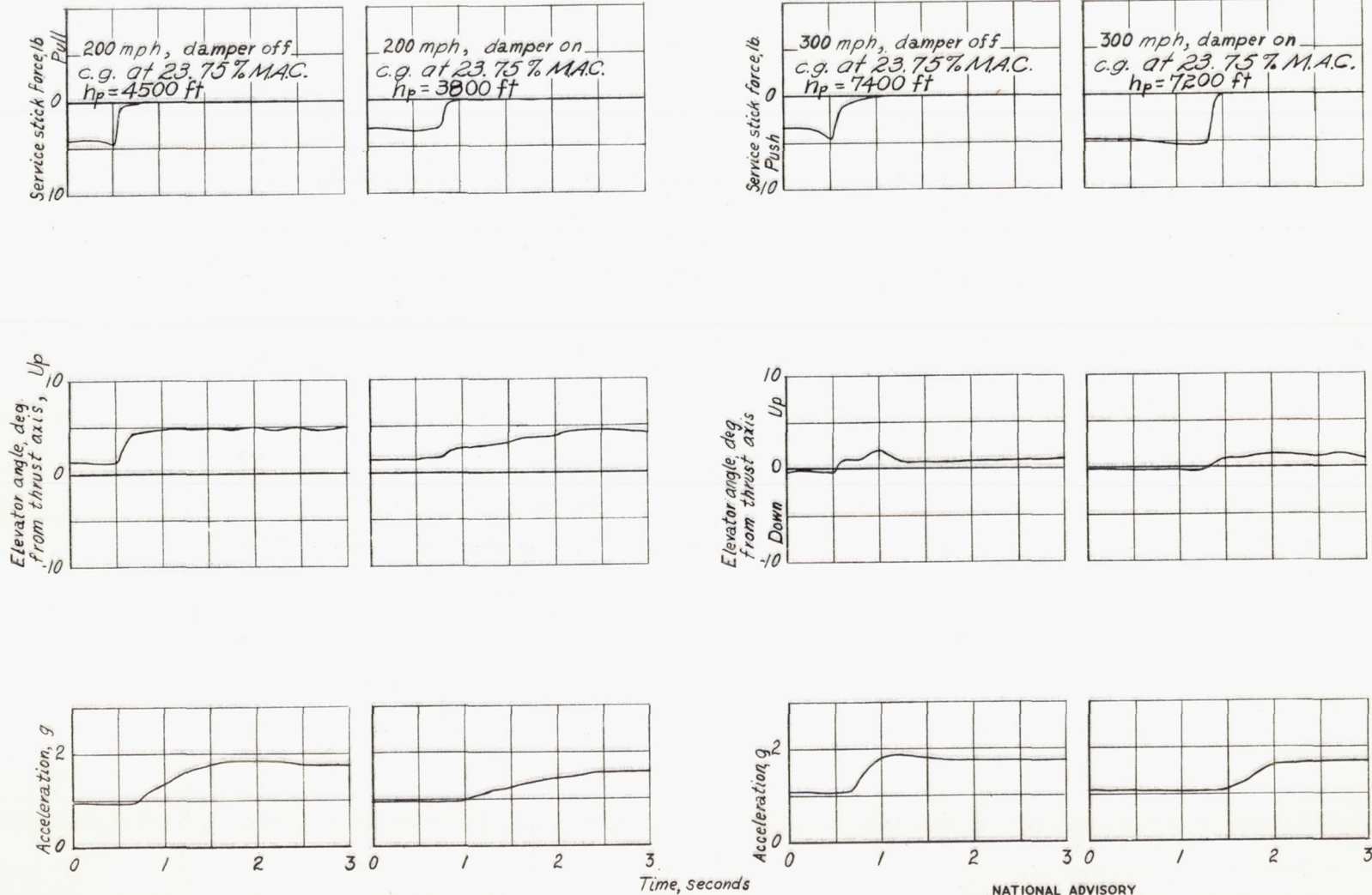

NATIONAL ADVISORY  
COMMITTEE FOR AERONAUTICS

Figure 23.- Stick-release pull-up characteristics without bobweight at low altitudes. Control-feel device with orifice A.

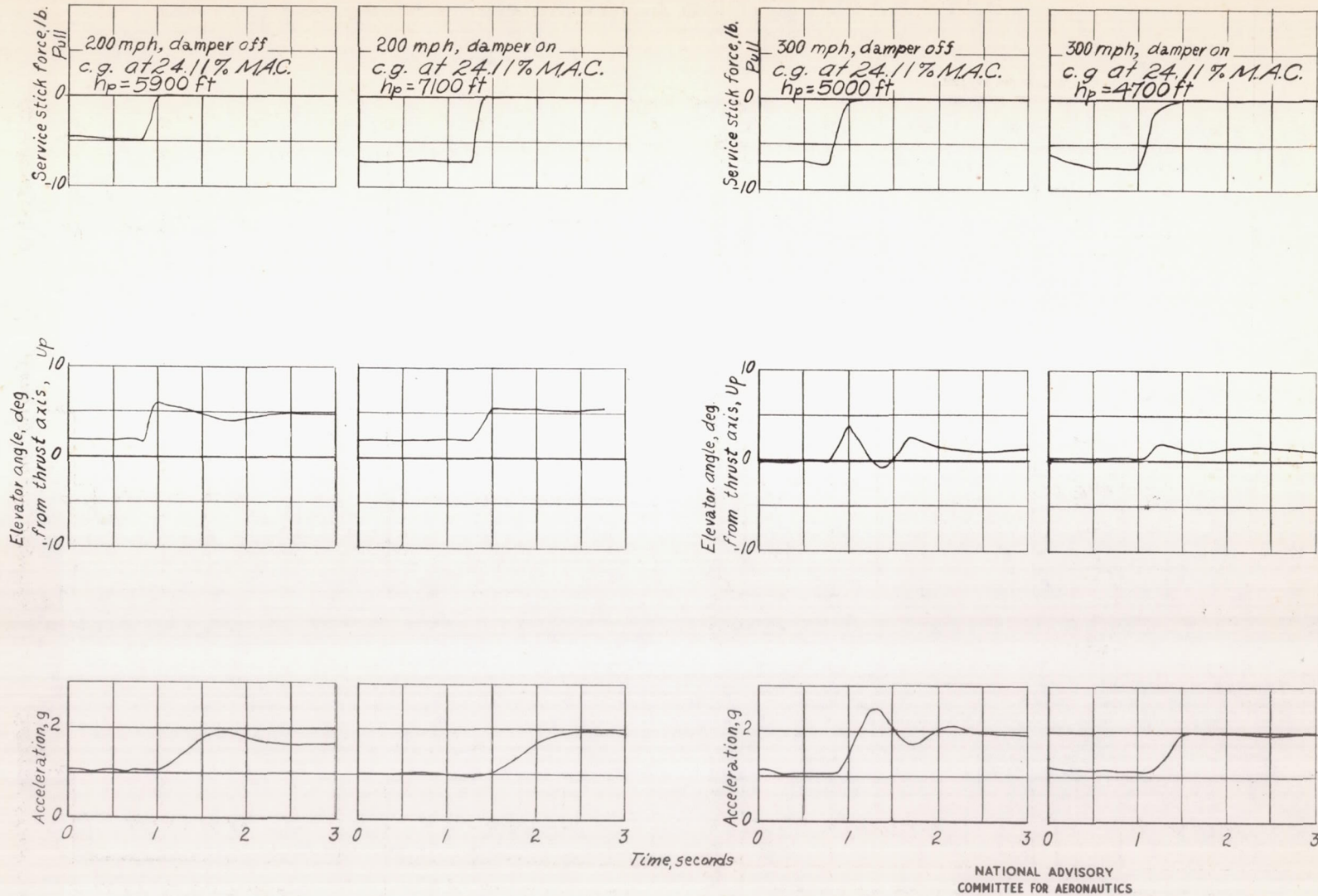
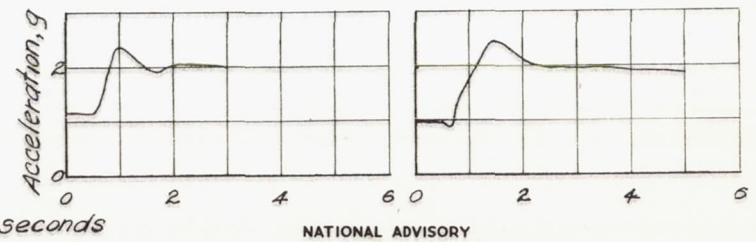
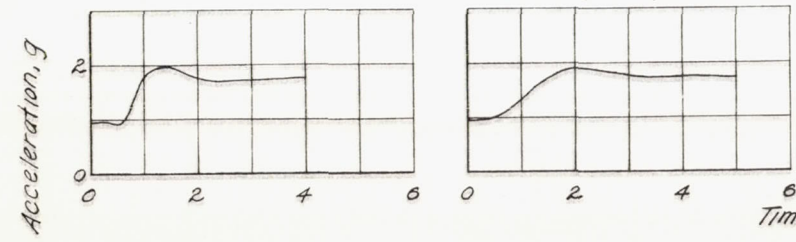
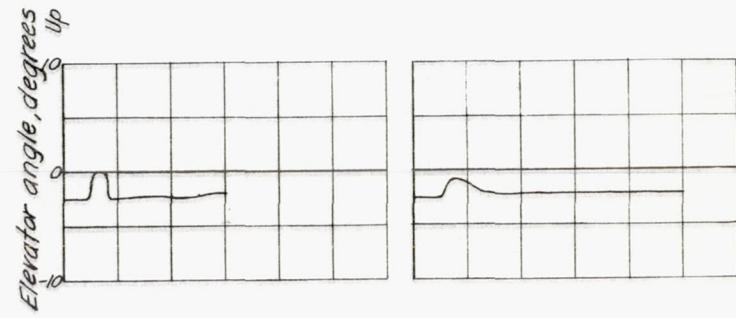
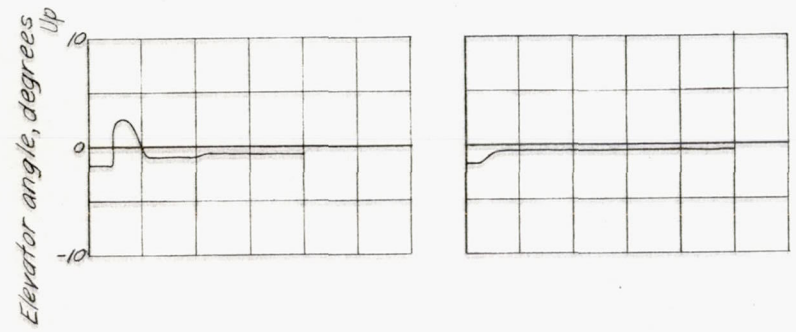
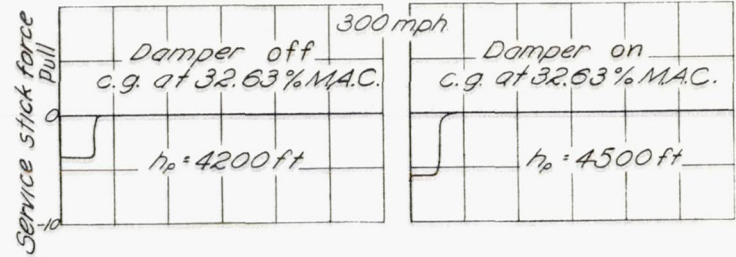
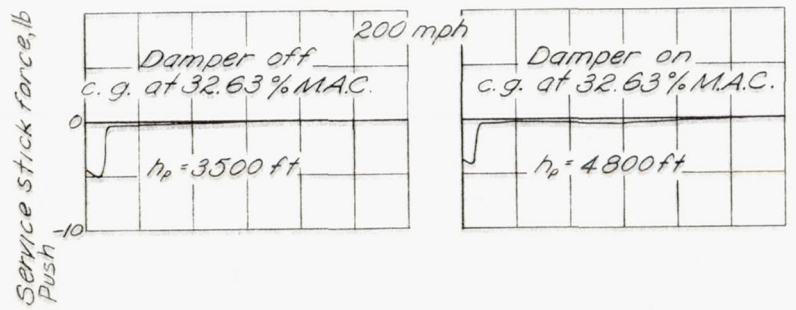
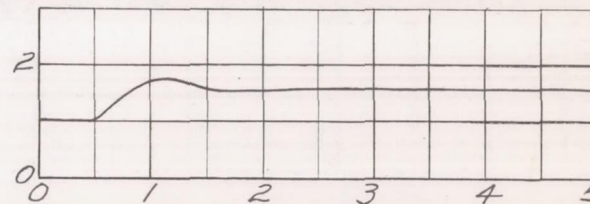
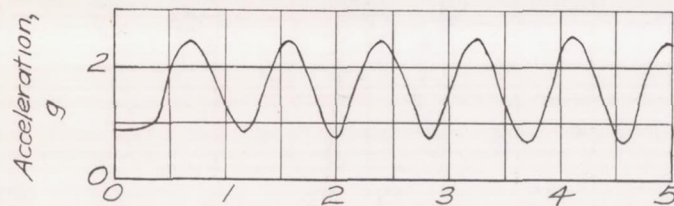
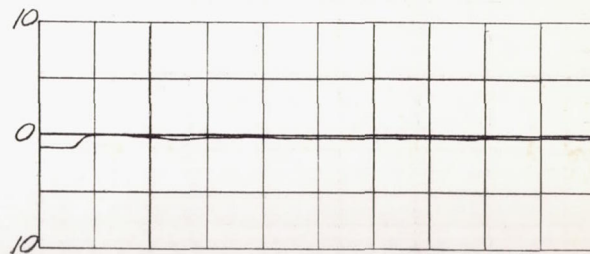
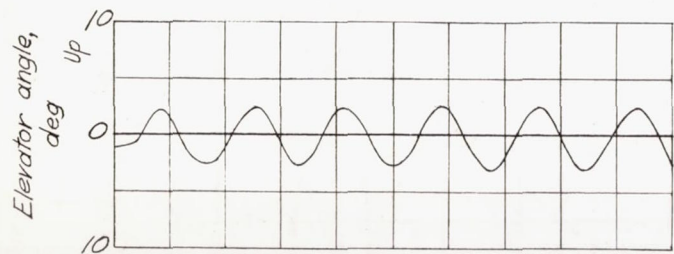
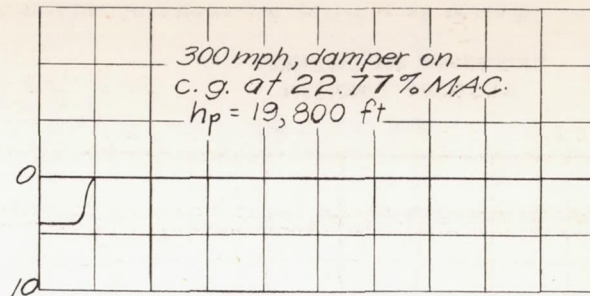
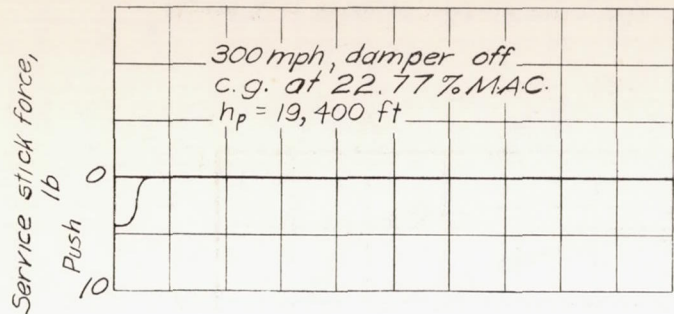

Figure 24.- Stick-release pull-up characteristics with 3.7 pound bobweight in elevator control system at low altitudes. Control-feel device with orifice A.



NATIONAL ADVISORY  
COMMITTEE FOR AERONAUTICS

Figure 25.- Stick-release pull-up characteristics with 3.7 pound bobweight in elevator control system at low altitudes for rearward center-of-gravity positions. Control-feel device with orifice B.



Time, seconds

NATIONAL ADVISORY  
COMMITTEE FOR AERONAUTICS

Figure 26.- Stick-release pull-up characteristics with 3.7 pound bobweight and viscous friction in elevator control system at high altitudes for forward center-of-gravity positions. Control-feel device with orifice B.

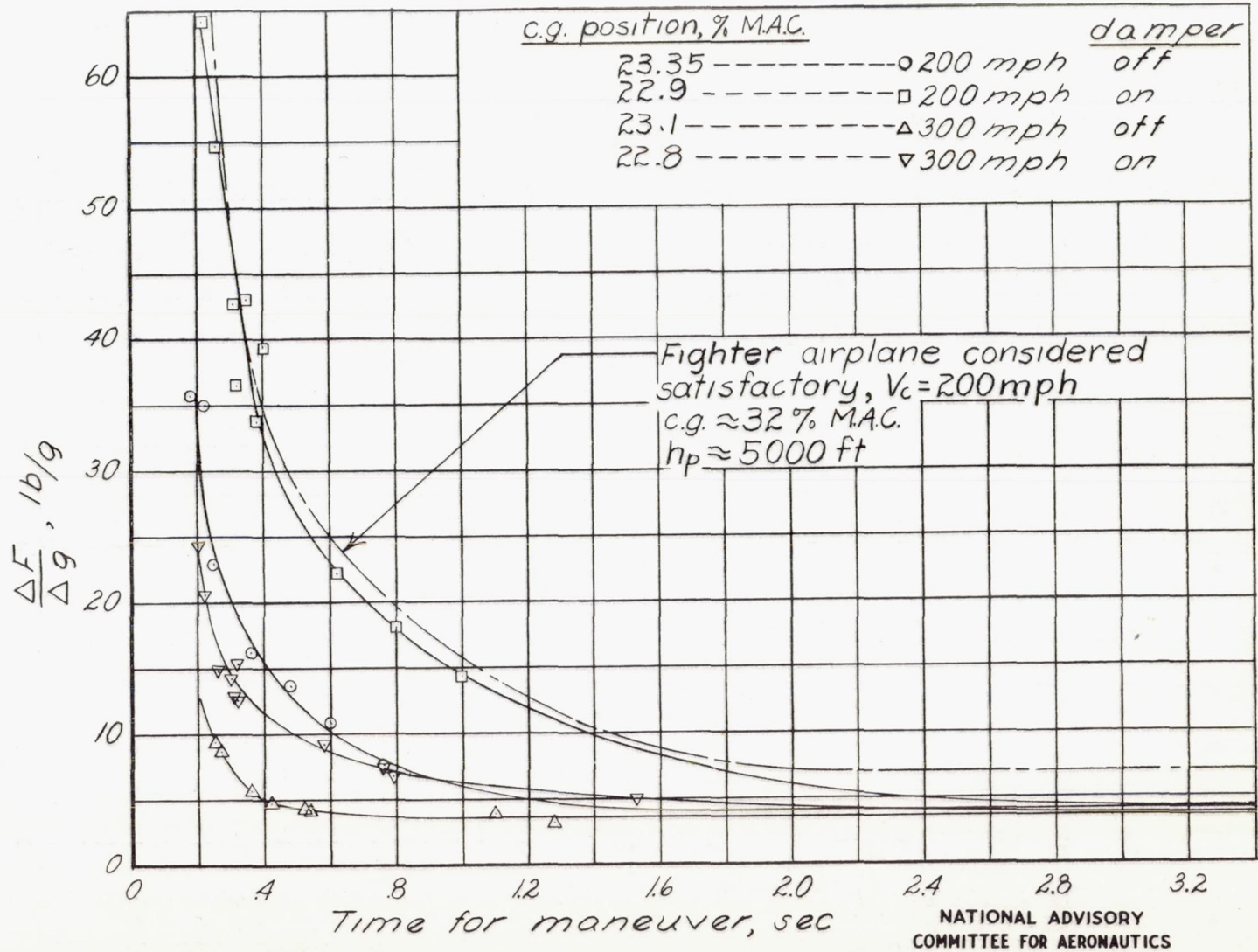

Figure 27.- Ratio of maximum stick force to maximum acceleration in controlled pull-ups at various rates at 5,000 feet altitude. Without bobweight, forward center of gravity positions. Control-feel device with orifice A.



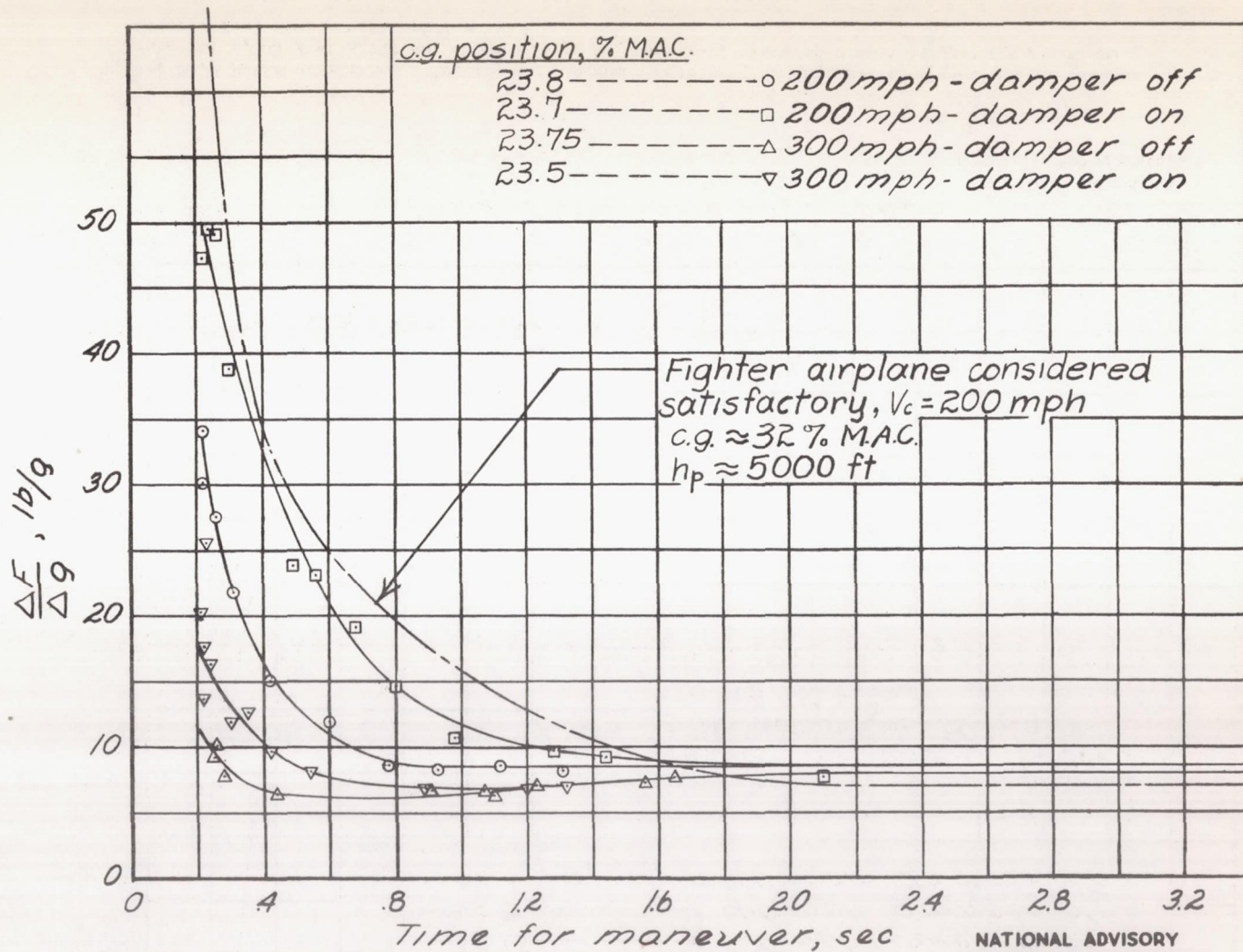

Figure 28.- Ratio of maximum stick force to maximum acceleration in controlled pull-ups at various rates at 5,000 feet altitude. With 3.7 pound bobweight, forward center of gravity positions. Control-feel device with orifice A.

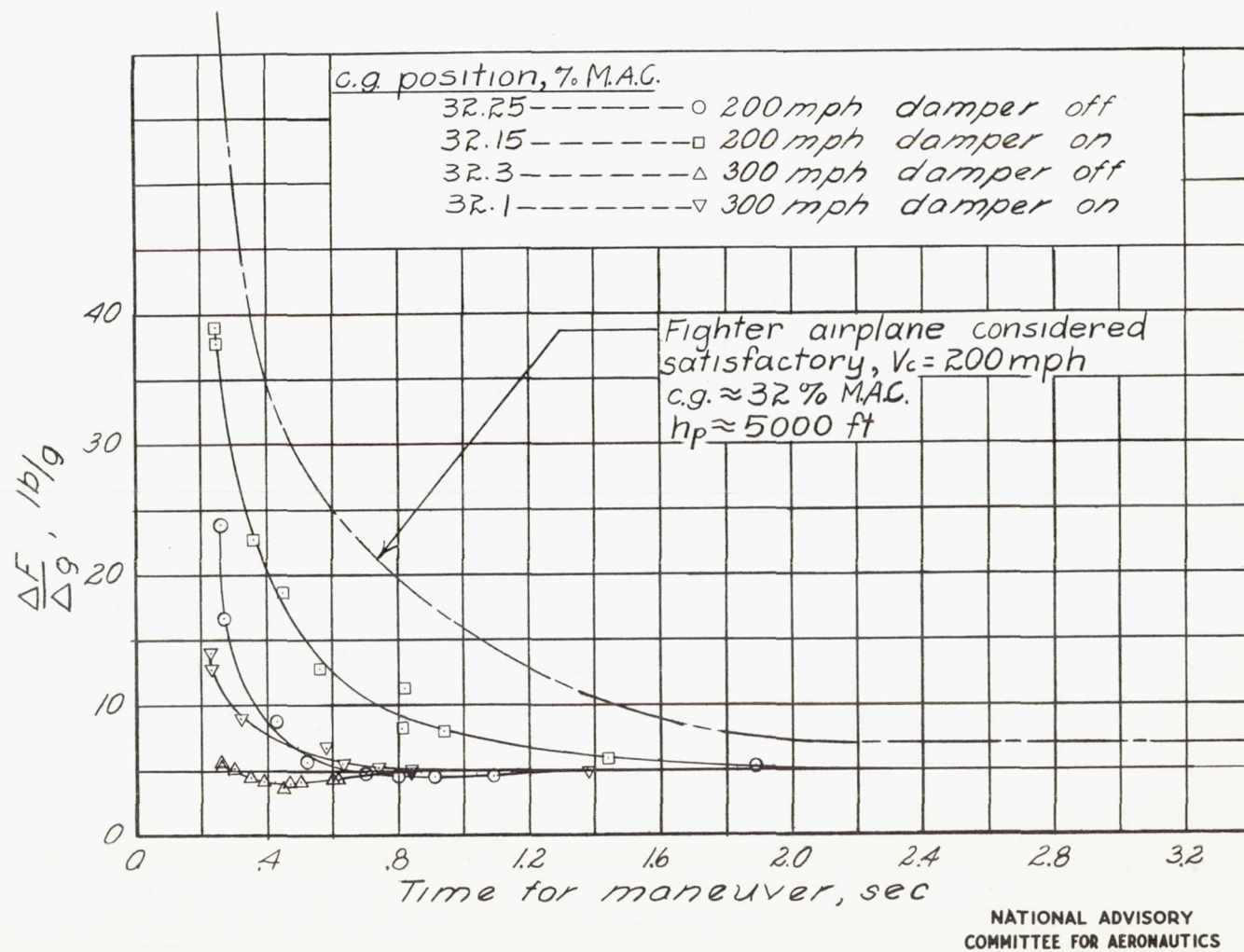
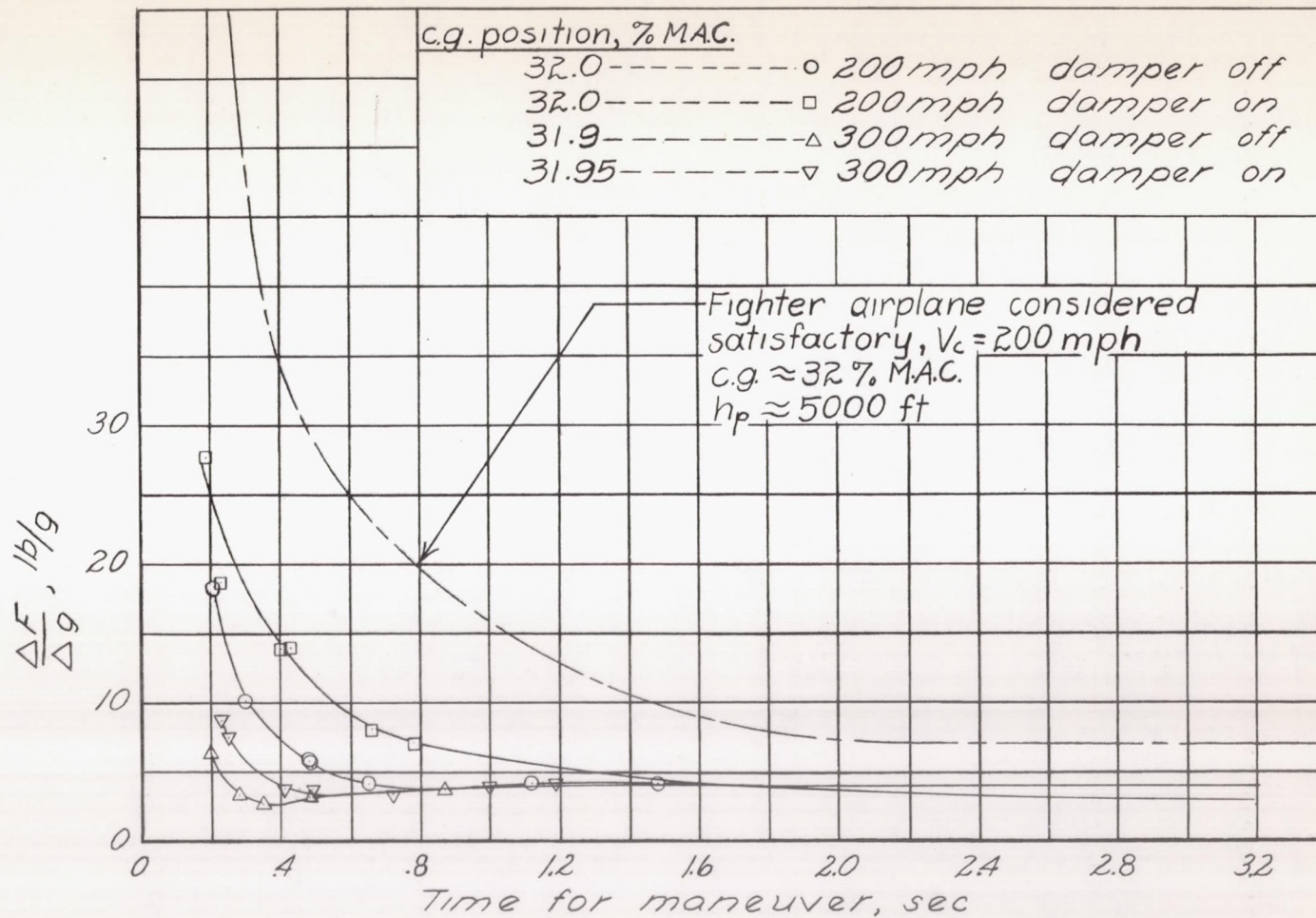

Figure 29.- Ratio of maximum stick force to maximum acceleration in controlled pull-ups at various rates at 5,000 feet altitude. With 3.7 pound bobweight, rearward center of gravity positions. Control-feel device with orifice B.



NATIONAL ADVISORY  
 COMMITTEE FOR AERONAUTICS

Figure 30.- Ratio of maximum stick force to maximum acceleration in controlled pull-ups at various rates at 22,000 feet altitude. With 3.7 pound bobweight, rearward center of gravity positions. Control-feel device with orifice B.