

NATIONAL ADVISORY COMMITTEE FOR AERONAUTICS

# WARTIME REPORT

ORIGINALLY ISSUED

January 1946 as  
Memorandum Report E6A23

LABORATORY INVESTIGATION OF ICING IN THE CARBURETOR AND

SUPERCHARGER INLET ELBOW OF AN AIRCRAFT ENGINE

VI - EFFECT OF MODIFICATIONS TO FUEL-SPRAY

NOZZLE ON ICING CHARACTERISTICS

By Donald R. Mulholland and Gilbert E. Chapman

Aircraft Engine Research Laboratory  
Cleveland, Ohio

**FILE COPY**

To be returned to  
the files of the National  
Advisory Committee  
for Aeronautics  
Washington, D. C.



WASHINGTON

NACA WARTIME REPORTS are reprints of papers originally issued to provide rapid distribution of advance research results to an authorized group requiring them for the war effort. They were previously held under a security status but are now unclassified. Some of these reports were not technically edited. All have been reproduced without change in order to expedite general distribution.

NACA AIRCRAFT ENGINE RESEARCH LABORATORY

MEMORANDUM REPORT

for the

Air Technical Service Command, Army Air Forces

LABORATORY INVESTIGATION OF ICING IN THE

CARBURETOR AND SUPERCHARGER INLET ELBOW

OF AN AIRCRAFT ENGINE

VI - EFFECT OF MODIFICATIONS TO FUEL-SPRAY

NOZZLE ON ICING CHARACTERISTICS

By Donald R. Mulholland and Gilbert E. Chapman

SUMMARY

In order to prevent the formation of refrigeration icing in the induction system of an aircraft engine, several modifications to the spray nozzle were designed and tested. The modifications varied from a revised pintle to actual changes in the point of fuel injection without a basic alteration of the standard spray nozzle. Prevention of refrigeration icing in the carburetor and inlet elbow was achieved when the fuel spray was completely removed from the inlet-elbow passage and injected directly into the supercharger inlet through orifices in or attached to the rotating impeller. Two fuel-injection systems, a spinner type and a drilled-inducer type, that satisfactorily prevent the formation of refrigeration icing in the induction system were developed.

INTRODUCTION

At the request of the Air Technical Service Command, Army Air Forces, extensive icing and de-icing tests (references 1, 2, 3, and 4) were made during 1944 at the NACA Cleveland laboratory on a twin-barrel injection carburetor and engine-stage supercharger assembly used on a fighter airplane. The results of these tests indicated that most of the serious icing, which occurred on the carburetor throttle plates and in the supercharger inlet elbow, was of the refrigeration type caused by the cooling effect of the evaporation of fuel introduced into the air stream.

Serious refrigeration icing, particularly at low-power conditions, occurred for such a wide range of inlet-air conditions that research was undertaken to devise a simple modification to the fuel-injection system, which might prevent this type of icing. Several modifications were developed, none of which altered the basic design of the fuel nozzle. It was hoped that a simple design such as a straight tube might carry the fuel spray across the supercharger inlet passage to the impeller entrance and prevent the recirculatory action that allowed time for the fuel to vaporize and cool the metal parts upstream.

One method of injecting fuel from rotating orifices at the entrance to the supercharger has been shown (PWA-342, Jan. - Oct. 1941) to be effective in preventing refrigeration icing. Reference 5 reports another method of injecting fuel through holes drilled in the impeller of a double-row radial aircraft engine, which improved engine cooling through better fuel distribution, and also anticipates the elimination of refrigeration icing.

The purpose of the investigation reported herein was the development of a simple method of preventing fuel recirculation and consequent refrigeration icing.

#### APPARATUS AND TESTS

The apparatus used to conduct tests of the fuel-spray modifications consisted of the twin-barrel injection carburetor and engine-stage supercharger assemble, which is described in detail in reference 6. This apparatus was designed and operated to maintain accurate control of fuel and water temperatures, and flow rate, temperature, humidity, and free-water content of charge air. The carburetor was equipped with a special mixture-control plate, which permitted the fuel-air ratio to be adjusted to any desired value.

The standard fuel-injection nozzle was used in all the tests reported in reference 1 and produced the fuel spray shown in figure 1(a). A fuel spray from a modified nozzle is shown in figure 1(b).

The modifications to the fuel-spray nozzle were developed with the intention of minimizing fuel recirculation in the supercharger inlet elbow and the lower throttle barrels. The modifications progressed from a simple change in the shape of the pintle head (fig. 1(b)) through more complicated modifications including changes in the location of the nozzle (figs. 2(a) and 2(b)), the use of straight tubes to convey the fuel across the inlet elbow to the face

of the impeller (figs. 2(c) to 2(e)), the use of protective hoods to direct the fuel spray into the impeller (figs. 2(f) to 2(j)), and the final modifications incorporating a fuel spinner located on the impeller shaft (figs. 2(k) to 2(p)).

The details of the spinner-type fuel-injection unit (fig. 2(n)) are shown in figure 3. In this system, fuel passes through the standard fuel nozzle, the pintle of which has been cropped, and then through the fuel-transfer tube and spinner. The fuel is discharged directly from the spinner between each of the impeller vanes at the face of the impeller.

The details of the drilled-inducer fuel-injection system (fig. 2(p)) are shown in figure 4. These parts are similar to those used in the spinner-type system; however, the spinner is smaller in diameter and fits directly on the impeller shaft. The outlets of the spinner communicate with drilled passages in the inducer portion of the supercharger impeller, allowing the fuel to be discharged between the blades approximately thirteen-sixteenths inch in from the impeller face.

Each of the fuel-injection modifications was tested for a minimum period of 15 minutes, during which time conditions conducive to very serious refrigeration icing were simulated. The more successful fuel-injection systems were extensively tested under a variety of conditions consisting mainly in variations in air temperature, free-water content, and throttle angle (power condition). Observations of the results were made through plastic windows installed in each side of the supercharger inlet elbow.

#### DISCUSSION

Close observation of the fuel spray through plastic windows in the supercharger inlet elbow during operation with the standard fuel-spray nozzle showed a recirculation of part of the fuel up to the carburetor throttle plates. The observed configuration of the fuel spray for each of three power conditions is shown in figure 5. Especially in the case of a simulated low-power condition during which the throttles are nearly closed, the recirculatory effect, together with splashing from the impeller, caused some of the fuel to pass near the throttles. The evaporative cooling action of the fuel not only reduced the temperature of the metal surfaces but also sufficiently cooled the air together with the entrained moisture to bring about condensation and subsequent ice formations on and near the throttles. In the case of high-power operation, the wide throttle opening improved the air flow, minimized fuel recirculation, and reduced icing.

Attempts to minimize fuel recirculation sufficiently to prevent refrigeration icing merely by removing part of the pintle head (fig. 1(b)) to direct the spray further below the throttles or by dropping the standard nozzle vertically to the impeller center line (fig. 2(a)) were unsuccessful; the next group of modifications therefore consisted in moving the fuel outlet across the inlet-elbow passage closer to the face of the impeller. By the use of an extended nozzle and straight tubes (figs. 2(b) to 2(e)) to convey the fuel to the face of the impeller, much of the icing was prevented but not eliminated. Metal hoods over the spray to prevent recirculation (figs. 2(f) to 2(j)) were found in every case to be sufficiently cooled to collect large amounts of ice. It became apparent that evaporation of the fuel in the inlet elbow should be prevented if icing were to be avoided.

Further modifications consisted in attaching revolving distributors to the impeller hub to spray fuel directly into the impeller entrance in order to avoid splashing and recirculation. The first rotating device tested (fig. 2(k)) was a simple slinger ring, which was found to be so shallow and open that it allowed spillage and splash causing icing in the elbow. Subsequent modifications (figs. 2(l) to 2(p)) were made with large tapered inner cavities to receive the fuel and, in addition, internal threads were provided at the spinner entrances to prevent return flow of fuel.

Both the spinner-type and the drilled-inducer fuel-injection systems prevent serious refrigeration icing in the carburetor because no fuel recirculation can take place and a large part of the fuel evaporation occurs within the supercharger where the heating brought about by adiabatic compression prevents ice formation. If the incoming carburetor-air temperature is sufficiently low to prevent a rise in temperature above  $32^{\circ}\text{F}$  in the supercharger impeller, it is known that the total water content in the atmosphere then would not be high enough to permit appreciable icing.

In order to determine the actual fuel path within the impeller and the amount of splashback from the impeller blades, high-speed photographs of the rotating members were taken during operation with the carburetor removed. These photographs, for which the exposure time was approximately  $1\frac{1}{2}$  microseconds, are shown in figures 6 and 7.

Water was used in place of fuel to insure safe exposed operation. Various rates of liquid flow corresponding to the fuel flows at several power conditions were used to check the capacity of the injection spinners and to insure that the restrictions caused by the tubes would not upset the carburetor metering at maximum flow.

Though negligible splashback occurred with either the spinner-type fuel injection or the drilled-inducer fuel injection, it can be seen by a comparison of figures 6(a) and 6(b) with 7(a) and 7(b), respectively, that, as the point of fuel injection is moved farther into the impeller, the possibility of splashback from the impeller blades is reduced to a minimum.

The spinner used for spinner injection in the maximum and minimum angular positions relative to the impeller blades is shown in figure 6(c). The fuel-spray paths in these photographs indicate the allowable tolerance of installation in order that the fuel outlets will not be blocked by the blade roots.

Because the carburetor was equipped with a special mixture control plate, which allowed the fuel-air ratio to be adjusted to any desired value, and because no measurements were made at the fuel discharge pressure, it is not known to what extent the metering characteristics of a standard carburetor would have been affected by the rotating injection nozzles. Satisfactory metering was obtained with no increase in the specified fuel pressure at the carburetor inlet.

Further tests using the two types of spinner fuel injection have been made, both on laboratory test stands and in flight, to determine the full-scale engine operating characteristics.

#### SUMMARY OF RESULTS

From an investigation of various modifications to the fuel-spray nozzle in a supercharger inlet elbow used with an injection-type carburetor, the following results were obtained:

1. The occurrence of serious refrigeration icing in the carburetor and the supercharger inlet elbow was prevented by completely removing the fuel spray from the inlet-elbow passage and injecting the fuel directly into the supercharger inlet from a discharge source rotating at supercharger-impeller speed.
2. The transfer of the point of fuel injection was accomplished without altering the basic design of the standard fuel-spray nozzle. The metering characteristics of the carburetor appeared to be unaffected by the rotating fuel-injection systems.

3. The spinner-type fuel-injection system and the drilled-inducer fuel-injection system both satisfactorily prevented the occurrence of refrigeration icing in the carburetor and in the supercharger inlet elbow.

Aircraft Engine Research Laboratory,  
National Advisory Committee for Aeronautics,  
Cleveland, Ohio.

#### REFERENCES

1. Essex, Henry A., Keith, Wayne C., and Mulholland, Donald R.: Laboratory Investigation of Icing in the Carburetor and Supercharger Inlet Elbow of an Aircraft Engine. II - Determination of Limiting-Icing Conditions. NACA MR No. E5K18a, 1945.
2. Lyons, Richard E., and Coles, Willard D.: Laboratory Investigation of Icing in the Carburetor and Supercharger Inlet Elbow of an Aircraft Engine. III - Heated Air as a Means of De-Icing the Carburetor and Supercharger Inlet Elbow. NACA MR No. E5L19, 1945.
3. Chapman, G. E. and Zlotowski, E. D.: Laboratory Investigation of Icing in the Carburetor and Supercharger Inlet Elbow of an Aircraft Engine. IV - Effect of Throttle Design and Method of Throttle Operation on Induction-System Icing Characteristics. NACA MR No. E5L27, 1946.
4. Renner, Clark E.: Laboratory Investigation of Icing in the Carburetor and Supercharger Inlet Elbow of an Aircraft Engine. V - Effect of Injection of Water-Fuel Mixtures and Water-Ethanol - Fuel Mixtures on the Icing Characteristics. NACA MR No. E5L28, 1945.
5. Marble, Frank E., Ritter, William K., and Miller, Mahlon A.: Effect of the NACA Injection Impeller on the Mixture Distribution of a Double-Row Radial Aircraft Engine. NACA TN No. 1069, 1946.
6. Mulholland, Donald R., Rollin, Vern G., and Galvin, Herman B.: Laboratory Investigation of Icing in the Carburetor and Supercharger Inlet Elbow of an Aircraft Engine. I - Description of Setup and Testing Technique. NACA MR No. E5L13, 1945.

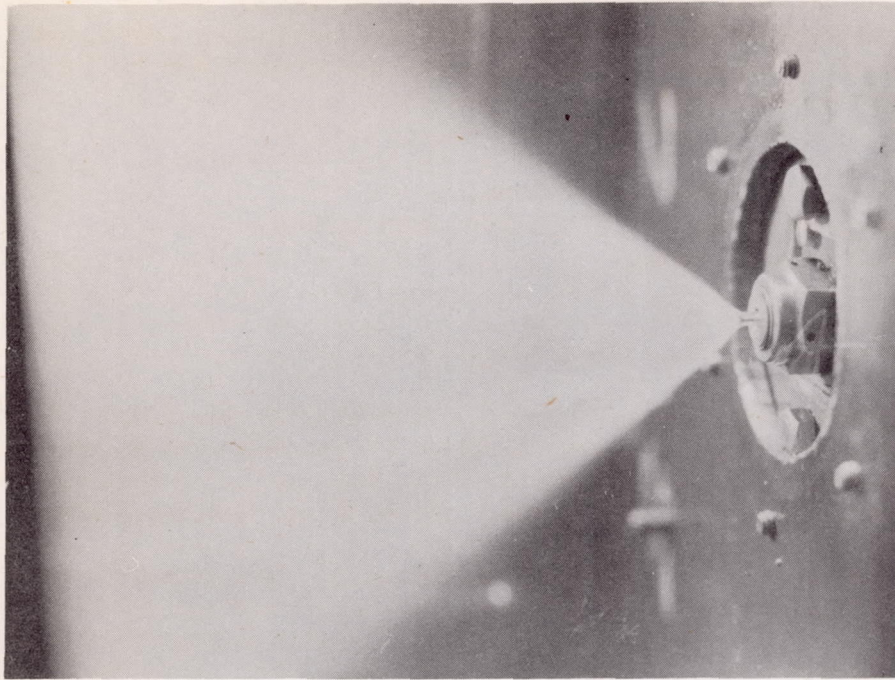

(a) Conventional injection nozzle.

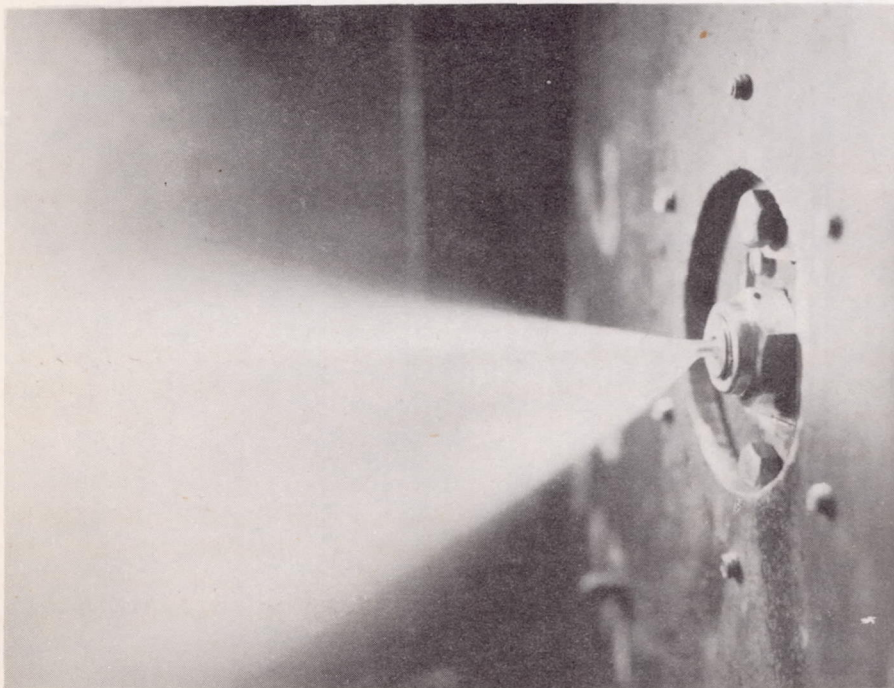

(b) Filed pintle head.

Figure 1. - Fuel sprays from conventional and modified nozzles. Fuel flow, 370 pounds per hour. Still air.

NACA  
C-14030  
1-14-46

E-175

59



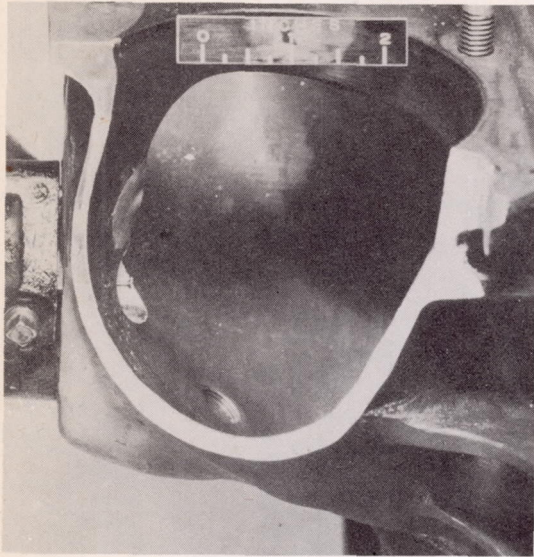

(a) Conventional nozzle lowered to center line of impeller.

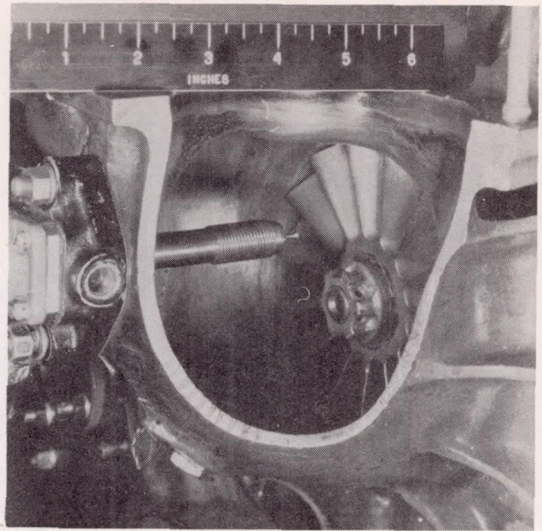

(b) Long nozzle extended toward the impeller from the regular position.

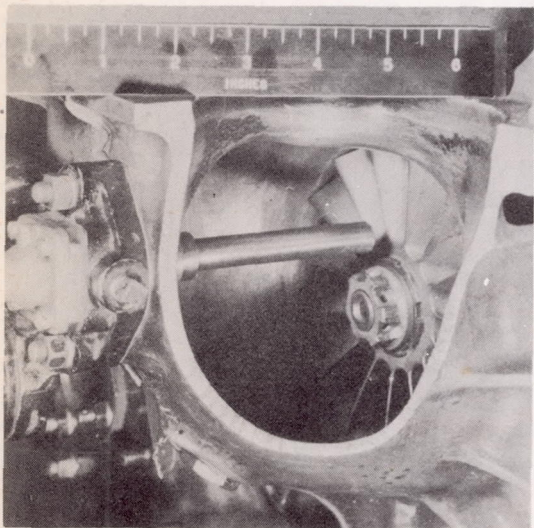

(c) A straight tube extending from the conventional nozzle.

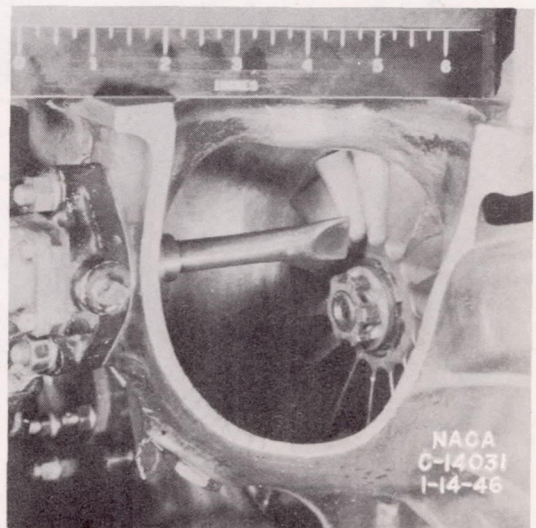

(d) A straight tube extending from the conventional nozzle but flattened on the exit end.

Figure 2. - Fuel-nozzle modifications.

E-175

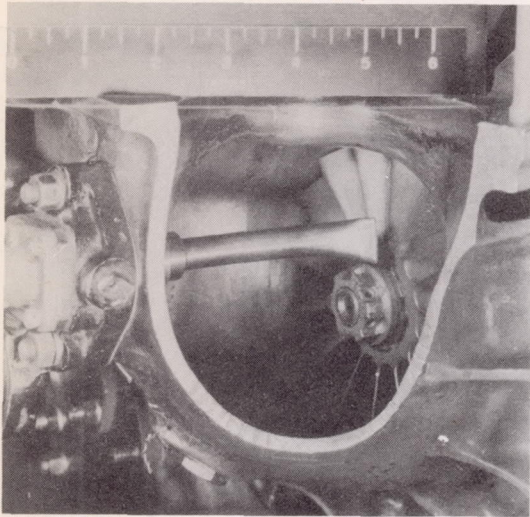

(e) A straight tube extending from the conventional nozzle, flattened on the exit end, and bent approximately  $45^\circ$ .

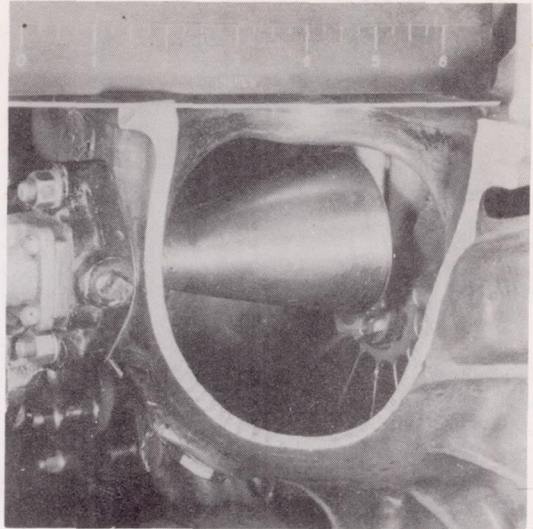

(f) The conventional type nozzle with a new pintle stem incorporating a smaller included angle on the pintle head and using a  $360^\circ$  protective hood.

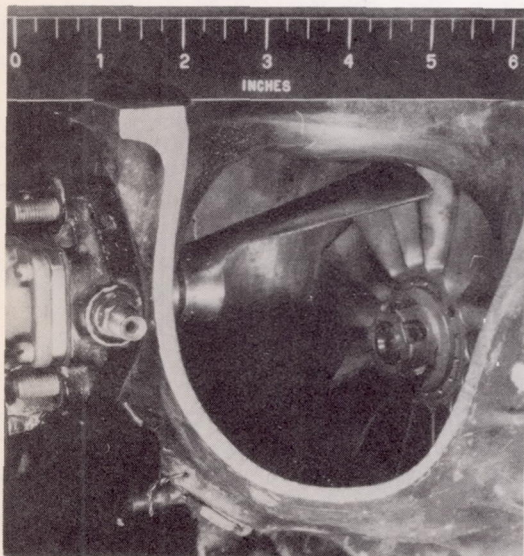

(g) Conventional nozzle with the revised pintle as in figure 1(b) using a  $15^\circ$  hood.

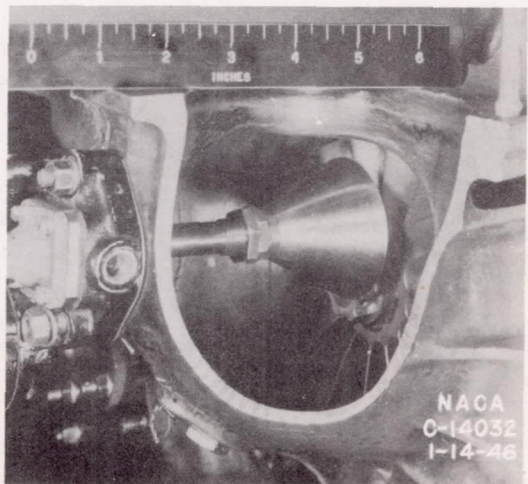

(h) Long nozzle extended to the impeller from the regular position using a  $360^\circ$  hood.

Figure 2. - Continued. Fuel-nozzle modifications.

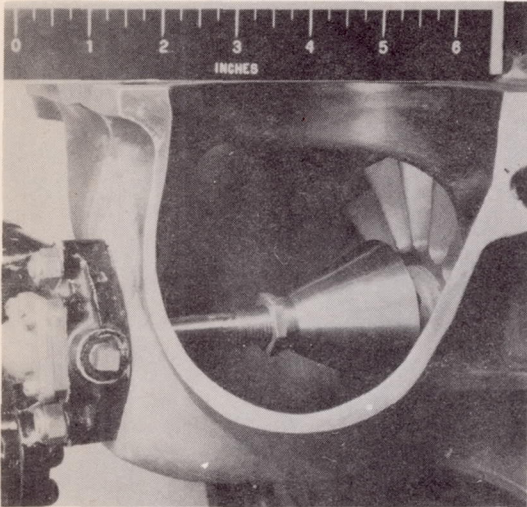

(i) Extended nozzle lowered to center line of impeller using a 360° hood.

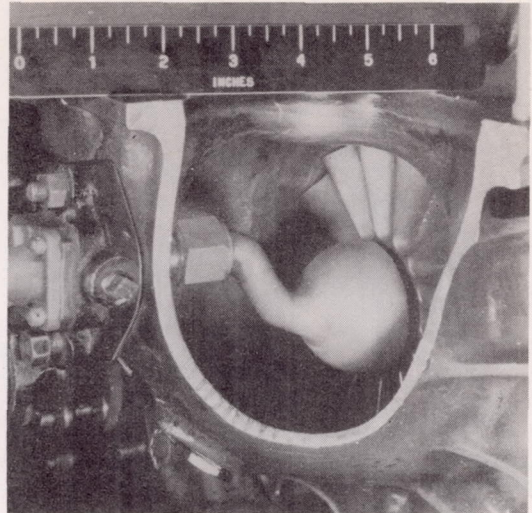

(j) Stationary shower-head type spray.

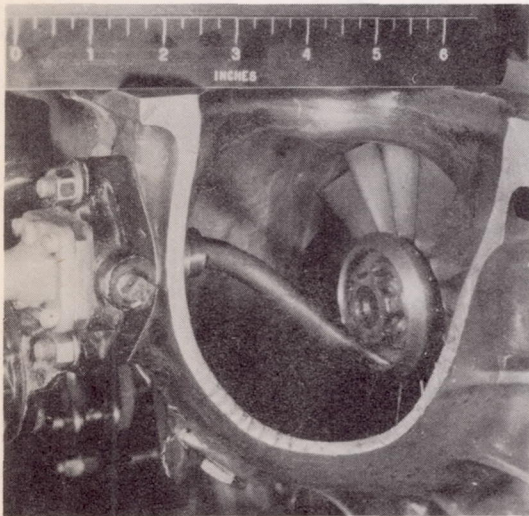

(k) A 15-hole cup-shaped spinner placed behind the impeller retaining nut.

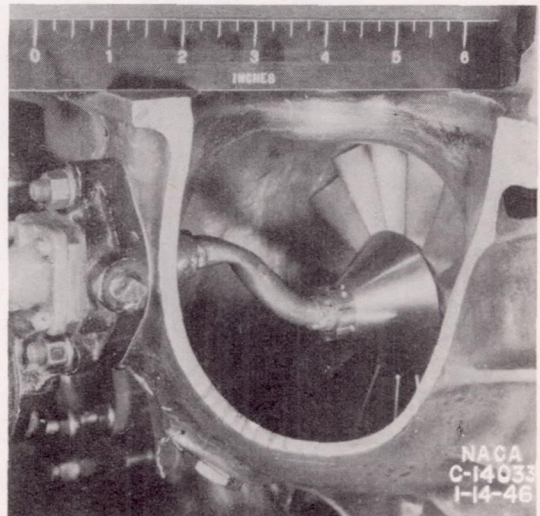

(l) Cone-shaped spinner containing 15 drilled passages and partly hollowed at the entrance.

Figure 2. - Continued. Fuel-nozzle modifications.

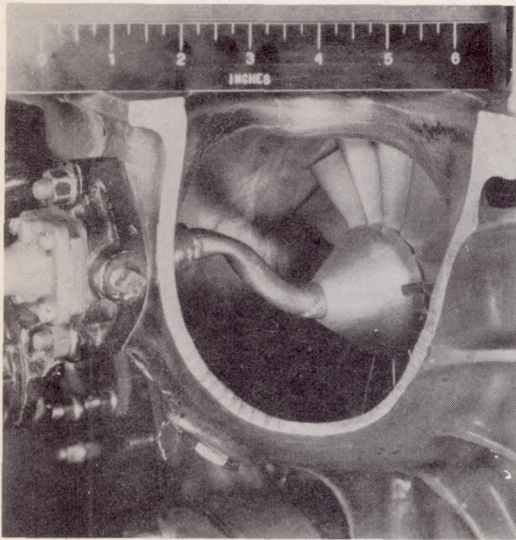

(m) Cone-shaped spinner containing a large inner cavity and fitted upon a revised and threaded impeller nut.

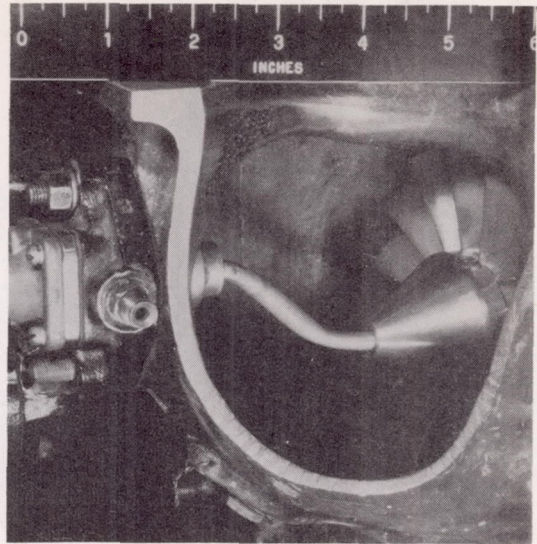

(n) A revision of figure 2(m) incorporating internal threads at the entrance of the spinner.

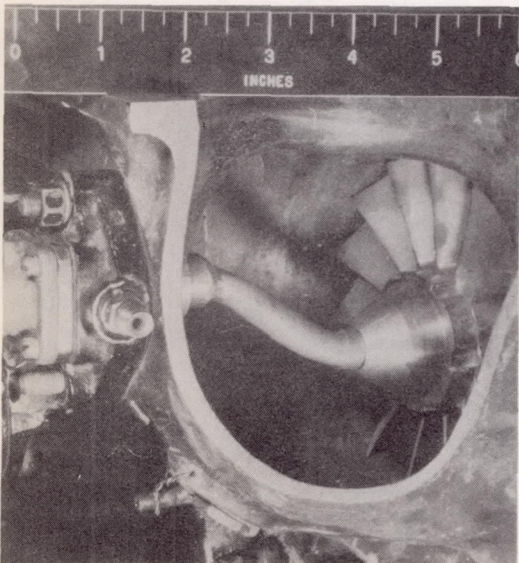

(o) Impeller-inducer injection using a spinner nut.

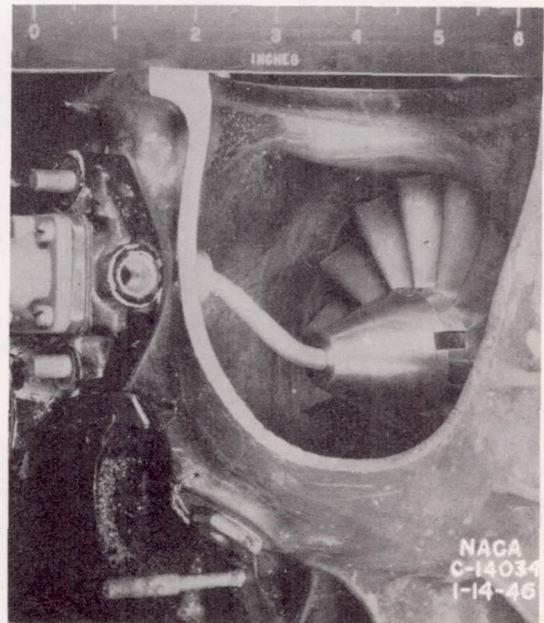

(p) A revision of figure 2(o) incorporating internal threads at the entrance of the spinner.

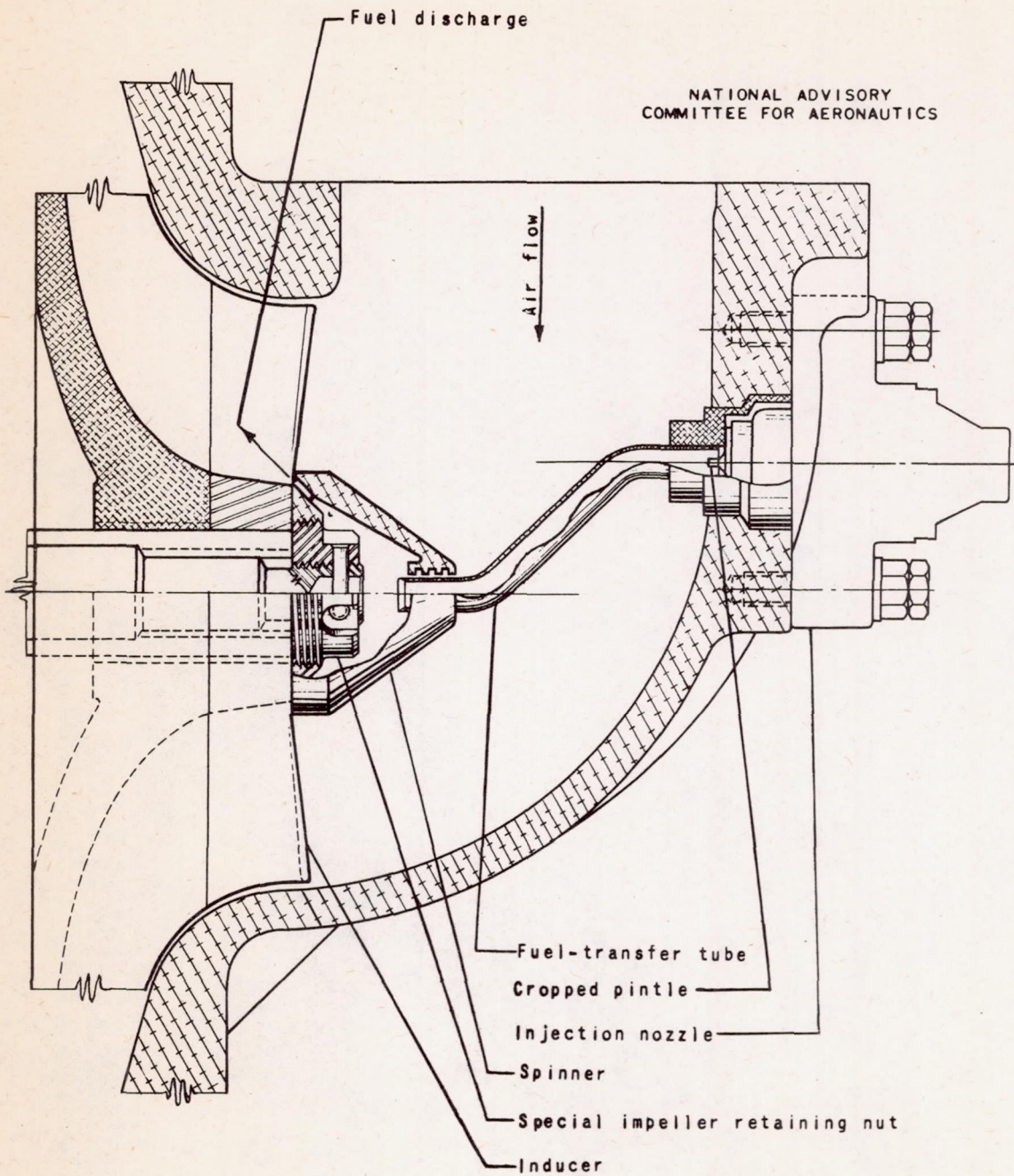

(a) Cross-sectional view of installation.

Figure 3. - Spinner fuel-injection system.

E-175

1847342

NATIONAL ADVISORY  
COMMITTEE FOR AERONAUTICS

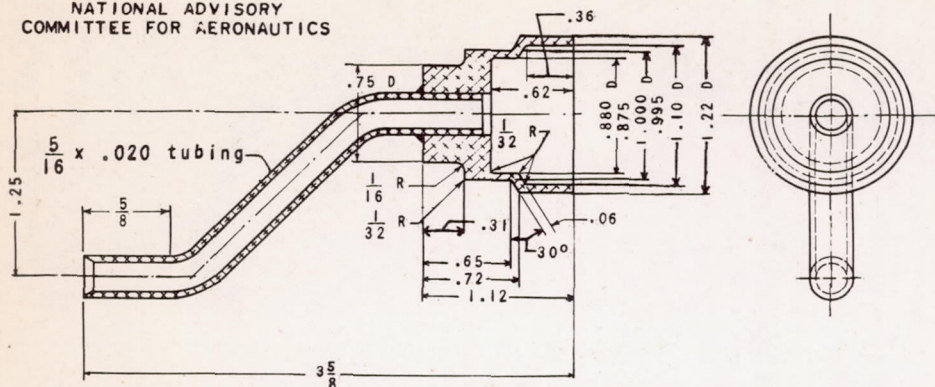

(b) Fuel-transfer tube.

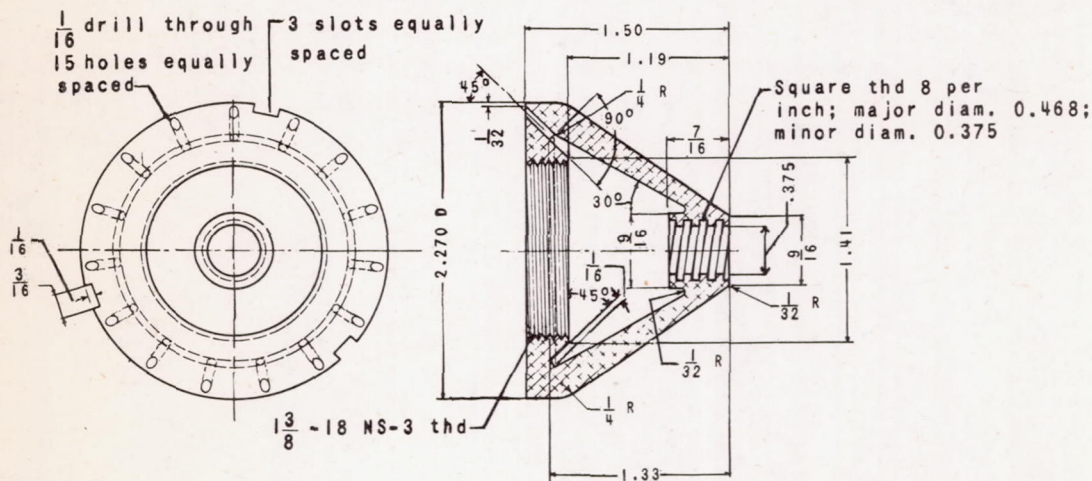

(c) Spinner.

Shot blast this face  
with #70 or #90 cracked grit

$\frac{9}{16}$  diam. tap drill  
c'sink 120° to  $\frac{21}{32}$  both  
ends tap  $\frac{5}{8}$ -18 NF-3 thd

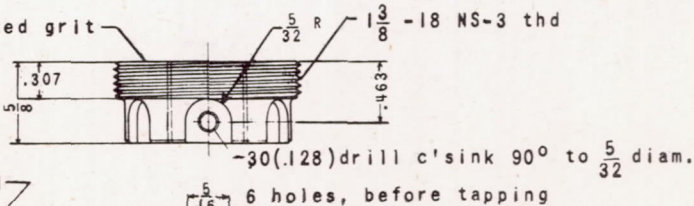

(d) Impeller retaining nut.

All dimensions in inches.

Figure 3. - Concluded. Spinner fuel-injection system.

E-175

184 1349

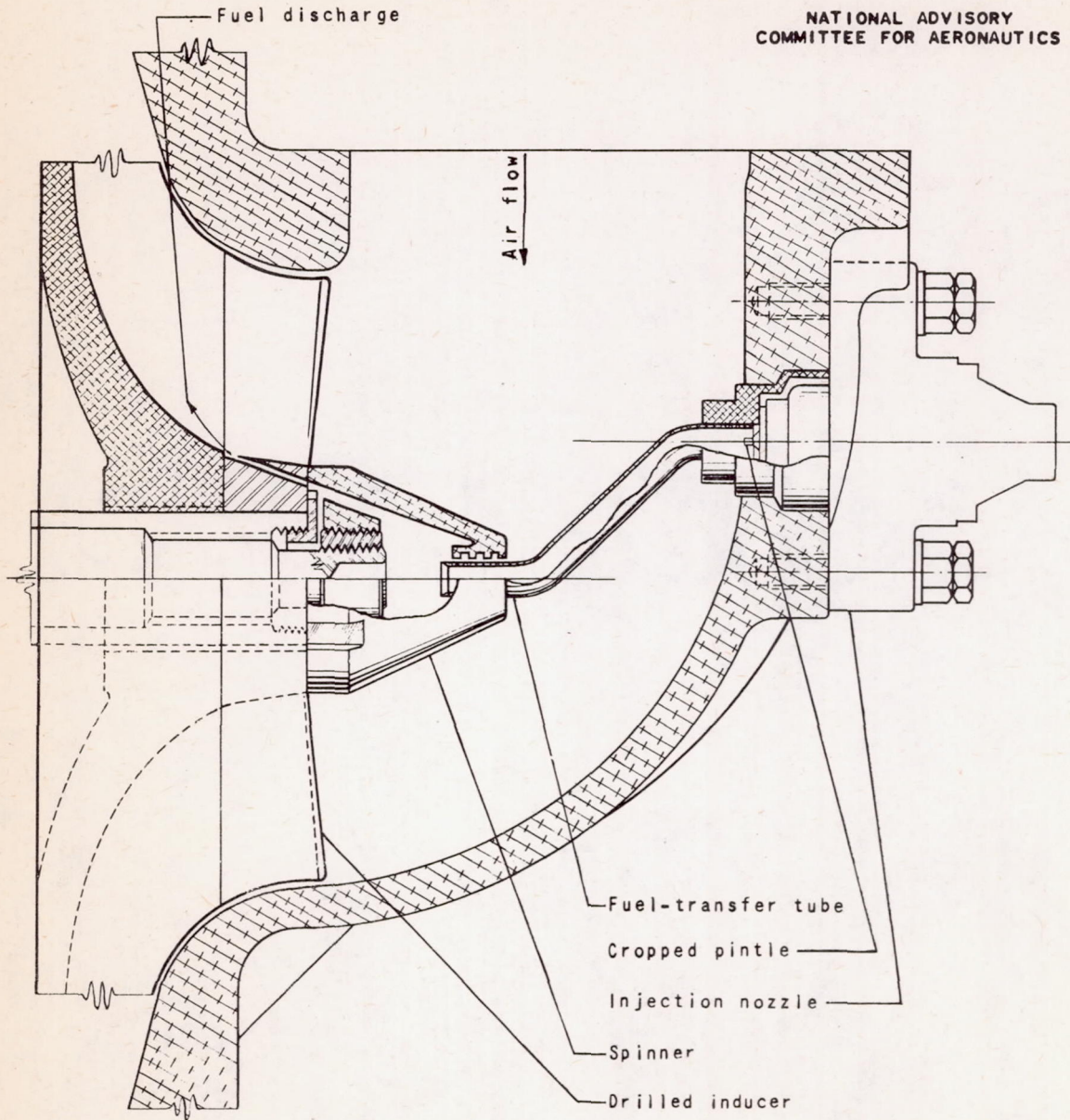

(a) Cross-sectional view of installation.

Figure 4. - Drilled-inducer fuel-injection system.

184+343

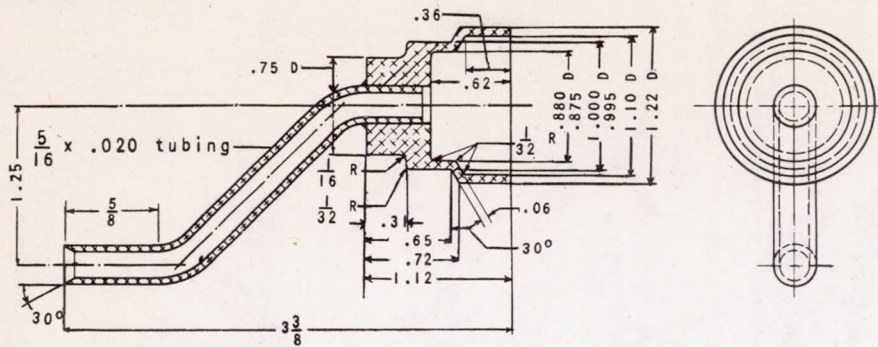

(b) Fuel-transfer tube.

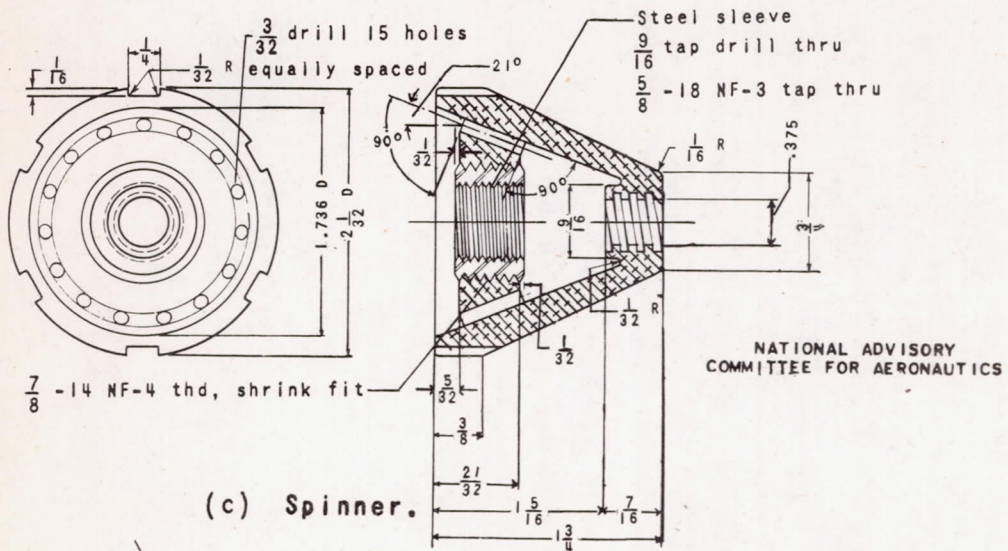

NATIONAL ADVISORY  
COMMITTEE FOR AERONAUTICS

(c) Spinner.

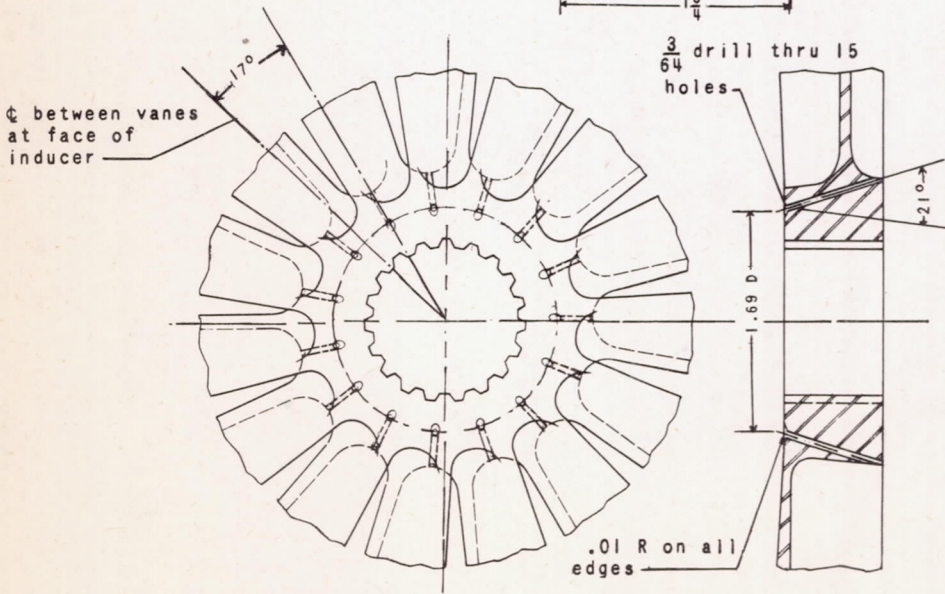

(d) Drilled inducer.

All dimensions in inches

Figure 4. - Concluded. Drilled-inducer fuel-injection system.

E-175

184 + 348



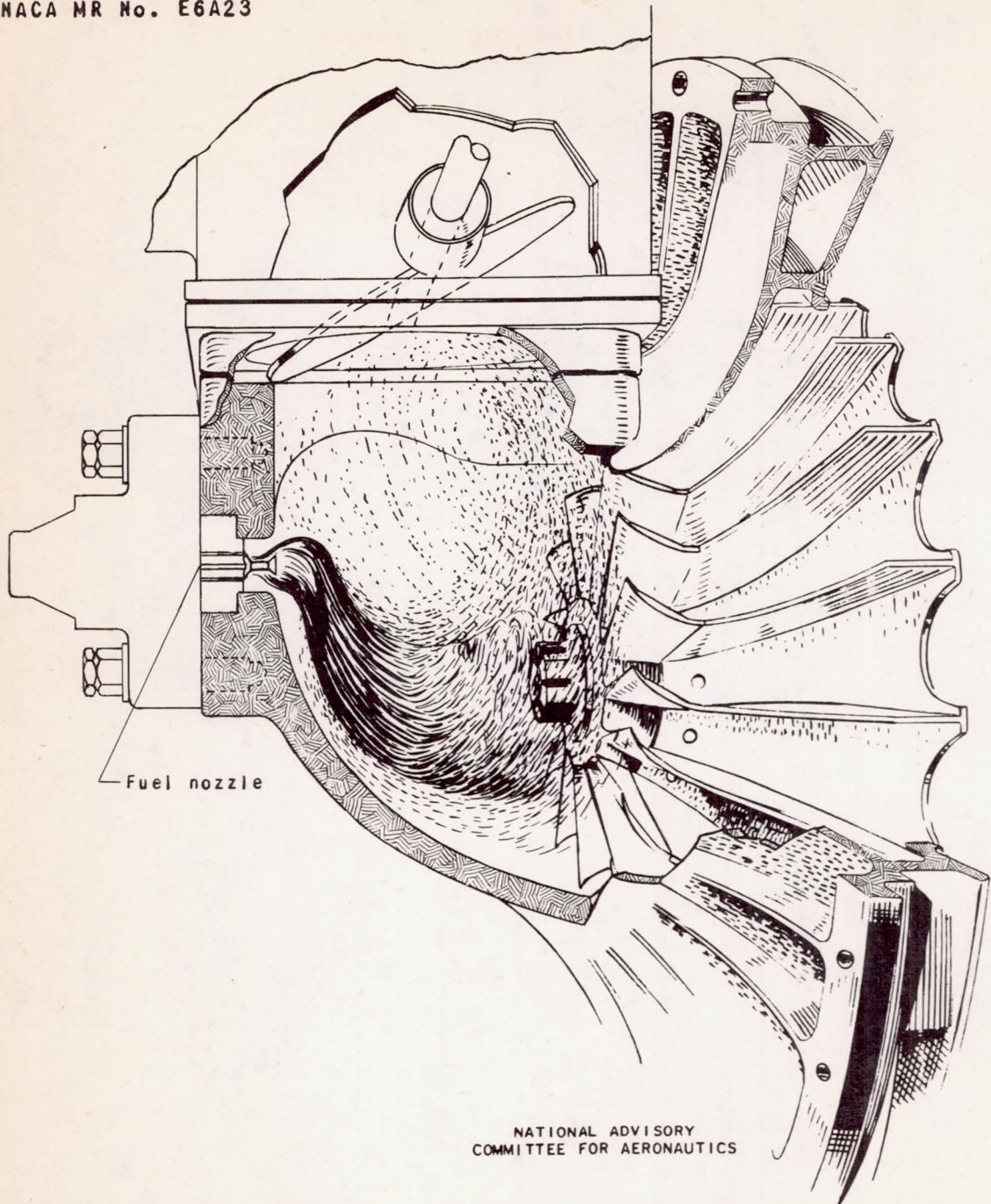

(a) Air flow, 4600 pounds per hour; fuel-air ratio, 0.080.  
Figure 5. - Fuel-spray pattern of Standard injection nozzle  
in the supercharger inlet elbow of an aircraft engine.

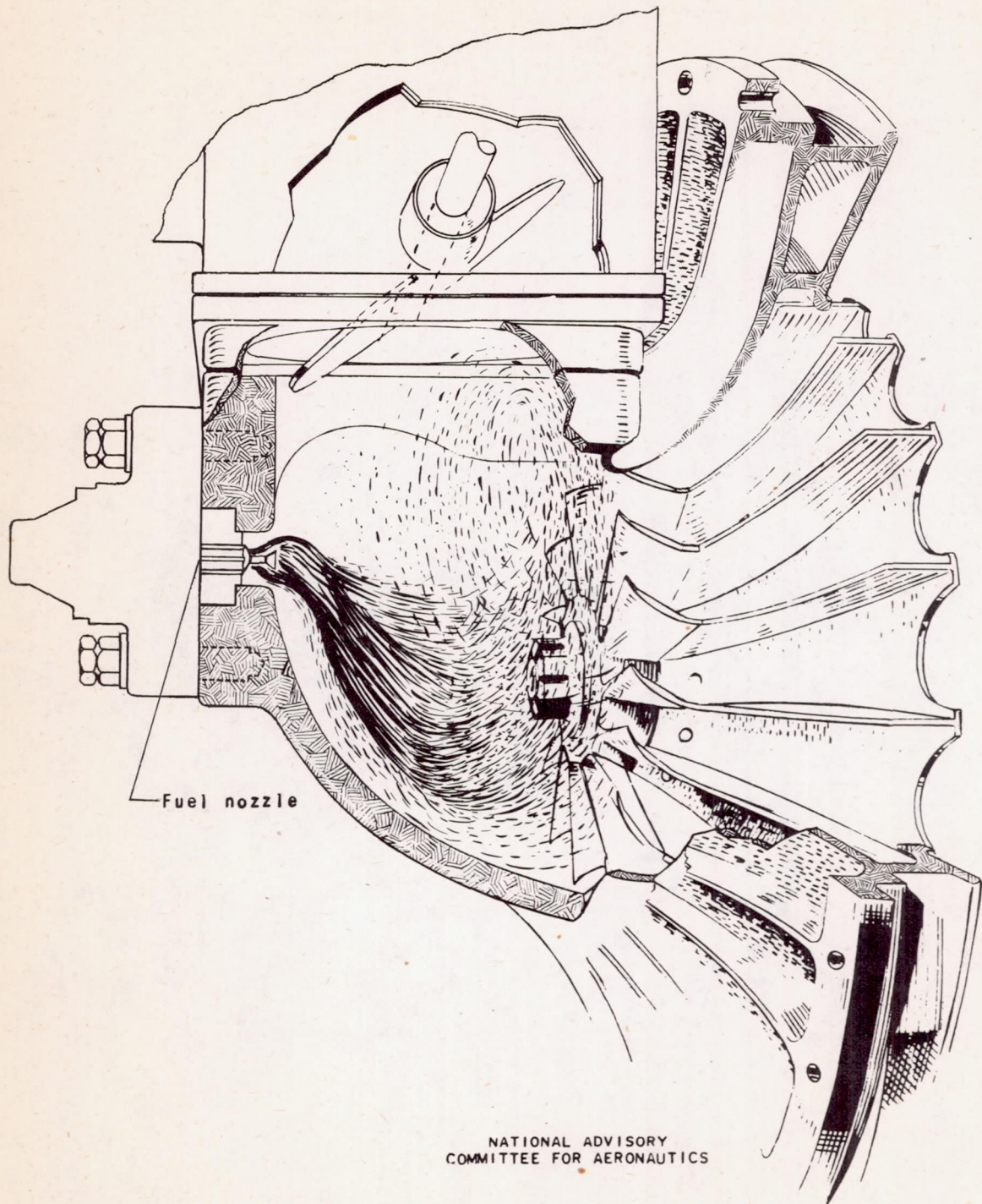

NATIONAL ADVISORY  
COMMITTEE FOR AERONAUTICS

(b) Air flow, 5775 pounds per hour; fuel-air ratio, 0.080.  
Figure 5. - Continued. Fuel-spray pattern of Standard injection nozzle in the supercharger inlet elbow of an aircraft engine.

E-175

59

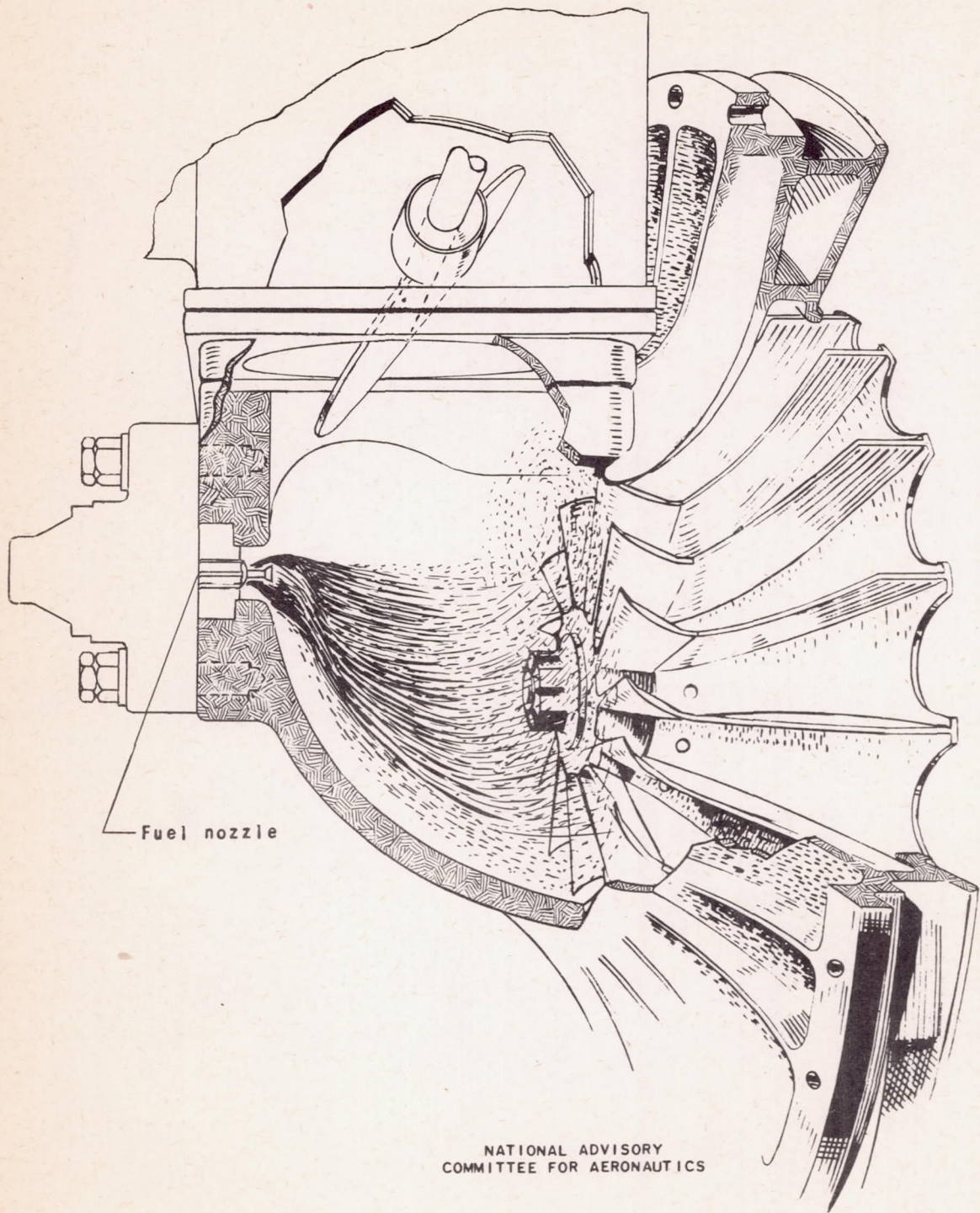

NATIONAL ADVISORY  
COMMITTEE FOR AERONAUTICS

(c) Air flow, 7700 pounds per hour; fuel-air ratio, 0.095.  
Figure 5. - Concluded. Fuel-spray pattern of Standard injection nozzle in the supercharger inlet elbow of an aircraft engine.

E-175

59

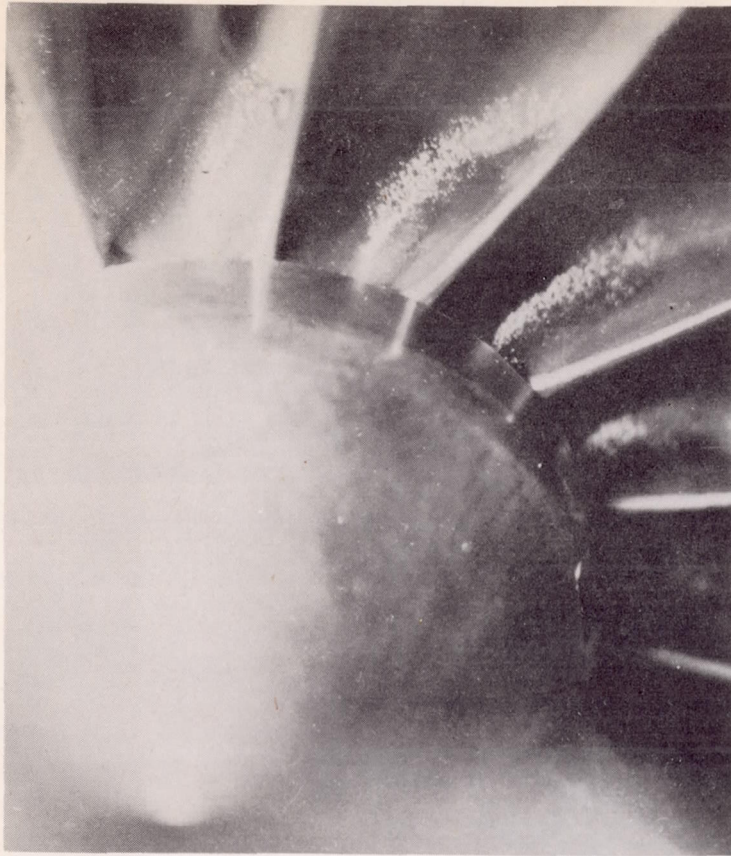

NACA  
C-9607  
4-13-45

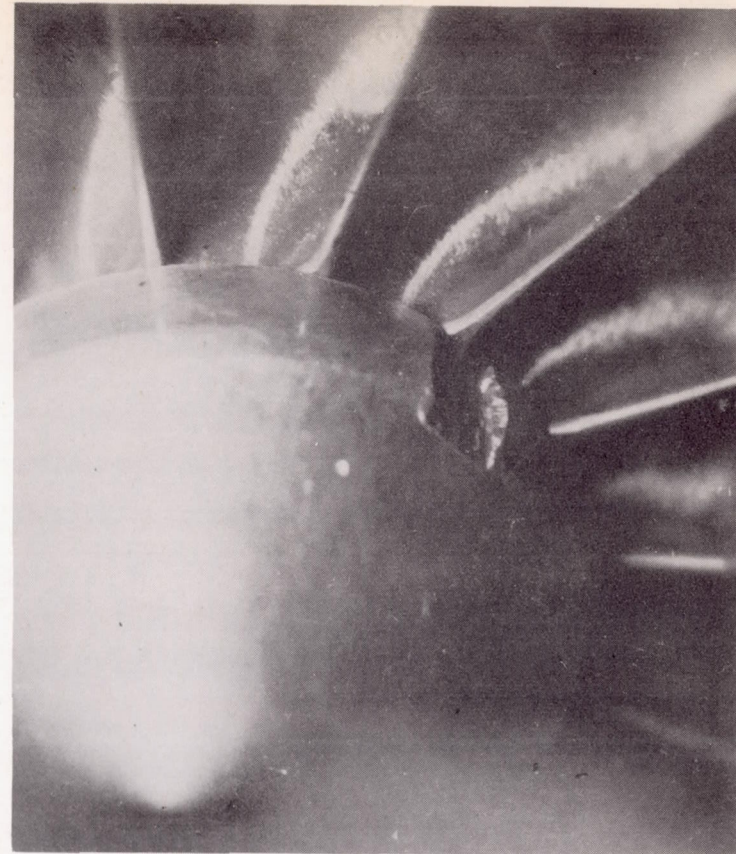

(a) Air flow, 4620 pounds per hour corresponding to 60-percent rated power; liquid flow, 372 pounds per hour corresponding to fuel-air ratio of 0.08; impeller speed, 17,800 rpm.

(b) Air flow, 10,300 pounds per hour corresponding to take-off power; liquid flow, 1080 pounds per hour corresponding to fuel-air ratio of 0.105; impeller speed, 24,300 rpm.

Figure 6. - Spray formation from the spinner fuel-injection system.

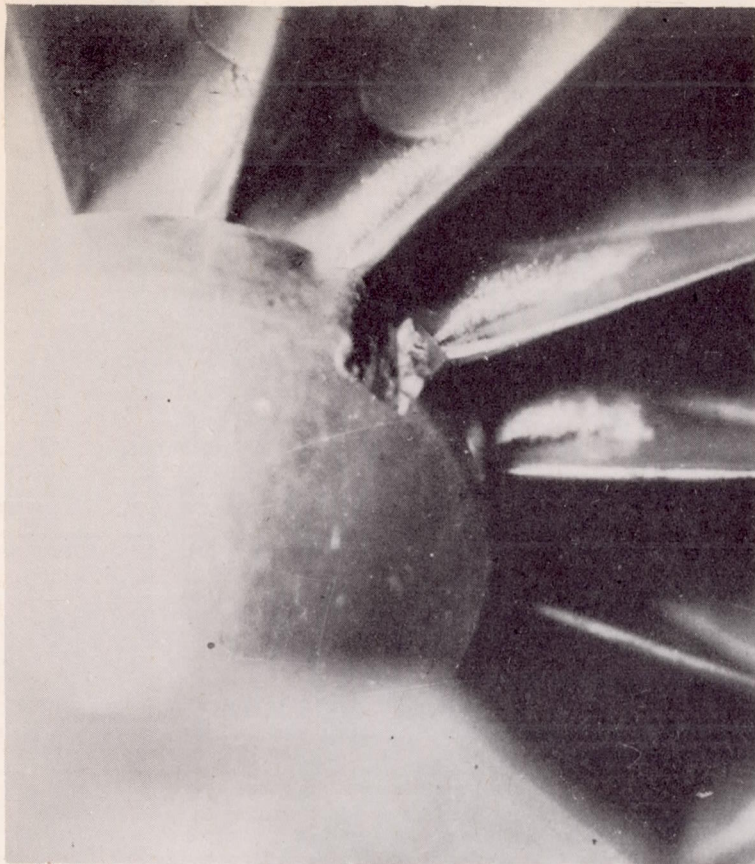

NACA  
C-9608  
4-13-45

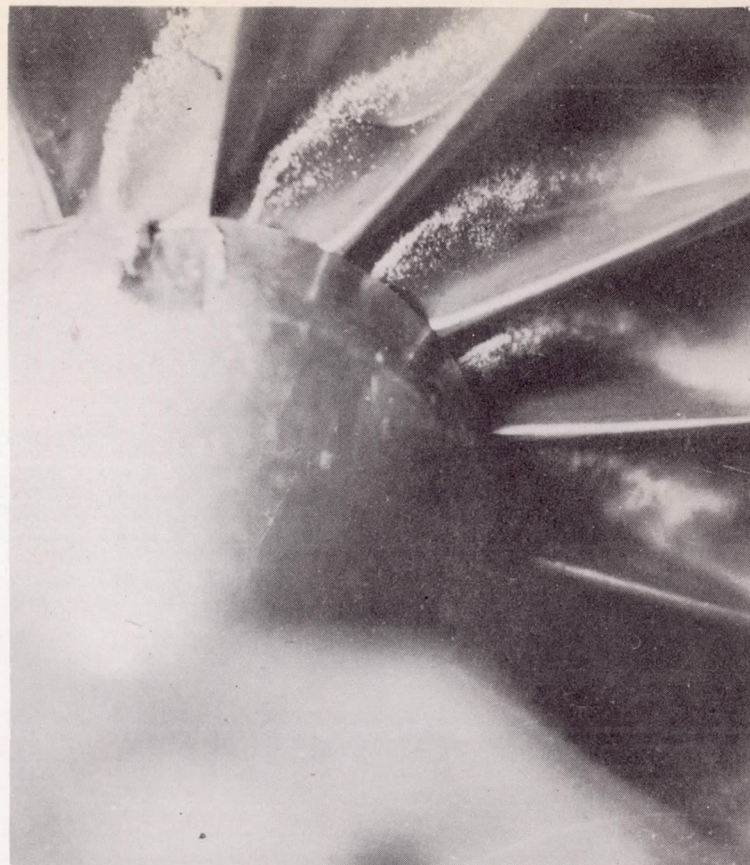

Fuel outlets in retarded position

Fuel outlet holes in advanced position

- (c) Air flow, 7700 pounds per hour corresponding to full rated power; liquid flow, 630 pounds per hour corresponding to fuel-air ratio of 0.082; impeller speed, 21,000 rpm.

Figure 6. - Concluded. Spray formation from the spinner fuel-injection system.

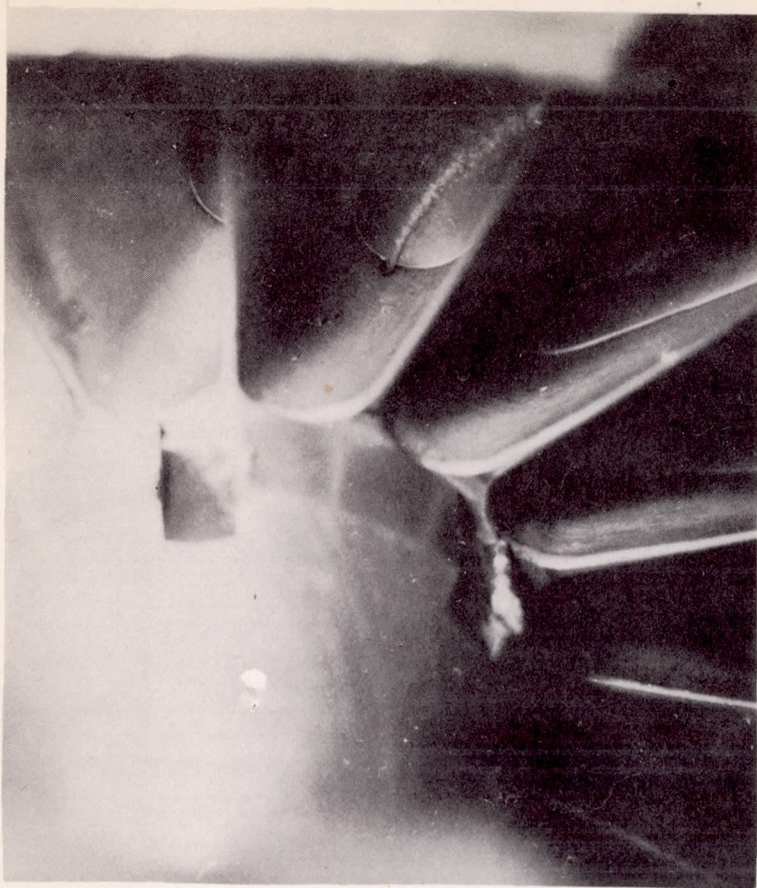

NACA  
C-9609  
4-13-45

- (a) Air flow, 4620 pounds per hour corresponding to 60-percent rated power; liquid flow, 372 pounds per hour corresponding to fuel-air ratio of 0.08; impeller speed, 17,800 rpm.

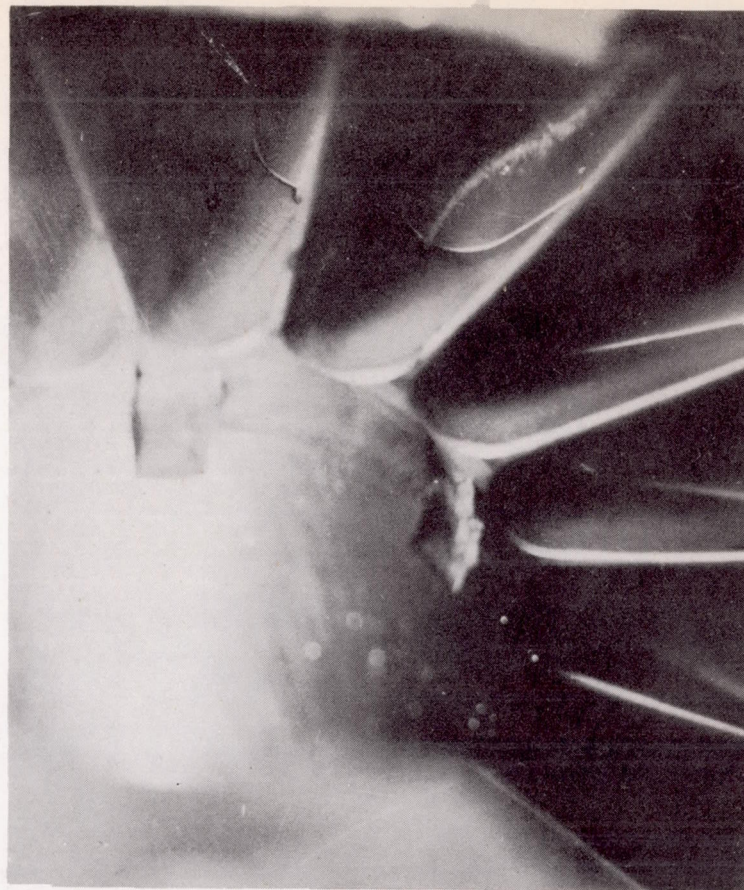

- (b) Air flow, 11,400 pounds per hour corresponding to war emergency power; liquid flow, 1200 pounds per hour corresponding to fuel-air ratio of 0.105; impeller speed, 24,300 rpm.

Figure 7. - Spray formation from the drilled-inducer fuel-injection system.