

MAY 12 1947

ARR Nov. 1942

*Copied*

NATIONAL ADVISORY COMMITTEE FOR AERONAUTICS

# WARTIME REPORT

ORIGINALLY ISSUED  
November 1942 as  
Advance Restricted Report

THE LONGITUDINAL STABILITY OF FLYING BOATS AS  
DETERMINED BY TESTS OF MODELS IN THE NACA TANK

II - EFFECT OF VARIATIONS IN FORM OF HULL  
ON LONGITUDINAL STABILITY

By Starr Truscott and Roland E. Olson

Langley Memorial Aeronautical Laboratory  
Langley Field, Va.

# NACA

WASHINGTON

NACA WARTIME REPORTS are reprints of papers originally issued to provide rapid distribution of advance research results to an authorized group requiring them for the war effort. They were previously held under a security status but are now unclassified. Some of these reports were not technically edited. All have been reproduced without change in order to expedite general distribution.

L - 468

LANGLEY MEMORIAL AERONAUTICAL  
LABORATORY  
Langley Field, Va.

## NATIONAL ADVISORY COMMITTEE FOR AERONAUTICS

## ADVANCE RESTRICTED REPORT

THE LONGITUDINAL STABILITY OF FLYING BOATS AS  
DETERMINED BY TESTS OF MODELS IN THE NACA TANK

## II - EFFECT OF VARIATIONS IN FORM OF HULL

## ON LONGITUDINAL STABILITY

By Starr Truscott and Roland E. Olson

## SUMMARY

Results of investigations of the longitudinal-stability characteristics of several models are considered in an attempt to arrive at general conclusions as to the effects of variations in the form of hull on these characteristics. Data are used from tests at constant speed, establishing the trim limits of stability; from tests at accelerated speeds, establishing the limits for stable positions of the center of gravity; and from tests at decelerated speeds, establishing the landing characteristics. The conclusions drawn are not necessarily final but the available information indicates certain trends that are offered as a guide to future tests and design.

The lower trim limit of stability is not appreciably affected by changes in position of center of gravity, position of step, plan form of step, depth of step, angle of afterbody keel, and length of afterbody. A reduction in the angle of dead rise decreases this limit to lower trims. An increase in gross weight raises this limit to higher trims.

The upper trim limits of stability are not appreciably affected by a change in position of center of gravity. Moving the step aft appears to raise the limits slightly. These limits are raised to higher trims by an increase in gross weight, an increase in depth of step, an increase in angle of afterbody keel, a decrease in length of afterbody, and by ventilation of a shallow step. These limits are changed by a variation in the plan form of the step in proportion to the changes in the effective depth of step and the effective position of the step.

The limits for stable positions of the center of gravity are shifted by a distance approximately equal to the distance the centroid of the step is moved. Increasing the depth of step does not appreciably change these limits. With heavier gross weights the range of stable positions for the center of gravity is reduced.

Instability in landing at high trims is reduced or eliminated either by increasing the depth of step or by ventilating the step. A depth of step of the order of 8 percent of the beam has been found necessary. Large ventilation ducts located near the keel and just aft of the step are effective, but ventilation ducts near the chine are ineffective. With a depth of step of 5.5-percent beam, the landing instability of one model was not eliminated by varying the angle of afterbody keel from  $4^{\circ}$  to  $8.5^{\circ}$  and increasing the length of afterbody from 161 to 311 percent of the beam.

## INTRODUCTION

Several models of flying boats have been investigated at the NACA tank in an effort to determine their longitudinal-stability characteristics. Part I (reference 1) of this report describes the methods that have been used at the tank. The models usually represented specific designs; generally either the full-size airplane had been built or the construction was at an advanced stage before tests of the model were requested. The possible modifications were, therefore, limited to small changes that were expected to improve the stability characteristics without appreciably altering the existing design.

With such an approach to the problem of longitudinal stability, the greater part of the research has consisted of a number of unrelated tests, each of which was made for the specific purpose of improving the stability of a particular design. The investigations have been restricted to the essentials because of the limited time that could be allotted to any single test. A complete study of the effects of all the modifications was therefore impossible, and in many instances the data are incomplete. Repetition during the several tests has been large, and the contribution of any single test to the general problem has often been small.

1-468

A study of these tests has been made for the purpose of determining what general conclusions may be drawn from them as to the effects of variations in the form of the hull on the porpoising characteristics of the complete model. In some instances the data are meager and the conclusions are not necessarily final. All these tests have been made without powered propellers.

### DATA

Wherever possible, the data on which the conclusions of this report are based are presented in the form of curves. These curves, in turn, are based directly on data obtained from tests of a number of different models and represent what are believed to be the most reliable data obtained from these tests.

The stability characteristics of the different models are not compared because they generally represent entirely different designs and the aerodynamic characteristics of most of the models were not determined. Aerodynamic tests also show a large scale effect as evidenced by decreased angle of stall. Since the aerodynamic lift cannot be predicted with any degree of accuracy, the load on the water at any particular speed cannot be determined with sufficient precision to justify conclusions as to the relative merits of the several models. Aerodynamic data are not being determined for each model as a routine portion of the test program.

### TRIM LIMITS OF STABILITY

The trim limits of stability are defined as the trims that separate the stable range of trims from the unstable range. These limits are determined by varying the trim at constant speed and observing the trim at which porpoising first appears. This procedure is described in detail in reference 1.

Three trim limits of stability exist for models of conventional flying boats. The lower trim limit of stability,

representing the limit to which the trim may be decreased before porpoising occurs, generally appears as the stern post emerges from the water. The speed at which instability appears therefore corresponds very nearly with the hump speed, at which maximum resistance is obtained. The motion is principally an oscillation in pitch, and the violence increases with further departure in trim below the limit. At intermediate planing speeds when the trim is near the lower limit, the load on the water is carried by the forebody alone and the stern post and the afterbody are entirely clear of the water. At high speeds the change in the lower limit with speed is small. The forebody carries practically the entire load on the water and only spray strikes the afterbody.

The upper limit, increasing trim, represents the limit to which the trim may be increased before porpoising is encountered. Indication of the presence of high-angle porpoising or the existence of an upper trim limit of stability has been found in tests of all dynamic models of flying boats towed in the NACA tank. This limit first appears at intermediate planing speeds and is generally present throughout high speed to take-off. The porpoising motion is principally in rise, and a small departure in trim above the limit causes violent porpoising. A further increase in trim does not greatly affect the violence of the motion.

After porpoising at high trims is established, the trim must be decreased below the upper limit, increasing trim, before stability is recovered. The trims of recovery define the upper limit, decreasing trim. The separation between the two upper limits is at first small but increases rapidly with speed. When the porpoising motion ceases, the trim generally decreases suddenly, which indicates that an excess of negative pitching moment was required in order to recover stability. This limit cannot be determined near got-away speed, because the model takes off when the trim increases and the porpoising becomes erratic.

The following trends in the effects of changes in the several items are noted from a study of the results of the tests of a number of models:

Effect of change in gross weight.— An increase in gross weight generally raises all the trim limits of stability toward higher trims. Typical results, representing data obtained for three different models, are shown in figures 1, 2, and 3. In all the figures of this report, the gross load coefficient  $C_{\Delta_0} = \Delta_0 / wb^3$

where

$\Delta_0$  initial load on water, gross load, pounds

b maximum beam of model, feet

w specific weight of water, pounds per cubic foot

At high speeds the lower limits tend to converge and the change in limit with load is less marked. The curves of figure 1, which show the lower limits for several values of the gross weight, actually cross and a discontinuity or sudden decrease in trim occurs. The afterbody interference apparently has some influence on the lower limit at these speeds.

The upper limit, increasing trim, is raised as the gross weight is increased and the speed at which it is first obtained is also increased. The upper limit could be obtained at lower speeds by applying external moments or by changing the position of the center of gravity. This information would be more academic than practical. The pitching moments used for these tests include the maximum that can be obtained from the tail group at positions of the center of gravity used in flight.

It has been observed that the upper limit is raised as the load is increased. If afterbody clearance is a factor upon which the position of the upper limit depends, then this limit would probably be raised because the depth of the wake is greater at the heavier loads. Higher trims are therefore necessary to establish a flow over the afterbody comparable with that at light loads. The problem of afterbody clearance will be further considered in connection with the effects of depth of step, ventilation, length of afterbody, and angle of afterbody keel. The available data appear to indicate that the upper limit, decreasing trim, is raised as the load is increased. Many inconsistencies are found that are mainly due to the difficulty in obtaining this limit. (See reference 1.) With heavier loads, the porpoising appears to be more violent and difficult to control.

In a parallel investigation conducted at Stevens Institute of Technology with a 1/30-size model, the same general trends were observed, but actual values and details of behavior were different from those obtained in the NACA tank when a 1/10-size model of the same flying boat was tested.

Effect of change in position of center of gravity.- Data relative to the effect of horizontal movement of the center of gravity on the trim limits of stability are contradictory. The available data that are considered as most accurate are presented in figures 4, 5, and 6. (Similar data have been obtained from tests of other models, but in these cases deformations of the model during the tests have been so great as to make the data of dubious value for use in drawing general conclusions.) The acceptable data indicate that the lower limit is not appreciably changed by changing the position of the center of gravity. The effect on the upper limits is not entirely conclusive. An examination of the data indicates that the upper limits may be considered, within the accuracy of their determination, as unchanged by movement of the center of gravity. Since the flow over the aerodynamic and hydrodynamic surfaces is the same at any given trim, regardless of the position of the center of gravity, the limit at which porpoising starts should be independent of the position of the center of gravity. Some differences might be expected in the upper limit, decreasing trim, inasmuch as this limit represents the trim at which the model recovers from a porpoising condition. A change in the position of the center of gravity would be expected to change the effectiveness of the damping forces of the aerodynamic surfaces.

The principal effect of a change in the position of the center of gravity is the change in control moment. In figure 4 the upper limits, increasing trim, could not be reached at forward positions of the center of gravity and the lower limit was incomplete at the aftmost position of the center of gravity. Trims with full-up and full-down elevators, with the center of gravity at 28 percent mean aerodynamic chord, are shown in this figure.

No complete data are available relative to the effect of vertical changes in the position of the center of gravity of a complete model on the trim limits of stability. In tests of a single planing surface, the vertical position had very little effect on the trim limit (lower limit).

Effect of depth of step.- The effect of varying the depth of step was discussed in reference 1. Additional data obtained from tests of other models are shown in figures 7 and 8. The same trends as reported in reference 1 are noted. The lower limit is not appreciably affected by change in depth of step and the upper limits are raised

with increase in depth of step. In figure 8 the upper limit, increasing trim, at a load of  $C_{\Delta_0} = 0.97$  and with the deep step could not be obtained with the available control moment.

The afterbody clearance appears to be the important feature of the planing bottom that affects the upper limit. The increased depth of step raises the whole afterbody and provides more clearance and better ventilation of the step.

The trends produced by increasing the depth of step are generally substantiated by the results of similar tests that have been made in the small tank at Stevens Institute of Technology.

Effect of change in position of step.— Trim limits of stability obtained for different positions of the main step are shown in figures 9 and 10. The modifications shown in figure 9 involve no change in depth of step as the transverse step is moved; whereas that shown in figure 10 produced an increase in depth of step of 3.3-percent beam.

Changing the position of the step caused only small and inconsistent changes in the lower limit at intermediate planing speeds. Greater differences, without definite order, were found at high speeds, but these differences may be generally attributed to changes in smoothness of the forebody planing surfaces. No appreciable difference in the lower limit at intermediate speeds is to be expected, inasmuch as the model is planing on the forebody and any change in the position of the step is similar in effect to an opposite change in the position of the center of gravity. Change in the afterbody interference with change in the position of the step may have a small effect on the lower limit at high speeds.

The results shown in figure 9 indicate that the upper limits are raised as the step is moved aft. This indication is not conclusive, inasmuch as some discrepancies appear for the loads shown in the figure and for other loads that were investigated but not included in this report.

Changes in the position of the step change the hydrodynamic moments, which, in turn, change the range of trims that can be obtained with the available aerodynamic control moment. The change in hydrodynamic moment is more important than any small differences in trim limits. This effect will be considered further in connection with the determination of

894-1



the proper location of the step by tests in which accelerated runs are used.

Effect of change in plan form of step.— When the plan form of the step is changed, both the position and the depth of step are changed. The effects of these changes must be considered in determining the relative merits of any particular plan form. Data showing the effect of modifications of the plan form of the step on the trim limits of stability are included in figures 9 to 13. These modifications of the plan form include transverse, Vee, notched, swallow-tail, curved, and breaker steps.

Within the limits of accuracy of these tests, the lower limit of stability is unchanged by a change in the plan form of the step. Small differences occur near hump speeds when the afterbody comes clear and again at high speeds where the spray striking the afterbody is changed by the modified steps.

Data regarding the upper limits are incomplete. In figure 9, the upper limits obtained with the curved steps are higher than those obtained with the transverse steps. The fact that the curved step is also effectively farther aft than are the transverse steps may partly explain the increase in the trim limit. The data relative to the upper limits, shown in figures 10 and 11 for notched and swallow-tail steps, are incomplete; but the general conclusion is that the improvement noted in the behavior during take-off and landing may be attributed to the increase in the depth of step rather than to a change in the plan form.

The data for the upper limit, shown in figure 12, are not consistent and represent the early efforts at investigating this limit.

Effect of ventilation.— Observations of the flow of water at the main step during high-angle (upper-limit) porpoising indicate that during a part of the cycle the water completely seals the step and actually wets the afterbody just behind the step. Observations of the flow of water behind the step and of the reduction in violence of upper-limit porpoising with increase in depth of step indicate that a ventilation of the step would be beneficial. Measurements of the pressure behind the step during upper-limit porpoising show that a definite negative pressure is developed.

In order to improve the stability at high trims and high speeds, ventilation of the main step has been investigated. The forebody and afterbody of a model having particularly bad landing characteristics were separated at the step in order to allow air to flow under the afterbody from the interior of the model. The width of this slot was varied and different parts of the slot were sealed at the afterbody bottom during the tests. The trim limits, with a 1/2-inch vent extending over the beam of the model, are shown in figure 14. Ventilation has small effect on the lower limit; the upper limits are not only raised to higher trims but also do not appear until higher speeds are reached.

This investigation was extended by a series of simulated take-offs and landings. These tests show that the sudden increase in trim of the original model at take-off and the subsequent skipping on landing are eliminated by proper ventilation.

Ventilation by means of an air duct in the form of a 1/4-inch slot between the forebody and the afterbody reduced the instability on landing but did not eliminate it. With a 1/2-inch slot, the model took off with no increase in trim and landed with neither porpoising nor skipping. This improvement indicates that the 1/4-inch slot did not provide sufficient ventilation completely to eliminate instability. Slots 1/2 inch wide and extending 1/4 beam in from each chine were ineffective, but similar ventilation over the center portion of the beam was almost as effective in the elimination of the instability in landing as ventilation over the entire beam of the model.

The effect of ventilation on the trim limits of another model is shown in figure 15. For this model the upper limit, increasing trim, appeared at a higher speed with ventilation, but otherwise the limit was not appreciably changed. The lower branch of the upper limit (decreasing trim) was slightly raised. The chief effect noted was a definite decrease in the violence of the porpoising. The tendency of the model to increase trim on take-off and to porpoise or skip on landing at high trims was reduced by ventilation.

Ventilation of the step of two other models that had definite instability characteristics on landing was unsuccessful. Ventilation for the first of these models was supplied through eight 1/2-inch-diameter holes located on the vertical surface of the step. These holes opened

into a manifold that, in turn, was open to the air at the side of the model just forward of the step. In these tests the ventilation was incomplete, inasmuch as the ducts were not close to the keel and the entrance duct was comparatively small.

The second model showed a definite instability at high speeds and high trims. In this case, ten  $3/16$ -inch-diameter tubes were installed in the model. The lower ends of these tubes were located just aft of the step and were spaced at  $1/2$ -inch to  $1\frac{1}{2}$ -inch intervals along the beam of the model. These tubes were attached to a  $6/16$ -inch manifold. Again the ventilation was very incomplete.

The necessity for ventilation is apparently due to the development of negative pressures caused by a mechanical entrainment of the air. Complete ventilation is provided only by means of large ducts located near the keel. A volume of air much greater than has been thought necessary must be supplied at the center portion of the step.

Effect of length of afterbody.— The effect of length of afterbody on the trim limits of stability is shown in figures 16 and 17. Within the accuracy of the tests, the lower limit of stability is not changed by changing the length of the afterbody, although some differences may be present at low speeds where the limit first appears. The limit first appears as the afterbody comes clear of the water and the exact determination of the limit is difficult. Tests of models of flying boats and tests of planing surfaces (reference 2) both indicate that lower-limit porpoising is a forebody phenomenon and modifications of the afterbody length would therefore have only a very secondary effect on the position of the limit. After porpoising is established, however, the damping forces of the afterbody probably alter the character of the motion.

The upper limits of stability, increasing trim and decreasing trim, are raised as the afterbody length is reduced. This result indicates that an increase in afterbody clearance tends to increase the range of stable trims. The violence of the porpoising is not appreciably changed as the afterbody length is decreased.

Effect of angle of afterbody keel.— The effect of variation in the angle of afterbody keel on the trim limits of stability is shown in figures 18 and 19. Only the lower limit was determined for the tests shown in figure 19. As

would be expected, the effect of a change in the angle of afterbody keel on the lower limit of stability is negligible. Increasing the angle of afterbody keel increases the afterbody clearance and raises the upper limits of stability. The violence of the porpoising is not appreciably changed with the greater angles of afterbody keel. With the highest angle of afterbody keel (fig. 19), the motion is almost entirely vertical with negligible change in pitch.

Effect of angle of dead rise.- A theoretical and experimental determination of the effect of the angle of dead rise of a planing surface on the lower limit of stability has been made. The computed and the experimental values for the lower limit are both decreased with a decrease in the angle of dead rise. (See reference 3.)

Further research is necessary in order to determine the effect of this variable on the upper trim limits.

Effect of pointed step.- Lower-limit porpoising is attributed to the character of the flow over the forebody or single planing surface. Upper-limit porpoising is attributed to the character of the flow over the forebody and afterbody and is present only when two or more planing surfaces are used.

In an effort to eliminate the upper trim limits of stability or to reduce the possibilities of having high-angle porpoising occur, tests were made of a model with a pointed forebody similar to that used in the NACA model 35 series (reference 4).

The first tests were made with tandem planing surfaces simulating the planing bottom for a flying boat. These tests were discontinued because the porpoising motion was so violent that this particular model was considered impracticable.

Further tests were made by use of a model of a conventional airplane with a transverse step and of the same model with a pointed step. The curves showing the trim limits of stability of both models are shown in figure 20. At constant speeds the model with the pointed step is, in general, more unstable than the model with the transverse step. The separation between the upper and lower limits is reduced. The tendency to skip on landing was eliminated, however, by the use of the pointed step.

Miscellaneous modifications.- In addition to the changes previously mentioned, a number of other modifications have been tried, such as breaker steps, fairings behind the main step, and spray strips. The improvements, if any, have been negligible and generally the tests have been discontinued without obtaining complete data.

#### LIMITS FOR TRAVEL OF THE CENTER OF GRAVITY

The positions of the center of gravity at which the model is stable during acceleration are determined by the method of accelerated runs. This method was described briefly in reference 1, but the details of the method and the use of the data were omitted. (See also reference 5.)

Accelerated runs are made, with various settings of the elevators, and the trims and the amplitudes of porpoising are noted. This procedure is repeated for successive forward and after positions of the center of gravity until the positions at which porpoising occurs are determined. Typical test results are presented in figures 21 and 22. Trim is plotted against speed for several loads at positions of the center of gravity ranging from forward positions at which porpoising took place to after positions at which porpoising occurred.

The porpoising observed during these accelerated runs is associated with the trim limits obtained at constant speed. As the center of gravity is moved forward, the free-to-trim attitudes are decreased because of the more negative hydrodynamic trimming moments. A forward position of the center of gravity is finally obtained that causes the trim (with neutral elevators) to pass below the lower trim limit of stability, and porpoising occurs. This result is shown in figure 23, where the data obtained at several positions of the center of gravity are superimposed on the curves showing the trim limits of stability. With the center of gravity at 28 percent mean aerodynamic chord, the free-to-trim curve with neutral elevators falls between the upper and lower trim limits of stability. With the center of gravity at 24 percent mean aerodynamic chord, however, the free-to-trim curve with elevators neutral crosses the lower trim limit of stability. Porpoising at forward positions of the center of gravity is therefore associated with lower-limit porpoising. The motion is

mainly an oscillation in pitch and generally reaches a maximum and then decreases with further increase in speed. The violence of porpoising increases slowly with further forward movement of the center of gravity.

As the center of gravity is moved aft, the free-to-trim attitudes are increased because of the more positive hydrodynamic trimming moments. An after limiting position of the center of gravity is finally obtained that causes the trim (with up elevators) to cross the upper trim limit of stability, and porpoising occurs. This effect is shown in figure 23 with the center of gravity at 32 percent mean aerodynamic chord and full-up elevators. Porpoising at after positions of the center of gravity, therefore, is associated with upper-limit porpoising. A small change in the after position of the center of gravity may produce violent porpoising. The motion is principally in rise and the amplitude generally increases with increase in speed. This motion is called divergent porpoising, as opposed to the convergent porpoising encountered at forward positions of the center of gravity.

The maximum amplitude of porpoising, one of the principal measures of violence, is determined from plots similar to those shown in figures 22 and 23 and is plotted against position of the center of gravity as shown in figures 24(a), 24(b), 25(a), and 26(a). From these curves the range of positions of the center of gravity that are stable may be determined.

When the range of stable positions for the center of gravity is determined, the following assumptions are made:

1. The maximum permissible amplitude of porpoising is no greater than  $2^{\circ}$ . (See reference 5.) This amount of porpoising would not be considered dangerous from considerations of either control of the airplane or forces on the structure of the hull.

2. The range is determined from a condition of neutral elevators at forward positions of the center of gravity to full-up elevators at after positions. This procedure presupposes a recovery from a porpoising condition by increasing the elevator deflection at forward positions and decreasing the elevator deflection at after positions. On the basis of these assumptions the range of travel of the center of gravity is plotted against load in figures 24(c), 25(b), and 26(b).

Before these data are discussed in detail, a few of the limitations that are present in this method of testing will be considered. The aerodynamic forces, lift and control moment, of the full-size airplane must be simulated for the model if the data are to be applied to the full-size airplane.

The rates of acceleration must be reproduced as nearly as possible if the results are to be consistent. Runs made at different rates of acceleration have different amplitudes of porpoising and, in general, the higher the rate of acceleration, the smaller the amplitude. With the present speed control of the towing carriage, it is difficult to reproduce accurately the rate of acceleration. This fact may account for a few of the inconsistencies appearing during this type of test. The data obtained are, however, adequate for locating the range of stable positions for the center of gravity of the model and, apparently, for determining the best fore-and-aft location of the step on the airplane. If additional refinements are necessary, either the technique of making the run or the method of controlling the speed of the carriage must be modified.

The balancing of the model is important, inasmuch as only a small departure in trim near the limit of stability may produce either complete stability or violent porpoising. This fact is particularly true at trims near the upper limit of stability, which are obtained at after positions of the center of gravity.

With up elevator the acceleration should be continued until the model takes off, or with neutral elevator the model should be accelerated to a point well beyond get-away speed. If this acceleration is not continued, porpoising tendencies near get-away, especially at after positions of the center of gravity, will not be detected; the model will appear to be stable, although porpoising or skipping near get-away actually may be present.

Effect of change in gross weight.- Data obtained for several conditions of loading are shown in figures 21 and 22. The amplitude of porpoising at any given horizontal position of the center of gravity generally increases with increase in gross weight, which indicates that the range of stable positions of the center of gravity decreases with increase in gross weight. Summary plots of stable positions for the center of gravity against gross weight (figs. 24(c), 25(b), and 26(b)) show this effect more clearly.

Effect of depth of step.- The results of tests in which the depth of step was varied, the same position of the step being maintained, are plotted in figures 25 and 27. An increase in depth of step from 3.6-percent beam to 6.8-percent beam (fig. 25) produced a maximum shift of less than 3 percent mean aerodynamic chord in the forward limit of the center of gravity. The limit for the deepest step lies between that for the intermediate and shallow step. Figure 27 shows no appreciable change in this limit. The fact that no appreciable or consistent variation with depth of step was obtained indicates that, within the accuracy of these tests, the forward limit for stable positions of the center of gravity was unchanged.

The after limiting position of the center of gravity (fig. 25) was consistently moved forward with increase in depth of step. The maximum change was, however, less than 2 percent mean aerodynamic chord. Figure 27 indicates no definite movement of the limit within the accuracy of the tests. The effect of variation in depth of step on the after limiting position of the center of gravity may therefore be considered as small.

The fact that porpoising at high trim is more easily controlled with the deeper steps does not appear in the data but represents the reactions of the operator controlling the model.

Effect of change in position of step.- The effect of moving the step is shown in figures 24(c) and 26. Moving the position of a 30° Vee step (fig. 24(c)) aft by 0.75 inch (3.1 percent M.A.C.) moved both the forward and after limits for travel of the center of gravity aft by approximately 3 percent mean aerodynamic chord. Moving the 30° Vee step (fig. 26(b)) aft by 1.33 inch (6.4 percent M.A.C.) moved the forward limit approximately 7 percent mean aerodynamic chord in the same direction. The after limit was not obtained for this model, inasmuch as it appeared to be beyond the range for practical operation.

When conventional modifications of the step are used with conventional depths of step, the following conclusions may be drawn. Changing the position of the step changes the forward and after limiting positions for the center of gravity by an approximately equal amount in the same direction. By this method of testing, a position of the step may be determined that will make the hydrodynamic requirements for the position of the center of gravity coincident with the aerodynamic requirements.



Effect of change in plan form of step.— The plan form of the step has been altered for several models. When the plan form of the step is changed, both the effective depth and the effective position of the step are varied. It is therefore desirable to establish some criterion for locating the position of the step when the plan form is changed.

The forward and after limiting positions of the center of gravity of a model with a transverse step, a 20° Vee step, and a 30° Vee step are shown in figures 26(a) and 26(b). The transverse step is located at the midpoint of the altitude of the triangle formed by the 30° Vee step. The 20° and 30° Vee steps coincide at the chine. If it is assumed that the 30° Vee step is the basic step, the following table may be compiled:

Model	Movement of mean, aft		Movement of centroid, aft		Movement of forward limit (percent M.A.C.)	Movement of after limit (percent M.A.C.)	Tested 1941
	(in.)	(percent M.A.C.)	(in.)	(percent M.A.C.)			
D-3	0	0	0	0	0	0	July
D-2	2.16	10	1.87	9	8	5	June
D-1	.81	4	.55	2½	1½	-----	Feb.
D	.81	4	1.28	6	2½	2	Feb.

The agreement between the movement of either the centroid of the step or the mean position of the step and the change in position of the limits for stable positions of the center of gravity is not entirely satisfactory. Predictions made on the basis of the position of the centroid of the step, however, give more nearly the correct position for the limits than predictions made on the basis of the position of the step at the chine, the intersection of the step and the keel, or the mean position of the step. Results of tests of a model with a 30° Vee step and with a transverse step located at the centroid of the 30° Vee step are shown in figure 27. The movement of the limits for travel of the stable positions of the center of gravity was found to be small when the step was changed from a 30° Vee step to a transverse step.

Changing the plan form of the step has a negligible effect on the range of stable positions for the center of gravity within the scope of the modifications tested. There is a possibility that a pointed step similar to that tested in the NACA model 35 series (reference 4) may move the after limit aft without penalizing the forward limit.

Effect of length of afterbody.- The effect of length of afterbody on the limits for stable positions of the center of gravity has not been completely investigated. The length of the afterbody was increased during the tests of two different models. The range of stable positions for the center of gravity was not determined for the first model. It was noted, however, that stability at the design position of the center of gravity was improved by increasing the length of the afterbody from 151-percent beam to 221-percent beam.

The second model had an incipient porpoising motion of small amplitude, which was present at all positions of the center of gravity when a short afterbody with chine flare was used. This porpoising is not consistent with the behavior that has been noted during the tests of other models at either accelerated or constant speed. The violence of this motion increased with movement of the center of gravity either forward or aft of the design positions. The length of the afterbody was increased from 151-percent beam to 195-percent beam and the chine flare was removed from the afterbody. The resulting form had no tendency to porpoise at the design positions of the center of gravity, and the range of stable positions for the center of gravity was definitely increased. Plots of amplitude of porpoising against position of the center of gravity for this model are shown in figure 28.

No definite conclusion as to the effect of increasing the length of the afterbody can be drawn from these data. The results from the test of one model were incomplete. The behavior of the second model was inconsistent with that observed for other models; the improvement noted may have been due to the removal of the chine flare from the afterbody as well as to the increase in the length of the afterbody.

#### LANDING TESTS

The investigation of the longitudinal-stability characteristics of the model is not complete without a

series of landings simulating as nearly as possible full-size maneuvers. The behavior during landing may be quite different from the behavior during take-off. This behavior is analogous to the two upper trim limits of stability at constant speed. A model that is stable during take-off may porpoise violently on landing at high trim. The motion is similar to high-angle porpoising observed at constant speed. This behavior has been noted on full-size flying boats, and the instability has been approximately reproduced with dynamic models. For this reason, a series of landings at various trims is desirable.

The procedure generally followed for these tests consists of: (1) accelerating the model to a speed beyond get-away; (2) trimming the model in the air by means of the elevators to the attitude at which the landing is to be made; and (3) decelerating the carriage, allowing the model to land as flying speed is decreased. This procedure is repeated at trims including both stalling attitudes and low trims, which represent landings at high speeds. The behavior is noted by the observer who is actually controlling the model. His impressions as to the handling characteristics necessarily form an important part of the data. Motion pictures and records of trim and rise permit a detailed study of the motion.

Landings at after positions of the center of gravity are likely to be more unstable than those at forward positions. If the model is unstable in landings at the usual flying positions of the center of gravity, it is likely to be unstable in landing at all practical positions of the center of gravity.

If the model is unstable in landing, a maximum trim can generally be established beyond which skipping occurs. This trim apparently is the same regardless of the position of the center of gravity, indicating that the hydrodynamic forces are the predominant forces contributing to the instability.

One model, having a  $30^\circ$  Vee step with a depth of step of 5.5-percent beam at the keel and 3.2-percent beam at the centroid, had poor landing characteristics. This instability was practically eliminated by increasing the depth of step to 7.2-percent beam at the keel and 4.9-percent beam at the centroid. One other model with a  $30^\circ$  Vee step continued to have a slight landing instability with a depth

of step of 10.5-percent beam at the keel and 8.0-percent beam at the centroid. The landing speeds of this model were very high. Two other models with transverse stops were found to be highly unstable in landing at high trims. These models were improved by increasing the depth of step from 5.0-percent beam to 8.2-percent beam and from 6.5-percent beam to 8.2-percent beam.

Although it is impossible to establish definitely the depth of step necessary to insure stability in landing, it is evident that greater depths than have been generally used on conventional airplanes will be necessary.

The effects of ventilation have already been considered under the results of constant-speed tests. Ventilation definitely has improved the landing characteristics of two models tested in the NACA tank. The amount of ventilation required is greater than has been generally considered necessary for reducing resistance at low speeds. Ventilations should be applied over the center section of the bottom of the model just abaft the step and the ducts should be as close to the keel as possible.

Landing instability of a model having a depth of step of 5.5-percent beam and an angle of afterbody keel of  $5.5^{\circ}$  was not eliminated by decreasing the length of the afterbody from 311-percent beam to 161-percent beam. With a depth of step of 5.5-percent beam and a length of afterbody of 261-percent beam, the landing instability was not eliminated by increasing the angle of afterbody keel from  $4.0^{\circ}$  to  $8.5^{\circ}$ .

The landing characteristics of one model were improved by the use of a pointed step, but the range of stable trims while the model was on the water was greatly reduced.

#### CONCLUDING REMARKS

In order to obtain complete information as to the longitudinal-stability characteristics of a dynamic model of a flying boat as a basis for considering the advantages of modifications, tests should be made (1) at constant speeds, to determine the trim limits of stability; (2) at accelerated speeds, to locate the position of the step and

observe take-off characteristics; and (3) at decelerated speeds, to simulate landings and observe skipping characteristics.

Until more data are available and further refinements are made in the methods of obtaining this data, the following conclusions are offered as a guide for future tests and designs.

1. Increasing the gross weight raises all the trim limits of stability and narrows the range of stable positions of the center of gravity. The forward limit for travel of the center of gravity is moved aft and the after limit is moved forward.

2. Changing the fore-and-aft position of the center of gravity does not appreciably change the trim limits of stability. The hydrodynamic trimming moments become more negative as the center of gravity moves forward, increasing the possibility of encountering lower-limit porpoising during take-off. The hydrodynamic trimming moments become more positive as the center of gravity is moved aft, and upper-limit porpoising is more likely to occur. Landings are more likely to be unstable with the center of gravity in the after positions than in the forward positions.

3. Increasing the depth of step has a negligible effect on the lower trim limit of stability but the upper trim limits of stability are raised. Changes in the depth of step have an indefinite effect on the forward limit for stable positions of the center of gravity; an increase causes the after limit to be moved forward by a negligible amount. The instabilities appearing in landing are reduced or eliminated by increased depth of step. In models depths of step of the order of 8 percent of the beam are necessary to eliminate skipping tendencies present in landings at high trims.

4. Changing the position of the step has no effect on the lower limit of stability. The upper limits appear to be raised slightly as the step is moved aft. The change in the hydrodynamic trimming moment, and therefore the range of available trims, is more important than the change in trim limits of stability. Changing the position of the step shifts the range of stable positions of the center of gravity approximately the same distance and in the same direction that the step is shifted,

5. Altering the plan form of the step has a negligible effect on the lower limit of stability. The upper limits are probably changed as the effective depth of step is increased or decreased. The range of stable positions of the center of gravity is shifted a distance approximately equal to the change in the position of the centroid of the step.

6. Ventilation of a shallow step does not change the lower trim limit of stability but raises the upper trim limits. Ventilation reduces the tendency to increase trim on take-off and reduces landing instability. Ventilation is more effective when applied near the keel than at the chines. Larger ventilation ducts are required than have been considered necessary for reducing the resistance at low speeds.

7. Varying the length of the afterbody has a negligible effect on the lower trim limit of stability. The upper limits are raised as the afterbody length is decreased. The available information indicates that stability during take-off is increased by lengthening the afterbody. The range of stable positions for the center of gravity of one model was increased when the length of afterbody was increased from 151-percent to 195-percent beam. In these tests not only was the length of afterbody increased but the chine flare on the afterbody was removed. With a depth of step of 5.5-percent beam and an angle of afterbody keel of  $5.5^{\circ}$ , instability in landing was present for lengths of afterbody from 161 to 311 percent of the beam.

8. Changing the angle of afterbody keel has no definite effect on the lower trim limit of stability. The upper trim limits are raised as the angle of afterbody keel is increased. With a depth of step of 5.5-percent beam and an afterbody length of 261-percent beam, instability in landing was present for angles of afterbody keel from  $4.0^{\circ}$  to  $8.5^{\circ}$ .

9. Decreasing the angle of dead rise of a planing surface decreases the lower trim limit of stability.

10. The addition of a pointed step decreases the range of stable trims between the upper and lower trim limits of stability. The lower trim limit, at intermediate planing speeds, is raised when the transverse step is replaced by a pointed step. No instability was

present during landings at high trims, but the possibility of porpoising during the deceleration while the model is on the water is great.

Langley Memorial Aeronautical Laboratory,  
National Advisory Committee for Aeronautics,  
Langley Field, Va.

#### REFERENCES

1. Olson, Roland E. and Land, Norman S.: The Longitudinal Stability of Flying Boats as Determined by Tests of Models in the NACA Tank. I - Methods Used for the Investigation of Longitudinal-Stability Characteristics. NACA A.R.R., Nov. 1942.
2. Benson, James M.: The Porpoising Characteristics of a Planing Surface Representing the Forebody of a Flying-Boat Hull. NACA A.R.R., May 1942.
3. Benson, James M., and Lina, Lindsay J.: The Effect of Dead Rise upon the Low-Angle Type of Porpoising. NACA A.R.R., Oct. 1942.
4. Dawson, John E.: Tank Tests of Three Models of Flying-Boat Hulls of the Pointed-Step Type with Different Angles of Dead Rise - N.A.C.A. Model 35 Series. T. N. No. 551, NACA, 1936.
5. Stout, Ernest G.: Experimental Determination of Hydrodynamic Stability. Jour. Aero. Sci., vol. 8, no. 2, Dec. 1940, pp. 55-61.

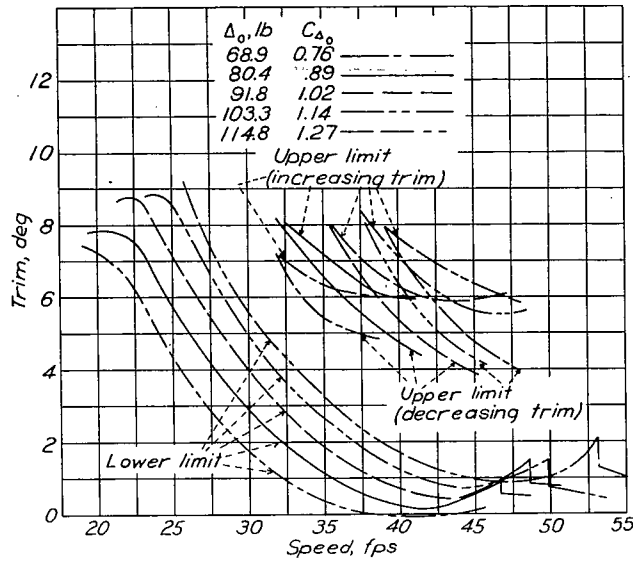

Figure 1.- Effect of gross weight on trim limits of stability. Model 1, 1/12 full-size.

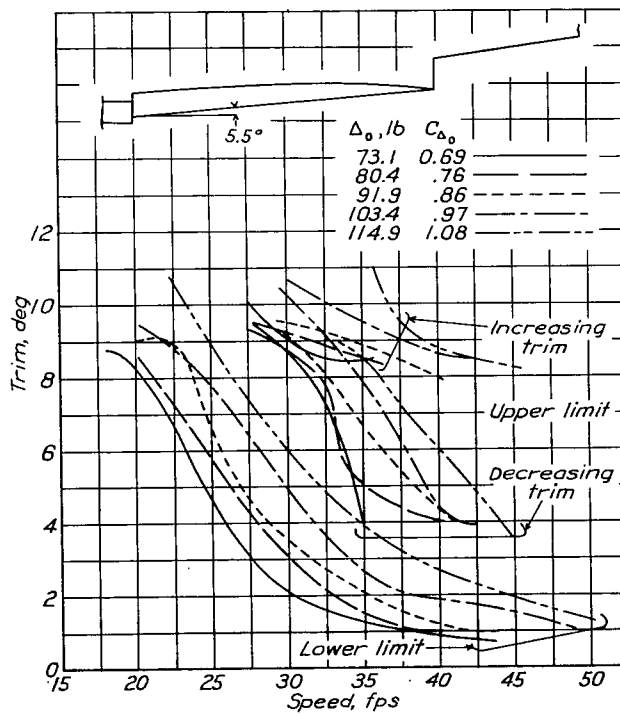

Figure 3.- Effect of gross weight on trim limits of stability. Model 3, 1/12 full-size.



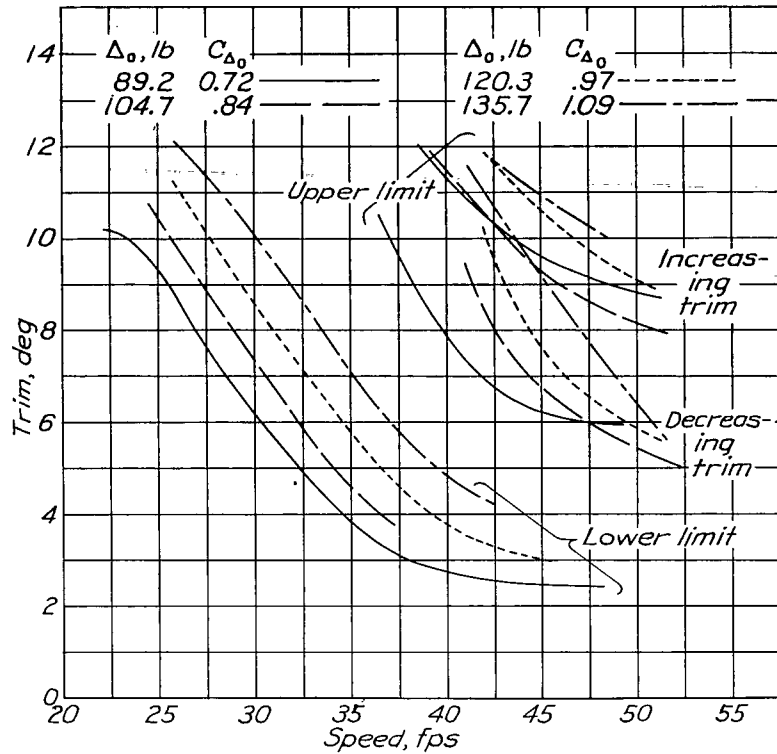

Figure 2.- Effect of gross weight on trim limits of stability. Model 2, 1/8 full-size.

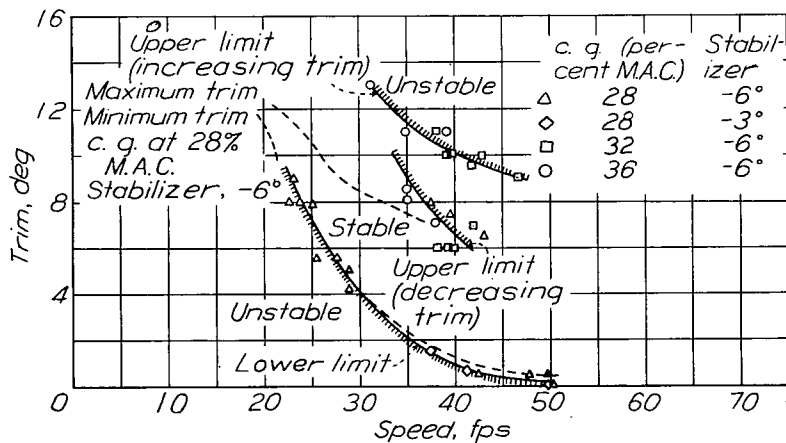

Figure 4.- Effect of position of center of gravity on the trim limits of stability. Model 4, 1/10 full-size.  $\Delta_0, 128 lb$ ;  $C_{\Delta_0}, 0.89$ .

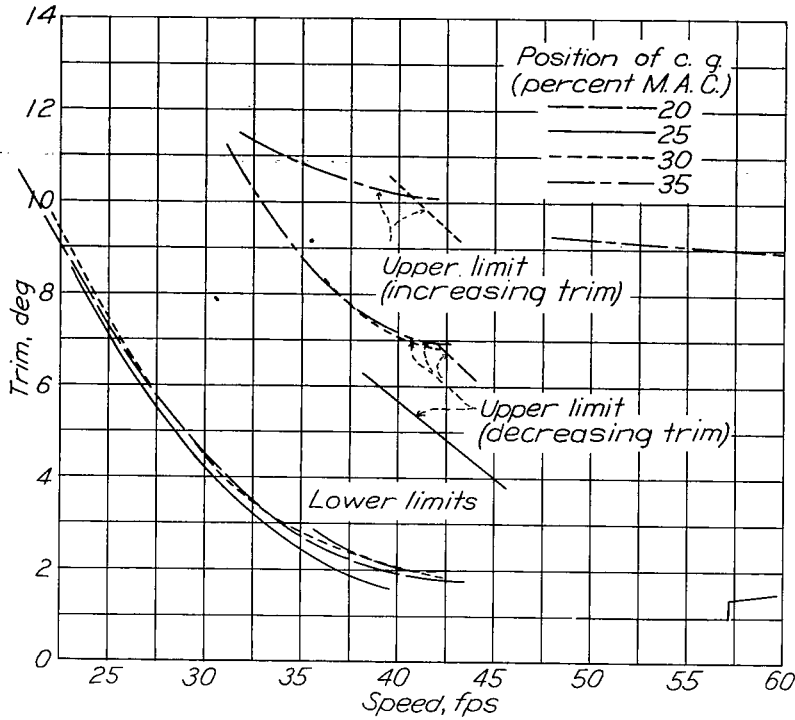

Figure 5.- Effect of position of the center of gravity on the trim limits of stability. Model 5, 1/10 full-size.  $\Delta_0$ , 61.5 lb;  $C_{\Delta_0}$ , 0.86.

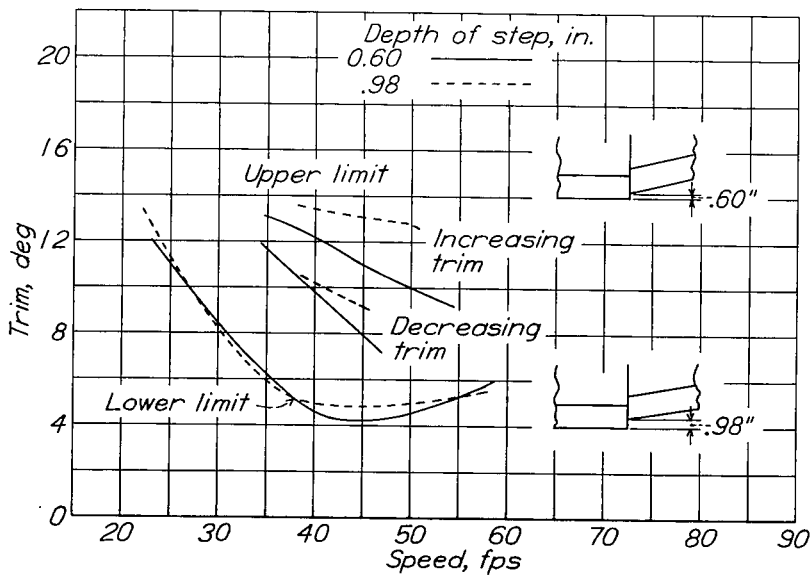

Figure 7.- Effect of depth of step on trim limits of stability. Model 6, 1/5 full-size.  $\Delta_0$ , 63.4 lb;  $C_{\Delta_0}$ , 1.01.

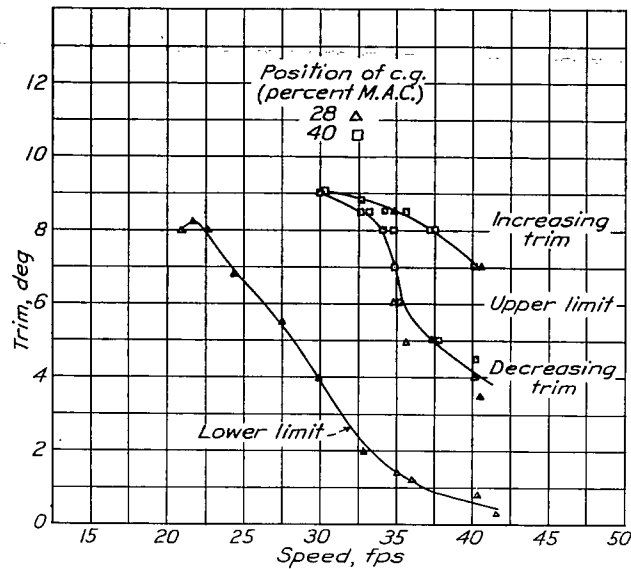

Figure 6.- Effect of position of the center of gravity on trim limits of stability. Model 7.  $\Delta_0$ , 91.9 lb;  $C_{\Delta_0}$ , 0.86. Scale, 1/12 full size.

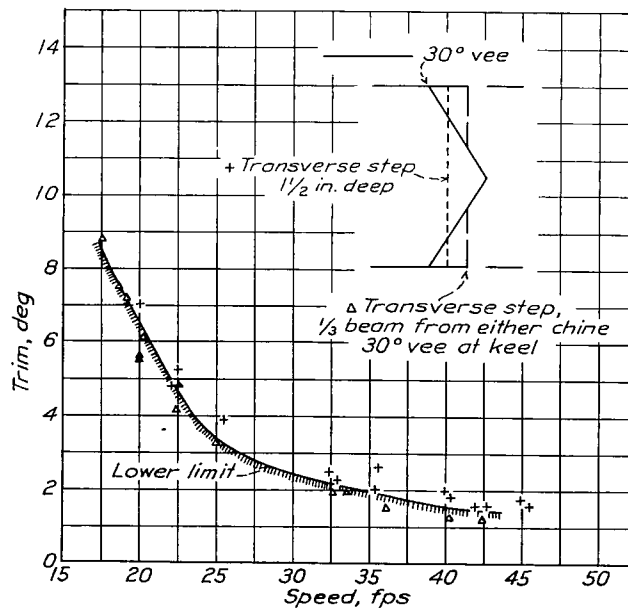

Figure 13.- Effect of plan form on lower limit of stability. Model 8.  $\Delta_0$ , 53.8 lb;  $C_{\Delta_0}$ , 0.41. Scale, 1/8 full-size.

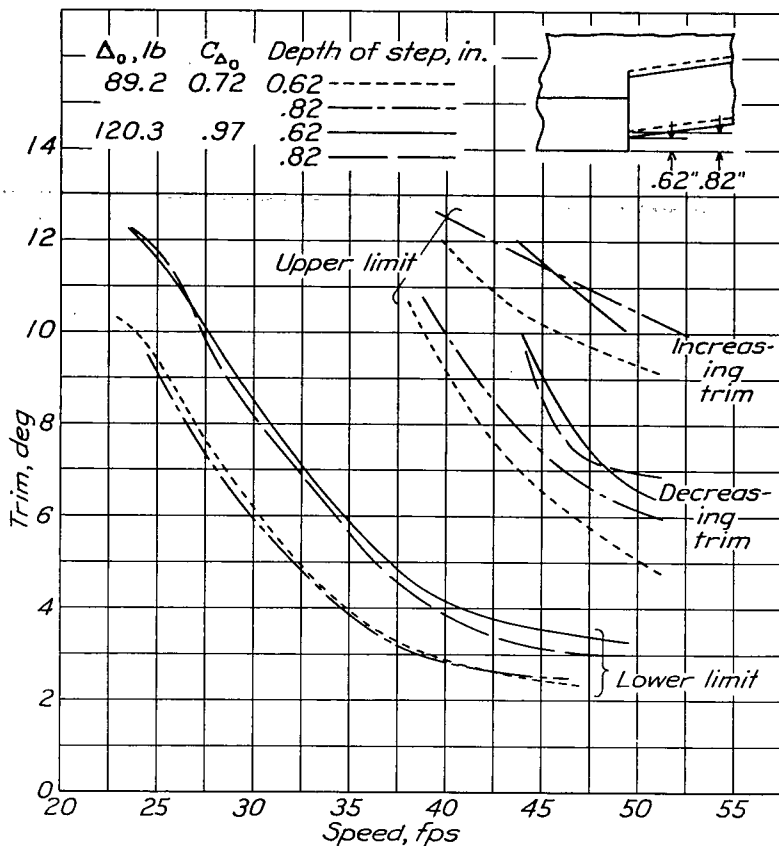

Figure 8.- Effect of depth of step on trim limits of stability. Model 2, 1/8 full-size.

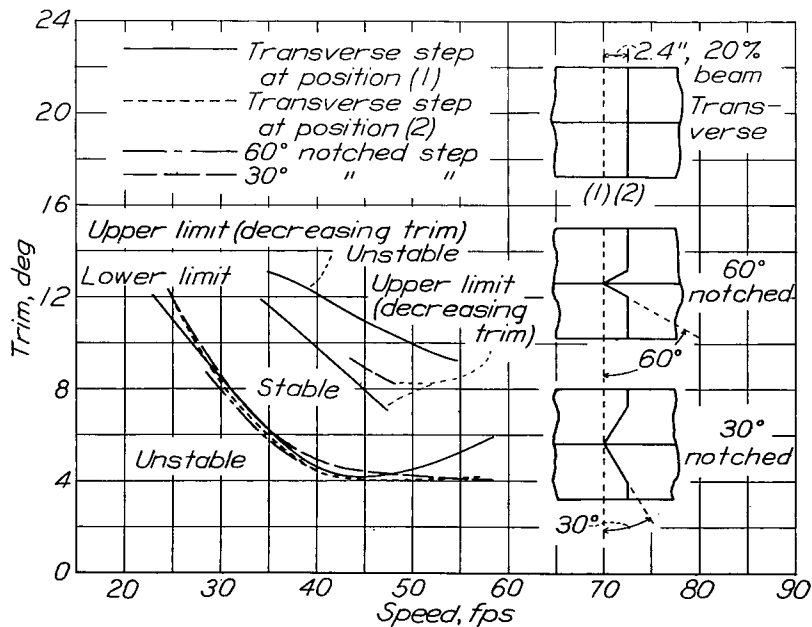

Figure 10.- Effect of position and plan form of step on trim limits of stability. Model 6, 1/5 full-size.  $\Delta_0$ , 63.4 lb;  $C_{\Delta_0}$ , 1.01.

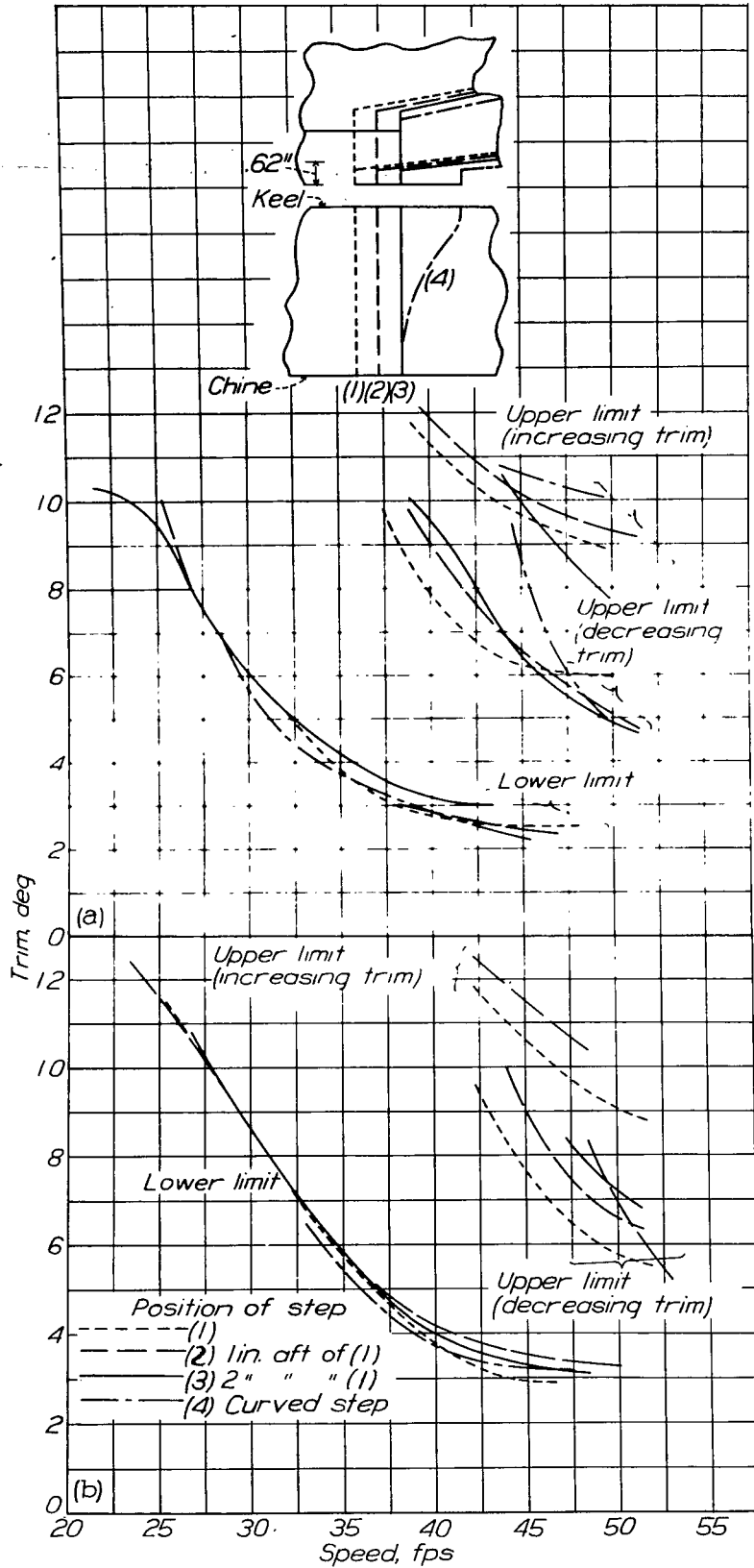

Figure 9.-  
Effect of  
position  
and plan  
form of  
step on  
trim  
limits  
of  
stability.  
Model 2,  
1/8 full-  
size.

(a)  $\Delta_0$ , 89.2 lb

$C_{\Delta_0}$ , 0.72

(b)  $\Delta_0$ , 120.3 lb

$C_{\Delta_0}$ , 0.97

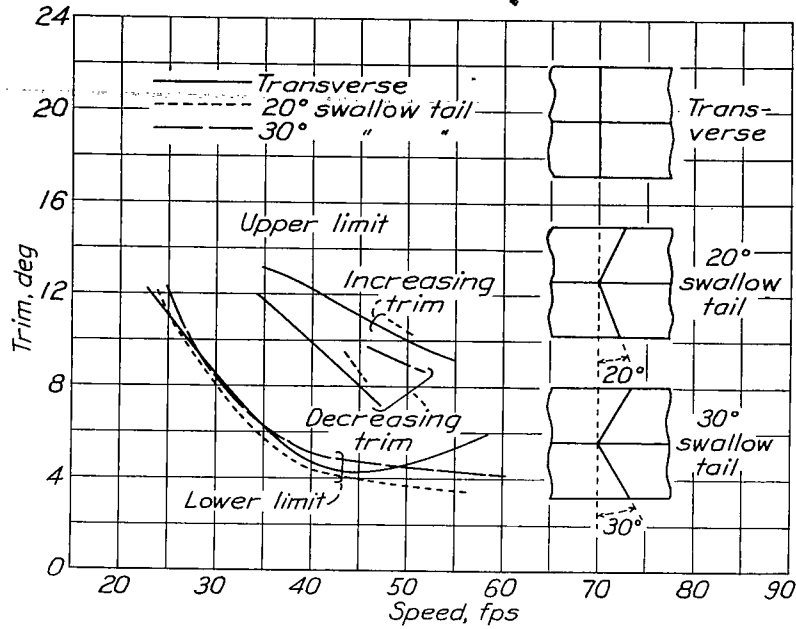

Figure 11.- Effect of plan form of step on trim limits of stability. Model 6, 1/5 full-size.  $\Delta_0$ , 63.4 lb;  $C_{\Delta_0}$ , 1.01.

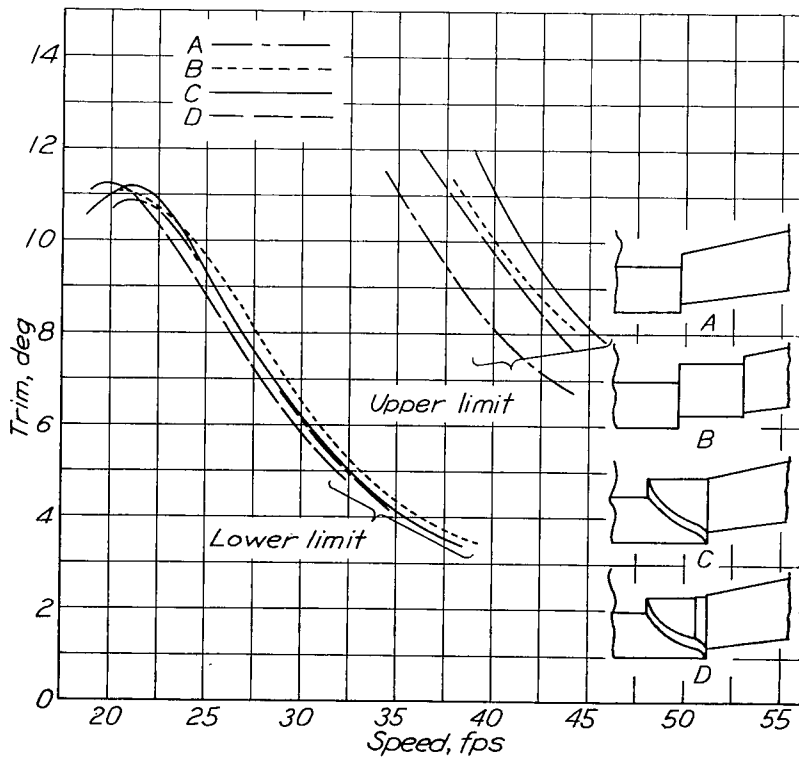

Figure 12.- Effect of plan form of step on trim limits of stability. Model 7, 1/8 full-size.  $\Delta_0$ , 76.2 lb;  $C_{\Delta_0}$ , 1.0.

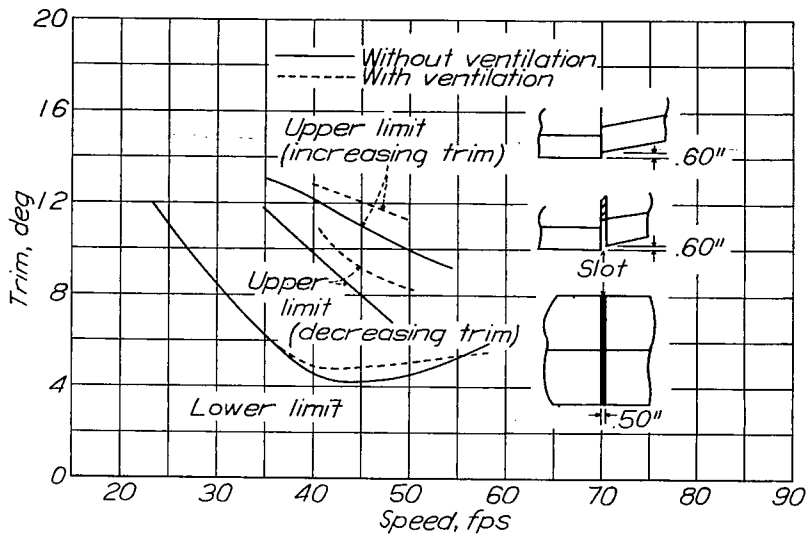

Figure 14.- Effect of ventilation on trim limits of stability. Model 6, 1/5 full-size.  $\Delta_0$ , 63.4 lb;  $C_{\Delta_0}$ , 1.01.

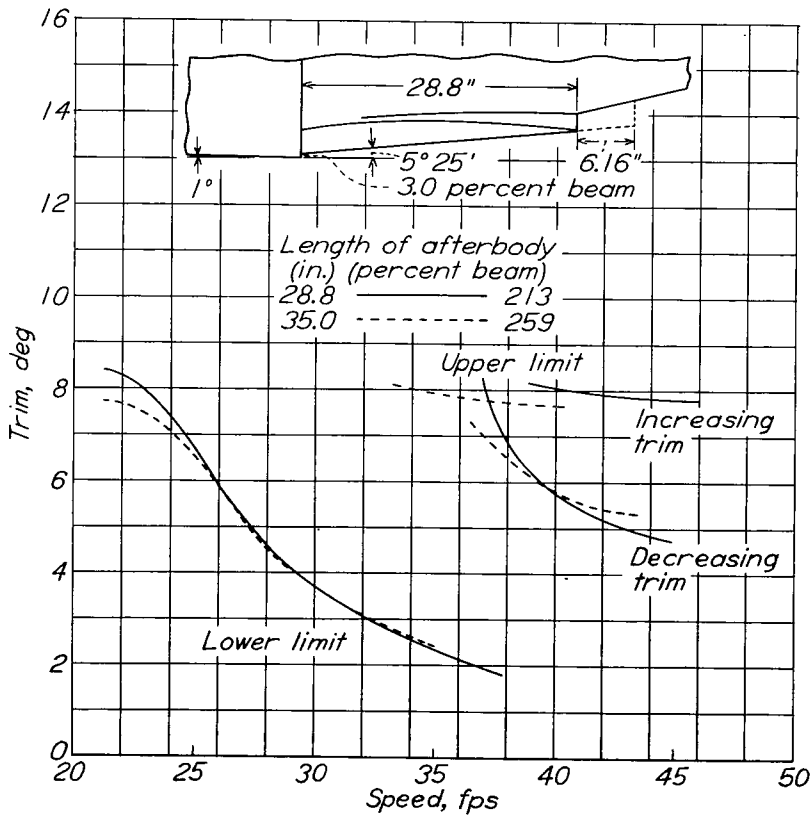

Figure 17.- Effect of afterbody length on trim limits of stability. Model 9, 9/100 full-size.  $\Delta_0$ , 60.8 lb;  $C_{\Delta_0}$ , 0.67.

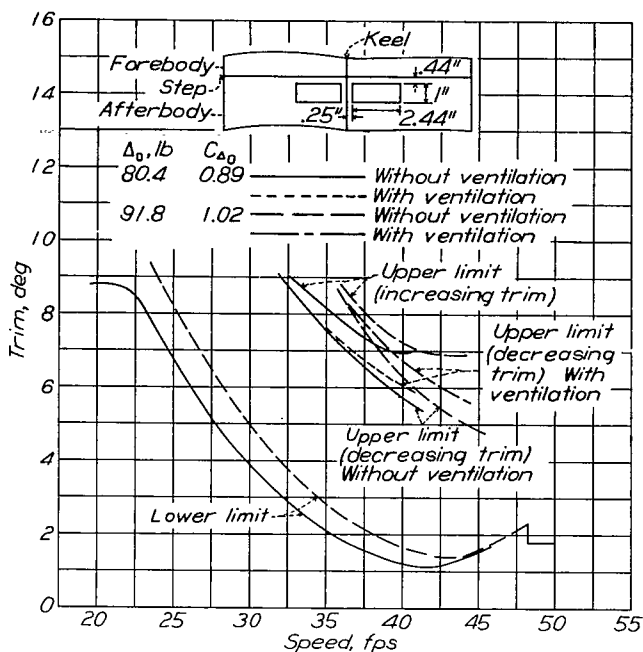
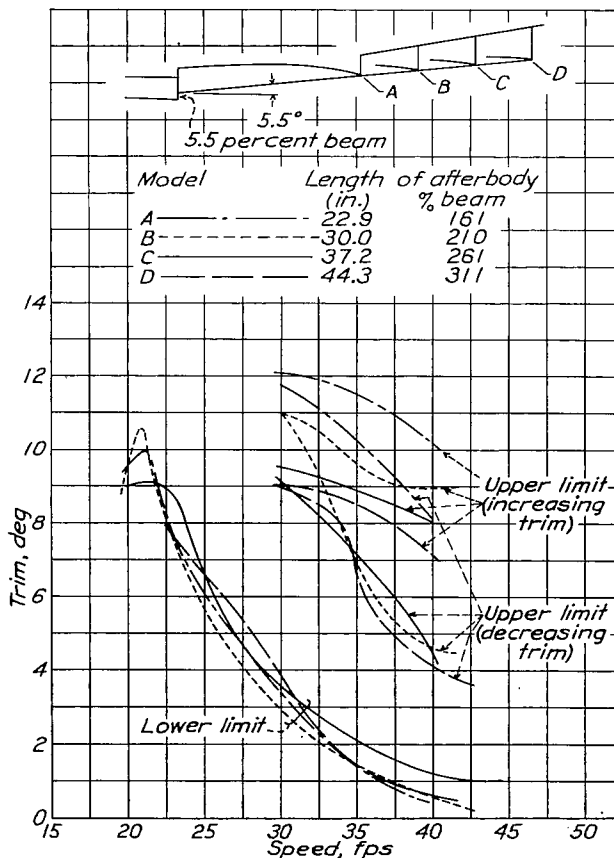

Figure 15.- Effect of ventilation on upper trim limits of stability. Model 1. 1/12 full-size

Figure 16.- Effect of afterbody length on trim limits of stability. Model 3.  $\Delta_0$ , 91.9 lb;  $C_{\Delta_0}$ , 0.86 Scale, 1/12 full-size.





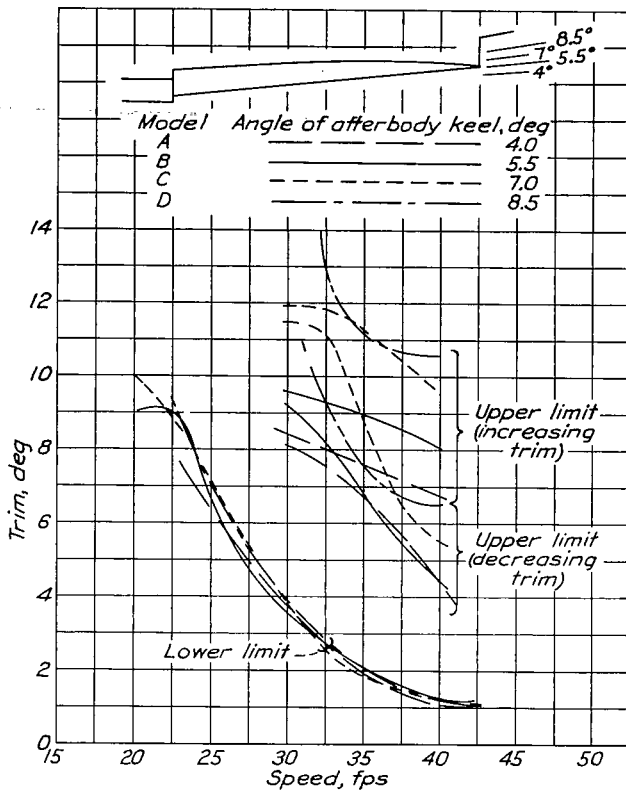
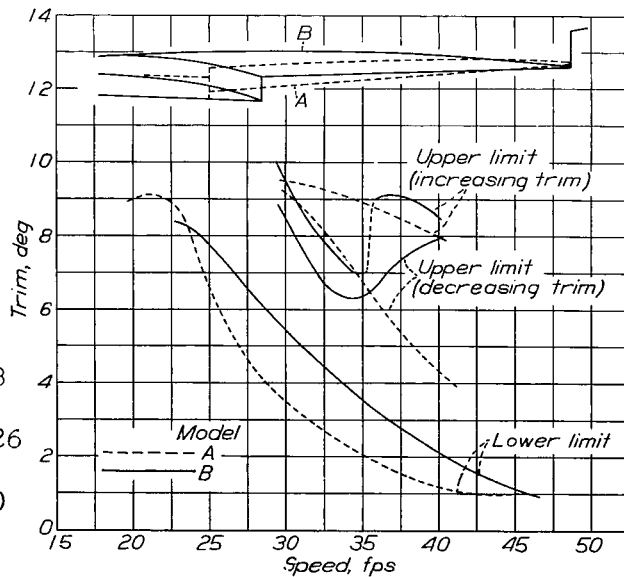
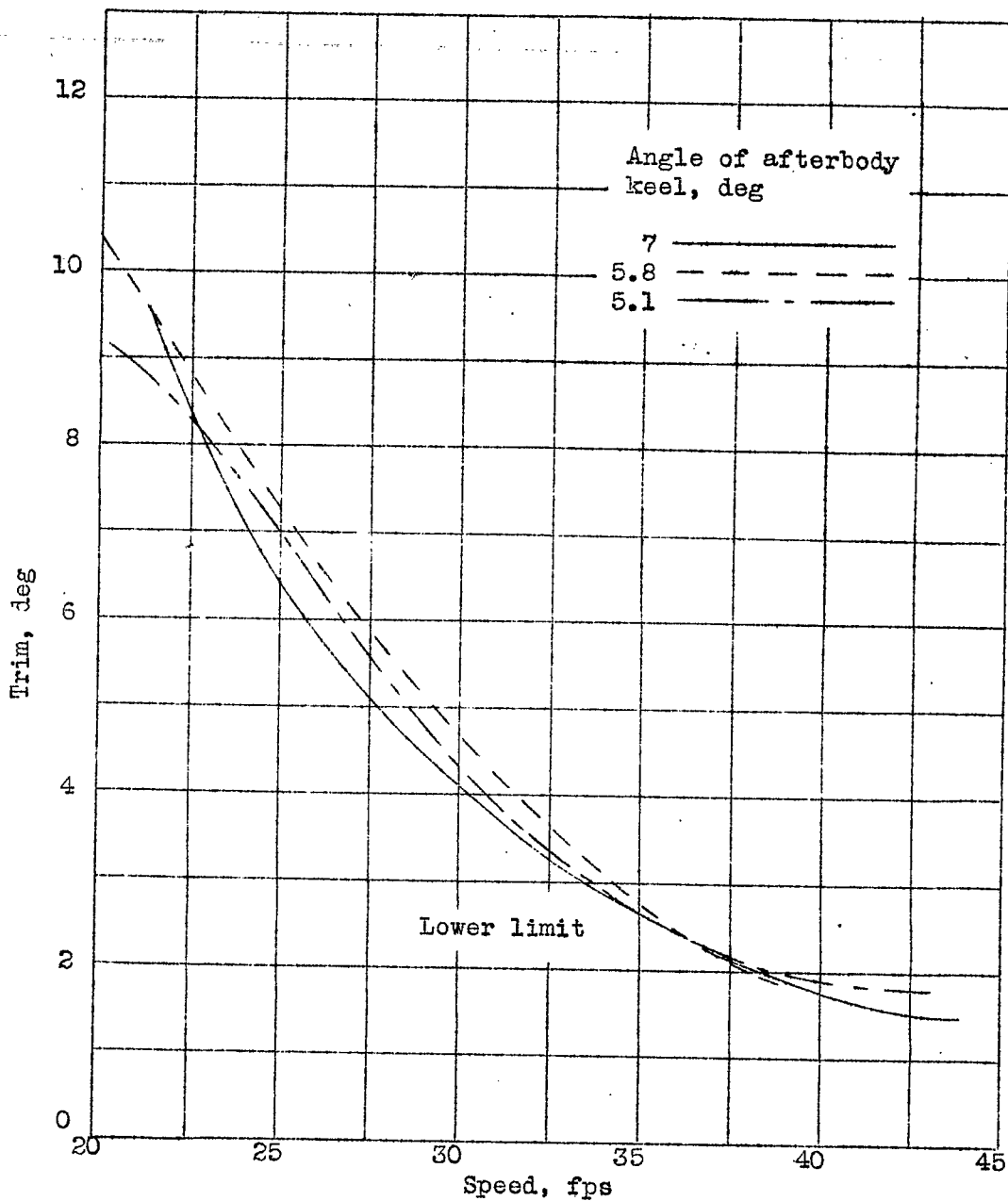

Figure 18.- Effect of increasing the angle of afterbody keel on trim limits of stability. Model 3.  $\Delta_0$ , 91.9 lb;  $C_{\Delta_0}$ , 0.86. Length of afterbody beam = 2.61. Scale, 1/12 full size.

Figure 20.- Effect of pointed step on trim limits of stability. Model 3.  $\Delta_0$ , 91.9 lb;  $C_{\Delta_0}$ , 0.86. Scale, 1/12 full size.

Model	A	B
Depth of step at keel, % beam	5.5	15.8
Length of afterbody beam	2.61	2.26
Angle of keel, deg	5.5	2.0





$\Delta_0, 61.5 \text{ lb}; C_{\Delta_0}, 0.86$

Figure 19.- Effect of angle of afterbody keel on trim limits of stability. Model 5, 1/10 full-size.

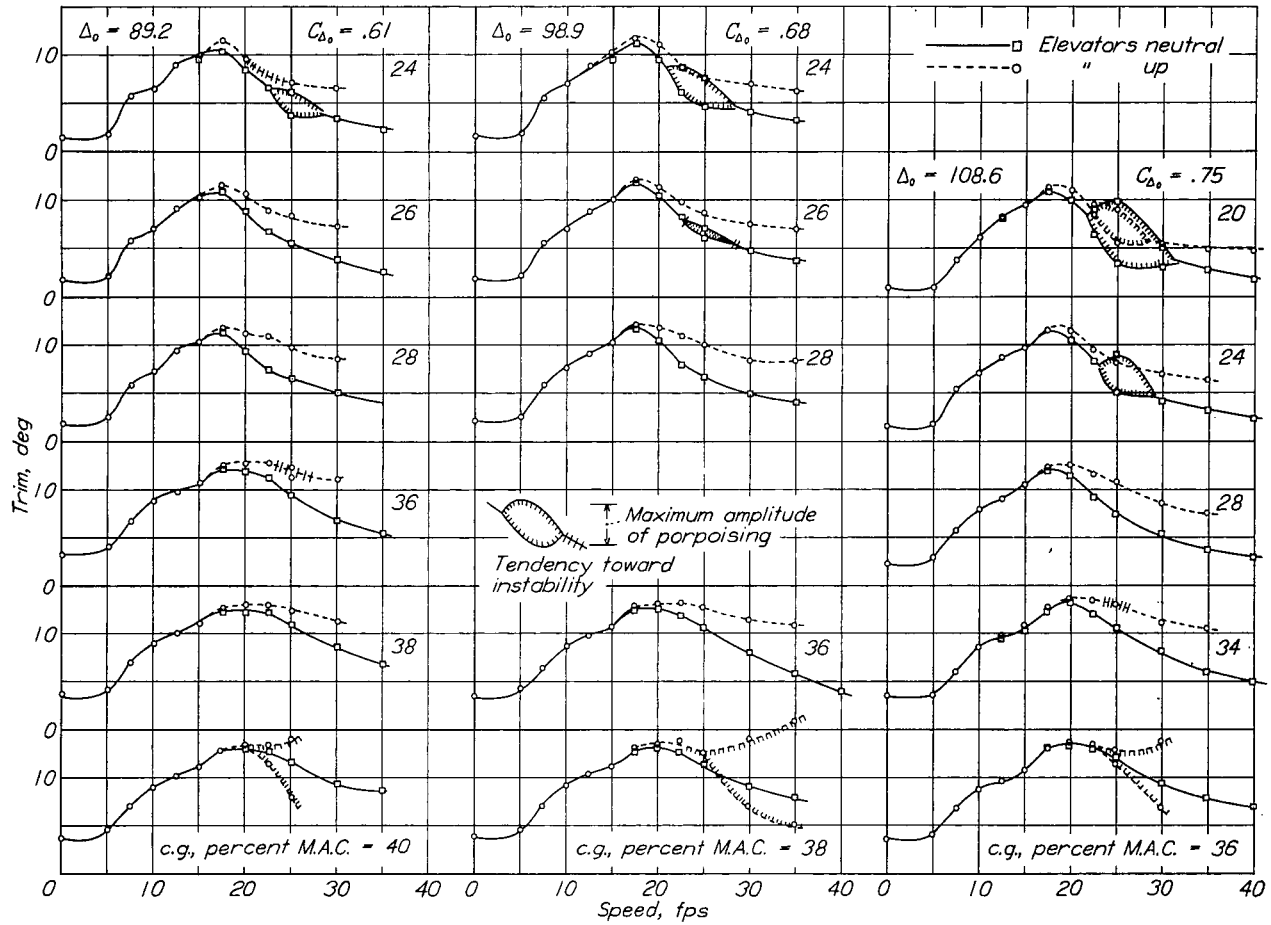

Figure 21.- Effect of position of center of gravity and gross weight on trim. Model 10, 1/8 full-size.

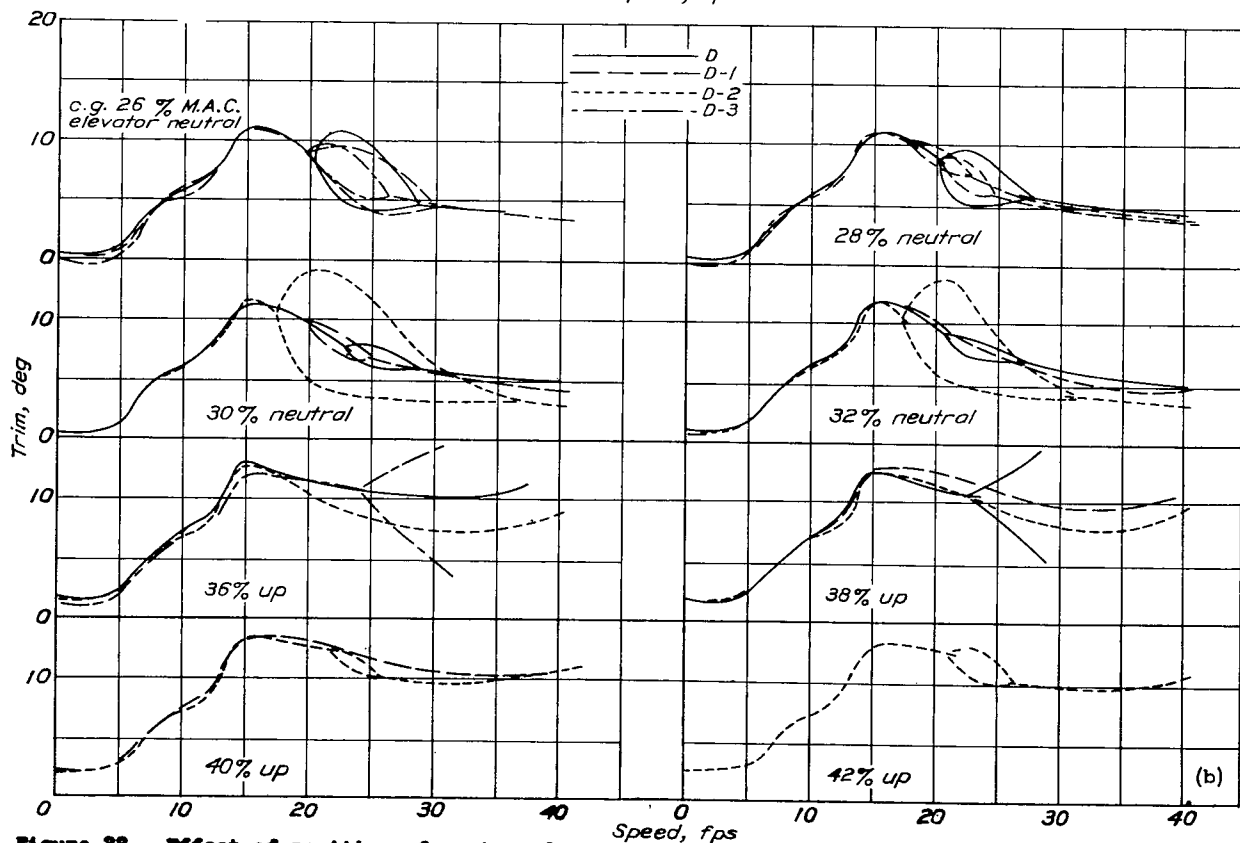
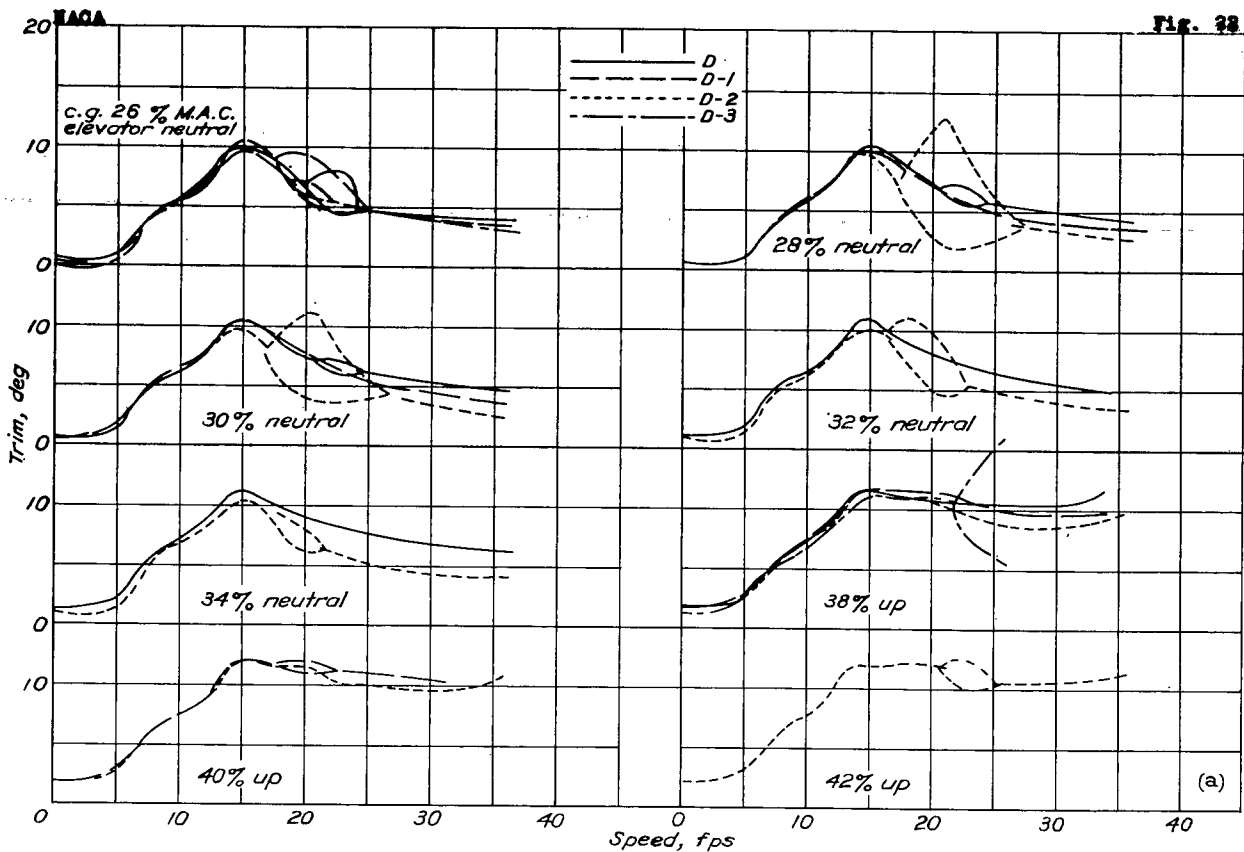
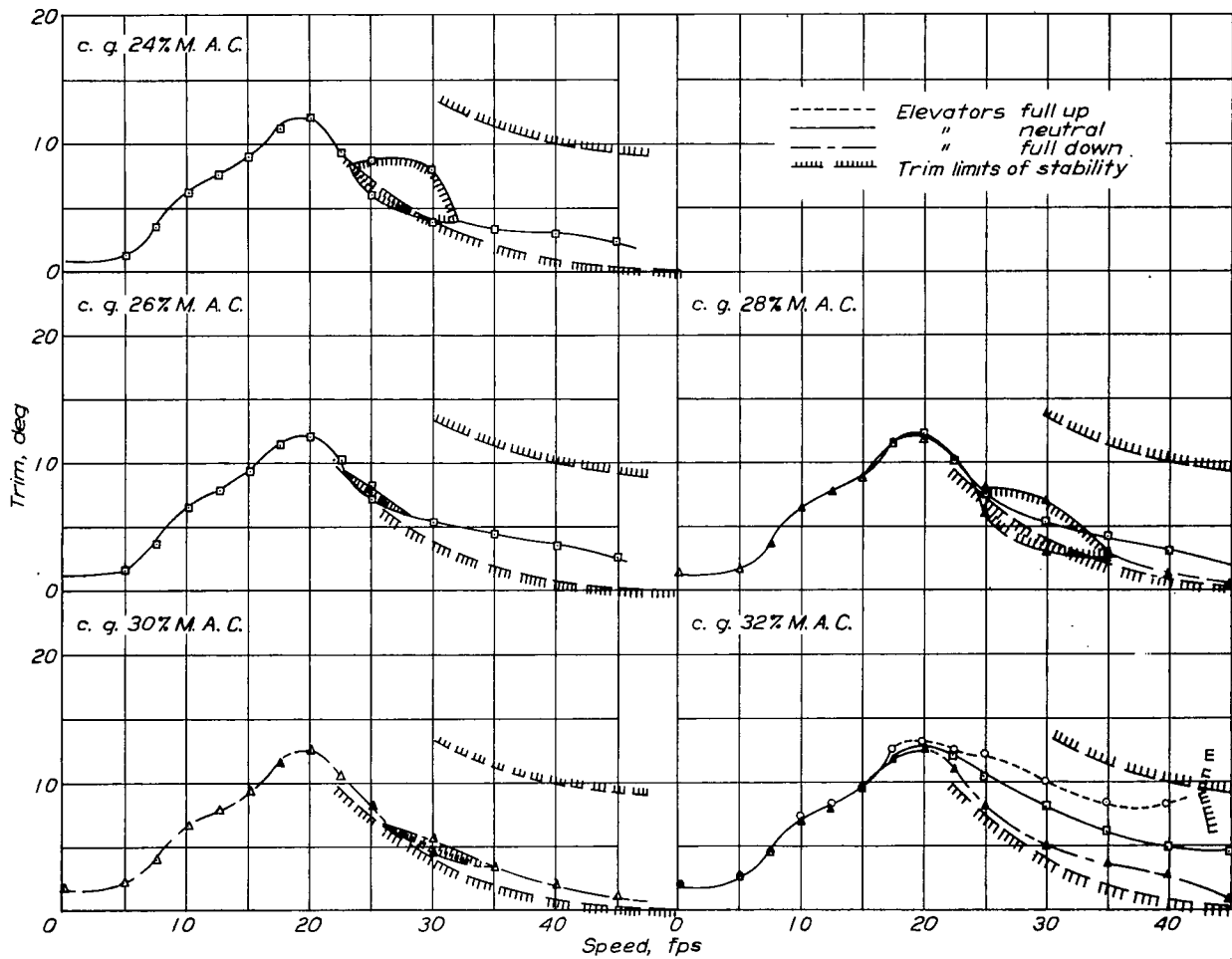

Figure 28.- Effect of position of center of gravity and location of step on trim. Model 11, 1/8 full-size. For sketch see figure 26-b. (a)  $\Delta_0$ , 58.8;  $C_{A_0}$ , .44. (b)  $\Delta_0$ , 77.5;  $C_{A_0}$ , .59.



Scale, 1/8 full-size.

Figure 23.- Relation of porpoising during accelerated runs with trim limits of stability, Model 12.

$\Delta_0$ , 128 lb;  $C_{\Delta_0}$ , 0.89

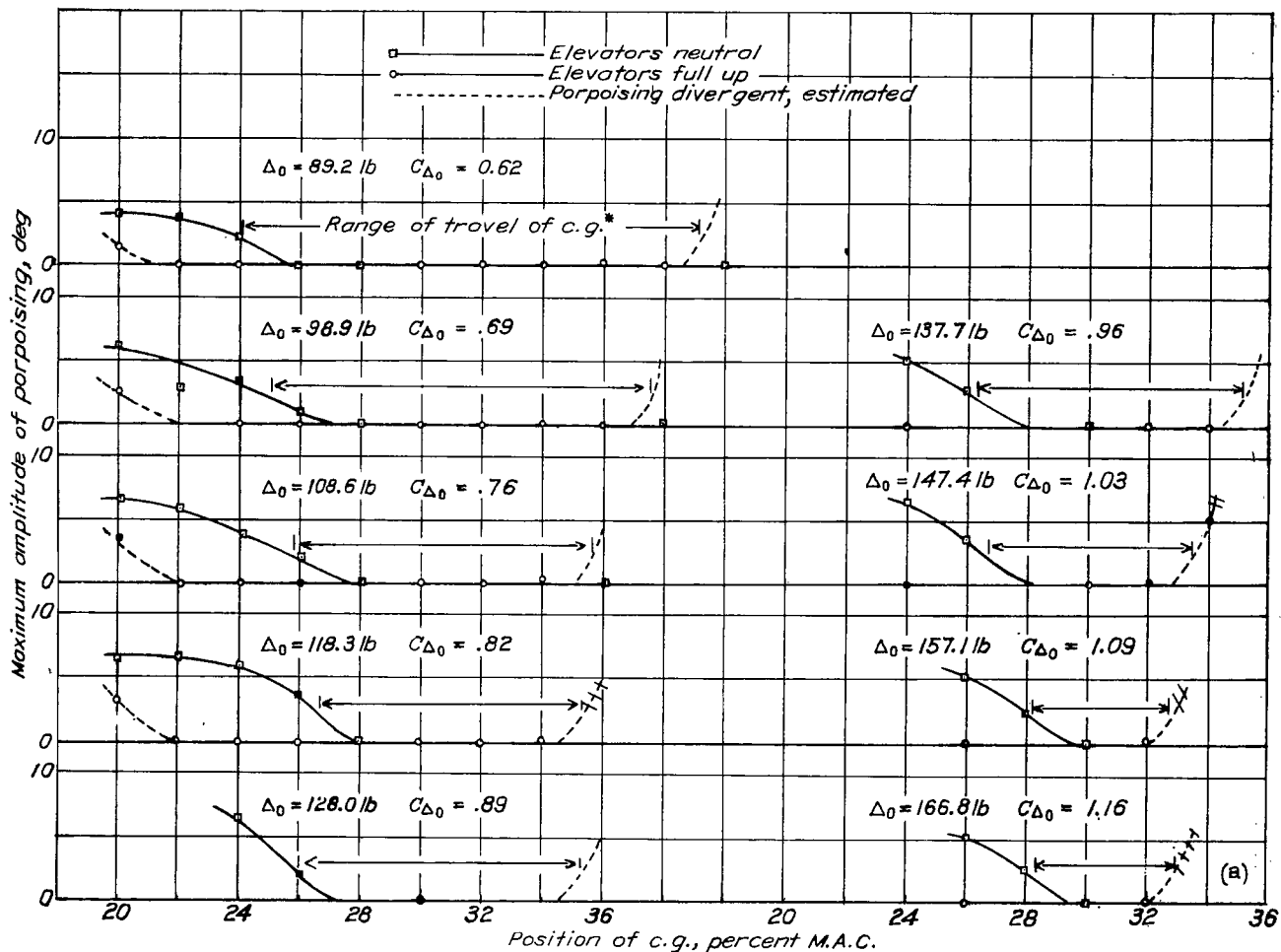

(a) On amplitude of porpoising. Model 13. Scale, 1/8 full-size.

\* Assuming 3° as the limiting amplitude of porpoising.

Figure 24.- Effect of gross weight.

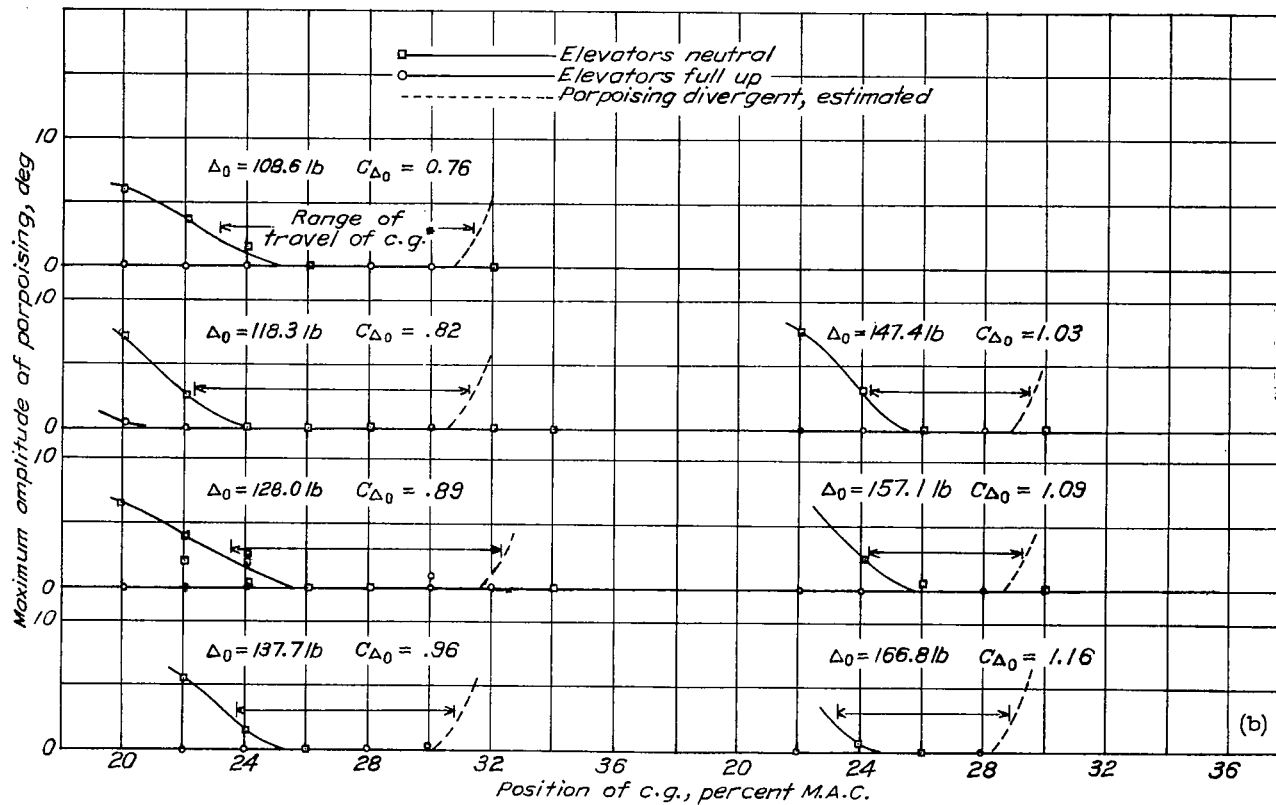

(b) On amplitude of porpoising. Model 14. Scale, 1/8 full-size.

\* Assuming  $2^\circ$  as the limiting amplitude of porpoising.

Figure 24.- Effect of gross weight.

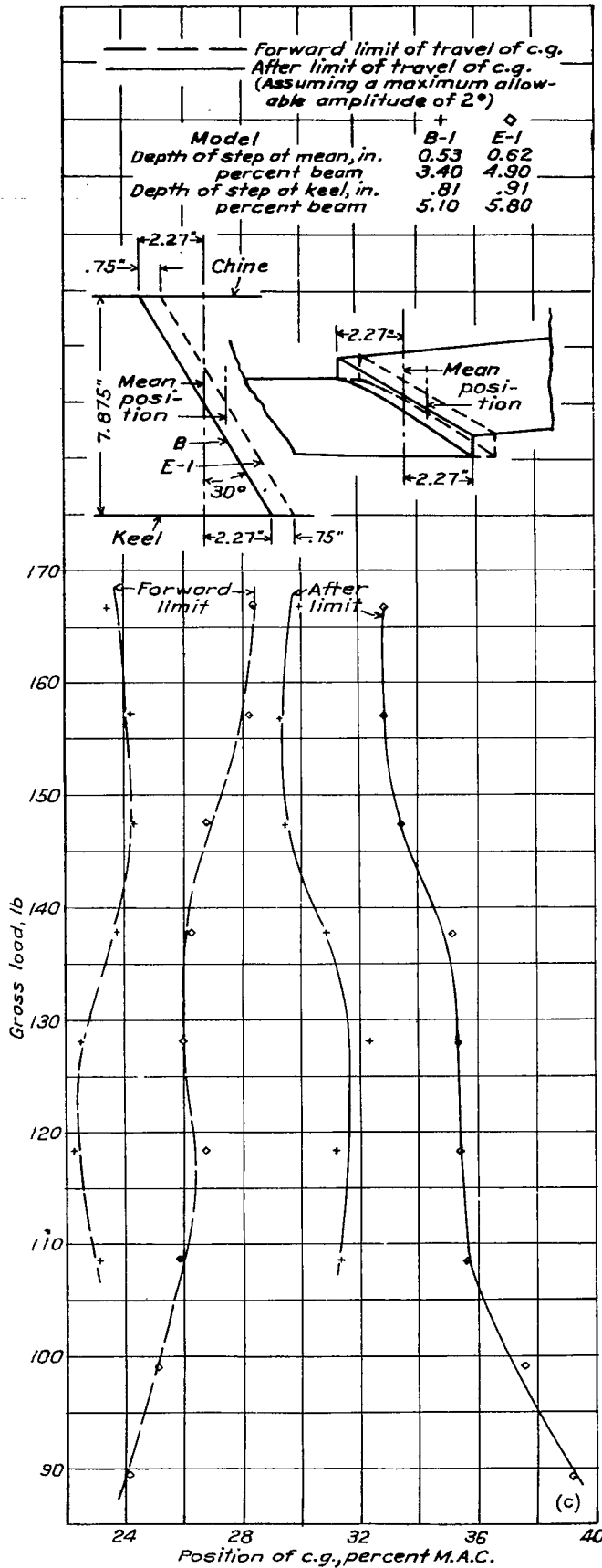

(c) On limits for stable positions of the center of gravity. Models 13 and 14, 1/8 full-size.

Length of M.A.C. 24.3 in.

Figure 24c.- Effect of gross weight. (Concluded.)



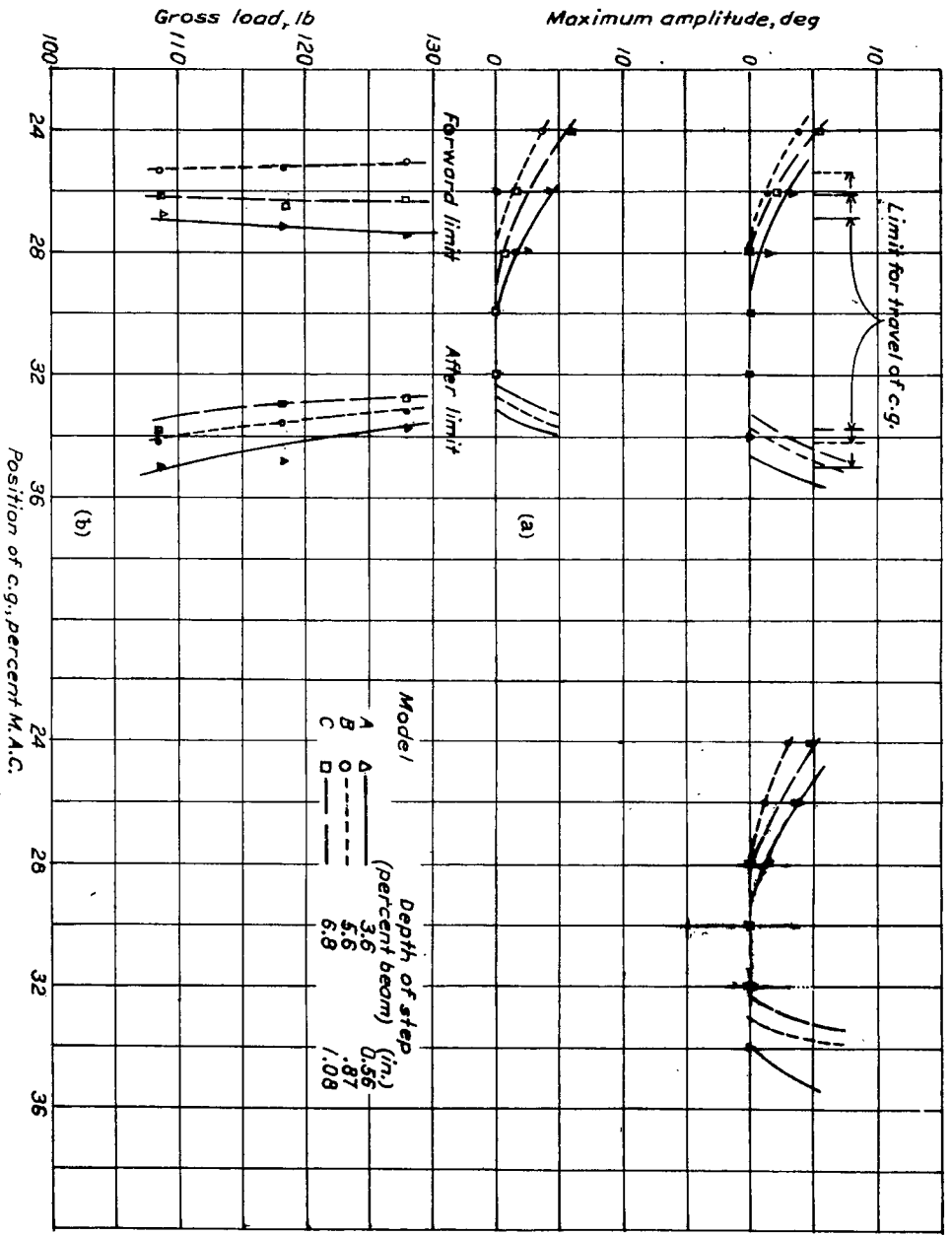

(a) On maximum amplitude of perpoising. Elevators neutral at forward positions of c. g. Elevators full up at after positions of c. g.

(b) On limits for travel of the center of gravity. Forward limit of travel of c. g. After limit of travel of c. g. (maximum permissible amplitude, 20). Length of M. A. C., 24.3 in.

Figure 25.- Effect of depth of step. Model 15.  $A_0$ , 128 lb.,  $C_{D_0}$ , 0.89.

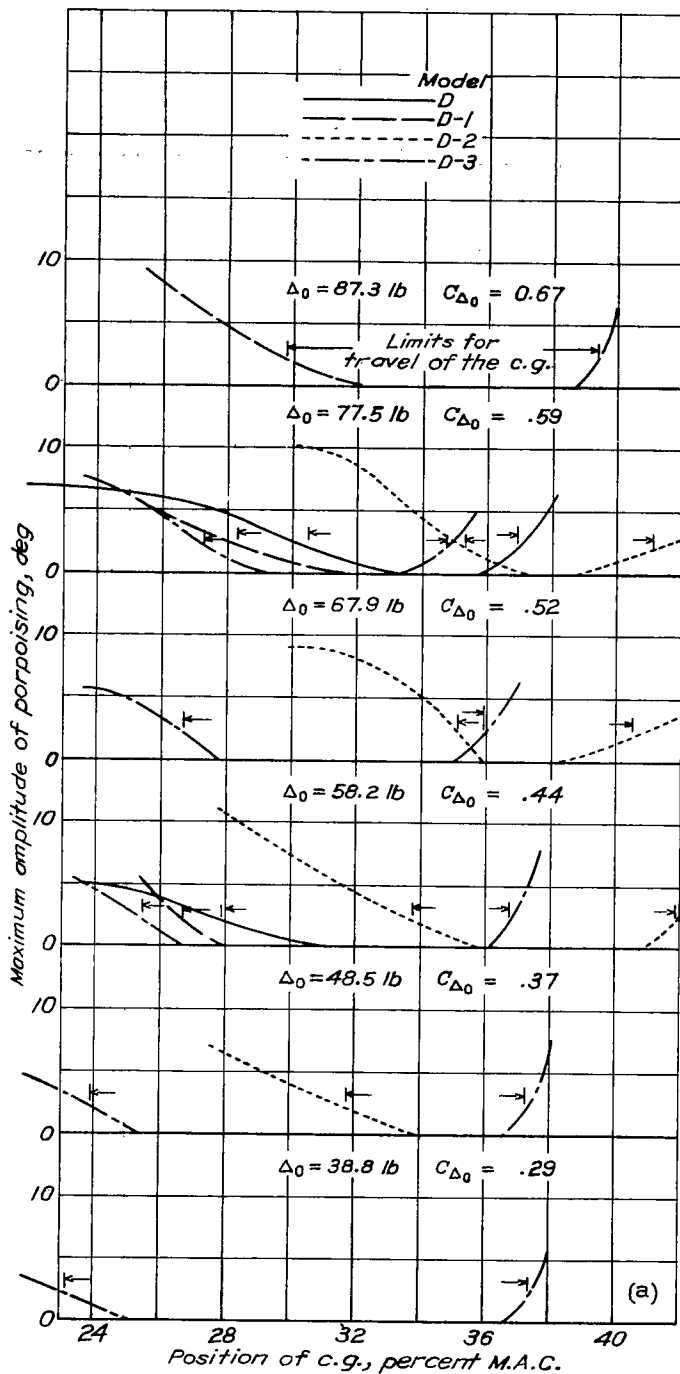

(a) On maximum amplitude of porpoising.  
 Elevators neutral at forward positions of c.g.  
 Elevators up at after positions of c.g.

Figure 26.- Effect of position of step and gross weight. Model 11, 1/8 full size. For sketch see figure 26b.

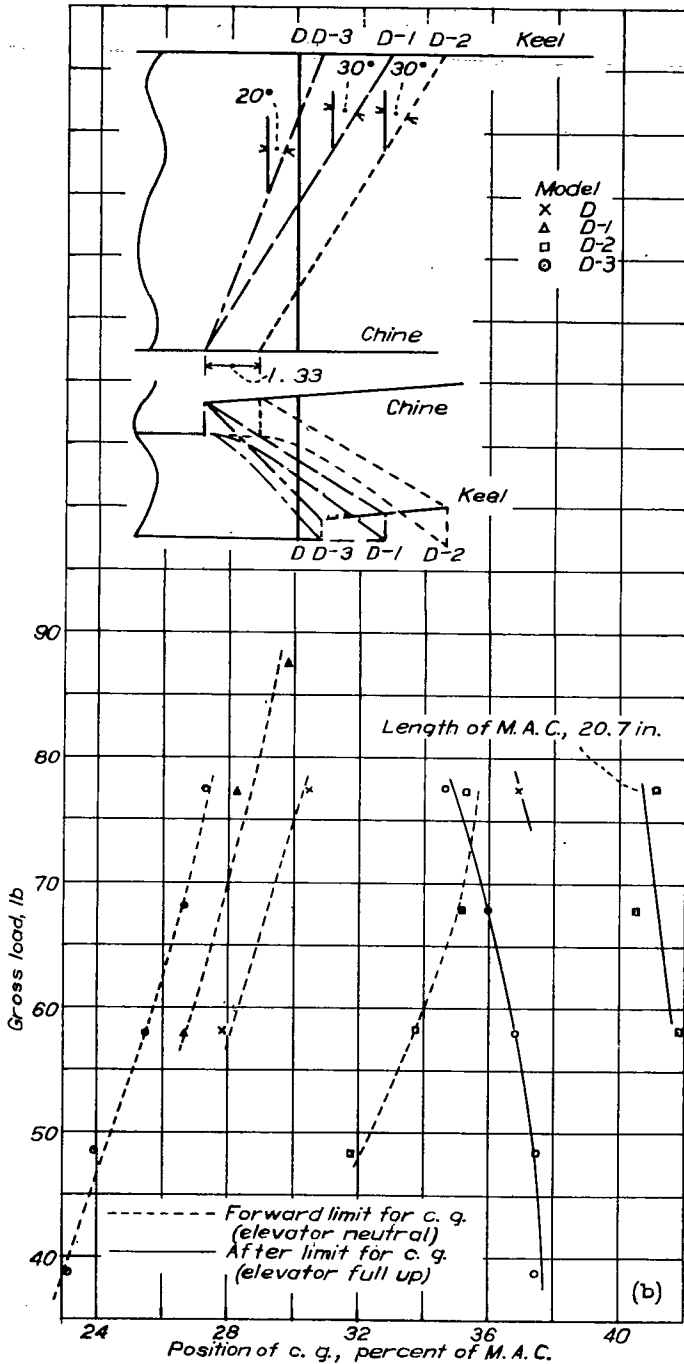

Model	D	D-1	D-2	D-3
Location from transverse step, in.				
Chine for'd	0	2.209	0.875	2.209
Keel aft	0	2.209	3.541	.575
Depth of step				
At chine, in.	.51	.75	.93	.75
At keel, in.	.51	.79	.97	.59
At mean, in.	.51	.51	.68	.41
Depth of step, percent beam				
At chine	3.33	4.90	6.08	4.90
At keel	3.33	5.16	6.34	3.86
At mean	3.33	3.33	4.44	2.68
Tested.	1941 Feb.	Feb.	June	July

(Assuming a maximum allowable amplitude of 20°.)

Scale, 1/8 full size.

(b) On limits for stable positions of the center of gravity.

Figure 26. (Concluded).

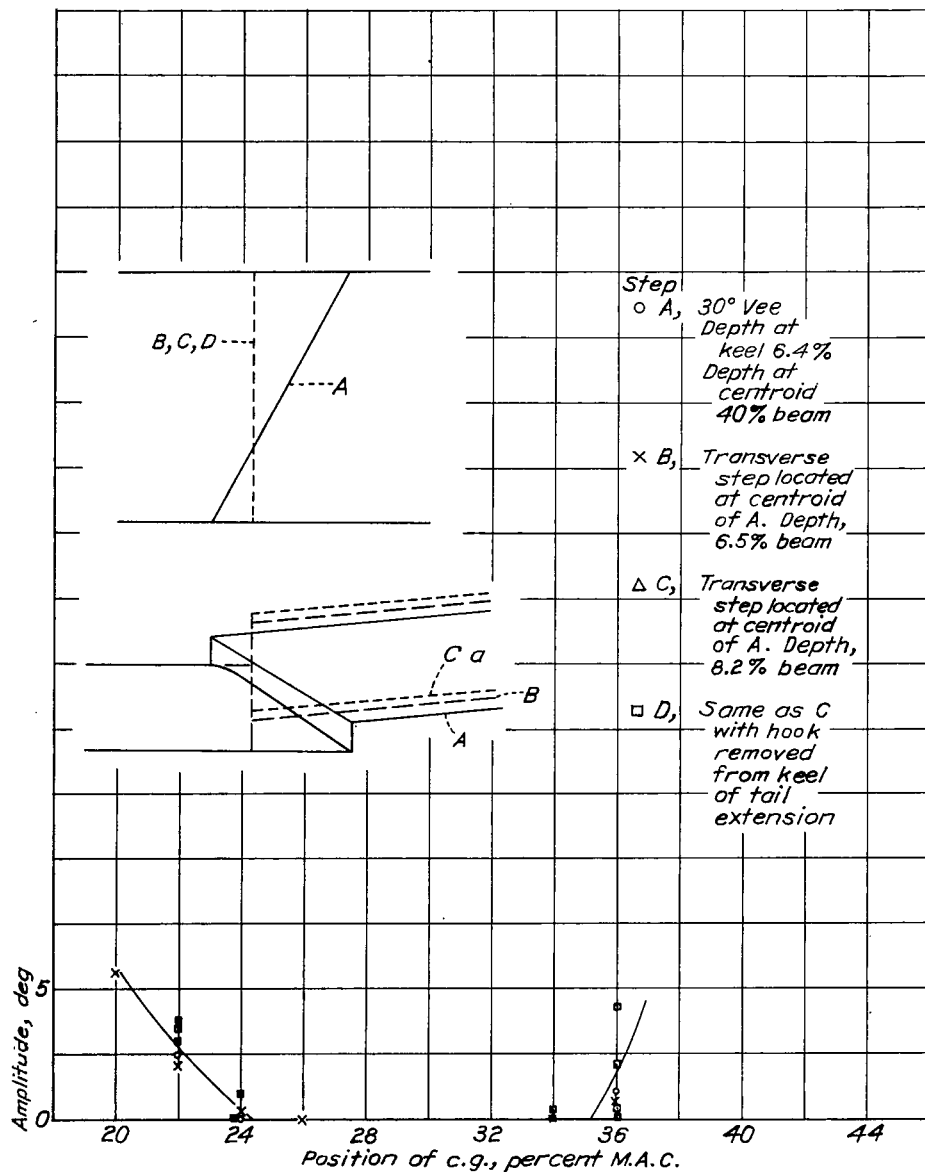

Figure 27.- Effect of plan form and depth of step on the maximum amplitude of porpoising. Model 16.

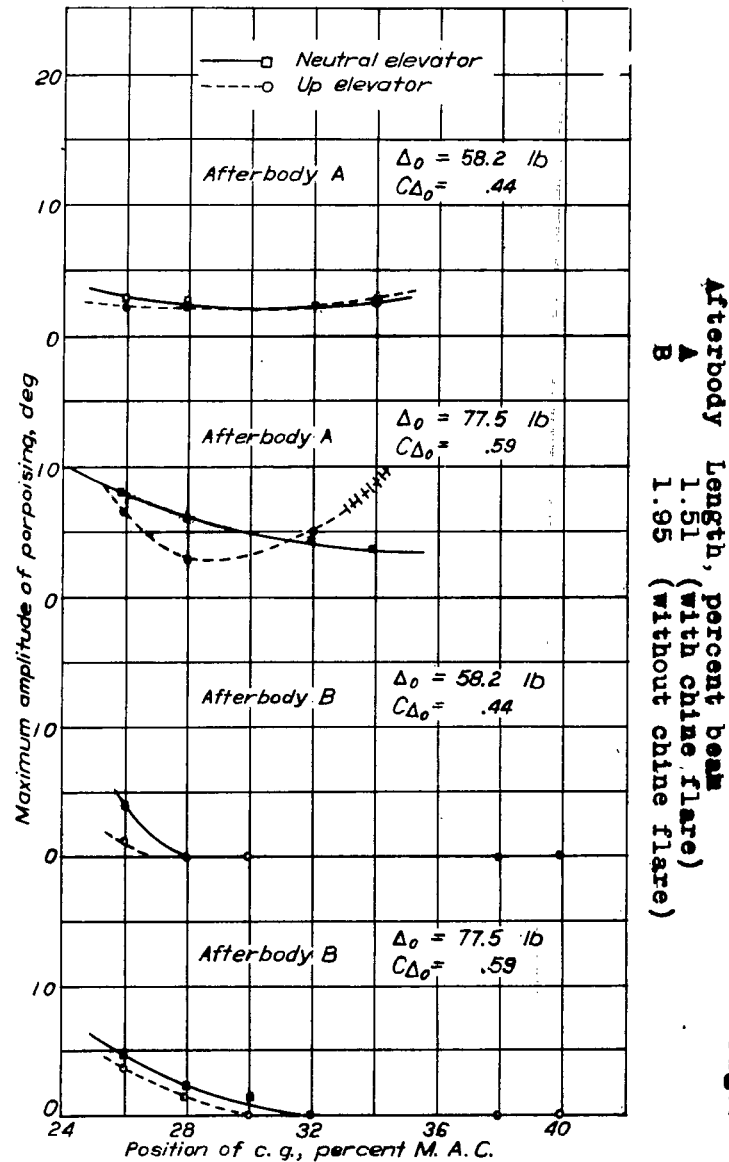

Figure 28.- Effect of length of afterbody on the maximum amplitude of porpoising. Model 17, 1/8 full-size.

LANGLEY RESEARCH CENTER



3 1176 01354 3245