

Record #
AAB3208

CONFIDENTIAL
CLASSIFICATION cancelled
12-4-53

Copy No. 16

RM No. L7F16

AERONAUTICS LIBRARY
California Institute of Technology



RESEARCH MEMORANDUM

LANGLEY FULL-SCALE-TUNNEL INVESTIGATION OF MAXIMUM LIFT
AND STABILITY CHARACTERISTICS OF AN AIRPLANE HAVING
APPROXIMATELY TRIANGULAR PLAN FORM (DM-1 GLIDER)

By

J. Calvin Lovell and Herbert A. Wilson, Jr.

Langley Memorial Aeronautical Laboratory
Langley Field, Va.

CLASSIFIED DOCUMENT

This document contains classified information affecting the National Defense of the United States within the meaning of the Espionage Act, USC 50:31 and 32. Its transmission or the revelation of its contents in any manner to an unauthorized person is prohibited by law. Information so classified may be imparted only to persons in the military and naval services of the United States, appropriate civilian officers and employees of the Federal Government who have a legitimate interest therein, and to United States citizens of known loyalty and discretion who of necessity must be informed thereof.

NATIONAL ADVISORY COMMITTEE
FOR AERONAUTICS

WASHINGTON
August 5, 1947

classified 12-4-53

1.2.2.2.1
1.7.7

CONFIDENTIAL

NATIONAL ADVISORY COMMITTEE FOR AERONAUTICS

RESEARCH MEMORANDUM

LANGLEY FULL-SCALE-TUNNEL INVESTIGATION OF MAXIMUM LIFT
AND STABILITY CHARACTERISTICS OF AN AIRPLANE HAVING
APPROXIMATELY TRIANGULAR PLAN FORM (DM-1 GLIDER)

By J. Calvin Lovell and Herbert A. Wilson, Jr.

SUMMARY

An investigation of the DM-1 glider, which had approximately triangular plan form, an aspect ratio of 1.8, and a 60° sweptback leading edge, has been conducted in the Langley full-scale tunnel. The investigation consisted of the determination of the separate effects of the following modifications made to the glider on its maximum lift and stability characteristics: (a) installation of sharp leading edges over the inboard semispan of the wing, (b) removal of the vertical fin, (c) sealing of the elevon control-balance slots, (d) installation of redesigned thin vertical surfaces, (e) installation of faired sharp leading edges, and (f) installation of canopy.

The maximum lift coefficient of the DM-1 glider was increased from 0.61 to 1.01 by the installation of semispan sharp leading edges, and from 1.01 to 1.24 by the removal of the vertical fin and sealing of the elevon control-balance slots. The highest maximum lift coefficient (1.32) was obtained when the faired sharp leading edges and the thin vertical surfaces were attached to the glider.

The original DM-1 glider was longitudinally stable. The semispan sharp leading edges shifted the neutral point forward approximately 3 percent of the root chord at moderate lift coefficients, and the glider configuration with these sharp leading edges attached was longitudinally unstable, for the assumed center-of-gravity location, at lift coefficients above 0.73. Sealing the elevon control-balance slots and installing the faired sharp leading edges, the thin vertical surfaces, and the canopy shifted the neutral point forward approximately 8 percent of the root chord.

The dihedral effect of the DM-1 glider with the vertical fin removed and elevon control-balance slots sealed was positive for lift coefficients up to 0.7. The semispan sharp leading edges extended the lift-coefficient range for positive dihedral effect up

to a lift coefficient of 1.0. The faired sharp leading edges, which increased the angle of sweepback 4.2° , reduced the highest lift coefficient for positive dihedral effect to 0.7.

The configurations of the DM-1 glider with no vertical fin had a small degree of directional stability at low lift coefficients and became directionally unstable at the higher lift coefficients. The thin vertical surfaces installed on the DM-1 wing having elevon control-balance slots sealed and semispan sharp leading edges attached contributed an increment of approximately -0.0024 to $C_{n\psi}$ thereby giving positive directional stability at all lift coefficients. The faired sharp leading edge and the P-80 canopy had destabilizing effects on $C_{n\psi}$.

The results indicate that airplanes having approximately triangular plan form with 60° sweepback and sharp leading edges can be designed to have acceptable stability characteristics in the subcritical speed range.

INTRODUCTION

Research directed toward the attainment of supersonic flight has led to interest in the characteristics of wings of high sweep and of low aspect ratio. Since there are only limited full-scale data on such wings, an investigation of the German DM-1 glider has been conducted in the Langley full-scale tunnel. The DM-1 glider, which was designed for the investigation of the low-speed characteristics of an airplane configuration believed suitable for supersonic flight, has approximately triangular plan form, airfoil sections similar to the NACA 0015-64, an aspect ratio of 1.8, and a 60° sweptback leading edge.

Preliminary tests of the DM-1 glider in the Langley full-scale tunnel disclosed that the maximum lift coefficient was considerably lower than had been indicated by low-scale tests of similar configurations. In an effort to increase the maximum lift coefficient, the effects of sharp leading edges, redesigned vertical surfaces, and other modifications to the DM-1 glider were investigated. In addition to the maximum-lift tests, an investigation was made of the stability and control characteristics of those glider configurations believed most suitable.

The results of the major part of the maximum-lift investigation have been presented in reference 1. The present paper gives the results of the stability and control investigation and also includes a brief summary of the maximum-lift results.

SYMBOLS

The data are referred to the stability axes, which are defined in figure 1. The moments are given about center-of-gravity locations assumed to be at 50 percent of the root chord. (See figs. 2(a) and 2(c).) The wing area of the original DM-1 glider (215 sq ft) was used in computing the coefficients of glider configurations 1 to 6. The wing area of glider configurations 7 and 8 (232 sq ft) was used as a basis for the coefficients of these configurations.

C_L	lift coefficient (L/qS)
$C_{L_{max}}$	maximum lift coefficient
C_X	longitudinal-force coefficient (X/qS)
C_Y	lateral-force coefficient (Y/qS)
C_l	rolling-moment coefficient (L'/qSb)
C_m	pitching-moment coefficient (M/qSc')
C_n	yawing-moment coefficient (N/qSb)
C_{h_e}	elevator hinge-moment coefficient $\left(\frac{H_e}{qb_e c_e^2}\right)$
L	lift
X	longitudinal force
Y	lateral force
L'	rolling moment about X-axis
M	pitching moment about Y-axis
N	yawing moment about Z-axis
H_e	elevator hinge moment
q	dynamic pressure $\left(\frac{1}{2}\rho V^2\right)$

ρ	mass density of air
V	free-stream velocity
R	Reynolds number
S	wing area
c_1	root chord of glider configuration 1
c'	mean geometric chord of wing (S/b)
b	span of wing
b_e	elevator span, feet
\bar{c}_e	elevator root-mean-square chord behind hinge line, feet
$C_{l\psi}$	rate of change of rolling-moment coefficient with angle of yaw, per degree
$C_{n\psi}$	rate of change of yawing-moment coefficient with angle of yaw, per degree
$C_{Y\psi}$	rate of change of lateral-force coefficient with angle of yaw
α	angle of attack (measured in plane of symmetry), degrees
ψ	angle of yaw (positive when right wing is back), degrees
$\left(\frac{dC_m}{d\delta_e}\right)_{\delta_e=0}$	rate of change of pitching-moment coefficient with elevator deflection measured at $\delta_e = 0^\circ$
δ_e	angle of elevator deflection (positive down), degrees
δ_f	angle of flap deflection (positive down), degrees

TEST AIRPLANE AND MODIFICATIONS

The DM-1 glider was designed in Germany for the investigation of the low-speed characteristics of an airplane configuration believed suitable for supersonic flight.

The DM-1 glider has an approximately triangular plan form, airfoil sections similar to the NACA 0015-64, an aspect ratio of 1.8, and a 60° sweptback leading edge. It was constructed almost entirely of wood, the skin was $\frac{1}{16}$ -inch three-ply birch plywood, and the spars and ribs were of conventional box-beam construction. The principal dimensions of the glider are given in figure 2 and table I. General views of the glider mounted in the Langley full-scale tunnel for tests are given in figure 3. The glider as received was equipped with a rudder for directional control, elevons for lateral and longitudinal control, and longitudinal trim flaps. The balance on the control surfaces was of the elliptical overhang type. The balance gap was relatively large, however, and the shape of the wing just ahead of the balance gap was elliptical. (See fig. 2(b).)

Following the basic tests of the original DM-1 configuration, numerous modifications were made to the glider in an effort to improve its aerodynamic characteristics. These glider modifications, which are referred to throughout the present report by configuration numbers, are sketched in figure 4 and are outlined as follows:

- Configuration 1: Original DM-1 glider. (See figs. 2(a) and 3(a).)
- Configuration 2: DM-1 glider with semispan sharp leading edges attached. (See fig. 2(b).)
- Configuration 3: DM-1 glider with vertical fin removed.
- Configuration 4: DM-1 glider with vertical fin removed and elevon control-balance slots sealed.
- Configuration 5: DM-1 glider with vertical fin removed, elevon control-balance slots sealed, and semispan sharp leading edges installed.
- Configuration 6: Same as configuration 5 with the redesigned thin vertical surfaces shown in figure 2(c) installed. These vertical surfaces were, for simplicity of construction and installation, made with rectangular sections three-quarters of an inch thick.
- Configuration 7: Same as configuration 6 with the faired sharp leading edges shown in figure 2(c) replacing the semispan sharp leading edges.
- Configuration 8: Same as configuration 7 with the P-80 canopy added. (See figs. 2(c) and 3(b).)

METHODS AND TESTS

The tunnel airspeed for the tests was limited to approximately 45 miles per hour because the structure inside the glider, which was available for connection with the model supporting struts, was exceedingly fragile. The tests of glider configurations 1 to 5 were conducted at this airspeed, which corresponds to a Reynolds number of 4.6×10^6 based on the mean geometric chord of glider configuration 1 (10.97 ft). Buffeting of configurations 6, 7, and 8 necessitated a reduction in tunnel airspeed for tests of these configurations to 36 miles per hour.

In order to determine the separate effects of the component parts and modifications of the DM-1 glider on its aerodynamic characteristics at zero yaw, the forces and moments on each glider configuration were measured throughout the angle-of-attack range with all control surfaces locked at 0° deflection. Tests were conducted for configurations 1, 2, and 8 in order to determine the effect of the semispan sharp leading edges and of the modifications of configuration 8 on the elevator effectiveness and on the longitudinal stability characteristics of the glider. The elevator hinge moments and the effectiveness of the trim flaps of glider configuration 2 were also determined. The lateral stability characteristics of glider configurations 3 to 8 with control surfaces neutral were investigated by determining the aerodynamic characteristics of each configuration at angles of yaw of approximately 0° , $\pm 3^\circ$, $\pm 5^\circ$, -10° , -15° , and -20° .

RESULTS AND DISCUSSION

The results of the DM-1 investigation are summarized in figures 4 to 10, and the basic data from which the summary figures were prepared are presented in figures 11 to 21. An index to these figures is given in table II. All the test results have been corrected for the effect of the jet boundaries on the drag coefficient and the angle of attack. No correction has been applied to the data, however, for the effect of the jet boundaries on the rolling-moment coefficient or for the tare of the model supporting struts, which were found to be of negligible magnitude.

Maximum Lift

The summary results of the maximum-lift investigation of the eight DM-1 glider configurations are given in figure 4. The maximum lift coefficient of the original DM-1 glider (configuration 1) was increased from 0.61 to 1.01 by the installation of the semispan sharp leading edges shown in figure 2(b). These sharp leading edges induce a vortex-type flow over the upper surface of the wing which delays the stall to much higher angles of attack. (See reference 1.) The maximum lift coefficient of the glider was also increased from 0.61 to 0.93 by the removal of the vertical fin. The maximum lift coefficient of the glider with vertical fin removed (configuration 3) was increased from 0.93 to 1.08 by the sealing of elevon control-balance slots, and from 1.08 to 1.24 by the installation of the semispan sharp leading edges. The addition of the redesigned vertical surfaces to glider configuration 5 increased the maximum lift coefficient from 1.24 to 1.29. The highest maximum lift coefficient measured (1.32) was obtained for glider configuration 7, which had the faired sharp leading edges and the redesigned vertical surfaces installed. The addition of the P-80 canopy to glider configuration 7 decreased the maximum lift coefficient to 1.27. The aerodynamic characteristics of each of these eight DM-1 glider configurations, throughout the angle-of-attack range, are shown in figure 11.

The effect of yaw on the lift characteristics of glider configurations 3 to 8 are also shown in figure 11. The lift characteristics of glider configuration 3 were not affected in any systematic manner by angles of yaw up to -9.9° . The lift coefficient at any angle of attack was, however, decreased somewhat by yaw angles of -14.9° and -19.9° . As the maximum lift coefficient of the glider was increased by the modifications of glider configurations 4 to 8, the lift coefficient became increasingly dependent on yaw angle. The lift coefficients at an angle of attack of 38° and zero yaw for glider configurations 4, 5, 6, 7, and 8 were decreased by increments (ΔC_L) of 0.12, 0.13, 0.26, 0.37, and 0.39, respectively, by -9.9° of yaw.

The effect of tunnel velocity on the lift coefficient of glider configuration 2 is shown in figure 12. These data were obtained at tunnel velocities of 29 to 52 miles per hour, which correspond to Reynolds numbers of 3.0×10^6 to 5.3×10^6 , respectively. The maximum lift coefficients measured at these Reynolds numbers indicate that the reduction in tunnel velocity from 45 to 36 miles per hour, which was necessary for the tests of glider configurations 6, 7, and 8, had no appreciable effect on $C_{L_{max}}$.

Longitudinal Stability and Control

Longitudinal stability and control, stick fixed.- The stick-fixed static longitudinal stability and control characteristics of glider configurations 1, 2, and 8 for the center-of-gravity locations assumed are indicated by the curves of figure 5. These results, which give the elevator deflection for trim at various lift coefficients, were obtained from the curves of figures 13 and 14. The rate of change of elevator deflection with lift coefficient for configuration 1 (original DM-1 glider) indicates stable elevator-control movement throughout the lift-coefficient range investigated. Glider configuration 2, which had the semispan sharp leading edge attached, is statically stable up to a lift coefficient of 0.73, above which the elevator deflection for trim is in the unstable direction. Glider configuration 8 was statically stable for lift coefficients up to 0.87, above which elevator-effectiveness data were not available. The variation of C_m with C_L for configuration 8 with controls neutral, however, indicates that this configuration has static longitudinal stability for lift coefficients up to 1.25.

The static longitudinal stability characteristics of configurations 1, 2, and 8 for any center-of-gravity location can be determined from the curves of figure 6, which show the center-of-gravity locations at which the longitudinal stability is neutral when the glider is trimmed. The location of the neutral point of configuration 1 moves rearward from $0.520c_1$ at $C_L = 0.1$ to $0.546c_1$ at $C_L = 0.46$. The vortex-type flow induced by the semispan sharp leading edges of glider configuration 2 shifts the center of pressure of the wing forward, decreasing the static margin, so that less elevator deflection is required to trim configuration 2, as was previously indicated by the curves of figure 5. The neutral point of configuration 2 is at $0.514c_1$ at lift coefficients up to 0.5, and above this lift coefficient the neutral-point location moves forward with increasing lift coefficient. At lift coefficients above 0.73, the neutral point is located forward of the center of gravity, making the glider unstable. The modifications of glider configuration 8, which add 16.9 square feet of area at the leading edge of the wing, move the neutral point forward to approximately $0.475c_1$. This point, however, corresponds to 0.530 of the root chord of configuration 8, so the configuration is longitudinally stable, for the center-of-gravity location assumed (0.50 of root chord).

It is of interest to compare the neutral-point locations of the DM-1 glider with the theoretical neutral-point location for a wing of similar plan form. Falkner has made calculations (reference 2) which show that the neutral point of a delta wing (equilateral triangle with apex forward) is located at 58 percent of its root chord, which point corresponds to 50.6 percent of the root chord of the DM-1. This result is in good agreement with the neutral-point locations of DM-1 glider configurations 1 and 2, which have plan forms approximating an equilateral triangle.

Elevator effectiveness.- The results of the elevator-effectiveness tests of glider configurations 1, 2, and 8 are given in figure 7, which

shows the variation of $\left(\frac{dC_m}{d\delta_e}\right)_{\delta_e=0}$ with angle of attack. The elevator

effectiveness $-\left(\frac{dC_m}{d\delta_e}\right)_{\delta_e=0}$ of configuration 1 reaches its maximum

value of 0.0050 at an angle of attack of 10° and then decreases with

increasing angle of attack to 0.0037 at 17° . The value of $-\left(\frac{dC_m}{d\delta_e}\right)_{\delta_e=0}$

for configuration 2 is 0.0045 at an angle of attack of 10° , and

decreases to 0.0034 at $\alpha = 28^\circ$. This decrease in $-\left(\frac{dC_m}{d\delta_e}\right)_{\delta_e=0}$ with

angle of attack is less rapid for configuration 2 because the semi-span sharp leading edges maintain orderly flow over the elevon surfaces at higher angles of attack. The effectiveness of the elevators of

configuration 8 remains substantially constant at $-\left(\frac{dC_m}{d\delta_e}\right)_{\delta_e=0} = 0.0042$

throughout the angle-of-attack range investigated.

Trim-flap effectiveness.- The effect of trim-flap deflection on the aerodynamic characteristics of glider configuration 2 is shown in figure 15. The rate of change of pitching-moment coefficient with trim-flap deflection is approximately constant throughout the flap-deflection range ($\pm 11^\circ$) and increases slightly with lift coefficient. At a trim lift coefficient of 0.86, 5° of trim-flap deflection and 2° of elevator deflection give corresponding increments of pitching-moment coefficient. The trim flap alone, however, is not sufficiently powerful to trim the glider, for the center-of-gravity location assumed, at any lift coefficient.

Lateral Stability and Control

The separate effects of the modifications made to the DM-1 glider on $C_{l\psi}$, $C_{n\psi}$, and $C_{y\psi}$ are shown in figures 8, 9, and 10. These values of $C_{l\psi}$, $C_{n\psi}$, and $C_{y\psi}$ were obtained from the variation of C_L , C_n , and C_y with ψ , at small angles of yaw ($\psi = \pm 5^\circ$), which is shown in figures 16 to 21.

Dihedral effect.- The value of $C_{l\psi}$ for glider configuration 3, (original glider with vertical fin removed) increases from 0 at zero lift to 0.0019 at C_L of 0.5; and as C_L increases above 0.5, $C_{l\psi}$ decreases, reaching 0 at C_L of 0.68 and -0.002 at C_L of 0.9. Sealing the elevon control-balance slots (configuration 4) did not change the dihedral effect of the wing. The semispan sharp leading edges of configuration 5 increased the dihedral effect of the glider. The maximum value of $C_{l\psi}$ for this configuration was 0.0024 (which value in terms of a conventional unswept wing of aspect ratio 6 corresponds to 12° effective dihedral), and the dihedral effect was positive for lift coefficients up to 1.0. This increase in dihedral effect is probably due to the vortex action induced by the semispan sharp leading edges, which delay the stall of the leading wing tip. The addition of the redesigned vertical fin to glider configuration 5 had no appreciable effect on $C_{l\psi}$. The effective dihedral of glider configuration 6 was considerably reduced by the replacement of the semispan sharp leading edges by the faired sharp leading edges of configuration 7, probably because of the increased angle of sweepback. The maximum value of $C_{l\psi}$ for configuration 7 was 0.0014, which decreased to 0 at a lift coefficient of 0.7, and to -0.0030 at a lift coefficient of 1.15. The P-80 canopy of configuration 8 did not affect $C_{l\psi}$ appreciably at lift coefficients below 0.9. At lift coefficients above 0.9, however, the canopy contributed a destabilizing increment to $C_{l\psi}$, which decreased the minimum value of $C_{l\psi}$ to -0.005 at a lift coefficient of 1.15.

Directional stability.- The original DM-1 glider wing (configuration 3) had a small degree of directional stability at lift coefficients between 0.3 and 0.7. The minimum value of $C_{n\psi}$ for configuration 3 was -0.0007 at C_L of 0.55, and at lift coefficients

above this value $C_{n\psi}$ increased with lift coefficient to unstable values at lift coefficients above 0.7. The sealing of the elevon control-balance slots had no effect on the minimum value of $C_{n\psi}$, but the lift coefficient at which the directional stability of configuration 4 became neutral was increased to 0.81. The semispan sharp leading edges of configuration 5 also extended the lift-coefficient range over which the directional stability was positive ($C_{n\psi} = 0$ at $C_L = 1.05$), although the minimum value of $C_{n\psi}$ remained at -0.0007.

The directional stability provided by the redesigned thin vertical surfaces is shown by the comparison of $C_{n\psi}$ for glider configurations 5 and 6 in figure 9. The vertical surfaces of configuration 6 contributed a stable increment of approximately -0.0024 to $C_{n\psi}$ throughout the lift-coefficient range investigated.

$C_{n\psi}$ for configuration 6 was -0.0024 at C_L of 0.3, -0.0034 at C_L of 0.8, and -0.0012 at C_L of 1.1. These values of $C_{n\psi}$ are believed to be adequate for satisfactory flying qualities.

The directional stability of glider configuration 6 was reduced at lift coefficients above 0.7 by the faired sharp leading edges of configuration 7. The value of $C_{n\psi}$ for configuration 7 was -0.0002 at C_L of 1.1, and 0 at C_L of 1.2. The P-80 canopy of configuration 8 had a destabilizing effect on $C_{n\psi}$ which increased with C_L , reducing the directional stability to neutral at C_L of 1.0.

Lateral-force effect.- Glider configurations 3 and 4 had zero lateral-force effect at lift coefficients up to 0.5, above which $C_{Y\psi}$ increased almost linearly with C_L to 0.008 at C_L of 0.85. The lateral-force effect of configuration 5 increased from 0 at lift coefficients below 0.8 to 0.005 at C_L of 1.1. The lateral-force characteristics of the three glider configurations which had the redesigned thin vertical surfaces attached (configurations 6, 7, and 8) had the same lateral-force characteristics. The values of $C_{Y\psi}$ for these configurations were approximately 0.007 at a lift coefficient of 0.3 and increased slightly with lift coefficient to approximately 0.008 at a lift coefficient of 1.1.

SUMMARY OF RESULTS

The results of tests of eight configurations of the DM-1 glider in the Langley full-scale tunnel are summarized as follows:

1. The maximum lift coefficient of the DM-1 glider was increased from 0.61 to 1.01 by the installation of semispan sharp leading edges. Removing the vertical fin from the glider and sealing the elevon control-balance slots increased the maximum lift coefficient to 1.24. The highest maximum lift coefficient (1.32) was obtained when faired sharp leading edges and thin vertical surfaces were installed on the glider.

2. The maximum lift coefficient of the original DM-1 glider with vertical fin removed was not critically dependent on yaw angle. As the maximum lift coefficient was increased, however, by sealing of the elevon control-balance slots and by installation of sharp leading edges, systematic decreases in the maximum lift coefficient resulted from yaw.

3. The original DM-1 glider was longitudinally stable for the assumed center-of-gravity position. The semispan sharp leading edges shifted the neutral point forward approximately 3 percent of the root chord at moderate lift coefficients, and the glider configuration with these sharp leading edges attached was longitudinally unstable, for the assumed center-of-gravity location, at lift coefficients above 0.73. Sealing the elevon control-balance slots and installing faired sharp leading edges, thin vertical surfaces, and the canopy shifted the neutral point forward approximately 8 percent of the root chord in the lift-coefficient range investigated.

4. The dihedral effect of the original DM-1 glider with vertical fin removed was positive at lift coefficients up to 0.7. The semispan sharp leading edges extended the lift-coefficient range for positive dihedral effect up to a lift coefficient of 1.0. The faired sharp leading edges decreased the highest lift coefficient for positive dihedral effect to 0.7. The redesigned vertical surfaces did not change the dihedral effect of the glider.

5. The configurations of the DM-1 glider with no vertical fin had a small degree of directional stability at low lift coefficients and became directionally unstable at the higher lift coefficients. The redesigned thin vertical surfaces installed on the DM-1 wing having elevon control-balance slots sealed and semispan

sharp leading edges attached contributed an increment of approximately -0.0024 to $C_{n\psi}$, thereby giving the glider configuration directional stability at all lift coefficients. The faired sharp leading edges and the P-80 canopy had destabilizing effects on $C_{n\psi}$.

6. These results indicate that airplanes having approximately triangular plan form with 60° sweepback and sharp leading edges can be designed to have acceptable stability characteristics in the subcritical speed range.

Langley Memorial Aeronautical Laboratory
National Advisory Committee for Aeronautics
Langley Field, Va.

REFERENCES

1. Wilson, Herbert A., Jr., and Lovell, J. Calvin: Full-Scale Investigation of the Maximum Lift and Flow Characteristics of an Airplane Having Approximately Triangular Plan Form. NACA RM No. L6K20, 1946.
2. Falkner, V. M.: Calculations of the Aerodynamic Loading of a Delta Wing. 9830, S. & C. 2038, Perf. 202, British A.R.C., July 29, 1946.

TABLE I

DIMENSIONS OF DM-1 GLIDER

Original Glider

Wing:

Span, ft	19.6
Area, sq ft	215.0
Aspect ratio	1.8
Airfoil section	Approximately NACA 0015-64
Thickness, percent chord	15
Point of greatest thickness, percent chord	40
Root chord, ft	20.75
Mean geometric chord, ft	10.97
Twist, deg	0
Dihedral, deg	0
Sweepback (L.E.), deg	60
Sweepforward (T.E.), deg	15
Vertical location of center of gravity, percent root chord from chord line	0
Horizontal location of center of gravity, percent root chord	50

Horizontal control surfaces:

Total elevon area, sq ft	23.3
Elevon chord, ft	1.95
Elevon hinge location, percent chord	27
Elevator-angle range, deg	28 to -24
Aileron-angle range, deg	21 to -21
Total trim-flap area, sq ft	6.97
Trim-flap chord, ft	1.38

Vertical tail:

Height, ft	8.58
Area (to chord line of wing), sq ft	89.6
Aspect ratio	0.82
Airfoil section	Approximately NACA 0015-64
Thickness, percent chord	17.5
Point of greatest thickness, percent chord	40
Root chord, ft	19.7
Angle of sweepback (L.E.), deg	65
Angle of sweepforward (T.E.), deg	0
Rudder area, sq ft	8.01
Rudder chord, ft	1.32
Hinge location, percent chord	27
Rudder-angle range, deg	±23

TABLE I - Concluded

DIMENSIONS OF DM-1 GLIDER - Concluded

Modifications

Semispan sharp leading edges:

Length, ft	10.83
Width, in.	3
Thickness, in.	0.06
Area, sq ft	5.42

Vertical fin:

Height, ft	6.85
Area (to chord line), sq ft	33.3
Aspect ratio	1.41
Thickness, in.	0.75
Root chord, ft	9.79
Angle of sweepback (L.E.), deg	35
Angle of sweepforward (T.E.), deg	0

Ventral fin:

Height, ft	1.56
Area (to wing profile), sq ft	6.22
Thickness, in.	0.75

Faired sharp leading edge:

Length, ft	16.3
Total projected area, sq ft	16.9

NATIONAL ADVISORY
COMMITTEE FOR AERONAUTICS

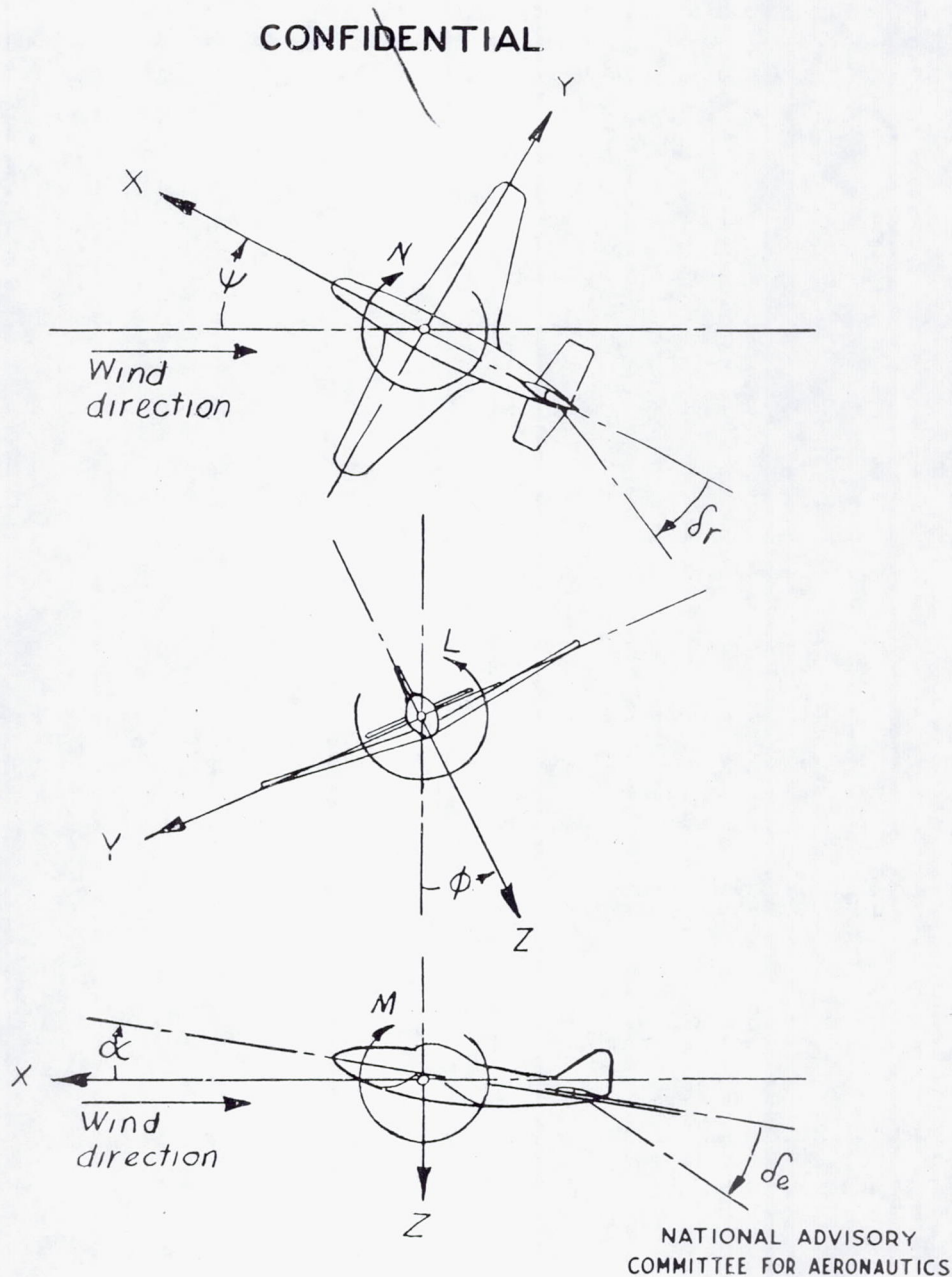
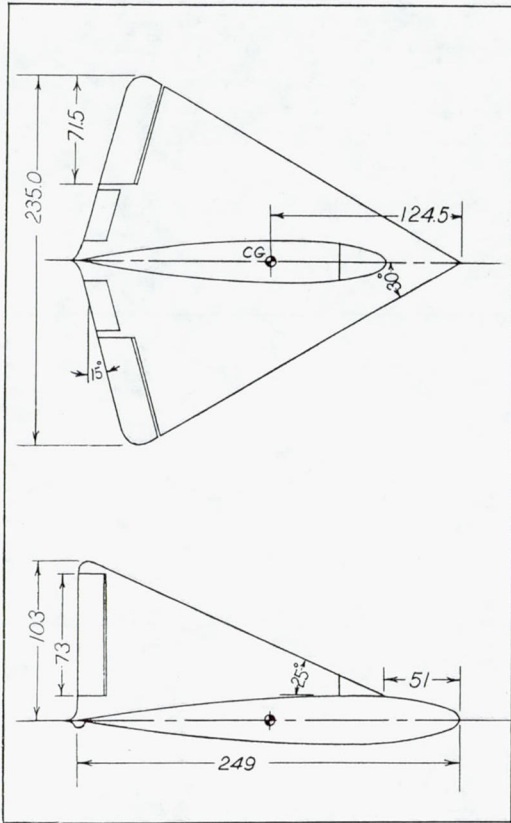
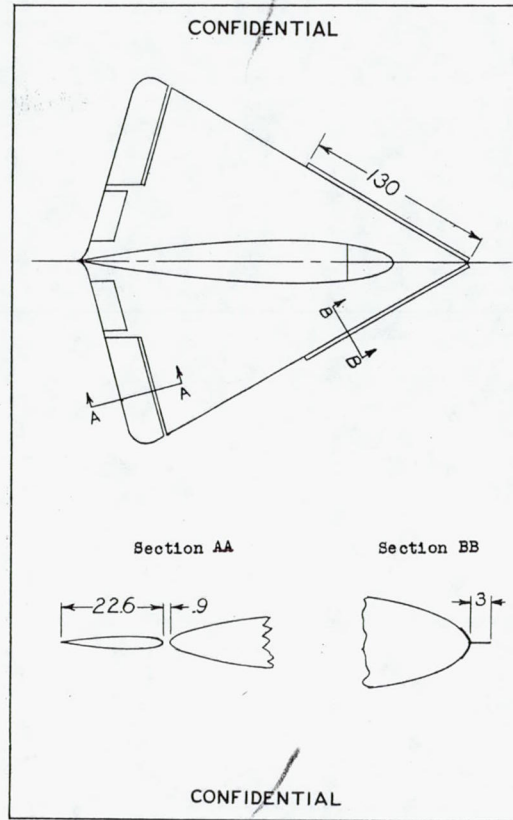

Figure 1.-The stability system of axes. Arrows indicate positive directions of moments, forces, and control-surface deflections. This system of axes is defined as an orthogonal system having their origin at the center of gravity and in which the Z-axis is in the plane of symmetry and perpendicular to the relative wind, the X-axis is in the plane of symmetry and perpendicular to the Z-axis, and the Y-axis is perpendicular to the plane of symmetry.



(a) Principal dimensions of glider configuration 1 (original DM-1 glider).



(b) Dimensions of the semispan sharp leading edges and of the elevon control-balance slots.

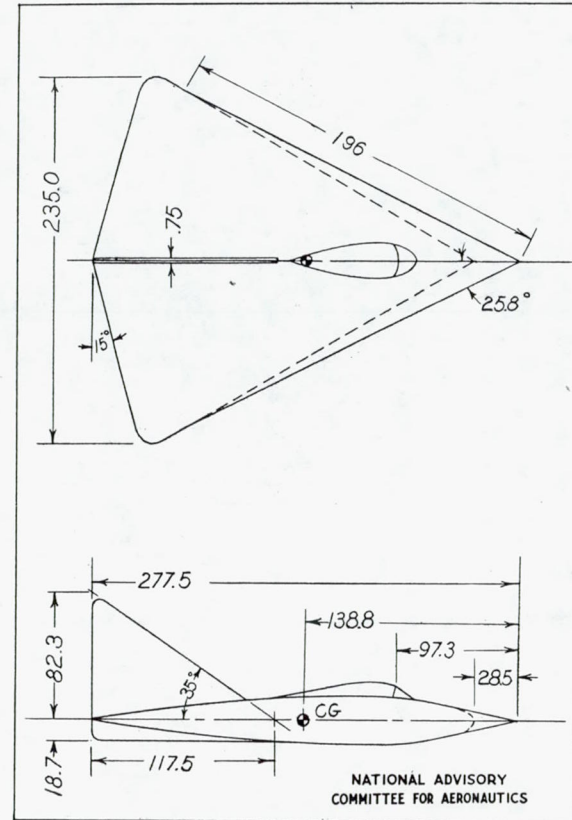

(c) Principal dimensions of glider configuration 8.

Figure 2 .- Dimensions of the DM-1 glider. (All dimensions in inches.)

~~CONFIDENTIAL~~

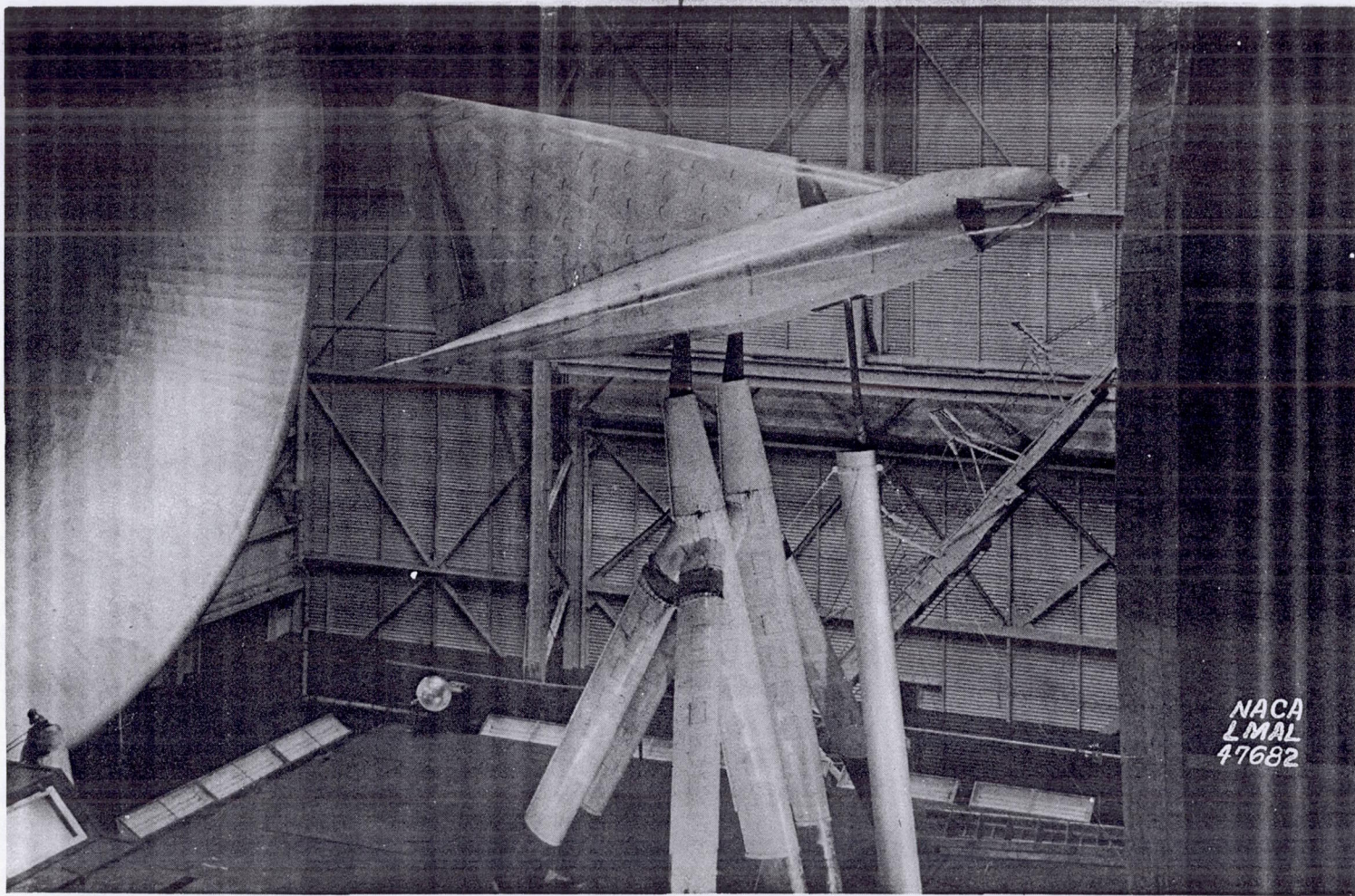

NACA RM No. L7F16

(a) Glider configuration 1, three-quarter side view.

Figure 3.- DM-1 glider mounted for tests in Langley full-scale tunnel.

~~CONFIDENTIAL~~

Fig. 3a

~~CONFIDENTIAL~~

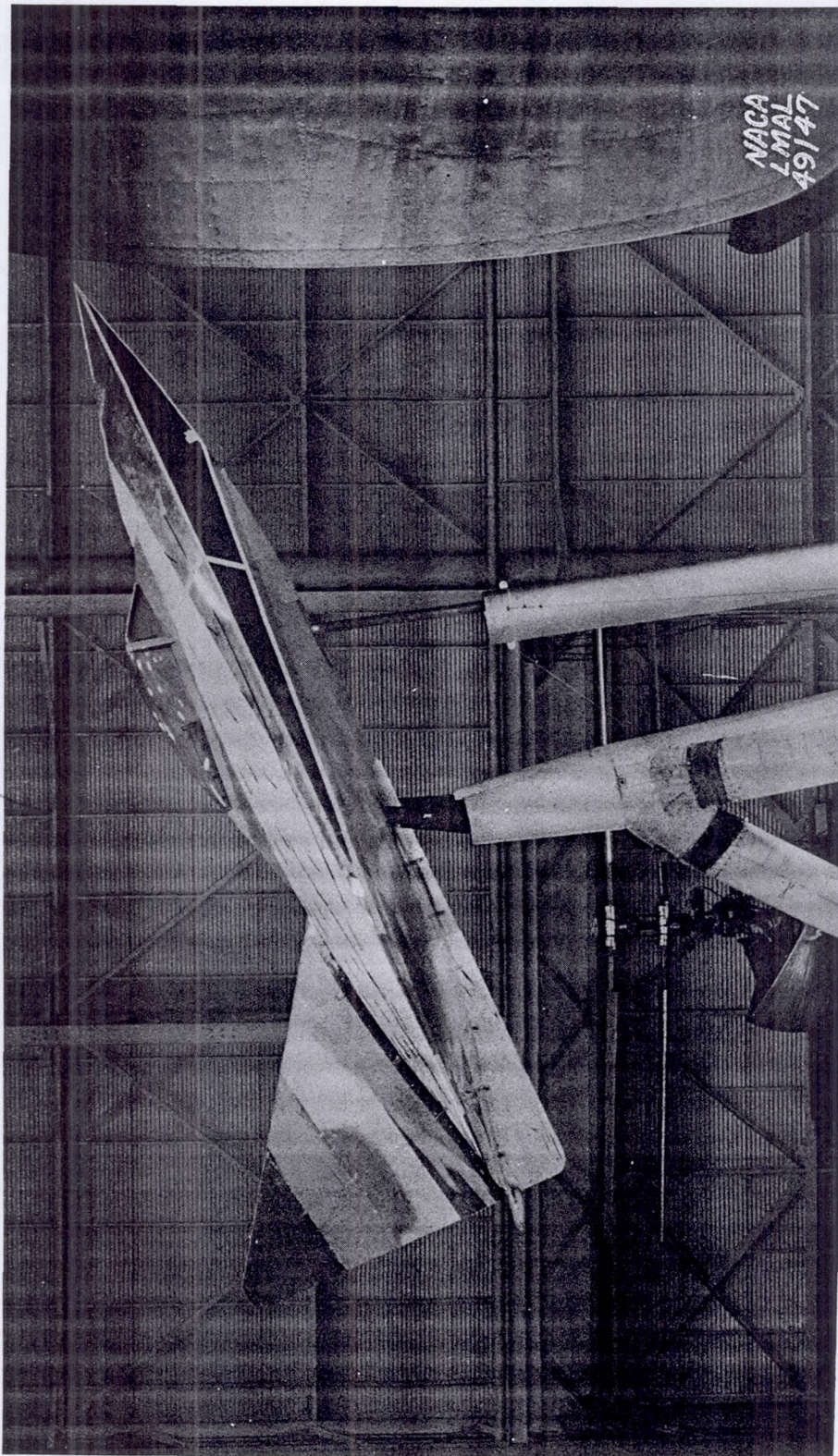

(b) Glider configuration 8, side view.

Figure 3.- Concluded.

~~CONFIDENTIAL~~

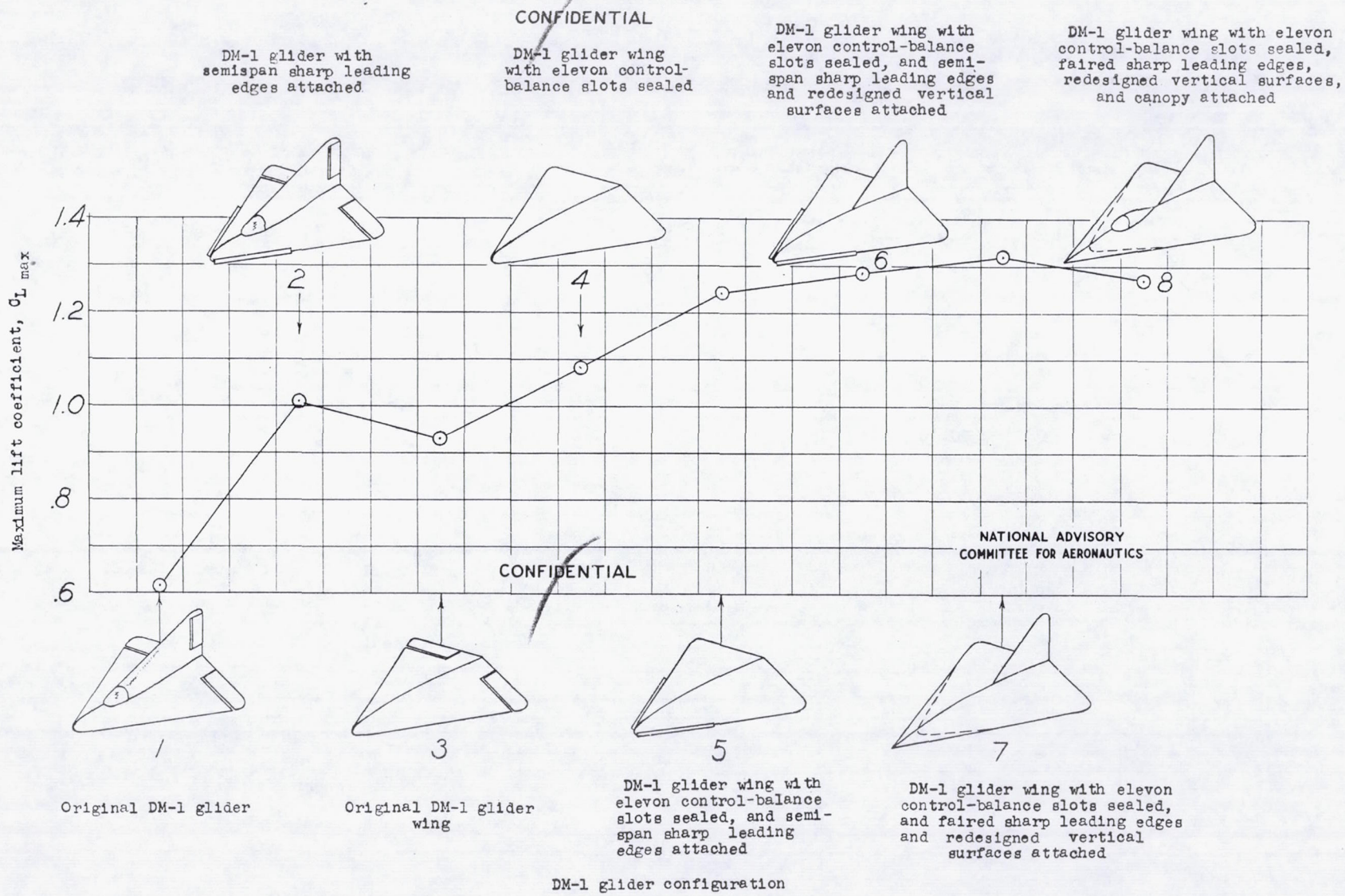
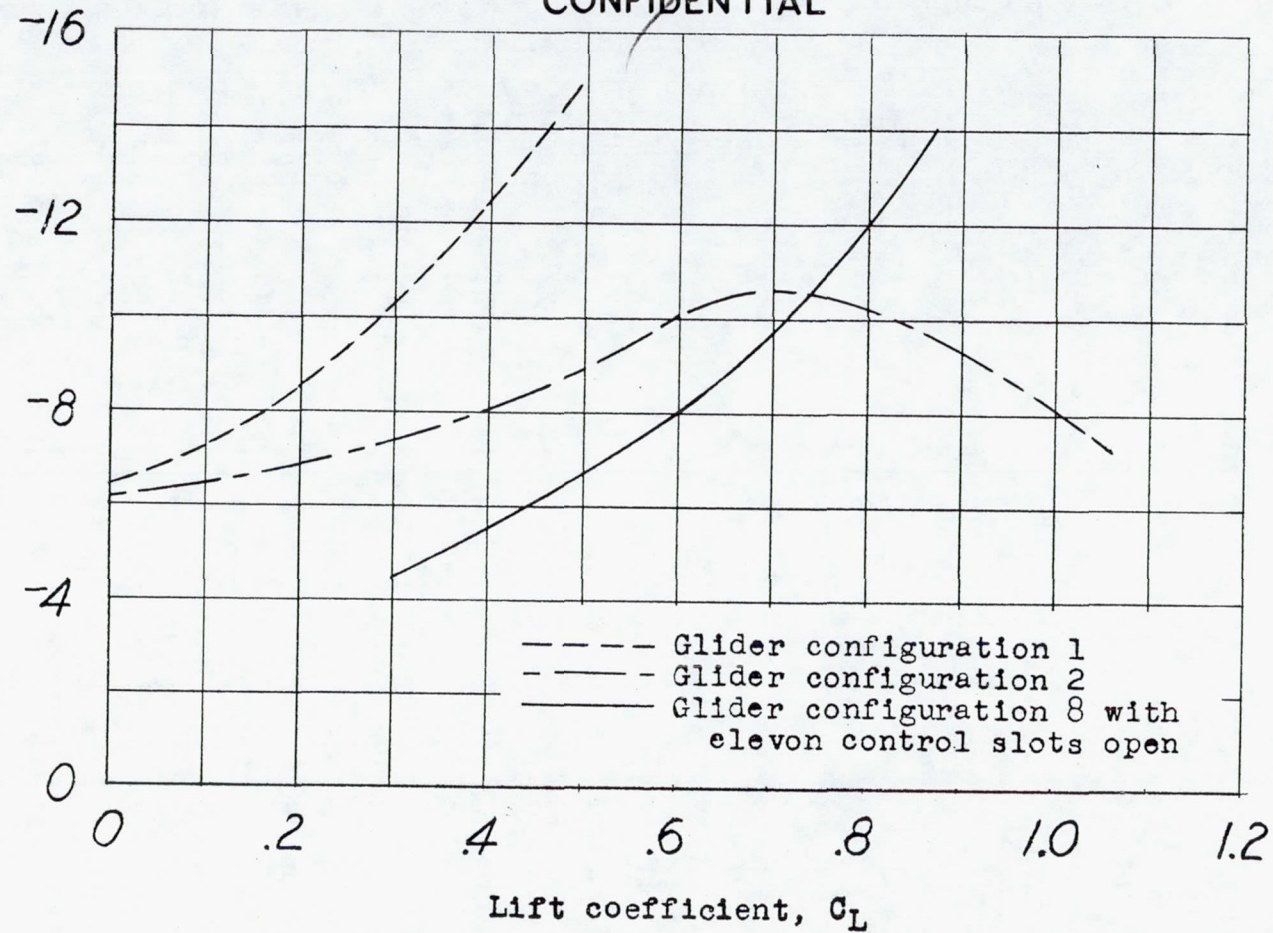

Figure 4.- Summary of the effects of the modifications made to the DM-1 glider on the maximum lift coefficient.

Elevator deflection for trim, δ_e , degrees



~~CONFIDENTIAL~~

NATIONAL ADVISORY
COMMITTEE FOR AERONAUTICS

Figure 5.- Variation of elevator deflection for trim ($C_m = 0$) with lift coefficient for DM-1 glider configurations 1, 2, and 8.

Neutral-point location, percent original root chord

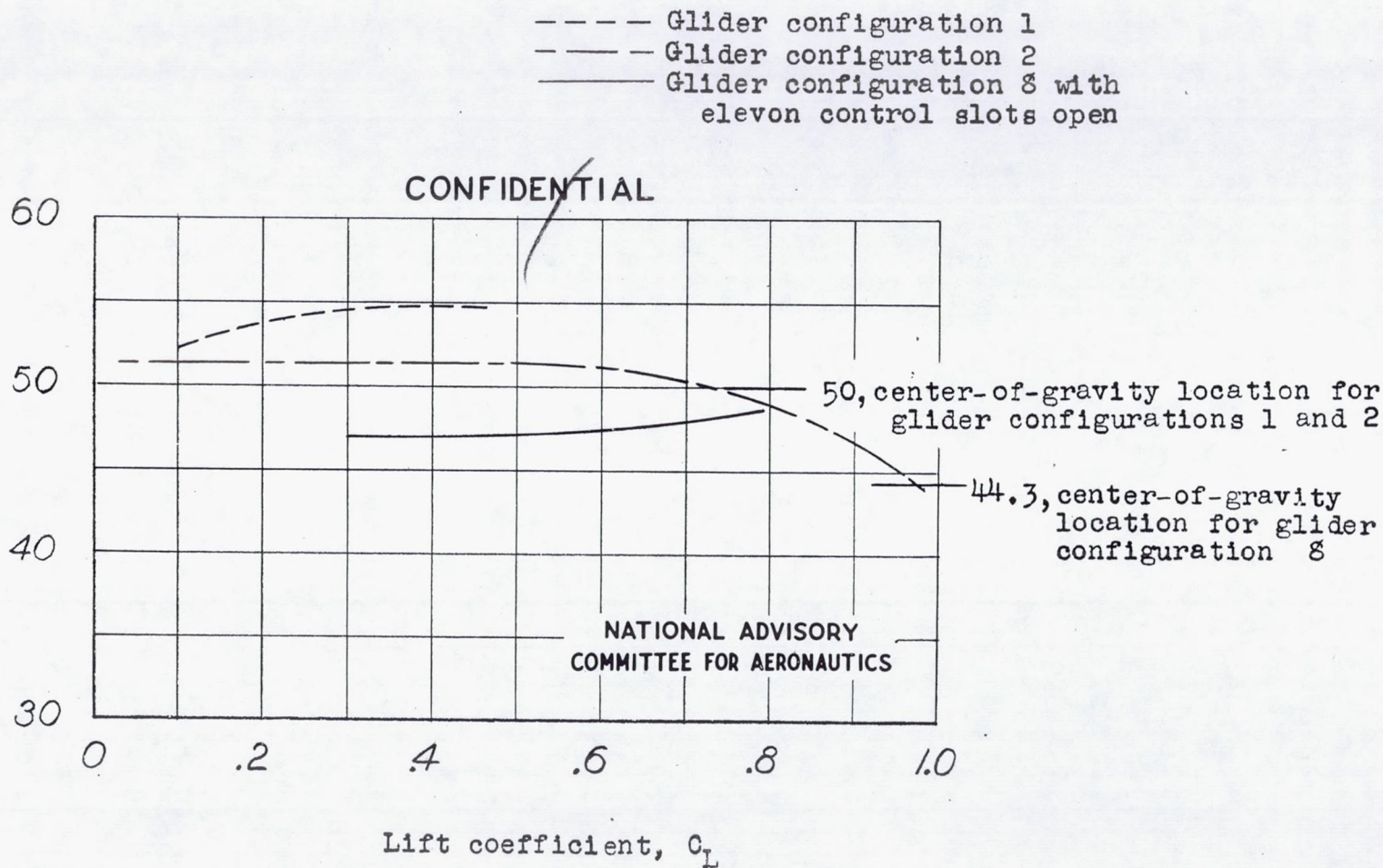

CONFIDENTIAL

Figure 6 .- Variation of neutral-point location with lift coefficient for DM-1 glider configurations 1, 2, and 8.

Rate of change of pitching-moment coefficient with
 elevator deflection, $\left(\frac{d C_m}{d \delta_e}\right)_{\delta_e=0}$

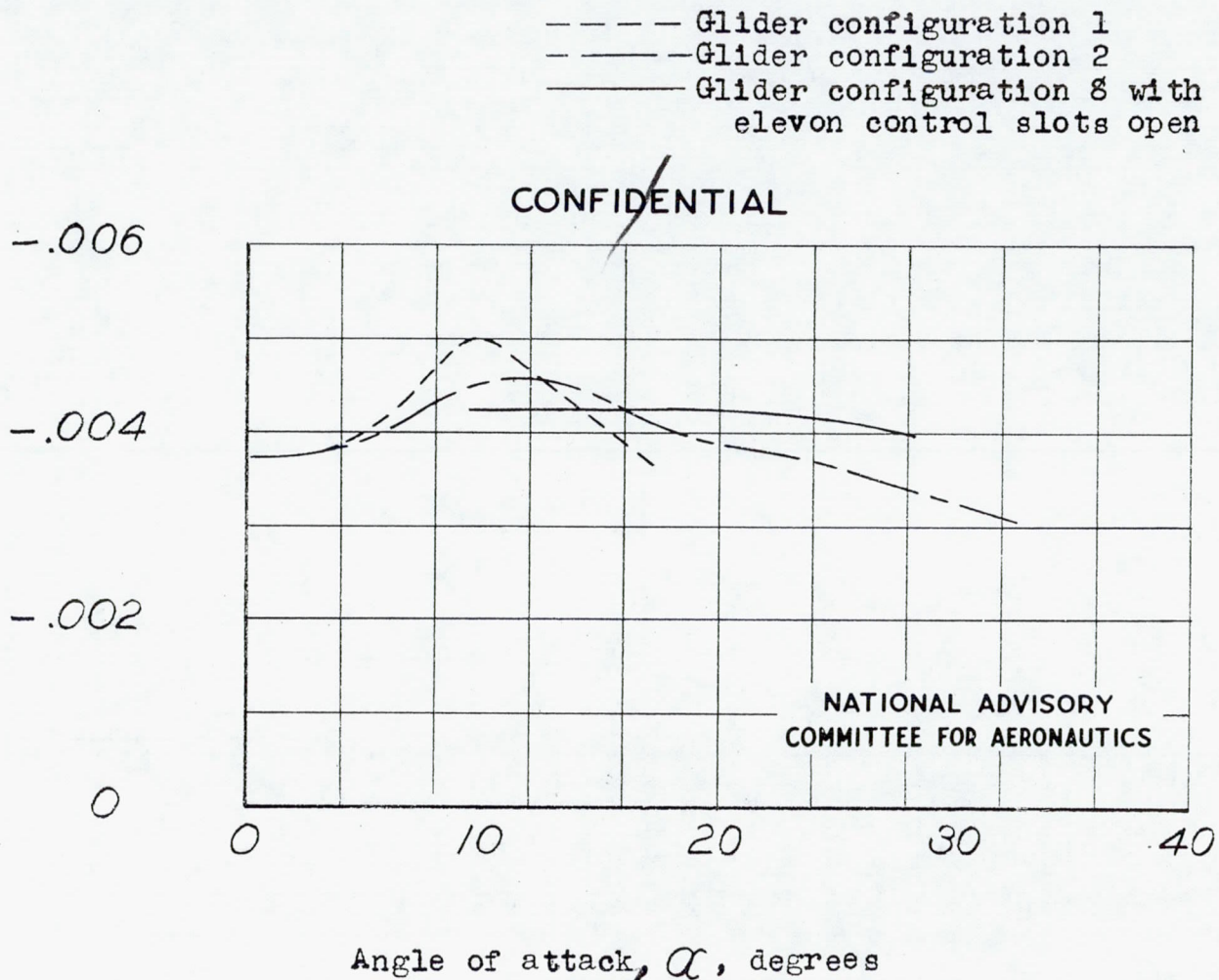

Figure 7 .- Variation of elevator effectiveness with angle of attack for DM-1 glider configurations 1, 2 , and 3.

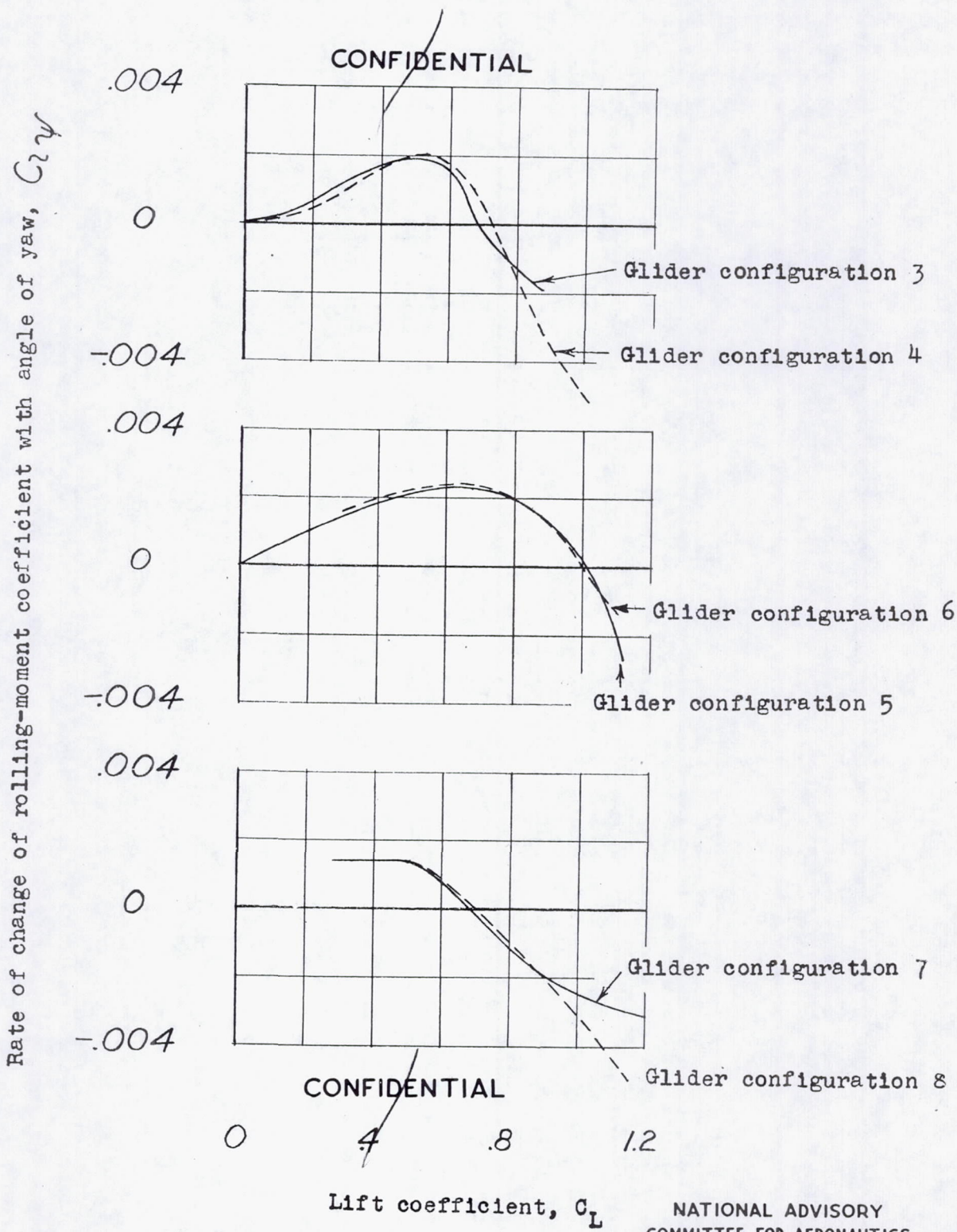
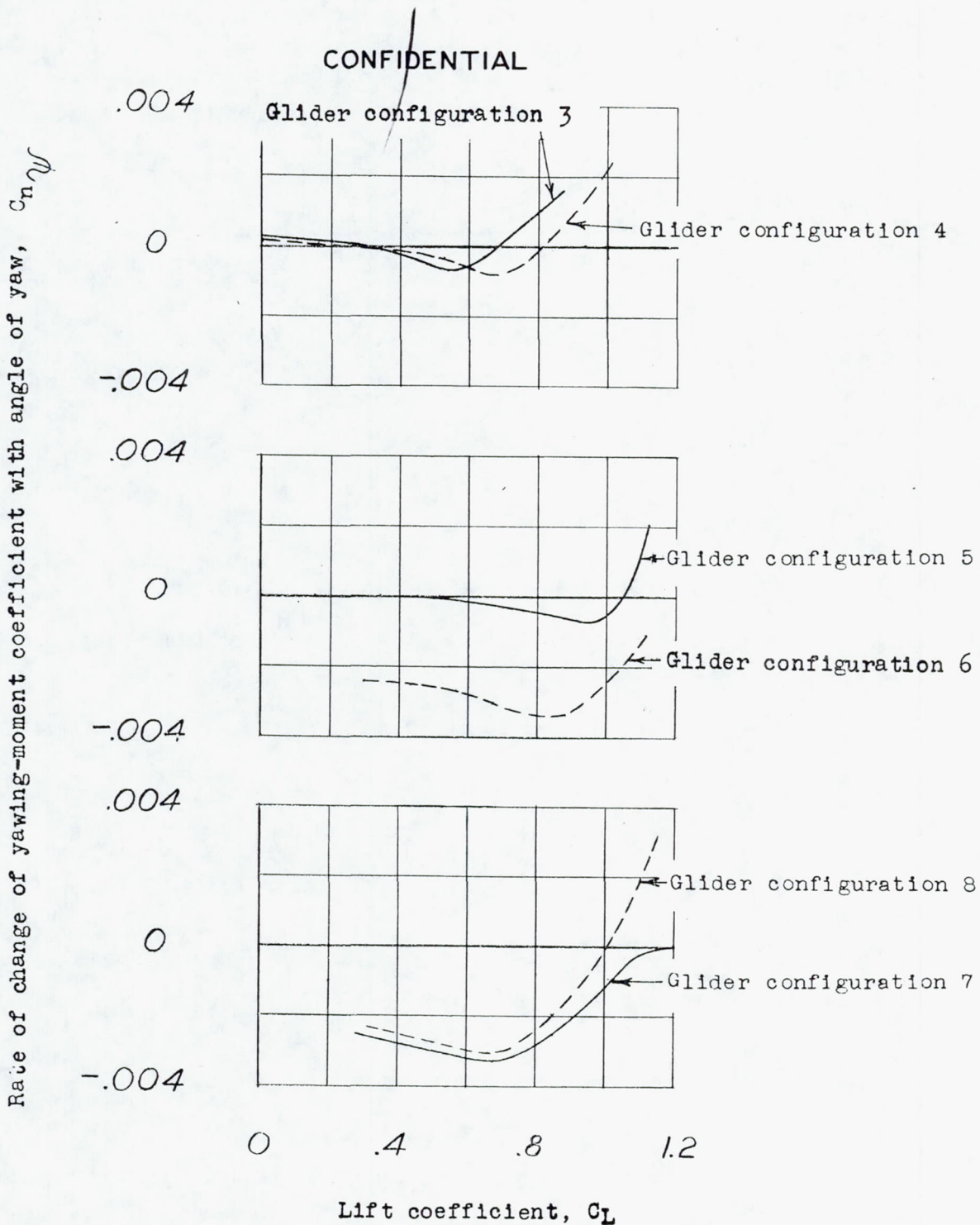
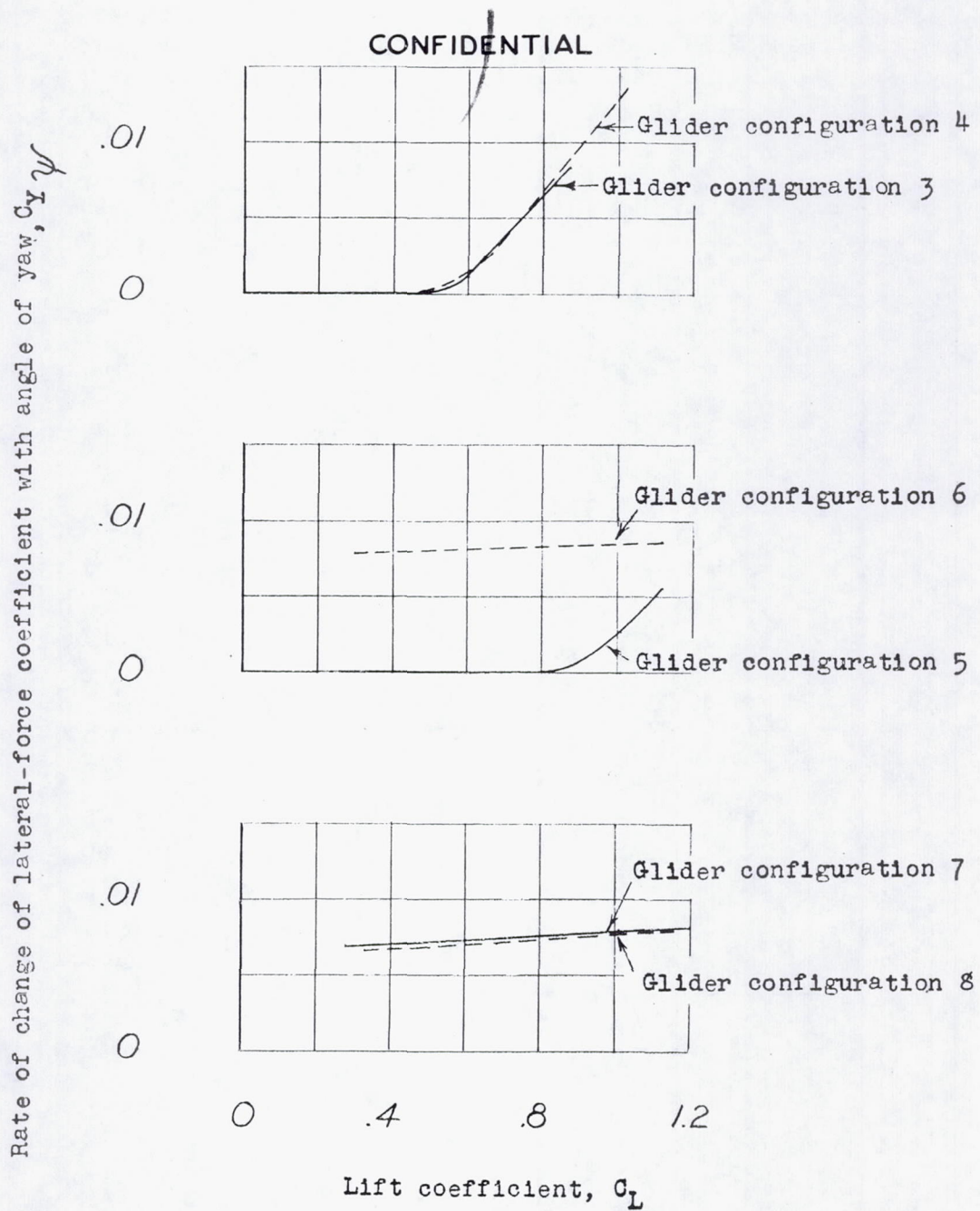

Figure 8 .- Effect of the modifications made to the DM-1 glider on the lateral-stability parameter $C_{l\psi}$.



NATIONAL ADVISORY
COMMITTEE FOR AERONAUTICS

Figure 9 .- Effect of the modifications made to the DM-1 glider on the directional-stability parameter $C_{n\psi}$.



CONFIDENTIAL

NATIONAL ADVISORY
COMMITTEE FOR AERONAUTICS

Figure 10.- Effect of the modifications made to the DM-1 glider on the lateral-force parameter $C_{y\psi}$.

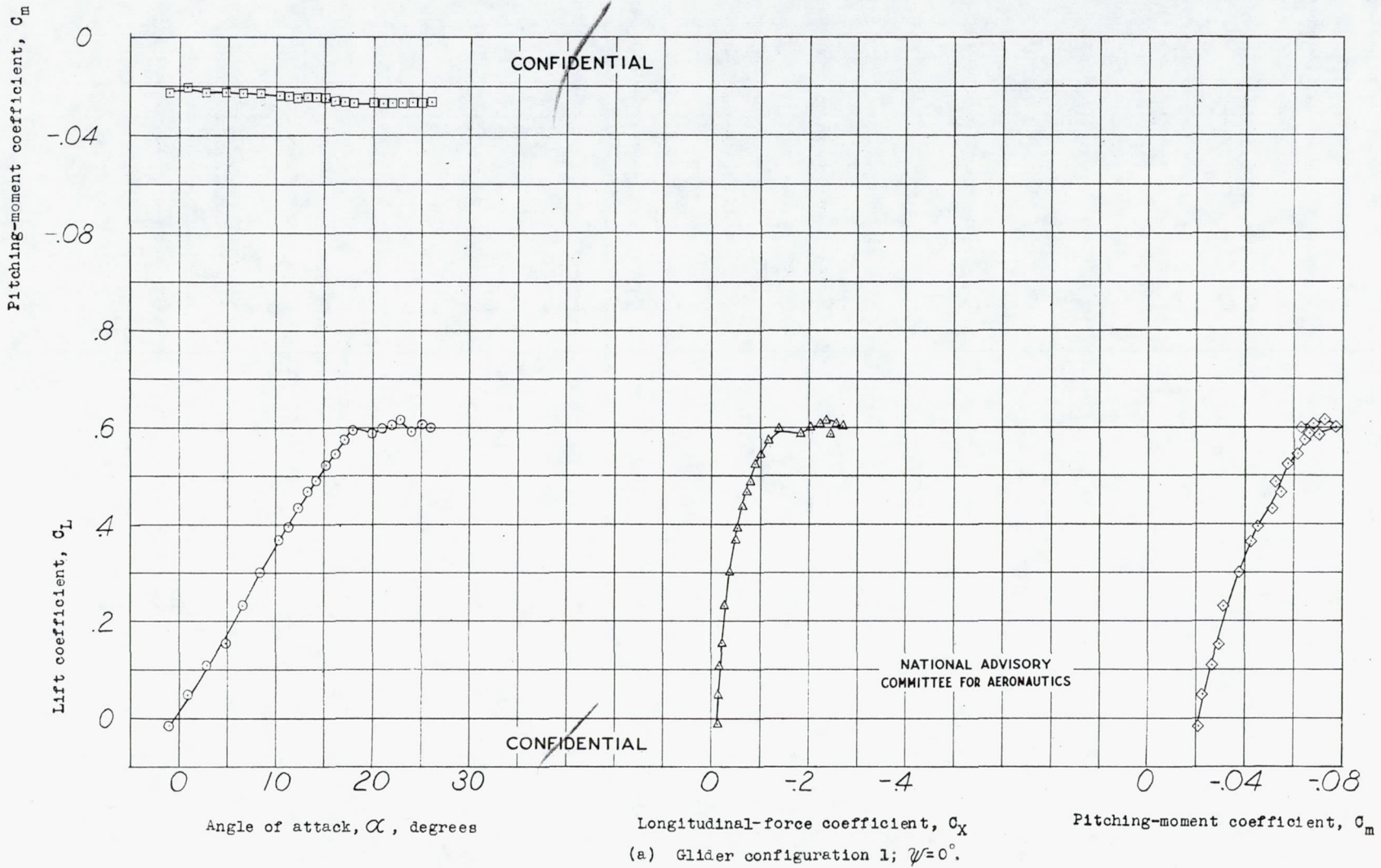

Figure//.- Aerodynamic characteristics of the DM-1 glider with controls neutral.

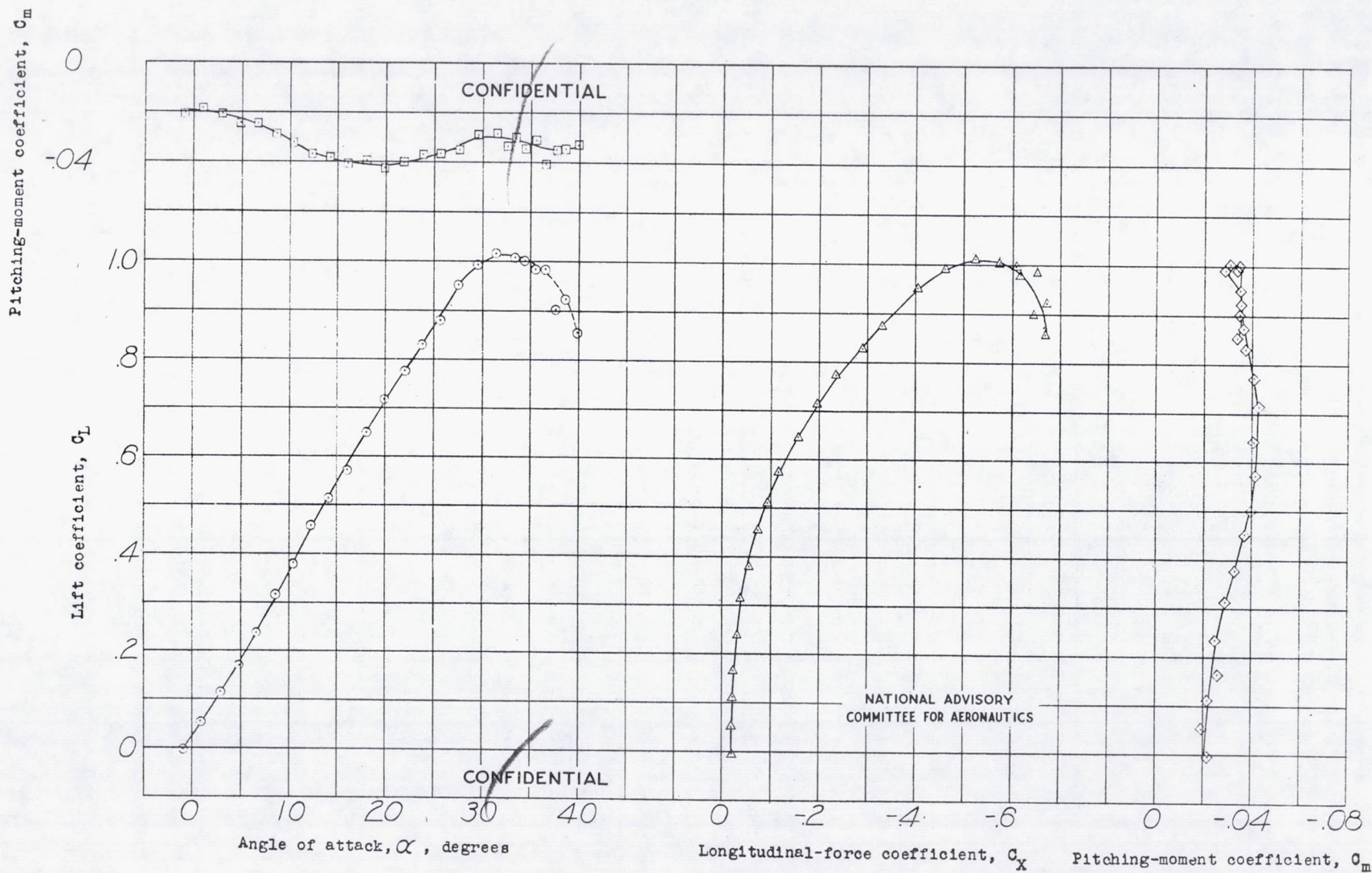

Figure // .- Continued.

(b) Glider configuration 2; $\psi = 0^\circ$.

Fig. 11b

CONFIDENTIAL

Longitudinal-force coefficient, C_x

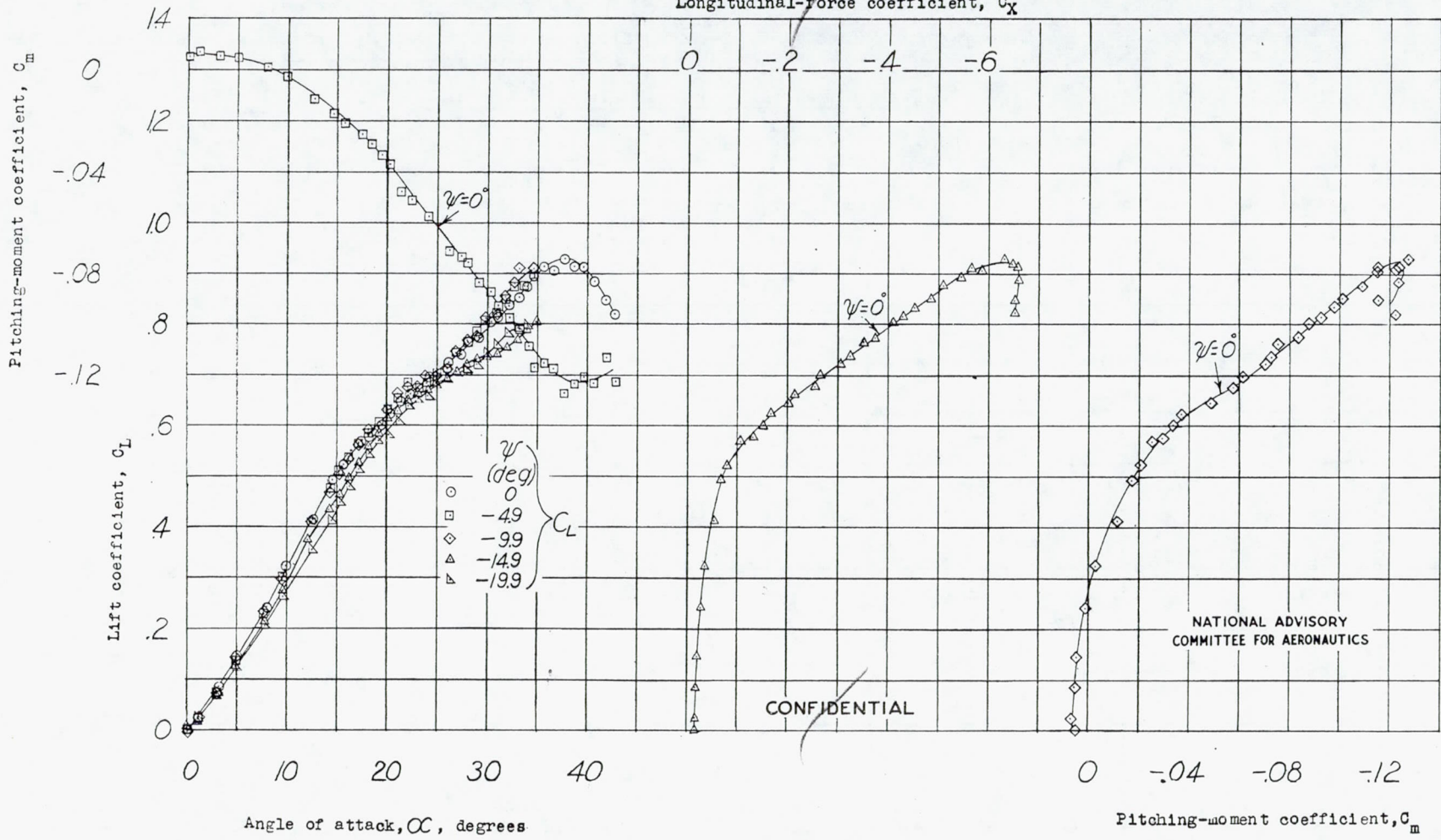

(c) Glider configuration 3.

Figure // .- Continued.

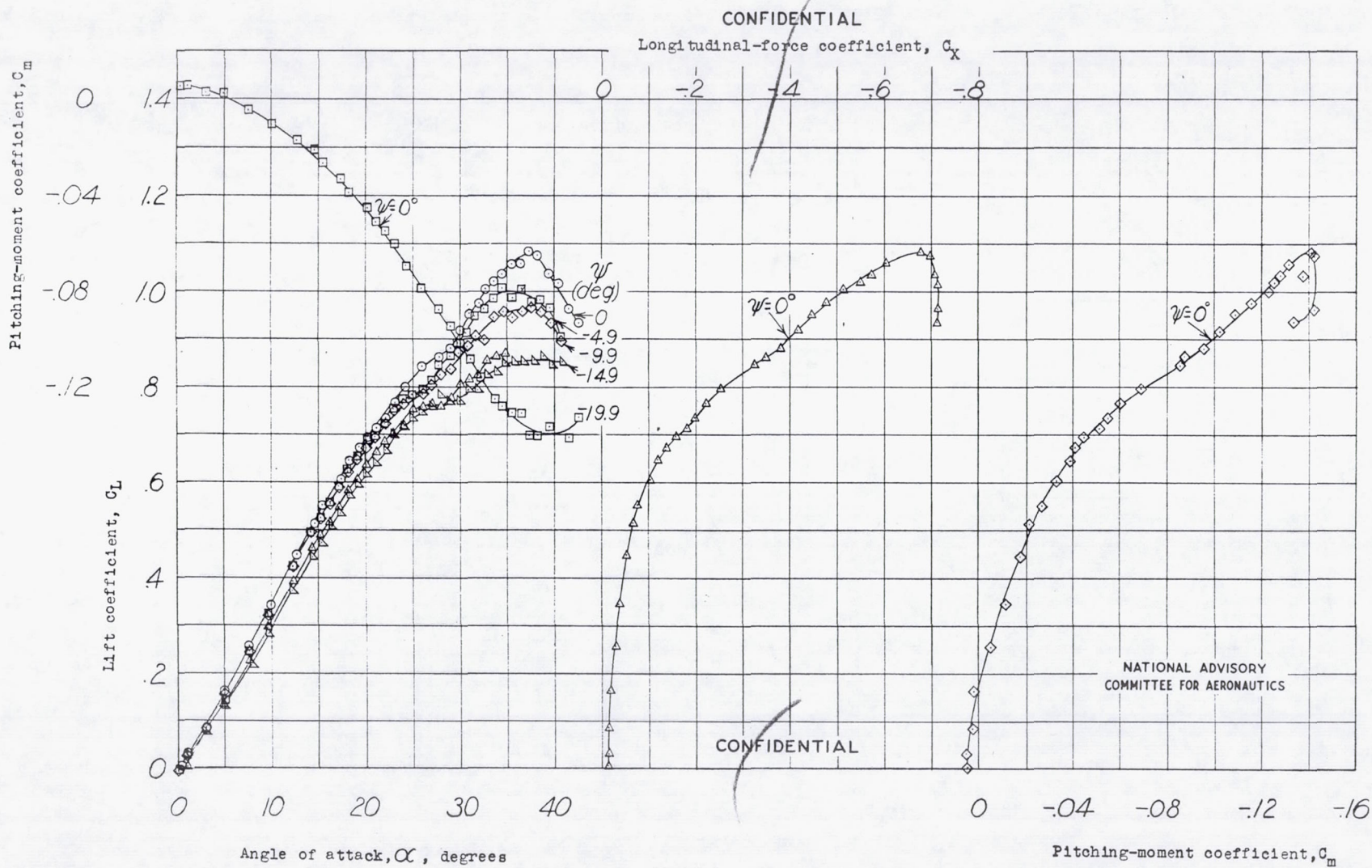

(d) Glider configuration 4.

Figure// -- Continued.

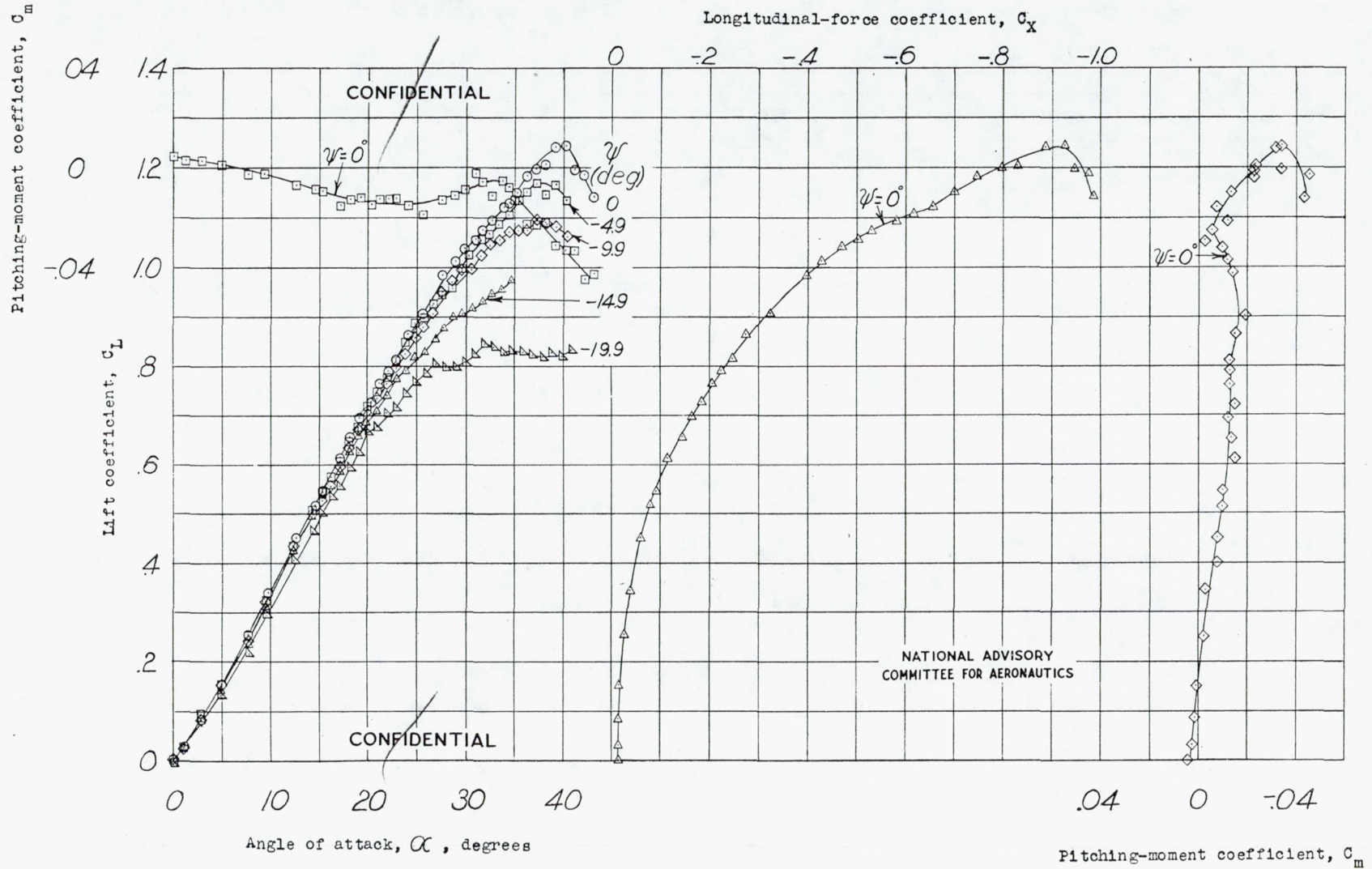

(e) Glider configuration 5.

Figure //.- Continued.

CONFIDENTIAL
Longitudinal-force coefficient, C_x

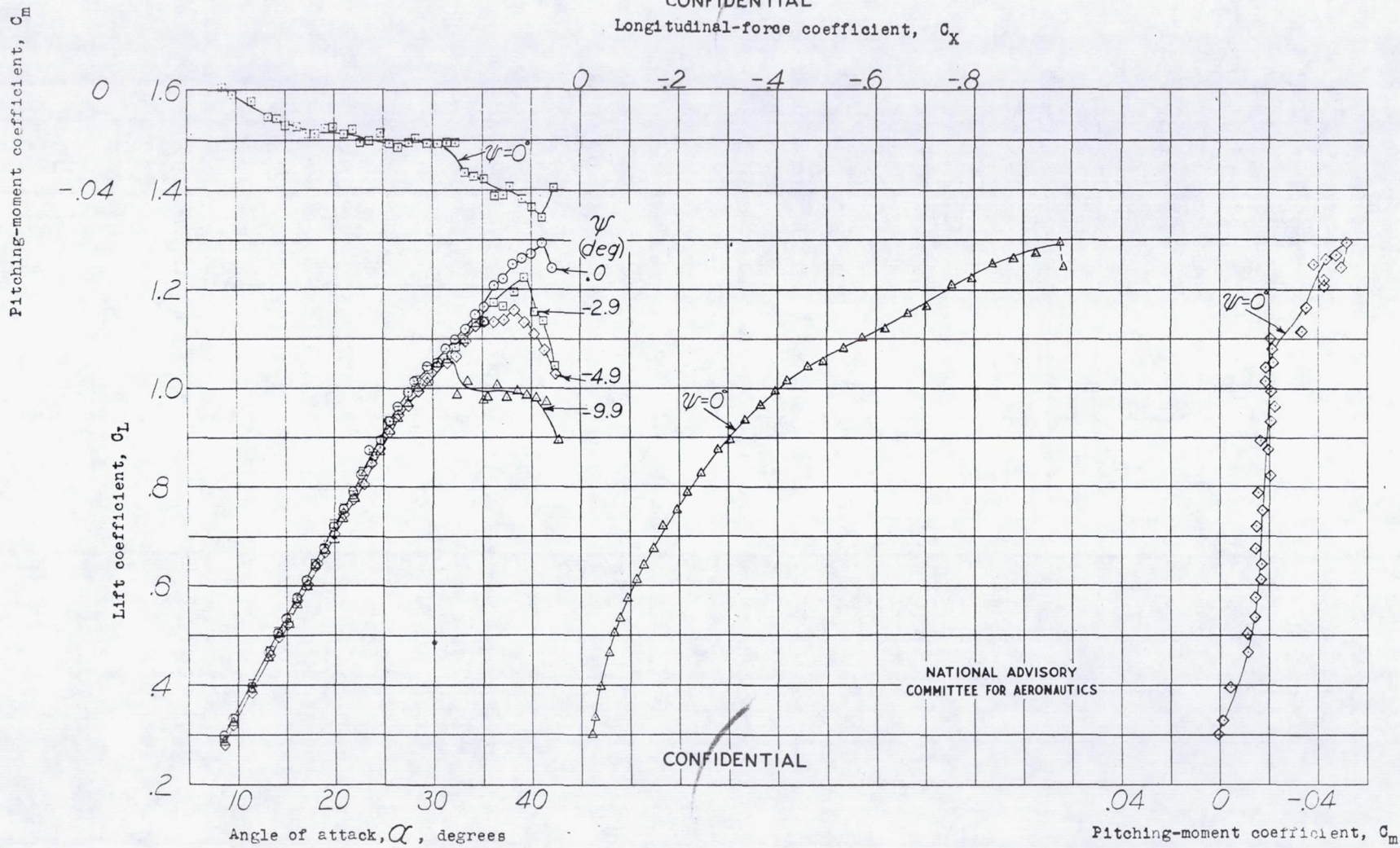

(f) Glider configuration 6.

Figure //.- Continued.

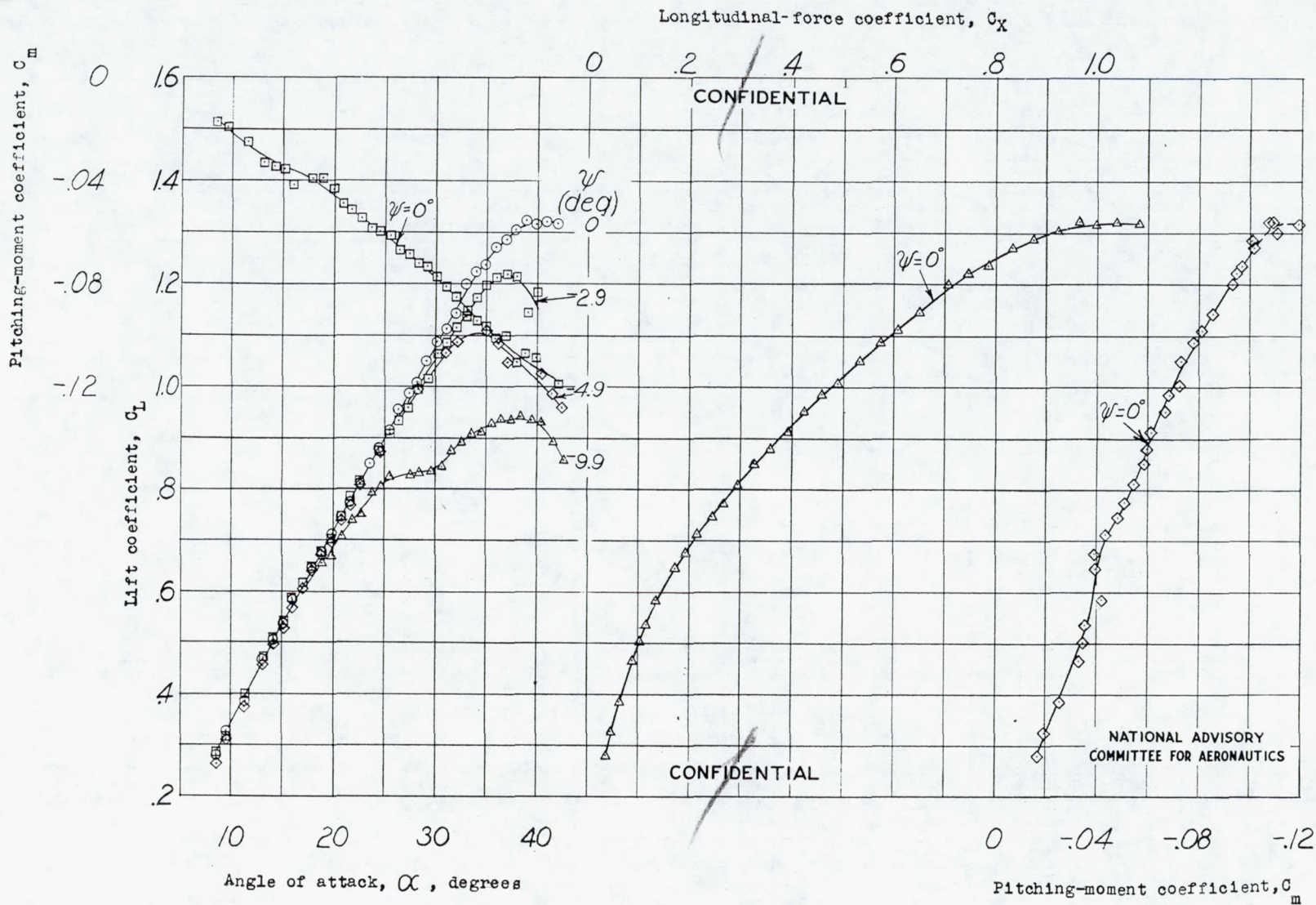

(g) Glider configuration 7.

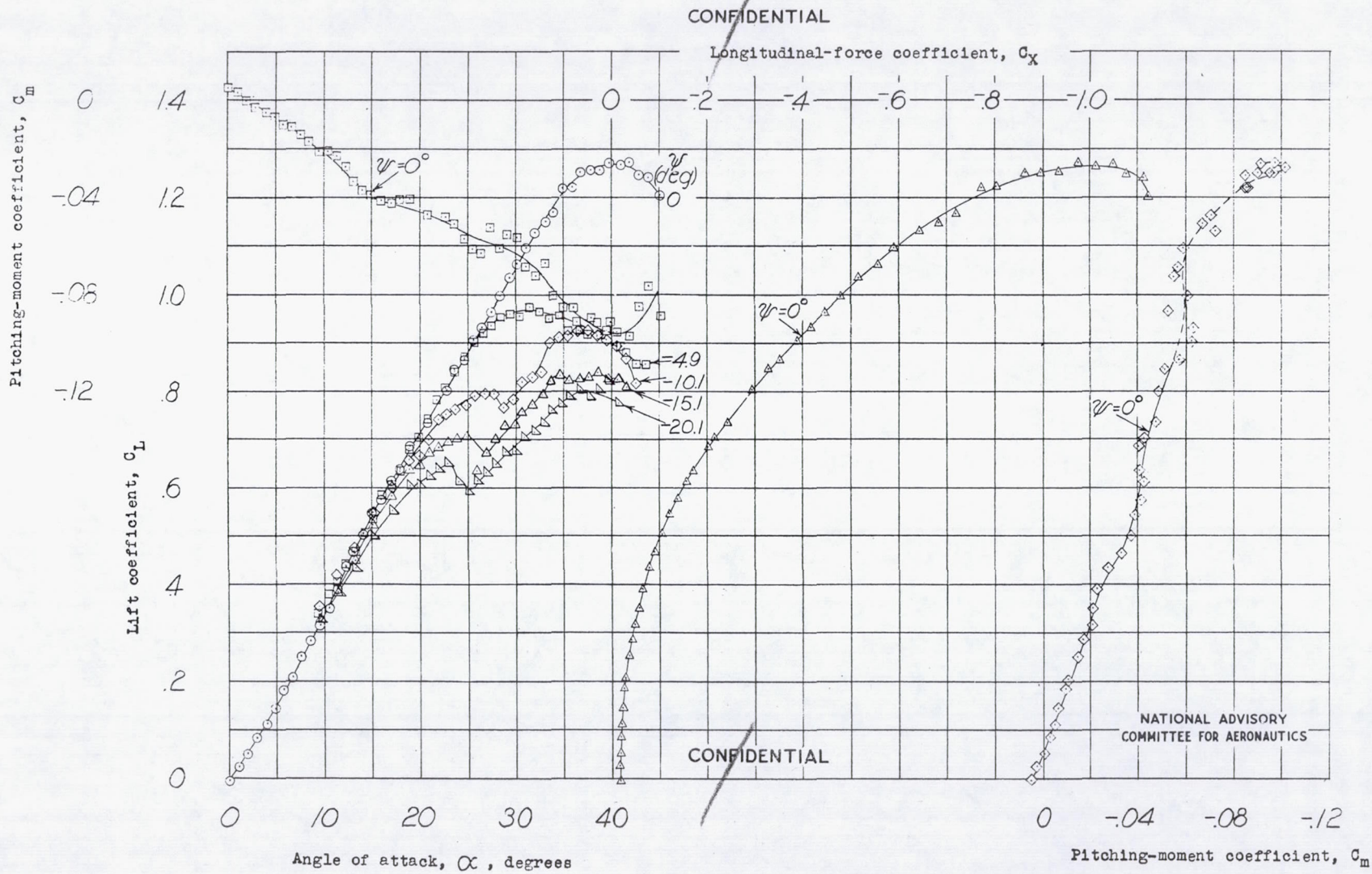

(h) Glider configuration 8.

Figure // .- Concluded.

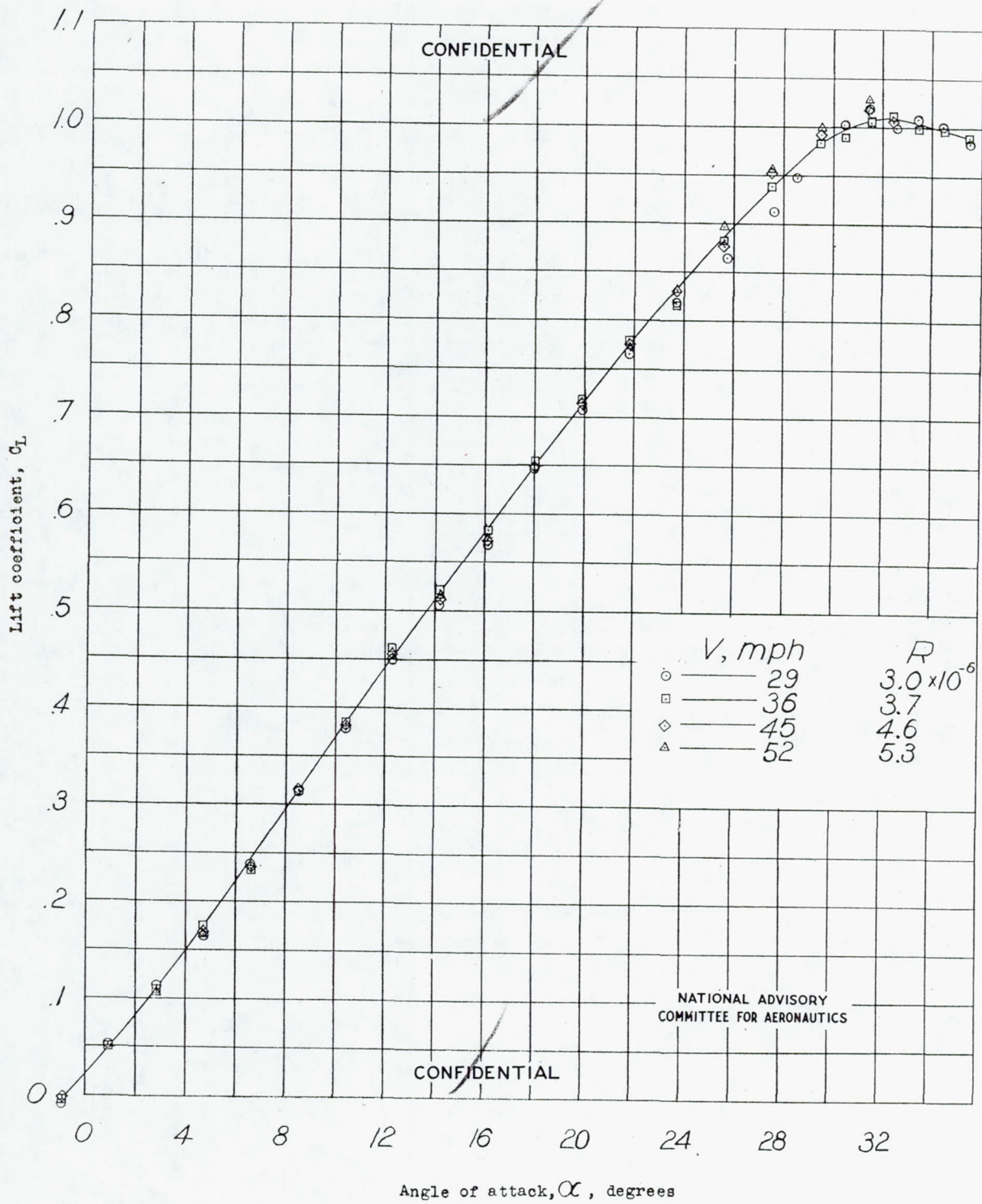
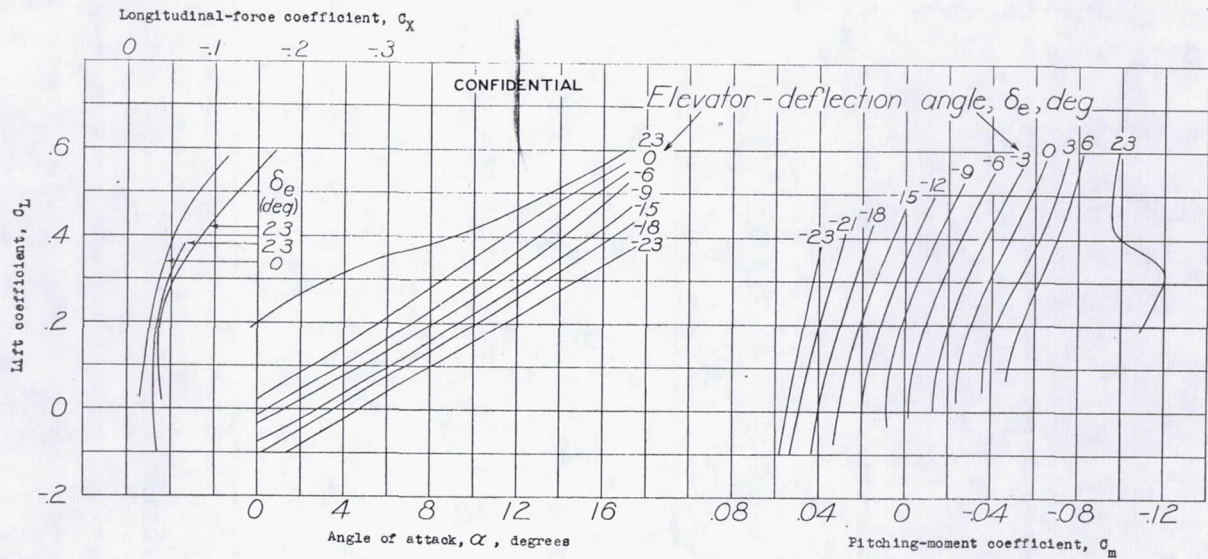
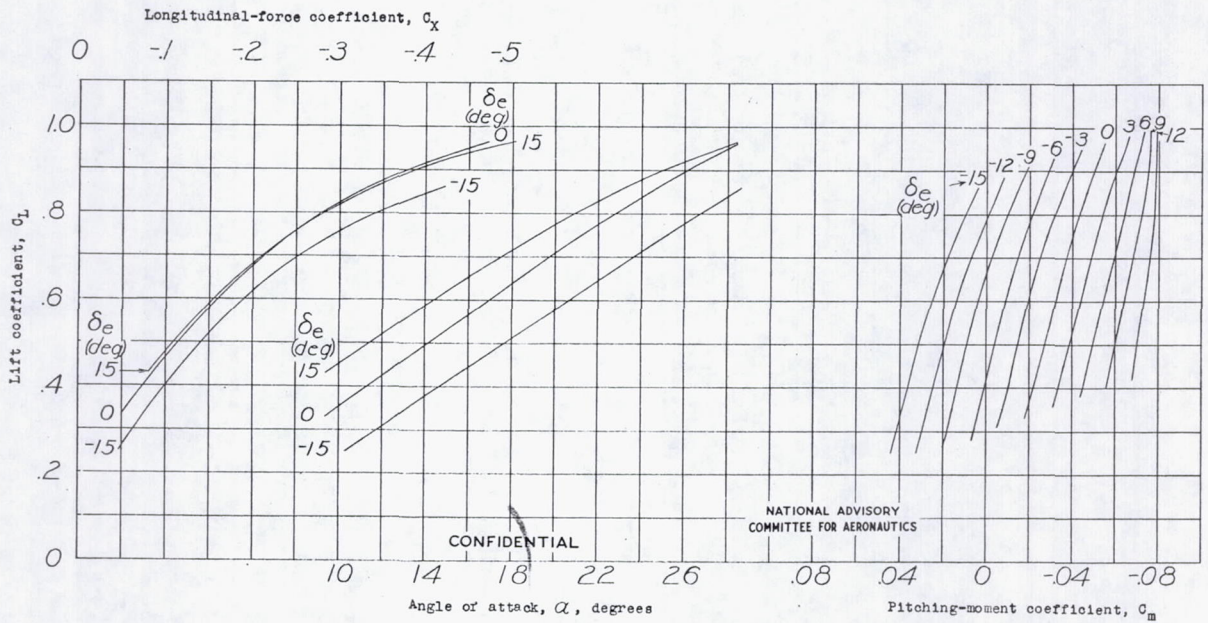

Figure 12 .- Effect of tunnel airspeed on lift coefficient for the DM-1 glider. Configuration 2.



(a) Glider configuration 1.



(b) Glider configuration 8 with elevon control-balance slots open.

Figure 13.- Effect of elevator deflection on the aerodynamic characteristics of the DM-1 glider. $\delta_e=0^\circ$.

Fig. 14

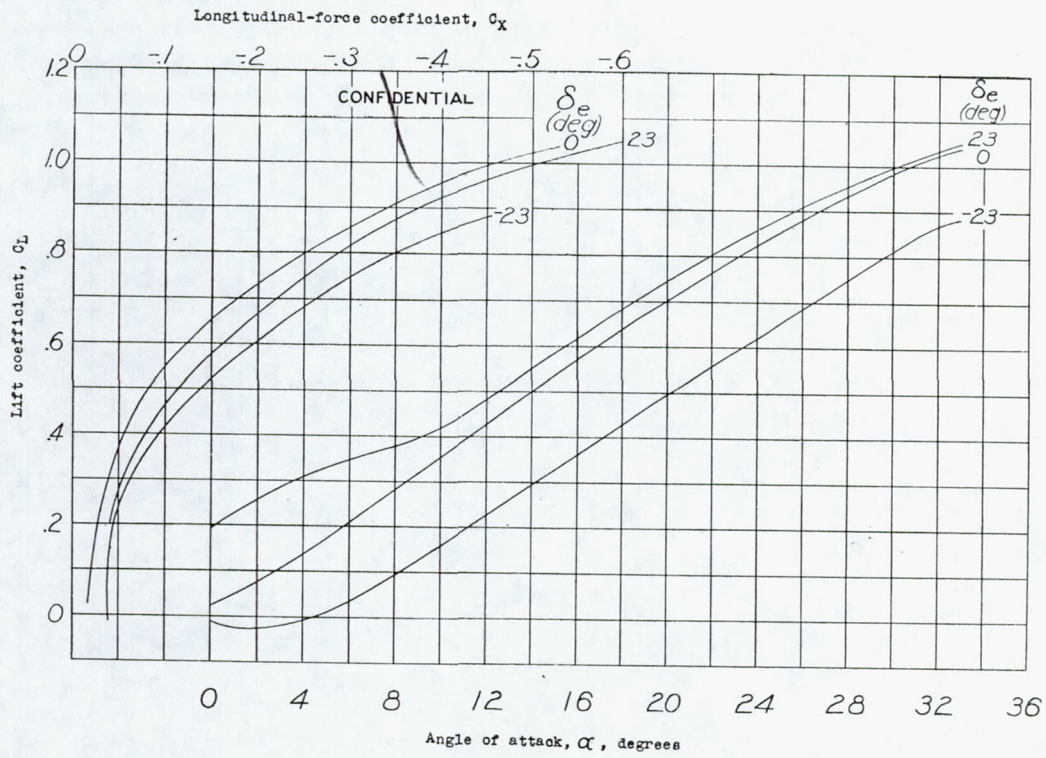

(a) Variation with C_L of C_x and α .

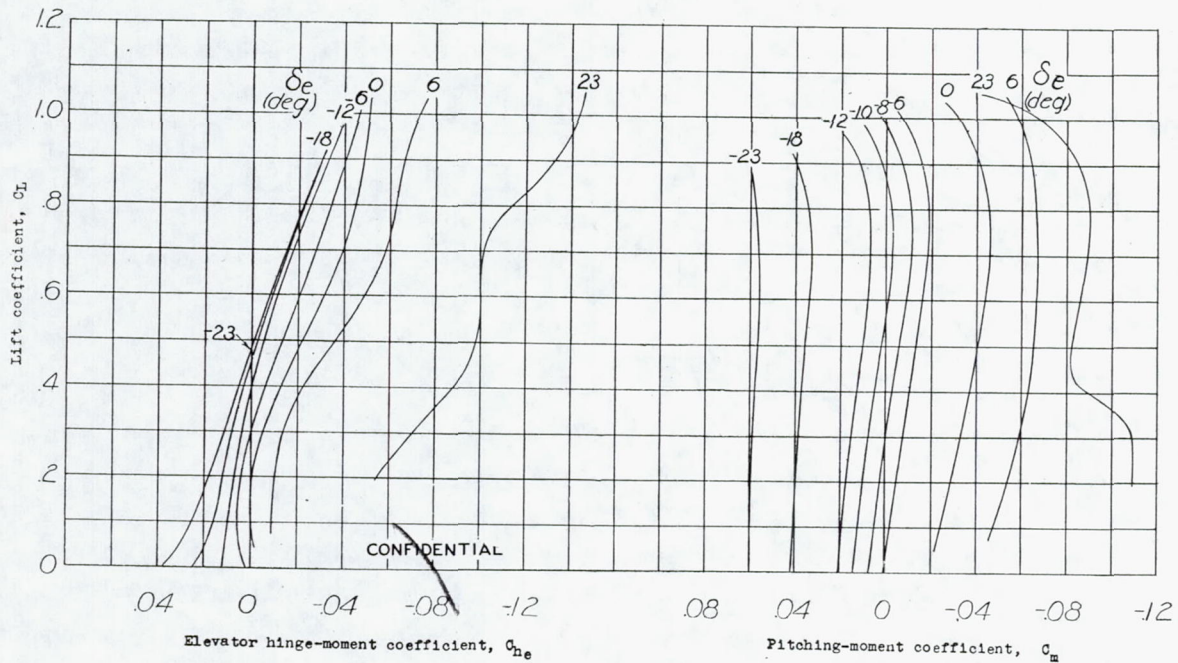

(b) Variation with C_L of C_m and C_{he} .

NATIONAL ADVISORY
COMMITTEE FOR AERONAUTICS

Figure 14.- Effect of elevator deflection on the aerodynamic characteristics of the DM-1 glider. Configuration 2; $\psi = 0^\circ$.

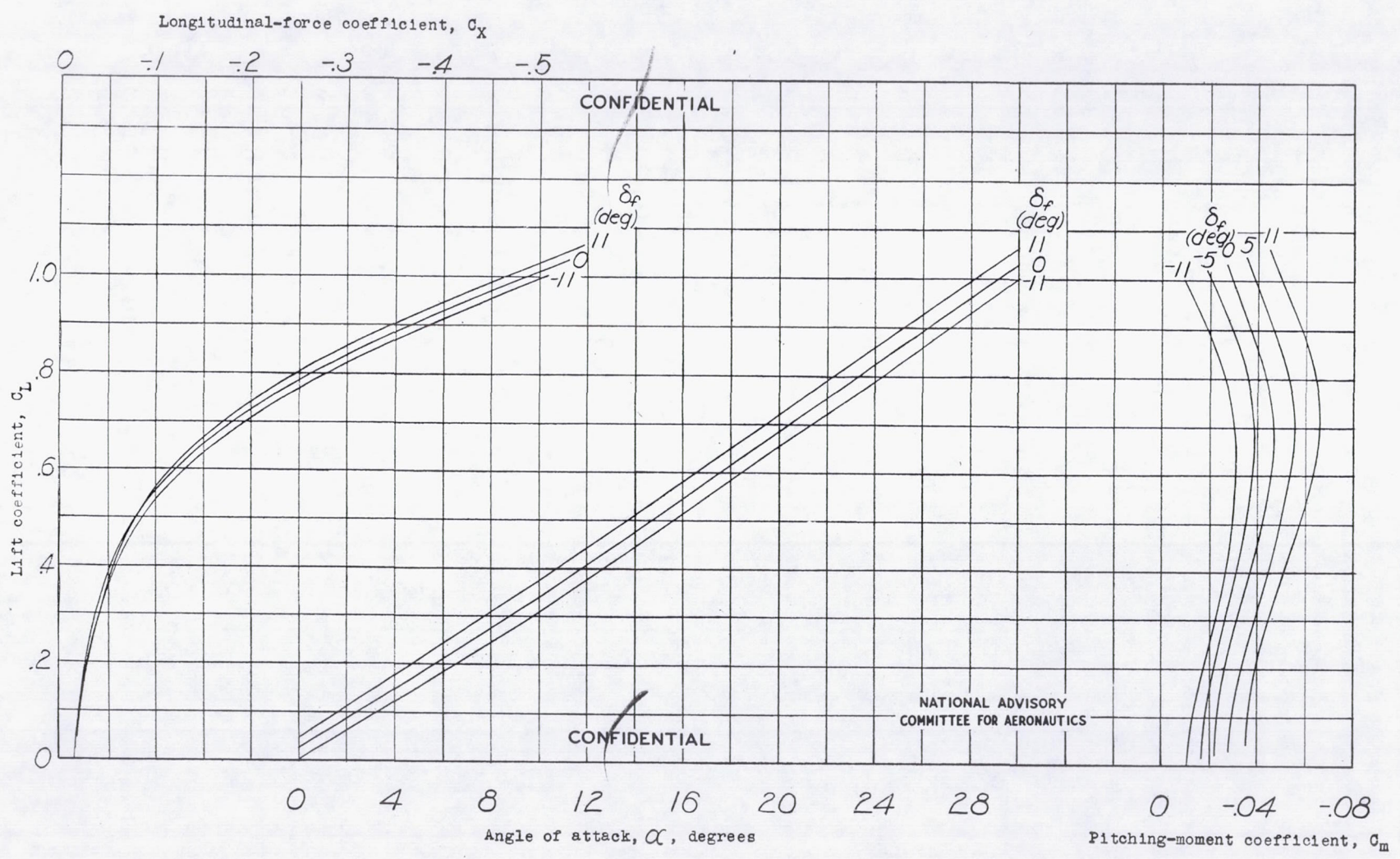

Figure 15.- Effect of trim-flap deflection on the aerodynamic characteristics of the DM-1 glider. Configuration 2; $\psi = 0^\circ$.

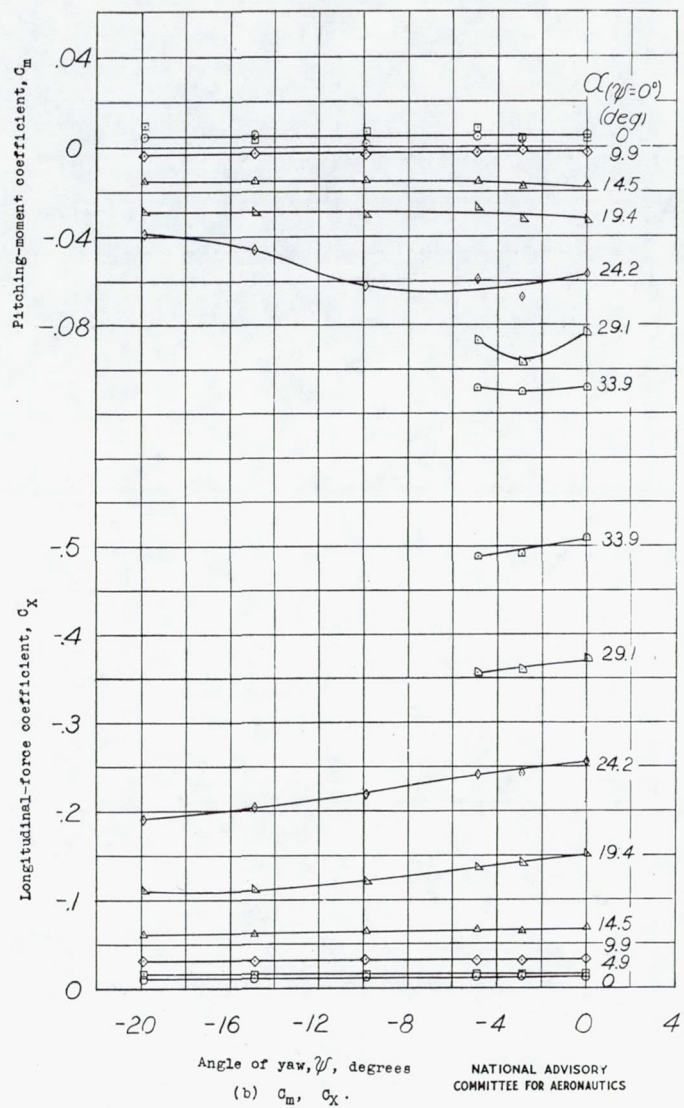
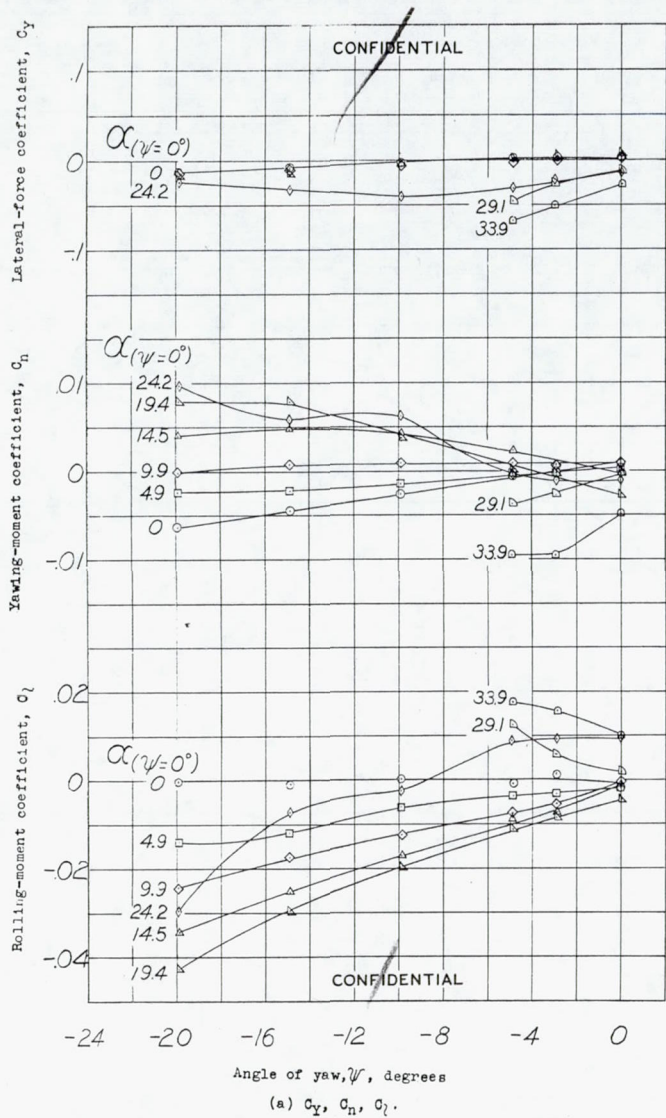

Figure 16.- Effect of yaw on the aerodynamic characteristics of the DM-1 glider. Configuration 3; $\delta_a = 0^\circ$.

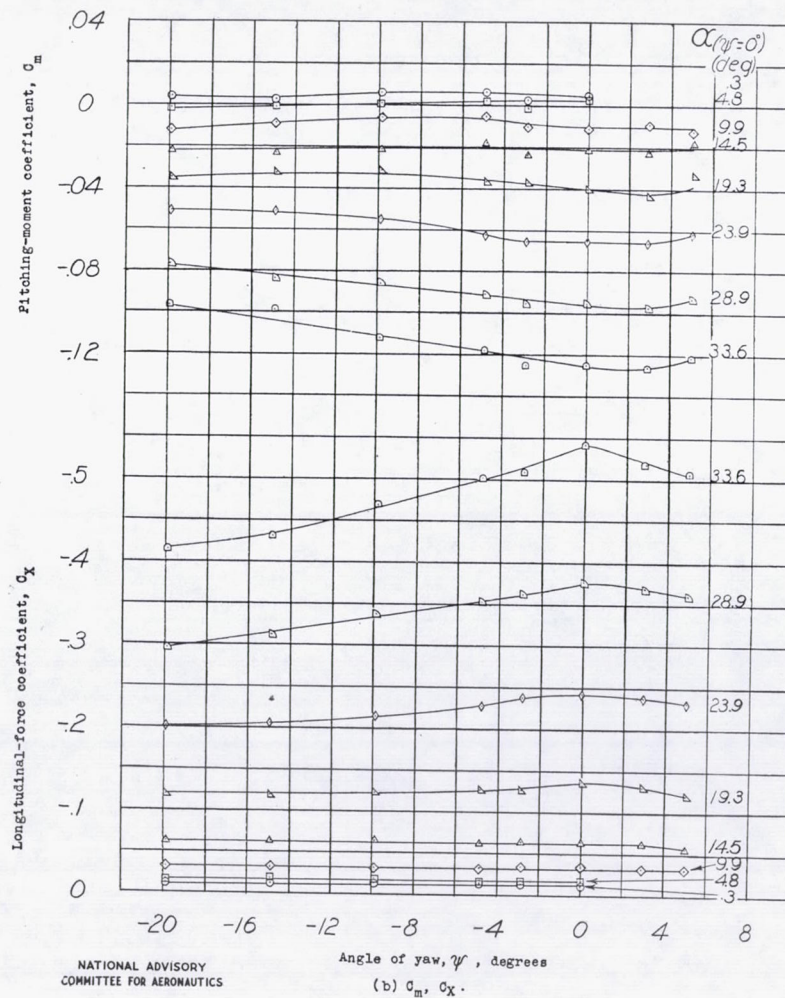
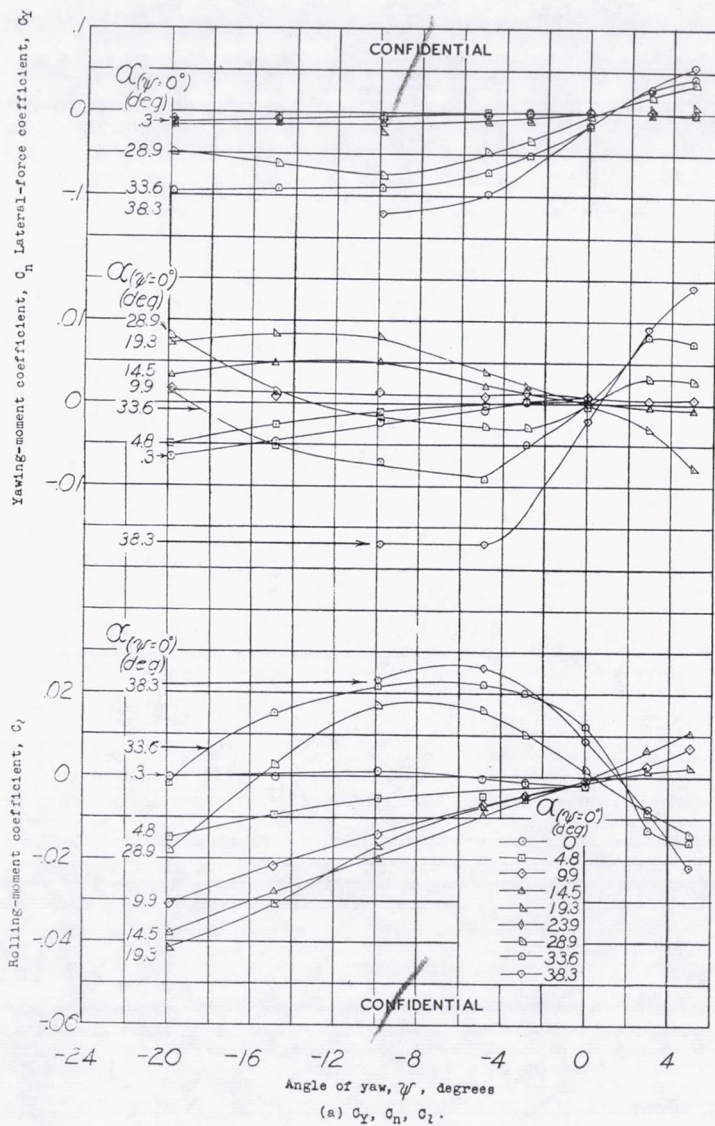

Figure 7.- Effect of yaw on the aerodynamic characteristics of the DM-1 glider. Configuration 4 ; $\delta_a = 0^\circ$.

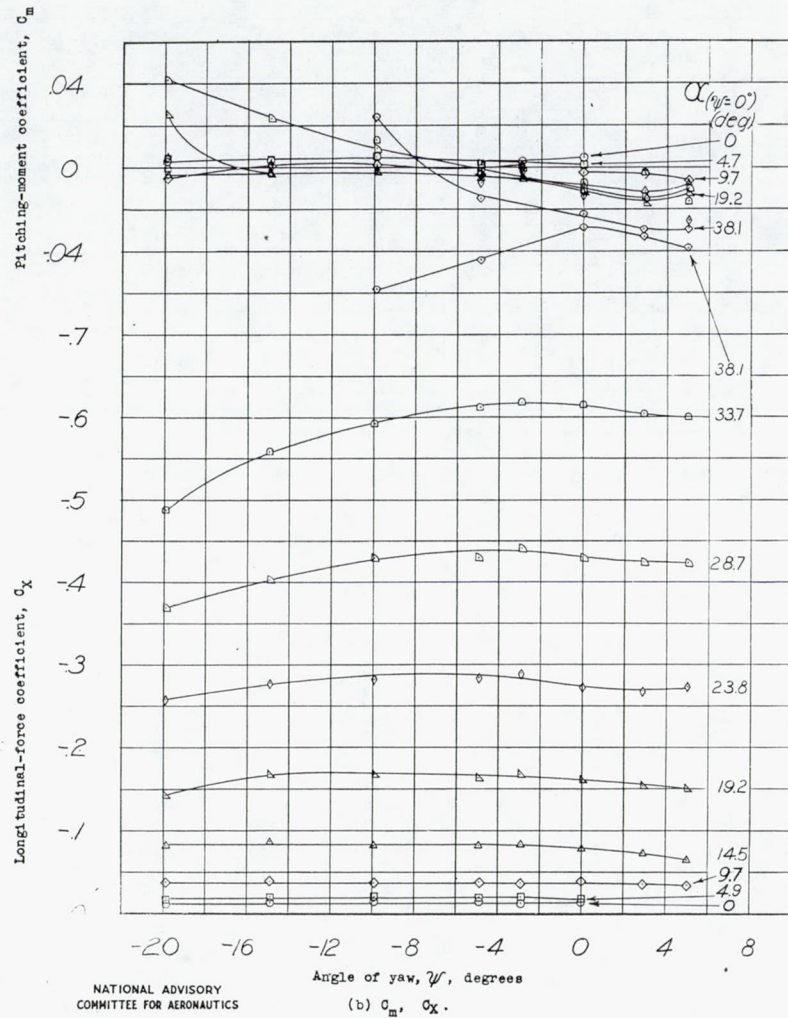
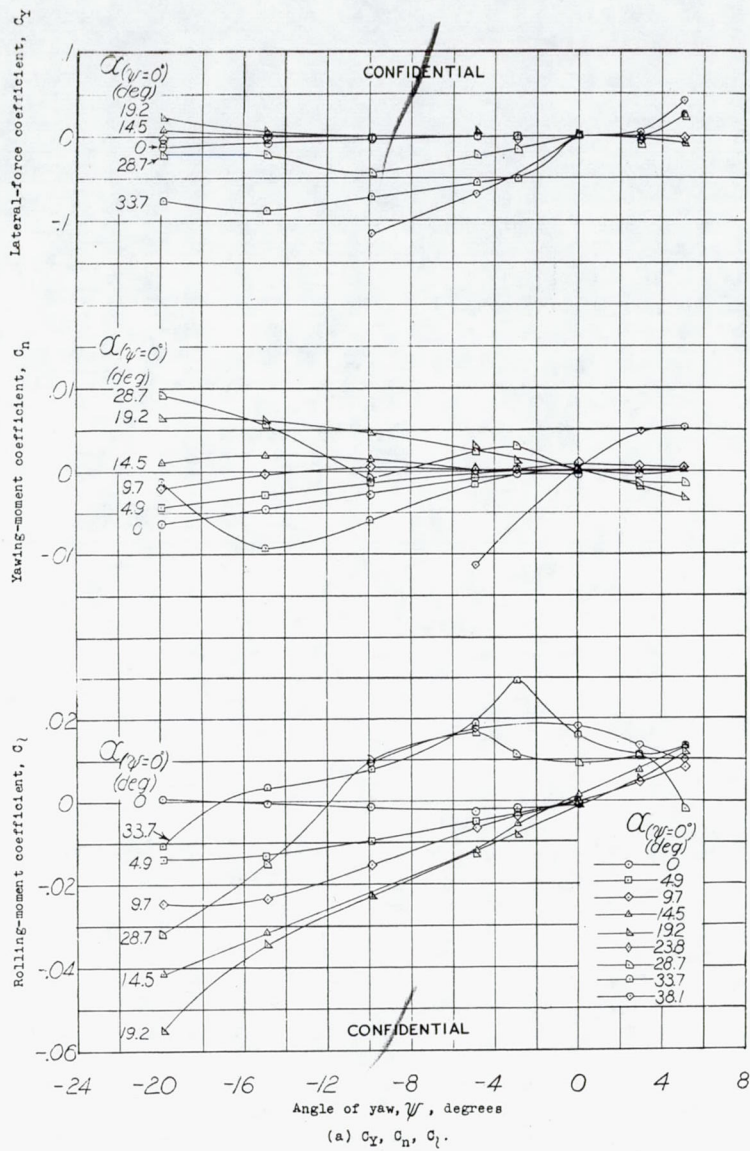

Figure 18.- Effect of yaw on the aerodynamic characteristics of the DM-1 glider. Configuration 5; $\delta_e = 0^\circ$.

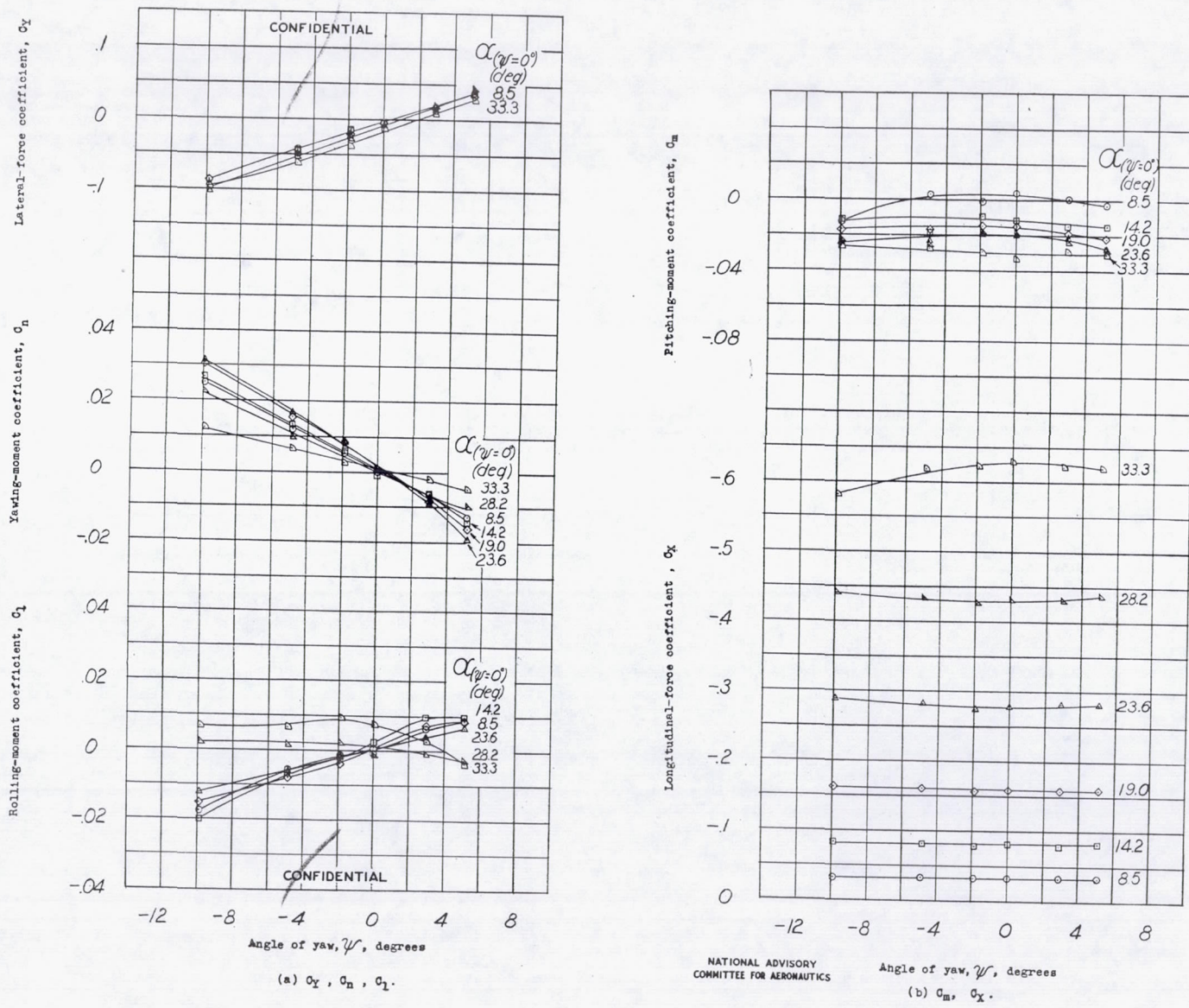

Figure 9.- Effect of yaw on the aerodynamic characteristics of the DM-1 glider. Configuration 6; $\delta_e = 0^\circ$.

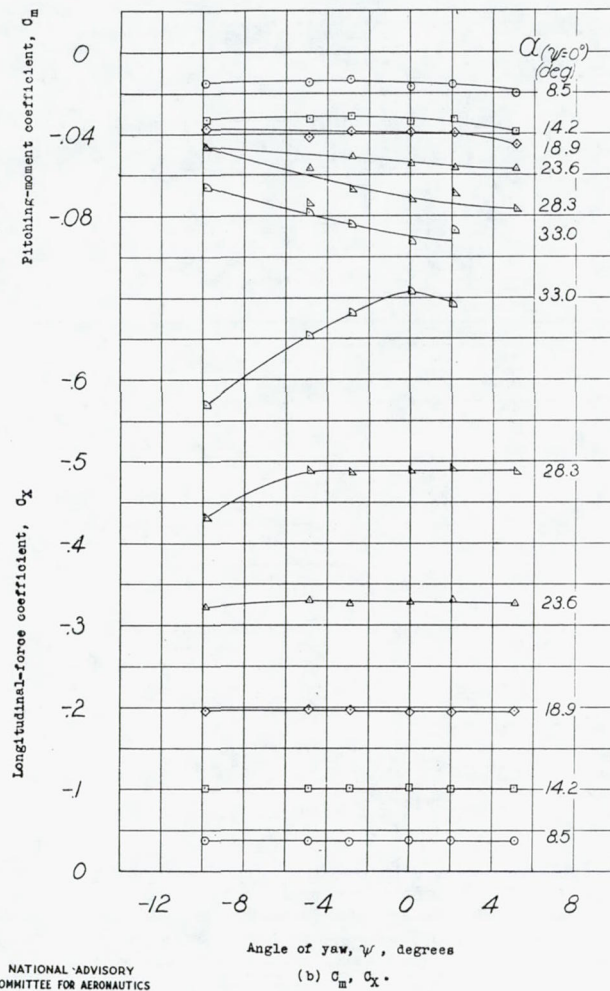
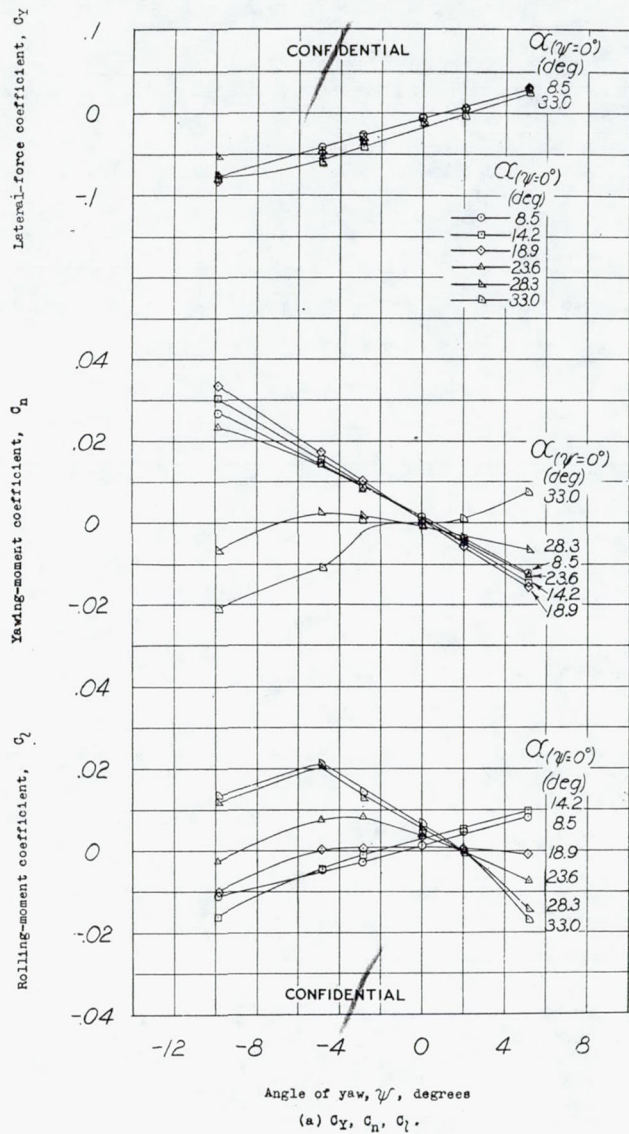

Figure 20.- Effect of yaw on the aerodynamic characteristics of the DM-1 glider. Configuration 7; $\delta_c=0^\circ$.

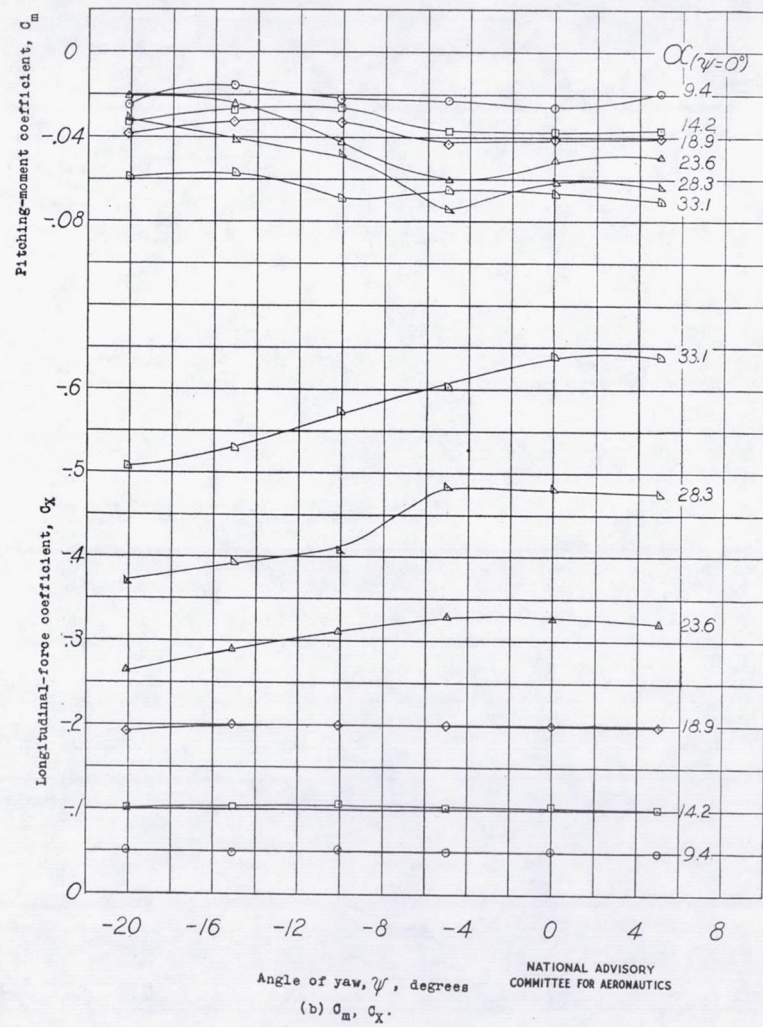
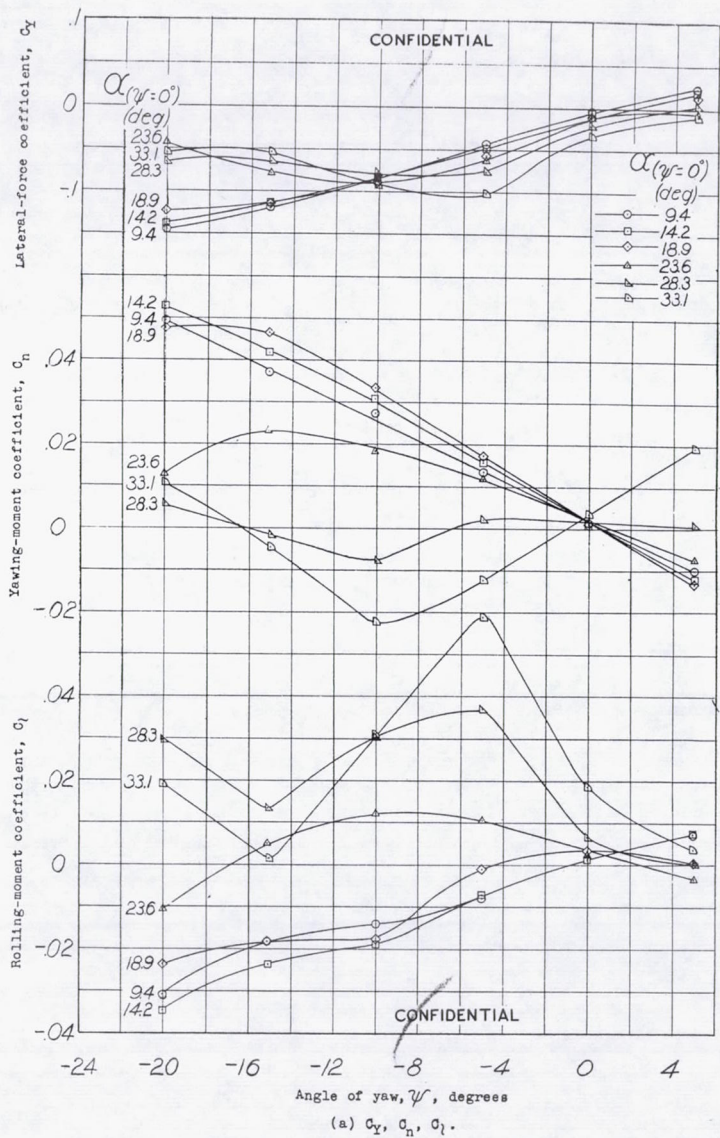

Figure 21.- Effect of yaw on the aerodynamic characteristics of the DM-1 glider. Configuration 8; $\delta_e = 0^\circ$.

