

TECHNICAL MEMORANDUMS  
NATIONAL ADVISORY COMMITTEE FOR AERONAUTICS

---

No. 628

---

FIRE PREVENTION ON AIRCRAFT

By Fritz Kühn

Zeitschrift für Flugtechnik und Motorluftschiffahrt  
Vol. 22, Nos. 7 and 8, April 14 and 28, 1931  
Verlag von R. Oldenbourg, München und Berlin

---

Washington  
July, 1931

NATIONAL ADVISORY COMMITTEE FOR AERONAUTICS

TECHNICAL MEMORANDUM NO. 628

FIRE PREVENTION ON AIRCRAFT\*

By Fritz Kühn

I. INTRODUCTION

The question of increasing the safety of airplanes by reducing the fire hazards is one of the most important problems in the designing of aircraft and aircraft engines, as also for the further development of air traffic.

So long as only light-oil or carburetor engines are available for aircraft, there will always be danger of fire due to the inflammability of the light fuels. This is also true of airship engines using power gas. It is of secondary importance as to how the fuel is conducted to the engine cylinders during operation. Since fuel and oil must be located somewhere on the aircraft, fire can be easily started and spread by them. This possibility will likewise continue to exist in the use of heavy-oil engines (high-pressure and low-pressure Diesel engines) on aircraft. The fire hazards will be considerably reduced, however, due to the lower inflammability of the fuel.

We must consider not only the danger of fire from the liquid fuel, but also the danger of explosion from the mixture of fuel and air. Such explosive mixtures are always liable to form under the engine cowling or in the tank compartments due to leaks in the fuel system. Under certain conditions this is particularly liable to happen with ether, gasoline and benzol (benzene). Explosive mixtures form less readily with heavy oils than with light oils. The chances of the formation of explosive mixtures from the evaporation of lubricating oils are about the same as for heavy fuel oils.

The following discussion is at first restricted to the light-oil engines now in use. We shall consider how far it

---

\*"Erhöhung der Sicherheit von Luftfahrzeugen durch Bekämpfung der Brandgefahr." From Zeitschrift für Flugtechnik und Motorluftschiffahrt, published by R. Oldenbourg, Munich and Berlin, April 14, 1931, pp. 197-206, and April 28, 1931, pp. 241-244.

is possible to reduce the fire hazards by changes in the design of the engines and carburetors and in the arrangement of the fuel pipes.

The development of aircraft and aircraft engines has shown that, aside from the magnetos which are essential in light-oil engines, more and more electrical apparatus is required, partly for lighting and radio and partly for the operation of recording instruments, etc. These constitute additional fire hazards, especially in the event of a short circuit or break. The use of electrical apparatus, however, will probably continue to increase.

Fire may also be caused by lightning, though this is very seldom. On commercial aircraft allowance must also be made for the carelessness of the passengers (smoking in the cabin when no special smoking compartment is provided). Moreover, the fire hazards are greatly increased on airships by the use of hydrogen as the lifting gas. Helium should be used whenever possible.

From the foregoing it is obvious that fire hazards still exist on aircraft. They can however be greatly reduced. We shall consider all the known and possible causes of fire and the best form and arrangement of that part of the equipment designed for its prevention and extinction. This investigation is based on accident statistics and experimental data. Figure 1 represents graphically the aircraft-fire statistics for the period of 1926 to 1929. The accidents involving fire constituted only about 2% of the whole number of accidents.

## II. CAUSES OF FIRE

### In the Air

On an aircraft in flight various causes may start a fire, which spreads rapidly when there is fuel at hand. Food for a fire that has once been started is always present under the engine cowling, even with the very best care and ventilation, in the form of drops of fuel and oil and even, under some conditions, in the form of an explosive mixture of fuel and air. Oil almost always collects in the cowling and on the engine while the latter is running. Fuel always collects in the vicinity of leaky joints. It may also happen that fuel or oil from loose connections may penetrate the engine space in the form of a fine spray, since most of the fuel and oil pipes are under compression.

More dangerous still is the collection of large quantities of fuel in the engine cowling from a leaky carburetor or fuel pump, which are generally inside the cowling, or from the rupture of a fuel or oil pipe. An explosive mixture of fuel and air may then be very quickly formed under the hood. The entire space inside the engine cowling can be filled with flames in a very short time. Such a fire is very serious and can be extinguished only by the most powerful means.

Since fuel and oil are always present inside the engine cowling, it only requires a spark, an open flame, or simply the contact of the liquid with a hot part of the engine, to start a fire. The danger from an open flame usually in the form of so-called "back fires," is often underestimated. As soon as they notice fire or smoke, many pilots, on the assumption that it comes from the carburetor, immediately open the throttle wide while simultaneously closing the fire cock, so that the flames will be drawn back into the cylinders by the greater negative pressure. Carburetor fires have often been extinguished in this manner. This method can not be recommended however and should generally be avoided. It should be employed only in an emergency where there is no other way to combat the fire.

Back-firing may result from any of the following causes:

- a) Failure of camshaft;
- b) Failure of control lever (seizing at bearing point);
- c) Failure of a valve;
- d) Foreign substances between valve head and seat, e.g., in the failure of a piston pin or connecting rod or in the seizing of a piston when the crumbled pieces prevent the valve from closing tightly;
- e) Too rich or too poor fuel mixture;
- f) Poor mixing due to cold engine or insufficient preliminary heating;
- g) Leaky heating device, making it possible for the exhaust flame to ignite the mixture in the intake pipe or even to penetrate into the engine space;
- h) Overheating of the cylinder head or bottom,

through insufficient cooling in air-cooled engines, or perhaps from the formation of steam pockets in water-cooled engines which may cause seizing of the piston.

If the back fire penetrates the carburetor it finds abundant fuel in the float chamber and quickly escapes through small leaks to the outside where the fuel and oil deposits assist the flames to spread further. Moreover, the back-fire flames may pass through one of the air inlets into the engine compartment, especially when the passages through the engine cowling have not been well fitted to the inlet pipes, and the flames are driven back into the engine compartment by the wind. The strength of the back fire increases with the size of the carburetor and with the inside diameter of the inlet pipes.

In the event of a crankshaft or connecting-rod break, a fire can be started by back fires caused by a sudden increase or decrease in the revolution speed of the engine. In this case the flames may find ample nourishment from an easily possible fuel-pipe break, since such injuries are generally accompanied by strong backward shocks. Figure 2 shows the result of an accident in which the rupture of a piston and connecting rod started a fire in the engine compartment. The engine may be suddenly stopped by the seizing of a piston and the piston head may be broken by the force of the explosion. The oil vapors may take fire and penetrate into the engine compartment and there continue to spread. Fire may also be caused by the breaking off or rupture of an exhaust pipe thus allowing the exhaust flames to enter the engine compartment.

Moreover, the deposits of fuel and oil on the engine and in the engine compartment may be ignited through damages to the electric equipment as, e.g., by a spark from a broken cable in contact with the engine, or by a spark from a poorly insulated wire in the vicinity of fuel deposits. Fire may also be started by sparks from the radio or other electric equipment (lighting system, instruments, etc.).

Fire may also be caused by frictional electricity generated by the flow of inflammable liquids through metal pipes. Exhaustive experiments in this connection were performed by Professor Dolezaleck at the Berlin-Charlottenburg Polytechnic School.\* Tensions of 100 to 1200 volts were produced with a small tank and 0.2 liter of gasoline, which was forced by compressed air through a nozzle attached to

---

\*B. Müller: "Bildung von Elektrizität in Rohrleitungen für flüssige Kraftstoffe." Auto-Technik, Vol. 14 (1925), p. 20.

the tank. Especially strong electric tensions are produced by the rupture of tanks or pipes when a jet of escaping fuel strikes the wall of a tank and is partially atomized. After a brief strong friction, fuel separates from the jet and strikes against another part of the tank wall where the voltage is equalized by a spark. Frictional electricity may also be produced by the flowing of gases through pipes, e.g. in the muffler. It is not probable, however, that such sparks can ignite a mixture of fuel and air or even liquid fuel. This must be determined by experimentation. Since frictional electricity is always generated in the tearing of materials, the rupture of tanks and pipes may produce sparks, aside from the possibility of spark production by the flowing fuel.

Fuel and oil deposits on hot engine parts (e.g. preliminary-heating devices, cylinder parts, and especially exhaust pipes close to the engine) may ignite. Explosive mixtures of fuel and air ignite still more readily. The danger is much greater in stunt and inverted flying because the normally low fuel pipes are then above so that escaping fuel is more liable to come in contact with the exhaust pipes.

A few preliminary tests were made in order to determine the temperatures at which the fuel can be ignited by the hot metal parts. (Table I.)

TABLE I

## Ignition Temperatures of Fuels on Hot Metal

Test No.	Fuels						Oils	
	Ether	Gasoline	Fuel oil 19/30	Tar oil 97/29	Alcohol	Benzol	Compressol	Voltol
	$\gamma =$ 0.714	$\gamma =$ 0.730	$\gamma =$ 0.895	$\gamma =$ 0.881	$\gamma =$ 0.813	$\gamma =$ 0.860	$\gamma =$ 0.960	F $\gamma =$ 0.933
°C	°C	°C	°C	°C	°C	°C	°C	
1	400	570	610	620	650	700	540	610
2	410	560	600	600	625	690	510	550

The experimental apparatus consisted of a flat copper pan 4 mm (0.16 in.) thick and about 140 mm (5.5 in.) in diameter, a calibrated iron-constantan thermocouple being

applied in the middle for taking the temperature. The pan was heated by means of a fine-pointed gas flame. About 1 cm<sup>3</sup> (0.061 cu.in.) of fuel was put in the pan for each test. For most of the tests the pan was heated dull red; for benzol, bright red. These temperatures occur in the inner engine parts, such as valve heads. On the outer parts (exhaust pipes, cylinder heads, heating devices, etc.,) such temperatures seldom occur.

Nevertheless, special conditions may occur which will cause a fire hazard. E.g., when an airplane crashes, fuel or oil may flow directly into an exhaust pipe and the resulting mixture with the air may be ignited by a hot valve or a glowing particle of rust.\*

Exhaustive tests on the temperatures of engine parts, both on the test stand and in flight, and on the possibilities of ignition of the most common fuels and oils on hot engine parts will be made in the near future at the D.V.L. (German Experimental Institute for Aeronautics). A few such tests have already been made. (Table II.)

TABLE II

Temperatures of the Exhaust Pipes of a  
B.M.W. Va Engine on the Test Stand

Date	Time P.M.	Temperatures						r.p.m.
		Exhaust gases			Outside wall			
		1 °C	2 °C	3 °C	1 °C	2 °C	3 °C	
9/16/30	1:38	775	740	760	240	330	270	1640
9/16/30	2:00	770	730	730	240	270	280	1612
9/16/30	2:30	775	735	740	235	370	285	1607
9/16/30	3:00	770	730	740	232	360	280	1614
Temperature of surrounding air 19°C (66.2°F.).								

\*C. F. Taylor and E. S. Taylor: "Crash Fire Tests with Diesel Oil." Aviation, N.Y., Vol. 29 (1930), No. 5, p. 283.

In a further stand test with an Sh 14 air-cooled engine a mean outside temperature of about 150°C (302°F.) was found on the exhaust pipes. The engine ran without exhaust manifold. The velocity of the cooling air was about 130 km (81 miles) per hour. The temperature measurements will be continued with several engine types, both on the stand and in flight.

In connection with this test, it was purposed to determine whether the exhaust pipes would ignite fuel or oil. The tests were made on a D.V.L. fire-extinguisher test stand with a running Mercedes D 3 a engine. Above all it was desired to determine in what form the fuel or oil strikes the hot engine part when it bursts into flame, whether in drops or jets or in larger quantities. The temperatures on the exhaust pipes were about 350°C (662°F.). The fuel or oil could not be made to ignite in any of the tests by bringing it into contact with the exhaust pipes. Even after the gasoline pipes had been brought close to the exhaust pipes, so that the fuel was brought into contact with still hotter parts, no ignition occurred. Since no general conclusion can be drawn from this test, a continuation of the tests is desirable.

The fire hazard from lightning is certainly greater than has hitherto been assumed. In the 1930 D.V.L. yearbook, in the report "Von den Gefahren des Luftmeeres," H. Koppe cites several cases in which fire was started on an aircraft by lightning. During the war lightning often set fire to airships and captive balloons. The latter were even set on fire in hot weather by atmospheric electricity before a storm.

Moreover, carelessness like the dropping of a cigarette stub may start a fire in the cabin which may spread to the pilot room and the fuel compartments. Easily inflammable articles carried by the passengers constitute a fire hazard. Smoking should be absolutely prohibited on airships using hydrogen as the lifting gas and on wooden airplanes. On metal airplanes smoking should be allowed only in specially shielded compartments.

#### On the Ground

Ground fires include those started on the ground after a crash or hard landing. Of course a landing may be necessitated by a fire which has already started in the air and which may spread further after landing. Ground fires are



far more dangerous than fires in the air because the danger of fuel tanks exploding is greater and because there is hardly any chance of extinguishing them.

In the forced landing of an airplane on unsuitable ground, various parts of the airplane, such as the landing gear, wings or the engine bearer are damaged by the sudden impact. Pipes may be broken, tanks torn loose and hot engine parts, like the exhaust manifold, be broken off. The fuel may then pour over the latter and set the whole airplane on fire within a few seconds. In the accident shown in Figure 3, no fire resulted though it is obvious that fuel from the tank x-x might easily have come in contact with hot engine parts. Fire may also be started by a spark from the breaking of a structural part. In ground fires the whole airplane is generally destroyed and lives are often lost. Ground fires may also result from other causes, e.g. when an aircraft in landing comes in contact with high-voltage conductors. A ground fire may be started by a back fire due to a sudden reduction in the speed of the engine, or to its stopping altogether when the airplane strikes the ground. Even the exhaust flames may start a fire when there is fuel in their vicinity.

Ground fires are even more dangerous on hydrogen-filled airships than on airplanes. If an airship is forced to land in stormy weather, it is liable to be driven against the ground by a sudden gust. The engine nacelles may then be demolished, the fuel tanks loosened, the piping broken and fire started as on an airplane. The airship can thus be quickly destroyed. Such was the case of the British airship R 101 destroyed in France in 1930. The danger is still greater in the case of a hydrogen-filled airship with power gas for the engines, in that some ruptured part of the structure may penetrate a lifting-gas or power-gas container and allow the escaping gas to take fire.

In 1925 crash tests were made in America in order to determine the causes of fire and its spread in the impact of an airplane against the ground. Wingless airplanes were run down a slope having a gradient of 25% (1:4). At the bottom of the slope a level stretch of about 20 m (66 ft.) led to a concrete wall against which the airplane crashed. On each side of the concrete wall there were thick protecting walls behind which a motion-picture camera was operated. As the airplane was started off the tail was lifted by a special device so that the engine was flooded with fuel. In 14 crashes there were 5 fires caused by fuel coming in contact with the hot exhaust pipes. The exhaust manifolds

were then modified and the tests repeated. We have no information regarding the changes in the exhaust pipes nor regarding the further tests. Neither is the temperature of the exhaust pipes known.

### Fires during Adjustment of Aircraft in Hangar

Even when an airplane is being inspected and adjusted in the hangar the fire hazard is very great. In overhauling an airplane all fuel and oil pipes are inspected. In loosening the connections fuel escapes into the engine compartment. Since, however, the airplane is not to be flown immediately the mechanic is not so careful to avoid the scattering of fuel. It can then be found not only in many places under the engine hood, but even on the floor and walls of the cockpit. In working on the ignition system a spark may be generated which is liable to start a fire.

In getting the airplane ready in the space in front of the hangar fire may ensue from a back fire in starting the engine due to the excessive richness of the fuel mixture and the resultant slow combustion in the intake pipe through which it gets into the carburetor. Due to the customary previous flooding of the carburetor the back fire finds abundant food. Excessive richness of the fuel in starting the engine may be due to the previous flooding of the carburetor and the injection of fuel into the cylinders in order to facilitate starting.

### III. FIRE PREVENTION

In order to reduce the above-mentioned fire hazards to a minimum it is necessary for aircraft constructors and keepers and especially designers to give sufficient attention to the subordinate structural parts. The fire hazards must also receive consideration, however, in the design of the engine and carburetor in order to secure the best results.

#### Design of Carburetor and Engine

The most commonly used float carburetor has the disadvantage that the fuel in the float chamber furnishes abundant food for the back fire, especially when there is lack of tightness. This disadvantage can be partially remedied by using the floatless type of carburetor in which there is

no large fuel supply, although it is possible, as in a float carburetor, for fuel to leak and take fire. The floatless carburetor can not entirely eliminate the danger of carburetor fires, however, because back fires can still occur. Only the direct injection of the fuel into the cylinder by means of an injection pump, as in Diesel engines, can eliminate this hazard. The Diesel method has already been successfully applied in other countries and is now being investigated in several German factories. On account of the general interest in the subject, the D.V.L. is about to experiment with gasoline injection. The greatest reduction in engine fires and the maximum degree of safety can obviously be attained only by the Diesel method with the use of heavy fuel oils.

#### Fuel and Oil Pipes

The fuel and oil pipes should be double, at least between the fire wall and engine or pump. Figure 4 shows a double fuel pipe: 1) fire wall; 2) copper wires; 3) carburetor; 4) spiral wire; 5) outside drain pipe. Figure 5 shows the details of such a pipe: a) inner pipe; b) outer pipe; c) control cock; d) connecting flange; e) nut for inner pipe; f) nut for outer pipe; g) packing ring. In order to keep the two pipes from rubbing together the inner pipe is wound with a spiral wire of light metal or with some elastic material not affected by the fuel. The outer pipe has a small drain pipe extending outside and provided with a cock. If the inner pipe breaks the fuel does not flow into the engine compartment, but continues to flow through the outer pipe to the pump or carburetor. Before every take-off and after every landing the tightness of the inner pipe can be verified by opening the above-mentioned cock. Similar models were exhibited by the D.V.L. at the 1928 Berlin International Aeronautic Exposition. As shown in Figure 6, double pipes have already demonstrated their efficacy not only in practical operation but also in accidents.

A possibility for the extensive avoidance of pipe breaks in general consists in the use of flexible elastic tubing for the fuel and oil pipes between the engine and fire wall. Such pipes have already been successfully used. One was tested by the D.V.L. in January, 1928. After a 25-hour test during which the pipe was filled with fuel under 40 atm. pressure, the material showed no signs of deterioration. Figure 7 represents a longitudinal section of such a pipe. A spiral of tinned copper wire is covered with several layers of thin leather, over which are wound several layers of impregnated linen fabric. The whole is then surrounded by a spiral wire.

Not all kinds of flexible pipes are suitable for lubricating oils, since some of them disintegrate soon under the action of the hot oil. Some kinds are surrounded with asbestos for better protection against fire. Flexible metal pipes (seamless) should not be used for the present because those hitherto used are easily broken by the continuous vibrations. It is also desirable for flexible fuel and oil pipes to be double so that, in the event of a fire, they will not burn through so quickly and liberate fuel for the further spread of the flames.

All pipes and control rods and cables should pass through the fire wall in such a way as not only to facilitate their installation and removal but also to reduce the fire hazards as much as possible. There should be no spaces through which the flames could reach the pilot's cockpit and thus interfere with the further control of the aircraft. Figures 8 to 12 suggest ways for passing pipes, rods and cables through the fire wall.

#### Fuel Pumps

In most cases the fuel pumps are mounted on the engine under the hood. Such pumps generally consist of a number of parts and have several pipe connections. There is danger that these connections may not be tight, and that considerable quantities of fuel may collect in their vicinity. So far as possible a fuel pump should be completely encased and the casing should have a drainpipe leading outside the aircraft. If complete enclosure of the pump is not always practicable, at least the places where the fuel is forced out should be provided with drainpipes extending outside.

Nowadays pumps with built-in membranes or diaphragms are often used. Such pumps are provided with slots in the part where the diaphragm is applied so that, in the event of its being ruptured, the collected fuel may drain off and not affect the working of the pump. If the diaphragm breaks while the engine is running the fuel then flows through the slots into the space around the engine. Under certain circumstances the fuel may even be forced through the slots under a slight pressure. Hence the outflow connections of such pumps should be provided with drainpipes, since the diaphragms often break.

Obviously the best way would be to install the fuel pumps outside the engine space and provide them with remote driving gear. This might consist of a shaft with universal

joint, or the pump could be operated by a small electric motor. The electric pump can be installed in any desired location, even in the fuel tank. The electric generator is best installed near the engine. There is urgent need of some such system. There are already several improved fuel pumps including the Junkers and the Avionette.

### Fire Cock

The purpose of the fire cock is to stop all fuel flow to the engine on the outbreak of a fire. Its location depends somewhat on the location of the fuel tanks. An accurate diagram of the fuel system must be included in the specifications and be put in a conspicuous place on every aircraft with special indication of the fire cock, perhaps in red. The desirability of simultaneously switching off the fuel pump and ignition and turning on the fire extinguisher by the action of the fire cock can not be decided offhand. Tests would first have to be made in order to determine the best form of the different components of such a system, especially with regard to the matter of weight. It should be possible to operate the different components separately, as well as simultaneously. Fire during flight does not always necessitate landing. The pilot, after closing the fire cock, should still be able to control all the other devices.

### Pipe Connections

In order to avoid pipe breaks and thus reduce the fire hazards, no solder should be used. Hard soldering makes the pipes very brittle so that they break easily. All fuel and oil pipes should therefore have solderless joints. Many very practical pipe connections are now available, some of which have been tested by the D.V.L. The nuts must be adjustable and capable of being securely locked. On long pipes the intermediate connections must be flexible, or at least so installed as to permit yielding. A comprehensive series of solderless pipe connections can be found in "Fakra" No. 21, November 1, 1928 (bulletin of the Standardization Committee of the Motor-Vehicle Industry).

### Fuel and Oil Tanks

The fuel and oil tanks must be installed as far as possible from the engine, so that they will not be immediately

reached by a fire breaking out under the engine hood. The compartment containing the tanks must be well ventilated. It would also be possible to fill the tank rooms with an incombustible gas and seal them up tightly. Perhaps the exhaust gases could be used for this purpose.

In order to have as little fuel as possible on board in the event of a forced landing, which is liable to result in a crash, the tank may be installed in such fashion that it can be released by means of a hand lever. (Fig. 13.) Since it may not be possible to install this device on every airplane, the fuel tanks may be provided with quick-emptying devices with outlets at the bottom of the fuselage. The outlet pipe must be as large as possible in order to empty the tanks quickly in the event of a fire during flight or of a forced landing.

The extent of the rupture of a tank and the scattering of the fuel in a crash can be reduced by putting inside the tank a hollow body whose size bears a certain ratio to that of the tank. The deformation of this body will absorb a large share of the energy freed by the impact of the tank. The pressure resistivity of the hollow body is adapted to that of the tank. Such tanks were tested by the D.V.L. in July, 1929. Although enough such tests have not yet been made, it has been demonstrated that fuel tanks containing hollow bodies can withstand greater impact stresses than ordinary tanks. This is clearly shown by Figures 14 and 15. Further tests of this kind should be made.

Fuel tanks have been covered with a special rubber-like or gunny skin. In the event of the wall of the tank being punctured by a structural member or by a bullet, this skin would immediately close the hole and prevent the escape of the fuel. Several tests were made in America with this sort of tank. These tests are said to have been successful, though no results were published.

Tests were made in England with a device which, in the event of a crash, automatically shuts off the fuel and may be used for the simultaneous operation of a fire extinguisher or the breaking of the electric circuit. The device consists of a glass vacuum bulb which, when the airplane crashes, is broken against a sharp edge installed for this purpose. The negative pressure produced by the breaking of the bulb operates the safety devices.

### Exhaust Pipes

The fire hazards are greatly affected by the form and arrangement of the exhaust manifold and pipes. The manifold connections which are attached to the cylinders must lie outside the engine housing and be exposed to the wind. Where this arrangement is not practicable the portions of the manifold connections inside the engine housing must be shut off from the rest of the engine space so that fuel deposits can not come in contact with the hot parts which may reach, during operation, a temperature of 350 to 500°C (662 to 932°F.) or even higher.

The construction of the exhaust manifold from light metal with cooling fins may keep the temperature of the outer wall below 250°C (482°F.), if this type can be made sufficiently safe. Tests were made at the D.V.L. with an exhaust manifold from a German factory but the results do not yet warrant any final conclusion. (Fig. 16.) Further experimentation in this direction is desirable and will be undertaken in the near future.

In order to prevent the escaping fuel, in the event of a crash, from being ignited by the hot manifold, it might be possible to install a device for spraying the manifold with a liquid which would cool the manifold enough in a few seconds so the fuel could not ignite.

### Preheating Devices

In water-cooled engines the preheating of the intake air has no particularly unfavorable effect on the fire hazards because it is accomplished either by drawing the air through the engine housing or by the return flow of the oil or heated cooling water. On air-cooled engines, preheating of the intake air by the exhaust gases is allowed in Germany only when the exhaust and hot-air conduits are situated outside the engine housing.

When, due to special structural conditions, a preheating device must be installed under the engine hood, the preheating pipes must be shielded from the fuel and oil pipes or run through other pipes so that leaking fuel can not come in contact with them. The question of preheating will be considered more in detail in a later report.

### Magnetos, Spark Plugs, Ignition Cables

These must be well insulated. All fuel and oil pipes should be located, in so far as possible, below the ignition system so that the latter will not be sprayed with leaking fuel or oil. The connections must not be affected by vibrations. Electric cables must be enclosed in an insulating tube so that if one of them becomes disconnected it can not come in contact with the engine or engine housing.

On aircraft provided with a radio plant, the insulated cables are enclosed in a metal tube for better protection. The danger from sparks is thus greatly reduced, since the metal covering is connected with the main mass of metal. This method of shielding has been largely adopted in other countries.

Since the complete encasing of the distributor does not appear advisable under certain conditions, due to the formation of ozone by the sparks, and since the life of the spark plug is already shortened by acid deposits and corrosion of the metal for lack of sufficient ventilation, the space around the distributor should be ventilated by the introduction of fresh air from outside the airplane. This method, however, may not always be practicable. The placing of a wire screen over an orifice of the distributor should generally suffice. The ventilation is not affected by the screen. No case has yet been known where fire was started by sparks from the distributor.

### Electric Plant

A prerequisite condition for the further reduction in the number of aircraft fires is the suitable installation of the electric wires. When installing a system of electric wires, great care should be taken to avoid the possibility of short-circuiting. It is one of the most important duties of inspectors and mechanics to see that the electric wires are correctly installed and always in perfect condition.

In order to avoid danger of igniting the fuel mixture by sparks from the electric equipment, special attention must be given to the shielding of the switches and commutator. Suitable forms for the elements under consideration are included in the German specifications for airplane construction and are strictly required by the air traffic companies.



In crashes there is always danger of sparks from the breaking of copper cables and contact of the copper core with other electric conductors. It has been found that this can be prevented by covering the cable with a wax coating which, in the event of a break, is elongated by the tension and covers the broken wire ends. All electric wires should therefore be covered with wax. The danger of short-circuiting can be further diminished by the general use of bipolar wiring.

Another safety device adopted by the German Luft-Hansa Company on all its airplanes is a short-circuit push button which melts a safety fuse and shuts off the current from the whole system.

The location of the generators and storage batteries is also important. These should be installed as far aft as possible because the rear part of the fuselage is generally the least damaged in a crash. A further advantage of this arrangement is the long distance between the generator and the fuel tank. This manner of installation can generally be adopted, however, only on large airplanes with special power plant or fan drive of the generator. There is an increasing tendency to operate the generator by the engine. This makes it necessary to install the generator near the engine, thus necessitating special consideration of the fire hazards.

The radio plant must be installed with special care. The German Luft-Hansa has already adopted numerous safety devices which have proved very satisfactory. One is an insulated fireproof case for the radio instruments, including a switch for cutting off the radio generator.

### Fire Wall

The fire wall, separating the engine from the pilot and passenger cabins, must be flame-tight and flameproof and made of material capable of withstanding the flames for a long time. It now generally consists of an asbestos sheet enclosed between two duralumin sheets about 0.5 mm (0.02 in.) thick, in part of sheet duralumin alone. Experience has shown that such a fire wall is not effective in all cases. In one airplane fire the duralumin portion of the fire wall was completely consumed while parts made of sheet steel remained intact.

In most cases the fire wall consists of several pieces of sheet metal which abut one another and are riveted to-

gether by means of overlapping strips of metal with intervening strips of asbestos. Fuel gets between the metal parts of the joint and saturates the asbestos. In case of fire under the engine hood this point is quickly attacked and the fuel-saturated asbestos is liable to be explosively torn cut. The fire then reaches the parts of the airplane behind the fire wall. Even before the fire the asbestos strips may have been destroyed by the vibrations.

When the fire wall consists of several metal sheets they must overlap. The best material is sheet steel with asbestos lining. The D.V.L. is now conducting experiments in this connection. Sheet elektron should never be used. In the section on "Fuel and Oil Pipes" reference has already been made to the necessity of the flame-tight passage of all pipes through the fire wall.

#### Material for the Engine Cowling

Sheet elektron or aluminum are often used for the engine cowling. It is well known that sheet elektron burns readily under certain conditions. It should not be used for engine cowlings. Fire-extinguishing tests with burning sheet elektron have shown that burning portions are thrown off with explosive violence when sprayed with carbon tetrachloride. In a test with a dry extinguisher it was likewise impossible to smother the burning parts.

Figures 17 to 19 show tests with elektron engine cowlings. In these tests the time required for the ignition of sheets of different thicknesses was found to vary. A sheet 0.8 mm (0.03 in.) thick ignited quicker than a sheet 1 mm (0.04 in.) thick. The thicker sheet burned more intensely however. No definite conclusion can yet be drawn from these tests. Further tests will be undertaken at the D.V.L. in the near future.

#### Protection against Back-Firing

In order to diminish the fire hazards from back-firing wire screens may be inserted in the intake pipes to prevent the flames from reaching the carburetor. There are various forms of protective devices against back-firing. It is yet to be determined whether these devices cause much loss in engine power. Tests would also have to be made in order to determine whether back fires can be prevented from reaching the carburetor by structural changes.

### Safety Measures for Refueling in the Air

In the transfer of fuel and oil in the air from one airplane to another, the most elaborate fire-prevention measures have been developed. In a system developed by the D.V.L. the refueling hose, when subjected to excessive tension, automatically separates from its connection with the lower airplane. Simultaneously a valve at the lower end of the hose automatically closes so that no fuel can escape. It can be determined only by further experimentation as to how much the fire hazards from refueling in the air can be further reduced.

## IV. FIRE FIGHTING

### General Statements Regarding Fire Extinguishers

In order to fight a fire successfully, whether the burning aircraft is in the air or on the ground, it must carry apparatus specifically designed for this purpose. There are various extinguishers for fighting incipient and advanced fires. Some of the hand extinguishers have been adopted for general industrial purposes. Only a few are suitable for use on aircraft. Several have been tested by the D.V.L. There is still need of further improvement.

### Fire-Extinguishing and Pressure-Producing

#### Substances for Fire Extinguishers

The only available fire-extinguishing substances for aircraft are carbon tetrachloride and carbon dioxide. The latter is better for injection into the carburetor and air intakes but not for fires under the engine hood. Carbon dioxide is not much used, carbon tetrachloride being more suitable. The strong extinguishing effect of this substance is well known.

Dry extinguishing substances (powders) should not be used since in extinguishing a fire particles of the powder may get into the carburetor and other open parts of the engine (valve springs and valve-stem guides). They may also get into the cylinder and cause the piston to seize, thus entailing an accident. Moreover, since the powder must be forced through pipes to the various outlets, a pipe may easily become stopped and thus render the extinguisher useless.

The fire-extinguishing substance must not injure the structural materials of the aircraft.

The vapors produced by spraying carbon tetrachloride on a fire are harmless to persons notwithstanding the presence of a little phosgene. The inhaling of large quantities of such gases causes a cough-exciting irritation, but without harmful results.

The "Chemisch-Technische Reichsanstalt" experimented with carbon tetrachloride and, after completion of the tests, announced the following results: "In extinguishing oil and benzol fires, as likewise oil-soaked cotton waste, in the absence of catalyzers, low phosgene values were found, reaching a maximum of hardly twenty milligrams per cubic meter."

It should be noted that these experiments were performed in closed poorly-ventilated rooms, while in using carbon tetrachloride to extinguish fires on aircraft the generated vapors are carried quickly away by the wind and the air currents under the hood.

The extinguishing substance must be effective at  $-45^{\circ}\text{C}$  ( $-49^{\circ}\text{F}$ ). Hence it is necessary to add something to the carbon tetrachloride, which crystalizes at about  $-22^{\circ}\text{C}$  ( $-7.6^{\circ}\text{F}$ ), in order to lower its freezing point to  $-45^{\circ}\text{C}$ .

The most suitable pressure-producing substances are compressed air and compressed nitrogen. An extinguisher which employs compressed air and maintains a continuous pressure can be provided with an indicator so that it can be constantly regulated. It can also be readily refilled.

An extinguisher whose operating pressure is produced at the time by the introduction of a pressure cartridge can not be regulated. The pressure cartridges must therefore be very carefully tested (shaking device, etc.) to determine whether the operating pressure will last long enough.

A continuous-pressure extinguisher may develop leaks in the connections and joints after a long time, while an extinguisher in which the pressure is produced only at the moment of using is not so liable to develop leaks. No definite pressure-producing means can yet be prescribed for all extinguishers, particularly automatic ones.

### Hand Extinguishers

There must always be one or more hand extinguishers on an aircraft, according to the size of the passenger cabin, baggage room, engine nacelle and pilot cockpit. A hand extinguisher must be conveniently located and easily removable from its support. It must also be possible to extinguish several successive fires with one and the same extinguisher. The meeting of this requirement depends more or less on the design of the extinguisher. On each extinguisher there should be printed instructions for its operation so that even a passenger may be able to use it. Each type must be specially approved and be tested beforehand in regard to its suitability for use on aircraft. All fire extinguishers should be inspected at least once in three months. Other conditions are described in "Specifications for Airplanes." At least one liter (about a quart) of the fire-extinguishing liquid should be provided in view of the fact that the cabin extinguisher must also be available for engine fires.

Figure 20 represents a cabin fire extinguisher (the "Minimax Ka" hand extinguisher) tested by the D.V.L. The extinguisher is removed from its holder and the pin a driven in by striking it against something. This opens the pressure cartridge b and the compressed air (or nitrogen) forces the liquid through the tubes c and d into the pipe e. By turning the hand wheel f the liquid is released through the nozzle g.

### Automatic Fire Extinguishers and Alarms

In Section II ("Causes of Fire"), it was stated that fires are especially liable to occur in the engine space where, due to the engine cowling and the fire wall, it can not be immediately observed by the pilot. The latter is not generally aware of such a fire until smoke or flames issue from the engine housing and not till then does he use the fire extinguisher. The fire may then be too big to be extinguished by the limited amount of extinguishing liquid that can be carried.

It is therefore important to install some device to warn the pilot of the fire before it is too late. Fire alarms have already been used successfully in other countries. Figure 21 shows a fire alarm for automobiles which can also be used with slight modifications on aircraft. When the celluloid strip a is burned through, the spring b presses the knob c against the pole shoe d, thus

closing the circuit through the cable e and operating an optic or acoustic signal near the pilot.

The best device of all appears to be a fire extinguisher which operates automatically on the outbreak of a fire and which can also be set in operation by the pilot. Figures 22 to 24 show several German automatic fire extinguishers which have been tested by the D.V.L. and pronounced suitable for use on aircraft.

Figure 22 shows the automatic extinguisher "Minimax Hap 1." As soon as an ignition cartridge, installed inside the engine cowling and connected with the pressure pipe a, is released by the fire the pressure is transmitted through the pipe a to the cylinder b, forcing the extinguishing liquid through the valve c into the pipe d and through the nozzles situated in the engine space. The cylinder b is provided with a manometer e and a filling plug f. The extinguisher is also provided with an electric hand release.

Figure 23 shows the automatic fire extinguisher "Phylax-Aero-Typ." The cartridge a is discharged by an ignition cap mounted inside the engine cowling. The striker located in the neck b of the cylinder c is pushed into the cylinder and causes the reaction of the chemicals in the pressure cartridge. The pressure thus developed forces the liquid in the cylinder through the pipe d to the nozzles in the engine space. The extinguisher is also provided with a hand release (mechanical or electrical).

Figure 24 shows the "Trutmania M" carburetor fire extinguisher. The liquid fills the cylinder a, as likewise the pipes b as far as the automatic releases c under continuous pressure. As soon as the fuse d is melted by the fire, the bridge e is pushed from the orifice f by the liquid pressure and the liquid escapes. The liquid may also be made to flow to the engine through a hand-operated valve g at the top of the cylinder. The extinguisher is provided with a manometer and a filling plug.

The installation of automatic fire extinguishers should be stipulated in aircraft specifications. They should be installed on aircraft and inspected at intervals of 4 to 5 months. These measures are necessary in order to obtain effective extinguishers and correspondingly greater safety for aviation.

### Installation of Extinguisher for Engine Fires on a Single-Engine Airplane

The cylinder containing the fire-extinguishing liquid should be installed, if possible, in the cockpit so that it can be operated either by the pilot or mechanic and so that it may be easily cared for or replaced. It should bear a conspicuous label containing the following information: type, liquid, quantity of liquid, maximum and minimum operating pressure, manufacturer, factory number, inspection mark, test period, date of last inspection.

The pipes must conform to the specifications for fuel and oil pipes. The number of spray nozzles depends on the size and type of the engine, as well as on the kind of nozzle. In general all the air intakes, the carburetor, and the engine space must be provided with nozzles. The engine space is best protected by installing a nozzle in each of the four upper corners so that the whole space will be sprayed. Nozzles should also be installed near all especially endangered points (carburetor, fuel pumps, oil pumps and lower part of engine space near fire wall).

### Arrangement of Extinguishers on Multi-Engine Airplanes

This depends on whether the extinguisher is automatic or hand-operated. If the latter, the containers for all the engines are best located in the cockpit. In the case of automatic extinguishers, each engine nacelle may be provided with a separate extinguisher. It is advisable, however, to provide each of these extinguishers with a remote control which can be operated from the cockpit. The arrangement of the pipes and nozzles is the same as on single-engine airplanes.

Figure 25 represents the installation of a two-liter automatic fire extinguisher on a water-cooled engine.

- a) Cylinder with enclosed pressure cartridge.
- b) Automatic releases (ignition caps).
- c) Ignition-pressure pipes for actuating pressure-cartridge.
- d) Pipes for fire-extinguishing liquid.
- e) Spraying nozzles.

Figure 26 represents the installation of a one-liter automatic fire extinguisher on an air-cooled engine; legend same as for Figure 25.

## Fire Extinguisher for Passenger Cabin

In the passenger cabin the hand extinguisher must be so placed as to be immediately recognizable and easily removable by a passenger. It should be large enough for an engine fire or for use outside the airplane in the hangar.

## Test Plant of D.V.L.

The D.V.L. plant for testing fire extinguishers consists of the fuselage of an old Fokker airplane equipped with a Mercedes D III a engine. The extinguisher is installed in the usual way and its effect is tested with the engine running and with an artificially produced fire. (Fig. 27.) The tests are made in the slipstream from another airplane placed in front of the test airplane so as to approximate the conditions of actual flight.

A future report will deal with the design of the whole power plant with regard to fire prevention and fire fighting and also with various fire-fighting devices.

Translation by Dwight M. Miner,  
National Advisory Committee  
for Aeronautics.



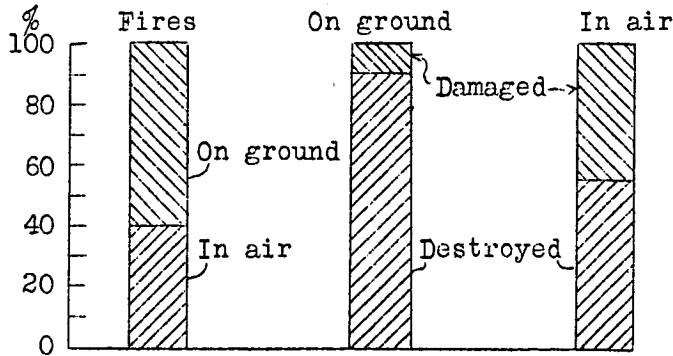

Fig.1

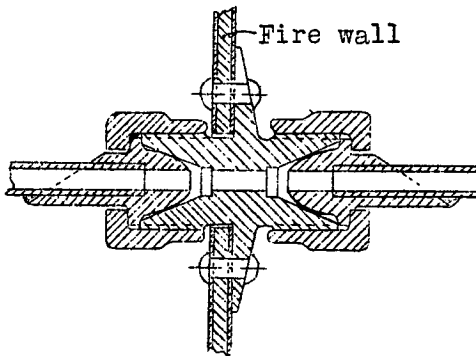

Fig.8 Flame-proof passage through fire wall.

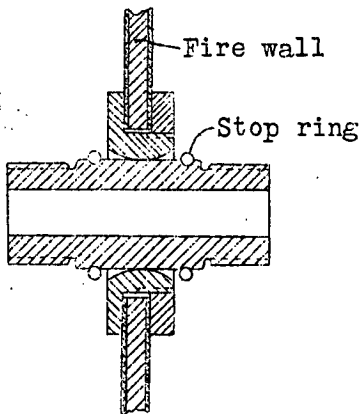

Fig.9

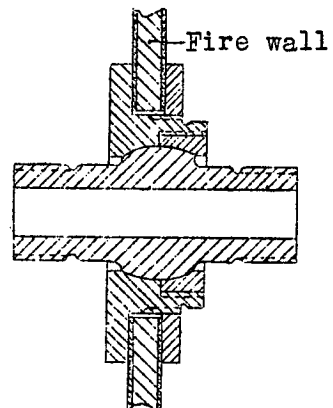

Fig.10

Figs.9,10 Movable fittings for passage of double fuel pipe through fire wall



Fig. 2

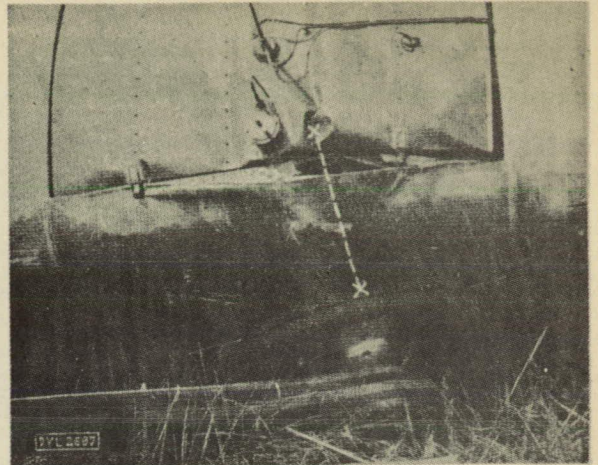

Fig. 3

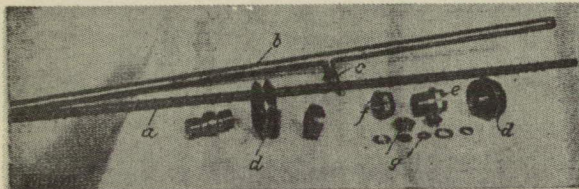

Fig. 5 Details of double fuel or oil pipe.

- a, Inner pipe      d, Connecting flange  
 b, Outer pipe    e, Nut for inner pipe  
 c, Control cock   f, Nut for outer pipe  
 g, Packing ring

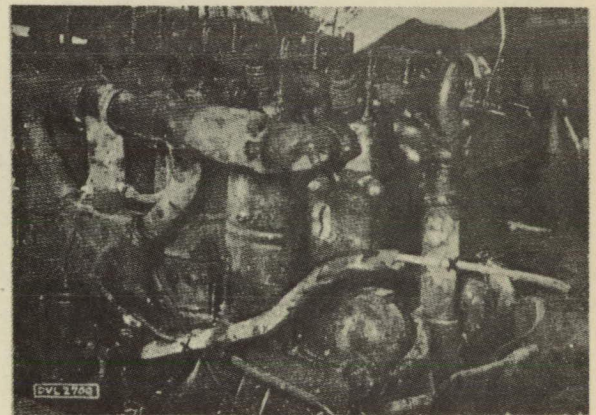

Fig. 6 Double fuel pipe after fire.  
 Inner pipe remained intact.  
 x - x, double pipe.



Fig. 15 Fuel tank after drop with inclosed hollow body.



Fig. 14 Fuel tank after drop without inclosed hollow body.



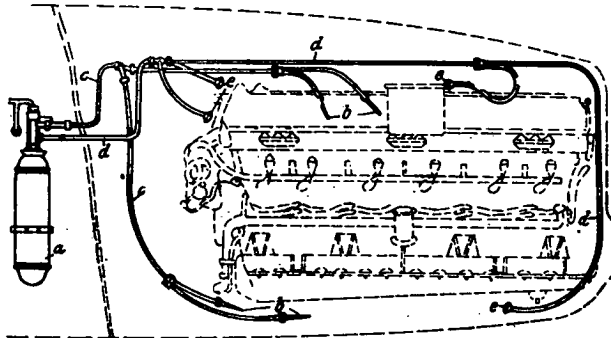

Fig. 25 Automatic extinguisher on water-cooled engine.

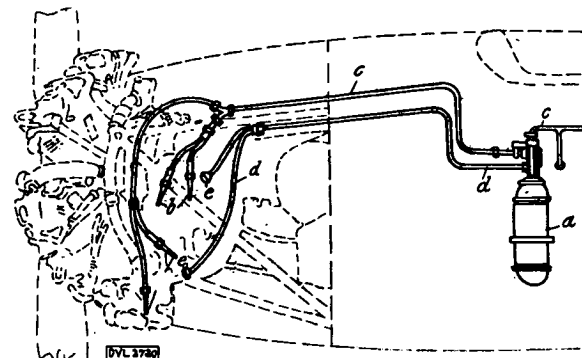

Fig. 26 Automatic extinguisher on air-cooled engine.

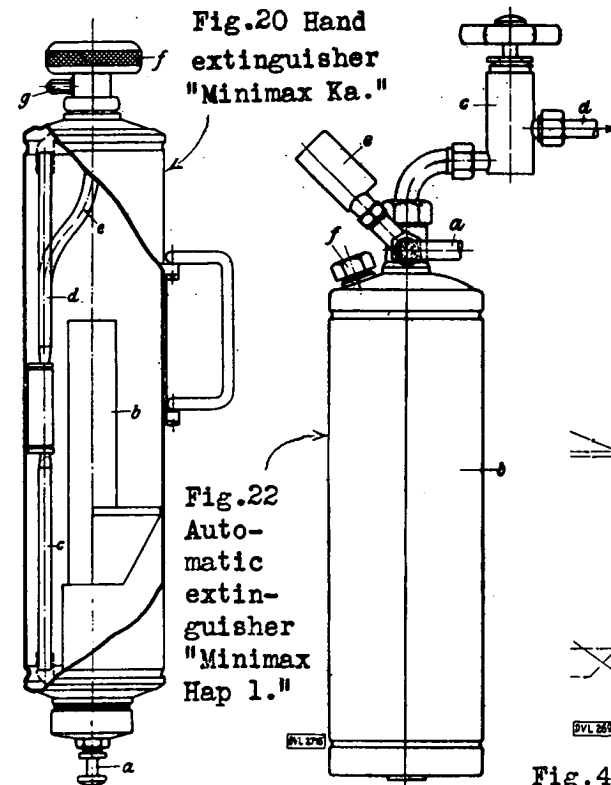

Fig. 20 Hand extinguisher "Minimax Ka."

Fig. 22 Automatic extinguisher "Minimax Hap 1."

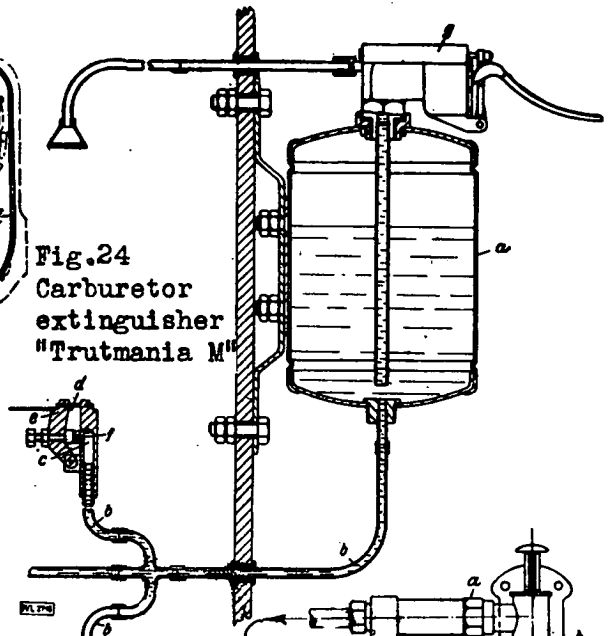

Fig. 24 Carburetor extinguisher "Trutmania M"

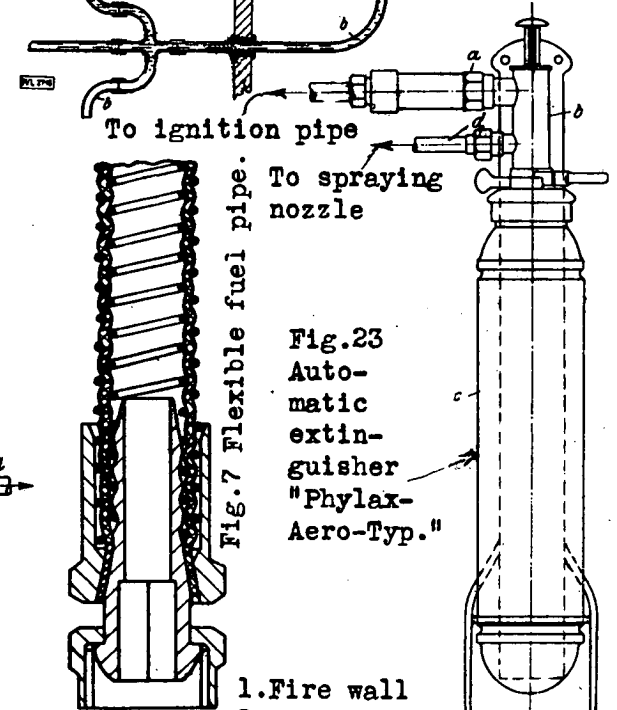

Fig. 23 Automatic extinguisher "Phylax-Aero-Typ."

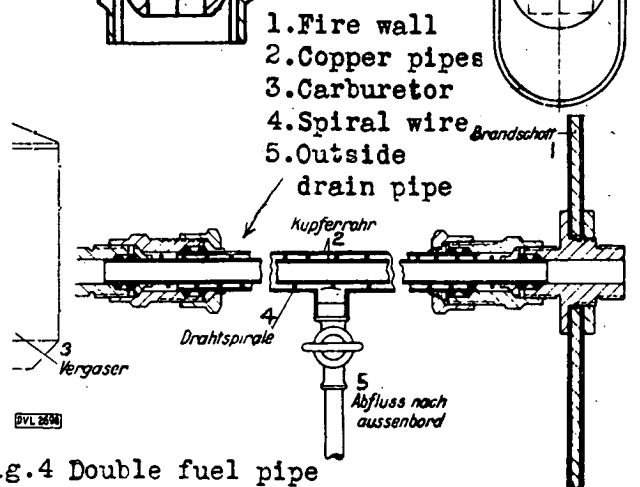

Fig. 4 Double fuel pipe

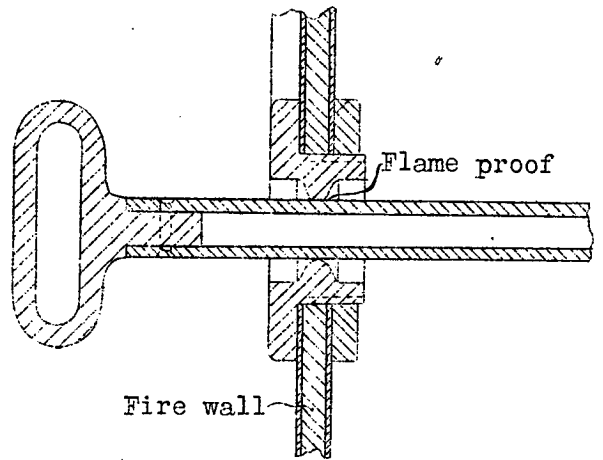
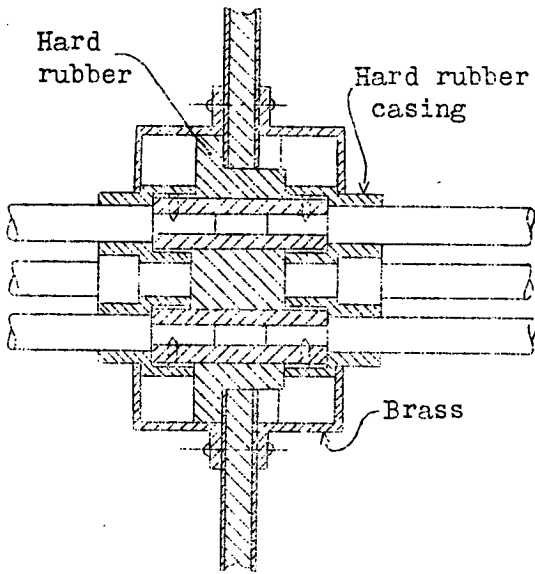

Fig.11 Cable manifold in fire wall.

Fig.12 Control rod for ignition and gas.

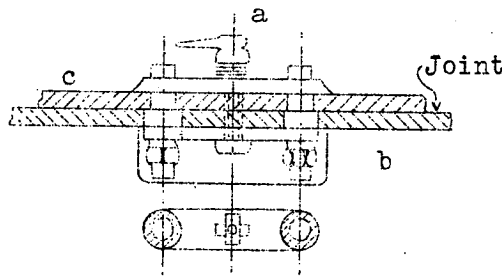

Fig.13 Device for dropping fuel tank. Turning the lever a releases tank b from part c.

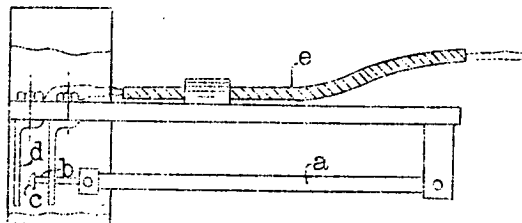

Fig.21 Automobile fire alarm.

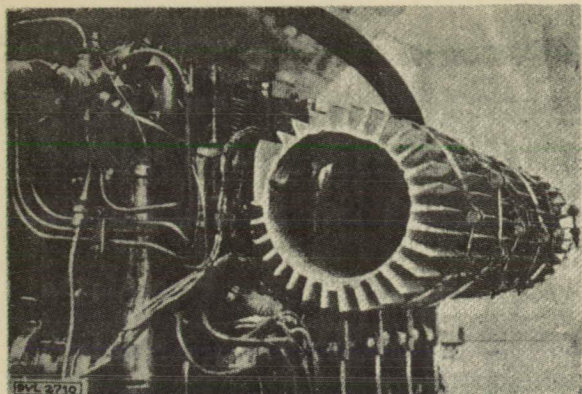

Fig.16 Air-cooled light-metal exhaust manifold with cooling fins.

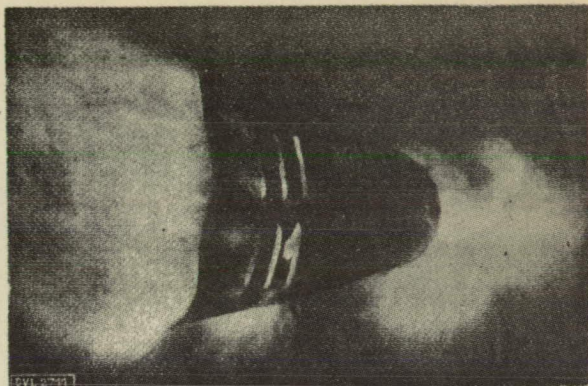

Fig.17 Model of engine cowling made of 1 mm elektron. Gasoline fire in cowling.

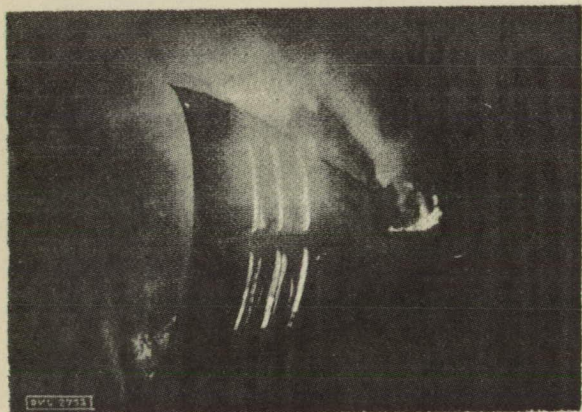

Fig.18 Model of engine cowling made of 1 mm elektron. Gasoline burning in air blast.

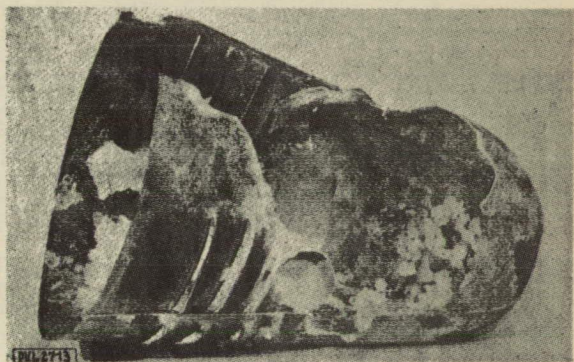
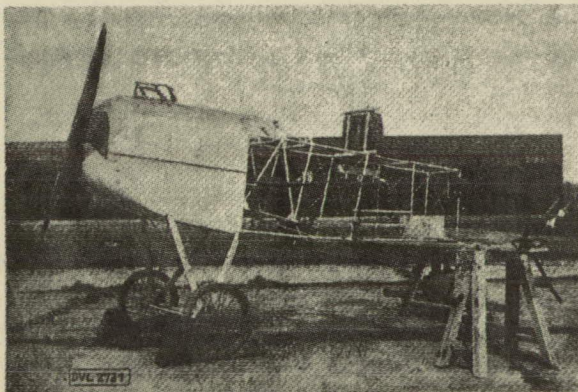

Fig.19 Remains of elektron cowling after fire.

Fuselage of an old Fokker airplane equipped with a



Mercedes DIIIa engine, used in fire extinguishing test.

Fig.27