

## TAB INTERCONNECTS FOR SPACE CONCENTRATOR SOLAR CELL ARRAYS

J. Avery, J. S. Bauman, P. Gallagher and J. W. Yerkes  
Boeing Defense and Space Group, Seattle, WA. 98124

### ABSTRACT

The Boeing Company has evaluated the use of Tape Automated Bonding (TAB) and Surface Mount Technology (SMT) for a highly reliable, low cost interconnect for concentrator solar cell arrays. TAB and SMT are currently used in the electronics industry for chip interconnects and printed circuit board assembly.

TAB tape consists of sixty-four 3-mil/1-oz tin-plated copper leads on 8-mil centers. The leads are thermocompression gang bonded to GaAs concentrator solar cell with silver contacts. This bond, known as an Inner Lead Bond (ILB), allows for pretesting and sorting capability via nondestruct wire bond pull and flash testing. Destructive wire pull tests have resulted in preferred mid-span failures. Improvements in fill factor have been attributed to decreased contact resistance on TAB bonded cells.

Preliminary thermal cycling and aging tests have shown excellent bond strength and metallurgical results. Auger scans of bond sites reveals an Ag-Cu-Tin composition. Improper bonds are identified through flash testing as a performance degradation. On going testing of cells are underway at Lewis Research Center.

SMT techniques are utilized to excise and form TAB leads post ILB. The formed leads' shape isolates thermal mismatches between the cells and the flex circuit they are mounted on. TABed cells are picked and placed with a gantry x-y-z positioning system with pattern recognition. Adhesives are selected to avoid thermal expansion mismatch and promote thermal transfer to the flex circuit. TAB outer lead bonds are parallel gap welded (PGW) to the flex circuit to finish the concentrator solar cell subassembly.

### HISTORY

Three methods are available today for chip level inter-connects. Wirebonding, soldering, and TAB. Wirebonding is the most common chip-bonding technology utilized in the defense industry. This technology requires the chip to be bonded to be first attached with adhesives to the substrate or printed wiring board. Wirebonds are then placed one at a time from chip to substrate. Several bonds per second can be made by wire bonding. Soldering, also known as "flip chip", requires solder bumps to be attached to the chip. The chip is then flipped over and bonded to its substrate. TAB allows for many leads to be bonded simultaneously to the chip. General Electric first introduced TAB in the late 1960s as a possible replacement for wire bonding technology. It wasn't until the 1980s that TAB became of interest as a natural extension of SMT. The greatest percentage of TAB used today is for liquid crystal displays, watches, cameras, memory cards, smart cards, thermal printer heads, pocket televisions and calculators, notebook computers and office equipment. TAB is also use in high reliable applications such as personnel and mainframe computers.

Boeing first purchased a thermal compression gang bonder from Jade in 1985 for evaluating TAB bonding. Boeing's High Technology Group (HTC), concentrated on developing the substrate, while the Advanced Packaging Group focused on producing the TAB memory component using an IC memory device. Their experience concluded that the semiconductor design needed thicker metalization to accommodate TAB. This meant that all components that were to be use would needed to be custom. Add to this the low volume need, cost became prohibited.

During the first quarter of 1992, the Prototype Development Group at HTC, began evaluating the use of TAB bonding on their concentrator GaAs solar cell. TAB bonding studies using a laser were conducted at MCC by Doug Pietilla, assignee from Boeing. Although successful, this process was eliminated due to the cost of the capital equipment. Thermal compression single point bonding with 1- by 3-mil ribbon was also evaluated. The success of single point thermal compression bonding, led to evaluating thermal compression gang bonding as a baseline. A Jade thermal compression gang bonder was liberated from surplus status and move to the Prototype Development Group for further evaluation.

## TAB TAPE DESIGN

Fatigue resistance and current carrying capability constitute the most important issues in the functional design requirements for the concentrator solar cell interconnect. Two distinct types of fatigue plague electrical connections in earth orbit: lead bending and joint shear. Lead bending stress is minimized by maximizing the lead length, limiting the lead thickness and providing a strain relief to eliminate pure tensile loading.

Lead length is limited by manufacturing considerations in that long leads are easily damaged during handling. This may occur between operations in ILB, lead form and excise and outer lead bonding. Unsupported beam length should not exceed ten times the width of the beam according to 3M. Lead thickness is a function of manufacturing preference since all other variables can be manipulated after a choice is made. TAB tape producers have made 1 oz (1.4 mil) copper the standard. Their tooling and processes are aligned with this choice.

Cyclic thermally induced strains in the TAB lead occur in orbit. The lead must be shaped in such a way that the preferred bending mode is across the thinnest dimension of the beam. This will minimize strains, stress and in turn improve fatigue life. The thinner the beam the smaller the strain, the lower the stress and longer life. According to the above constraints 1.4-mil thick copper was the obvious choice.

Strain relief is provided inherently when a lead traverses planes ie. from the top of the cell down to the base flex circuit. A special case exists where the TAB is bonded to the bottom of the cell and to the circuit which all occurs in one plane. For this situation a pipeline type (omega shape) strain relief must be formed in the TAB lead.

Handling joint fatigue is less a matter of TAB design than the metallurgy of the joint, covered later. A joint no larger in any dimension than the width of the lead is required to minimize the shear stress induced due to mismatched coefficients of thermal expansion at the bond interface.

Current carrying capability must be maximized to avoid significant loss of power in the system. The space available on the cell for bonding leads from each TAB is 0.265" less side margins. Using 3-mil wide leads on 8-mil pitch, 32 leads can be bonded comfortably on the cell. This gives a collective resistance of  $4.5 \times 10^{-4}$  ohms per buss. Previously, gold wires were used which had a total resistance of  $3.4 \times 10^{-4}$  ohms per buss.

## ILB METALLURGY

Boeing concentrator solar cells utilized gold contacts for inner lead bonding. This was ok for R&D quantities, however cost prohibitive for production. Boeing contracted Spectrolab to make 200 each Boeing GaAs concentrator solar cells with silver contacts. In the mean time sample Spectrolab one sun cells with silver contacts were obtained for evaluation of TAB thermal compression gang bonding. The cells had only 4 microns of silver, were GaAs on germanium, and had no dielectric layer under the contact area. In short the silver was too thin and the cell wafer was different. These one-sun cells were diced to 0.265 by 0.305 inches to begin to evaluate TAB bonds to silver. The silver contact areas to be bonded had an anti-reflective coating on them which made TAB bonding difficult. It was removed with a pencil eraser to expose the silver contact area and sample TAB bonds were made.

The metallurgy of the ILB is expected to be described by a ternary system consisting of 5 to 10 percent tin with equal remaining parts of copper and silver. A diagram representing this system can be found in ("Ternary Alloys: A comprehensive Compendium of Evaluated Constitutional Data and Phase Diagrams, Vol 2", edited by G. Petzow and G. Effenberg, Published by Verlagsgesellschaft, 1988). Considerable information should be available on this ternary as it forms the basis for dental amalgams. Intermetallic compounds (IMC) growth in this ternary system is also expected. The equation for IMC thickness versus time and temperature have been described by (D. Frear, W. Jones and K.

Kinnsman, "Solder Mechanics: A State of the Art Assessment, Chapter 2, Trans Metallurgical Society 1990"). They show that a .5um thick tin plate on the copper leads will be consumed in a relatively short period of time at 60 degrees C in the formation of Ag-Sn and Cu-Sn intermetallic compounds (even if IMC formation during bonding is not considered). The compounds expected to form are  $Ag_3Sn$ ,  $Cu_6Sn_5$ , and  $Cu_3Sn$ . This bond may not necessarily be weaker.

### ILB PROCESS DEVELOPMENT

The tool that is used to make a thermal compression bond is known as a thermode. The thermode used in this experiment was made from tungsten carbide with the Prototype Development's wire EDM machine. The bonding footprint was 0.005 x 0.300 inches. Right angled edges on the first designed thermode caused the TAB leads to be coined and partially sheared at the bond site. Bonding however proved to be encouraging with good pull strengths of greater than 40 grams per lead. The first thermode was chipped during process development. This led to a revised design eliminating sharp thermode edges with radii. The coining was reduced to an acceptable level. Lead failures during pull testing resulted at places other than the coined edge.

One-sun cells were gang bonded and flash tested. These cells degraded up to 5 percent in fill factor and voltage. Auger scans of the metallurgy revealed copper in the junction below the ILB. About 50% of the ILBs that were sampled showed a good contact. The copper in these bonds did not diffuse into the junction. The gang bonded cells were then thermal cycled 250 times from -70 to +96°C and flash tested again. Further degradation was observed and attributed to the lack of a dielectric layer to impede copper migration into the solar cell junction. Boeing cells with gold contacts were then bonded. They showed no degradation from bonding due to the dielectric layer under the contact area impeding copper migration. However the thinness of the gold contact made for a weak bond.

### ILB PROCESS

Critical bonding parameters for successful ILB include thermode planarity, thermode temperature, stage temperature, bond time, bond force, and solar cell TAB tape alignment. In September of '92, we received our Boeing/Spectrolab transparent GaAs concentrator solar cells. Several cells were bonded and pull tested. Pull testing helped correct process parameters. Thermode planarity could be identified by uniform pull strength of the 32 tabs being bonded. If the thermode was off, weak bonds of around 30 grams would be on one side while strong bonds with cratering would be on the other side of the solar cell. Once thermode planetary was adjusted the other parameters were evaluated until favorable mid span lead breakages were made while pull testing. Pull test strengths were optimized at  $45 \pm 5$  grams per lead. General process parameters that were successful were as follows:

Thermode Temperature	550 to 600°C	Bond Time	3 seconds
Stage Temperature	150°C	Bond Force	8 psi

With the ILB process established 45 each Boeing/Spectrolab cells were flash tested and bonded then flash tested again (see figures 1, 2 and 3). Two out of the 45 were eliminated from the data due to silver metal damage from prior dicing. The rest of the cells proved to be undamaged by the bonding process. Shifts in fill factor, voltage, and current averaged less than 1 percent, (see table 1).

Table 1. Boeing/Spectrolab Silver Contractor Solar Cells

	Before TAB			After TAB		
	FF	Voc	Isc	FF	Voc	Isc
Average	0.7628	1.0808	0.3648	0.7608	1.0830	0.3608
Standard Deviation	0.0397	0.0149	0.0092	0.0433	0.0168	0.0088
Range	0.16	0.057	0.0409	0.191	0.074	0.0438
Average Shift	0.27%	0.20%	1.09%			

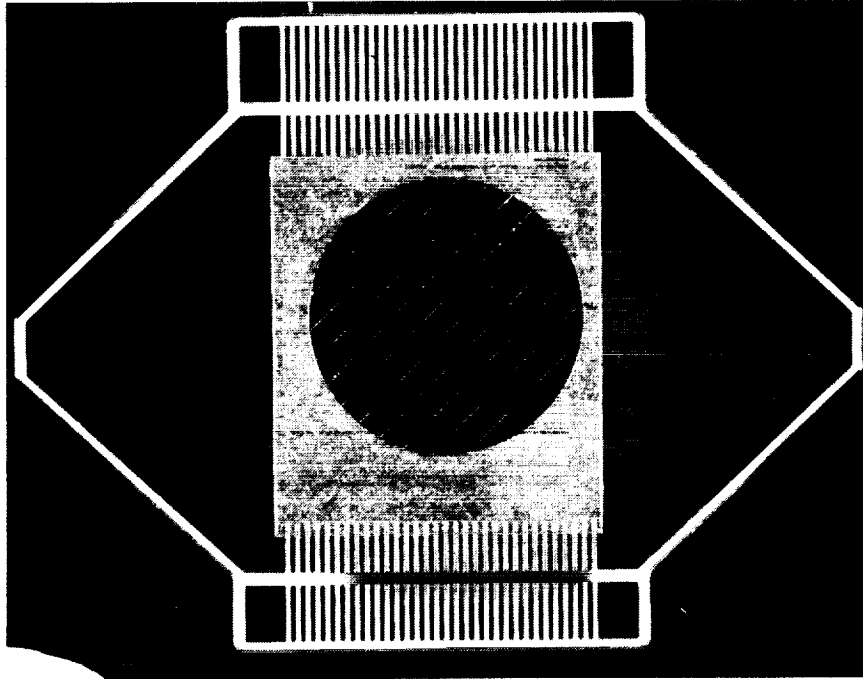

*Figure 1. TABed Boeing/Spectrolab GaAs Concentrator Solar Cell*

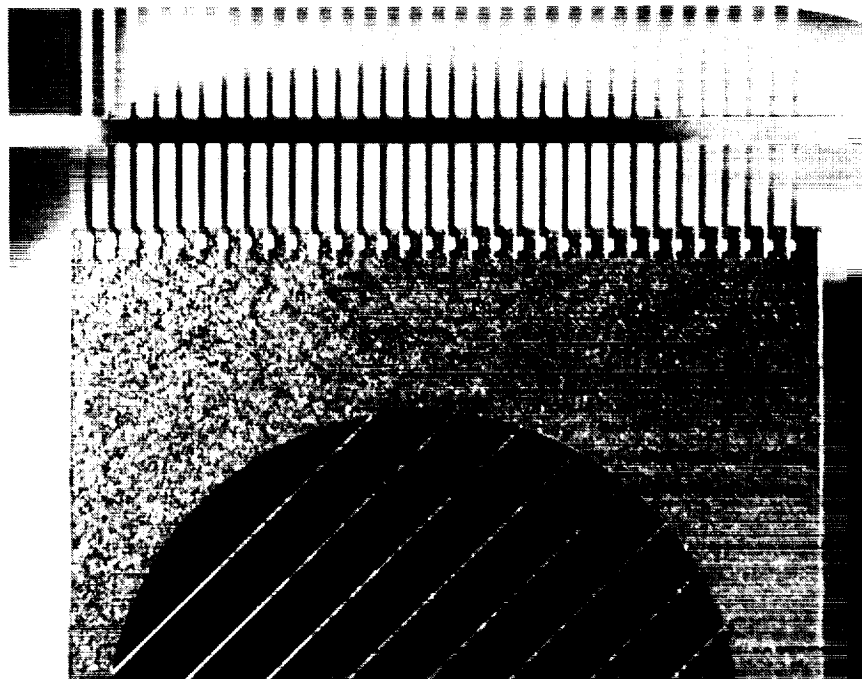

*Figure 2. Closeup of ILBs and TAB Tie Bar*

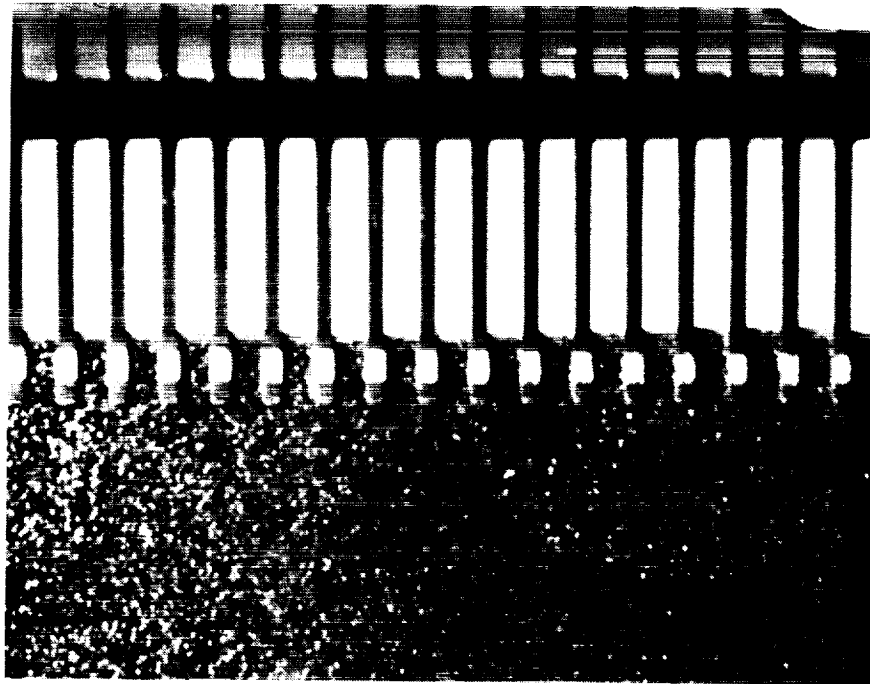

*Figure 3. TABed Lead 3-Mil Wide on 8-Mil Centers*

#### PRODUCTION IDEAS

Slide carriers offer a method of handling one TAB frame at a time, (see figure 4). This allows sorting the cell after flash testing, prior to lead forming. The disadvantage to the slide carrier is its added cost. The cost to load single TAB frame into the carrier, the carrier itself and extra capital equipment for sorting TABed Cells. The alternative method is to work with a group of TAB frames. For example; cut off group of ten from a TAB tape reel, ILB all ten fronts first, flip and push cell through, then bond all ILB backs. All ten then could be flash tested at once. The problems with this method are first, TAB tape is not a 100% yield product. Each strip of ten TAB frames could have a couple of bad frames. In addition post ILB flash testing may reject additional cells. Inventory of cells according to efficiency could be a problem.

#### EXCISE & FORMING

Post ILB, the concentrator solar cell needs to be excised from the TAB tape and the leads be formed for stress requirements. A single die was designed by the Prototype Development Lab and machined using wire EDM to do both excising and forming in one operation, (see figures 5, 6 and 7). This operation although manual can be automated with common SMT tooling and equipment.

After the die for excise and forming was made it had to be functionally tested. First, the shear was tested using cigarette paper instead of copper. Once quality shearing in the paper was achieved, copper strips were used. Paper can also indicate incorrect clearances in the forming feature relationships. The paper will be torn if the die is pinching. Next a dummy cell with a bonded tape was tested in the die set. After successful excise and forming was indicated, a real cell with correct bonds was tried. Minor adjustments were needed along with some shimming under the die to acquire consistent shearing. Generally, most difficulty was encountered in the shear function; the forming feature worked well from the onset.

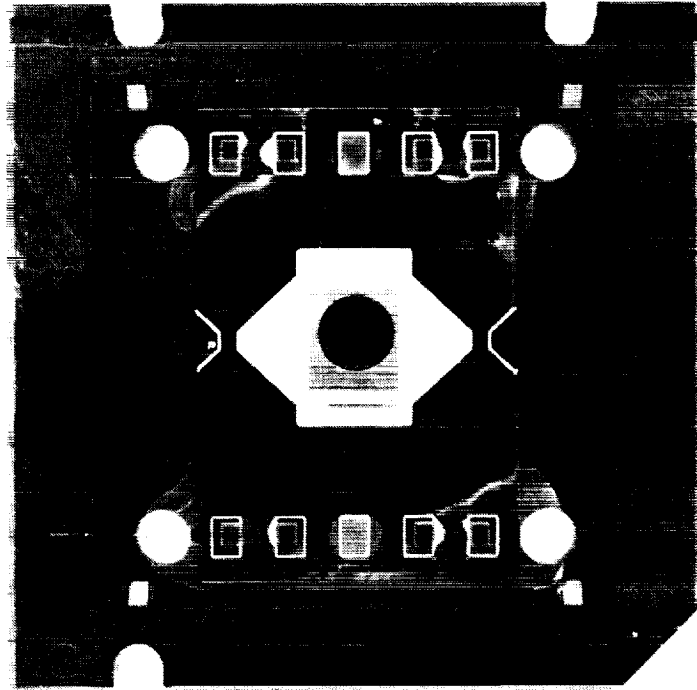

*Figure 4. TAB Slide Carrier With Concentrator GaAs Solar Cell*

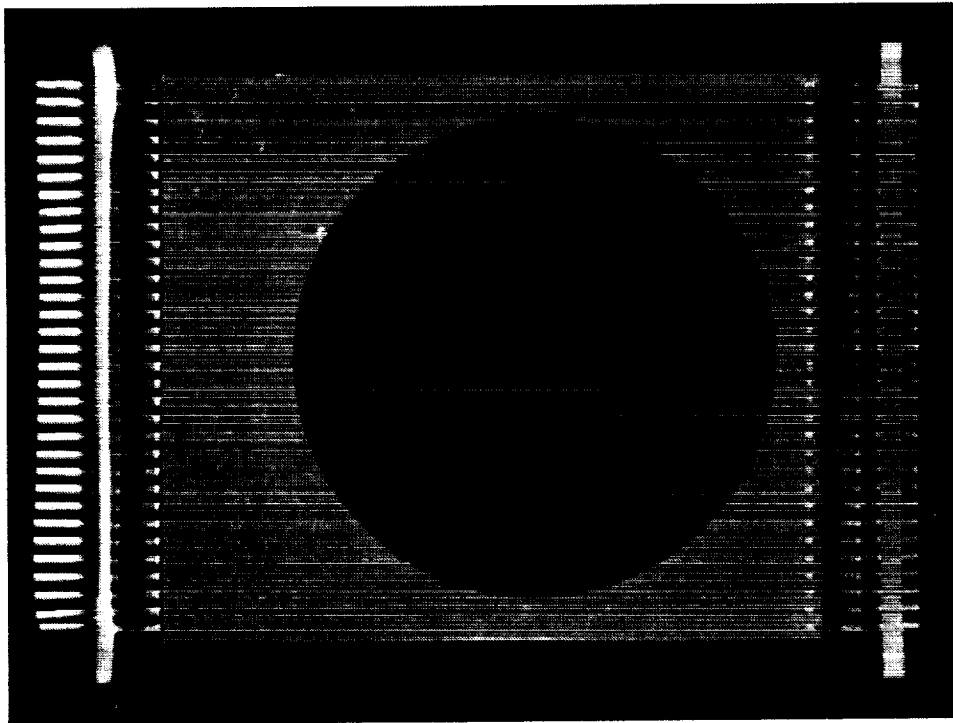

*Figure 5. Top View of Cell After Excise and Forming Operation*

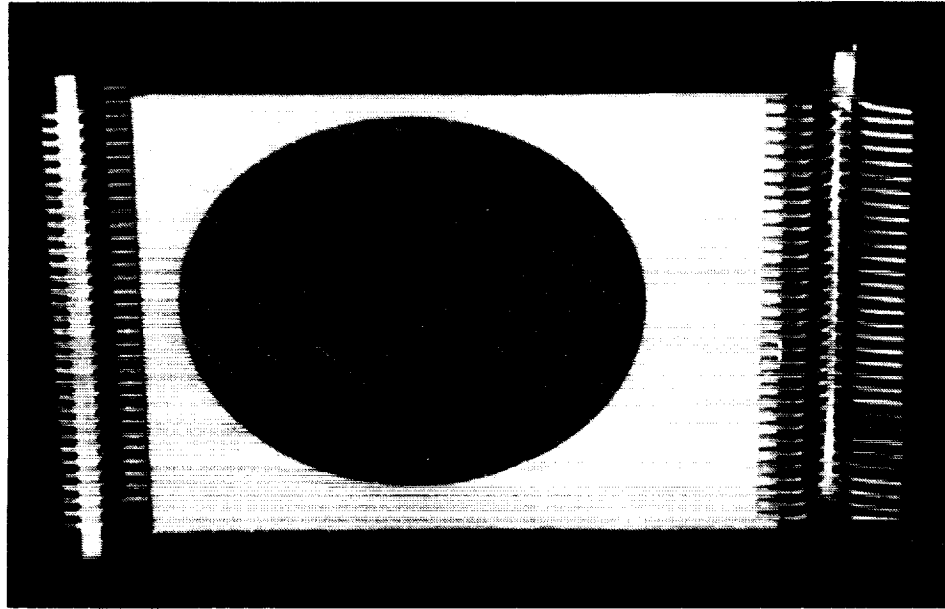

Figure 6. Excised and Formed Rotated For View of Stress Loop

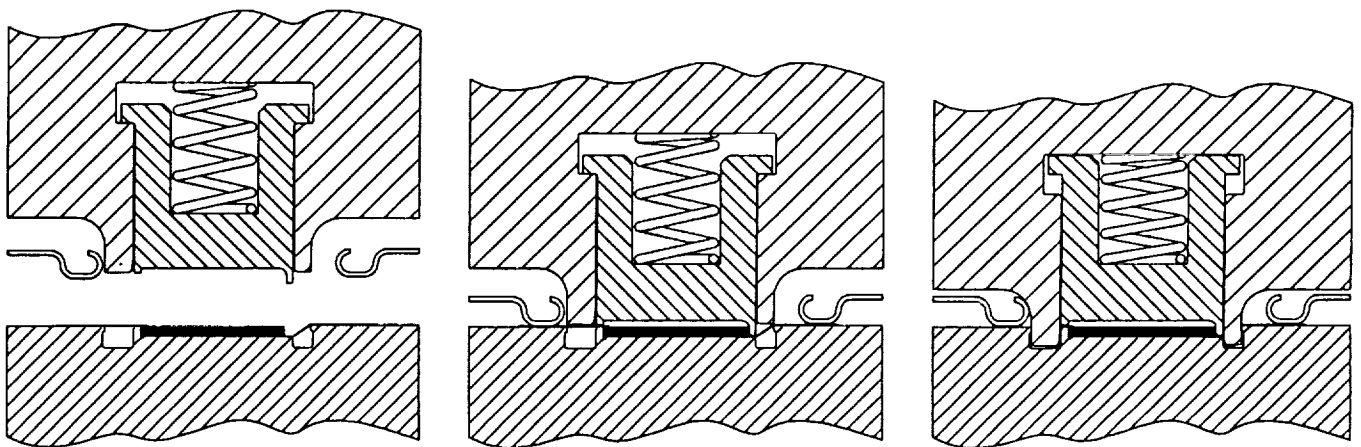

Figure 7. Excise and Form Tooling Sequence

#### PICK & PLACE

Once the solar cell leads are excised and formed, they need to be picked and placed to their respective locations on a flex circuit. At first this was done with a tooling microscope. This was fine for prototypes however it was time to evaluate automation. The concentrator solar cell placement required placement accuracies of  $\pm 0.005$  inches in order to maintain alignment with the focusing lenses.

A 12 cell flex circuit was fabricated at Boeing's flex circuit facility. It consisted of a 3-mil aluminum backing sheet, laminated with polyimide and copper. The copper was nickel flashed and gold plated. This circuit was placed on an EPE 20/20i gantry style x-y-z-theta pick and place machine with pattern recognition. The Boeing EPE 20/20i is capable of  $\pm 0.001$ " accuracy for alignment of top and bottom tandem cells on the flex circuit. The pick and place system was taught

were to find low  $\epsilon$  epoxy preforms and TABed solar cells in a waffle pack and to look for fiduciaris on the flex circuit. Epoxy TABed preforms were first picked, aligned and placed on a preheated flex circuit. the solar cells were then picked, aligned and placed atop the epoxy. Parallel gap welding the outer lead bonds completed the 12 cell solar cell circuit (see figure 8).

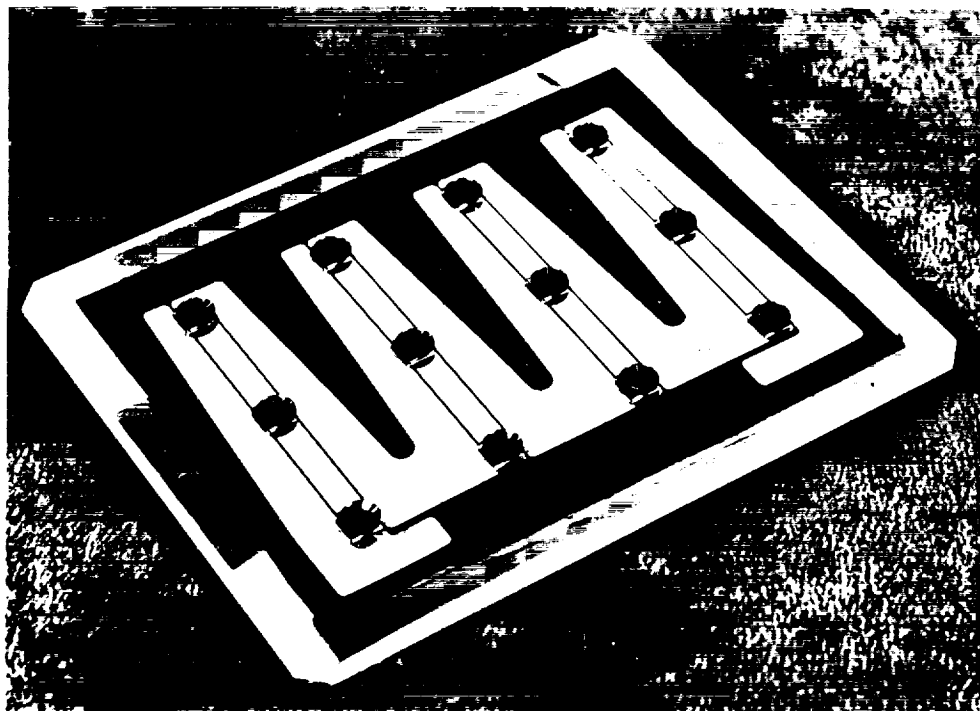

*Figure 8. TAB Concentrator Solar Cells, Assembled on Flex Circuit, Topped With Optical Secondaries*

#### CONCLUSIONS

The results of the flash testing on Boeing/Spectrolab concentrator solar cells are encouraging. No degradation has been observed on the new cells post ILB. Thermal cycle results on former 1 sun cells with silver contacts indicate a need for a barrier layer under the bond site to inhibit copper migration into the junction. Thermal cycle studies of silver-copper-tin ILBs will begin to evaluate the new Boeing/Spectrolab cells.

Preliminary evaluations of utilizing SMT pick and place technology for concentrator solar cell placement is encouraging. This technology is also being considered for placement of optical secondaries on production spacecraft contracts. One advantage of the EPE 20/20i machine is the ability to make a video record of each cell bond & placement for later review and record keeping.