

**NASA
Technical
Paper
3320**

July 1993

*IN-24
185016
15P*

Proposed Framework for Thermomechanical Life Modeling of Metal Matrix Composites

Gary R. Halford,
Bradley A. Lerch,
and James F. Saltsman

(NASA-TP-3320) PROPOSED FRAMEWORK
FOR THERMOMECHANICAL LIFE MODELING
OF METAL MATRIX COMPOSITES (NASA)
15 p

N94-12449

Unclas

H1/24 0185016

NASA

[The left page of the document is almost entirely obscured by dense, horizontal black lines, likely due to severe scanning artifacts or intentional redaction. Only faint, illegible traces of text are visible through the noise.]

[The right page of the document is also almost entirely obscured by dense, horizontal black lines, similar to the left page. The text is completely illegible due to the heavy noise and redaction.]

NASA
Technical
Paper
3320

1993

Proposed Framework for Thermomechanical Life Modeling of Metal Matrix Composites

Gary R. Halford,
Bradley A. Lerch,
and James F. Saltsman
Lewis Research Center
Cleveland, Ohio



National Aeronautics and
Space Administration
Office of Management
Scientific and Technical
Information Program

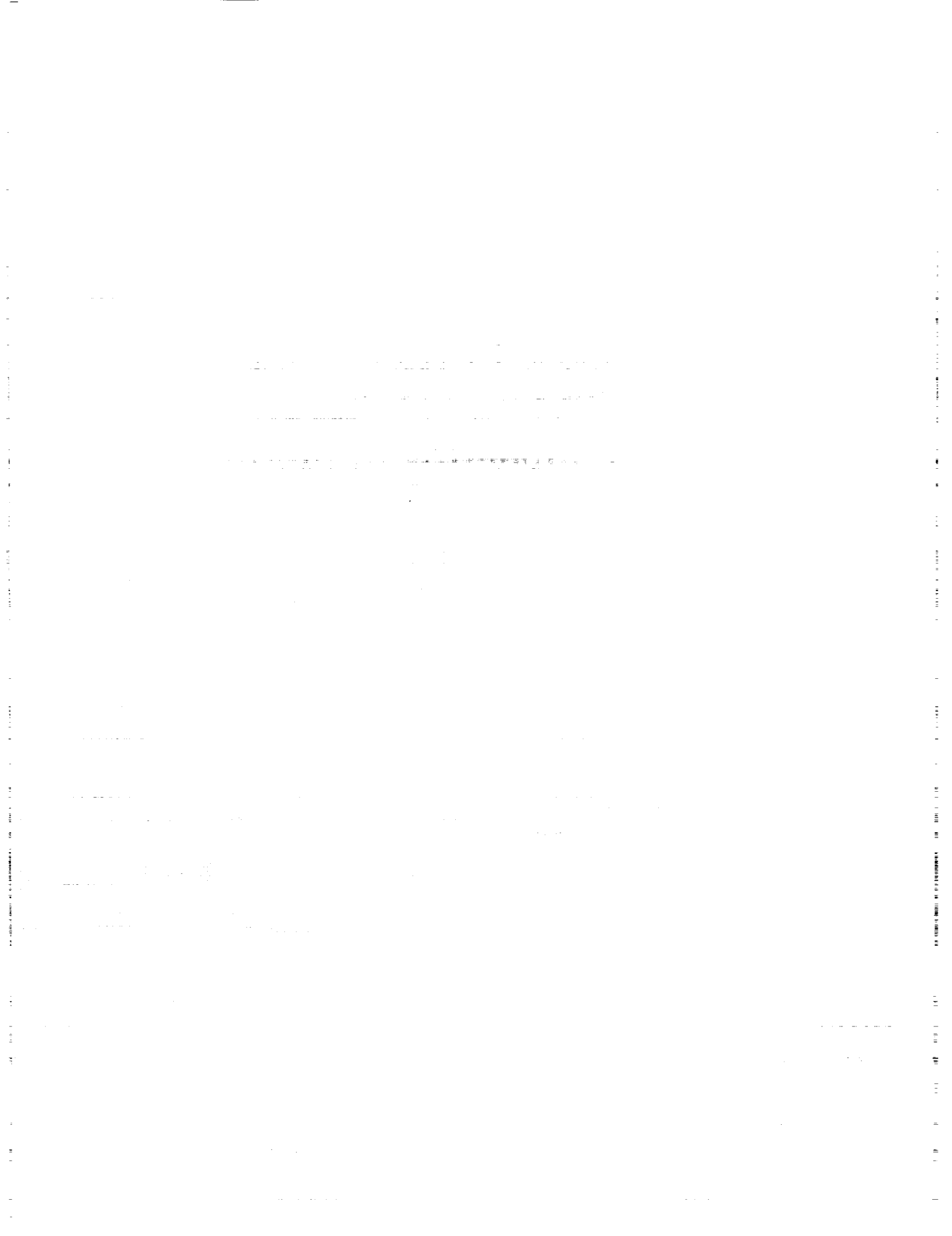

Summary

The framework of a mechanics of materials model is proposed for thermomechanical fatigue (TMF) life prediction of unidirectional, continuous-fiber metal matrix composites (MMC's). Axially loaded MMC test samples are analyzed as structural components whose fatigue lives are governed by local stress-strain conditions resulting from combined interactions of the matrix, interfacial layer, and fiber constituents. The metallic matrix is identified as the vehicle for tracking fatigue crack initiation and propagation.

The proposed framework has three major elements. First, TMF flow and failure characteristics of in situ matrix material are approximated from tests of unreinforced matrix material, and matrix TMF life prediction equations are numerically calibrated. The macrocrack initiation fatigue life of the matrix material is divided into microcrack initiation and microcrack propagation phases. Second, the influencing factors created by the presence of fibers and interfaces are analyzed, characterized, and documented in equation form. Some of the influences act on the microcrack initiation portion of the matrix fatigue life, others on the microcrack propagation life, while some affect both. Influencing factors include coefficient of thermal expansion mismatch strains, residual (mean) stresses, multiaxial stress states, off-axis fibers, internal stress concentrations, multiple initiation sites, nonuniform fiber spacing, fiber debonding, interfacial layers and cracking, fractured fibers, fiber deflections of crack fronts, fiber bridging of matrix cracks, and internal oxidation along internal interfaces. Equations exist for some, but not all, of the currently identified influencing factors. The third element is the inclusion of overriding influences such as maximum tensile strain limits of brittle fibers that could cause local fractures and ensuing catastrophic failure of surrounding matrix material. Some experimental data exist for assessing the plausibility of the proposed framework.

Symbols

B	intercept of elastic strainrange-life relations
C	intercept of inelastic strainrange-life relations
C'	intercept of inelastic line for combined creep-fatigue cycles

CC	creep strain in tension, creep strain in compression
CP	creep strain in tension, plastic strain in compression
F	inelastic strain fraction
K	cyclic strain-hardening coefficient
k	coefficient
MF	multiaxiality factor
N	number of applied cycles
PC	plastic strain in tension, creep in compression
PP	plastic strain in tension, plastic strain in compression
R	ratio, algebraic minimum to maximum
TF	triaxiality factor
V	ratio, mean to alternating
Δ	range of variable
ϵ	strain
Γ	ratio, absolute value of the compressive to tensile flow strengths evaluated at their respective temperatures and strain rates, preferably from cyclic isothermal or bithermal experiments
σ	stress

Subscripts

cc	creep strain in tension, creep strain in compression
cp	creep strain in tension, plastic strain in compression
eff	effective
el	elastic
f	failure with zero mean stress

<i>fm</i>	failure with mean stress
<i>i</i>	microcrack initiation with zero mean stress
<i>ij</i>	pp, pc, cp, or cc
<i>in</i>	inelastic
<i>L</i>	load
<i>p</i>	microcrack propagation with zero mean stress
<i>pc</i>	plastic strain in tension, creep in compression
<i>pp</i>	plastic strain in tension, plastic strain in compression
<i>t</i>	total
<i>y</i>	yield (0.2 percent offset)
ϵ	strain
σ	stress
Superscripts	
<i>b</i>	power for elastic strainrange-life relations
<i>c</i>	power for inelastic strainrange-life relations
<i>n</i>	cyclic strain-hardening exponent ($\approx b/c$)

Introduction

Low resistance to thermomechanical fatigue (TMF) is expected to be a limitation to the use of continuous-filament, metal matrix composites (MMC's) material systems in high-temperature applications. This is because an MMC will experience cyclic stresses and strains from three sources (fig. 1) rather than only two, like conventional monolithic alloys. The potential TMF degradation is particularly severe when the phasing of thermal and mechanical loadings causes the three strain contributors to have the same algebraic sign.

Typically, the coefficient of thermal expansion (CTE) of the fibers is considerably different (lower) than that of the matrices. Thus, when the temperature of an MMC material is changed, opposing internal thermal stresses and strains are distributed between the constituents in a manner consistent with equilibrium, compatibility, and constitutive stress-strain relations of fiber, matrix, and interfacial material.

The thermal expansion mismatch imposes deleterious stresses and strains within the matrix, fiber, and interface,

even in the absence of mechanical loads or conventional thermal-strain-inducing temperature gradients. Thus, structural components made of an MMC with a sizeable CTE-mismatch and operating over a large temperature range will experience a potentially large range of internal cyclic mechanical strain.

Consequently, component design procedures will mandate use of engineering structural analyses and durability models in attempts to mitigate the effects of potential TMF degradation in MMC's. This report presents a framework for performing fatigue life analyses of MMC's for thermal and thermomechanical loading.

Proposed Framework for TMF Life Prediction Model

General Description

A framework is presented for an engineering model that addresses the key durability issues involved in the TMF resistance of continuous-fiber, $[0^\circ]$ MMC's for high-temperature application. Axially loaded MMC material specimens are treated as conventional ministructures (fig. 2) whose weakest, most highly stressed links are the origins of fatigue cracking. As with conventional structures, the TMF durability of an MMC is expected to be governed by localized stress, strain, and temperature conditions, and their cyclic fluctuation with time. Linear elastic and nonlinear viscoplastic structural analysis techniques applicable to thermally cycled MMC's are under development (refs. 1 to 4).

If the reinforcing fibers are brittle ceramic, they would not be expected to be prone to cycle-dependent fatigue or time-dependent creep. Nor would one expect brittle interfacial layer material to undergo these classical mechanisms of degradation. Cracking occurs in these constituents, but the cracks initiate, grow, and arrest according to brittle fracture criteria. Thus, insofar as modeling damage initiation and propagation by cycle-dependent fatigue and time-dependent creep are concerned, we focus our attention on the ductile metallic matrix material. The matrix is used as the vehicle for tracking fatigue damage evolution.

The proposed framework consists of three major elements:

(1) The TMF equations that approximate the in situ matrix material are calibrated from test results of unreinforced matrix material. The measured macrocrack initiation fatigue life (failure of coupon-sized axial specimen) of the matrix material is partitioned into microcrack initiation and microcrack propagation phases in accordance with proposed equations.

(2) The influencing factors created by the presence of fibers and interfaces are analyzed, characterized, and documented in equation form. Some of the influences act on

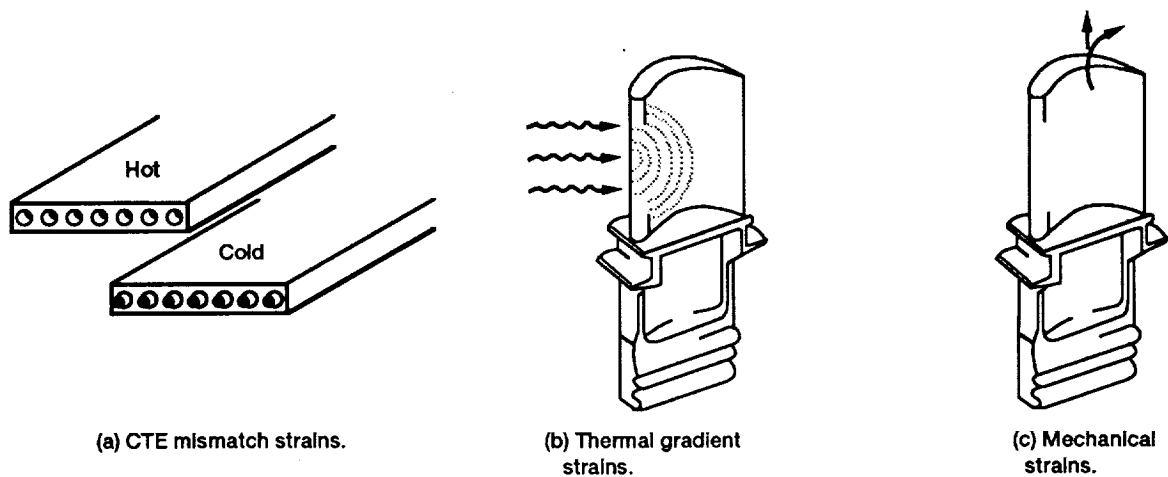

Figure 1.—Triple contributions to stresses and strains in thermal fatigue of MMC's, including coefficient of thermal expansion mismatch, thermal gradients, and applied mechanical loading.

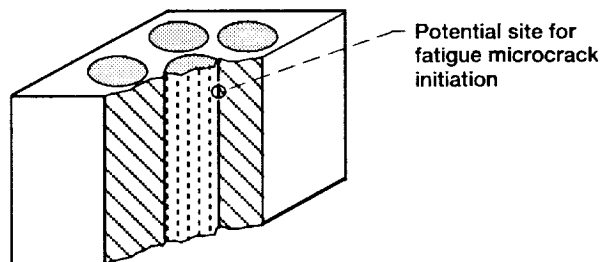

Figure 2.—Composite material as ministructure.

the microcrack initiation portion of the matrix fatigue life, others on the microcrack propagation life, while some affect both. Influencing factors will be discussed in a later section.

(3) The overriding influences such as a maximum tensile strain limit of brittle fibers that could cause individual fiber fractures and ensuing catastrophic failure of the surrounding matrix are recognized and accounted for.

Some experimental data are available to assess the potential capability of the proposed framework.

TMF Failure Behavior of Matrix

Since isothermal fatigue and creep-fatigue behavior alone may be insufficient for estimating fatigue behavior under thermal cycling conditions (ref. 5), the matrix material's baseline failure behavior should be characterized through thermal, rather than isothermal, cycling experiments. We recommend using bithermal-cycling experiments as proposed in reference 6 and adopted in the thermomechanical fatigue (TMF) life prediction model (ref. 7) based on the concepts of the total strain version of strainrange partitioning (TS-SRP) (refs. 8 and 9). The applicability of the TMF/TS-SRP approach has been verified recently for two high-temperature

aerospace superalloys: cast B-1900 + Hf and wrought Haynes 188 (ref. 10).

Bithermal test results are used to establish the constants in the matrix TMF life prediction equation. Bithermal fatigue (in-phase and out-of-phase PP) and bithermal creep-fatigue (in-phase CP and out-of-phase PC) experiments (ref. 6) produce hysteresis loops of the types shown in figure 3. The term "creep-fatigue" is used since the cycles emphasize creep deformation superimposed on strain-limited fatigue cycling. Since the tests typically are performed on specimens in a laboratory air atmosphere, they are also subject to oxidation. For present purposes, it is to be understood that "creep-fatigue" experiments in air produce results that reflect the interactions of all three important failure behavior factors: fatigue, creep, and oxidation. Failure behavior is not particularly sensitive to the exact details of the wave shape of the cycle, provided the partitioning of the inelastic strains is similar.

TMF Constitutive Flow Behavior of Matrix

In addition to documentation of bithermal fatigue and creep-fatigue failure characteristics, it is also necessary to establish the cyclic viscoplastic flow behavior of the matrix.

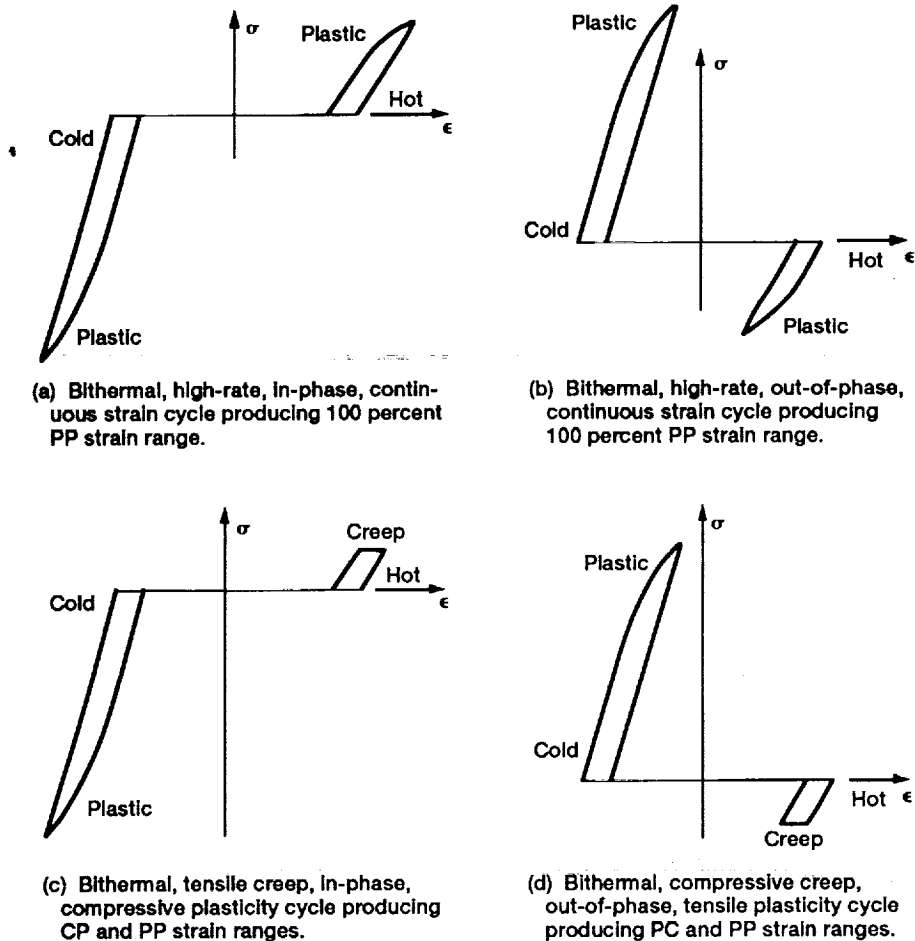

Figure 3.—Schematic stress-strain hysteresis loops for bithermal fatigue and creep-fatigue.

A particularly advantageous feature of the currently proposed TMF life prediction approach is its ability to be applied to any generalized time- and temperature-dependent TMF cycle. This is achieved through the use of any one of numerous unified viscoplastic models that have been proposed over the last decade. Evaluation of the constants in these frequently complex evolutionary-type constitutive equations remains a serious problem that has limited their widespread use. The procedures are not always straightforward. Furthermore, the precisely appropriate data may not be readily available without performing additional experiments. Nonetheless, considerable cyclic flow results are automatically made available during the performance of the bithermal failure behavior tests. These results and supplemental test results, as necessary, depending on the selected flow model, are used to evaluate the constants in a cyclic viscoplastic model. Among the unified viscoplastic constitutive models used successfully in various NASA Lewis Research Center programs are the models proposed by Bodner and Partom (ref. 11), Walker (ref. 12), Robinson and Swindeman (ref. 13), and Freed (ref. 14). Considerable research remains to develop reliably accurate models that are easy to calibrate and implement into finite element structural

analysis and life prediction codes. On occasion, we have resorted to simpler, less general, empirical, power-law relations to document the required cyclic flow behavior for use with the current TMF life prediction method (refs. 7 and 8). In these instances, because of the sensitivity of the flow behavior to details of the wave shape, it is necessary to use a wave shape for flow behavior documentation that is similar to the mission cycle being analyzed.

Failure Behavior Equations for Matrix

Macrocrack Initiation. — Once the flow and failure characteristics of the matrix material have been established, the total mechanical strainrange versus fatigue life equation (macrocrack initiation life \equiv fatigue life of coupon-sized axial specimen) can be written for any arbitrary in-phase or out-of-phase TMF cycle.

Figure 4 shows the total mechanical strainrange versus fatigue life relation for matrix material based on the TS-SRP representation. Pertinent equations are shown in the figure. Step-by-step procedures for the calibration of the constants in the subject equations for TMF are given in reference 7. It is

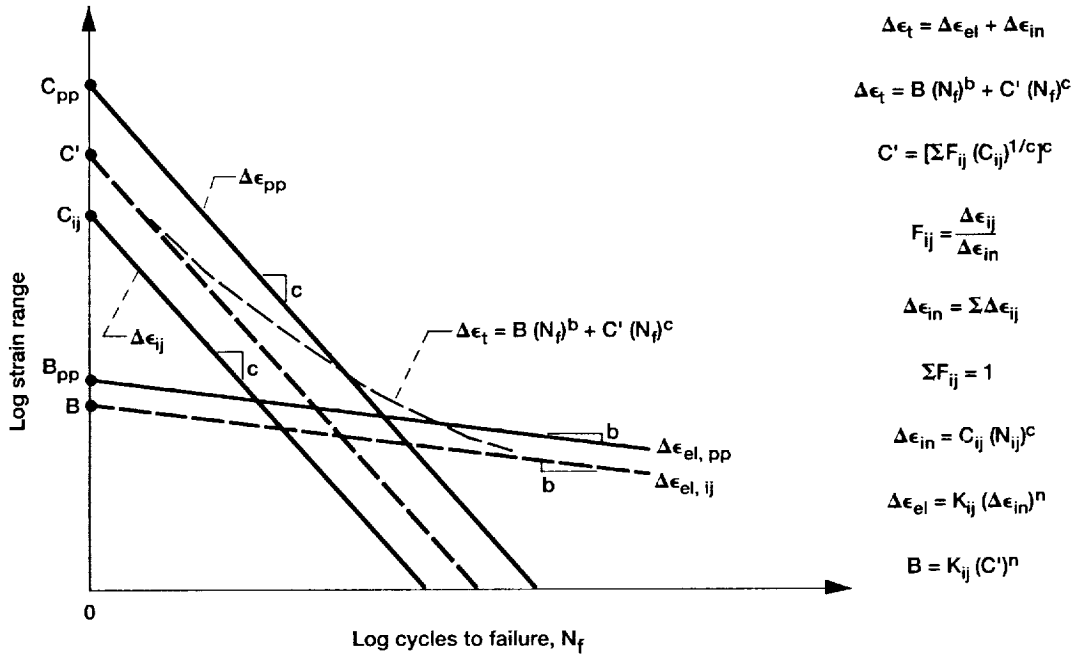

Figure 4.—TMF fatigue life equations and low-cycle fatigue curve for matrix material (condensed from ref. 7, ij = pp, pc, cp, cc).

important to realize that the resultant TMF life prediction equation is for the matrix material and is applicable for the specifically stated loading condition; that is, the exact temperature and strain versus time history, or a reasonable approximation, is prescribed. Should a different set of loading conditions be imposed, a new set of equation constants are to be calculated from the calibrated flow and failure characteristics.

The TMF life prediction equation shown at this stage represents conditions involving no fibers, no geometric discontinuities (i.e., no stress concentrations), zero mean stress, a uniaxial stress-strain state, and continuously repeated loadings of constant total strain range, frequency, temperature range, and so on. Modifications of the equation to deal with specific influencing factors associated with a composite are discussed in the section Influences of Fibers on Matrix Properties and Behavior. Some of the influences can be described analytically, and quantitative computations of the expected effect on TMF life are possible. Other influences are not as yet at the quantifiable stage, and for the meantime will require empiricism and calibration of computations with experimental TMF results.

Some of the influencing factors of the fibers will affect microcrack initiation more than microcrack propagation, and vice versa. It is convenient therefore to distinguish, analytically, these two important components of the total macrocrack initiation life.

As a starting point, we will assume that the relative proportions of microcrack initiation and propagation in TMF are similar to isothermal fatigue. Approximate equations for the

microcrack initiation and propagation portions of the total fatigue life are suggested as follows. First, the total strain range can be decomposed into its elastic and inelastic strainrange components,

$$\Delta \epsilon_t = \Delta \epsilon_{el} + \Delta \epsilon_{in} \quad (1)$$

Power-law relations between strainrange components and fatigue life (zero mean stress conditions) are commonly observed; i.e.,

$$\Delta \epsilon_{el} = B(N_f)^b \quad (2)$$

and

$$\Delta \epsilon_{in} = C(N_f)^c \quad (3)$$

Thus, for macrocrack initiation,

$$\Delta \epsilon_t = B(N_f)^b + C(N_f)^c \quad (4)$$

Microcrack initiation and propagation. — Macrocrack initiation fatigue life can be decomposed into microcrack initiation and microcrack propagation phases,

$$N_f = N_i + N_p \quad (5)$$

There is widespread acceptance of the notion that microcracks initiate very early in low-cycle fatigue (LCF), leaving the vast majority of life to be spent in microcrack propagation. Furthermore, in high-cycle fatigue, microcracks initiate late in life and the microcrack propagation phase is a small fraction of the total life. Although somewhat arbitrary, it is not unreasonable to assume that, at the lowest possible life of $N_f = 1$,

$$N_i \approx 0.1N_f \quad (6a)$$

$$N_p \approx 0.9N_f \quad (6b)$$

and, at an arbitrarily high cyclic life of $N_f = 10^7$,

$$N_i \approx 0.9N_f \quad (6c)$$

$$N_p \approx 0.1N_f \quad (6d)$$

Simple power-law equations can be written relating N_i to N_f and N_p to N_f by using the respective sets of coordinates of equations (6a and b) and (6c and d). The resultant equations, when substituted into equation (4) with $b = -0.12$ and $c = -0.60$ (ref. 15), yield the following relations between total mechanical strain range and microcrack initiation and propagation lives:

For microcrack initiation,

$$\Delta\epsilon_i \approx 0.80B(N_i)^{-0.10} + 0.34C(N_i)^{-0.50} \quad (7)$$

For microcrack propagation,

$$\Delta\epsilon_p \approx 1.30B(N_p)^{-0.14} + 1.14C(N_p)^{-0.70} \quad (8)$$

Influences of Fibers on Matrix Properties and Behavior

The fact that fibers are present in a composite imparts changes in both the flow and failure response of the matrix. A fully developed MMC life prediction method must deal directly with these induced changes. A listing of the most significant mechanical influences on the surrounding matrix is given in table I. Each factor is identified as to whether it influences the microcrack initiation or microcrack propagation phases of the macrocrack initiation life. A few of the influences can be handled analytically, others require development. Currently identified influences are discussed in the following paragraphs.

TABLE I.—FACTORS ASSOCIATED WITH FIBERS MECHANICALLY INFLUENCING MATRIX FATIGUE RESPONSE

Factor	N_i	N_p
CTE mismatch strains	Yes	Yes
Residual (mean) stresses	↓	↓
Multiaxial stress state	↓	↓
Off-axis fibers	↓	↓
Internal stress concentrations	↓	No
Multiple initiation sites	↓	Yes
Nonuniform spacing	↓	Yes
Interfacial layers	↓	No
Fractured fibers	↓	No
Fiber debonding	No	Yes
Fiber crack retardation	No	Yes
Fiber bridging	No	Yes

Effects of Fibers and Interfaces on Matrix Flow and Failure

CTE mismatch strains.—One of the largest influences on the cyclic strains induced in the matrix of an MMC under TMF loading is the mismatch between the fiber and matrix coefficients of thermal expansion. As shown in table II for three common MMC systems, the matrix CTE is larger than the fiber CTE by as much as two to four times. Based on the mechanics concepts of equilibrium, compatibility, and constitutive stress-strain response, Garmong (ref. 16) has presented analyses of the constituent stresses and strains in thermally loaded composites. Although Garmong dealt with eutectic composites, his analyses are directly applicable to [0°] MMC's.

Slow, uniform temperature cycling (with no externally applied load) of a typical [0°] MMC will induce a cyclic strain range in the matrix. Since the matrix is mechanically strained by the fibers as the temperature changes, the matrix undergoes a TMF cycle. The matrix TMF cycle is out of phase. Should the MMC also be loaded in an out-of-phase TMF cycle, the externally applied mechanical strain will add

TABLE II.—APPROXIMATE VALUES OF COEFFICIENTS OF THERMAL EXPANSION (CTE) AT ROOM TEMPERATURE OF MATRIX AND FIBER FOR THREE COMMON HIGH-TEMPERATURE COMPOSITE SYSTEMS

Composite system	Coefficient of thermal expansion, °C ⁻¹		
	W/Cu	SCS-6/Ti-15-3	SCS-6/Ti-24Al-11Nb
Matrix	16.0×10 ⁻⁶	9×10 ⁻⁶	12×10 ⁻⁶
Fiber	4.4	4.9	4.9

directly to the internally induced mechanical CTE mismatch strain. The resultant increased strain range in the matrix will lower the macrocrack initiation life of the matrix in accordance with equation (4). On the other hand, if the MMC is subjected to in-phase TMF loading, the two matrix strain contributions will tend to subtract from one another depending on the exact details of the phasing of temperature and strain. For isothermal fatigue at room temperature, the CTE mismatch strain caused by cooling from a fabrication/heat treatment temperature usually produces a tensile residual stress in the matrix that will act as a mean stress in subsequent fatigue loading, provided the residual stress does not relax because of inelasticity in the matrix.

Mean stress effects.—Procedures for dealing with mean stresses (due to residual stresses or actively applied mean loads) in strain-based fatigue life models are covered in reference 7. The currently adopted mean stress model is based on a modification (ref. 17) of the Morrow mean stress approach (ref. 18). The following equation can be derived from Morrow's approach. It has direct applicability to isothermal, nominally elastic cyclic loading conditions.

$$(N_{fm})^{-b} = (N_f)^{-b} - V_\sigma \quad (9)$$

V_σ , the ratio of mean to alternating stress, is equal to the inverse of the classical A ratio for fatigue. For strain-controlled cycles involving detectable amounts of inelasticity, any initially present mean stresses will tend to cyclically relax, numerically reducing the value of V_σ . During creep-fatigue loading, the numerical value of V_σ may be nonzero, yet should not be expected to affect cyclic life in a conventional mean stress manner. Consequently, an effective V_σ was defined in reference 17 as $V_{\text{eff}} = kV_\sigma$, where $k \rightarrow 0$ for $\Delta\epsilon_{in}/\Delta\epsilon_{el} \rightarrow 0.2$ and larger, and $k \rightarrow 1$ for $\Delta\epsilon_{in}/\Delta\epsilon_{el} \rightarrow 0$.

The effective mean stress ratio V_{eff} for nonisothermal conditions has been proposed (ref. 5) to take the form

$$V_{\text{eff}} = \frac{1 + \frac{R_\sigma}{\Gamma}}{1 - \frac{R_\sigma}{\Gamma}} \quad (10)$$

where Γ is a strength ratio defined in the Symbols section.

Accurate calculation of matrix mean stresses requires accurate nonlinear structural analysis procedures and viscoplastic constitutive modeling of the matrix material. Mean stress can affect the fatigue macrocrack initiation resistance of MMC's by more than an order of magnitude in cyclic life. For example, for an isothermal, nominally elastic case with $b = -0.12$, $V_\sigma = 1.0$ (and a corresponding life with zero mean stress, $N_f = 100\,000$), the fatigue life N_{fm} is calculated from equation (9) to be less than 9000 cycles to failure.

Multiaxiality of stress.—Fibers cause multiaxial stress-strain states within the matrix (even though the loading on the unidirectional MMC is uniaxial) as a result of their differing elastic and plastic stress-strain properties, and their differing thermal conductivities and expansion coefficients. Any deviation from uniaxial loading can be handled by using any of a number of multiaxiality rules proposed in the literature. A relatively simple procedure for calculating the life-influencing effects of multiaxial stress states is given by Manson and Halford (refs. 19 and 20). The approach is based on von Mises effective stress-strain and the multiaxiality factor MF (a measure of the degree of hydrostatic stress normalized by the corresponding von Mises effective stress). The equation for the multiaxial factor is

$$MF = TF \quad TF \geq 1 \quad (11a)$$

$$MF = \frac{1}{2 - TF} \quad TF \leq 1 \quad (11b)$$

where

$$TF = \left[(\sigma_1 + \sigma_2 + \sigma_3) / (1/\sqrt{2}) \right] \times \left[(\sigma_1 - \sigma_2)^2 + (\sigma_1 - \sigma_3)^2 + (\sigma_2 - \sigma_3)^2 \right]^{1/2} \quad (11c)$$

and σ_i = principal stresses ($i = 1, 2, 3$).

While multiaxial stress-strain states are always present in thermally cycled MMC's, their effect on cyclic durability of axially loaded [0°] MMC's does not appear to be exceptionally great, at least for the degrees of multiaxiality that are self induced (as opposed to externally imposed multiaxial loading). The multiaxiality factor for unidirectional loading of a unidirectional fiber layup for the SCS-6/Ti-15-3 MMC system was determined to be only 1.04 (ref. 4). Multiplying 1.04 times the computed effective strain range yields the strain range for entering the matrix total strainrange versus macrocrack initiation life equation. This would give rise to a calculated decrease in fatigue life of only about 10 percent.

Off-axis fibers.—Using data for an E-glass fiber/polymeric matrix composite, Hashin and Rotem (ref. 21) analyzed the influence of off-axis fibers. As an example of their analytical and experimental findings, a shift from a 5° to a 10° off-axis loading showed a loss of a factor of approximately 2 in isothermal fatigue strength. The corresponding loss in cyclic lifetime was measurable in terms of multiple orders

of magnitude. A 60° off-axis loading resulted in a loss of nearly an order of magnitude in fatigue strength. Relatively small deviations from [0°] can be responsible for large losses in fatigue resistance. Although the example was for a polymeric matrix composite, MMC fatigue behavior would be expected to be comparable. Modifications to Hashin and Rotem's equations will be necessary to make their analysis compatible with the matrix strain-based approach under development herein.

Internal stress concentrations/multiple initiation sites. — An internal microstress concentration factor produces higher local internal stresses and strains and promotes earlier microcrack initiation. Once the microcrack grows away from the local concentration, however, the concentration effect would diminish and the microcrack propagation portion of life would be relatively unaffected. An internal stress-strain concentration factor can be multiplied times the calculated nominal stresses and strains, or the nominal strain range can be entered into a modification of equation (7) (wherein the coefficients 0.8 and 0.34 have been divided by the value of the concentration factor).

Internal crack initiation at local stress-strain concentrations can occur in MMC's at multiple initiation sites, thus leading to shorter paths for cracks to follow prior to linking together and hastening the macrofracture of the composite. If microcrack growth paths are decreased by an average of a factor of 2, it would be expected that the micropropagation phase of life would also decrease by a factor of 2.

Nonuniform fiber spacing. — The recent work of Bigelow (ref. 22) represents an excellent example of how structural analysis is used to determine the influence of non-uniform fiber spacing on the stress-strain response behavior of the in situ matrix. Using finite element structural analysis modeling of fabrication cool-down stresses in an MMC with uneven fiber spacing, Bigelow has been able to calculate that increased matrix stresses (longitudinal, radial, and hoop directions relative to fiber) result from decreasing local fiber spacing. Greater local stresses translate into increased ranges of local strain for cyclic temperatures. Hence, equation (7) would be used to predict the expected lower microcrack initiation life. Little effect on the microcrack propagation life would be expected for this influencing factor.

Interfacial layers. — Additional examples of using structural analyses to ascertain effects of fibers and interfaces on matrix stress-strain response are found in the work of Jansson and Leckie (ref. 23) and Arnold, Arya, and Melis (ref. 24) for assessing the influence of compliant interfacial layers between fibers and matrix.

Additional influencing factors associated with cracks or debonding. — Further analytic development of the proposed framework will be required to quantitatively model the impact on microcrack propagation life of some of the influencing factors not yet discussed. Of particular interest are those factors directly associated with microcracks within an MMC, that is, fractured fibers and fiber debonding (the concepts proposed by Chen and Young (ref. 25), among others,

offer a promising approach), fiber crack retardation, and fiber bridging (see applicable work of Ghosn, Kantzos, and Telesman (ref. 26)).

Once determined, the induced stresses and strains from any of the influences discussed here are expected to alter the matrix failure behavior in accordance with experience on monolithic metallic materials; that is, local increases in strain range will reduce N_i , higher tensile mean stresses will decrease N_i , a higher multiaxiality factor will reduce N_i , and so on. The more highly localized is the stress and strain, the less likely a significant influence will be expected on N_p .

Metallurgical interactions. — The presence of distributed nonmetallic fibers can also influence the metallurgical state of the matrix material. Heat treating of the matrix in the presence of fibers can result in a somewhat different microstructure, yield strength, ultimate tensile strength, ductility, and hardness than obtained by heat treating unreinforced matrix metal (ref. 27). This influence will compound the problem of isolating the true cyclic flow and failure behavior of the in situ matrix material.

Another crucial factor is the potential for increased internal oxidation of the MMC made possible by the interfacial layers acting as diffusional pipelines within the interior of the MMC. Internal oxidation will dramatically reduce an MMC's TMF resistance by promoting early microcrack initiation and faster microcrack propagation.

TMF models with separate terms for cyclic oxidation damage interaction with creep and fatigue have been proposed recently by Nissley, Meyer, and Walker (ref. 28), Neu and Sehitoglu (refs. 29 and 30), and Miller, McDowell, and Oehmke (ref. 31). Perhaps features of these models can be adapted to the prediction of internal oxidation effects in high-temperature MMC's.

Mechanical Effects of Matrix on Fibers

It is also necessary to examine the mechanical influence of the matrix on the response characteristics of the reinforcing fibers. Fibers of primary concern are elastic and brittle. They fail progressively throughout the fatigue life of the MMC as a result of the continual shedding of tensile stresses from the matrix material as it cyclically deforms. Cyclic relaxation of mean (residual) stresses and strain hardening or softening of the matrix result in various scenarios of behavior depending on the combination of operative conditions.

Selecting the specific condition of zero-to-maximum tensile load control can aid in a qualitative micromechanics analysis of how the fibers are influenced by the matrix behavior. Cyclic tensile mean stress relaxation, as well as cyclic strain softening of the matrix, causes a shift of additional tensile stress (and hence, strain) to the fibers, pushing them closer to their critical fracture strain. If the matrix cyclically strain hardens, the matrix will tend to carry a larger portion of the total peak tensile load. This is counteracted, and possibly overshadowed, by the cyclic relaxation of any

initial tensile residual stresses. For all other things being equal, the case of cyclic strain softening of the matrix will tend to strain the fibers in tension to a greater extent than for cyclic strain hardening.

In addition to cyclic hardening, softening, and relaxation of mean stresses (either by cyclic or time-dependent means), fibers are forced to carry a greater portion of the imposed tensile load because of matrix cracking perpendicular to the fibers. As the matrix fatigues from microcrack initiation and microcrack propagation, more and more of the applied load is shed to the fibers in the plane of the cracks. Furthermore, as fibers begin to crack, the load they carried is transferred to the remaining unbroken fibers, thus increasing their peak tensile stresses and strains and pushing them closer to ultimate fracture. Failure of the composite into two pieces occurs at the point wherein the remaining axial fibers must carry stresses and strains in excess of their critical value. This important fact forms the basis for the "fiber-dominated" approach to composite life prediction proposed by Johnson (refs. 32 and 33). An integral part of the currently proposed TMF MMC life prediction method is the inclusion of an upper strain limit that will cover those conditions wherein the life of the material is clearly governed by the tensile strain capacity of the fibers. This is represented in figure 5 where a horizontal line is drawn at the value of the critical tensile fracture strain of the fiber. To properly place this strain value on a strainrange axis requires that a micro-mechanics strain analysis of the MMC be able to determine the initial mean strain in the fibers.

Comparison with Experimental Results

To date, there has been no direct experimental evaluation or verification of the proposed MMC modeling efforts. While

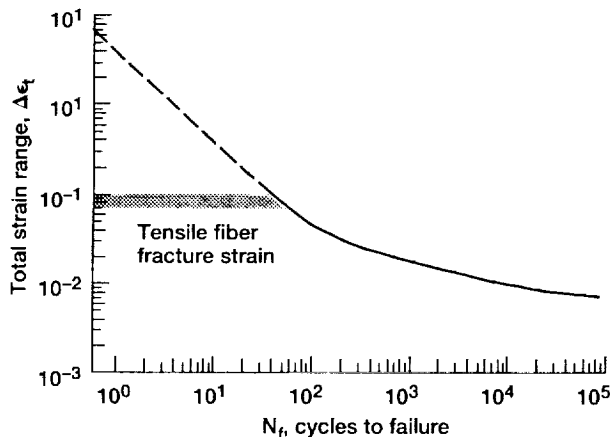

Figure 5.—Strain range versus fatigue life curve for MMC with brittle fiber.

TMF data for MMC's exist, the necessary matrix material property data required by the proposed TMF life prediction method have yet to be generated for these systems. Nevertheless, some isothermal fatigue results from the open literature for MMC's and their corresponding matrices have been examined in light of the currently adopted points of view. Examples of published isothermal results are available from NASA and Air Force programs for three commonly available materials: W/Cu (ref. 34), SiC/Ti-15-3-3-3 (ref. 35), and SiC/Ti-24Al-11Nb (refs. 36 and 37). The first example represents a ductile/ductile MMC system while the latter two represent brittle/ductile MMC and IMC (intermetallic matrix composite) systems, respectively.

Tungsten/Copper MMC

Strain-controlled, completely reversed, low-cycle fatigue test results have been reported by Verrilli and Gabb (ref. 34) for 9 and 36 vol. % W/Cu at 260 and 560 °C. They compared their 560 °C results to 538 °C isothermal data for both annealed and hardened copper generated by Conway, Stentz, and Berling (ref. 38). Figure 6, taken from reference 34, shows only slight differences in the strain-cycling fatigue resistance of the copper and the W/Cu MMC. This would imply that the numerous potentially detrimental effects on the matrix due to the presence of fibers are not realized under the current circumstances. This observation is consistent with several important aspects of this MMC system and its constituents. Because of the low strength and high ductility of the matrix, any detrimental original tensile residual stresses

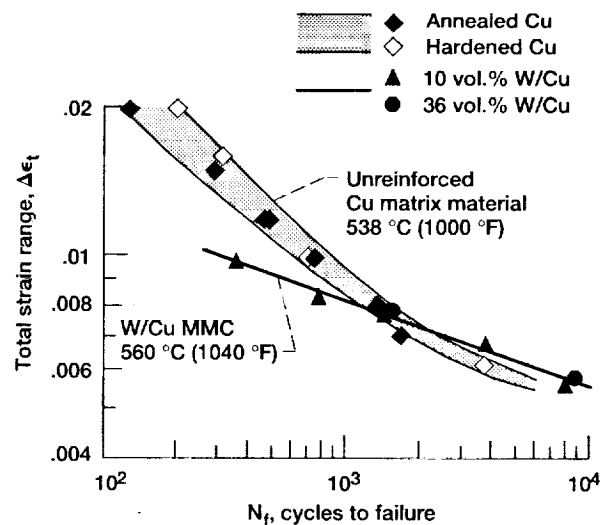

Figure 6.—Comparison of isothermal fatigue resistance of W/Cu MMC (ref. 34) with Cu unreinforced matrix material (ref. 38).

and any applied tensile mean stresses (MMC loading was zero-to-maximum tension) would have cyclically relaxed very rapidly at the strain levels of the experiments. The degree of multiaxiality in this system during isothermal loading is also quite small, and hence the MF may be too low to have a discernable effect on fatigue life. Large internal stress concentrations were not present, although 0.4- μm -sized voids apparently were introduced into the matrix during fabrication of the MMC. Fiber alignment and spacing were well controlled during the fabrication process. In addition, the fiber and matrix do not have a brittle interfacial reaction layer as the two elements chemically "wet" each other and form excellent bonds. Fibers are not brittle at elevated temperature, and hence cracked fibers are not a source of microcrack initiation. Furthermore, fibers do not debond from the matrix during axial loading, and fibers appear to prolong the life to a small degree at the longer life levels, perhaps because of the beneficial effects of crack retardation and crack bridging brought about by the excellent interfacial bond.

Silicon Carbide/Titanium MMC

Unpublished isothermal, load-controlled, low-cycle fatigue results for SCS-6/Ti-15-3 MMC have been generated in conjunction with a cooperative research program between NASA Lewis and Pratt & Whitney. These results, shown in figure 7, are for 427 °C (800 °F) with $R_L = 0$ and cyclic frequencies ranging between about 0.03 and 0.3 Hz, depending on strain range and testing laboratory. Fiber volume fractions range from 34 to 38 percent. The MMC results are compared with isothermal, strain-controlled, $R_\epsilon = -1$, data reported (ref. 35) for matrix material processed in the same fashion as the composite. Frequencies ranged between 0.03 and 1.0 Hz and were the highest at the lowest strain ranges. Substantially reduced strain fatigue resistance is exhibited by the MMC

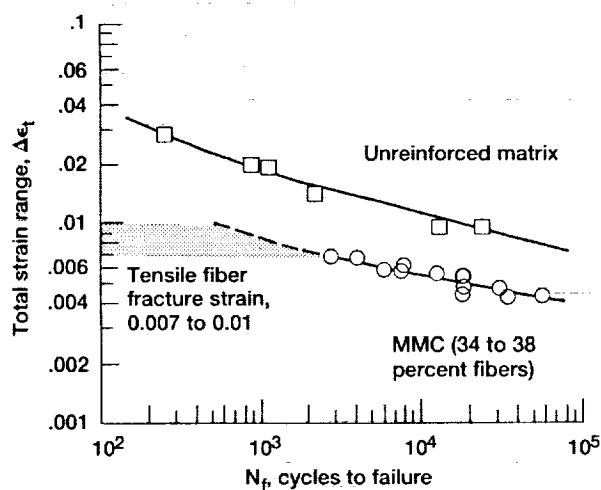

Figure 7.—Comparison of isothermal fatigue resistance of SCS-6/Ti-15-3 MMC (previously unpublished NASA and Pratt & Whitney data) with Ti-15-3 unreinforced matrix material (ref. 35).

when compared to the unreinforced matrix. The reduction is a factor of approximately 2 in strain range for a fixed life, or a factor of about 40 in life for a given strain range. Among the dozen influential factors previously discussed, few could be responsible for the significantly large loss in fatigue resistance caused by the presence of fibers in the Ti-15-3 matrix. The most pertinent influences are discussed in the following paragraphs.

Any mean stresses in the matrix that may be present because of either the nature of loading or the residual fabrication stresses are expected to cyclically relax to zero for Ti-15-3 at 427 °C (800 °F). Experimental results supporting this argument have been reported by Gayda, Gabb, and Freed (ref. 35) for axially loaded specimens of a 33 vol. % $[0^\circ]_4$ SCS-6/Ti-15-3 MMC. They also generated cyclic strain-controlled data for unreinforced specimens of the matrix material and showed that, for $R_\epsilon = 0$ tests, the initially large tensile mean stress quickly relaxed to zero (i.e., $V_\sigma \rightarrow 0$), resulting in hysteresis loops identical to those for $R_\epsilon = -1$ tests. Thus, from the standpoint of the effect of mean stresses in the matrix, it is not expected that the matrix material would initiate and propagate microcracks earlier in the MMC than if fatigued alone.

However, a larger peak tensile stress is experienced by the fibers as they carry a greater portion of the tensile load following relaxation of the matrix tensile mean stresses. Hence, the fibers are forced to operate closer to their peak tensile strain capacity, and the MMC becomes less tolerant of subsequent matrix cracking that will further erode load-bearing areas and transfer more and more tensile stress (and, hence, strain) to the fibers. Thus, cyclic durability resistance of the MMC has been compromised, not by fatigue cracking per se, but by the cyclic flow response characteristics of the matrix and the limited strain capacity of the brittle fibers.

A somewhat similar situation can occur during $R_L = 0$, in-phase, TMF cycling of an MMC in the high-strain fatigue regime. Because of the low flow strength of the matrix material at the maximum TMF temperature, the matrix undergoes inelasticity. In turn, the matrix is driven into compressive stresses (at zero external applied load to the MMC) during the low-temperature excursion of the TMF cycle. The end result of the matrix flow is to cause the fibers to carry a larger and larger share of the peak applied tensile loads. If these loads are high enough, fibers begin to fracture in a run-away sequence that feeds on itself, and the MMC fails as a result of fiber overload before any fatigue cracking can occur in the matrix. An example of such behavior for TMF cycling is found in reference 37 for the SCS-6/Ti-24Al-11Nb MMC system. While the process of transferring more of the tensile stress (and strain) to the fiber will have a detrimental effect on cyclic lifetime, this mechanism alone is not expected to be responsible for the large discrepancy between the two fatigue curves shown in figure 7.

Explanation for an additional portion of the discrepancy can be found in examination of the differences in the control

modes used in the two test series. The MMC fatigue tests used load control and only tensile loads were imposed ($R_L = 0$), whereas the matrix fatigue tests were conducted under completely reversed strain control ($R_\epsilon = -1$). Had the MMC fatigue tests been conducted with the same range of load, and hence same range of strain with $R_L = -1$ (to keep the results of fig. 7 more comparable), the peak tensile stress (or strain) experienced by the fibers would have been 50 percent lower. Consequently, much more extensive matrix fatigue cracks and considerable fiber cracking had to occur before the remaining load-carrying fibers would be pushed to their peak tensile strain limit. Using this line of reasoning, the MMC specimens could have endured more loading cycles, thus resulting in lives closer to those exhibited by the unreinforced matrix material.

Additional qualitative explanation for the discrepancy is found in the microcrack propagation portion of cyclic life which can be reduced in the MMC as a result of two important factors. First, in the MMC, cracks can initiate internally and subsequently link, thus reducing cyclic life. Second, internal oxidation at 427 °C can occur along the interfaces and any interior cracks. A loss of a factor of 4 in microcrack propagation life by these means is certainly within the realm of possibility. Furthermore, the microcrack initiation portion of specimen fatigue life has been observed via fractography (ref. 35) to be essentially bypassed in this MMC system. This is likely due to the nature of the interfacial material and its relatively poor bonding to both fiber and matrix. At a cyclic strain range giving a life of 10^7 cycles to failure for the unreinforced matrix material, the microcrack initiation portion is expected to be 90 percent of the total macrocrack initiation life in accordance with equation (6c). Thus an additional factor of 10 loss in life can be attributed to the loss of microcrack initiation life. The two life losses are multiplicative (i.e., $4 \times 10 = 40$), which is in general agreement with the losses shown in figure 7. For the time being, it is not possible to quantify the degree of loss with any confidence in accuracy. A series of strain-controlled, $R_\epsilon = -1$, low-cycle fatigue tests of MMC coupons is planned. The results are expected to provide a better understanding of the causes of the large observed life losses in this MMC material for $R_L = 0$.

Silicon Carbide/Titanium Aluminide IMC

Isothermal, load-controlled, low-cycle fatigue results for coupons of SCS-6/Ti-24Al-11Nb have been reported by Brindley, MacKay, and Bartolotta (ref. 36), and by Russ et al. (ref. 37). Fiber volume percentages range from 27 to 33. In both cases, the only strain data reported was the maximum tensile cyclic strain imposed on the MMC specimens. Both sets of investigators have since supplied us with the average cyclic strain ranges for each fatigue test analyzed herein. Isothermal tensile and fatigue data on Ti-24Al-11Nb unreinforced matrix material have been reported by DeLuca et al. (ref. 39). The matrix fatigue data are from completely

reversed, strain-cycling ($R_\epsilon = -1$) axial experiments with a frequency of 0.17 Hz, whereas the MMC data are for unidirectional coupons subjected to $R_L = 0$ (ref. 36) or 0.1 (ref. 37) with frequencies of about 0.2 to 0.3 Hz (ref. 36) and 3.0 Hz (ref. 37). The basic mechanical loading conditions were similar to those for the SCS-6/Ti-15-3 system analyzed in the preceding subsection.

Figures 8(a) and (b) show comparisons between the fatigue resistances of the unreinforced matrix material and MMC coupons at 427 and 650 °C, respectively. There is similarity between the sets of curves in figures 8(a) and (b) and those of figure 7. The MMC's resistance to cyclic strain is below that of the unreinforced matrix by factors ranging from about 1.7 to 2.0. In terms of cyclic life, the MMC resistance is between 10 and 100 times lower than the unreinforced matrix material for the same total mechanical strain range. The arguments that were applied to the interpretation of the SCS-6/Ti-15-3 titanium MMC system results are just as applicable to the SCS-6/Ti-24Al-11Nb titanium aluminide MMC system. We are unaware of any current plans to test thick samples of the

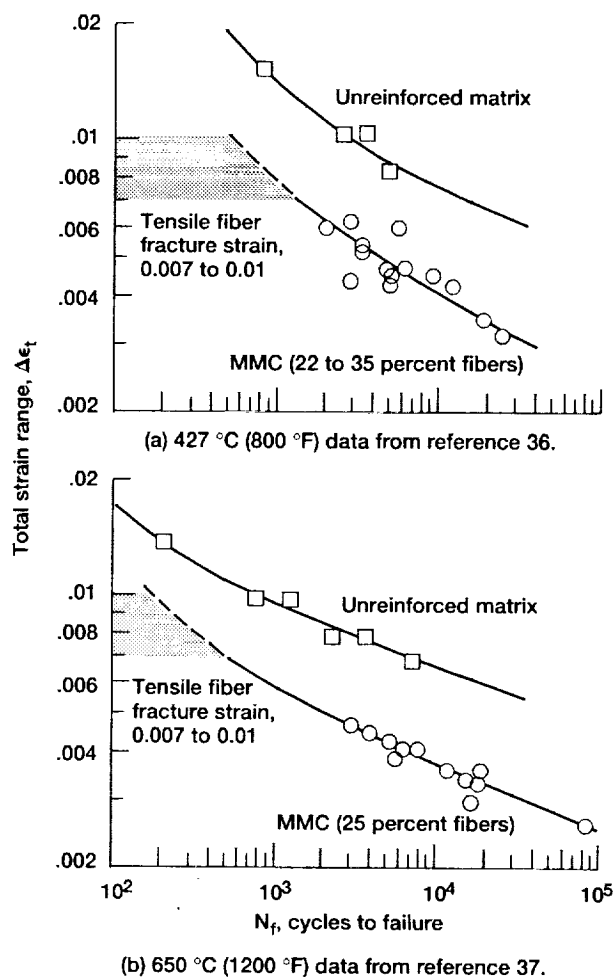

Figure 8.—Comparison of isothermal fatigue resistance of SCS-6/Ti-24Al-11Nb MMC with Ti-24Al-11Nb unreinforced matrix material (ref. 39).

titanium aluminide MMC system under conditions of completely reversed, strain-control fatigue. Such test results would be invaluable in providing an assessment of the currently proposed framework for MMC fatigue life prediction.

Concluding Remarks

A framework has been proposed for a life prediction system applicable to cyclic thermal and mechanical fatigue and creep-fatigue loading of unidirectional, continuous-fiber, metal matrix composites. A local micromechanics stress-strain approach was adopted to impart the maximum degree of generality. The classically fatigue-prone metal matrix was selected as the vehicle for tracking the cycle-dependent changes (mean stress relaxation, hardening, softening, microcrack initiation, and microcrack propagation). The presence of fibers and interfacial layers is taken into account by the influence they exert on the stress-strain and failure response behavior of the matrix material. Similarly, the influence on the fiber of the presence of the interfacial and matrix materials is given consideration. Considerably more analytical and experimental research is needed to expand on the framework and bring the approach to its full potential. Examples of isothermal fatigue data for MMC's taken from the literature illustrate important aspects of the modeling framework.

Acknowledgment

The assistance of Dr. S.M. Russ, United States Air Force, Wright Laboratories, Dayton, Ohio in sharing valuable fatigue data for SCS-6/Ti-24Al-11Nb intermetallic matrix composites is greatly appreciated.

National Aeronautics and Space Administration
Lewis Research Center
Cleveland, Ohio, January 11, 1993

References

- Caruso, J.J.; and Chamis, C.C.: Superelement Methods Applications to Micromechanics of High Temperature Metal Matrix Composites. Structures, Structural Dynamics, and Materials Conference, 29th, Pt. 3, AIAA, Washington, DC, 1988, pp.1388-1400. (Also, AIAA Paper 88-2390, 1988.)
- Lerch, B.A.; Melis, M.E.; and Tong, M.: Experimental and Analytical Analysis of the Stress-Strain Behavior in a [90/0]₂, SiC/Ti-15-3 Laminate. NASA TM-104470, 1991.
- Chamis, C.C.; Caruso, J.J.; and Lee, H.-J.: METCAN Verification Status. NASA TM-103119, 1990.
- Halford, G.R., et al.: LCF Life Prediction for MMC's. HITEMP Review 1989, NASA CP-10039, 1989, pp. 64-1 to 64-9.
- Halford, G.R.: Low-Cycle Thermal Fatigue. Thermal Stresses II, R.B. Hetnarski, ed., Elsevier Science Publishers B.V., New York, 1987, pp. 329-428. (Also, NASA TM-87225, 1986.)
- Halford, G.R., et al.: Bithermal Fatigue: A Link Between Isothermal and Thermomechanical Fatigue. Low Cycle Fatigue, ASTM STP-942, H.D. Solomon et al., eds., American Society for Testing and Materials, Philadelphia, PA, 1988, pp.625-637.
- Saltsman, J.F.; and Halford, G.R.: Life Prediction of Thermo-mechanical Fatigue Using The Total Strain Version of Strainrange Partitioning (SRP)—A Proposal. NASA TP-2779, 1988.
- Saltsman, J.F.; and Halford, G.R.: An Update on the Total Strain Version of SRP. Low Cycle Fatigue, ASTM STP-942, H.D.Solomon et al., eds., American Society for Testing and Materials, Philadelphia, PA, 1988, pp. 329-341.
- Halford, G.R., et al.: Thermomechanical and Bithermal Fatigue Behavior of Cast B1900 + Hf and Wrought Haynes 188. Advances in Fatigue Lifetime Predictive Techniques, ASTM STP-1122, M.R. Mitchell and R.W. Landgraf, eds., American Society for Testing and Materials, Philadelphia, PA, 1991, pp. 120-142. (Also, NASA TM-4225, 1991.)
- Halford, G.R., et al.: Application of a New Thermal Fatigue Life Prediction Model to Two High-Temperature Aerospace Alloys. Advances in Fatigue Lifetime Predictive Techniques, ASTM STP-1122, M.R. Mitchell and R.W. Landgraf, eds., American Society for Testing and Materials, Philadelphia, PA, 1991, pp. 107-119.
- Bodner, S.R.; and Partom, Y.: Constitutive Equations for Elastic-Viscoplastic Strain-Hardening Materials. J. Appl. Mech., vol. 42, no. 2, June 1975, pp. 385-389.
- Walker, K.P.: Research and Development Program for Nonlinear Structural Modeling With Advanced Time-Temperature Dependent Constitutive Relations. NASA CR-165533, 1981.
- Robinson, D.A.; and Swindeman, R.W.: Unified Creep-Plasticity Constitutive Equations for 2-1/4Cr-1Mo Steel at Elevated Temperature. ORNL Report TM-8444, Oak Ridge National Laboratories, Oak Ridge, TN, 1982.
- Freed, A.: Thermoviscoplastic Model With Application to Copper. NASA TP-2845, 1988.
- Manson, S.S.: Fatigue: A Complex Subject—Some Simple Approximations. Exp. Mech., vol. 5, no. 7, 1965, pp. 193-226.
- Garmong, G.: Elastic-Plastic Analysis of Deformation Induced by Thermal Stress in Eutectic Composites: I. Theory. Metall. Trans. A, vol. 5, 1974, pp. 2183-2190.
- Halford, G.R.; and Nachtigall, A.J.: The Strainrange Partitioning Behavior of an Advanced Gas Turbine Disk Alloy, AF2-1DA. J. Aircraft, vol. 17, no. 8, 1980, pp. 598-604.
- Morrow, J.: Fatigue Properties in Metals. Fatigue Design Handbook, Sect. 3.2, J.A. Graham, ed., Society of Automotive Engineers, Inc., Warrendale, PA, 1968, pp. 21-29.
- Manson, S.S.; and Halford, G.R.: Treatment of Multiaxial Creep-Fatigue by Strainrange Partitioning. 1976 ASME-MPS Symposium on Creep-Fatigue Interaction: Presented at the Winter Annual Meeting, R.M. Curran, ed., American Society of Mechanical Engineers and the Metals Properties Council, New York, 1976, pp. 299-322.
- Manson, S.S.; and Halford, G.R.: Discussion of Paper by J.J. Blass and S.Y. Zamrik in Symposium on Creep-Fatigue Interaction, ASME, 1976, pp. 129-159. J. Eng. Mater. Technol., vol. 99, no. 3, July 1977, pp. 283-286.
- Hashin, Z.; and Rotem, A.: A Fatigue Failure Criterion for Fiber Reinforced Materials. J. Compos. Mater., vol. 7, Oct. 1973, pp.448-464.
- Bigelow, C.A.: The Effect of Uneven Fiber Spacing on Thermal Residual Stresses in a Unidirectional SCS-6Ti-15-3 Laminate. NASA TM-104225, 1992.
- Jansson, S.; and Leckie, F.A.: Reduction of Thermal Stresses in Continuous Fiber Reinforced Metal Matrix Composites with Interface Layers. NASA CR-185302, 1990.

24. Arnold, S.M.; Arya, V.K.; and Melis, M.E.: Elastic/Plastic Analyses of Advanced Composites Investigating the Use of the Compliant Layer Concept in Reducing Residual Stress Resulting from Processing. NASA TM-103204, 1990.
25. Chen, E.J.H.; and Young, J.C.: The Microdebonding Testing System – A Method of Quantifying Adhesion in Real Composites. *Compos. Sci. Technol.*, vol. 42, no. 1-3, 1991, pp. 189-206.
26. Ghosn, L.J.; Kantzos, P.; and Telesman, J.: Modeling of Crack Bridging in a Unidirectional Metal Matrix Composite. NASA TM-104355, 1991.
27. Lerch, B.A.; Gabb, T.P.; and MacKay, R.A.: Heat Treatment Study of the SiC/Ti-15-3 Composite System. NASA TP-2970, 1990.
28. Nissley, D.M.; Meyer, T.G.; and Walker, K.P.: Life Prediction and Constitutive Models for Engine Hot Section Anisotropic Materials Program. (PWA-5968-102, Pratt and Whitney Aircraft Group, NASA Contract NAS3-23939), NASA CR-189223, 1992.
29. Neu, R.W.; and Sehitoglu, H.: Thermomechanical Fatigue, Oxidation, and Creep: Part I. Damage Mechanisms. *Metall. Trans. A*, Vol. 20A, 1989, pp. 1755-1767.
30. Neu, R.W.; and Sehitoglu, H.: Thermomechanical Fatigue, Oxidation, and Creep: Part II. Life Prediction. *Metall. Trans. A*, vol. 20A, 1989, pp. 1769-1783.
31. Miller, M.P.; McDowell, D.L.; and Oehmkc, R.L.T.: A Life Prediction Model for Thermomechanical Fatigue Based on Microcrack Propagation. Submitted for publication in the Proceedings of the Symposium on Thermo-Mechanical Fatigue Behavior of Materials, American Society for Testing and Materials, San Diego, CA, Oct. 1991.
32. Johnson, W.S.; Lubowinski, S.J.; and Highsmith, A.L.: Mechanical Characterization of Unnotched SCS₆/Ti-15-3 Metal Matrix Composites at Room Temperature. Thermal and Mechanical Behavior of Metal Matrix and Ceramic Matrix Composites, ASTM STP-1080, J.M. Kennedy, H.H. Moeller, and W.S. Johnson, eds., American Society for Testing and Materials, Philadelphia, PA, 1990, pp. 193-218.
33. Johnson, W.S.: Modeling Stiffness Loss in Boron/Aluminum Laminates Below the Fatigue Limit. Long-Term Behavior of Composites, Proceedings of the Symposium, ASTM STP-813, T.K. O'Brien, ed., American Society for Testing and Materials, Philadelphia, PA, 1983, pp. 160-176.
34. Verrilli, M.J.; and Gabb, T.P.: High Temperature Tension-Compression Fatigue Behavior of a Tungsten Copper Composite. NASA TM-104370, 1990.
35. Gayda, J.; Gabb, T.P.; and Freed, A.D.: The Isothermal Fatigue Behavior of a Unidirectional SiC/Ti Composite and the Ti Alloy Matrix. Fundamental Relationships Between Microstructure and Mechanical Properties of Metal-Matrix Composites, Proceedings of the Symposium TMS Fall Meeting, P.K. Liaw and M.N. Gungor, eds., The Minerals, Metals & Materials Society, Warrendale, PA, 1990, pp.497-514.
36. Brindley, P.K.; MacKay, R.A.; and Bartolotta, P.A.: Thermal and Mechanical Fatigue of a SiC/Ti-24Al-11Nb Composite. Titanium Aluminide Composites, P.R. Smith, S.J. Balsone, and T. Nicholas, eds., WL-TR-91-4020, Wright Patterson Air Force Base, OH, 1991, pp. 484-496. (Also, NASA TM-103279, 1990.)
37. Russ, S.M., et al.: Thermomechanical Fatigue of SCS-6/Ti-24Al-11Nb Metal Matrix Composite. Failure Mechanisms in High Temperature Composite Materials, AD-Vol. 22/AMD-Vol. 122, ASME, 1991, pp. 37-43.
38. Conway, J.B.; Stentz, R.H.; and Berling, J.T.: High Temperature, Low-Cycle Fatigue of Copper-Base Alloys in Argon; Part I – Preliminary Results for 12 Alloys at 1000 °F (538 °C). NASA CR-121259, 1973.
39. DeLuca, D.P., et al.: Fatigue and Fracture of Titanium Aluminides. Report WRDC TR-89-4136, Pratt and Whitney Aircraft, West Palm Beach, FL, 1990.

REPORT DOCUMENTATION PAGE			Form Approved OMB No. 0704-0188	
Public reporting burden for this collection of information is estimated to average 1 hour per response, including the time for reviewing instructions, searching existing data sources, gathering and maintaining the data needed, and completing and reviewing the collection of information. Send comments regarding this burden estimate or any other aspect of this collection of information, including suggestions for reducing this burden, to Washington Headquarters Services, Directorate for Information Operations and Reports, 1215 Jefferson Davis Highway, Suite 1204, Arlington, VA 22202-4302, and to the Office of Management and Budget, Paperwork Reduction Project (0704-0188), Washington, DC 20503.				
1. AGENCY USE ONLY (Leave blank)	2. REPORT DATE July 1993	3. REPORT TYPE AND DATES COVERED Technical Paper		
4. TITLE AND SUBTITLE Proposed Framework for Thermomechanical Life Modeling of Metal Matrix Composites			5. FUNDING NUMBERS WU-505-63-52	
6. AUTHOR(S) Gary R. Halford, Bradley A. Lerch, and James F. Saltsman			8. PERFORMING ORGANIZATION REPORT NUMBER E-7483	
7. PERFORMING ORGANIZATION NAME(S) AND ADDRESS(ES) National Aeronautics and Space Administration Lewis Research Center Cleveland, Ohio 44135-3191			10. SPONSORING/MONITORING AGENCY REPORT NUMBER NASA TP-3320	
9. SPONSORING/MONITORING AGENCY NAME(S) AND ADDRESS(ES) National Aeronautics and Space Administration Washington, D.C. 20546-0001			11. SUPPLEMENTARY NOTES Responsible person, Gary R. Halford, (216) 433-3265.	
12a. DISTRIBUTION/AVAILABILITY STATEMENT Unclassified - Unlimited Subject Categories 39 and 24			12b. DISTRIBUTION CODE	
13. ABSTRACT (Maximum 200 words) The framework of a mechanics of materials model is proposed for thermomechanical fatigue (TMF) life prediction of unidirectional, continuous-fiber metal matrix composites (MMC's). Axially loaded MMC test samples are analyzed as structural components whose fatigue lives are governed by local stress-strain conditions resulting from combined interactions of the matrix, interfacial layer, and fiber constituents. The metallic matrix is identified as the vehicle for tracking fatigue crack initiation and propagation. The proposed framework has three major elements. First, TMF flow and failure characteristics of in situ matrix material are approximated from tests of unreinforced matrix material, and matrix TMF life prediction equations are numerically calibrated. The macrocrack initiation fatigue life of the matrix material is divided into microcrack initiation and microcrack propagation phases. Second, the influencing factors created by the presence of fibers and interfaces are analyzed, characterized, and documented in equation form. Some of the influences act on the microcrack initiation portion of the matrix fatigue life, others on the microcrack propagation life, while some affect both. Influencing factors include coefficient of thermal expansion mismatch strains, residual (mean) stresses, multiaxial stress states, off-axis fibers, internal stress concentrations, multiple initiation sites, nonuniform fiber spacing, fiber debonding, interfacial layers and cracking, fractured fibers, fiber deflections of crack fronts, fiber bridging of matrix cracks, and internal oxidation along internal interfaces. Equations exist for some, but not all, of the currently identified influencing factors. The third element is the inclusion of overriding influences such as maximum tensile strain limits of brittle fibers that could cause local fractures and ensuing catastrophic failure of surrounding matrix material. Some experimental data exist for assessing the plausibility of the proposed framework.				
14. SUBJECT TERMS Metal matrix composites; Fatigue (metal); Thermal fatigue; Thermomechanical fatigue; Bithermal fatigue; Low-cycle fatigue; High-temperature fatigue; Creep-fatigue; Life prediction; Strainrange partitioning; Crack initiation			15. NUMBER OF PAGES 16	
			16. PRICE CODE A03	
17. SECURITY CLASSIFICATION OF REPORT Unclassified	18. SECURITY CLASSIFICATION OF THIS PAGE Unclassified	19. SECURITY CLASSIFICATION OF ABSTRACT Unclassified	20. LIMITATION OF ABSTRACT	