

**THE ACTS PROPAGATION TERMINAL
DELIVERY AND SUPPORT**

Warren Stutzman

Virginia Polytechnic Institute & State University
Bradley Department of Electrical Engineering
Satellite Communications Group
Blacksburg, Virginia 24061-0111

**ACTS MINI-WORKSHOP
PASADENA, CA**

June 14, 1993



VIRGINIA TECH

Satellite
Communications
Group

OUTLINE

- APT Program Overview
- Terminal Overview
- Physical units
- Test results
- Status of terminals and schedule
- Shipping cartons
- Site Support

ACTS PROPAGATION TERMINAL (APT) DEVELOPMENT PROGRAM OVERVIEW

OLYMPUS Measurement Campaign

12, 20, 30 GHz beacons

Tested shared beacon receiver/total power radiometer design

Determined that 1 Hz sample rate is sufficient

Developed data collection software

Goals for APT

Developed by user community

APT Prototype (1991-92)

PDR: May 30, 1991

CDR: July 7, 1992

System tests with Olympus and ACTS: Summer 1992

APT Production (March 1992 - June 1993)

Produce 7 terminals for experimenters

Maintain prototype

ACTSVIEW software

Preprocessing software

Experiment Support (July 1993 -)

APT CHARACTERISTICS

ACTS Spacecraft Beacons

Frequency		
Primary	20.185 GHz (V)	27.505 GHz (V)
Backup	20.195 GHz (H)	27.505 GHz (V)

Antenna

1.22 m offset HP: 0.85° @ 20.2 GHz 0.61° @ 27.5 GHz

Beacon Receivers

RF: Direct downconversion to 70 MHz

IF: 5 MHz intermediate, 455 kHz output

Sampling: 606 kHz (303 I, Q) at 455 kHz

DRX: Acquisition

Bandwidth: 180 kHz

Algorithm: 6 - 32k FFTs

Time to acquire: 3 s in fades up to 25 dB

Tracking

Bandwidth: 10 kHz

Algorithm: FFT and filtering to determine frequency and power

Lock: 31 dB fade

Radiometers

Input: 70 MHz from RF

Type: Total power

Detection bandwidth: 50 MHz

APT FUNCTIONAL SUBSYSTEMS

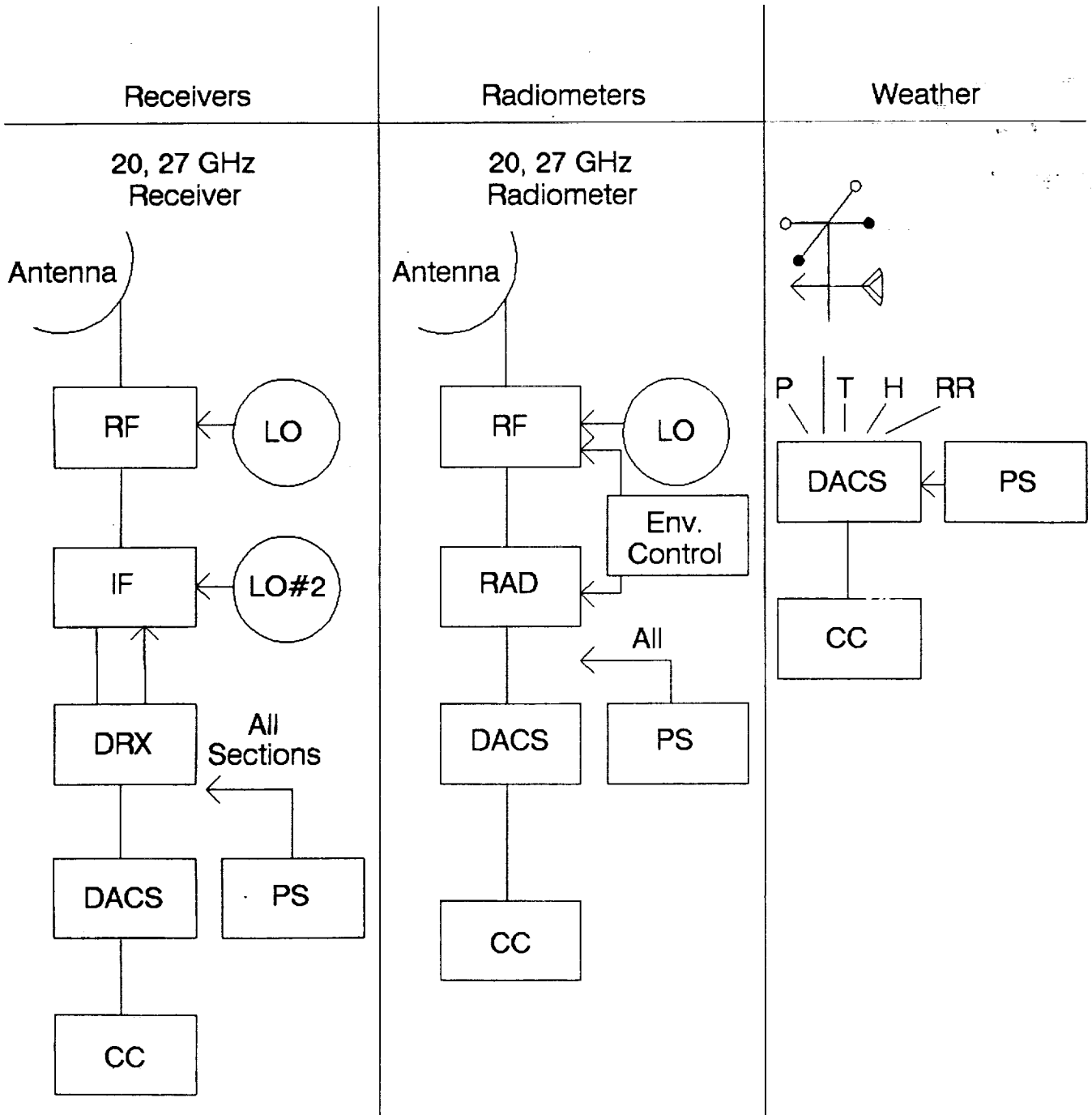

ACTS Propagation Terminal Physical Diagram

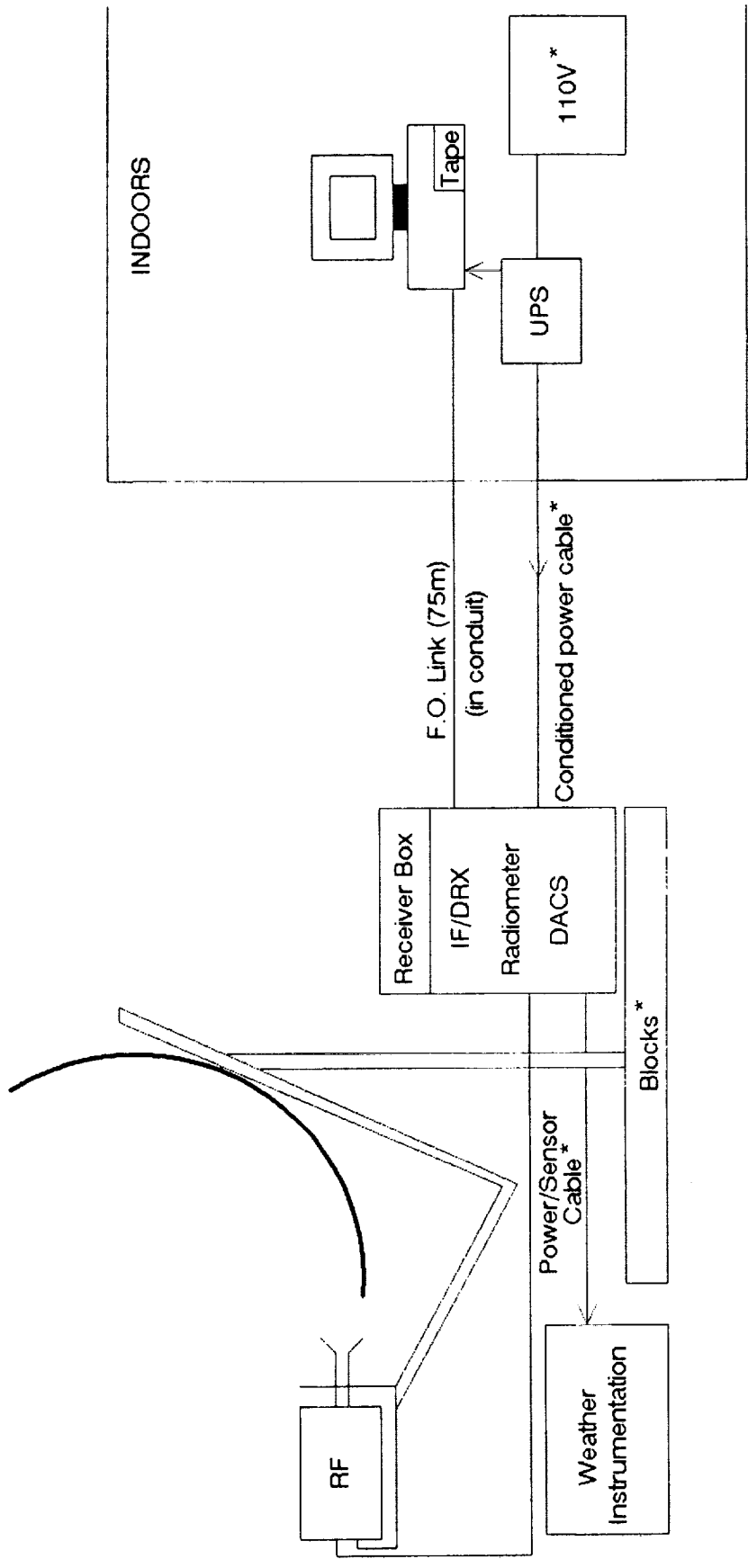

* User supplied

physical.drw
06/09/92

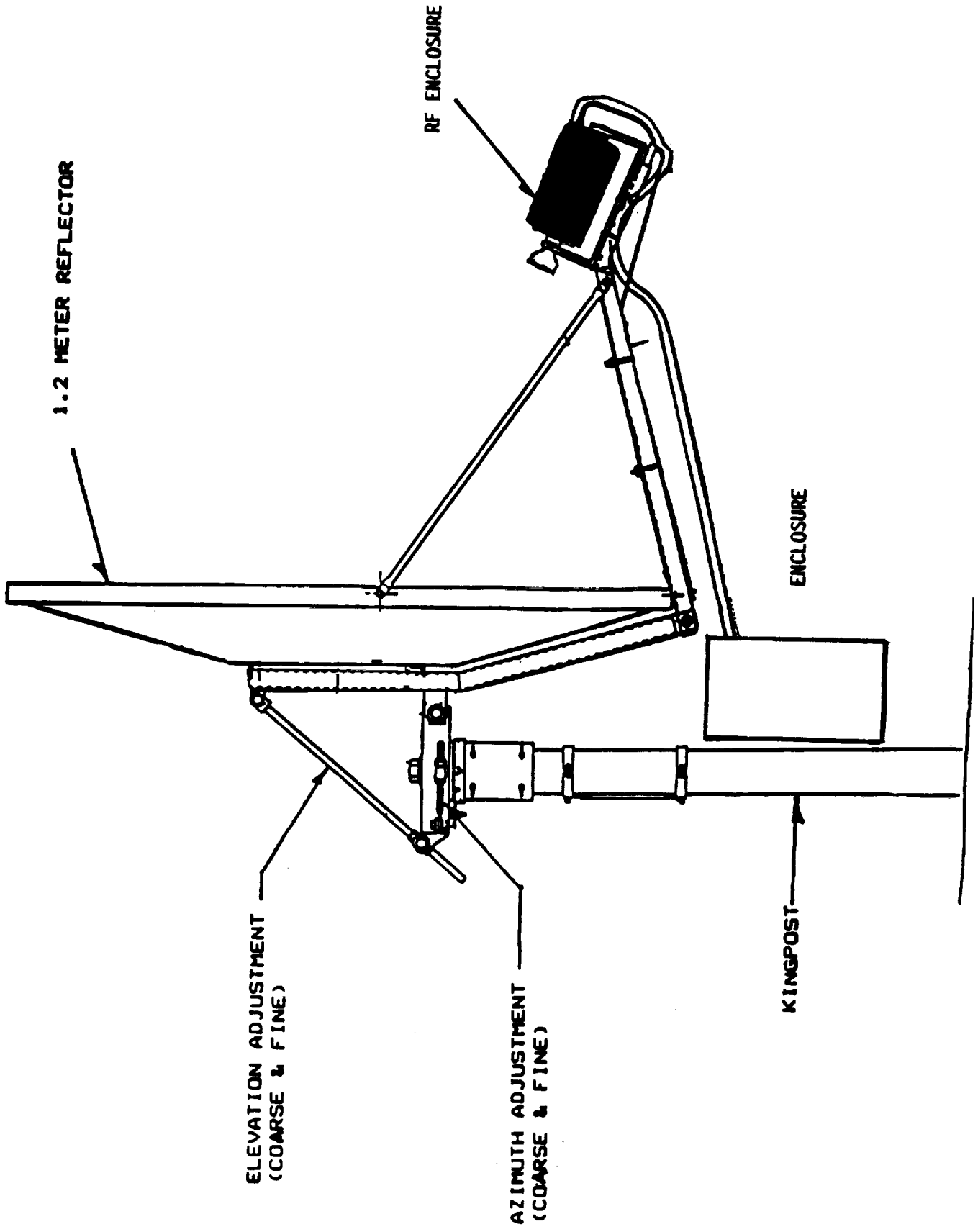

ACTS Receiver Enclosure Layout

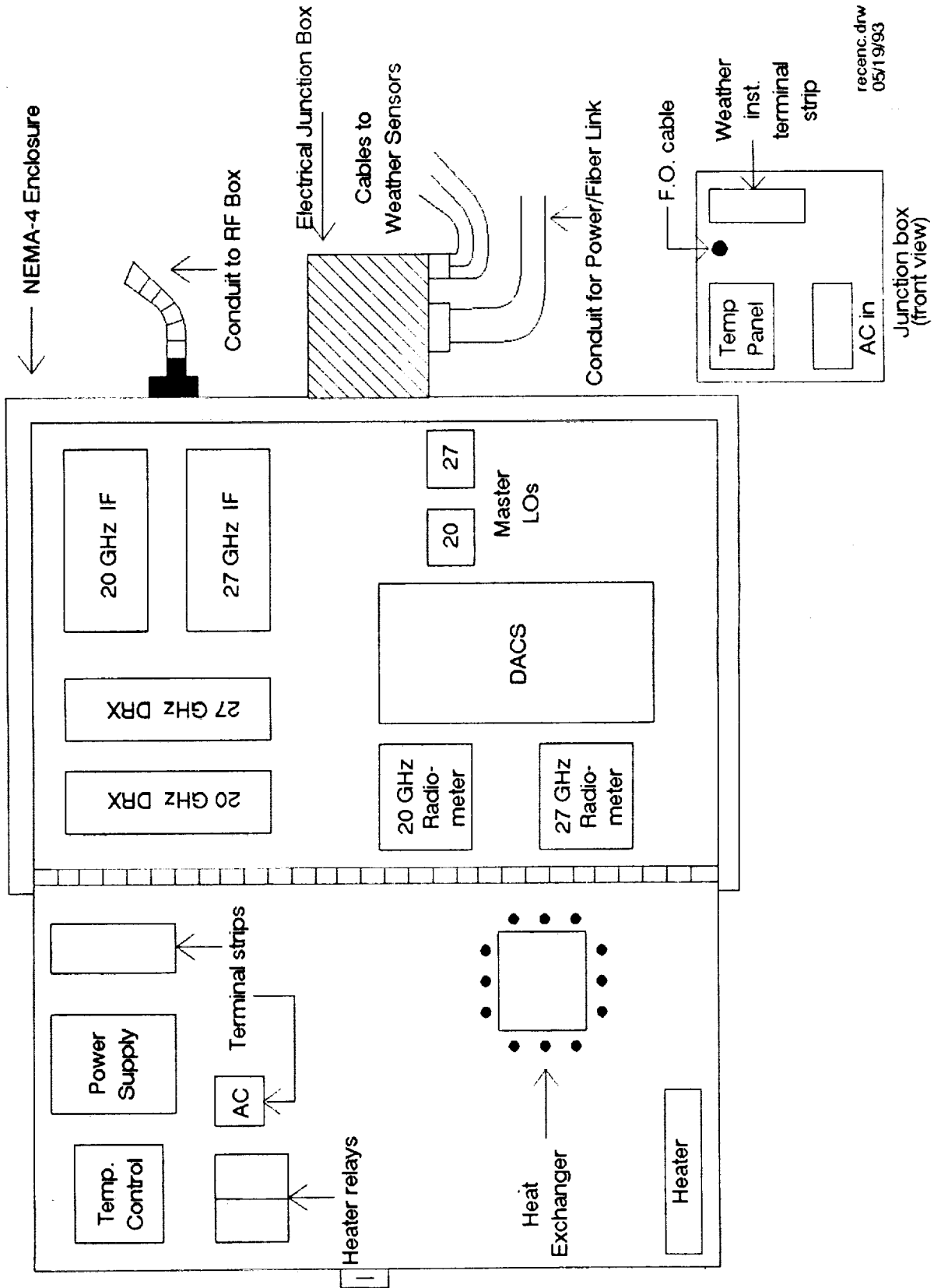

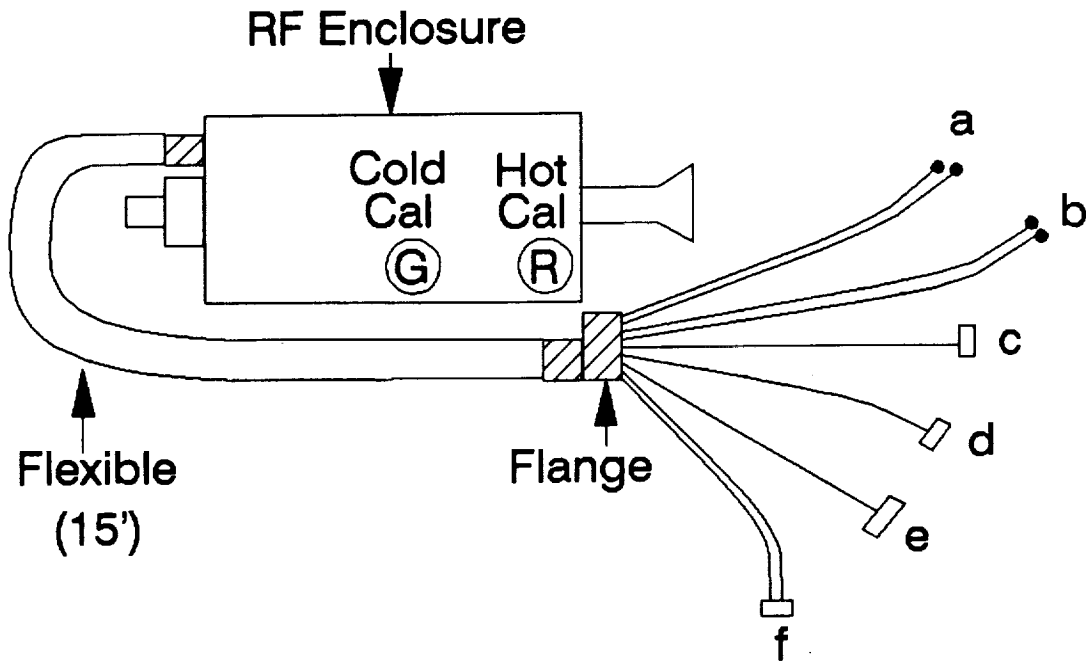

- a) LO drive (20, 27) RG58 w/SMA-male.
- b) 70 MHz IF (20, 27) Microflex 150 w/SMA-male.
- c) RF power cable, 3 conductor twisted w/4 pin molex.
- d) RF control cable w/DB25 male connector.
- e) RF control cable w/DB9 male connector.
- f) RF temperature control cable assy (two cables) w/DB-15 profile hybrid connector.

conduit.drw
06/01/93

Figure 3.1-2. Conduit/Cable assembly between RF and Receiver Enclosures.

ACTS PROPAGATION TERMINAL

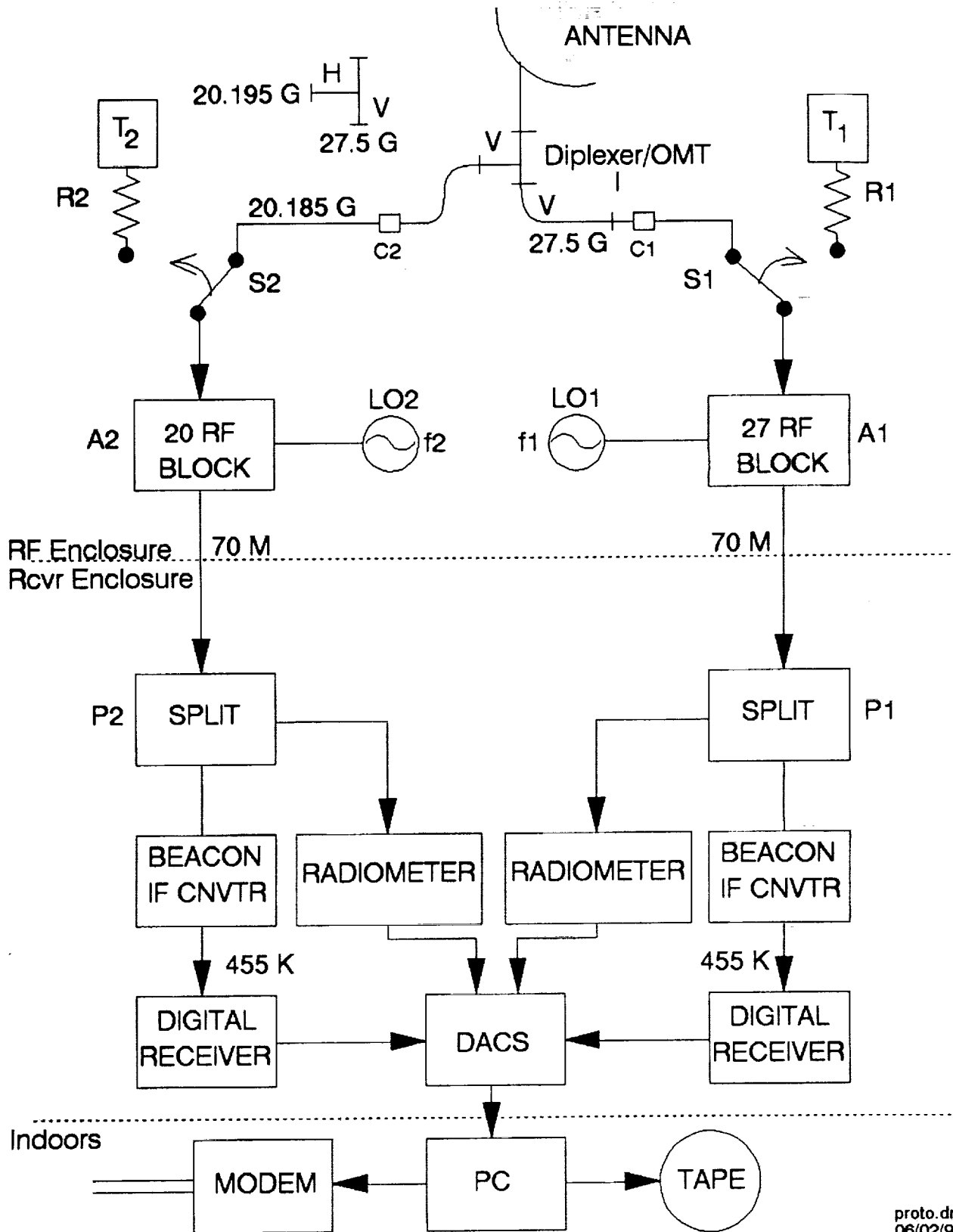

proto.drw
06/02/92

TEST RESULTS

- IF/Digital Receiver (Prototype)
 - Signal injection - linear response
 - Olympus 20 GHz beacon during a rain storm -
Reproduced Olympus analog receiver exactly
- Full Prototype system
 - ACTS spacecraft in NJ - acquired and measured spectra
- Beacon tests - Production
 - RF signal injection
 - Stable with time tests
- Radiometer tests - Production
 - Hot/Cold calibrations
 - Stable with time tests
 - Rain Measurements with system outside

ACTS

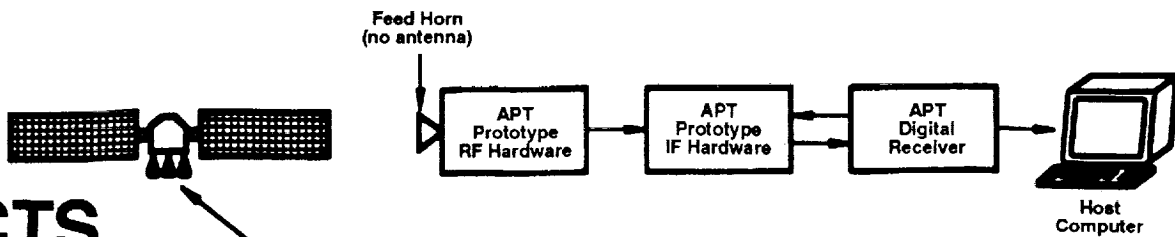

Microwave absorber was placed over the beacon transmitter payload to reduce the beacon signal strengths to levels compatible with the APT system

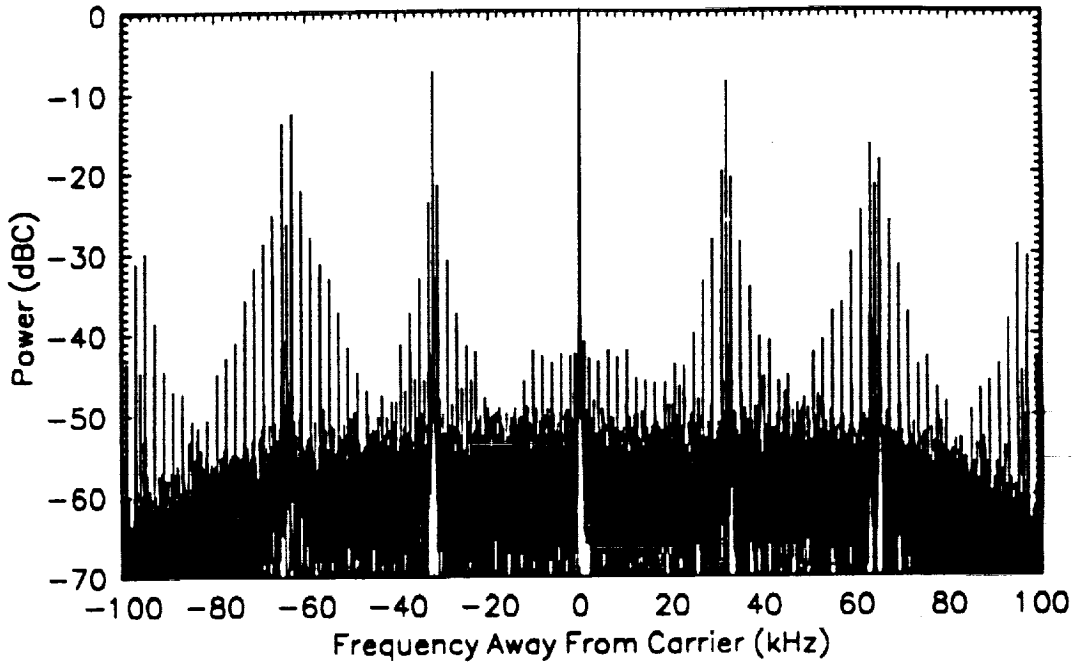

32768-point spectrum of the ACTS 20 GHz beacon in *Digital PCM Telemetry Mode*.

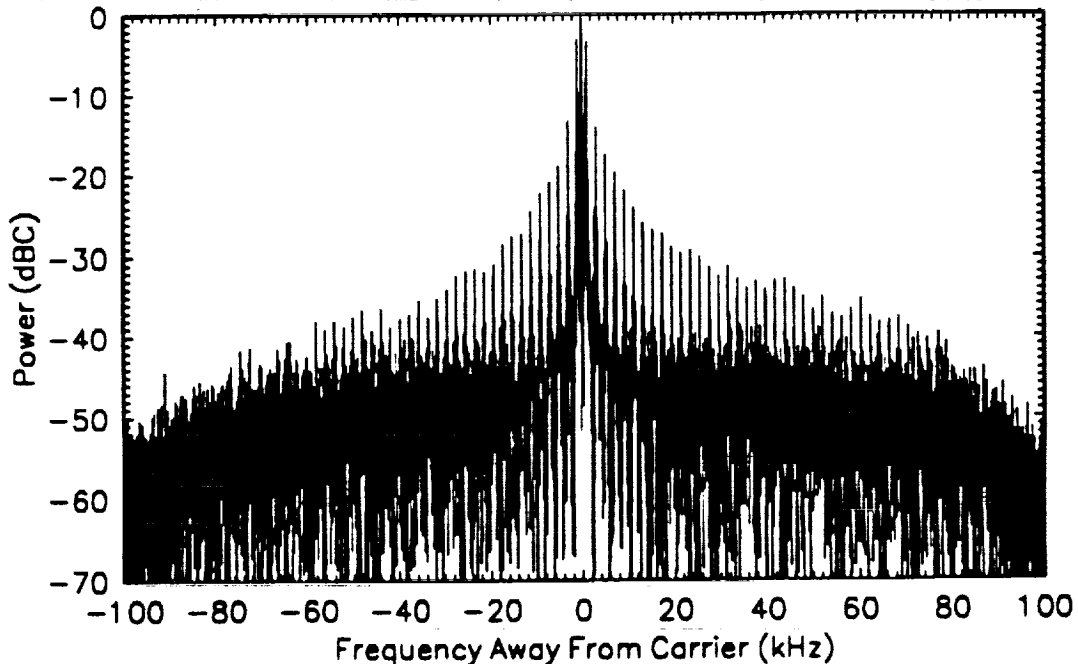

32768-point spectrum of the ACTS 20 GHz beacon in *PCM Direct Mode*.

ACTS Digital Receiver Power Measurement

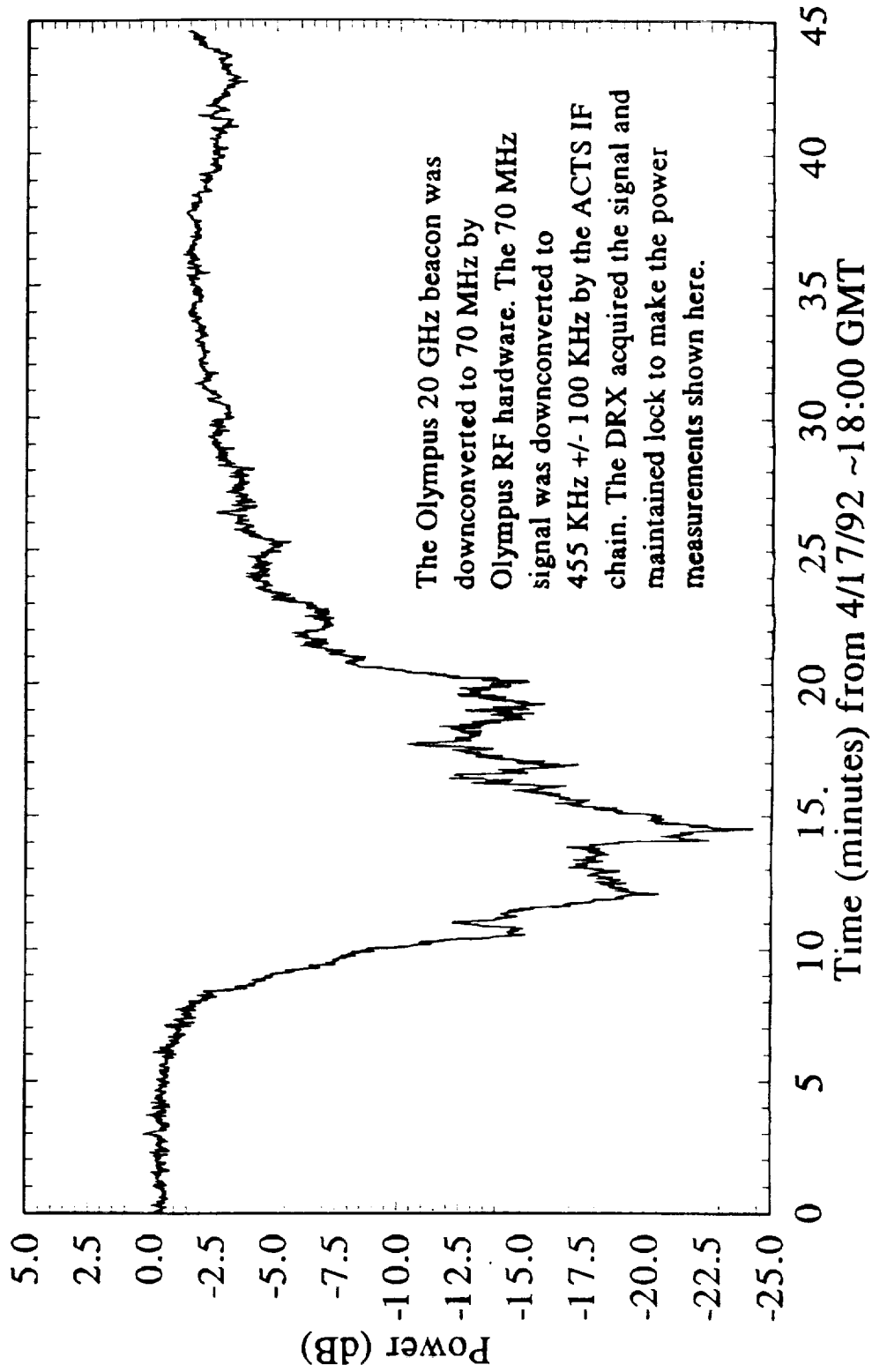

OLYMPUS Analog Receiver Power Measurement

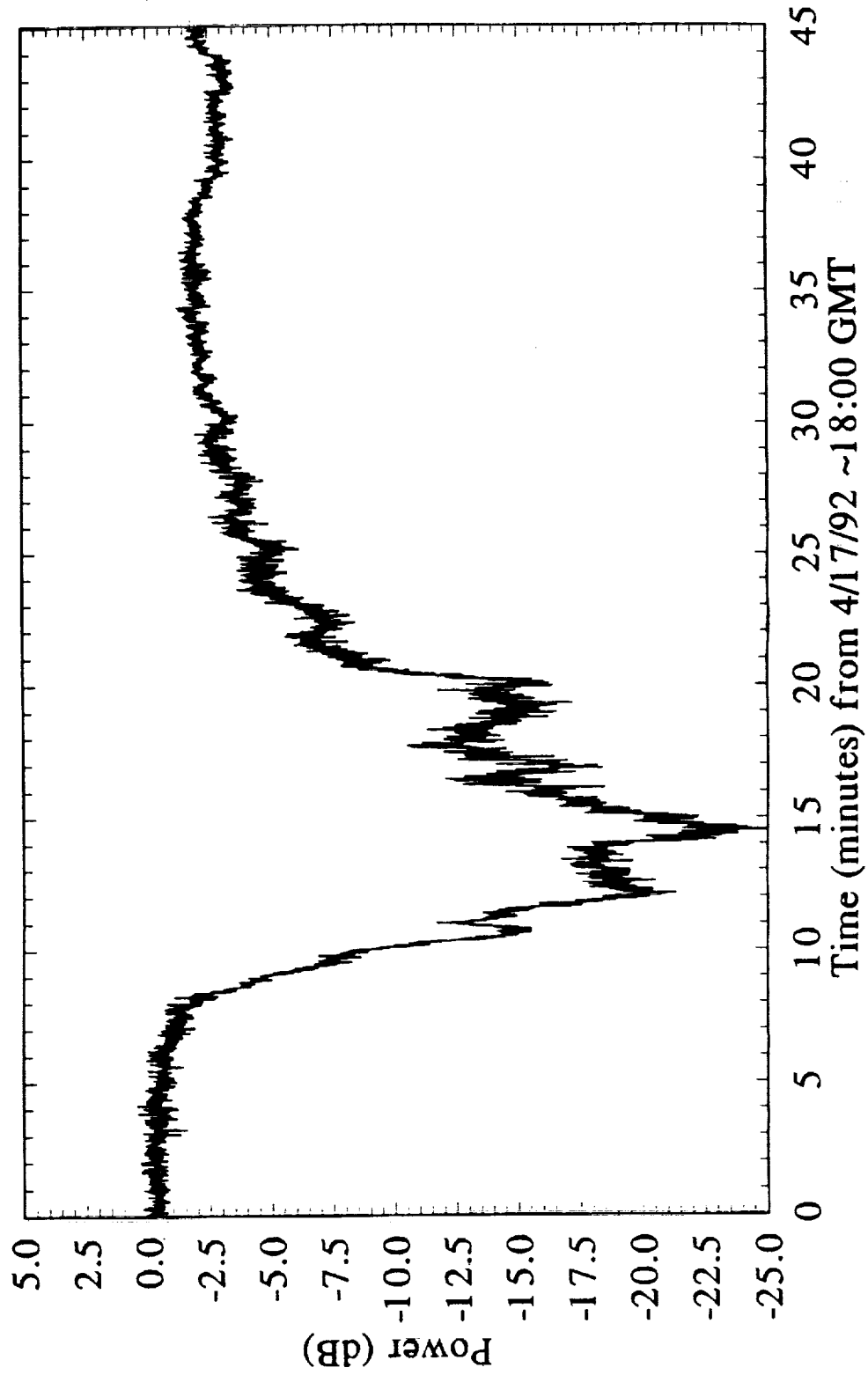

Radiometer Operation during a Thunderstorm

FILE DISPLAY ZOOM PAUSE

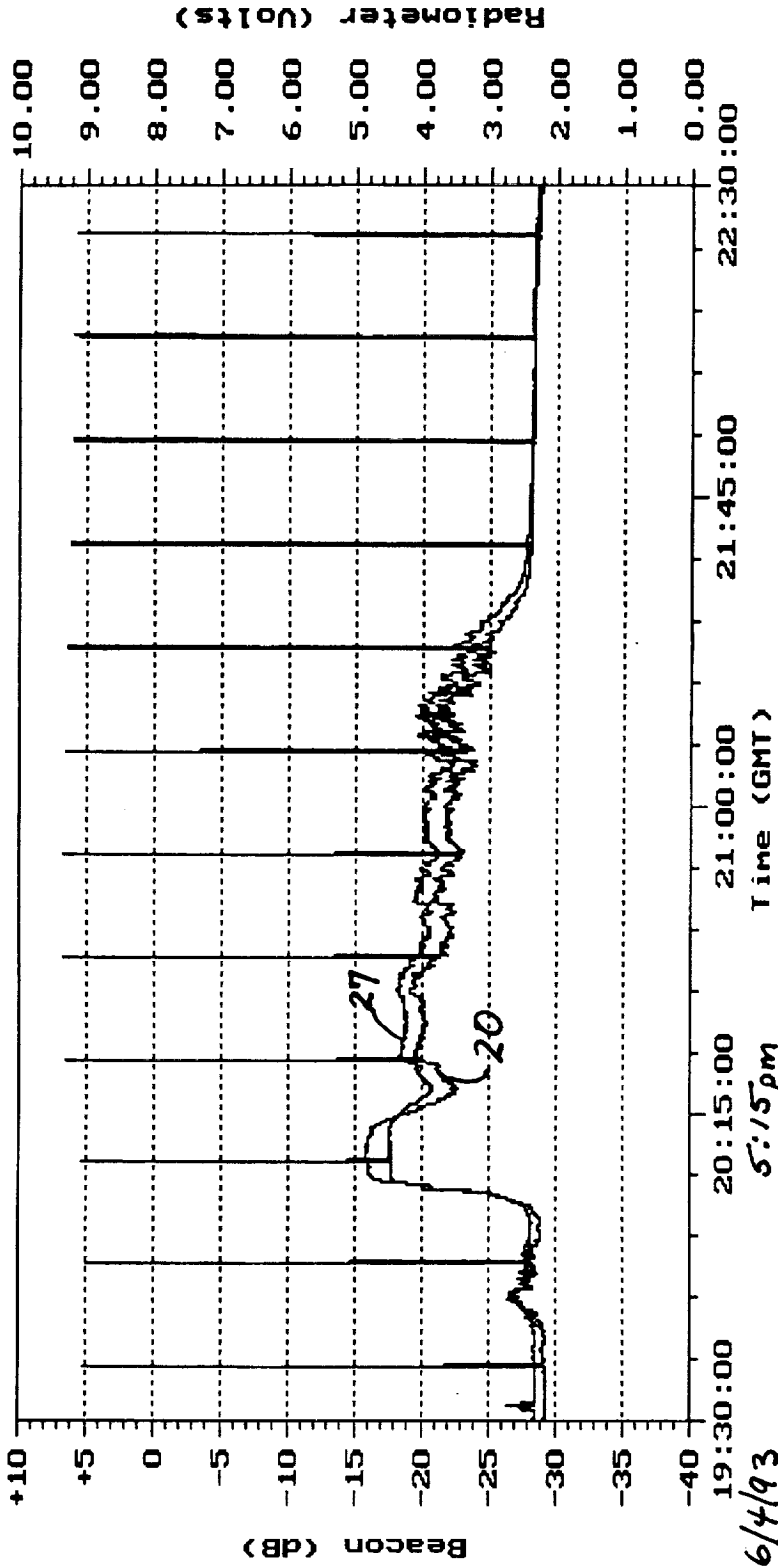

Source: 9306040K.RVD

- 20 G Beacon (U)
- 27 G Beacon (U)
- 20 G Radiometer
- 27 G Radiometer

System Status - XXXXXX

RH: XXX % CRG: XXXXX mm/hr
 BP: XXXX mb ORG: XXXXX2mm/hr
 MS: XXXX m/s TRG: XXXXX mm/hr
 WD: XXX ° OT: XXXXXX °C
 Time: 14:07:44 Date: 06/07/93

Ready for
Spectrum

APT SHIPPING CARTONS

- Units shipped from Blacksburg, Virginia

<u>Box No.</u>	<u>Description</u>
1	Receiver Enclosure
2	RF Enclosure
3	Computer CPU
4	Computer Monitor
5	Miscellaneous

- Units shipped directly from manufacturers
 - Antenna pedestal
 - Antenna
 - Wind gauge
 - Capacitive rain gauge
 - Uninterruptable power supply

ACTS Propagation Terminal Production Schedule

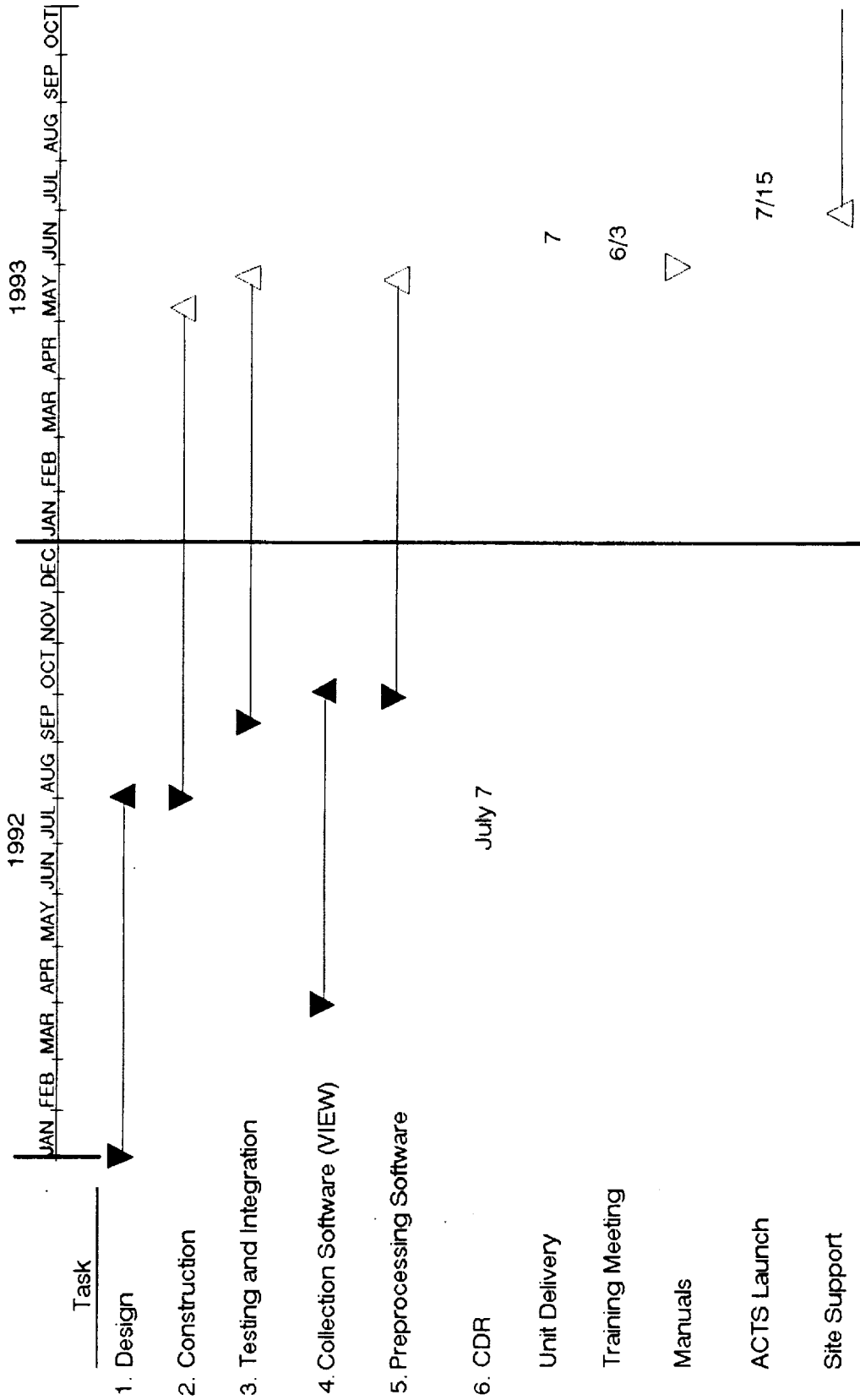

TERMINAL STATUS SUMMARY

Hardware

LNB problems solved by adding an isolator to 20 G channels

Shipping schedule

Week of 6/7: 2 6/14: 2 6/21: 2 6/28: 1

Shipping order

NM, FL, OK, AK, CO, MD, BC

Software

DACS code - complete

ACTSVIEW - complete

20 Hz-rate data development in progress

Documentation

Training Session - Held on 6/3 with full site representation

Hardware Manuals - distributed

ACTSVIEW Code and Manual - distributed

Preprocessing Code and Manual - nearly complete

a:term1.drw
06/09/93

ACTS Propagation Site Support at Virginia Tech

Hardware

- Maintain operational spares for a subassembly swap**
- Maintain documentation including calibration procedures**
- Send updates to experimenters**

Software

- Maintain DRX software, DACS software, VIEW, Preprocessing**
- Send software updates to experimenters by E-mail**

Site Visits

- As necessary for troubleshooting/calibration**

Data Collection/Reduction

- Advise experimenters of S/C changes**
- Process data in same fashion as experimenters**

