

# NAS Technical Summaries

Numerical Aerodynamic  
Simulation Program

March 1991 – February 1992

UNIVERSITY OF CALIFORNIA

BERKELEY

---

The use of color graphics is a powerful and flexible visualization tool for the science of computational fluid dynamics. Without color graphics, the millions of numbers which form the supercomputer solutions to the studies contained in this report and on this cover would be virtually incomprehensible.

---

NASA-TM-109335

National Aeronautics and  
Space Administration

**Ames Research Center**  
Moffett Field, California 94035-1000

**ORIGINAL CONTAINS  
COLOR ILLUSTRATIONS**

(NASA-TM-109335) NAS TECHNICAL  
SUMMARIES: NUMERICAL AERODYNAMIC  
SIMULATION PROGRAM, MARCH 1991 -  
FEBRUARY 1992 (NASA) 266 p

N94-15798

Unclas

G3/01 0191137

457672

266p

# NAS Technical Summaries

Numerical Aerodynamic  
Simulation Program

March 1991 – February 1992

# Preface

NASA created the Numerical Aerodynamic Simulation (NAS) Program in 1987 to focus resources on solving critical problems in aerospace and related disciplines by utilizing the power of the most advanced supercomputers available. The NAS Program provides scientists with the necessary computing power to solve today's most demanding computational fluid dynamics problems and serves as a pathfinder in integrating leading-edge supercomputing technologies, thus benefiting other supercomputer centers in Government and industry.

This report contains selected scientific results from the 1991-92 NAS Operational Year, March 4, 1991 to March 3, 1992, which is the fifth year of operation. During this year, the scientific community was given access to a Cray-2 and a Cray Y-MP. The Cray-2, the first generation supercomputer, has four processors, 256 megawords of central memory, and a total sustained speed of 250 million floating point operations per second. The Cray Y-MP, the second generation supercomputer, has eight processors and a total sustained speed of one billion floating point operations per second. Additional memory was installed this year, doubling capacity from 128 to 256 megawords of solid-state storage-device memory. Because of its higher performance, the Cray Y-MP delivered approximately 77% of the total number of supercomputer hours used during this year.

The DD40 disk drives used for scratch space were replaced by DD4Rs, which provide improved reliability and increased storage capacity. Software improvements were made, including CRI's Data Migration Facility to improve archiving and the NAS-developed Session Reservable File System. The NASStore system

supported researchers' mass storage needs by providing the researchers with a virtually unlimited supply of very fast disk space.

In the first three years of the Program, the number of research projects and the number of scientific researchers increased steadily. However, in the fourth year there was a shift in the resource allocation policy. That year, review committees approved "fewer but bigger projects," although the demand for NAS resources increased dramatically. This shift continued through this year. Increasing the amount of computation time allocated to specific projects allows scientists to direct research toward more computationally intensive efforts and encourages multidisciplinary research.

By the end of the 1991-92 NAS Operational Year, 1,420 researchers conducted 391 research projects at 140 sites representing NASA, the Department of Defense, other Government agencies, private industry, and universities.

The NAS Technical Summaries Report provides an overview of the significant scientific results for the year. Additional copies of the report for this year and previous years are available on request. Please address your request to

NAS Documentation Center  
 NASA Ames Research Center  
 Mail Stop 258-6  
 Moffett Field, CA 94035-1000  
 (415) 604-4632

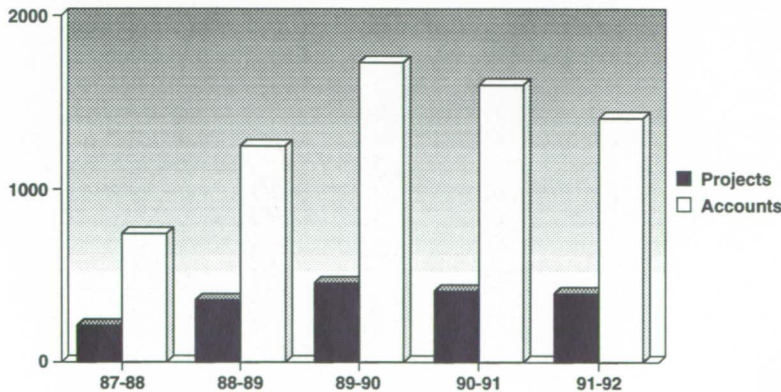

NAS projects and accounts.

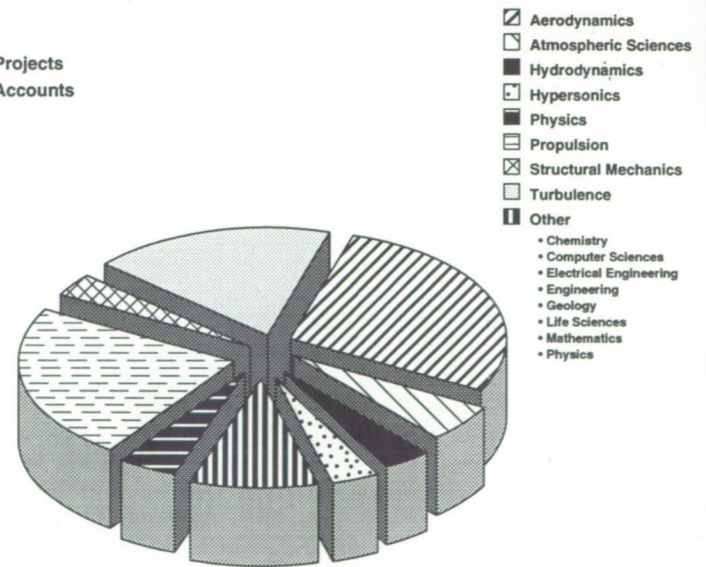

Project disciplines for NAS Operational Year 1991-92.

# Table of Contents

Principal Investigator	NAS Summary	Page
Ramesh K. Agarwal	<i>Numerical Solution of Three-Dimensional Maxwell's Equations</i> ..... Co-Investigators: Mark Shu and Mark R. Axe McDonnell Douglas Research Laboratories	1
Ramesh K. Agarwal	<i>Helicopter Fuselage, Rotor, and Rotor/Body Interaction Flow-Field Calculations</i> ..... Co-Investigator: Jerry E. Deese McDonnell Douglas Research Laboratories	2
Shreekant Agrawal	<i>Numerical Calculation of Vortical Flows</i> ..... Co-Investigator: Brian A. Robinson McDonnell Aircraft Company	3
Jassim A. Al-Saadi	<i>Transonic Reynolds Number Effects on Aircraft Configurations</i> ..... Co-Investigators: Richard A. Wahls, William K. Londenberg, and Melissa B. Rivers NASA Langley Research Center/ViGYAN, Inc.	4
K. Appa	<i>Hydrodynamic Ram Structural Response Analyses</i> ..... Co-Investigator: Wendy S. Pi Northrop Corporation	5
Jeffrey R. Barnes	<i>Nonlinear Baroclinic Instability</i> ..... Co-Investigator: Richard E. Young Oregon State University/NASA Ames Research Center	6
John T. Batina	<i>Euler Flutter Analysis of a Complex Aircraft Configuration</i> ..... Co-Investigator: Russ D. Rausch NASA Langley Research Center/Purdue University	7
Oktay Baysal	<i>Aerodynamic Shape Optimization</i> ..... Co-Investigators: Mohamed E. Eleshaky and Greg W. Burgreen Old Dominion University	8
Diane M. Bell	<i>Turbulent Boundary Layer with Heat Transfer</i> ..... Stanford University	9
Robert F. Bergholz	<i>Three-Dimensional Exhaust-Nozzle Flow Fields for High-Speed Civil Transport</i> ..... Co-Investigator: William M. Turner General Electric Aircraft Engines	10
Marek K. Bleszynski	<i>Electromagnetic Scattering from Large Three-Dimensional Targets</i> ..... Rockwell International Science Center	11
William W. Bower	<i>Short Takeoff and Vertical Landing Aircraft Thermal/Acoustic Loads</i> ..... Co-Investigator: Robert E. Childs McDonnell Douglas Research Laboratories/Nielsen Engineering and Research, Inc.	12
James G. Brasseur	<i>Local Passive Scalar Dispersion in a Turbulent Boundary Layer</i> ..... Co-Investigators: P. K. Yeung, Samir Khanna, and Brian P. Moquin Pennsylvania State University/Georgia Institute of Technology	13
Stephen H. Brecht	<i>Global-Venus/Solar-Wind Interaction</i> ..... Berkeley Research Associates	14

Principal Investigator	NAS Summary	Page
Richard C. Buggeln	<i>Hot-Gas-Manifold Flow Simulation</i> ..... Co-Investigator: Sang-Keun Choi Scientific Research Associates, Inc.	15
Alan B. Cain	<i>Simulation and Modeling of Turbulence and Flow Acoustics</i> ..... Co-Investigators: Dennis F. Fuglsang and Nagi N. Mansour McDonnell Aircraft Company/NASA Ames Research Center	16
Richard L. Campbell	<i>Automated Transonic Wing Design</i> ..... Co-Investigator: Leigh Ann Smith NASA Langley Research Center	17
Brian J. Cantwell	<i>Simulation of a Time-Developing Incompressible Plane Wake</i> ..... Co-Investigators: R. Sondergaard, J. Soria, and J. H. Chen Stanford University/Sandia National Laboratory	18
Frank Caradonna	<i>Prediction of Advanced Rotor Performance</i> ..... Co-Investigators: John Bridgeman and K. Ramachandran U.S. Army Aeroflightdynamics Directorate, AVSCOM/NASA Ames Research Center	19
R. R. Chamberlain	<i>Aerothermal Analysis of Hypersonic Defense Interceptors</i> ..... Co-Investigators: Lawrence W. Spradley and Kenneth E. Xiques Adaptive Research Corporation	20
Dean R. Chapman	<i>Boost-Phase Detection Study</i> ..... Co-Investigators: Forrest E. Lumpkin III, Robert W. MacCormack, and Stephane Moreau Stanford University/NASA Ames Research Center	21
Denny Chaussee	<i>Transonic and Supersonic Flow Past Aircraft Configurations</i> ..... Co-Investigators: Jolen Flores and Eugene Tu NASA Ames Research Center	22
C. L. Chen	<i>Numerical Analysis of Three-Dimensional Separated Juncture Flows</i> ..... Co-Investigator: C. M. Hung Rockwell International Science Center/NASA Ames Research Center	23
H. C. Chen	<i>Euler Analysis of Turboprop and Turbofan Integration</i> ..... Co-Investigators: T. Y. Su, T. J. Kao, and D. A. Naik The Boeing Company/VIGYAN, Inc./NASA Langley Research Center	24
Lee T. Chen	<i>Advanced Transonic Wing Concepts</i> ..... Co-Investigators: K. C. Chang, R. Pelkman, and A. Shmilovich Douglas Aircraft Company	25
Robert E. Childs	<i>Turbulence-Model Development for Impinging Jet Flows</i> ..... Co-Investigator: Laura C. Rodman Nielsen Engineering and Research, Inc.	26
Rodrick V. Chima	<i>Prediction of Turbine Endwall Heat Transfer</i> ..... NASA Lewis Research Center	27
Chuen-Yen Chow	<i>Compressible Taylor-Couette Flow</i> ..... Co-Investigators: Meng-Sing Liou and Kai-Hsiung Kao University of Colorado, Boulder/NASA Lewis Research Center	28

Principal Investigator	NAS Summary	Page
Wei J. Chyu	<i>Airframe and Inlet Aerodynamics</i> ..... Co-Investigators: David A. Caughey and Tom I-P. Shih NASA Ames Research Center/Cornell University/Carnegie Mellon University	29
Charles E. Cockrell, Jr.	<i>Generic National Aero-Space Plane Forebody-Inlet Integration</i> ..... Co-Investigator: Lawrence D. Huebner NASA Langley Research Center	30
William B. Compton, III	<i>Three-Dimensional Afterbody Flow with Jet Exhaust</i> ..... Co-Investigator: Khaled S. Abdol-Hamid NASA Langley Research Center/Analytical Services and Materials, Inc.	31
Raymond R. Cosner	<i>Analyses of F/A-18E/F Upgrades</i> ..... Co-Investigators: F. Creasman, R. S. Dyer, T. D. Gatzke, J. A. Johnson, P. J. Malloy, W. W. Romer, and P. G. Willhite McDonnell Aircraft Company	32
Andrew J. Crook	<i>Endwall and Casing Treatment Flow in a Transonic Fan Rotor</i> ..... General Motors Corporation, Allison Gas Turbine Division	33
Richard D. Crouse	<i>Fighter Acoustic-Load Predictions</i> ..... Northrop Corporation	34
M. I. Cruz	<i>Flexible Aerobrake Aerothermodynamic Study</i> ..... Co-Investigators: D. E. Ressler, T. P. Shivananda, and E. F. Zabrensky TRW, Federal Systems Division/TRW, Ballistic Missiles Division	35
Jeffrey N. Cuzzi	<i>Particle-Gas Dynamics in the Protoplanetary Nebula</i> ..... Co-Investigators: Joelle Champney and Anthony Dobrovolskis NASA Ames Research Center/A.T.M., Inc./University of California, Santa Cruz	36
Russell B. Dahlburg	<i>Dynamical Modeling of the Solar Atmosphere</i> ..... Co-Investigators: S. K. Antiochos, Jill P. Dahlburg, and J. T. Karpen Naval Research Laboratory	37
Sanford M. Dash	<i>Simulation of Turbulent Jets for Aeroacoustic Applications</i> ..... Co-Investigators: Neeraj Sinha, Brian J. York, and Robert A. Lee Science Applications International Corporation	38
Sanford M. Dash	<i>Three-Dimensional High-Speed Plume/Propulsive Flow-Field Analysis</i> ..... Co-Investigators: Neeraj Sinha, Brian J. York, Robert A. Lee, Ashvin Hosagadi, and Donald C. Kenzakowski Science Applications International Corporation	39
Donald W. Davis	<i>Hydrodynamic Performance Evaluation</i> ..... Co-Investigator: Keith C. Kaufman General Dynamics, Electric Boat Division	40
Roger L. Davis	<i>Turbine "Hot Spot" Alleviation using Film Cooling</i> ..... Co-Investigator: Daniel J. Dorney United Technologies Research Center	41
Russell G. DeAnna	<i>Transition over a Rough Surface</i> ..... Co-Investigator: Eli Reshotko U.S. Army Propulsion Directorate, AVSCOM/Case Western Reserve University	42

Principal Investigator	NAS Summary	Page
Jerry E. Deese	<i>Flow about Almost Complete Aircraft and Hypersonic Configurations</i> ..... Co-Investigators: Ramesh K. Agarwal, Thomas P. Gielda, Jerry G. Johnson, and Mark Axe McDonnell Douglas Research Laboratories/NASA Ames Research Center	43
Robert G. Deissler	<i>Sensitivity of Turbulence to Initial Conditions</i> ..... Co-Investigator: Frank B. Molls NASA Lewis Research Center	44
G. S. Deiwert	<i>Self-Adaptive Grid Code Applied to Complex Three-Dimensional Flows</i> ..... Co-Investigators: Carol B. Davies and Ethiraj Venkatapathy NASA Ames Research Center/Sterling Software/Eloret Institute	45
A. O. Demuren	<i>Complex Three-Dimensional Turbulent Flows</i> ..... Old Dominion University.	46
Virendra K. Dogra	<i>Rarefied Hypersonic Condition Wake Structures</i> ..... Co-Investigators: Richard G. Wilmoth, James N. Moss, and Joseph M. Price ViGYAN, Inc./NASA Langley Research Center	47
J. Philip Drummond	<i>Fuel–Air Mixing Enhancement by Jet–Shock Interactions</i> ..... Co-Investigators: Peyman Givi, Cyrus K. Madnia, and Craig J. Steinberger NASA Langley Research Center	48
C. T. Edquist	<i>Aerobraking Studies of Three-Dimensional Nonequilibrium Viscous Flow</i> ..... Co-Investigator: T. J. Galambos Martin Marietta Astronautics Group	49
Thomas A. Edwards	<i>Aerodynamic Optimization of Supersonic Transport Aircraft</i> ..... Co-Investigator: Samson H. Cheung NASA Ames Research Center/MCAT Institute	50
T. Alan Egolf	<i>Rotary-Wing Airload Performance Prediction</i> ..... Co-Investigator: Brian E. Wake United Technologies Research Center	51
Dean R. Eklund	<i>Transpiration Cooling for Scramjet Combustor Flow Fields</i> ..... National Research Council/NASA Langley Research Center	52
Larry L. Erickson	<i>Flow Solver for Euler Equations on Unstructured Tetrahedral Meshes</i> ..... Co-Investigator: M. Jahed Djomehri NASA Ames Research Center/Eloret Institute	53
William J. Feiereisen	<i>Discrete Particle Simulation of Compressible Flow</i> ..... Co-Investigators: Jeffrey McDonald, Brian Haas, Iain Boyd, Donald Baganoff, Michael Fallavollita, Terry Denery, and Avijit Goswami NASA Ames Research Center/Stanford University	54
William J. Feiereisen	<i>Aeroassist Flight Experiment Flow Simulation</i> ..... Co-Investigators: G. E. Palmer, E. Venkatapathy, D. S. Babikian, D. K. Prabhu, and E. E. Whiting NASA Ames Research Center	55
Michael C. Fischer	<i>F16xL Supersonic Laminar Low-Control Experiment</i> ..... Co-Investigator: Chandra S. Vemuru NASA Langley Research Center	56

Principal Investigator	NAS Summary	Page
Neal T. Frink	<i>Analysis of Slender-Wing Geometries using Unstructured Grids</i> ..... Co-Investigators: Paresh Parikh and Shahyar Pirzadeh NASA Langley Research Center	57
Datta Gaitonde	<i>Turbulent Flow Past a Complete Hypersonic Reentry Configuration</i> ..... Co-Investigator: Joseph Shang WL/FIMM, Wright Patterson AFB	58
Joseph L. Garrett	<i>Integrated Hypersonic-Propulsion Flow Paths</i> ..... Co-Investigators: Kevin Van Dyke and Balu Sukar Pratt & Whitney/General Electric Aircraft Engines	59
Thomas B. Gatski	<i>Compressible Turbulent Flows</i> ..... Co-Investigator: Joseph H. Morrison NASA Langley Research Center	60
Peter A. Gnoffo	<i>Hypersonic Flows in Chemical and Thermal Nonequilibrium</i> ..... NASA Langley Research Center	61
Raymond Gordnier	<i>Unsteady Delta-Wing Flow</i> ..... WL/FIMM, Wright Patterson AFB	62
Isaac Greber	<i>Numerical Calculation of a Three-Dimensional Separated Flow</i> ..... Case Western Reserve University	63
Fernando F. Grinstein	<i>Spatially Evolving Reactive Jets</i> ..... Naval Research Laboratory	64
W. L. Grose	<i>Three-Dimensional Atmospheric Simulation Model</i> ..... Co-Investigators: W. T. Blackshear, R. S. Eckman, and R. E. Turner NASA Langley Research Center	65
Karen L. Gundy-Burlet	<i>Rotor–Stator Interaction in Turbomachines</i> ..... Co-Investigator: Akil Rangwalla NASA Ames Research Center	66
Guru P. Guruswamy	<i>Fluid and Structure Integration for Aerospace Applications</i> ..... Co-Investigator: Shigeru Obayashi NASA Ames Research Center	67
Karl E. Gustafson	<i>Airfoil Lift and Thrust Generation in Hover Mode</i> ..... Co-Investigator: Robert R. Leben University of Colorado, Boulder	68
Edward J. Hall	<i>Unsteady Counterrotation of Ducted Propfans</i> ..... General Motors Corporation, Allison Gas Turbine Division	69
David Halpern	<i>Satellite Data Assimilation and Ocean General Circulation Models</i> ..... Co-Investigators: Y. Chao and C. Roberto Mechoso Jet Propulsion Laboratory/University of California, Los Angeles	70
David Halpern	<i>Atmospheric General Circulation Model Sensitivity to Sea Surface Temperature Fields</i> ..... Co-Investigators: C. Roberto Mechoso and Robert Haskins Jet Propulsion Laboratory/University of California, Los Angeles	71

Principal Investigator	NAS Summary	Page
David W. Halt	<i>Transonic Analysis on Unstructured Grids</i> .....72 McDonnell Aircraft Company/McDonnell Douglas Research Laboratories	
H. Harris Hamilton	<i>Radiative Structure in Aerobrake Shock Layers</i> .....73 Co-Investigator: Robert B. Greendyke NASA Langley Research Center/ViGYAN, Inc.	
Jeff L. Hansen	<i>Incorporation of a Three-Dimensional Multistage Viscous Code into a Compressor Design System</i> .....74 Co-Investigator: John Adamczyk General Motors Corporation, Allison Gas Turbine Division/NASA Lewis Research Center	
Julius E. Harris	<i>Swept-Wing Leading-Edge Transition</i> .....75 Co-Investigator: Venkit Iyer NASA Langley Research Center/ViGYAN Inc.	
Lin C. Hartung	<i>Radiation Transport around Axisymmetric Blunt-Body Vehicles</i> .....76 NASA Langley Research Center	
H. A. Hassan	<i>New Approach for Transitional-Flow Modeling</i> .....77 Co-Investigators: T. Wayne Young and Eric S. Warren North Carolina State University	
James D. Holdeman	<i>Hot-Gas Ingestion by a Short Takeoff and Vertical Landing Aircraft in Ground Proximity</i> .....78 Co-Investigators: David M. Fricker and S. Pratap Vanka NASA Lewis Research Center/University of Illinois, Urbana/Champaign	
Yeu-Chuan Hsia	<i>Full Navier–Stokes Analysis of a Three-Dimensional Scramjet Inlet</i> .....79 Co-Investigators: Endwell Daso and Sukumar Chakravarthy Rockwell International, Rocketdyne Division/Rockwell International Science Center	
Carl T. Hsieh	<i>High Angle-of-Attack Missile Aerodynamics</i> .....80 Naval Surface Warfare Center	
Thomas T. Huang	<i>Submarine-Appendage Design and Turbulence Modeling</i> .....81 Co-Investigators: Michael Griffin, Jeff Tsai, William Smith, and Dane Hendrix Naval Surface Warfare Center/Jason Associates/Scientific Research Associates, Inc./MCAT Institute	
Lawrence D. Huebner	<i>Generic National Aero-Space Plane Fuselage Configuration Study</i> .....82 Co-Investigator: Kenneth E. Tatum NASA Langley Research Center/Lockheed Engineering and Sciences Company	
Joseph W. Humphrey	<i>Hypersonic Scramjet and Detonation Flows</i> .....83 Co-Investigators: Darrell W. Pepper, Thomas H. Sobota, Frank P. Brueckner, Barry Dyne, and Juan C. Heinrich Advanced Projects Research, Inc./University of Arizona/NASA Langley Research Center	
Fazle Hussain	<i>Coherent-Structure Interactions with Turbulence</i> .....84 Co-Investigator: Mogens V. Melander University of Houston/Southern Methodist University	
Fazle Hussain	<i>Chemically Reacting Free-Shear Flows</i> .....85 Co-Investigators: Ralph Metcalfe and Fernando Grinstein University of Houston/Naval Research Laboratory	

Principal Investigator	NAS Summary	Page
Scott T. Imlay	<i>Aero-Assisted Orbital Transfer Vehicle Flow Fields</i> ..... Co-Investigators: Donald W. Roberts and Moeljo Soetrisno Amtec Engineering, Inc.	86
Gregory A. Intemann	<i>Wing–Nacelle–Pylon Installations</i> ..... Co-Investigator: Todd R. Michal Douglas Aircraft Company/McDonnell Aircraft Company	87
Kenneth M. Jones	<i>Analysis of High-Speed Civil Transport Configurations</i> ..... Co-Investigators: Victor R. Lessard and M. A. Takallu NASA Langley Research Center/ViGYAN, Inc./Lockheed Engineering and Sciences Company	88
K. Kailasanath	<i>Structure and Dynamics of Multidimensional Flames</i> ..... Co-Investigator: G. Patnaik Naval Research Laboratory	89
K. Kailasanath	<i>Unsteady Nozzle Flow Fields</i> ..... Co-Investigator: R. Ramamurti Naval Research Laboratory	90
Osama A. Kandil	<i>Simulation and Control of Slender Wing Rock</i> ..... Co-Investigator: Ahmed A. Salman NASA Lewis Research Center/Old Dominion University	91
Carolyn R. Kaplan	<i>Unsteady Ethylene Jet-Diffusion Flames</i> ..... Co-Investigators: Elaine S. Oran and Seung W. Baek Naval Research Laboratory/Korea Advanced Institute of Science and Technology	92
Steve L. Karman, Jr.	<i>Unstructured Grid-Generation/Flow-Solver Calibration</i> ..... Co-Investigator: Gregory S. Spragle General Dynamics, Fort Worth Division	93
George E. Karniadakis	<i>Turbulent Flow over Riblet-Mounted Surfaces</i> ..... Princeton University	94
G. E. Karniadakis	<i>Turbulent Flow over a Backward-Facing Step</i> ..... Co-Investigator: S. A. Orszag Princeton University	95
Jack H. Kennedy	<i>Aeronautical Vehicle Radar Cross Sections</i> ..... Co-Investigator: Daniel A. White General Dynamics, Convair Division	96
Christian L. Keppen	<i>Orographically Forced Oscillations of the Martian Atmosphere</i> ..... Co-Investigator: Jean O. Dickey Jet Propulsion Laboratory	97
Suk C. Kim	<i>Low-Thrust Chemical Rockets</i> ..... Sverdrup Technology, Inc./NASA Lewis Research Center	98
S. W. Kim	<i>Fluid Flow of Jets in Cross Flow</i> ..... Co-Investigator: T. J. Benson NASA Lewis Research Center	99

Principal Investigator	NAS Summary	Page
Kevin R. Kirtley	<i>Multistage Turbomachinery Flows</i> ..... Co-Investigators: John J. Adamczyk, Tim A. Beach, Mark L. Celestina, William A. Maul, and Rick A. Mulac Sverdrup Technology, Inc./NASA Lewis Research Center	100
W. Kollmann	<i>Turbulent Boundary Layers with Suction</i> ..... Co-Investigator: P. Mariani University of California, Davis	101
Linda D. Kral	<i>Receptivity, Transition, and Turbulence Phenomena</i> ..... Co-Investigators: William W. Bower and Alexander Pal McDonnell Douglas Research Laboratories	102
Linda D. Kral	<i>Turbulence Modeling for Three-Dimensional Flow Fields</i> ..... Co-Investigator: John A. Ladd McDonnell Douglas Research Laboratories/McDonnell Aircraft Company	103
Ajay Kumar	<i>Translating-Strut Scramjet Inlet</i> ..... Co-Investigator: Dal J. Singh NASA Langley Research Center	104
Dochan Kwak	<i>High-Lift Aerodynamic Flow</i> ..... Co-Investigators: Stuart Rogers and Lyn Wiltberger NASA Ames Research Center	105
Dochan Kwak	<i>Space Shuttle Main Engine Flow</i> ..... Co-Investigators: S. Yoon, C. Kiris, L. Chang, and R. Williams NASA Ames Research Center	106
H. T. Lai	<i>Hydrogen–Air Reacting Flow Fields in Drag Reduction External Combustion</i> ..... Sverdrup Technology, Inc.	107
Budugur Lakshminarayana	<i>Steady and Unsteady Turbomachinery Flow Fields</i> ..... Co-Investigators: S. Fan and R. Kunz Pennsylvania State University/General Motors Technical Center	108
Budugur Lakshminarayana	<i>Steady and Unsteady Viscous Flow</i> ..... Co-Investigators: Yin-Hsiang Ho and Anton Basson Pennsylvania State University	109
Scott L. Lawrence	<i>Integrated Hypersonic Vehicle Flow-Field Analysis</i> ..... Co-Investigators: Bradford C. Bennett and Gregory A. Molvik NASA Ames Research Center/MCAT Institute	110
C. C. Lee	<i>Numerical Investigation of Vehicles Similar to the National Aero-Space Plane</i> ..... Co-Investigators: William Bower, Shawn Hagmeier, Brad Hopping, Morzata Mani, Scott Van Horn, Charles Vaporean, Patrick Vogel, and Darrell Weber McDonnell Douglas Corporation	111
Elizabeth M. Lee	<i>Subsonic/Transonic Flutter Boundaries</i> ..... Co-Investigator: Mike Gibbons NASA Langley Research Center/Lockheed Engineering and Sciences Company	112

Principal Investigator	NAS Summary	Page
Sang Soo Lee	<i>Resonant-Triad Interaction in an Adverse Pressure-Gradient Boundary Layer</i> ..... Co-Investigator: M. E. Goldstein Sverdrup Technology, Inc./NASA Lewis Research Center	113
Yu-Tai Lee	<i>Unsteady Flows for Naval Applications</i> ..... Naval Surface Warfare Center	114
Sanjiva K. Lele	<i>Skewed Compressible Mixing Layers</i> ..... Stanford University	115
Sanjiva K. Lele	<i>Turbulence Effects on Stagnation-Point Flow</i> ..... Stanford University	116
Clark H. Lewis	<i>Three-Dimensional Parabolized and Full Navier–Stokes Techniques</i> ..... Co-Investigator: Bilal A. Bhutta VRA, Inc.	117
C. S. Lin	<i>Electron-Beam Injections from the Space Shuttle</i> ..... Co-Investigator: M. Muller Aurora Science, Inc./Southwest Research Institute	118
S. J. Lin	<i>Turbopump Rotor/Stator Flows</i> ..... Rockwell International, Rocketdyne Division	119
James M. Luckring	<i>Advanced Computational Fluid Dynamics Applications for Complex Configurations</i> ..... Co-Investigators: Farhad Ghaffari and Brent L. Bates NASA Langley Research Center	120
M. G. Macaraeg	<i>Ignition and Structure of a Diffusion Flame with Vortex Interaction</i> ..... Co-Investigators: T. L. Jackson and M. Y. Hussaini NASA Langley Research Center/Old Dominion University/ICASE	121
Robert D. MacElroy	<i>Computer Simulation of Water–Membrane Interfaces</i> ..... Co-Investigators: Andrew Pohorille and Michael A. Wilson NASA Ames Research Center	122
M. R. Malik	<i>Supersonic Boundary-Layer Transition on a Cone at Incidence</i> ..... Co-Investigator: P. Balakumar High Technology Corporation/NASA Langley Research Center	123
M. R. Malik	<i>Compressible Boundary-Layer Transition</i> ..... Co-Investigator: C. L. Chang High Technology Corporation/NASA Langley Research Center	124
Nagi N. Mansour	<i>Turbulence in Compressible Fluids</i> ..... Co-Investigator: Gary N. Coleman NASA Ames Research Center	125
David L. Marcum	<i>Flow-Field Calculations using Unstructured Grids</i> ..... Co-Investigators: Ramesh K. Agarwal and David W. Halt Mississippi State University/McDonnell Douglas Research Laboratories	126

Principal Investigator	NAS Summary	Page
Fred W. Martin, Jr.	<i>Space Shuttle Flow Field</i> ..... Co-Investigators: Pieter Buning, Steve Labbe, Ray Gomez, Jeff Slotnick, Steve Parks, and Max Kandula NASA Johnson Space Center/NASA Ames Research Center	127
Dimitri J. Mavriplis	<i>Multigrid Solution of the Euler Equations</i> ..... ICASE/NASA Langley Research Center	128
Charles R. McClinton	<i>High Mach-Number Mixing in a Shock Tunnel Environment</i> ..... Co-Investigator: Robert D. Bittner NASA Langley Research Center/Analytical Services and Materials, Inc.	129
Charles R. McClinton	<i>National Aero-Space Plane Configuration Trade Studies</i> ..... Co-Investigators: Arthur D. Dilley and Richard W. Hawkins NASA Langley Research Center/Analytical Services and Materials, Inc.	130
Charles R. McClinton	<i>Scramjet Inlet Interaction</i> ..... Co-Investigators: Thomas N. Jentink and Arthur D. Dilley NASA Langley Research Center/Analytical Services and Materials, Inc.	131
Charles R. McClinton	<i>Scramjet Engine Design Optimization</i> ..... Co-Investigators: Pradeep S. Kamath and Marlon Mao NASA Langley Research Center/Analytical Services and Materials, Inc.	132
W. J. McCroskey	<i>Aerodynamics and Acoustics of Rotorcraft</i> ..... Co-Investigators: J. D. Baeder, V. Raghavan, G. R. Srinivasan, and S. K. Stanaway U.S. Army Aeroflightdynamics Directorate, AVSCOM/NASA Ames Research Center	133
W. J. McCroskey	<i>High-Performance Rotor-Blade Tips</i> ..... Co-Investigators: E. P. N. Duque, V. Raghavan, G. R. Srinivasan, and R. C. Strawn U.S. Army Aeroflightdynamics Directorate, AVSCOM/NASA Ames Research Center	134
Suresh Menon	<i>Active Control of Ramjet Combustion Instability</i> ..... QUEST Integrated, Inc.	135
Charles L. Merkle	<i>Coupled Navier–Stokes Maxwell Analysis for Microwave Propulsion</i> ..... Co-Investigator: S. Venkateswaran Pennsylvania State University	136
Parviz Moin	<i>Turbulent Flow Over Riblets</i> ..... Co-Investigators: John Kim and Haecheon Choi Stanford University/NASA Ames Research Center	137
Parviz Moin	<i>Turbulence Over a Backward-Facing Step</i> ..... Co-Investigators: John Kim and Hung Le NASA Ames Research Center	138
Parviz Moin	<i>Aerodynamic Sound Generation</i> ..... Co-Investigators: Sanjiva K. Lele, Tim Colonius, and Brian E. Mitchell Stanford University/NASA Ames Research Center	139
Parviz Moin	<i>Shock-Wave/Turbulent-Boundary-Layer Interaction</i> ..... Co-Investigators: Sanjiva K. Lele, Mahesh Krishnan, and Sangsan Lee Stanford University/NASA Ames Research Center/Center for Turbulence Research	140

Principal Investigator	NAS Summary	Page
Robert D. Moser	<i>Wall-Bounded Turbulent Flows</i> ..... Co-Investigator: John Kim NASA Ames Research Center	141
James N. Moss	<i>Hypersonic Rarefied Flow about a Compression Ramp</i> ..... Co-Investigator: Joseph M. Price NASA Langley Research Center	142
Jon S. Mounts	<i>Transonic-Shock/Boundary-Layer Interaction to Alleviate Separation</i> ..... Co-Investigator: Thomas J. Barber United Technologies Research Center	143
J. C. Narramore	<i>Rotorcraft Drag Prediction</i> ..... Co-Investigators: A. G. Brand and D. W. Axley Bell Helicopter Textron, Inc.	144
David Nixon	<i>Controlling Combustion in Free-Shear Layers</i> ..... Co-Investigator: Laurence Keef Nielsen Engineering and Research, Inc.	145
Ahmed K. Noor	<i>Thermomechanical Buckling and Post-Buckling of Multilayered Composite Panels with Cutouts</i> ..... Co-Investigator: Jeanne M. Peters NASA Langley Research Center/University of Virginia	146
Grant Palmer	<i>Space Transportation Vehicle Aerothermodynamics</i> ..... Co-Investigators: Susan Tokarcik, Ethiraj Venkatapathy, and William J. Feiereisen NASA Ames Research Center	147
Ajay K. Pandey	<i>Thermo-Viscoplastic Analysis of an Engine-Cowl Leading Edge</i> ..... Lockheed Engineering and Sciences Company/NASA Langley Research Center	148
S. Paul Pao	<i>Afterbody Aerodynamics with Canted Pitch-Vectoring Twin Nozzles</i> ..... Co-Investigator: K. S. Abdol-Hamid NASA Langley Research Center/Analytical Services and Materials, Inc.	149
V. C. Patel	<i>Hydrodynamics of Self-Propelled Bodies</i> ..... Co-Investigator: F. Stern University of Iowa	150
Darrell W. Pepper	<i>Hypersonic Scramjet Flow</i> ..... Co-Investigators: Frank P. Brueckner and Kevin L. Burton Advanced Projects Research, Inc.	151
Leonhard Pfister	<i>Wave-Induced Transports</i> ..... NASA Ames Research Center	152
Thanh T. Phan	<i>Rocket-Base Flow-Field Simulations</i> ..... Co-Investigator: Richard J. Magnus General Dynamics, Space Systems Division	153
Richard H. Pletcher	<i>Three-Dimensional Liquid-Sloshing Flows</i> ..... Co-Investigators: Franklyn J. Kelecny and Babu Sethuraman Iowa State University	154

Principal Investigator	NAS Summary	Page
James B. Pollack	<i>Martian Atmosphere General Circulation</i> ..... Co-Investigator: Robert Haberle NASA Ames Research Center	155
Greg D. Power	<i>Three-Dimensional Scramjet Combustors</i> ..... Co-Investigator: Thomas J. Barber United Technologies Research Center	156
Ramadas K. Prabhu	<i>Hypersonic-Flow Computations using Adaptive Unstructured Meshes</i> ..... Lockheed Engineering and Sciences Company/NASA Langley Research Center	157
C. D. Pruett	<i>Laminar Breakdown of High-Speed Boundary-Layer Flow</i> ..... Co-Investigator: T. A. Zang Analytical Services and Materials, Inc./NASA Langley Research Center	158
R. Ramakrishnan	<i>Shock Impingement in Hypersonic Engine Inlets</i> ..... NASA Langley Research Center	159
Edward J. Reske	<i>Complex Three-Dimensional Flows in the Advanced Solid-Rocket Motor</i> ..... Co-Investigators: Dana F. Billings and Joni W. Cornelison NASA Marshall Space Flight Center	160
David L. Rigby	<i>Leading-Edge Heat Transfer in a Flow with Spanwise Variations</i> ..... Sverdrup Technology, Inc.	161
Charles L. Rino	<i>Scattering from Ocean Surfaces and Near-Surface Objects</i> ..... Co-Investigators: Hoc D. Ngo, Thomas L. Crystal, and Carl E. Hess Vista Research, Inc.	162
R. P. Roger	<i>Jet Interaction Aero-Optic Effects on Hypersonic Interceptors</i> ..... Co-Investigator: S. C. Chan Teledyne Brown Engineering	163
Michael M. Rogers	<i>Mixing and Reacting in Plane Mixing Layers</i> ..... Co-Investigators: Robert D. Moser, S. Scott Collis, and Chris Rutland NASA Ames Research Center/Stanford University/University of Wisconsin, Madison	164
R. Clayton Rogers	<i>Hypervelocity Mixing and Combustion in Pulse Facility Flows</i> ..... Co-Investigators: David W. Riggins, Robert D. Bittner, and Glenn J. Bobskill NASA Langley Research Center/University of Missouri, Rolla/ Analytical Services and Materials, Inc.	165
William C. Rose	<i>Hypersonic Inlet Flow Fields</i> ..... NASA Ames Research Center	166
William C. Rose	<i>National Aero-Space Plane Inlet Boundary-Layer Control</i> ..... NASA Lewis Research Center	167
William C. Rose	<i>National Aero-Space Plane Inlet Flow Fields</i> ..... NASA Ames Research Center	168
James C. Ross	<i>Trapped-Vortex Flows on Highly Swept Wing Configurations</i> ..... Co-Investigators: Paula Lovely and Todd Riddle NASA Ames Research Center	169

Principal Investigator	NAS Summary	Page
Karlin R. Roth	<i>Validation of a Short Takeoff and Vertical Landing Model</i> ..... Co-Investigator: Stephen Chiu NASA Ames Research Center/California Polytechnic State University, San Luis Obispo	170
Stephen M. Ruffin	<i>Coupled Rotation–Vibration–Dissociation Processes in Hypersonic Flows</i> ..... Co-Investigators: Surendra P. Sharma and Ellis Whiting NASA Ames Research Center	171
Christopher L. Rumsey	<i>High-Alpha Flow Fields</i> ..... Co-Investigators: James L. Thomas, Robert T. Biedron, Sherrie L. Krist, W. Kyle Anderson, Daryl L. Bonhaus, David L. Whitaker, Thomas W. Roberts, Gary P. Warren, Beyung Kim, and Robert P. Weston NASA Langley Research Center	172
Jose M. Sanz	<i>Aerodynamic Inverse Design and Analysis for a Full Engine</i> ..... NASA Lewis Research Center	173
Lewis B. Schiff	<i>High Alpha Technology Program F-18 Aerodynamics</i> ..... Co-Investigators: Yehia Rizk, Ken Gee, and Scott Murman NASA Ames Research Center	174
Lewis B. Schiff	<i>High Angle-of-Attack Vortex Flow Aerodynamics</i> ..... Co-Investigators: Yehia Rizk, Neal Chaderjian, David Degani, John Ekaterinaris, Yuval Levy, and Gabriel Font NASA Ames Research Center	175
Balu Sekar	<i>Viscous Non-Reacting Flows in High-Speed Combustors</i> ..... Co-Investigators: Douglas Davis and Daniel Risha WL/FIMM, Wright Patterson AFB	176
Vijaya Shankar	<i>Computational Fluid Dynamics Approach to Computational Electromagnetics</i> ..... Co-Investigators: William F. Hall, Alireza Mohammadian, and Chris Rowell Rockwell International Science Center	177
Samuel P. Shanks	<i>Computational Fluid Dynamics of Store Separation</i> ..... Co-Investigator: Jasim U. Ahmad JAI Associates, Inc.	178
Tom I-P. Shih	<i>Wankel Engine Flow Fields</i> ..... Co-Investigators: E. Steinthorsson, Z. Li, A. Karadag, E. A. Willis, and J. McFadden Carnegie Mellon University/NASA Lewis Research Center	179
B. A. Singer	<i>Formation and Growth of Hairpin Vortices</i> ..... Co-Investigators: R. D. Joslin and S. P. G. Dinavahi NASA Langley Research Center	180
Brian R. Smith	<i>Computational Fluid Dynamics Methods for Highly Maneuverable Aircraft</i> ..... Co-Investigators: C. L. Reed and A. Muyschondt General Dynamics, Fort Worth Division	181
Bruce F. Smith	<i>Numerical Experiments in the Formation and Evolution of Galaxies</i> ..... Co-Investigator: Richard H. Miller NASA Ames Research Center/University of Chicago	182

Principal Investigator	NAS Summary	Page
Merritt H. Smith	<i>YAV-8B Aircraft Flow Simulation</i> ..... Co-Investigators: Kalpana Chawla and William R. Van Dalsem NASA Ames Research Center	183
Robert E. Smith	<i>Grid Generation for Aerodynamic Configurations</i> ..... Co-Investigator: Michael J. Bockelie NASA Langley Research Center/GEOLAB	184
K. Snyder	<i>National Aero-Space Plane High-Speed Combustion Experiment</i> ..... Co-Investigators: J.-L. Cambier, D. K. Prabhu, and S. Tokarcik NASP Joint Program Office/NASA Ames Research Center	185
Philippe R. Spalart	<i>Complex Turbulent Boundary Layers</i> ..... Boeing Commercial Airplane Group	186
Fred Stern	<i>Free-Surface Effects on Boundary Layers and Wakes</i> ..... University of Iowa	187
Eric T. Stewart	<i>Space Station Freedom Internal Flow Analysis</i> ..... Co-Investigator: Lee A. Kania NASA Marshall Space Flight Center/Sverdrup Technology, Inc.	188
Olaf O. Storaasli	<i>Parallel-Vector "Out-of-Core" Equation Solver</i> ..... NASA Langley Research Center	189
Michael W. Stortz	<i>Harrier YAV-8B Wing Aerodynamics</i> ..... Co-Investigators: Lie-Mine Gea and Gil W. Chyu NASA Ames Research Center	190
Sundares V. Subramanian	<i>Viscous Reacting-Flow Applications to Scramjet Propulsion</i> ..... Co-Investigator: Richard J. Gaeta, Jr. General Electric Aircraft Engines	191
Dennis Sullivan	<i>Microwave Hyperthermia Computer Modeling</i> ..... Stanford University School of Medicine	192
Chao-Ho Sung	<i>Computational Fluid Dynamics for Naval Applications</i> ..... Co-Investigators: Michael J. Griffin, Chi-Wang Shu, and George T. Yeh David Taylor Research Center	193
R. C. Swanson	<i>Simulation of Scramjet Flow Fields</i> ..... Co-Investigator: E. Turkel NASA Langley Research Center	194
Tsze C. Tai	<i>Low-Speed Aircraft Maneuvering Aerodynamics</i> ..... Naval Surface Warfare Center	195
Rajiv Thareja	<i>Unstructured Multigrid Euler Solver</i> ..... Co-Investigators: J. Peraire, J. Peiro, and K. Morgan Lockheed Engineering and Sciences Company/Imperial College/University College, Wales	196
Gary E. Thomas	<i>Multi-Dimensional Simulations of Noctilucent Cloud Formation</i> ..... Co-Investigator: Eric J. Jensen University of Colorado, Boulder/NASA Ames Research Center	197

Principal Investigator	NAS Summary	Page
Owen B. Toon	<i>Stratospheric Ozone Destruction</i> ..... NASA Ames Research Center	198
Ban H. Tran	<i>Radar Cross-Section Studies</i> ..... Rockwell International, North American Aircraft Division	199
Arnaud Trouvé	<i>Turbulent Premixed Combustion</i> ..... Co-Investigator: Thierry Poinso NASA Ames Research Center/Stanford University	200
Eli Turkel	<i>Multigrid Solution of the Navier–Stokes Equations</i> ..... ICASE/NASA Langley Research Center	201
Walter O. Valarezo	<i>Multi-Element High-Lift Concepts</i> ..... Co-Investigators: Vincent D. Chin and Dimitri J. Mavriplis Douglas Aircraft Company/NASA Langley Research Center/ICASE	202
W. R. Van Dalsem	<i>Simulation of the Unsteady Flow about Transonic Cavities</i> ..... Co-Investigators: C. A. Atwood, S. P. Klotz, and D. Sondak NASA Ames Research Center/MCAT Institute	203
W. R. Van Dalsem	<i>Powered-Lift Computational Fluid Dynamics Project</i> ..... Co-Investigator: K. Chawla NASA Ames Research Center/MCAT Institute	204
Veer N. Vatsa	<i>High-Reynolds-Number Viscous Flow over Aircraft Components</i> ..... Co-Investigator: Eli Turkel NASA Langley Research Center	205
Gururaja R. Vemaganti	<i>Two-Equation Turbulence Model Implementation</i> ..... Lockheed Engineering and Sciences Company	206
Bill J. Walker	<i>Tactical Missile Aero-Propulsion Interaction</i> ..... Co-Investigators: C. D. Mikkelsen, K. D. Kennedy, P. F. Booth, and M. E. Vaughn, Jr. U.S. Army Missile Command	207
Robert W. Walters	<i>Finite-Rate Chemistry Algorithms</i> ..... Co-Investigators: Bernard Grossman, Michael Applebaum, Andrew S. Godfrey, William D. McGrory, and David C. Slack Virginia Polytechnic Institute and State University	208
Jong H. Wang	<i>Hydrocarbon Scramjet Combustor Flows</i> ..... Rockwell International, North American Aircraft Division	209
Kurt F. Weber	<i>Flow Simulation in Fan and Core Compressor Stages</i> ..... Co-Investigator: Dale W. Thoe General Motors Corporation, Allison Gas Turbine Division	210
Kenneth J. Weilmuenster	<i>Winged Entry-Vehicle Computations</i> ..... Co-Investigators: Francis A. Greene and William L. Kleb NASA Langley Research Center	211
Kenneth J. Weilmuenster	<i>Shuttle Leeside Temperature Study</i> ..... Co-Investigator: William L. Kleb NASA Langley Research Center	212

Principal Investigator	NAS Summary	Page
Douglas L. Westphal	<i>Tropospheric Aerosols and Clouds</i> ..... Co-Investigator: Owen B. Toon NASA Ames Research Center	213
J. A. White	<i>Supersonic Chemically Reacting Turbulent Flow</i> ..... Co-Investigators: J. P. Drummond, J. J. Korte, and M. H. Carpenter NASA Langley Research Center	214
Richard G. Wilmoth	<i>Shock Interactions in Hypersonic Rarefied Flows</i> ..... Co-Investigators: V. K. Dogra and J. N. Moss NASA Langley Research Center/ViGYAN, Inc.	215
Chung-Jin Woan	<i>Supersonic Laminar Flow Control Concept</i> ..... Co-Investigators: Michael W. George and Philip B. Gingrich Rockwell International, North American Aircraft Division	216
Chung-Jin Woan	<i>Nozzle Screech Phenomena</i> ..... Co-Investigator: Michael W. George Rockwell International, North American Aircraft Division	217
J. P. Wolfe	<i>Advanced Computational Materials Research</i> ..... Co-Investigators: R. Averbach, J. Kogut, and P. Wolyne University of Illinois, Urbana/Champaign	218
Alex C. Woo	<i>Computational Electromagnetics</i> ..... Co-Investigators: Michael J. Schuh and Michael P. Simon NASA Ames Research Center	219
Perry A. Wooden	<i>Numerical Simulation of the PAMPA Jet Trainer</i> ..... Co-Investigator: Ronald D. Lowe LTV, Aircraft Division	220
Cheng-I Yang	<i>Numerical Simulation of Submarine Propulsion</i> ..... David Taylor Research Center	221
David T. Yeh	<i>Steady and Unsteady Flows at High Angle of Attack</i> ..... Co-Investigator: Hiroshi Ide Rockwell International, North American Aircraft Division	222
Richard E. Young	<i>Volcanic Aerosol Clouds in the Stratosphere</i> ..... Co-Investigators: Howard Houben and Owen B. Toon NASA Ames Research Center/Space Physics Research Institute	223
Shaye Yungster	<i>Single Expansion Ramp Nozzle with External Burning</i> ..... ICOMP/NASA Lewis Research Center	224
T.A. Zang	<i>Transition Modeling</i> ..... Co-Investigators: S. Dinavahi, U. Piomelli, R. Garg, and K. Ball NASA Langley Research Center/University of Maryland/University of Texas	225
Index by Research Sites	.....	227

# Numerical Solution of Three-Dimensional Maxwell's Equations

Ramesh K. Agarwal, Principal Investigator  
Co-Investigators: Mark Shu and Mark R. Axe  
McDonnell Douglas Research Laboratories

## Research Objective

To develop computational codes capable of predicting the electromagnetic (EM) signature of an aerospace vehicle. Such a code would be of great value in the design and development of fighter aircraft and missiles because a greater number of candidate vehicle configurations could be considered and their performance evaluated, thus reducing the cost and time required in the design cycle.

## Approach

The approach taken is to solve the three-dimensional Maxwell equations employing a mature computational fluid dynamics technology. Specifically, a compact higher-order finite-volume time-domain/frequency-domain method is used to compute the EM field about scattering bodies.

## Accomplishment Description

The two-dimensional EM-scattering code MDRCS2D was extended to calculate the scattering from dielectric objects and was extended to three dimensions. Especially noteworthy are the trailing edge and transverse magnetic scattering calculations from an airfoil, an ogive, a slit, and the EM-scattering from a perfectly conducting sphere.

## Significance

The proposed project represents the development of leading-edge technology in computational EM and will have substantial impact on the development of both fighter aircraft and missile programs.

## Future Plans

To develop and validate a three-dimensional Maxwell solver and use it to calculate the radar cross-section of complete, real-world, three-dimensional configurations.

## Publications

1. Huh, K. S.; Agarwal, R. K.; and Widnell, S. E. "Numerical Simulation of Acoustic Diffraction of Two-Dimensional Rigid Bodies in Arbitrary Flows." AIAA Paper 90-3920, 1990.
2. Huh, K. S.; Shu, M.; and Agarwal, R. K. "A Compact High-Order Finite-Volume Time-Domain/Frequency-Domain Method for Electromagnetic Scattering." AIAA Paper 92-0453, 1992.



Amplitude of magnetic induction ( $B_z$ ) of a scattered field for the trailing-edge case about the airfoil NACA0012. Red represents maximum amplitude and blue represents minimum amplitude.

# Helicopter Fuselage, Rotor, and Rotor/Body Interaction Flow-Field Calculations

Ramesh K. Agarwal, Principal Investigator  
Co-Investigator: Jerry E. Deese  
McDonnell Douglas Research Laboratories

## Research Objective

To develop computational codes capable of predicting the transonic viscous flow about helicopter fuselages, rotors, and rotor-fuselage combinations in hover and forward flight.

## Approach

For calculating turbulent flow about helicopter fuselages, the Reynolds-averaged Navier–Stokes (RNS) equations are solved in an inertial frame on a body-conforming curvilinear grid using a finite-volume Runge–Kutta time-stepping scheme. For calculating turbulent flow about rotor blades, the RNS equations are solved in a rotating coordinate system. Rotor-wake effects are modeled in the form of a correction applied to the geometric angle of attack along the blades. Two approaches are being examined for rotor/body interaction calculations. The zonal approach uses a grid fixed to the blade and a grid fixed to the fuselage with a buffer grid between that shears in time. The chimera approach uses grids fixed to and overlapping the blades and the fuselage.

## Accomplishment Description

Flow fields about the MDX fuselage in both ascending and descending flight were calculated for validation of the no-tail

rotor concept. Zonal and chimera grids have been generated for a generic rotor/body configuration. Cross-sectional planes of this grid are shown in the accompanying figures.

## Significance

Development of a code that can compute rotor/body interaction flow field will allow the designer to analyze the interference effects of the two components and optimize the configuration.

## Future Plans

The primary focus is on the calculation of rotor/body interaction flow field. Calculations will be performed on multibladed helicopter rotor/fuselage configurations and will be compared with experimental data for code validation. Calculations will then be performed on new unconventional rotorcraft configurations.

## Publication

Adams, F. P. "Decomposition Strategies for a Multi-Block Time-Dependent Grid about a Helicopter Rotor/Fuselage Configuration." Master's Thesis, Mississippi State University, Dec. 1991.

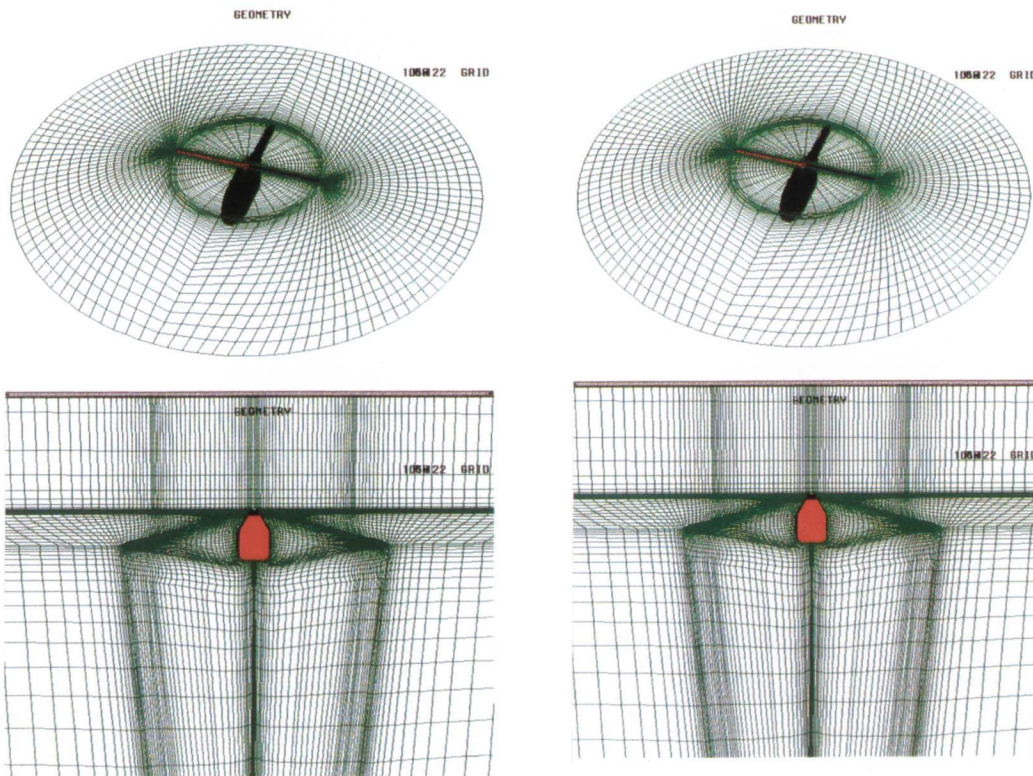

*Cross-sectional views of a zonal grid for a generic two-bladed helicopter configuration.*

# Numerical Calculation of Vortical Flows

Shreekant Agrawal, Principal Investigator  
Co-Investigator: Brian A. Robinson  
McDonnell Aircraft Company

## Research Objective

To use computational fluid dynamics (CFD) methods to accurately predict vortical flows and to develop a vortex breakdown criterion that allows rapid determination of breakdown location from a CFD solution.

## Approach

The CFL3D Euler/Navier–Stokes code based on an implicit, finite volume, upwind scheme is used to calculate vortical flows over a flat plate 70 degree delta wing at high angles of attack. Very dense grids using grid embedding are used to resolve the vortical flow features. An integral formulation of the Rossby number is employed to develop a vortex breakdown criterion for the flow about this type of wing. The CFL3D code is also used to compute initial solutions on three different tangent ogive forebodies at high angles of attack. The TLNS3D code is also used to predict the highly separated flow over a wing upper surface which results in a separation vortex.

## Accomplishment Description

The flat plate delta wing has been analyzed at  $M_\infty = 0.3$  and  $Re = 1$  million for several high angles of attack to examine leading edge vortex breakdown. An H-O grid topology (61 axial x 65 normal x 89 circumferential) with and without grid embedding has been used to examine effects of grid resolution. A vortex breakdown criterion based on the Rossby number was developed. A Rossby number of about 1.0 appears to indicate a burst vortex (shown in the figure). Mach number effects and solution instability were also investigated using the Rossby number. Each solution required about 10 Cray-2 hours and 40 megawords of central memory. Initial solutions on three tangent ogive forebodies (circular, elliptic, and chined cross sections) at high angle of attack have also been computed on sequenced grids. These initial solutions required about 2 Cray-2 hours and 16 megawords of memory. Large scale separation and a separation vortex have been computed on a wing–fuselage geometry. This case required 10 Cray-2 hours and 95 megawords of memory.

## Significance

The Rossby-number vortex breakdown criterion identifies burst location as the CFD code is running, easing the burden on the aircraft designer to perform time consuming postprocessing to obtain the same information. As a result of the identification of the separation vortex from the highly separated wing, fences are being investigated as a potential fix.

## Future Plans

The Rossby-number vortex breakdown criterion will be applied to more complex geometries at different Mach numbers. Fine grid solutions will be obtained on the tangent ogive forebodies and solutions will be compared to wind tunnel data. Surface blowing will be investigated as a vortex control mechanism on a chined forebody configuration.

## Publications

1. Agrawal, S.; Barnett, R. M.; and Robinson, B. A. "Numerical Investigation of Vortex Breakdown on a Delta Wing." *AIAA Journal* 30 (Mar. 1992): 584–591.
2. Agrawal, S.; Robinson, B. A.; and Barnett, R. M. "Prediction of Vortex Breakdown on a Delta Wing." Presented at the Fifth Symposium on Numerical and Physical Aspects of Aerodynamic Flows, Long Beach, CA, Jan. 1992.
3. Robinson, B. A.; Barnett, R. M.; and Agrawal, S. "A Simple Numerical Criterion for Vortex Breakdown." AIAA Paper 92-0057, Jan. 1992.

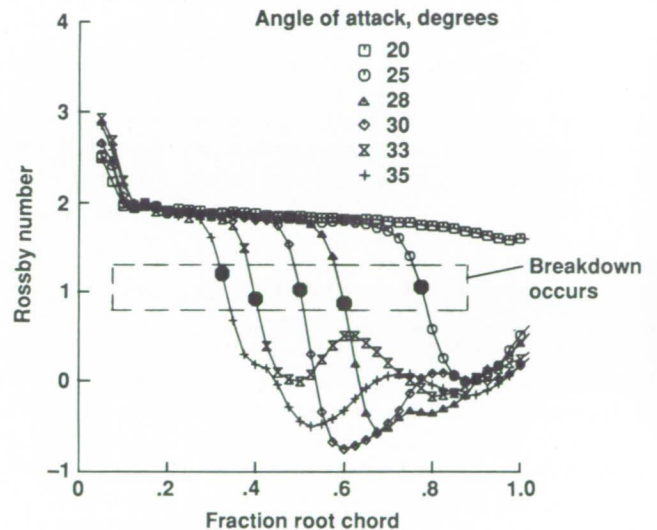

Resolving vortical flows and locating burst using the Rossby number; 70 degree delta wing,  $M_\infty = 0.3$ ,  $Re = 1 \times 10^6$ , CFL3D laminar solutions. The Rossby number locates the vortex burst.

# Transonic Reynolds Number Effects on Aircraft Configurations

Jassim A. Al-Saadi, Principal Investigator

Co-Investigators: Richard A. Wahls, William K. Londenberg, and Melissa B. Rivers

NASA Langley Research Center/ViGYAN, Inc.

## Research Objective

To predict Reynolds number effects on complex aircraft configurations at transonic and subsonic speeds through the application of computational fluid dynamics (CFD) techniques.

## Approach

Various aircraft configurations are examined using established CFD codes. The aircraft under consideration correspond to models tested in the National Transonic Facility (NTF) under current research programs. The use of various CFD codes allows assessment of viscous modeling capabilities as well as the ability to treat complex aircraft geometries.

## Accomplishment Description

Three-dimensional compressible Navier–Stokes solutions for the forebody of the X-29 research aircraft, including the nose boom and canopy, have been obtained for the flight Reynolds number at angles of attack of 30 and 40 degrees. The calculations are performed using the CFL3D code, with a typical solution requiring 18 megawords of memory and 6 Cray-2 hours. Comparison with experimental data is awaiting NTF testing. Three-dimensional wing/fuselage solutions for an advanced high-wing transport have been obtained using the unstructured-grid Euler code USM3D. A typical solution requires 32 megawords of memory and 8.5 Cray-2 hours. Comparison is being made with existing NTF force and pressure data. The agreement with measured wing pressure coefficients is typical of inviscid calculations.

## Significance

This research is part of the ongoing Reynolds-number scaling program. The use of Navier–Stokes codes is necessary for investigating the effects of the Reynolds number, while the treatment of complex geometries is simplified through use of unstructured-grid codes, which are currently Euler methods. The current approach allows code selection to be tailored to the given problem while providing a base of experience with such codes. The results obtained will help lead toward reliable prediction of Reynolds number effects and indicate the strengths and weaknesses of current CFD codes in such applications.

## Future Plans

The USM3D code will be used to analyze a transport configuration that includes underwing engine nacelles. Existing Navier–Stokes codes will be used to analyze High-Speed Civil Transport configurations at subsonic and transonic speeds.

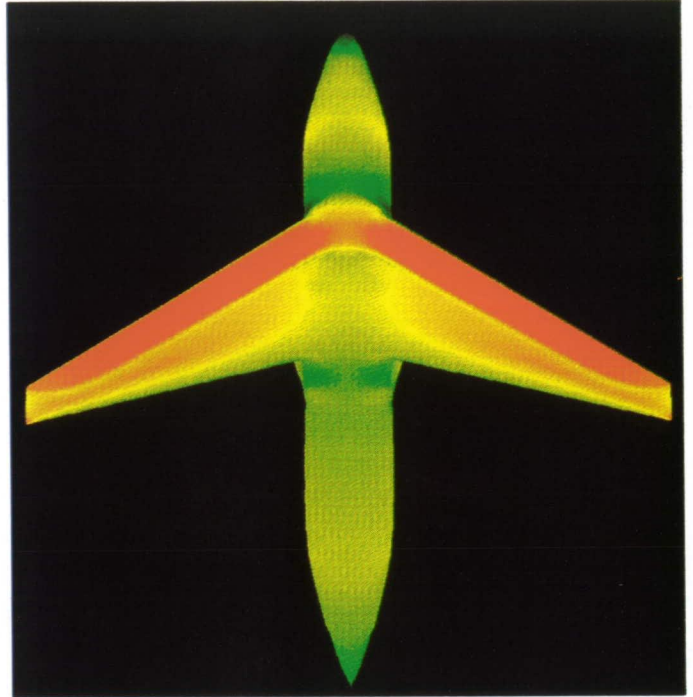

*Upper surface pressure contours from an unstructured-grid Euler calculation of a high-wing transport wing/fuselage configuration at transonic cruise conditions.*

# Hydrodynamic Ram Structural Response Analyses

K. Appa, Principal Investigator  
Co-Investigator: Wendy S. Pi  
Northrop Corporation

## Research Objective

To predict the hydrodynamic ram pressures and the structural responses of fuel tanks subjected to ballistic threats based on computational fluid dynamics (CFD) methods.

## Approach

The computational scheme employs finite-element methods for representing the fluid domain as well as the fuel-cell structures. Euler equations with numerical damping are used to describe the motion of the fluid due to impacts and traversal of the fuel cells by the projectiles.

## Accomplishment Description

The finite-element based CFD code for hydrodynamic ram analysis was numerically exercised for two one-dimensional unsteady-gas dynamics problems: (1) the Riemann problem (a long shock tube separating two initial gas states) which simultaneously contains a shock wave, a contact discontinuity, and an expansion fan, and (2) the problem of two interacting blast waves which involve multiple interactions of strong shocks and rarefactions and with contact discontinuities. The computed flow quantities compare very well with the theoretical results for both cases. The average job run for the test cases needed only a minimal amount of memory and Cray hours.

## Significance

The ability to predict the hydrodynamic ram pressures and the accompanying structural response of fuel tank panels is of great importance in designing aircraft for survivability against ballistic threats. There is no generally accepted and validated method by the United States aircraft survivability/vulnerability community to predict hydrodynamic ram pressures generated by highly explosive projectiles that detonate in the fuel, the liquid/structure interaction, and the structural response of the fuel tank.

## Future Plans

The current code will be developed to include a dynamic model for a high velocity projectile traversing the fuel tank.

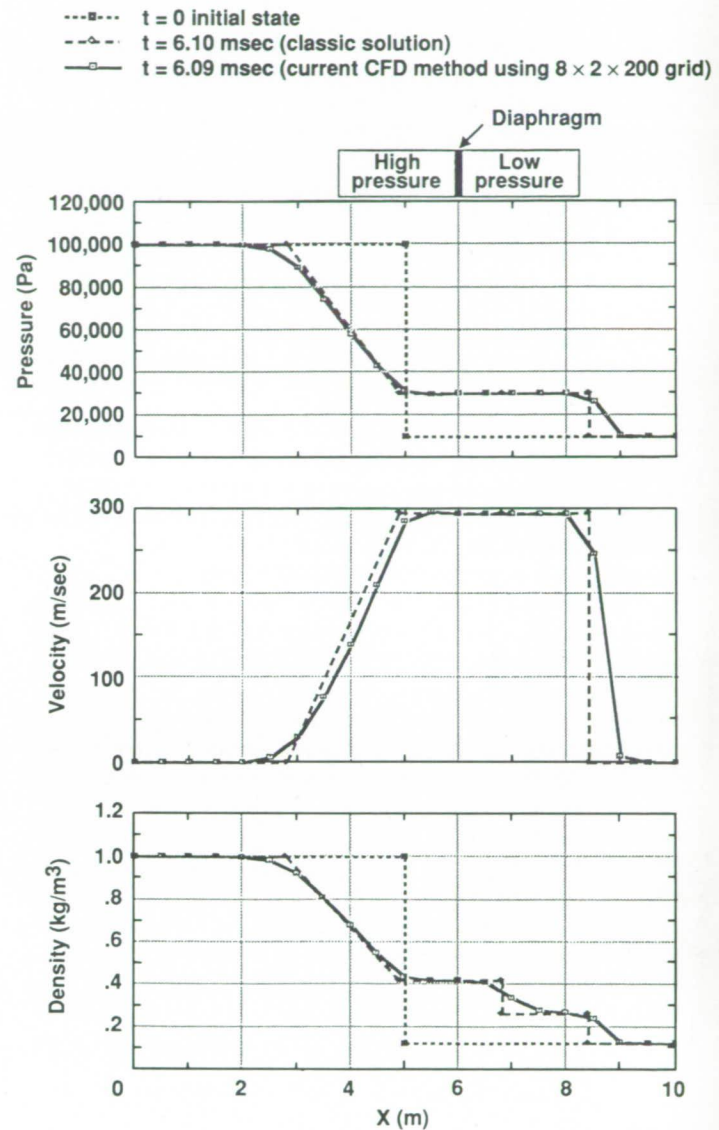

Correlation of flow quantities in a shock tube (Riemann problem).

# Nonlinear Baroclinic Instability

Jeffrey R. Barnes, Principal Investigator  
Co-Investigator: Richard E. Young  
Oregon State University/NASA Ames Research Center

## Research Objective

To investigate nonlinear baroclinic instability and transient baroclinic eddies in the atmospheres of Earth and Mars through numerical simulation.

## Approach

A three-dimensional, spectral, primitive-equation model of atmospheric circulation is employed to simulate the nonlinear development and evolution of transient baroclinic eddies. This model offers computational efficiency through a semi-implicit time scheme, high spatial resolution, considerable flexibility in configuration, and on-line energy diagnostics.

## Accomplishment Description

A study of the influence of thermal damping and surface drag on the nonlinear evolution of baroclinic eddies in Earth's atmosphere was completed with the performance of a final set of simulations and the computation of model diagnostics. The Earth simulations, typically requiring about 1–2 Cray Y-MP hours and 10 megawords of memory, examined the fundamental roles of thermal damping and surface drag in the evolution of baroclinic eddies beyond an initial life cycle of growth and decay. These experiments demonstrated the crucial importance of surface drag for the eddy development through its effect on the mean circulation. The experiments also revealed novel aspects of wave/mean-flow interaction associated with a critical surface in the subtropical upper troposphere. A circulation model suitable for simulations of the Martian atmosphere was developed and tested in several initial experiments. It offers very high vertical resolution (the model top is 80 km altitude) and high spatial resolution and demands about 5–10 Cray Y-MP hours and 20 megawords of memory per simulation. An important part of the Mars model development effort was devoted to the creation of a realistic global basic state. The initial numerical experiments were to determine the optimal values for the internal model diffusion and to examine the effect of the model's upper boundary.

## Significance

Transient baroclinic eddies are important for the Earth's atmospheric circulation in middle latitudes. Cyclonic weather systems are manifestations of these eddies and transport large amounts of heat poleward. Because of this transport, baroclinic eddies are key players in the global climate system. Major NASA programs are directed at an enhanced understanding of the climate system. Spacecraft observations show that transient baroclinic eddies

are present in the atmosphere of Mars, and observations and modeling demonstrate that they are of considerable importance for the atmospheric circulation and the Mars climate system. The transient baroclinic eddies in the terrestrial and Martian atmospheres are fundamentally similar and constitute two "laboratories" in which to investigate the basic dynamics of eddies.

## Future Plans

Simulations of nonlinear baroclinic instability in the Martian atmosphere will be performed to investigate the role of strong thermal damping in eddy evolution and scale selection, effects of large topography, and the influence of basic-state structure on eddy dynamics. Simulations of Earth's atmosphere will also be conducted to examine the manner in which baroclinic eddies act to regulate the equator-to-pole temperature gradient through their heat and momentum transports.

## Publication

Barnes, J. R. and Young, R. E. "Nonlinear Baroclinic Instability on the Sphere: Multiple Life Cycles with Surface Drag and Thermal Damping." *J. Atmos. Sci.* (May 15, 1992).

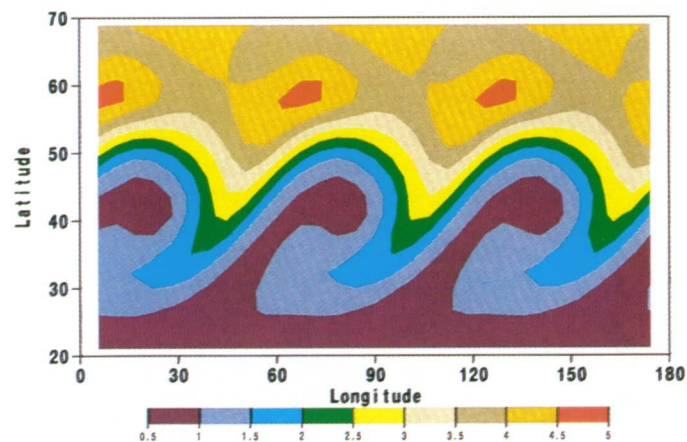

*Isentropic potential vorticity at a level near the tropopause in a simulation of nonlinear baroclinic instability in Earth's atmosphere. Red/blue colors denote high/low values of this conserved dynamical quantity, evidencing "wrapping up" and mixing processes both poleward and equatorward of the midlatitude jetstream.*

# Euler Flutter Analysis of a Complex Aircraft Configuration

John T. Batina, Principal Investigator  
Co-Investigator: Russ D. Rausch  
NASA Langley Research Center/Purdue University

## Research Objective

To demonstrate a time-marching aeroelastic analysis procedure for complex aircraft configurations.

## Approach

Modifications were made to a three-dimensional, upwind-type Euler code that used unstructured grids of tetrahedra, including the structural equations of motion for their simultaneous time-integration with governing fluid-flow equations. A novel aspect of this capability is that the solution is obtained using an unstructured grid made up of tetrahedra. The code also includes a deforming mesh algorithm capable of treating general aeroelastic motions of complete aircraft configurations.

## Accomplishment Description

A calculation was performed for a supersonic transport configuration at a free-stream Mach number ( $M_\infty$ ) of 0.907 and at 0 degrees angle of attack. The configuration consists of a rigid fuselage and a flexible clipped delta wing with two identical slender under-wing bodies to simulate engine nacelles. The bottom and side views of the surface mesh are shown in the accompanying figure and show that cells have been clustered near the wing tip and around the simulated nacelles. The complete mesh for the configuration contains 323,818 tetrahedra and 59,429 nodes. An aeroelastic time-marching calculation

was performed at a value of dynamic pressure ( $q$ ) that was found experimentally to correspond to flutter. The generalized displacements for the first three structural modes are shown in the figure. The near-neutrally stable transient of the first generalized displacement indicates that the computed aeroelastic transient is near the flutter point. Therefore, the computed value of dynamic pressure at flutter is in good agreement with the experimental value.

## Significance

The result is believed to be the first three-dimensional flutter calculation obtained using the unstructured-grid methodology for a complex aircraft configuration.

## Future Plans

To continue the development of a highly accurate and efficient solution algorithm for the Euler and Navier–Stokes equations for aeroelastic analysis of complex aircraft configurations, and to perform additional calculations to further validate the method.

## Publication

Rausch, R. D.; Batina, J. T.; and Yang, H. T. Y. "Three-Dimensional Time-Marching Aeroelastic Analyses using an Unstructured-Grid Euler Method." AIAA Paper 92-2506, Apr. 1992.

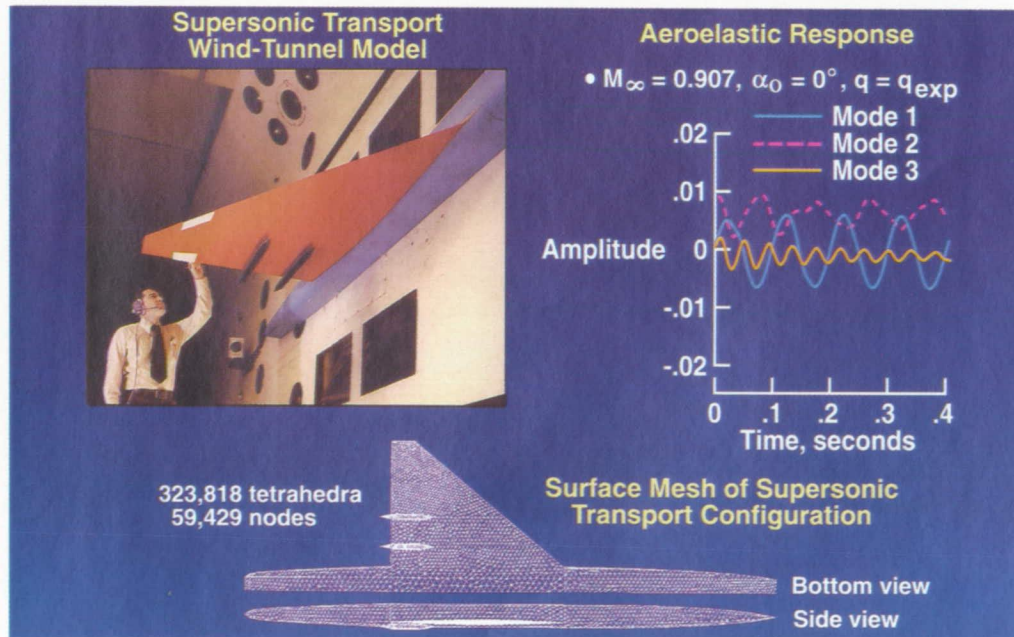

Euler flutter analysis of a complex aircraft configuration using unstructured-grid methodology.

# Aerodynamic Shape Optimization

Oktay Baysal, Principal Investigator

Co-Investigators: Mohamed E. Eleshaky and Greg W. Burgreen  
Old Dominion University

## Research Objective

To develop a new aerodynamic shape method to optimize the nozzle of the National Aero-Space Plane (NASP) and to optimize the control surfaces and propulsion integration of the High-Speed Civil Transport (HSCT).

## Approach

A computational fluid dynamics (CFD) algorithm and an optimization algorithm are directly coupled by using a discrete sensitivity analysis methodology. The optimizer is used to determine the shape. To avoid restricting the shape to any class of surfaces, the aerodynamic shape is defined by the computational surface grid. The flow-field solution is obtained by a CFD analysis method when significant shape changes are made during the evolution toward the optimum shape. A flow-field extrapolation method called flow prediction is used when the shape changes are small.

## Accomplishment Description

The optimization method is implemented in a new computer program known as Aerodynamic Design Optimization using Sensitivity (ADOS) analysis. The ramp shape of the NASP nozzle was optimized for maximum axial thrust coefficient. Starting from three completely different and arbitrary initial shapes, identical optimum nozzle shapes were obtained resulting in significant increases (up to 50%) of wall shape dependent thrust components. The ADOS code required 3.5 Cray Y-MP hours in each of these cases and used 18 megawords of memory. In order to account for viscous effects, the shape optimization methodol-

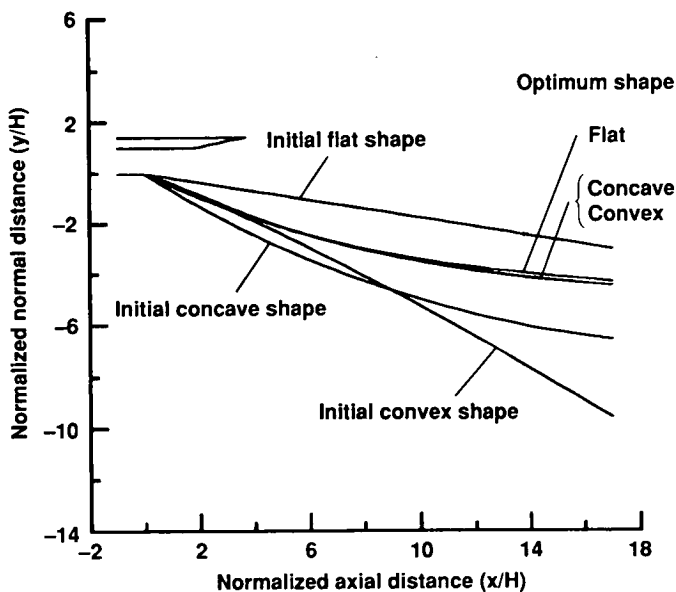

Comparison of the final nozzle ramp shapes.

ogy was extended to the thin-layer Navier–Stokes equations. The method was then proven by successfully optimizing the shape of a transonic airfoil at 0 degree angle of attack to achieve a minimum drag while obtaining a lift above a specified value. This required 7 Cray Y-MP hours and used 35 megawords of memory.

## Significance

The methodology contributes to state-of-the-art aerodynamic design optimization and will be directly applied to the design of the HSCT.

## Future Plans

The two-dimensional sensitivity analysis computer program will be improved to reduce memory requirements and then will be expanded to three dimensions. The shape optimization methodology will be extended to handle complex geometries through domain decomposition procedures. The overall optimization method will be applied to the design of HSCT control surfaces.

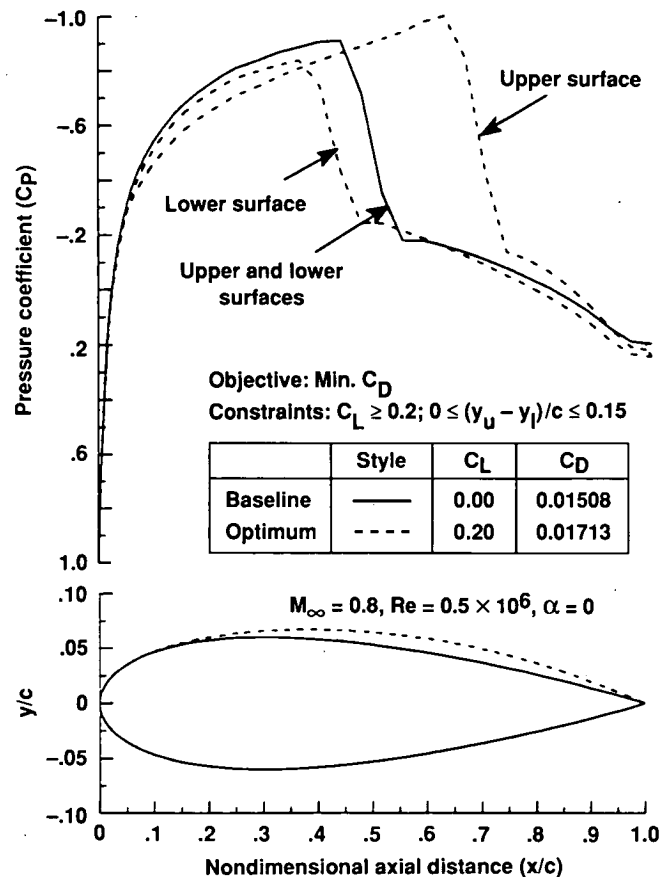

Airfoil shape and distribution of surface pressure coefficients.

# Turbulent Boundary Layer with Heat Transfer

Diane M. Bell, Principal Investigator  
Stanford University

## Research Objective

To construct data bases for the heated turbulent boundary layer in an unperturbed environment and in the presence of free-stream turbulence (FST). The data bases will be used to (1) quantify the poorly understood scalar transport mechanisms, (2) determine how FST interacts with the momentum and thermal boundary layers, and (3) improve existing turbulence models.

## Approach

Direct numerical simulations (DNS) of the unsteady three-dimensional incompressible Navier–Stokes equations are used to compute spatially developing turbulent flat-plate boundary layers with an arbitrary number of passive scalars. The fully spectral code uses no turbulence models.

## Accomplishment Description

This simulation has a momentum thickness Reynolds number range of 300–700, scalar solutions for Prandtl numbers of 0.1, 0.71, and 2.0, and an unperturbed free stream. The previously computed statistically stationary coarse-grid ( $256 \times 55 \times 96$ ) solution was stabilized on two intermediate meshes ( $384 \times 61 \times 160$  and  $600 \times 65 \times 216$ ) and on the fully resolved fine grid ( $720 \times 70 \times 256$ ). This required 85, 150 and 250 single-processor CPU hours respectively. Approximately 10% of the fine-grid statistical sample was also collected. Since a fine-grid sample spanning three eddy turnover times requires approximately 350 CPU hours, the cost of the entire simulation is estimated at 1,000 CPU hours. The memory requirements for the three grids range from 4–12 megawords, with 35–60 megawords of solid-state storage-device memory. In general, the preliminary results agree well with experiment and boundary-layer theory. However, inner wall scaling of the mean profiles suggest different functional forms of Coles' low-Reynolds-number corrected hydrodynamic wake parameter and of the thermal wake term. Also, as shown in the first figure, the normal turbulence flux differs significantly from wind tunnel data. The similarity of the computed normal flux in air and the Reynolds stress is consistent with the similarity of their respective correlation coefficients and with the similarity of the axial momentum and thermal intensities. Since these turbulence quantities also compare well with measurements, we conclude that the experimental normal turbulence flux is too low. This low flux results in an overprediction of the experimental turbulent Prandtl number. In the second figure, the steep rise of the turbulent Prandtl number predicted from experimentally derived turbulence models is not found in the boundary-layer DNS, or in Kim's channel-flow DNS.

## Significance

Turbulence models for scalar transport are only accurate for simple geometries and restricted flow parameter ranges; no existing models adequately predict the effects of FST. The DNS results provide the detailed information necessary to investigate the flow physics and to develop predictive tools.

## Future Plans

The collection of fine-grid statistical samples for the unperturbed case will be completed. Three papers are planned covering mean flow and turbulence statistics analysis, structural analysis, and turbulence modeling. The coarse-grid stabilization of two flows with FST will also be completed.

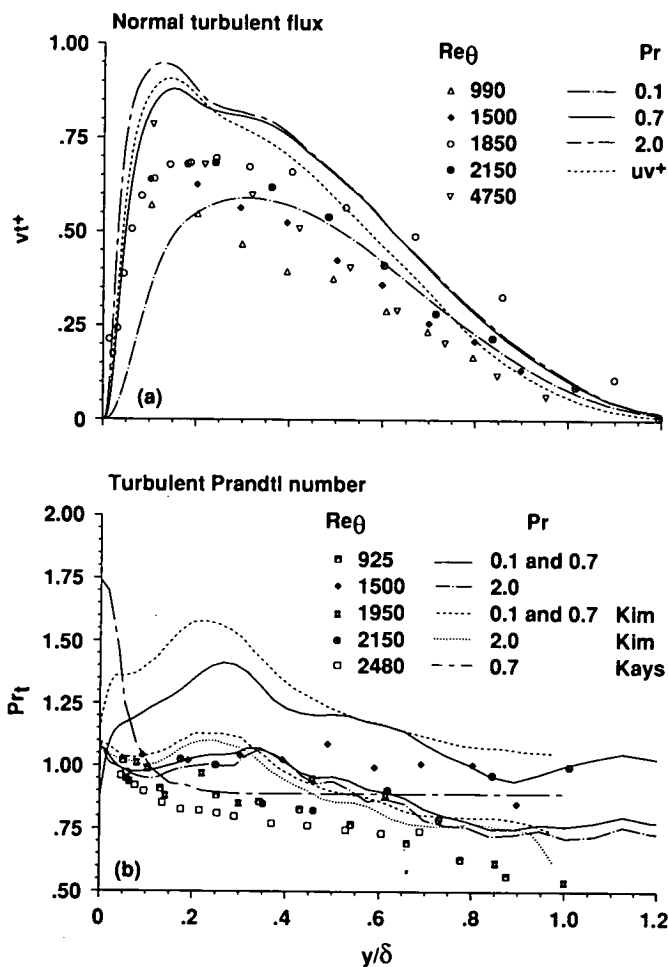

(a) Normal turbulence flux. (b) Turbulent Prandtl number.

# Three-Dimensional Exhaust-Nozzle Flow Fields for High-Speed Civil Transport

Robert F. Bergholz, Principal Investigator  
Co-Investigator: William M. Turner  
General Electric Aircraft Engines

## Research Objective

To support the large-scale, three-dimensional aerodynamic design of advanced High-Speed Civil Transport (HSCT) exhaust systems with acoustic suppression. The focus is on the analysis of complex internal-nozzle and exhaust-plume flows for multistream ejector and fluid-shield nozzles. The technical challenge is to achieve acceptable acoustic and thrust performance in the suppressed mode. This requires a detailed understanding of the dominant flow features (such as shocks, viscous mixing, and separation) for various classes of nozzles.

## Approach

Currently available three-dimensional viscous-flow solvers (PAB3D, CFL3D, PARC3D) are being applied in the analysis of full scale HSCT exhaust-nozzle designs and in validation studies using recently acquired subscale model test data. Candidate nozzle designs have both two-dimensional convergent-divergent (2DCD) and axisymmetric configurations, and may incorporate lobed suppressor elements, acoustic liners, flow splitters, or dual-stream fluid shields. Computational fluid dynamics (CFD) analyses are being performed to study the aerodynamics of mixer lobe geometry, secondary flow pumping, three-dimensional internal-mixing behavior, exhaust-plume decay, and nozzle performance loss mechanisms.

## Accomplishment Description

The PAB3D code, with a high-Reynolds-number two-equation turbulence model, was applied in a large scale validation study of a 2DCD suppressor/ejector nozzle. The analysis was made for a nozzle pressure ratio of 4.0, an ejector mixing section area ratio of 1.2, and a tunnel free-stream Mach number of 0.27. The multiblock grid consisted of 1 zone/1 block in the primary core (196,725 points) and 6 zones/12 blocks (1,136,995 points) in the secondary inlet and mixing section. The first cycle of calculations required approximately 18 megawords of memory and 65 Cray-2 hours. The two accompanying figures show the flow field in a central vertical plane through the supersonic primary core and in successive cross-stream planes through the mixing section. Notable flow-field features are the internal supersonic expansion, the recompression shock and boundary-layer interaction near the nozzle exit, and the downstream development of the vortical mixing pattern.

## Significance

The HSCT exhaust-nozzle project made a significant impact on understanding the internal shock structure and three-dimensional mixing behavior of high-flow ejector nozzles under static and flight conditions. CFD analysis tools have been successfully applied in the generation of complex three-dimensional lobed mixer shapes now undergoing wind tunnel testing.

## Future Plans

Further validation studies of 2DCD ejector nozzles and more recent fluid-shield nozzles are planned. Three-dimensional

exhaust-plume analyses will be conducted and the results compared to hot-flow exhaust-plume laser-velocimetry data. Preliminary aero-design studies of new nozzle concepts are under way.

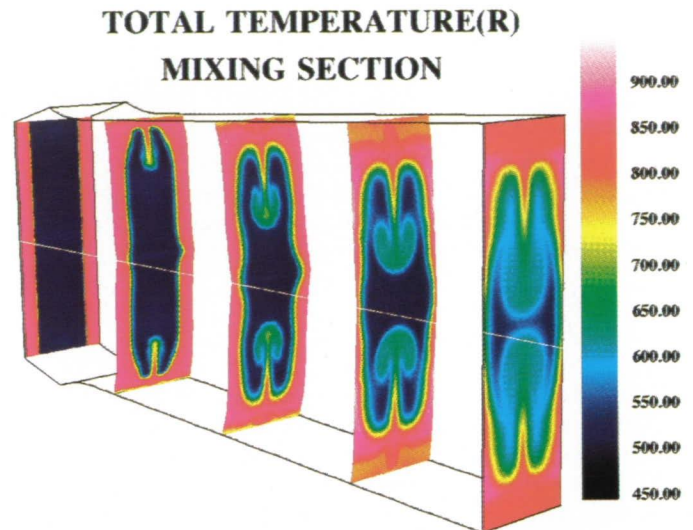

(a)

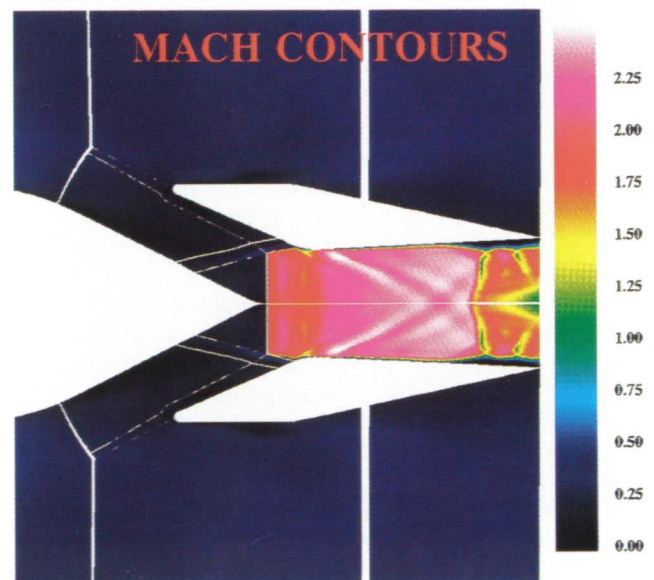

(b)

*Two-dimensional convergent-divergent ejector/suppressor exhaust nozzle. (a) Core primary nozzle—vertical centerplane. (b) Mixing section—axial planes.*

# Electromagnetic Scattering from Large Three-Dimensional Targets

Marek K. Bleszynski, Principal Investigator  
Rockwell International Science Center

## Research Objective

To extend and validate computational capabilities of the adaptive integral method (AIM) code based on a numerical solution of Maxwell's equations in the integral form.

## Approach

The AIM solver designed for large-scale three-dimensional electromagnetic computations was developed at Rockwell International during the last two years. The code incorporates modeling of general radar absorbing materials and structures encountered in actual aircraft design. The AIM solver is characterized by an approximately linear increase of memory and computational time with the number of computational elements ( $N$ ). The order of  $N$  ( $O(N)$ ) performance is achieved with a combination of iterative solution, fast multilevel convolution algorithm, and elements of spectral technique enhanced by locally applied conventional method of moments.

## Accomplishment Description

Approximately 20 hours were used to carry out validation of the new elements of the code involving local boundary conforming corrections to the spectral technique and new multitasking algorithms for fast Fourier transforms. Another 80 hours were spent on applications to actual targets of interest in aircraft design. Each calculation took 90 Cray Y-MP seconds using a single processor.

## Future Plans

An automatic generation of a periodic uniform grid in the object's interior and a locally deformed grid at its boundaries and at material interfaces will be developed, implemented, and validated. Subsequently, an extensive and versatile set of new basis functions, which will improve the accuracy and extend the applicability of the method to a wider frequency range, will be used. Calculations involving a full aircraft will be attempted. Utilizing the AIM code optimization capabilities, a variety of optimization problems involving leading- and trailing-edge design and surface wave propagation will be carried out.

## Significance

The ability to predict electromagnetic scattering and radiation of large three-dimensional structures is of considerable practical importance in aircraft design and biomedical applications. Computations based on the AIM code facilitate the task of finding the optimal target parameters which lead to desired electromagnetic signatures.

## Publication

Bleszynski, M. and Jaroszewicz, T. "A New  $O(N)$  Integral Equation Solver for Large-Scale Electromagnetic Computations." 1992 URSI Conference. Boulder, CO, 1992.

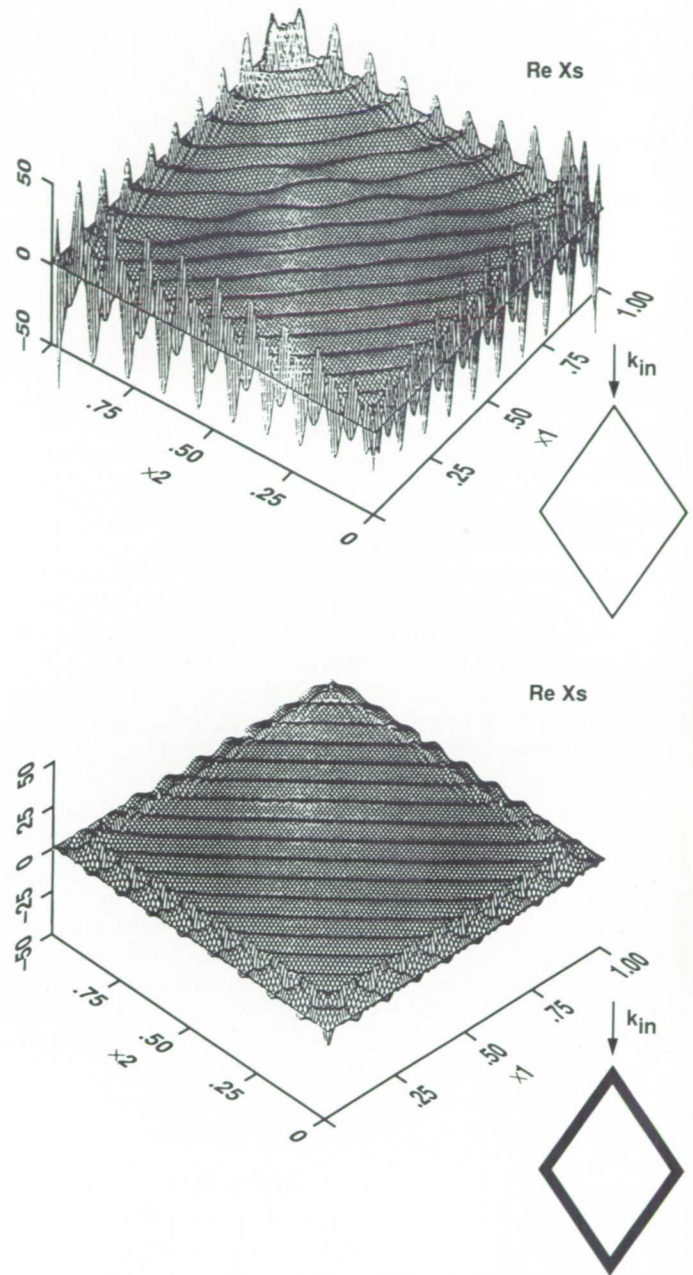

Distribution of the real part of the current component along the polarization vector of the incident wave on a rhomboidal  $5.5\lambda \times 17.5\lambda$  (a) perfectly conducting plate and (b) perfectly conducting plate with resistive edges, illuminated by a grazing, transverse magnetic polarized plane wave. The axes of the reference system  $x_1, x_2$  are taken along the plate sides.

# Short Takeoff and Vertical Landing Aircraft Thermal/Acoustic Loads

William W. Bower, Principal Investigator

Co-Investigator: Robert E. Childs

McDonnell Douglas Research Laboratories/Nielsen Engineering and Research, Inc.

## Research Objective

To predict the dynamic behavior and thermal/acoustic loads associated with single and multiple supersonic impinging jets.

## Approach

The calculations of unsteady flows are based on large-eddy simulation. With this approach, the mean flow plus the dominant turbulent and acoustic modes are resolved and the small-scale turbulence that cannot be resolved is modeled. The simulations are based on the compressible Navier–Stokes equations with a simple subgrid-scale turbulence model, which are solved with explicit Runge–Kutta time integration coupled with fourth-order finite-volume discretization. Nonlinear artificial dissipation is used to capture shocks. Characteristic nonreflecting boundary conditions are employed to pass acoustic and vortical modes out of the computational domain.

## Accomplishment Description

The goal was to extend the axisymmetric supersonic free and impinging jet flow analysis to three dimensions. A preliminary simulation has been run for a jet issuing from a round nozzle with choked flow at a nozzle pressure ratio of 1,265, static temperature ratio of 0.833, expanded-jet Mach number of 1.19, and Reynolds number of 50,000. The jet's dynamical structure up to five nozzle diameters is depicted in the accompanying figure for a dimensionless time of 170 based on the nozzle radius and acoustic speed. The contours of static pressure referenced to the free-stream value are given on the midplane of the jet as viewed from the side. The slightly subambient pressure regions highlight the low-pressure zones associated with the vortex cores. The structures are clearly not axisymmetric and appear to be helical based on an evaluation of sequential plots through the jet. This computation required approximately 14 Cray Y-MP hours and 11 megawords of memory for a grid containing 59 points in each coordinate direction. It is important to remember that this is a preliminary result on a coarse grid in a small computational domain. Some noise reflection/generation at outflow boundaries and truncation errors certainly effect the computed solution.

## Significance

A vertical takeoff and landing (VTOL) aircraft hovering on the thrust of jet-engine exhaust in close proximity to the ground can experience very high levels of acoustic and turbulent pressure fluctuations. The pressure fluctuations combined with elevated temperatures from the jet engine exhaust pose structural fatigue problems. The physical processes occurring in hot impinging jets that produce these loads are very complex. Interactions among turbulence, the shock structure of the exhaust jets, and the ground give rise to acoustic levels high enough to accentuate the jet turbulence. Phase locking and feedback occur, which may produce high sound-pressure levels at discrete frequencies. The present work uses simulations to provide more insight into processes relevant to VTOL aircraft ground effects.

## Future Plans

The simulations will be extended to three-dimensional round and non-round impinging jets, and comparisons of the predicted flow and acoustic fields will be compared with experimental data.

## Publication

Wlezien, R. W.; Bower, W. W.; Childs, R. E.; Howe, M. S.; and Kibens, V. "Experimental and Computational Investigation of Supersonic STOVL Jet Flow and Acoustic Fields." NASA CR-189547, Jan. 1992.

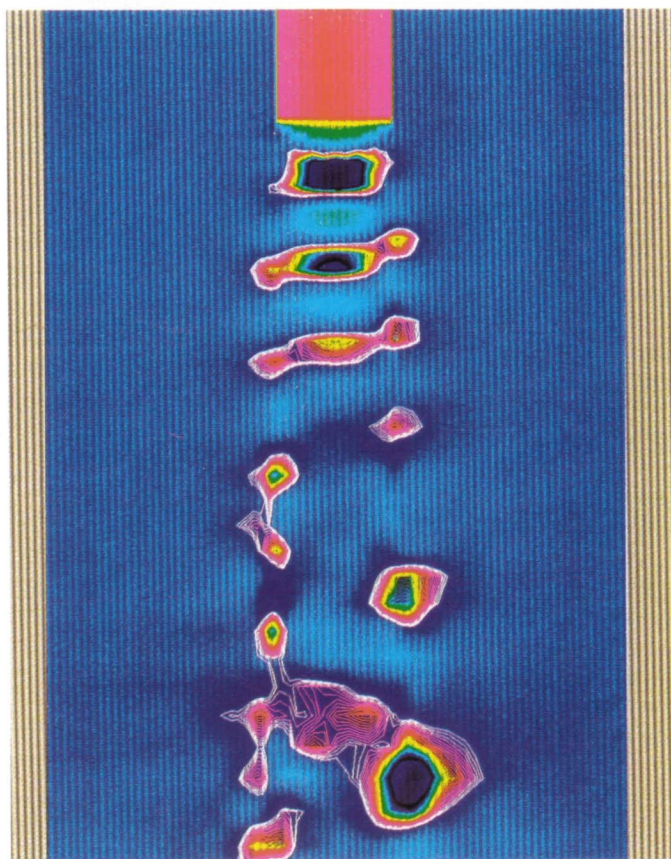

*Contours of static pressure referenced to the free-stream value at the midplane of the jet as viewed from the side. Inside the highlighted regions bounded by the white boundary lines, the high value is white, 0.98, and the low value is black, 0.90. For the field outside the white boundary lines, the scale changes and the dark blue corresponds to a normalized pressure of unity.*

# Local Passive Scalar Dispersion in a Turbulent Boundary Layer

James G. Brasseur, Principal Investigator

Co-Investigators: P. K. Yeung, Samir Khanna, and Brian P. Moquin  
Pennsylvania State University/Georgia Institute of Technology

## Research Objective

To analyze the structural interrelationships among passive scalar and hydrodynamic field structure during transport of passive scalar within wall-bounded flows and the interpretation of hydrodynamic field dynamics in terms of concentration field dynamics.

## Approach

Spalart's "fringe" algorithm has been implemented for a direct simulation of a naturally growing, zero-pressure-gradient, flat-plate boundary layer with sources of passive scalar. The algorithm makes use of fringe regions at opposite streamwise extremes of the computational domain in which sinks are placed to remove momentum and passive scalar. Additions to the code include a "heated" spanwise strip at the wall and a source term in the scalar equation for the introduction of passive scalar within the computational domain. Passive scalar sources with Schmidt number 1 are placed (1) along a heated spanwise strip at the wall, (2) at the outer edge of the boundary layer, and (3) within the narrow log layer. The scalar simulations begin from a stationary hydrodynamic field on a  $720 \times 70 \times 256$  grid with momentum-thickness Reynolds numbers from 350–780 in the streamwise direction. Full field-velocity, velocity-gradient, and passive-scalar data are collected every 4 viscous time units.

## Accomplishment Description

Initial graphical analysis has confirmed most of the structural features of the vorticity and velocity fields, including high intensity sheet-like structures in the near-wall vorticity field, lower magnitude hook-shaped concentrations of vorticity rising

from the sublayer, and streaks of concentrated turbulent kinetic energy rising from the wall. We have begun analysis of the passive-scalar evolution from the heated wall strip. Regions of highest concentration, near the passive-scalar source, appear to be strongly influenced by the near-wall streaks, whereas regions of low scalar concentration (away from the wall) appear to be under the influence of more intense vorticity fluctuations. A typical job requires 4 Cray Y-MP hours and 10 megawords of memory with 60 megawords solid-state storage-device memory.

## Significance

Our goal is to answer several questions. From a fundamental point of view, what information does dye, smoke, or temperature concentration in a wall-bounded turbulent-shear flow provide about the underlying structure and dynamics of the hydrodynamic field? What local dynamical processes contribute to net scalar and momentum transport toward and away from the wall? From a modeling point of view, how are mean-flow statistics established? What local dynamical processes contribute to global statistics? From an applications point of view, in what ways can local heat transfer be modified through manipulation of local dynamics in the turbulent boundary layer?

## Future Plans

Careful analysis of the large amounts of data being collected is just beginning. Analysis will proceed at two levels, the visual and the quantitative. Much use will be made of the methodology in which intermittent regions are extracted and conditioned with different characteristics of interest in the study.

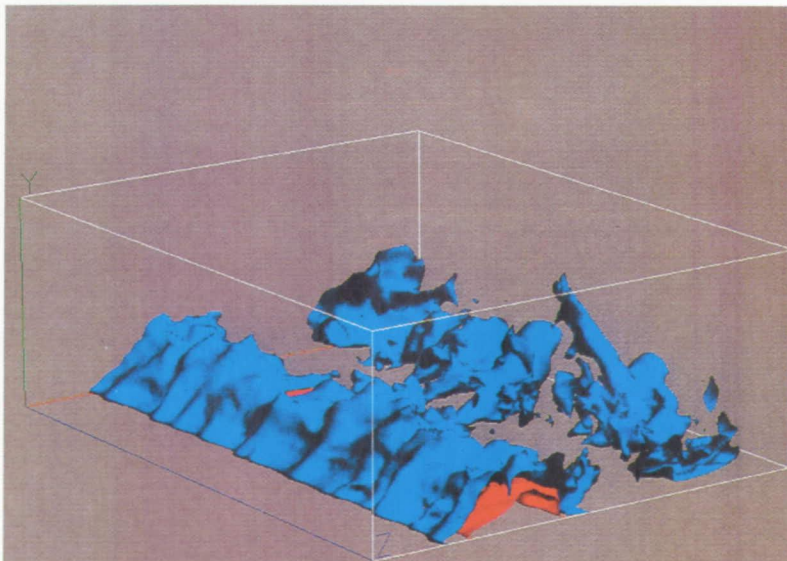

*Two isocontours of passive scalar dispersed from a "heated" spanwise strip at the wall. Streamwise, normal, and spanwise extent of the subdomain are 525, 238, and 675 wall units. High intensity scalar (red) concentration evolves to low intensity (blue) concentration over 18 viscous time units.*

# Global-Venus/Solar-Wind Interaction

Stephen H. Brecht, Principal Investigator  
Berkeley Research Associates

## Research Objective

To obtain a better understanding of how the solar wind interacts with the unmagnetized planets, Venus and Mars. Specifically, we want to understand the dynamics of the shock and magnetic barrier location as a function of solar-wind parameters and ionospheric-mass loading rate.

## Approach

We have developed a three-dimensional hybrid particle code that simulates the electrons as a fluid and the ions as individual particles. Multiple species of ions are included, as is their complete kinetic behavior.

## Accomplishment Description

The three-dimensional hybrid code HALFSHEL is running with both Navier and Reynolds codes. During the past year we simulated solar-wind flow past obstacles that are representative of Mars and Venus. These simulations included the nose region of the magnetosphere of these planets down to the terminator line. Many of the simulations were modified to include multiple-species ionospheres. We demonstrated that the presence of the ionospheric ions affects the position of the Venusian bow shock. In addition, the HALFSHEL code has shown that Mars does not form a bow shock in the subsolar region, but only on the flanks. The results have been compared to and agree with actual orbit data from Phobos-2. The simulations using HALFSHEL require approximately 40 megawords and about 32 Cray Y-MP hours. Smaller simulations are performed which only require 25–30 megawords and 10 Cray Y-MP hours.

## Significance

The results of the simulations and the visualization of the results are changing the way scientists view the interaction of the solar wind with planets such as Venus and Mars. This is particularly true of the Mars simulation results, which indicate the lack of a subsolar bow shock and are being compared with the orbital data from the Phobos-2.

## Future Plans

The HALFSHEL simulations of Mars and Venus will continue. We will investigate the role of Martian ionosphere and hot hydrogen corona on the flank shocks. Further investigation on understanding Venusian dynamics will be made this year.

## Publications

1. "Global Hybrid Simulations of Unmagnetized Planets: Comparison of Venus and Mars." *J. Geophys. Res.* 96 (1991): 11209.
2. "Three Dimensional Simulation of the Solar Wind Interaction with Mars." Submitted to *J. Geophys. Res.*, 1992.
3. "Mass Loading Effects of the Venusian Bow-Shock Location." Submitted to *Geophys. Res. Lett.*, 1992.

4. "Modeling Studies Related to Solar Interaction with Mars and Venus: A Review." Invited paper presented at General Assembly IUGG, Plasma Environments of Mars and Venus, GAM 4.7, Vienna, Austria, Aug. 1991.
5. "Hybrid Particle Simulations for Large-Scale Phenomena." Invited paper presented at General Assembly IUGG, MHD Modeling and Kinetic Simulations as Tools of Heliospheric Physics, GAM 4.3, Vienna, Austria, Aug. 1991.

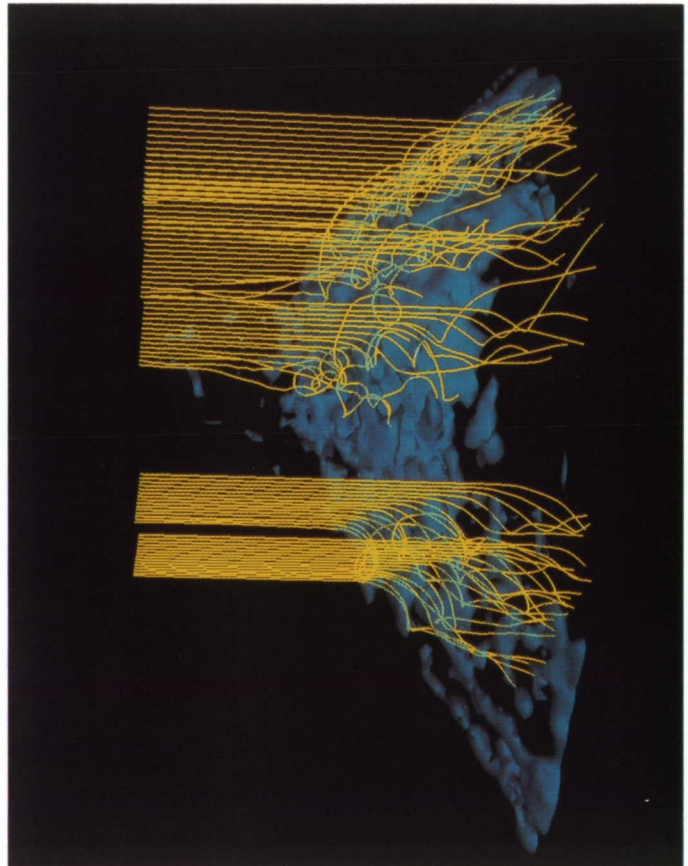

*HALFSHEL simulation of solar wind interaction with Mars. The solar wind ion trajectories are plotted. Note the structure in the magnetic field surface and the finite gyroradius behavior of the ions.*

# Hot-Gas-Manifold Flow Simulation

Richard C. Buggeln, Principal Investigator  
Co-Investigator: Sang-Keun Choi  
Scientific Research Associates, Inc.

## Research Objective

To develop a numerical simulation of the flow in a hot gas manifold pilot model for a staged combustion-cycle manifold. This problem is a complex three-dimensional flow situation requiring a full three-dimensional Navier–Stokes solution. A relatively fine grid,  $1.5 \times 10^6$  grid points, and a relatively coarse grid solution,  $0.707 \times 10^6$  grid points, are to be obtained, with the latter solution to be obtained with and without wall functions.

## Approach

The research objective is being pursued using the Scientific Research Associates, Inc., Navier–Stokes code, which solves the full Navier–Stokes equations using the Briley–McDonald alternating direction implicit approach, with the grid generated by EAGLE. With this approach, the entire domain is treated as one computational zone, thus avoiding internal zone boundaries.

## Accomplishment Description

To date, the fine grid simulation has converged. Typical runs for the fine grid simulations required 6 megawords of memory and

5,000 CPU seconds. The computational region consists of a preburner, a turbine passage, a turnaround duct, an annular duct, a transfer duct, and a main injector bowl. A velocity vector plot in the symmetry plane is shown in the accompanying figure. The asymmetry in the turnaround duct and the annular duct are evident, as is the highly three-dimensional nature of the injector bowl, which has multiple recirculation zones. The second case (the grid containing  $0.707 \times 10^6$  grid points) is well under way and approaching convergence and the third case (the wall function case) has been initiated.

## Significance

The results demonstrate the ability of Navier–Stokes solvers to simulate the highly complex viscous flows in practical flow configurations. The ongoing calculations will serve to assess grid refinement and wall function issues.

## Future Plans

The calculations will be continued and an assessment of results made.

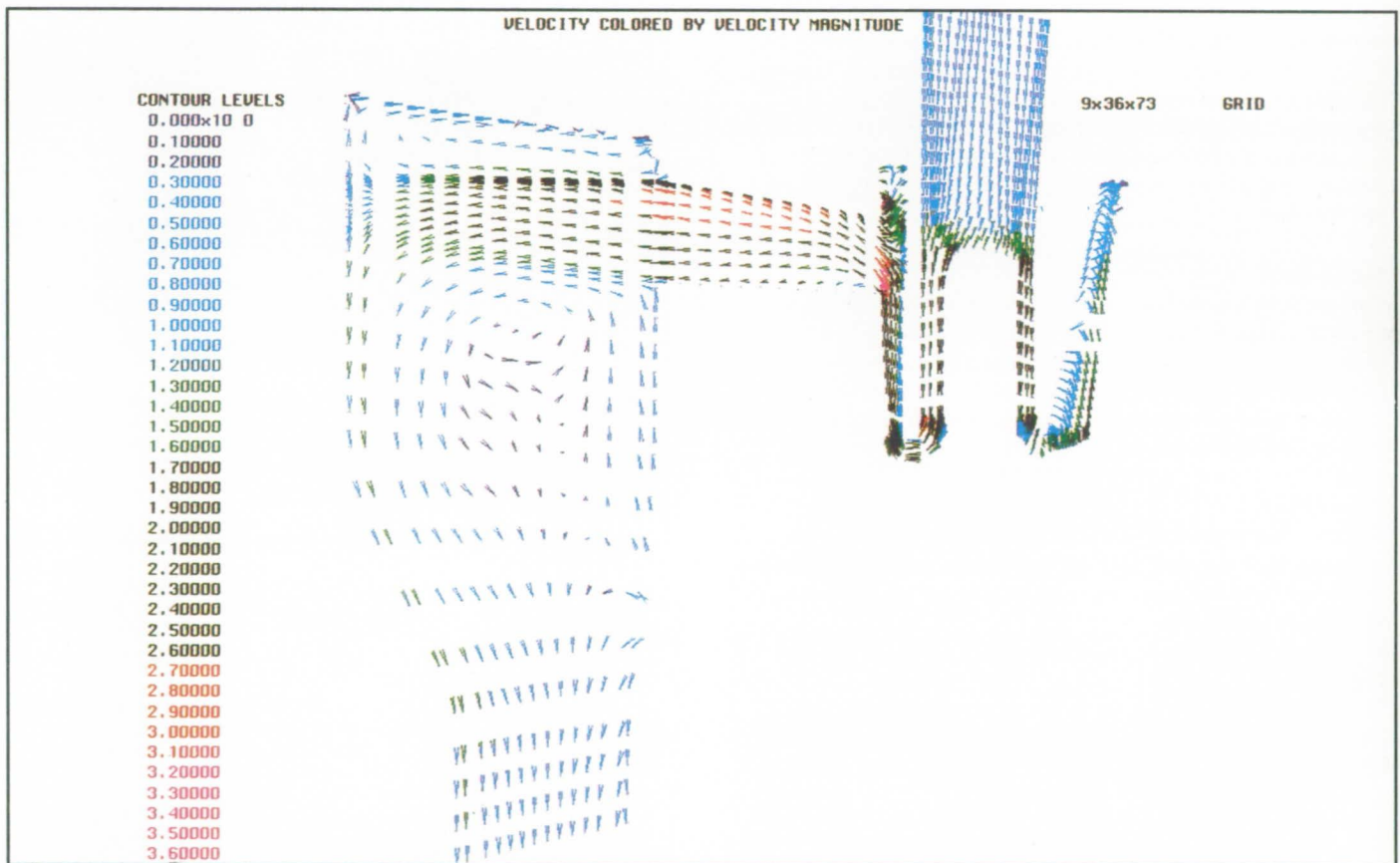

Velocity vector plot for a hot gas manifold in symmetry plane.

# Simulation and Modeling of Turbulence and Flow Acoustics

Alan B. Cain, Principal Investigator

Co-Investigators: Dennis F. Fuglsang and Nagi N. Mansour  
McDonnell Aircraft Company/NASA Ames Research Center

## Research Objective

To compute, predict, and control complex shear-layer flow phenomena (particularly flows with acoustic feedback loops).

## Approach

Finite-difference schemes are used in direct simulations of unsteady-cavity flows. To assure cost effectiveness, several schemes are evaluated analytically. It is advantageous to use grid sequencing with a one algorithm calculation. A more sophisticated scheme can be used for the final details. This work made use of the NASA Langley CFL2D code and several options in the three-dimensional MCAIR NASTD code. The final three-dimensional oblique-mode results are based on second-order upwind spatial differencing and second-order time integration.

## Accomplishment Description

Transonic cavity-flow results are in good agreement with experimental data for the surface sound pressure levels. More detailed evaluation indicates good prediction of resonant frequencies, but there is some scatter in the amplitude of the individual peaks. The results for a natural flow produce a strong harmonic response; however, a harmonic forcing of the flow at nonresonant frequencies appears to produce a very energetic and chaotic response. In addition, a natural feedback loop is identified that can result in a "self-sustaining" effect of any temporary forcing. Analysis of the evolution of the flow from an oblique-mode initial condition is in progress. A typical three-dimensional unsteady solution requires from 50–500 CPU hours and 16 megawords of memory for 662,000 cells.

## Significance

This work shows that direct simulation is a meaningful way to analyze and predict weapons-bay-cavity behavior. In a more general context, this work suggests that a priori control schemes may easily fail to achieve their desired result due to the multiplicity of solutions to nonlinear problems. The initial state of the system may determine the ultimate response.

## Future Plans

Further work is planned, including the use of higher-order schemes, the role of oblique modes (results are currently being analyzed), and the application of this research to the supersonic jet screech problem.

## Publication

Fuglsang, D. F. and Cain, A. B. "Evaluation of Shear-Layer Cavity-Resonance Mechanisms by Numerical Simulation." AIAA Paper 92-0555, Aerospace Sciences Meeting, Reno, NV, Jan. 1992.

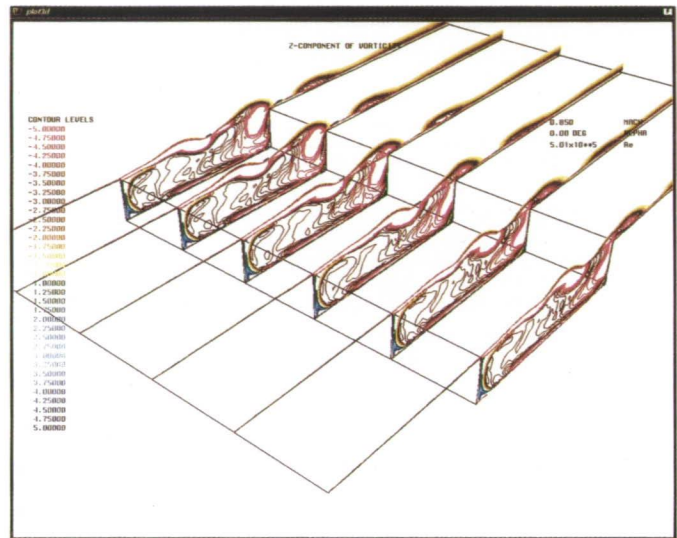

*Solution for a Mach 0.85 free-stream flow over an open cavity.*

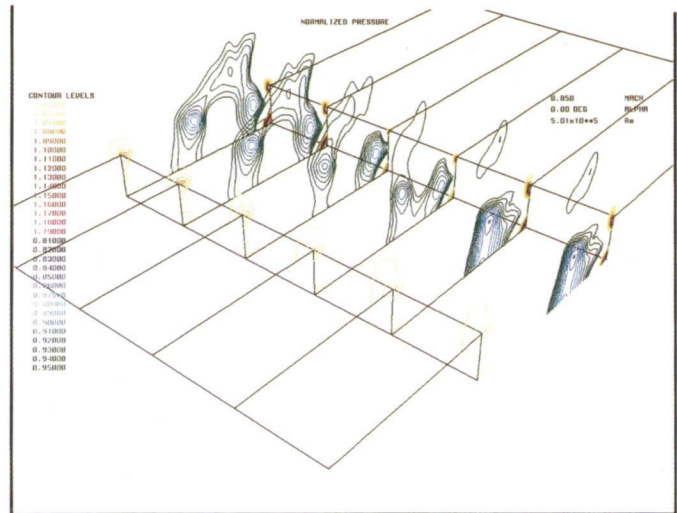

*Vorticity and pressure contours for an oblique-mode initial condition.*

# Automated Transonic Wing Design

Richard L. Campbell, Principal Investigator  
Co-Investigator: Leigh Ann Smith  
NASA Langley Research Center

## Research Objective

To create a design approach for geometrically complex configurations by combining the direct iterative surface curvature (DISC) design method with the unstructured-method three-dimensional (USM3D) Euler code.

## Approach

The DISC design method modifies the surface curvatures and slopes of an initial geometry to match target pressure distribution. This method has been successfully coupled with a number of codes, varying in complexity from small disturbance to Navier–Stokes, and has been applied to the design of aircraft components such as airfoils, wings, winglets, and nacelles. The choice of USM3D and the unstructured gridding technique, VGRID3D, allows for the study of full configurations and thus the potential to design any component in the presence of other components. Critical to this technology was the development of a dynamic mesh routine for grid perturbation based on the surface analysis technique. This allows the modifications to the surface definition computed by the design method to be easily assimilated into the surrounding grid. The spring analogy technique was modified to reduce grid distortion.

## Accomplishment Description

The DISC method was successfully coupled with the USM3D unstructured Euler flow solver to create a design tool (DUSM3D) that utilizes the advantages of unstructured grid technology. The coupling was verified by designing to known wing cross-sections for an existing transport. While this technique is currently implemented only for wing design, it has the potential for extension to all surfaces of an aircraft. For the verification

exercise, an existing generic transport configuration known as the low-wing transport was analyzed in USM3D. The resulting wing pressure distributions were used as target pressure distributions for the design. An initial configuration was created by replacing the transport's supercritical airfoils with NACA 0006 airfoil sections. The DUSM3D method was applied to the starting configuration and allowed to iterate until convergence. This particular configuration requires about 10 megawords of memory and 1.5 Cray Y-MP hours to converge (only a slight increase in CPU time over a regular analysis run). The accompanying figure shows the results of this design effort for two span stations. Pressure distributions and airfoils are shown for the original wing (target), the starting configuration (initial), and the resulting design (final). The plots show that the design method successfully reproduced the target pressures and airfoils, in spite of the large differences between the starting and target shapes.

## Significance

This exercise demonstrates the ability of the DISC design method to interact with an unstructured method and to produce verifiable wing designs. The ability to design using an unstructured method and the advantages in ease of grid development should reduce the time required to obtain advanced solutions for geometrically complex configurations.

## Future Plans

We will expand the implementation of DISC in USM3D so that wings, nacelles, winglets, and other configuration components can be easily designed. USM3D can be used to readily obtain solutions for complex geometries, and the DISC method can be used to design any surface of a given geometry.

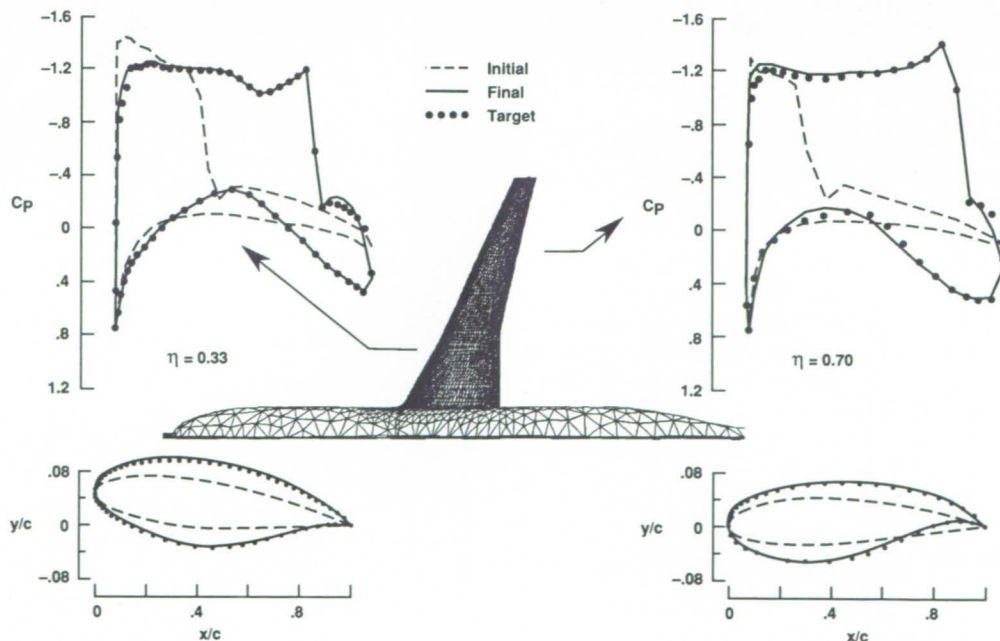

Wing-design results for low wing transport,  $M = 0.77$ .

# Simulation of a Time-Developing Incompressible Plane Wake

Brian J. Cantwell, Principal Investigator

Co-Investigators: R. Sondergaard, J. Soria, and J. H. Chen

Stanford University/Sandia National Laboratory

## Research Objective

To study the physics of fine-scale motions of turbulent-shear flows using topological methods applied to a three-dimensional direct numerical simulation of a time-developing, incompressible plane wake.

## Approach

The project consisted of two components. The first was to generate sets of moderately high Reynolds number ( $Re$ ) direct numerical simulations of a time-developing incompressible plane wake. These data sets were then studied in the space of invariants of the velocity gradient tensor using recently developed topological analysis tools. The direct numerical simulation employed a version of an existing free-shear-layer code developed by Rogers and Moser. Linear stability theory was applied to determine the unstable modes used to initiate the computations. A set of low-Reynolds-number ( $Re = 500$ ), low-resolution test runs was performed to verify the code and to pick an appropriate set of initial disturbances for the higher Reynolds number (up to  $Re = 4,000$ ) runs. The initial disturbances chosen were combinations of two-dimensional waves at the most unstable wavelength and pairs of oblique disturbances at the two-dimensional fundamental and subharmonic wavelengths. Topological analysis was performed on the data using post-processors and graphics routines we developed.

## Accomplishment Description

Four low-Reynolds-number and four higher-Reynolds-number simulations were run. A typical simulation required between 30–40 restart files. For the higher-Reynolds-number simulations, each restart file required approximately 4 Cray Y-MP hours and 20 megawords of memory. Topological analysis of the fine scales, which is still in progress, has revealed similarities with flows previously studied. For regions of high dissipation rates, the rate of strain has an unstable-node/saddle/saddle-type topology (two positive and one negative principal strain rate), the entropy has a magnitude comparable to that of the dissipation rate, and the vorticity vector tends to align with the intermediate principal rate-of-strain direction.

## Significance

This project enhances our understanding of the basic properties of turbulent motion. Better understanding of the physics of the fine-scale structures is needed to develop improved subgrid scale turbulence models that will enhance our ability to solve technical problems involving turbulent flow.

## Future Plans

We will (1) modify the simulation code to run on one of the new massively parallel computers now available, allowing us to run simulations at a higher Reynolds number than on the Cray Y-MP

and (2) extend the topological analysis to a wider variety of turbulent flows and include studies of the pressure-gradient field to determine features of the fine-scale turbulent motions that are universal and are flow dependent. The effect of Reynolds number and how the fine scales evolve will also be explored.

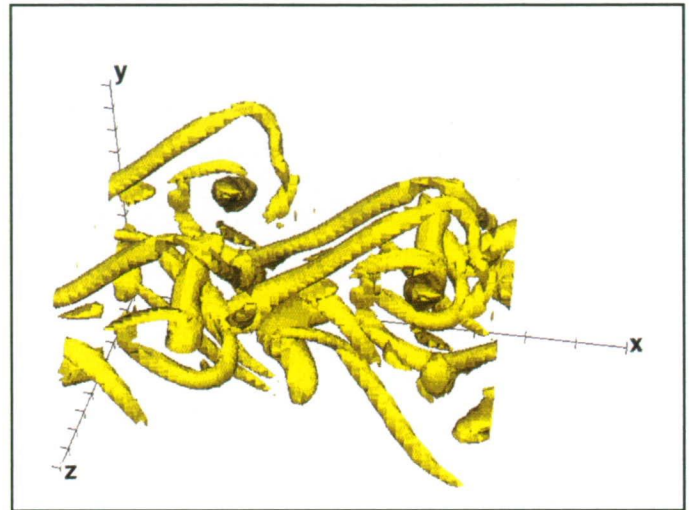

(a)

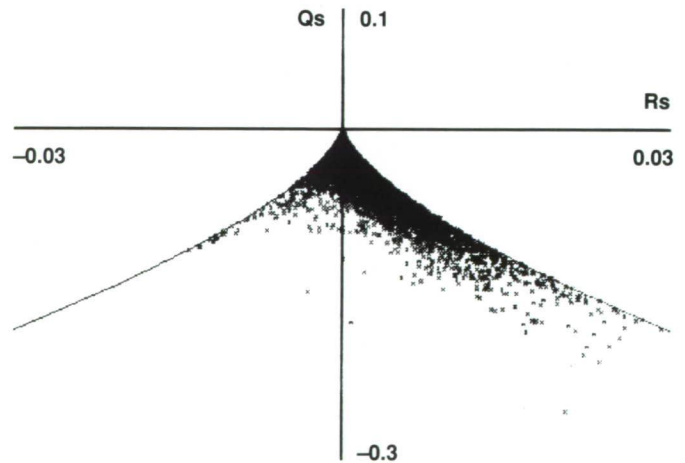

(b)

Simulation of a three-dimensional incompressible plane wake at  $Re = 500$ . (a) Physical space (contours of constant entropy). (b) Strain-rate invariant space.

# Prediction of Advanced Rotor Performance

Frank Caradonna, Principal Investigator

Co-Investigators: John Bridgeman and K. Ramachandran

U.S. Army Aeroflightdynamics Directorate, AVSCOM/NASA Ames Research Center

## Research Objective

To develop computational fluid dynamics (CFD) methods for the prediction of the aerodynamic loads and acoustics of helicopter rotor blades. Principal areas of investigation include steady and unsteady transonic flow, viscous contributions to loads, and the influence of the rotor wake. Research emphasis is placed on the development of codes for immediate use as rotor design tools.

## Approach

Three-dimensional potential equations are solved for an inviscid-rotor flow simulation. The rotor wake is modeled with a combined Eulerian-Lagrangian vorticity-embedding scheme to simultaneously compute rotor aerodynamics and free-wake solutions. An entropy correction term is added to the potential equations to determine viscous effects using either integral- or finite-difference boundary layer methods.

## Accomplishment Description

HELIX-II, the free-wake CFD code, has been applied to analyze a two-bladed rotor in low-advance-ratio forward flight. At low advance ratios, the influence of the rotor wake is important in hover. Unlike hover solutions, the flow is unsteady and it is necessary to grid multiple blades. A grid containing approximately 500,000 points was used for this study with typical run times of 3 hours and 16 megawords of memory. A new unsteady full-potential code, FPX, was developed for application to rotors and propellers. Multiple topologies are treated, entropy and viscosity effects are included, and axial flow capability allows for propeller treatment. The code has been used to predict fuselage wall pressures in the cabin of the XV-15 standard aircraft, advanced technology blades, and has been compared with experimental results from the Army Aeroflightdynamics Directorate hover chamber for a NACA 0012 rectangular blade. Typical runs take 0.5 hour and 8 megawords of memory.

## Significance

Aerodynamic flow phenomena are principally responsible for all crucial rotorcraft performance limitations. Accurate coupled-rotor aerodynamics and free-wake calculations are mandatory for hover performance prediction and forward-flight analysis. Tilt-rotor configurations may play a significant role in both commercial and military markets in the near future. Prediction methods capable of analyzing the performance and acoustics of these vehicles will be vital to providing quality designs.

## Future Plans

The HELIX-II free-wake methodology will be applied to forward-flight investigations for several rotors for which experimental or flight-test data are available. FPX will be used to predict V22 tilt-rotor aerodynamics and compared with experimental data. In a new effort, the vorticity confinement method will be incorporated into an existing Euler/Navier-Stokes code and demonstrated.

## Publications

1. Bridgeman, J. O.; Caradonna, F. X.; and Prichard, D. "The Development of a CFD Potential Method for the Analysis of Tilt-Rotors." Presented at the AHS Technical Specialists Meeting on Rotorcraft Acoustics and Fluid Dynamics, Philadelphia, PA, Oct. 1991.
2. NsiMba, M.; Ramachandran, K.; and Caradonna, F. X. "Computation and Validation of Hovering Rotor Performance." Paper No. 91-41, presented at the 17th European Rotorcraft Forum, Berlin, Germany, Sept. 1991.

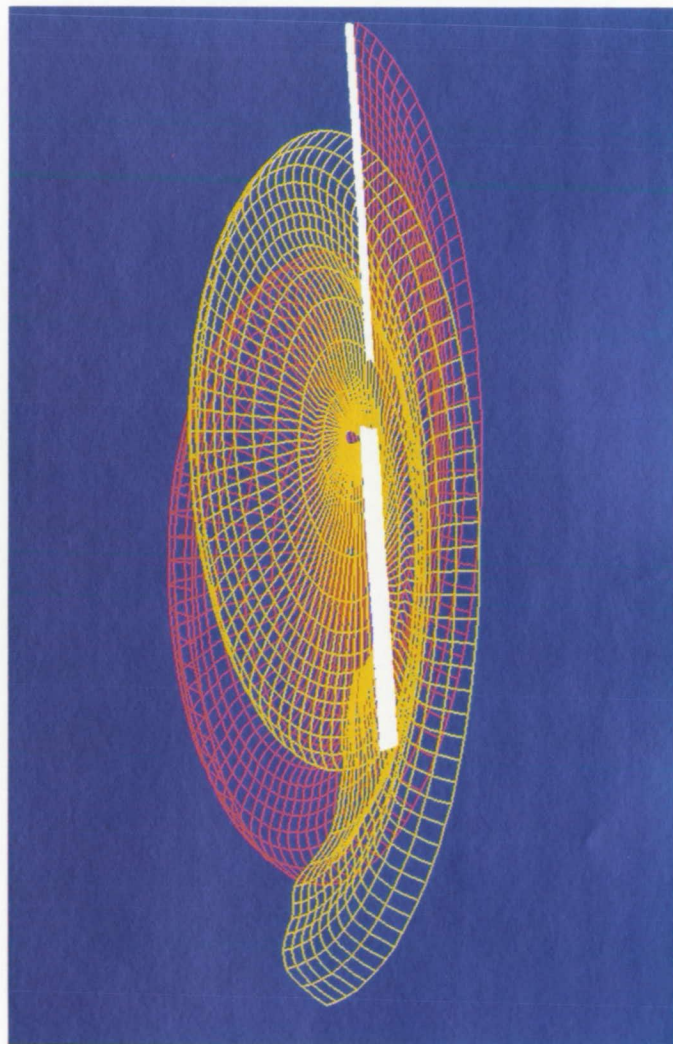

*HELIX-II-computed wake geometry for a two-bladed rotor in forward flight (advance ratio = 0.1).*

# Aerothermal Analysis of Hypersonic Defense Interceptors

R. R. Chamberlain, Principal Investigator

Co-Investigators: Lawrence W. Spradley and Kenneth E. Xiques  
Adaptive Research Corporation

## Research Objective

To develop and improve the methodology for predicting complex hypersonic flows associated with defense interceptors concepts. The computational effort is related to the time accurate prediction of the protective shroud removal from the high endo-atmospheric defense interceptor (HEDI) configuration.

## Approach

The three-dimensional, unstructured, finite-element flow code, FELFLO, is used to simulate the removal of a single shroud petal at Mach 8. The code uses an arbitrary Eulerian-Lagrangian approach to track the body motion and adaptive remeshing to resolve the shock-shock interactions. The time history of the petal motion is computed and compared to wind tunnel data.

## Accomplishment Description

Using the symmetry of the four shroud petals that protect the HEDI forebody, the unstructured grid is constructed for a single petal in one quadrant. Initial conditions for the external flow are assumed to be free stream everywhere except for the shroud cavity (the region between the petal and the forebody), which has no flow. The free-stream flow enters the cavity and raises the pressure so that the shroud petal begins to move. Rotation about a rearward hinge creates physical gaps between adjacent petals, which causes a subsequent reduction in the cavity pressure. This filling and venting phenomenon is characteristic of the shroud-separation event and is well predicted by the present calculation. The petal is eventually released into free flight so that it has both translational and rotational degrees of freedom. The first figure shows the pressure contours along a cut through the centerline of the petal just after it is released. The forebody and petal shocks interact while the high cavity-pressure vents to the rear like an exhaust jet. The petal rotation angle versus time is compared to this experiment and excellent agreement is obtained (second figure). A typical run requires 40 megawords of memory and 50 Cray-2 hours.

## Significance

Many of the latest concepts for theater defense missiles have some kind of shroud separation problem. A significant portion of the design effort requires detailed knowledge of the flow environment inside the shroud cavity, particularly with regard to structural loading on the forebody, shroud petals, and hinges. This work demonstrates that accurate prediction of the highly transient phenomena associated with the separation event is trackable.

## Future Plans

An effort to improve the spatial resolution of the present calculation is under way. Although the time history of the petal motion is significant, certain wave interactions inside the shroud cavity require further definition. Enhanced grid resolution and alternative remeshing strategies are being explored.

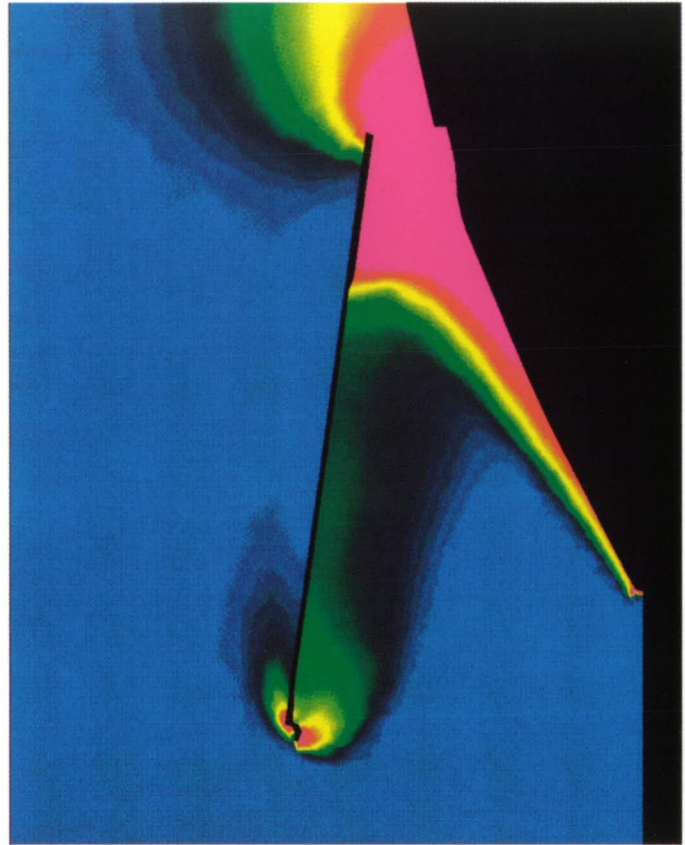

Pressure contours along a cut through the symmetry plane of a single shroud petal.

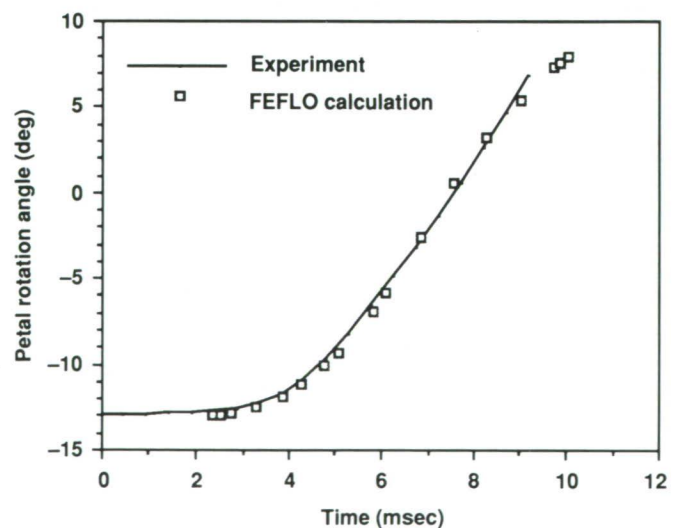

Comparison of the time histories of the petal motion.

# Boost-Phase Detection Study

Dean R. Chapman, Principal Investigator

Co-Investigators: Forrest E. Lumpkin III, Robert W. MacCormack, and Stephane Moreau  
Stanford University/NASA Ames Research Center

## Research Objective

To develop the capability to predict the radiation signature of the heated shock layer ahead of self-propelled bodies and the expanded flow behind them.

## Approach

The radiation signatures are affected by thermochemical nonequilibrium and possibly by low-density phenomena leading to the failure of the linear constitutive relations in the Navier–Stokes equations. To capture the significant flow features, advanced thermochemical nonequilibrium models are refined and incorporated into two-dimensional flow solvers. The Burnett additions to the the linear Navier–Stokes constitutive relations are being employed to quantify low-density effects. For a computed flow field, the desired radiation emissivity and spectra can be computed using a recently modified version of NEQAIR, a nonequilibrium radiation code.

## Accomplishment Description

The performance and range of applicability of the NEQAIR code have been greatly enhanced. Vectorization and algorithm restructuring yielded a significant performance improvement. Removal of very low intensity rotational and vibrational lines from the computation resulted in nearly two orders of magnitude in total improvement. Data more applicable to the conditions of interest for radiative transition probabilities were derived from computational chemistry simulations and experiments. A measured radiation signature compares well to one computed by NEQAIR for a plasma torch experiment designed to represent desired physical conditions, thus validating the new data. A recent NEQAIR computation, which includes an improvement in the kinetic model used to compute nitric oxide electronic excitation distributions, agrees favorably with signatures for high-altitude flights from the first SDIO bow shock ultraviolet test flight. Previous computations under-predicted the emissivity by several orders of magnitude. Reacting-gas simplified Burnett computations were performed for the heated shock layer. Only at high speeds and low densities were these additions found to affect radiation signatures.

## Significance

This work enhances the ability to predict the radiation signatures of ballistic missiles during boost phase. This capability is indispensable when developing a system for targeting hostile missiles. The technologies developed in this study will enable more accurate predictions of heating loads and aerodynamic performance for future transatmospheric vehicles.

## Future Plans

Further additions and enhancements to the radiative transition and kinetic models of the NEQAIR code are planned as data from experiments and computational chemistry simulations become available. Work will continue on enhancing the flow solvers developed in this study and on the study of low-density phenomena in expanding flows.

## Publications

1. Moreau, S. and Laux, C. "A More Accurate Nonequilibrium Air Radiation Code: NEQAIR Second Generation." AIAA Paper 92-2968, AIAA 23rd Plasmadynamics and Lasers Conference, Nashville, TN, July 1992.
2. Laux, C. and Moreau, S. "Experimental Spectrum of an LTE Air Plasma, and Comparison with NEQAIR Theoretical Predictions." AIAA Paper 92-2969, AIAA 23rd Plasmadynamics and Lasers Conference, Nashville, TN, July 1992.

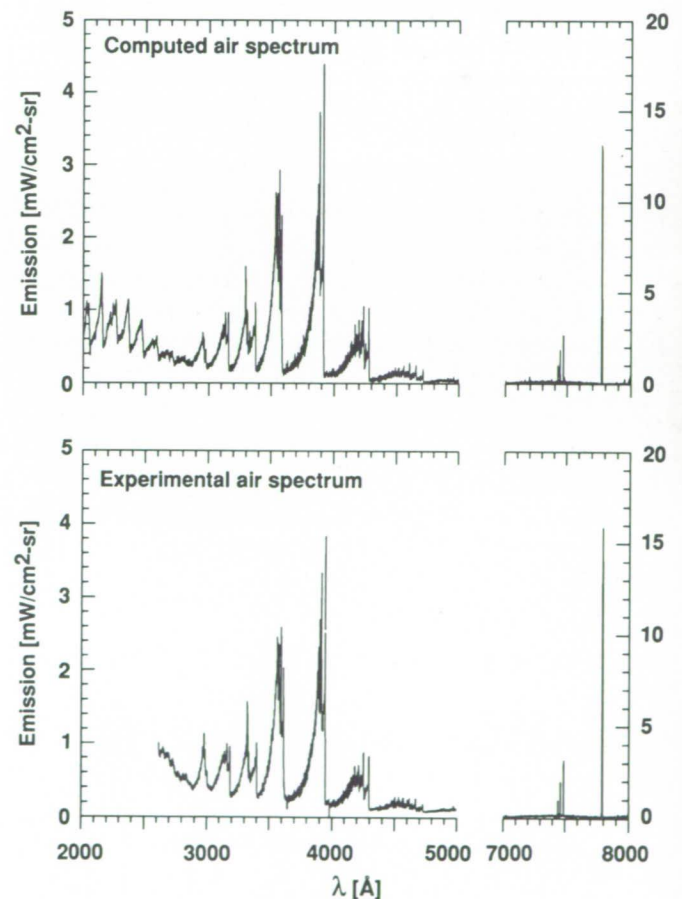

Comparison of measured and computed radiation signatures for a plasma-torch experiment.

# Transonic and Supersonic Flow Past Aircraft Configurations

Denny Chaussee, Principal Investigator  
Co-Investigators: Jolen Flores and Eugene Tu  
NASA Ames Research Center

## Research Objective

To develop computational technology to assess and aid the design of future aircraft, to develop and validate the capability to simulate the viscous flow about wing-body-flap configurations, and to investigate the accompanying flow physics. This was done using a subsonic experiment of Frink.

## Approach

A three-dimensional thin-layer finite-volume Navier-Stokes code was used to compute the subsonic flow about a slender wing-body configuration with trailing-edge flaps. A virtual-zone technique was used in the region of the flap-wing interface. The Baldwin-Lomax turbulence model was used.

## Accomplishment Description

A simulation of turbulent subsonic flow about a slender wing-body with trailing-edge flap deflected 20 degrees at 0 degrees angle of attack and Mach 0.4 was completed. The accompanying figure includes the computed surface pressure and the chordwise surface pressure on the inboard flap. The oil flow shows the complexity of the turbulent flow over a 20 degree deflected flap. Comparisons with the experiment are qualitative for the pressures on the wing and flap system. A typical run required 30 megawords of memory and 50 Cray Y-MP hours.

## Significance

The contribution to controls from flaps is important throughout the Mach and angle-of-attack range. Also, the capability to predict flows for various flap settings can decrease the amount of wind tunnel downtime by reducing the number of runs needed for flap parametrics.

## Future Plans

The finite-volume Navier-Stokes code will be applied to different flaps, including split flaps and vortex flaps. Eventually, the problem will be run in a time-accurate mode with control feedback.

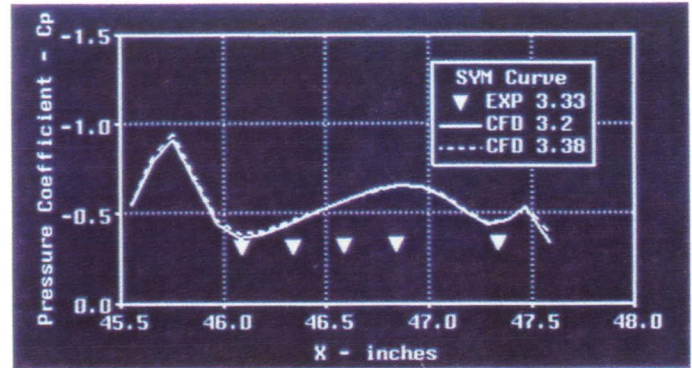

(a)

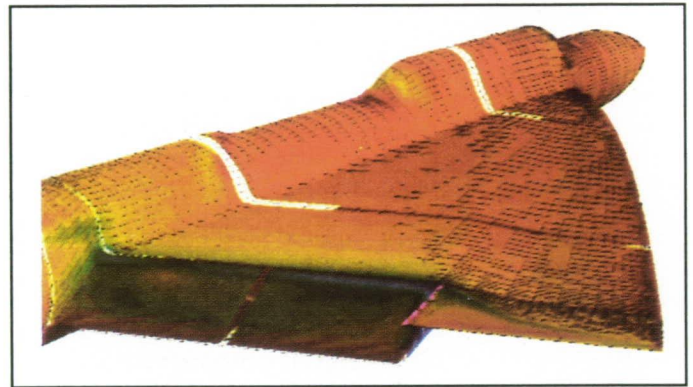

(b)

Subsonic wing-body-flap computation.  $M_\infty = 0.4$ ,  
 $\alpha = 0$  degrees,  $Re = 5.41 \times 10^6$ . (a) Chordwise surface pressure  
comparison center of inboard flap. (b) Pressures on the surface.

# Numerical Analysis of Three-Dimensional Separated Juncture Flows

C. L. Chen, Principal Investigator

Co-Investigator: C. M. Hung

Rockwell International Science Center/NASA Ames Research Center

## Research Objective

To understand the flow structure of various horseshoe vortex systems generated by a cylindrical protuberance mounted on a flat plate.

## Approach

The Reynolds-averaged Navier–Stokes equations are solved to study this generic juncture flow with the unified solution algorithms (USA) series code. The USA code, which is a multizonal finite-volume solver, utilizes a high-resolution total-variation-diminishing scheme. A modified Baldwin–Lomax model incorporating Goldberg’s backflow treatment is utilized in this study. The flow topology is investigated for various Reynolds numbers and Mach numbers. Results are compared with experimental results.

## Accomplishment Description

The various complex laminar- and turbulent-horseshoe vortex structures were computed and analyzed. The upstream, outermost singular point was either a saddle point of separation or a saddle point of attachment. It moved upstream when the free-stream Mach number increased. The size of the vortex structure increased dramatically due to shock-wave and boundary-layer interaction. The flow structures of multiple vortices (up to six) were computed. The computation of supersonic turbulent flow predicted the same features as those indicated by experimental results, such as upstream shock-wave/boundary-layer interaction and a classical horseshoe vortex system. The calculations also provided downstream wake/shock-wave interaction and the near-wake tornado-like vortex structure. The calculations took about 60 Cray-2 hours and 20 megawords of memory for each run.

## Significance

Juncture flows are important in external aerodynamics (including multibody space shuttle junctures, wing–body junctures, and wing–pylon junctures), turbomachinery, submarine conning-tower flow, and applications in meteorology and geology. The results of this effort lead to a better understanding of such complex flow fields and will assist in future design efforts.

## Future Plans

This research will be continued and expanded.

## Publications

1. Chen, C. L. and Hung, C. M. “Numerical Study of Juncture Flows.” *AIAA J.* 30, no. 7 (July 1992): 1800–1807.
2. Hung, C. M.; Sung C. H.; and Chen, C. L. “Computation of Saddle Point of Attachment.” *AIAA J.* 30, no. 6 (June 1992): 1561–1569.

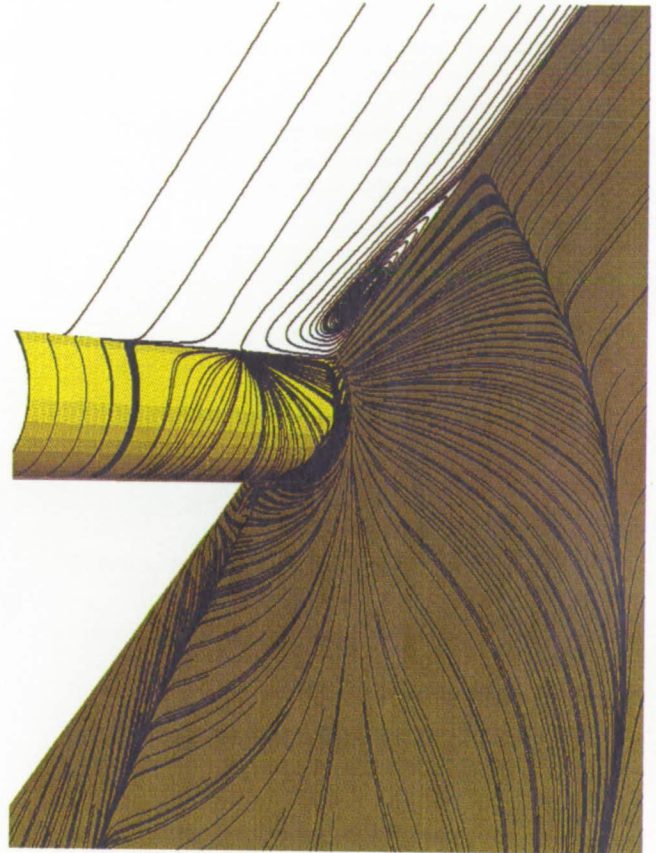

*Overall structure of the juncture flow.*

# Euler Analysis of Turboprop and Turbofan Integration

H. C. Chen, Principal Investigator

Co-Investigators: T. Y. Su, T. J. Kao, and D. A. Naik

The Boeing Company/ViGYAN, Inc./NASA Langley Research Center

## Research Objective

To develop an effective computational capability for the analysis of turboprop and turbofan engine–airframe integration.

## Approach

A general, multiblock, multigrid Euler code (GMBE) has been developed for the analysis of complete airplane configurations with under-wing turbofans or superfans. The volume grid is generated independently. GMBE is a generalized version of a code that was successfully used to address the problem of wing-mounted and aft-mounted turboprop engine–airframe integration. Powered nacelles may be simulated by prescribing inflow and outflow conditions at the fan inlet face and fan/core exit faces respectively. Flow-through nacelles are analyzed by prescribing solid-surface boundary conditions along the inner walls of the nacelle.

## Accomplishment Description

GMBE was successfully executed for a generic low-wing transport with an advanced turbofan nacelle (bypass ratio  $\approx 6$ ).

The volume grid contains approximately 1.2 million grid points and is composed of 32 blocks. A typical solution takes 4 Cray Y-MP hours. The accompanying figure shows that GMBE-computed pressure coefficients compare well with the experimental data on the pylon and fan cowl. Additionally, the GMBE solution indicates that a change in toe angle and pylon trailing-edge closure geometry will improve the propulsion integration.

## Significance

The computational fluid dynamics code that was developed in this project is an effective tool for turbofan/superfan engine–airframe integration. The computed pressure distributions are used to identify, in terms of pressure peaks and gradients, undesirable flow regions in the vicinity of the pylon and nacelle.

## Future Plans

GMBE has been coupled with a NASA Langley direct-iteration surface-curvature algorithm for the inverse design of installed turbofan and superfan nacelles and testing is under way.

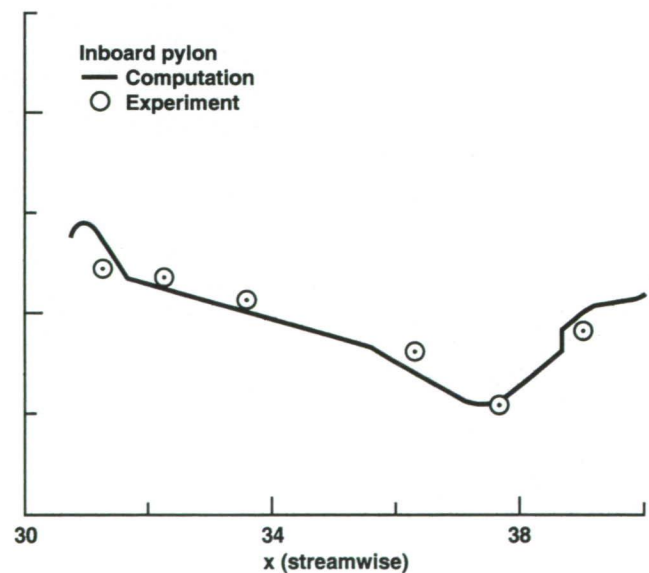
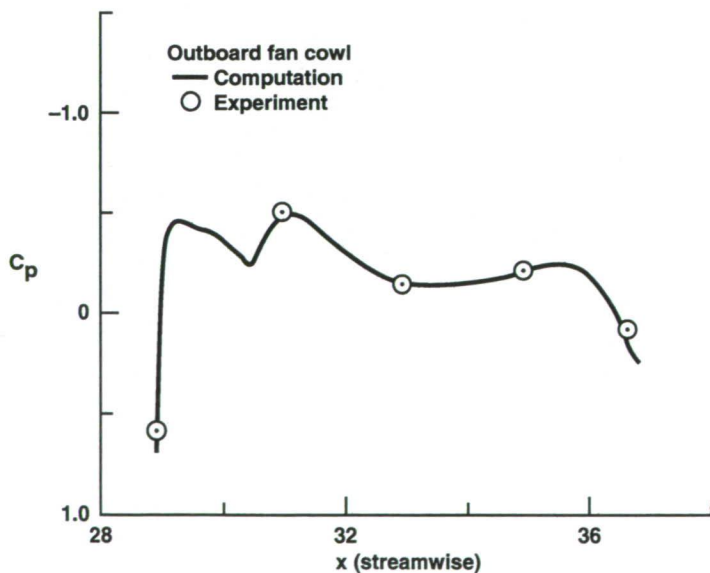
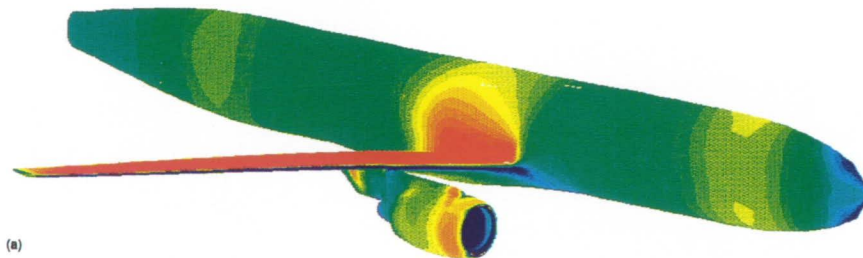

Euler solution of a low-wing transport airplane with turbofan nacelle. Coefficient of pressure range:  $-1.2$  (red) to  $1.0$  (blue).  
 $M_\infty = 0.77$ ,  $C_L \approx 0.55$ .

# Advanced Transonic Wing Concepts

Lee T. Chen, Principal Investigator  
Co-Investigators: K. C. Chang, R. Pelkman, and A. Shmilovich  
Douglas Aircraft Company

## Research Objective

To calibrate and validate three-dimensional Navier–Stokes codes for the analysis of advanced transonic-wing concepts for subsonic transports.

## Approach

The thin-layer Navier–Stokes codes being studied, CFL3D and TLNS3D, were developed at NASA Langley. The CFL3D code is based on an upwind-difference scheme and the TLNS3D code is based on a central-difference algorithm. Wind tunnel experiments and flight-test data are used to validate the numerical solutions obtained for wing–body configurations.

## Accomplishment Description

Several wing–body configurations representing contemporary wing designs and advanced wing concepts were used to exercise the Navier–Stokes codes. Comparisons of the numerical predictions with wind tunnel and flight-test data were made at cruise and near-buffet conditions. For a grid of about 300,000 points, a typical TLNS3D run requires about 2 Cray-2 hours and a typical CFL3D run requires 3–5 hours. The codes require less than 21 megawords of memory.

## Significance

CFL3D and TLNS3D predict the transonic flow characteristics for a variety of wing–body arrangements. More specifically, the codes simulate the progression from a double-shock flow pattern at low lift levels up to the single-shock structure at transonic high lift. This flow phenomenon is typical of advanced wing designs. TLNS3D also provides good correlation of separation progression predictions with flight-test measured buffet progression using the Johnson–King nonequilibrium turbulence model. In particular, the critical spanwise location for the first appearance of separated flow at the trailing edge and the chordwise progression of separation closely agree with the observed characteristics.

## Future Plans

Further comparison of TLNS3D and CFL3D predictions with test data will be made for more wing–body configurations. The multiblock capability of both CFL3D and TLNS3D will be exercised to study the flow for more complex configurations. Emphasis will be placed on the interference flow phenomenon for wing-mounted engine installations.

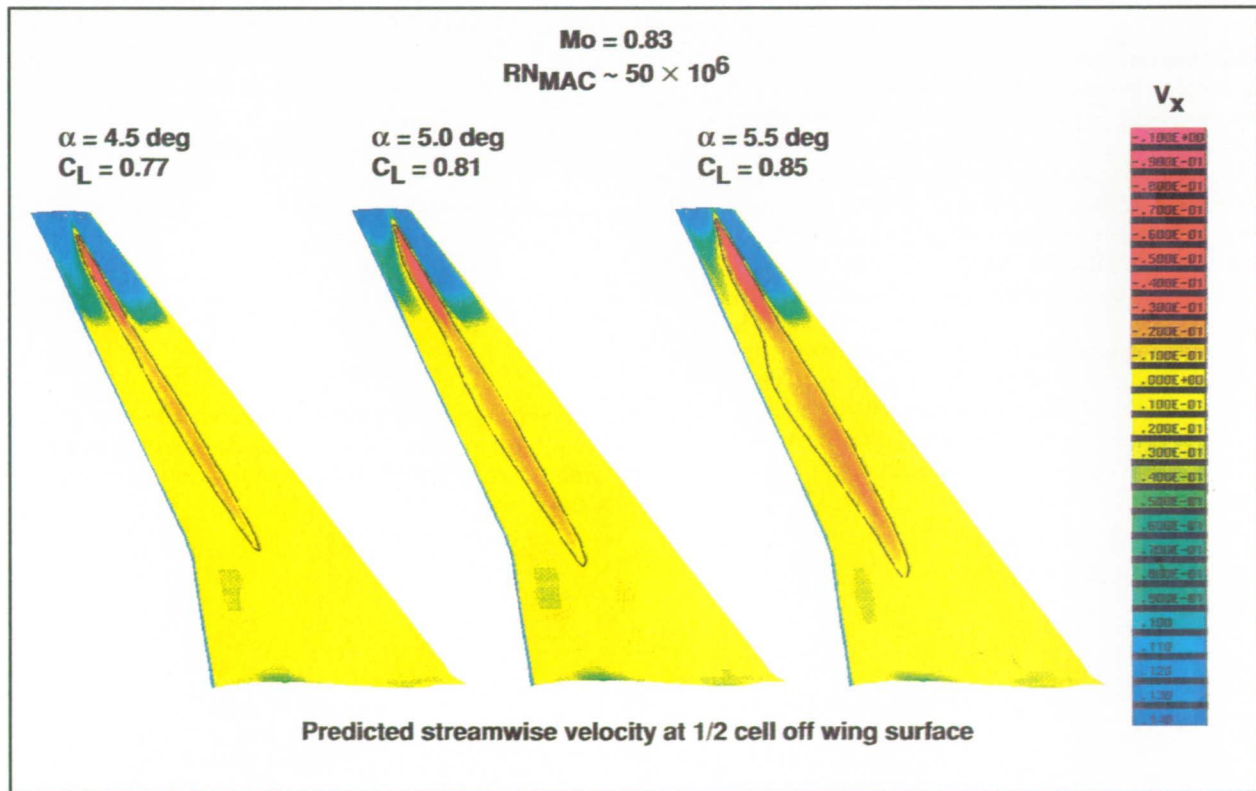

TLNS3D-predicted flow-separation progression for a contemporary wing illustrating the area immersed in reversed flow.

# Turbulence-Model Development for Impinging Jet Flows

Robert E. Childs, Principal Investigator  
Co-Investigator: Laura C. Rodman  
Nielsen Engineering and Research, Inc.

## Research Objective

To use large-eddy simulation to gain knowledge about the physics of impinging jet flows, and to develop an improved two-equation model for these flows based on this knowledge and experimental data. Complex flow fields are generated by the impinging jets associated with thrust reversers and vertical take-off or landing jet aircraft. Accurate turbulence modeling is needed for these types of flows. However, existing models, even advanced models such as the Reynolds-stress transport models, generally perform poorly in complex impinging jet flows.

## Approach

Large-eddy simulations were performed on an impinging jet inclined 45 degrees toward a cross flow with a velocity of 22% of the jet centerline velocity. A compressible Navier-Stokes solver with fourth order spatial accuracy and second order temporal accuracy was employed to perform the simulations. Turbulent inflow boundary conditions were generated in auxiliary simulations of spatially periodic turbulence. Both the dynamical and Reynolds-averaged simulation results were evaluated in the study. Turbulence model development was performed with a different version of the same flow solver. Modifications to the k- $\epsilon$  model that could account for the observed physics were sought.

## Accomplishment Description

The large-eddy simulation requires 20 megawords of memory, and takes 60 single-processor Cray Y-MP hours. The simulation revealed that vortex stretching is an important phenomenon in impinging jet flows. Modifications for the effects of streamline curvature and vortex stretching, consisting of additional source terms in the  $\epsilon$ -equation, were incorporated in the k- $\epsilon$  model. The accuracy of the modified model has proven to be very good. The predicted location of the ground (horseshoe) vortex, which generates a region of low pressure, is a good test of the model's accuracy. The error in the ground vortex core location predicted with the modified model is reduced by 70% or more in comparison to calculations with the standard k- $\epsilon$  model. The model has given good results for three different impinging jet configurations. Grid dependence in the Reynolds-averaged results was shown to be negligible.

## Significance

Previously, the errors in the predicted turbulence in impinging jet flows were large—50% or more. Since these flows significantly depend upon the turbulence, numerical prediction methods were unreliable for flows that involved impinging jet phenomena. Present results indicate that a great improvement in accuracy has been achieved and that this improvement may extend to a range of impinging jet flows.

## Future Plans

To determine its range of applicability, the modified k- $\epsilon$  model will be tested in a wider variety of impinging jet flow calculations.

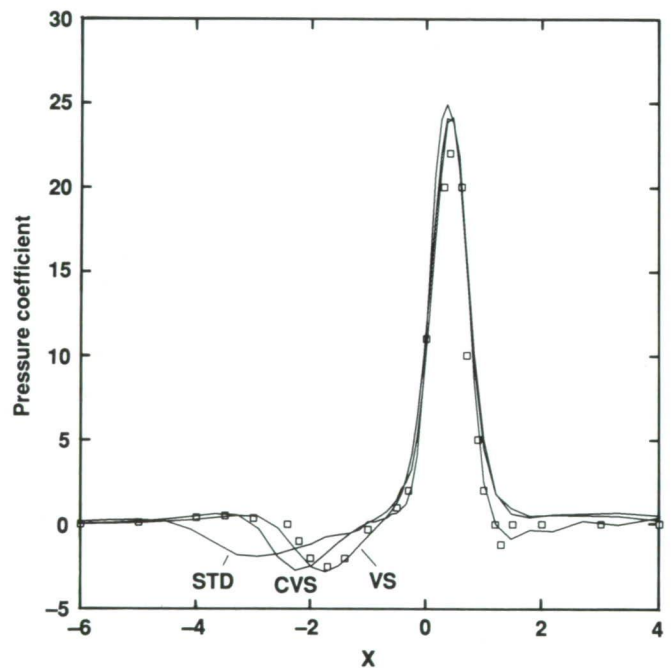

Surface centerline pressure coefficient for a normal impinging jet in cross flow; experimental data and calculations with standard (STD), vortex stretching (VS), and curvature/vortex stretching (CVS) k- $\epsilon$  models.

# Prediction of Turbine Endwall Heat Transfer

Rodrick V. Chima, Principal Investigator  
NASA Lewis Research Center

## Research Objective

A three-dimensional Navier–Stokes code was used to compute endwall heat transfer in a linear turbine cascade at two Reynolds numbers. The cascade was tested at NASA Lewis using a liquid crystal technique to map the endwall heat transfer. Two distinctly different heat transfer patterns were seen at low- and high-Reynolds numbers. The objective of the work was to verify the code by computing the two heat transfer patterns, and to use the computations to explain the physics behind the two patterns.

## Approach

The Rotor Viscous Code three-dimensional turbomachinery analysis code was used. It is a three-dimensional thin-layer Navier–Stokes code with an algebraic turbulence model. A finite-difference formulation and a Runge–Kutta scheme with local time stepping and implicit residual smoothing were used.

## Accomplishment Description

A new algebraic turbulence model for the heat transfer analyses was developed. The model is based on the Cebeci–Smith boundary-layer model, but uses unique integral relations to determine turbulent length and velocity scales. Much of the work was aimed at developing and verifying this model. Computations were made on the Cray Y-MP using a grid with about 300,000 points. Approximately 8 megawords of memory were required. The code is highly vectorized and autotasked, with a measured performance of 710 MFLOPS on a non-dedicated system. The cases run here had low inlet Mach numbers (0.05–0.2) and required 2,500–4,000 iterations (2.5–4 CPU hours) to converge. The accompanying figure shows computed blade and endwall heat-transfer contours for a low-speed case ( $Re = 78,000$ ) expressed as a dimensionless Stanton number. The contours show the heat transfer augmentation around the leading edge of the blade and the increasing heat transfer through the passage. The high-speed results (not shown) exhibit a distinctly different heat transfer pattern. Both patterns agree fairly well with the experimental data.

## Significance

Gas-turbine engine efficiency can be improved by increasing the turbine inlet temperature or by decreasing the amount of coolant air. To use either of these approaches, it is necessary to understand the physics of the heat-transfer process in turbine blade passages and to be able to predict the heat transfer accurately. The code and turbulence model support several turbine experiments at NASA Lewis, including the low-speed cascade, a transonic cascade, and a radial inflow turbine. It is also being used at NASA Lewis for analysis of fan blades and wave rotors, and is available to United States industries and universities.

## Future Plans

Blocked-grid capability is being added to the code. Initial applications will be for detailed analysis of the flow in the tip-clearance region above the rotor blades.

## Publications

1. Chima, R. V. "Viscous Three-Dimensional Calculations of Transonic Fan Performance." *AGARD Conference Proceedings*. Neuilly-Sur-Seine, France, Feb. 1992.
2. Chima, R. V.; Giel, P. W.; and Boyle, R. J. "Algebraic Turbulence Model for Three-Dimensional Viscous Flows." To be presented at the AIAA Aerospace Sciences Meeting, Reno, NV, Jan. 1993.

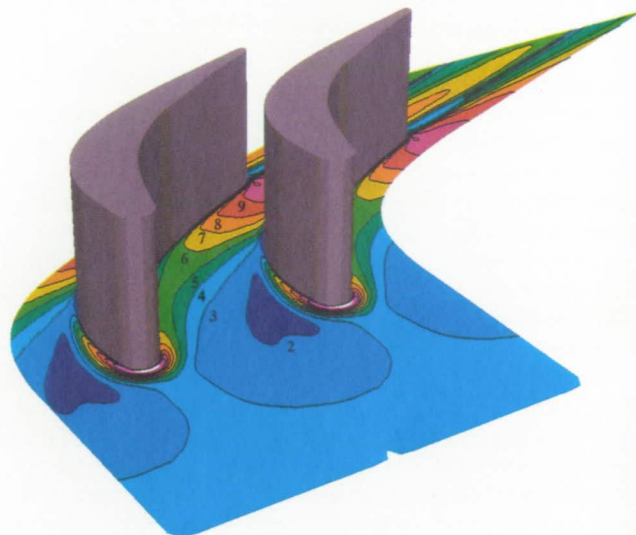

Linear turbine cascade: Stanton number  $\times 1,000$ ;  $Re = 78,000$ .

# Compressible Taylor–Couette Flow

Chuen-Yen Chow, Principal Investigator  
Co-Investigators: Meng-Sing Liou and Kai-Hsiung Kao  
University of Colorado, Boulder/NASA Lewis Research Center

## Research Objective

To investigate and understand the mechanisms of the vortical structure of the compressible flow between two concentric cylinders. The transition behavior of the boundary layer on an axisymmetric body is given a spin motion. This may occur on a rocket or along the shaft of a turbomachine and may drastically affect the performance of the original design.

## Approach

The governing equations are numerically solved employing the implicit approximate-factorization Beam–Warming algorithm. The scheme is formulated using Euler-implicit time-differencing and second-order finite-differencing approximations for all spatial derivatives. It is simulated using a fully vectorized, three-dimensional Navier–Stokes solver, FDL3D1, developed by Miguel R. Visbal at Wright-Patterson Air Force Base.

## Accomplishment Description

The study is to numerically investigate the compressible Taylor–Couette flow with a radius ratio  $R_1/R_2 = 0.5$  and infinite length. The wavelength of a complete Taylor vortex above critical Reynolds number is first evaluated by utilizing a large computational domain for which simple zero-axial derivative boundary conditions are imposed at the two end plans. Using a finer grid system, computation is restarted to improve the solutions so that the pre-calculated wavelength is used as the integration domain and, therefore, the periodic boundary condition can be applied at the end plans. For the case of steady flow, convergence was assured by monitoring the dissipation rates (torques) on both inner and outer cylinders so that altering grid resolution produced no changes in flow topology and introduced only negligible variations between the inner and outer torques. The computational grids for the Taylor–Couette flow are clustered in the radial direction near the surfaces of the inner and outer cylinders and equally spaced in the axial and circumferential directions. Using stretching grids near the solid boundaries would allow a more accurate computation not only to extract energy from the moving wall, but also to resolve rapid variations of flow structures in the boundary layer. For a single wavelength, the grid resolution employed in the flow is  $62 \times 35 \times 31$  in axial, azimuthal, and radial directions, respectively, at Mach 0.1 and a Reynolds number of 100. As Mach or the Reynolds number increases, the required grid size must increase. The computational requirement of the code was found to be approximately 35 words per grid and  $2.0 \times 10^{-5}$  CPU seconds per grid point for each iteration on the Cray Y-MP.

## Significance

The study concludes some preliminary investigations on the formations of the Taylor vortices. The compressible Taylor vortex flows appear to develop single period waves as the wavelength sustains a constant value. Analysis of flow variables strongly supports the concept of an evolving jet-like structure when the Mach number and Reynolds number are increased.

## Future Plans

The evolution of the vortical structure at Reynolds numbers higher than the critical value will be studied and we will provide a detailed account of (1) vortex-loop development at various spike stages during transition and (2) the path the vortical flow takes that leads to a final chaotic state. Numerical methods will be used to study the control of transition with mechanisms such as wall heating or cooling, acoustic excitation, and blowing or suction at the body surfaces.

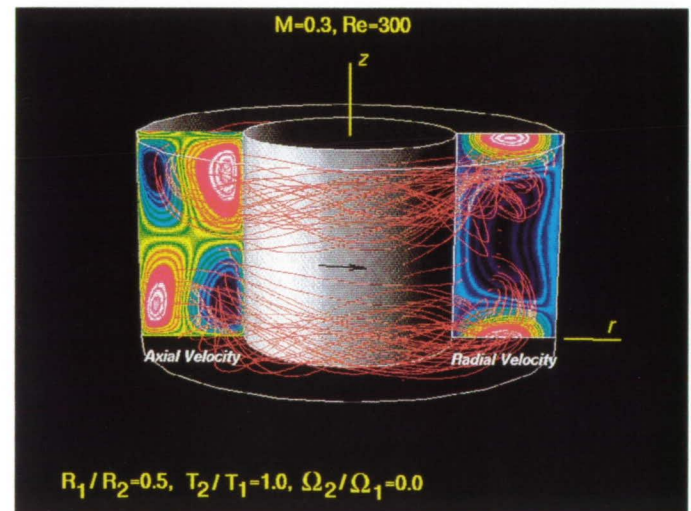

Particle traces and contour plots of axial and radial velocity components.

# Airframe and Inlet Aerodynamics

Wei J. Chyu, Principal Investigator

Co-Investigators: David A. Caughey and Tom I-P. Shih

NASA Ames Research Center/Cornell University/Carnegie Mellon University

## Research Objective

To develop an analytical capability to predict integrated performance of forebody and inlet systems for highly maneuverable aircraft.

## Approach

Adapt and develop Navier–Stokes codes with two numerical approaches, one with a finite difference method combined with a multizonal, two-grid topology and Chimera grid-embedding technique (F3D) to treat flow problems in complex geometries, and the other with a finite-volume method implemented with multigrid diagonal implicit schemes on block structured grids to allow flexibility in grid generation and to improve computational efficiency.

## Accomplishment Description

The F3D Navier–Stokes code was used to study the inlet boundary-layer control by simulating a transonic flow through a circular bleed hole on a flat plate with a plenum. The results of this computation reveal inlet-bleed/shock-wave/boundary-layer interactions that provide valuable information to ongoing inlet experiments. The development of a finite-volume Navier–Stokes code resulted in a unique parallel-block multigrid solution with appreciably improved convergence.

## Significance

The increased maneuvering requirements of advanced aircraft dictate more complicated inlet geometries and operations. Advanced computational techniques permit analysis of more complex inlets, making possible the investigation of a broader range of design variables associated with integration of the forebody and inlet systems and the inlet performance with boundary-layer control.

## Future Plans

Future efforts will focus on code validation cases for complex inlet geometries, including the integration of internal and forebody solutions with various inlet performance control techniques.

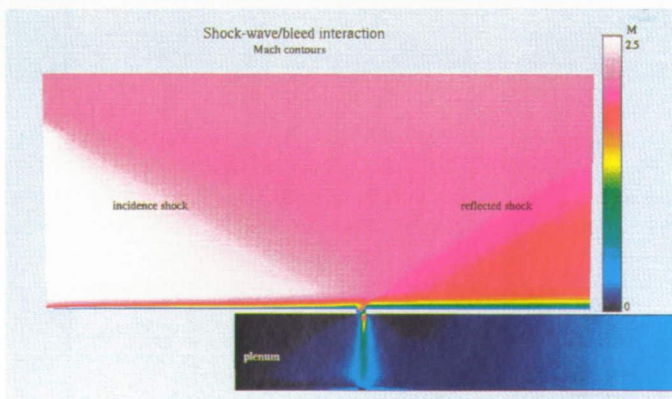
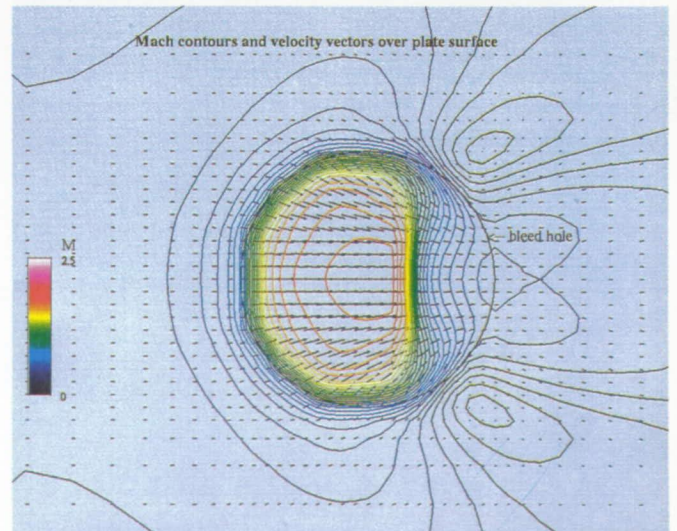
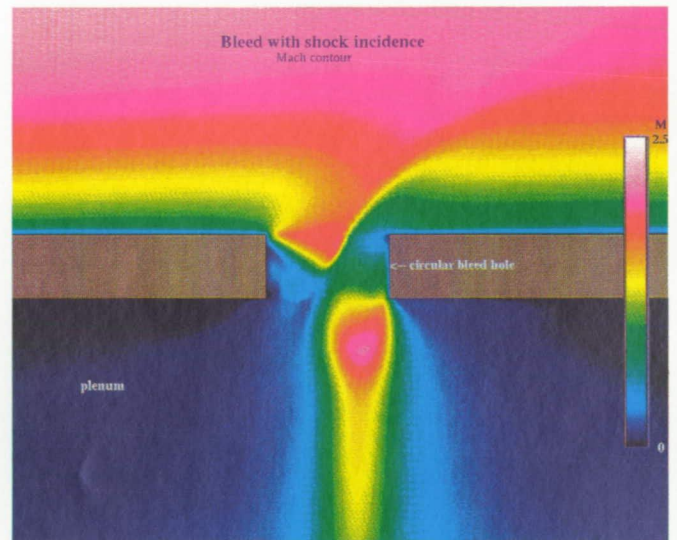

Simulations of a transonic flow through a circular bleed hole on a flat plate with a plenum.

# Generic National Aero-Space Plane Forebody-Inlet Integration

Charles E. Cockrell, Jr., Principal Investigator  
Co-Investigator: Lawrence D. Huebner  
NASA Langley Research Center

## Research Objective

To study the inlet module for a generic hypersonic forebody-inlet model and determine the feasibility of obtaining internal inlet drag force predictions based on computational fluid dynamics (CFD) solutions simulating exhaust flows of body-mounted scramjet propulsion systems.

## Approach

Three-dimensional parabolized Navier-Stokes (PNS) solutions were obtained for the inlet flow field using the General Aerodynamic Simulation Program. Data from CFD solutions were compared to experimental pressure data from a wind tunnel test and were used to obtain predictions for the internal drag force of the inlet module.

## Accomplishment Description

Computational solutions were obtained for the inlet flow field for free-stream conditions of  $M_\infty = 6.0$  and  $Re_\infty = 2.0 \times 10^6$  per foot, and are identical to those in previous wind tunnel tests of a generic forebody-inlet model. The three-dimensional PNS solutions were compared with experimental Pitot pressure data at the inlet exit plane. Analysis of the CFD solutions generally showed good agreement with exit-plane Pitot pressure data. Some discrepancies exist due to an inaccurate prescription of the inflow boundary conditions at the inlet entrance plane. The top figure shows a comparison of CFD Pitot pressure values at the exit plane with the vertical surveys of Pitot pressures taken in wind tunnel tests superimposed. The bottom figure shows a side view of the inlet (flow is from left to right), near the inlet centerline, with computational Pitot pressure values. This view shows qualitative features of the inlet flow field such as the forebody boundary layer swallowed by the inlet on the upper surface and the formation of a shock due to boundary-layer growth on the lower surface. The three-dimensional momentum equation was used to obtain an expression for the internal inlet drag force at the entrance and exit planes of the inlet. The CFD solution pressure data were used to evaluate this force. A typical PNS solution required approximately 38 megawords of memory and 2.9 Cray-2 hours.

## Significance

This analysis provides a method for obtaining the internal inlet drag force of the inlet module under investigation. An accurate value of this force is needed to determine the forces and moments of individual components of wind tunnel models used in powered testing. The internal inlet drag force is difficult to resolve using experimental methods, so an accurate computational procedure is needed.

## Future Plans

Differences exist in comparing the CFD solutions with experimental Pitot pressure values at the inlet exit plane. A CFD solution of the forebody flow field may be required to initialize the inlet solution. Future work will focus on obtaining solutions of the forebody flow field to initialize inlet flow-field solutions.

## Publication

Cockrell, C. E. and Huebner, L. D. "Generic Hypersonic Inlet Module Analysis." AIAA Paper 91-3209, 9th AIAA Applied Aerodynamics Conference, Baltimore, MD, Sept. 1990.

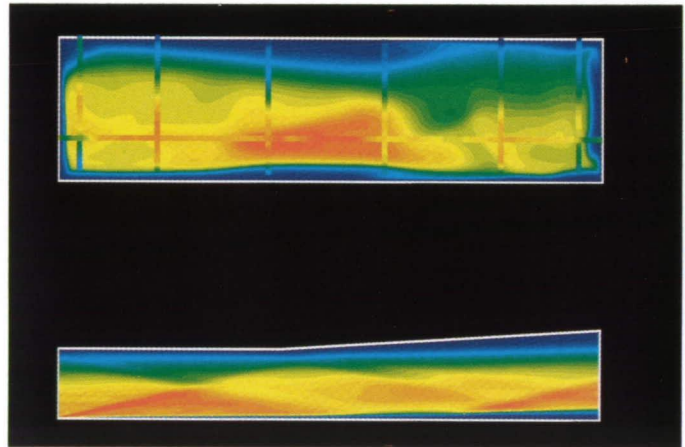

Exit plane (top) and inlet center line (bottom) Pitot pressure values from a three-dimensional parabolized Navier-Stokes solution of a hypersonic inlet module. The experimental Pitot pressure values are superimposed on the exit plane values and are shown as vertical and horizontal bars. The Pitot pressure values range from 0.0 (dark blue) to 8.0 (dark red) pounds per square inch.

# Three-Dimensional Afterbody Flow with Jet Exhaust

William B. Compton, III, Principal Investigator  
Co-Investigator: Khaled S. Abdol-Hamid  
NASA Langley Research Center/Analytical Services and Materials, Inc.

## Research Objective

To numerically investigate the propulsion integration effects on a fighter airplane at subsonic, transonic, and supersonic speeds. An intermediate goal is to develop and validate a three-dimensional Navier–Stokes numerical method to investigate the problem. Steps include obtaining accurate solutions for afterbodies with attached and massively separated flows, including the internal nozzle flow and jet exhaust in the calculations, and including tails and multiple jets.

## Approach

The multiple-block versions of the CFL3D and PAB3D three-dimensional Navier–Stokes codes are used as a basis for the method. The codes employ the finite-volume principle and feature upwind-biased flux-difference splitting combined with a gradient-limiting procedure to ensure monotonicity across discontinuities. Areas of research include the evaluation of both algebraic and two-equation turbulence models for predicting attached and massively separated flows over afterbodies typical of those for advanced fighters. For validating the numerical techniques, the computational effort is correlated with highly detailed experiments in the Langley 16-Foot Transonic Tunnel, the Basic Aerodynamic Research Tunnel, and the Jet Noise Laboratory.

## Accomplishment Description

Simulations have been made for the external flow, the jet exhaust plume, and the internal nozzle flow at free-stream Mach numbers from 0.80–1.20. Jet total pressure ratios ranged from 1.5–9.8 (from below to above the design value). The computations, made with algebraic turbulence models, successfully predicted the qualitative jet-exhaust effects on the afterbody flow. However, when massive shock-induced separation on the afterbody exists, the ability to predict the shock locations and pressure rises downstream of the shocks vary from good to fair. A typical solution takes approximately 20 megawords of memory and 40 Cray Y-MP hours. In addition to these investigations, a two-equation turbulence model has been added to the code PAB3D and tested in the jet plume.

## Significance

In a high performance fighter, 40–50% of the drag is associated with its afterbody. In this region, flows over the fuselage and empennage merge and further interact with the propulsive exhaust to create a flow field that is complex, rotational, and strongly interactive. A numerical procedure to analyze this flow for advanced configurations would be useful in designing new airplanes.

## Future Plans

The two-equation model will be tested for wall-bounded shear flows on the afterbody. In addition, the computations will be compared to detailed laser Doppler velocimeter, pressure, and hot-film data taken inside the nozzle and in the plume.

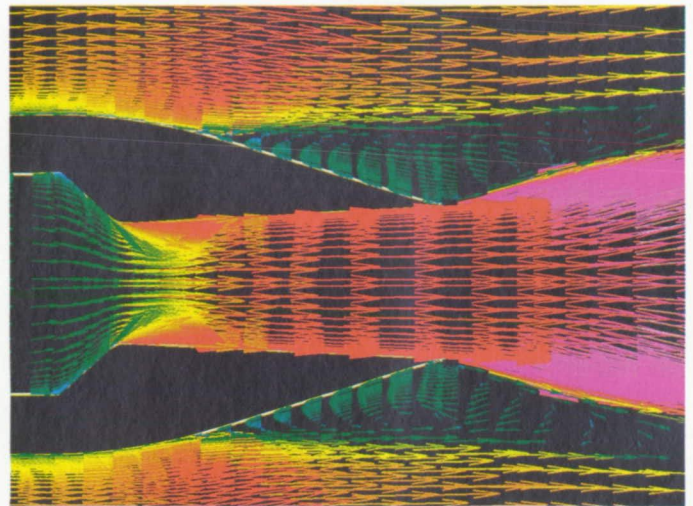

Velocity vectors colored by Mach number. Vertical plane of symmetry:  $M_\infty = 1.20$ , nozzle pressure ratio = 9.8,  $R = 20.5 \times 10^6$ .

# Analyses of F/A-18E/F Upgrades

Raymond R. Cosner, Principal Investigator

Co-Investigators: F. Creasman, R. S. Dyer, T. D. Gatzke, J. A. Johnson, P. J. Malloy, W. W. Romer, and P. G. Willhite  
McDonnell Aircraft Company

## Research Objective

Computational fluid dynamics (CFD) analysis methods are being developed to complement wind tunnel testing in two key areas. First, CFD codes combined with NASA structural analysis models are being developed to compute aeroelastic load increments to wind tunnel data. This will allow engineers to compensate for the flexibility of flight vehicles, compared with rigid wind tunnel models. These aeroelastic modifications to flight loads can be significant in setting structural design requirements. The second area of investigation is to develop methods to correct wind tunnel data for support-system interference. Test data are modified by the presence of a support sting and by distortion of the aerodynamic geometry for physical mounting of the model on the sting. These "sting and distortion" increments can have a significant impact on estimates of flight performance.

## Approach

Multiblock grids were generated for 10 near-complete geometries from the F/A-18 family. All grids included the fuselage, strake, wings, and tails. Some also included flowing inlets and nozzles, a wingtip missile, a wind tunnel support system, and/or wind tunnel walls. Subsonic and transonic solutions were executed to develop engineering procedures for obtaining the best possible accuracy in predicting aeroelastic flight loads and

sting/distortion increments. Accuracy was assessed using wind tunnel and flight data from the YF-17, F/A-18A, and F/A-18C aircraft. Predictions were executed for the F/A-18E aircraft in advance of confirming wind tunnel tests.

## Accomplishment Description

Accuracy of 2–3% was demonstrated for wing root bending moment at Mach 0.9. The flow over the wing at this condition is dominated by viscous interactions, and is substantially modified by elastic deformations of the wing in flight. Accurate sting and distortion corrections were obtained at Mach 0.85 for F/A-18 models tested in the polysonic wind tunnel.

## Significance

Both aeroelastic increments and sting/distortion increments demonstrated new CFD capabilities that complement wind tunnel testing. Each showed that CFD analysis can increase the value of wind tunnel data by correcting for limitations that otherwise cannot be assessed adequately prior to flight testing.

## Future Plans

The elastic loads prediction capabilities will be tested and improved for additional limiting conditions, including asymmetric states. The sting/distortion correction methodology will be extended across the transonic range, from Mach 0.6–1.2.

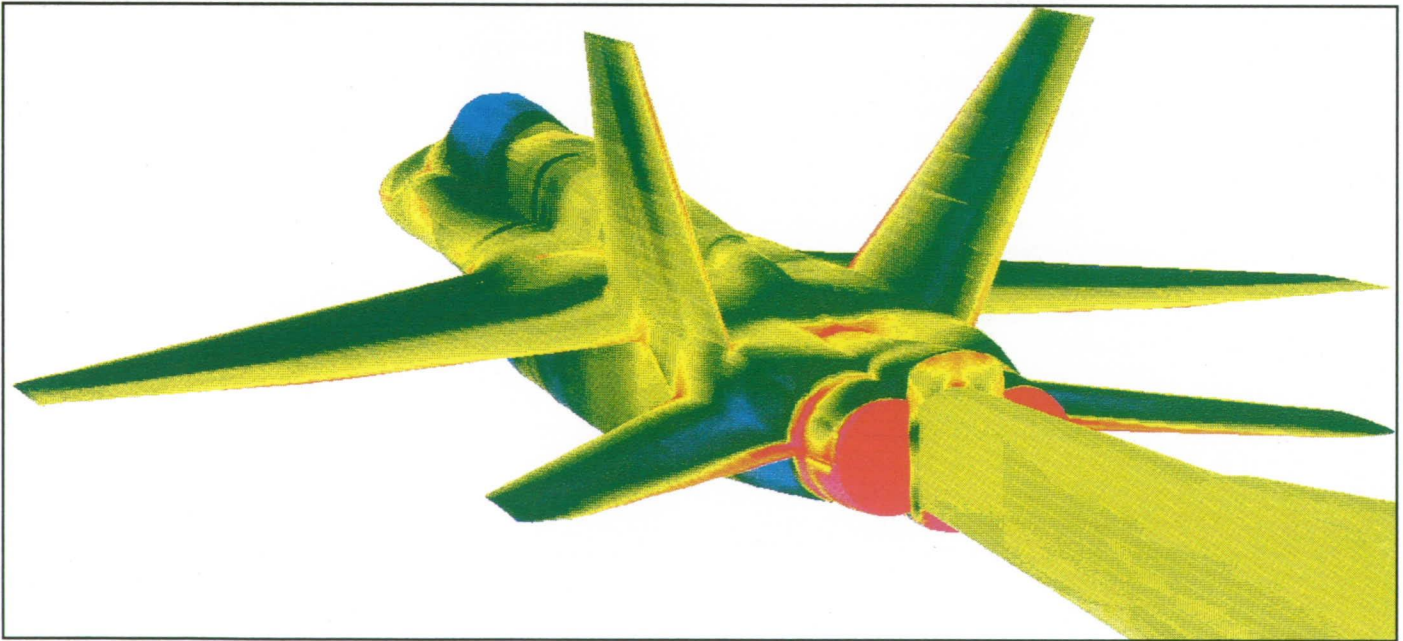

*Sting-mounted F/A-18C with a distorted aft end.  $M = 0.85$ ,  $\alpha = 0.0$ .*

# Endwall and Casing Treatment Flow in a Transonic Fan Rotor

Andrew J. Crook, Principal Investigator  
General Motors Corporation, Allison Gas Turbine Division

## Research Objective

To determine the stall inhibiting features or mechanisms of casing treatment (particularly circumferential grooves) and to identify the important geometric parameters of the treatment. An important preliminary objective is to understand qualitatively the roll of the passage shock and the tip-clearance flow in a stalling or unstalling transonic rotor since this is the undesirable flow condition that casing treatment often delays.

## Approach

Three-dimensional Euler and Navier–Stokes solutions are run to a steady state for the rotor geometry. Exit pressure is raised and more steady solutions are found to simulate the throttling of the rotor.

## Accomplishment Description

Euler and Navier–Stokes solutions were obtained for the flow field about a turbomachinery fan section consisting of a transonic rotor, two downstream ducts, and guide vanes in those ducts. The solutions were generated with a finite-volume explicit procedure that contained an average passage formulation for neighboring blade-row effects. The accompanying figure shows a Navier–Stokes solution about the rotor of the GMA 3007 fan section. Fluid streamlines originating in the tip-clearance region are seen as black lines. The streamlines show the influence of the clearance flow and the trajectory of the vortex in the passage. Contours of relative total pressure are shown on a plane just downstream from the rotor trailing edge.

## Significance

Casing treatment can improve surge margin in fans and will be implemented in the fan development of the integrated high-performance turbine-engine technology program. While the casing treatment's potential for performance improvement is well known, a complete explanation of the stall suppressing mechanism has not been established. Analysis of fan-rotor stalling or unstalling provides a better understanding of the general endwall flow problem.

## Future Plans

Circumferential grooves on the case over the rotor will be modeled. Performance of the treated geometry will be simulated up to the stall or numerical divergence point and solutions will be compared and analyzed.

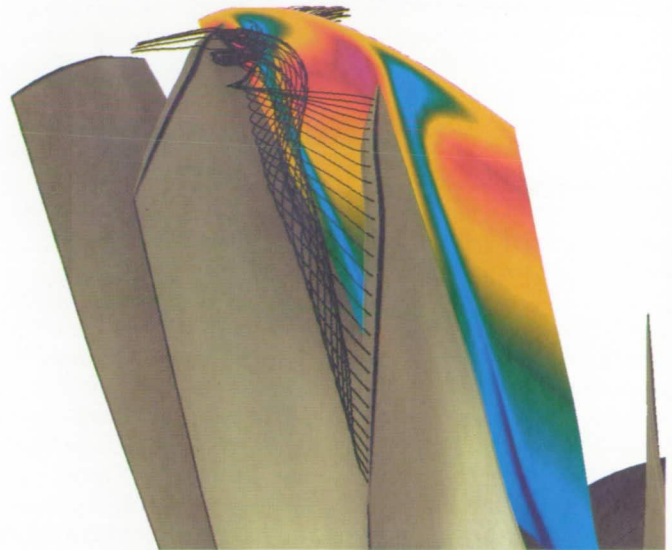

*Navier–Stokes solution about the rotor of the GMA 3007 fan section.*

# Fighter Acoustic-Load Predictions

Richard D. Crouse, Principal Investigator  
Northrop Corporation

## Research Objective

To develop and execute a set of procedures to calculate the unsteady aeroacoustic flow-field environment using computational fluid dynamic methods.

## Approach

The flow field within and around the cavity is calculated using existing three-dimensional Navier–Stokes flow codes. The time-varying pressure field is transformed with a Fourier transform to a frequency domain. This allows the identification of the frequencies and the amplitude of the varying pressure.

## Accomplishment Description

A three-dimensional grid consisting of 899,475 grid points was generated within and above a cavity and flat plate. The cavity model matched the weapon's internal carriage and separation program test fixture with a length/depth of 4.5 and a length/width of 4.5. The Mach number studied was 0.6. ARC3D was run in a time-accurate mode for 232 milliseconds (23,200 iterations). The pressure versus time was saved for various wall locations along with full-flow solutions at every 1,000 iterations. The time-varying pressure was converted with a fast Fourier transform to sound pressure level versus frequency. These three-dimensional results will be compared to previous two-dimensional computations and to experimental results. The accompanying figure shows the pressure versus time at one location within the cavity after the startup transients have dissipated. This three-dimensional computation required 400 Cray-2 hours and 32 megawords of memory.

## Significance

Acoustic load prediction is needed when considering the increased performance levels of advanced tactical air vehicles. This study will provide an extremely useful tool to aid in the design of new vehicles. The computational means will enable solutions to be calculated on a variety of topologies and over a vast flight regime. It will not present case-dependent empirical results, nor simply recalculate old data. Rather, it will have applicability in all stages of aircraft design, such as further analysis of existing geometries, development of present configurations, and research in future programs.

## Future Plans

The methodology will continue to be applied to three-dimensional internal weapon cavity flow. This will include analysis of innovative designs to reduce the aeroacoustic loading within the cavity. The effect of boundary layer control, spoilers, and sloped bulkheads will be considered. The methodology for predicting aeroacoustic pressure fluctuations in three-dimensional cavities will be applied to various geometries to show the effect on the forces expected within the cavity.

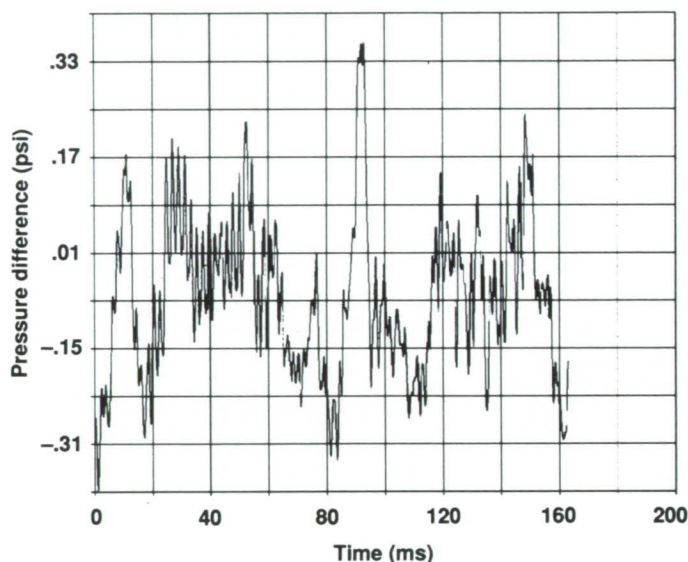

*Pressure versus time at one location within the cavity after the startup transients have dissipated.*

# Flexible Aerobrake Aerothermodynamic Study

M. I. Cruz, Principal Investigator

Co-Investigators: D. E. Ressler, T. P. Shivananda, and E. F. Zabrensky  
TRW, Federal Systems Division/TRW, Ballistic Missiles Division

## Research Objective

To validate and utilize computation fluid dynamic simulations to determine the aerodynamic and thermodynamic environments an aerobraking vehicle would experience during approach and landing on the Martian surface.

## Approach

Perfect gas, equilibrium, and nonequilibrium Navier–Stokes solvers combined with current grid generation methods are used in vehicle parametric studies. The sensitivity of drag coefficient and surface heat transfer rates to variations in flexible and rigid aerobrake geometry was derived.

## Accomplishment Description

Two axisymmetric Navier–Stokes solvers developed at NASA Ames have been used to obtain flow field solutions for candidate aerobrake vehicles. The solvers incorporate both equilibrium and nonequilibrium Martian chemistry ( $\text{CO}_2\text{--N}_2$ ). The non-equilibrium thermochemical solver incorporates surface catalysis enhancing the predicted heat transfer. Results from the simulations have been compared with available ground-test data for similar configurations and agree quite well. The initial conditions for the simulations have been obtained from 7 km/sec direct entry trajectories of the Mars Environmental Survey mission. The results of the simulations have shown the vehicle drag is maximized with a 70 degree cone angle. The vehicle thermal loads are manageable using available rigid heat-shield materials with the nonequilibrium thermochemical results displaying 30% higher surface heat flux than the equilibrium results. Each solution required approximately 10 Cray-2 hours.

## Significance

The current studies have shown that a 7 km/sec direct entry using aerobraking on the approach and descent to the Martian surface is attainable with current technology. Reliance on current fluid simulation is necessary for the design and analysis of the aerobraking vehicles.

## Future Plans

Analysis will continue using the codes for flow-field simulations at other points on the trajectories, including perturbed trajectories.

## Publications

1. Ressler, D. E.; Shivananda, T. P.; Zabrensky, E. F.; and Cruz, M. I. "Drag and Heat Transfer Calculations about a MESUR Aerobrake Vehicle." AIAA Paper 92-2684, AIAA 10th Applied Aerodynamics Conference, Palo Alto, CA, June 1992.

2. Post, D. L. and Cruz, M. I. "CFD Application to Flexible Aerobrake Design for Mars Entry." AAS Paper 91-424, AAS/AIAA Astrodynamics Specialist Conference, Aug. 1991.

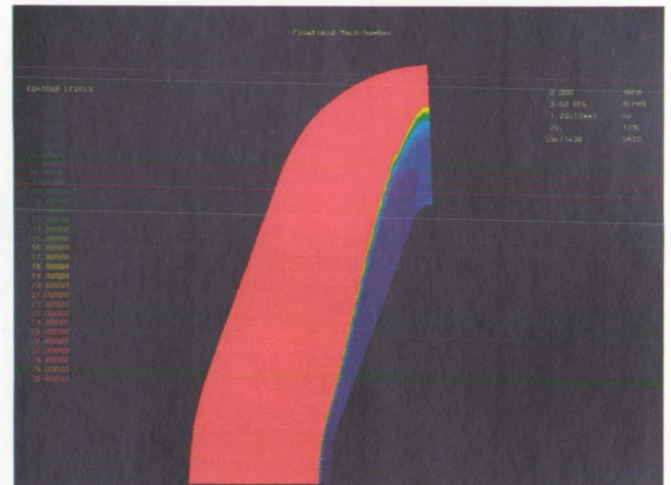

(a)

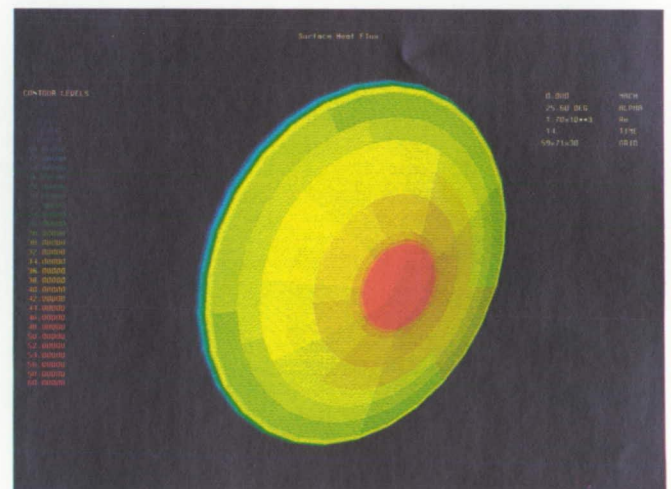

(b)

Mars Environmental Survey flow-field Mach number contours (a), and fully catalytic wall heat flux (b) are shown at  $M = 31.0$ ,  $Re = 1.10^5/\text{meter}$ ,  $\alpha = 0.0$ .

# Particle-Gas Dynamics in the Protoplanetary Nebula

Jeffrey N. Cuzzi, Principal Investigator

Co-Investigators: Joelle Champney and Anthony Dobrovolskis

NASA Ames Research Center/A.T.M., Inc./University of California, Santa Cruz

## Research Objective

To model the primordial disk-shaped nebula from which the planets formed. The stage studied is when a particulate phase has condensed out of the cooling gas and the particles have grown to sufficient size to settle into a layer near the midplane of the nebula. Here, the particle-mass density becomes much greater than that of the local gas. Because the gas is pressure supported and the particles are not, a small, but significant, orbital velocity difference results between the gas and particle phases. The resulting wind shears and turbulence in the gas phase cause both advective and turbulent transport of the particles and gas relative to their unperturbed states. It was during this phase that the primitive meteorites formed.

## Approach

We developed a fully viscous, compressible, two-phase flow model of the nebula that solves the gas and particle conservation and momentum equations in the rotating system using a perturbation technique. The turbulent boundary layer surrounding the particles is modeled with a Prandtl model and a  $k-\epsilon$  model. We developed a model for the particle Schmidt number to couple our mean flows and turbulence into upward diffusion of the particle phase, which balances their downward settling tendency. Thus, the dynamics of the gas and particle phases are fully coupled in a system with significant feedback.

## Accomplishment Description

Using a fully Reynolds-averaged formulation, with correlation terms modeled by a generalized gradient-diffusion hypothesis, we have determined the mean gas and particle flows and the vertical diffusion of particles at a variety of locations in the protoplanetary nebula and in a possible circumplanetary nebula. At each location we have run particle size cases, including particles of between 1–1,000  $\mu\text{m}$  radius with internal density of 0.1–1.0. A typical run requires 1 Cray-2 hour and 1 megaword of memory to reach a non-oscillatory state for each set of model parameters.

## Significance

Particles must grow to at least 1,000 kg mass before being able to accumulate under their own gravity. This contradicts a widespread belief in a “gravitational instability” that would lead immediately to the formation of planetesimals. Our result implies that growing particles probably undergo significant spatial, physical, and chemical evolution as they grow.

## Future Plans

We will extend the code to two dimensions and to cover a range of particle sizes simultaneously. We will also study the three-dimensional clumping of particles in turbulence.

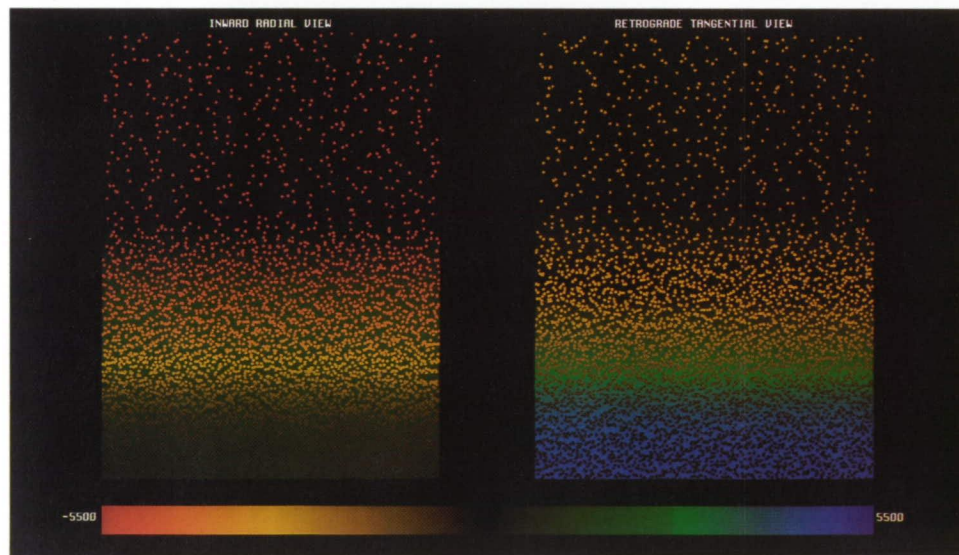

*Solutions for the mean radial, axial, and azimuthal velocities of gas (smooth colors) and particles (dots), as a function of vertical distance 0–20,000 km from the nebula midplane—a very small scale compared to the thickness of the nebula gas disk at this location (about 10 million km). Velocities (cm/sec) are referenced to an observer moving with the unperturbed gas and particles respectively; (a) looking inward, (b) looking backward (away from direction of orbital velocity). The spatial density of the dots is proportional to the logarithm of particle density. A layer is concentrated around the nebula midplane. Within this layer the gas is driven to a higher rotation rate than outside the layer. Outside the layer, the particulates drift inward toward the forming sun, while near its upper boundary the gas is wafted gently outward across the face of the particle layer. Near the midplane there is a slow outward gas flow and a slow inward particle drift. Image created by Robert Hogan of Synernet, Inc.*

# Dynamical Modeling of the Solar Atmosphere

Russell B. Dahlburg, Principal Investigator

Co-Investigators: S. K. Antiochos, Jill P. Dahlburg, and J. T. Karpen

Naval Research Laboratory

## Research Objective

To investigate turbulent magnetohydrodynamic (MHD) processes in the solar atmosphere.

## Approach

Direct numerical simulation, using spectral methods, of the dissipative compressible and incompressible MHD equations in two- and three-dimensional geometries.

## Accomplishment Description

We used our spectral-method codes to investigate transition to MHD turbulence in three-dimensional magnetic reconnection via secondary instability (a typical run requires 8 megawords of memory and 10 Cray-2 hours). The accompanying figures illustrate the evolution of the secondary mode. Contours enclosing the magnetic neutral lines in the plane of the three-dimensional electric-current sheet are shown. Two periods of the mode are shown in  $x$ , with a magnetic O-line in the center.

## Significance

Magnetic reconnection is an important energy release mechanism for solar activities such as flares and coronal heating. Classical analyses generally show that magnetic energy is transformed into heat and kinetic energy on the relatively slow dissipative time scale. Our work has identified a process that enables the magnetic field to release energy on the ideal time scale.

## Future Plans

To extend the present study to the case of electric-current sheets and study the response of finite-length magnetic arcades to photospheric footpoint shearing.

## Publications

1. Dahlburg, R. B.; Antiochos, S. K.; and Zang, T. A. "Dynamics of Solar Coronal Magnetic Fields." *Astrophys. J.* 383 (1991): 420.
2. Dahlburg, R. B.; Antiochos, S. K.; and Zang, T. A. "Secondary Instability in 3D Magnetic Reconnection." NRL Memorandum Rept. 6966, 1992.

Contour levels	0.000	Mach
0.00000	0.00 deg	Alpha
0.00200	50.00	Re
0.00400	44.00	Time
0.00600	$33 \times 33 \times 65$	Grid
0.00800		
0.01000		

Contour levels	0.000	Mach
0.00000	0.00 deg	Alpha
0.00200	50.00	Re
0.00400	$1.33 \times 10^2$	Time
0.00600	$33 \times 33 \times 65$	Grid
0.00800		
0.01000		

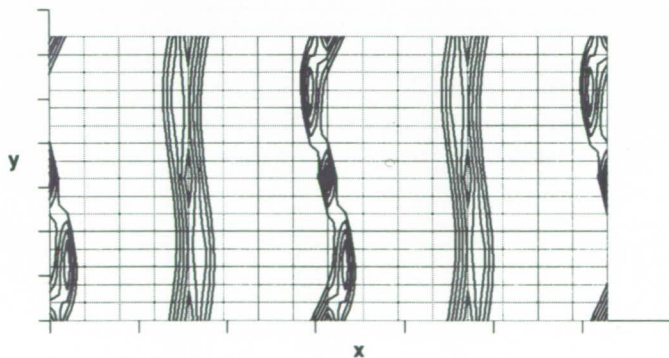

(a)

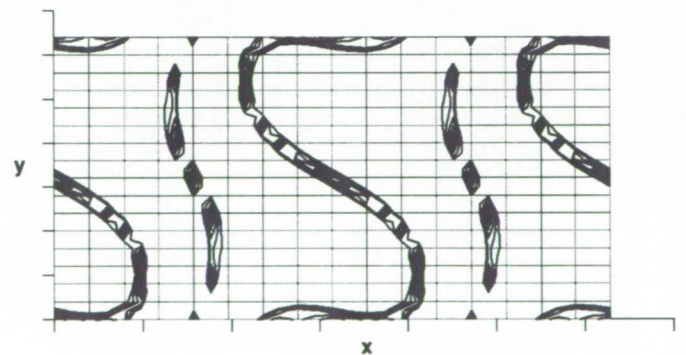

(b)

The evolution of the secondary mode (a) at an early time and (b) during impulse phase.

# Simulation of Turbulent Jets for Aeroacoustic Applications

Sanford M. Dash, Principal Investigator

Co-Investigators: Neeraj Sinha, Brian J. York, and Robert A. Lee  
Science Applications International Corporation

## Research Objective

To develop a computational methodology for simulating the structure of turbulent, imperfectly expanded jets. This research is in support of the High-Speed Civil Transport program and focuses on the interpretation of jet data and jet noise suppression concepts.

## Approach

Initial work has focused on the utilization of Reynolds-averaged Navier–Stokes (RNS) methodology with advanced turbulence models to simulate the mean flow structure of axisymmetric jets with shocks, jets with plug centerbodies, nonaxisymmetric (rectangular/elliptical), and multiple jets. The approach has involved the exploration of new turbulence models (compressible-dissipation model with pressure dilatation terms) to deal with high Mach number compressibility effects in RNS codes such as PARCH and CRAFT.

## Accomplishment Description

The compressible-dissipation models of Sarkar and Zeman were reduced to  $k-\epsilon$  form and assessed using a high-speed shear-layer data base. A new version of  $k-\epsilon$  was formulated ( $k-\epsilon$  CD) unifying the models by adding pressure dilatation terms and additional terms to enforce agreement with data at high Mach numbers. The new model has improved behavior over that of  $k-\epsilon$  for high-speed jets and shear layers. Each run requires 10–40 megawords of memory and 10–20 Cray-2 hours depending on the grid size.

## Significance

The ability to simulate high-speed jet structure has been greatly enhanced by this research. A new turbulence model is under development and is extremely promising. A building-block approach to extend capabilities to more complex flows is being guided by newly obtained data.

## Future Plans

The jet research codes will be applied to flows of increasing complexity. Unsteady jet flows will be investigated using large-eddy simulation methodology. Support to infrared and acoustics-oriented jet simulation will occur.

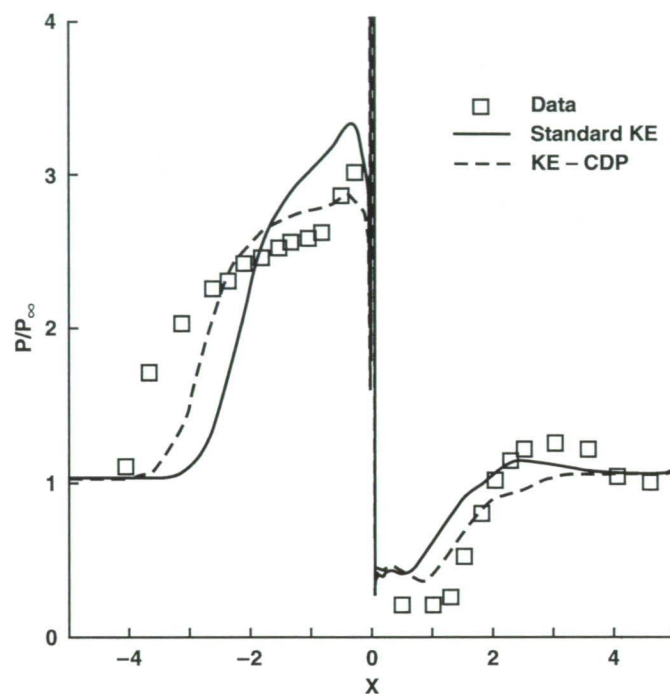

*Improvements provided by the new  $k-\epsilon$  CD model over the  $k-\epsilon$  turbulence model.*

# Three-Dimensional High-Speed Plume/Propulsive Flow-Field Analysis

Sanford M. Dash, Principal Investigator

Co-Investigators: Neeraj Sinha, Brian J. York, Robert A. Lee, Ashvin Hosagadi, and Donald C. Kenzakowski  
Science Applications International Corporation

## Research Objective

To establish a computational methodology for the simulation of steady and transient chemically reacting, multiphase, high-speed plume/propulsive flow fields. Advanced turbulence models are utilized and new techniques for simulating nonequilibrium thermochemical and multiphase processes are being developed.

## Approach

The PARCH time-asymptotic Navier–Stokes code using matrix-split/loosely coupled thermochemistry and the CRAFT time-accurate Navier–Stokes code utilizing large-matrix/strongly coupled thermochemistry are implemented. Specialized versions have been developed for different applications. Complex three-dimensional configurations have been analyzed simulating scramjet propulsive flow fields, rocket propulsive flow fields, and missile–plume interactions (both steady and transient).

## Accomplishment Description

PARCH was utilized to simulate missile flow fields from nose to plume farfield for single- and multi-engine boosters with afterburning chemistry and multiphase flow. A new upwind/implicit finite-volume particle solver was developed and incorporated into CRAFT for simulation of transient plume effects. The particle solution included variable particle properties, different particle types (AL2O<sub>3</sub> and ZrO<sub>2</sub>), and phase change. Detailed studies of transient lateral multiphase plumes have been performed. New compressibility upgraded turbulence models have been incorporated into these codes. Each run requires 20–100 megawords of memory and 10–50 Cray-2 hours depending on the grid dimensions and number of chemical species included.

## Significance

PARCH and CRAFT are the only codes to analyze three-dimensional combusting multiphase flows using advanced implicit numerics and improved two-equation turbulence models with compressible-dissipation and pressure-dilation terms.

## Future Plans

Further work on multiphase flow will include upgrading the Roe/total-variation-diminishing schemes methodology to include liquid equations of state. Applications to hypervelocity launcher problems with dynamic adaptive gridding will be performed.

## Publications

1. York, J. J.; Sinha, N.; Kenzakowski, D. C.; and Dash, S. M. "PARCH Code Simulation of Tactical Missile Plumes/Airframe/Launcher Interactions." CPIA Pub. 568, 19th JANNAF Exhaust Plume Technology Meeting, May 1991.
2. Hosangadi, A.; Sinha, N.; and Dash, S. M. "Solution of Two-Phase Diluted Gas Particle Mixtures Using Upwind Finite-Volume Methodology." AIAA Paper 92-0244, AIAA 30th Aerospace Sciences Meeting, Reno, NV, Jan. 1992.
3. Sinha, N.; Dash, S. M.; and Hosangadi, A. "Applications of an Implicit, Upwind NS Code, CRAFT, to Steady/Unsteady Reacting, Multi-Phase Jet/Plume Flow Fields." AIAA Paper 92-0837, AIAA 30th Aerospace Sciences Meeting, Reno, NV, Jan. 1992.



*Gas-phase and particle-cloud temperature contours at several times during jet injection.*

# Hydrodynamic Performance Evaluation

Donald W. Davis, Principal Investigator  
Co-Investigator: Keith C. Kaufman  
General Dynamics, Electric Boat Division

## Research Objective

To investigate and quantify the effects of Reynolds number scaling on cross-flow separation over unappended bodies of revolution at nonzero yaw angles using Reynolds-averaged Navier–Stokes (RANS) techniques.

## Approach

A three-dimensional steady-state incompressible RANS solver based on the method of pseudo-compressibility, and utilizing centered finite differences together with an alternating-direction implicit/approximate factorization algorithm, was used to perform the first set of computations. An algebraic Boussinesq turbulence model (Briley–MacDonald–Fish) was used. The flow domain was modeled using a multiblock hybrid grid topology that eliminated the appearance of pole-type boundaries. Computations at the lower Reynolds numbers are to be compared with available experimental data. Computations at the higher Reynolds numbers are to be compared with predictions from semi-empirical and singularity based techniques in an effort to validate and enhance these less costly methods.

## Accomplishment Description

The low-Reynolds-number laminar flow around a sphere was used to test the hybrid grid topology. Turbulent-flow computations for two Reynolds numbers (4,900,000 and 13,000,000) were completed for a lift/drag of 9.5 body of revolution at an

angle of yaw of 15 degrees. These computations were performed on an eight block computational grid (totaling 814,200 grid points) which modeled half of the symmetric physical domain. A typical solution required 5.5 Cray Y-MP hours and approximately 7 megawords of memory. Comparisons with experimental results have shown good correlation with body-separation patterns and with the size and extent of the leeside cross-flow vortex.

## Significance

Geometry input simulators that reliably and efficiently predict maneuvering performance under all operating conditions are needed to achieve optimal designs. Accurate hydrodynamic representations of geometry forces and moments are required. Full-scale predictions of complex flow structures will help to improve the understanding of high-Reynolds-number incompressible flows, contributing to advanced design concepts, improved performance, and increased operating envelopes.

## Future Plans

The analyses for two additional Reynolds numbers ( $1.0 \times 10^8$  and  $1.1 \times 10^9$ ) will be completed. Future objectives are focused on extending this effort by including more sophisticated turbulence models and by investigating the viability of and techniques for including the effects of laminar-turbulent transition for the model-scale Reynolds number calculations.

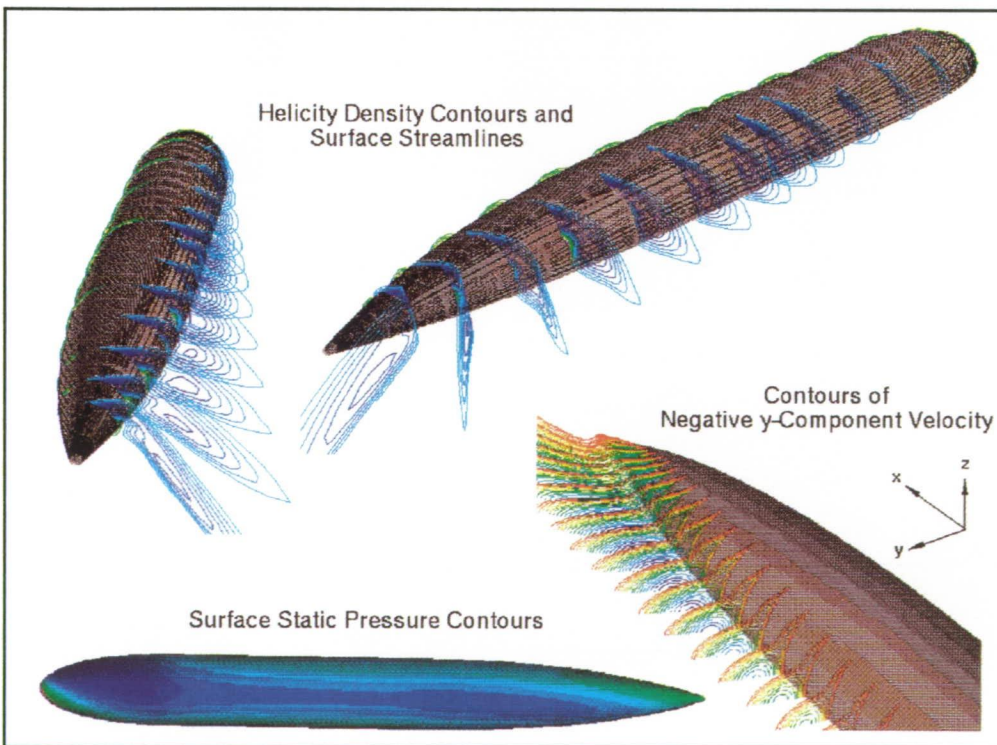

*Reynolds-averaged Navier–Stokes predictions for lift/drag of 9.5, body at 15 degrees yaw angle, and Reynolds number  $1.3 \times 10^7$ .*

# Turbine "Hot Spot" Alleviation using Film Cooling

Roger L. Davis, Principal Investigator  
Co-Investigator: Daniel J. Dorney  
United Technologies Research Center

## Research Objective

To simulate the migration of a three-dimensional combustor hot streak in the flow of an axial turbine stage and to predict its impact, as well as that of rotor surface film cooling and heat transfer, on the rotor time-averaged surface temperature distribution.

## Approach

An extended version of the unsteady three-dimensional Navier-Stokes code, ROTOR3, is used to simulate three-dimensional viscous flows in axial turbomachinery. This approach is a third-order accurate, upwind, approximately factored, implicit finite-difference procedure. Boundary condition modifications have been made to allow for film cooling and heat transfer.

## Accomplishment Description

A three-dimensional unsteady simulation of hot-streak migration in a turbine stage with turbine rotor-surface heat transfer and film cooling has been completed. The film cooling parameters were chosen to be representative of those used in modern gas turbine engines. The placement of the film cooling holes was determined by performing numerous two- and three-dimensional simulations. The addition of film cooling effectively alleviates

the rotor pressure surface temperature increase associated with the combustor hot streak. An average run in this study required 50 Cray Y-MP hours and 16 megawords of memory for one rotor-blade-passing cycle.

## Significance

The research resulted in the development of a numerical procedure that can accurately predict the impact of combustor hot streaks on turbine-blade heat transfer and the film-cooling requirements necessary to keep surface temperatures below critical levels, thus leading to turbine blade designs with increased durability.

## Future Plans

The three-dimensional Navier-Stokes analysis will be used to optimize the film-cooling distribution for a high-pressure turbine blade representative of those used in advanced military aircraft engines.

## Publication

Dorney, D. J. and Davis, R. L. "Numerical Simulation of Turbine 'Hot Spot' Alleviation using Film Cooling." AIAA Paper 92-3309, 28th AIAA/ASME/ASEE Joint Propulsion Conference, Nashville, TN, July 1992.

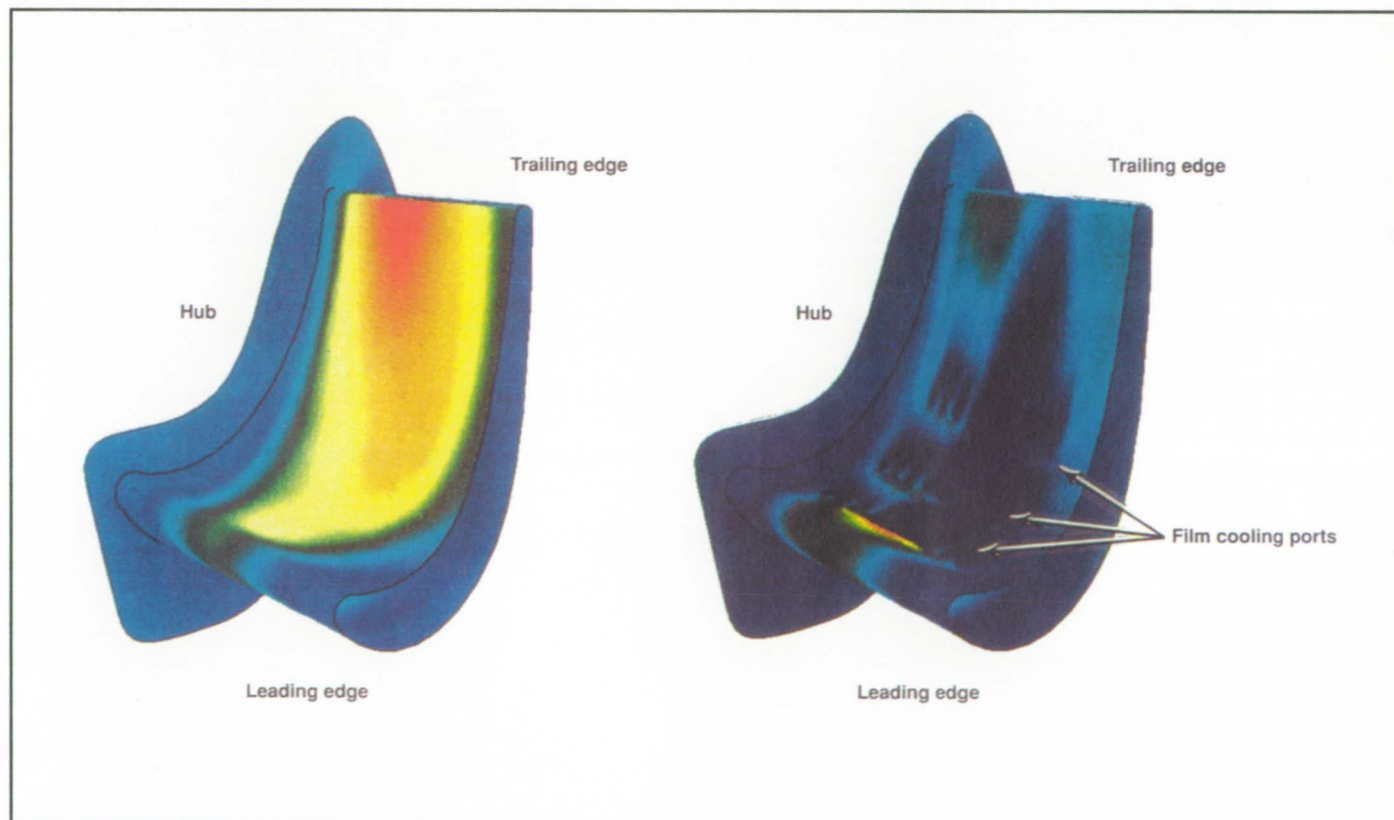

Rotor pressure surface time-averaged temperature contours (a) without film cooling and (b) with film cooling.

# Transition over a Rough Surface

Russell G. DeAnna, Principal Investigator

Co-Investigator: Eli Reshotko

U.S. Army Propulsion Directorate, AVSCOM/Case Western Reserve University

## Research Objective

To predict surface stress and heat transfer coefficients and estimate transition location in order to create improved turbine airfoil designs. Turbine blade surfaces become rough after extensive operation due to high temperature and combustion products. This increases skin friction and heat transfer and promotes transition between laminar and turbulent boundary-layer flow. Delaying or estimating transition is important since we expect higher friction and heat transfer in transitional and turbulent boundary layers.

## Approach

To gain an understanding of the complex features associated with transition over a rough surface by performing a direct numerical simulation using a spectral-element method. A smooth wall is distorted in a random manner and periodic boundary conditions are applied in the horizontal directions, effectively simulating an infinite boundary layer in the streamwise and spanwise directions. Thus, the boundary layer does not grow downstream and parallel flow is assumed.

## Accomplishment Description

At time equal to zero, a Blasius velocity profile is applied to the entire domain. Since the periodic boundary conditions preclude a pressure gradient, the flow is sustained by a body force designed to yield a Blasius profile in the absence of surface roughness. Hence, any vertical or spanwise motion is due to the roughness. The streamwise vorticity indicated in the accompanying figure is due to the rough surface since a smooth boundary layer contains only spanwise vorticity. The code requires 6 megawords of memory when a  $9 \times 5 \times 5$  mesh is used with each element. The time required depends on the information desired. In unsteady flows where turbulent quantities such as Reynolds stresses are required, the code must run for tens of "convection" cycles for a particle to cross the domain. One cycle requires approximately 100 Cray Y-MP hours.

## Significance

This random-roughness calculation represents a first step toward understanding the transitioning boundary layer over a random surface shape. Hopefully, these ideas will be extended by other researchers so that we will gain a better understanding of the complex mechanisms associated with transitional, and ultimately turbulent, flow over surface roughness.

## Future Plans

A grid-resolution study will be done to ensure that numerical turbulence is not being generated. Further data will be obtained so that unsteady frequency response curves and turbulent quantities may be accurately obtained.

## Publication

DeAnna, R. G. and Reshotko, E. "Laminar Flows over Distributed Surface Roughness." Forth International Symposium on Computational Fluid Dynamics, Davis, CA, Sept. 1991.

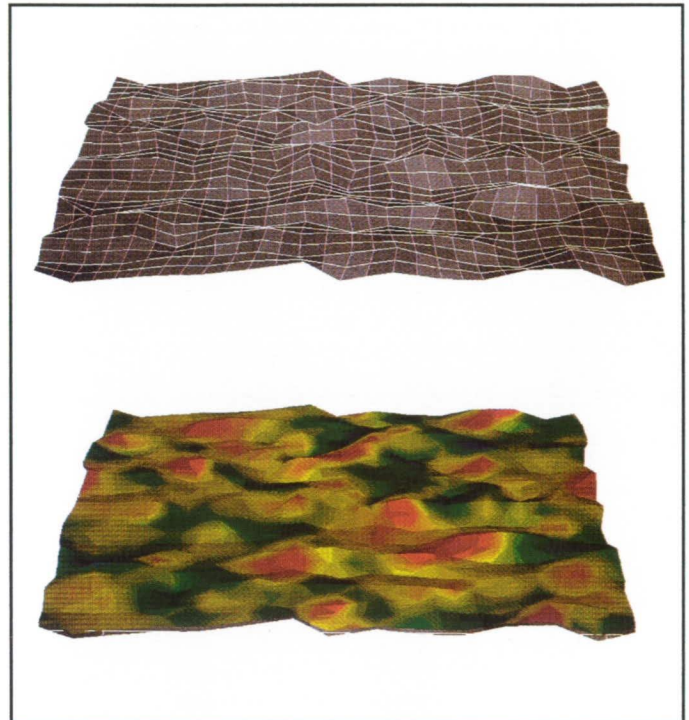

(a) Grid for random surface roughness. (b) Instantaneous streamwise vorticity contours on a horizontal plane at a displacement-thickness Reynolds number of 150 or a roughness height-based Reynolds number of 30.

# Flow about Almost Complete Aircraft and Hypersonic Configurations

Jerry E. Deese, Principal Investigator

Co-Investigators: Ramesh K. Agarwal, Thomas P. Gielda, Jerry G. Johnson, and Mark Axe  
McDonnell Douglas Research Laboratories/NASA Ames Research Center

## Research Objective

To develop computational methods capable of predicting the flow field over a complete aircraft at subsonic to hypersonic speeds, including chemical kinetics effects.

## Approach

The Reynolds-averaged Navier–Stokes equations are solved on body-conforming curvilinear grids using a finite-volume Runge–Kutta time-stepping scheme. Thin-layer, slender-layer, and full Navier–Stokes options are available. A multiblock zonal implementation allows complex configurations to be easily modeled. Algebraic,  $k-\epsilon$ , and Johnson–King turbulence models are available. Equilibrium air, hydrogen–oxygen, and hydrocarbon chemical kinetics models are included.

## Accomplishment Description

Navier–Stokes solutions have been computed for wing–body and wing–body–winglet configurations. Inviscid calculations for a model in a wind tunnel have been performed with porous and solid wall-boundary conditions and compared with experimental data and free-flight predictions. The flow fields over typical launch vehicle configurations have been studied with Baldwin–Lomax,  $k-\epsilon$ , and Johnson–King turbulence models to determine the accuracy of these models for flows including separation. Inviscid solutions for a launch vehicle with nine boosters have been computed; the pressure distribution over this configuration is shown in the accompanying figure. Predictions for a Delta/Thor launch vehicle with plumes, a complete single-stage rocket configuration, and the Aeroassist Flight Experiment vehicle required analysis using the nonequilibrium chemistry capabilities of the code. Calculations for the more complex configurations required as much as 64 megawords of memory and 10 CPU hours.

## Significance

Development of a multizone nonequilibrium chemistry Navier–Stokes code allows the prediction of the flow about complete configurations. Component integration effects can be analyzed, thus enabling configuration designers to optimize the aerodynamic configuration of complete vehicles.

## Future Plans

Multigrid capability is being incorporated into the code. The resulting code will be capable of rapid and efficient analysis of complex configurations.

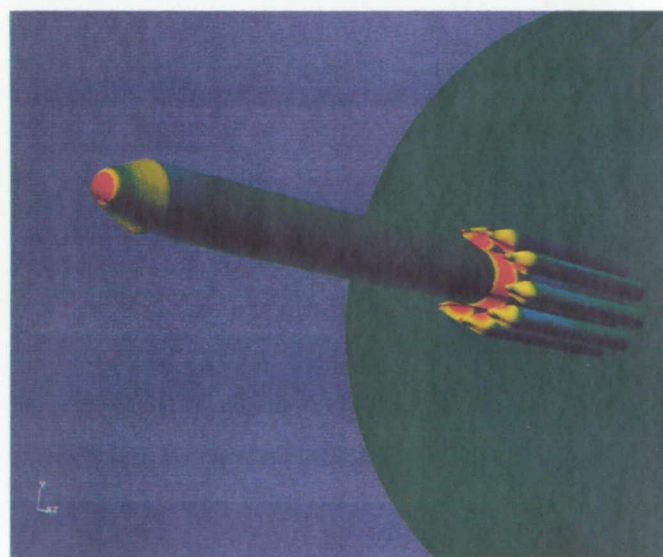
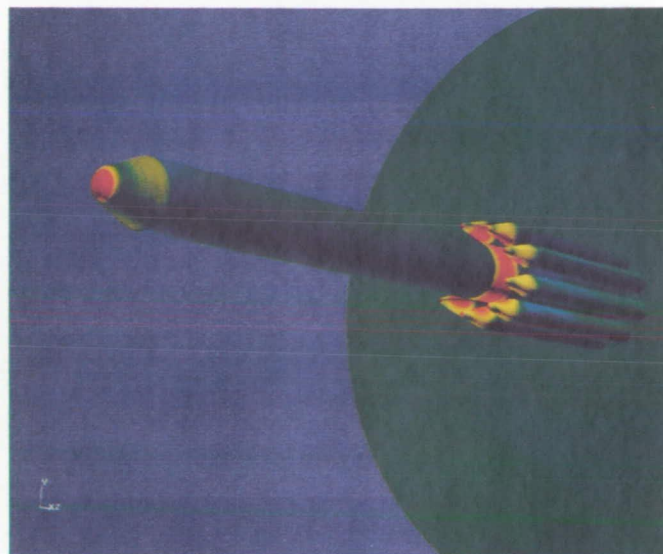

*Surface pressure distribution on a launch vehicle with nine boosters.*

# Sensitivity of Turbulence to Initial Conditions

Robert G. Deissler, Principal Investigator  
Co-Investigator: Frank B. Molls  
NASA Lewis Research Center

## Research Objective

To determine whether sensitive dependence on initial conditions (chaos) is a characteristic of decaying turbulence rather than a characteristic of the numerical method used.

## Approach

To rule out spurious chaos, we investigated the effect of numerical resolution on the chaos.

## Accomplishment Description

To better characterize turbulence, numerical solutions of the unaveraged Navier–Stokes equations were obtained using the Cray-2. A small change in initial conditions completely changes the values of the instantaneous velocity components a short time later. Initial conditions are a characteristic of decaying and forced turbulence. The research results are shown in the accompanying figure, where  $u_1$  is a component of the velocity fluctuation at the numerical grid center, and, at time  $t$ ,  $u_0$  is the initial velocity fluctuation. The overbar indicates a space average,  $\nu$  is the kinematic viscosity, and  $x_0$  is the initial scale of the fluctuations. The effect of spatial resolution on the flow sensitivity to small changes in initial conditions can be seen by comparing the initially perturbed (dashed) curves to the unperturbed (solid) curves. We take, as a measure of that sensitivity, the value of  $x_0^*$ , where a perturbed solution first shows a definite break with the unperturbed solution (incipient breakaway). It is clear that improved resolution increases the sensitivity of the solution to small initial-condition changes. The perturbed solution breaks away from the unperturbed one sooner for the more highly resolved cases with more grid points. Similar results were obtained for other velocity components and at other grid points.

## Significance

The results indicate that the chaos observed in our numerical solutions is not spurious.

## Future Plans

We will continue to investigate the physics of turbulence by obtaining and interpreting numerical solutions of the Navier–Stokes equations for homogeneous turbulence with and without mean gradients.

## Publications

1. Deissler, R. G. "Is Navier–Stokes Turbulence Chaotic?" *Phys. Fluids* 29, no. 5 (1986): 1453–1457.
2. Deissler, R. G. "Effect of Spatial Resolution on Apparent Sensitivity to Initial Conditions of a Decaying Flow as it Becomes Turbulent." *J. Computational Phys.* 100, no. 2 (1992): 430–432.

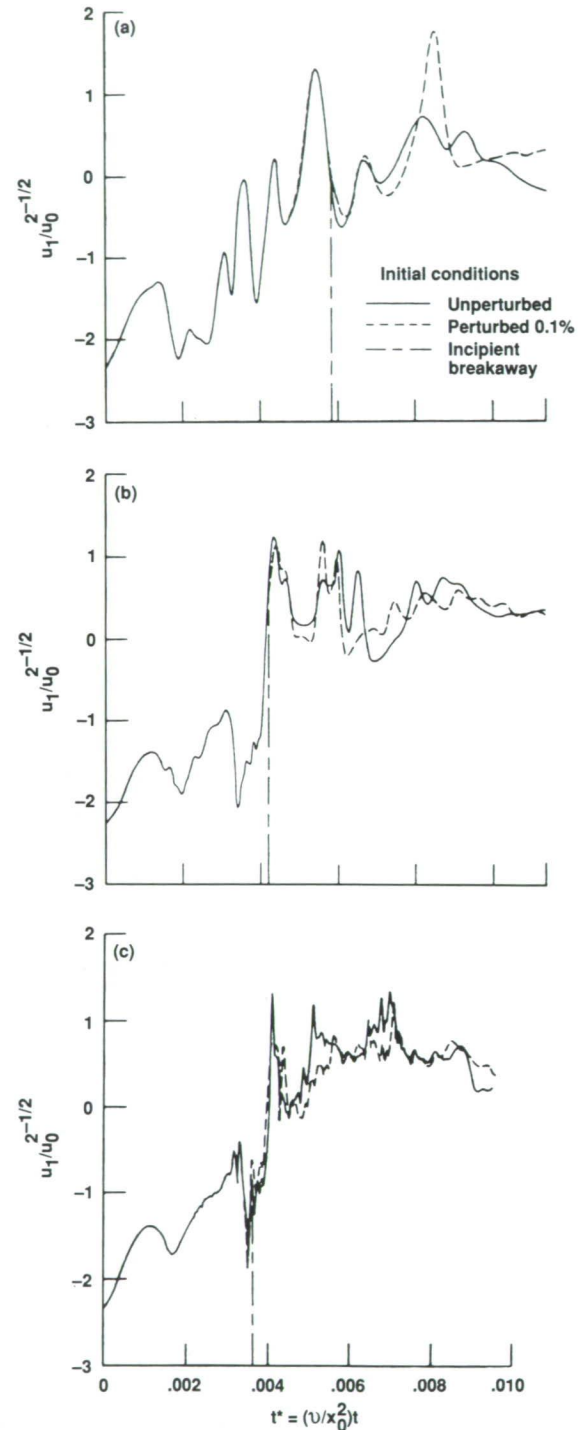

Calculated evolution of velocity fluctuations at grid center (normalized by initial conditions) for initial Reynolds number  $(\overline{u_0^2})^{1/2} x_0/\nu = 1108$ . Root mean-square fluctuations are spatially averaged; (a) 32<sup>3</sup> grid points, (b) 64<sup>3</sup> grid points, and (c) 128<sup>3</sup> grid points.

# Self-Adaptive Grid Code Applied to Complex Three-Dimensional Flows

G. S. Deiwert, Principal Investigator

Co-Investigators: Carol B. Davies and Ethiraj Venkatapathy

NASA Ames Research Center/Sterling Software/Eloret Institute

## Research Objective

To develop a three-dimensional adaptive grid capability that will improve the accuracy and efficiency of computational fluid dynamics (CFD) flow-field calculations.

## Approach

The self-adaptive grid code (SAGE) is applied to the initial grid after a CFD flow solver has computed an interim flow solution. SAGE adapts the grid to the solution by redistributing the grid points into high gradient regions, thus reducing the solution error. The interim flow solution is transferred onto the adapted grid and new files are created for input to the flow solver. The adaption procedure is based on a line by line grid-point-error equi-distribution scheme. Grid smoothness is maintained by applying torsional constraints between adjacent lines in the appropriate computational coordinate directions.

## Accomplishment Description

The successful two-dimensional version of the adaptive grid code was extended to explore the complexities of three-dimensional flow problems. Since three-dimensional flow structures need not be aligned to the initial grid, the ability to choose one-, two-, or three-directional adaptations in any order, make the code a powerful tool in obtaining the most appropriate grid adaption. Extensive use in a wide variety of three-dimensional problems proved the code to be reliable, robust, and effective. An example of a grid adaption for a generic hypersonic aerospace plane is shown in the accompanying figure. The initial grid (with equally distributed grid points) has been adapted with respect to the Mach gradients computed from the flow solution. The figure shows two views of the adapted grid: the cross plane and the symmetry plane. The clustering of points in the shock region can be clearly seen. A typical adaption takes up to 12 megawords of memory and 5 Cray Y-MP minutes.

## Significance

The SAGE code improves the accuracy of flow solutions. The line-by-line marching approach uses little computer time in comparison to the flow solver.

## Future Plans

To fully analyze flow around complex structures, grids are frequently generated in multiple grid format. The SAGE code adapts single grids only; any matching of grids at common interfaces must be handled independently. The next upgrade to SAGE will include an internal grid transfer capability.

## Publications

1. Davies, C. B. and Venkatapathy, E. "Application of a Solution-Adaptive Grid Scheme, SAGE, to Complex Three-Dimensional Flows." AIAA Paper 91-1594, June 1991.
2. Davies, C. B. and Venkatapathy, E. "The Multidimensional Self-Adaptive Grid Code, SAGE." NASA TM-103905, 1992.

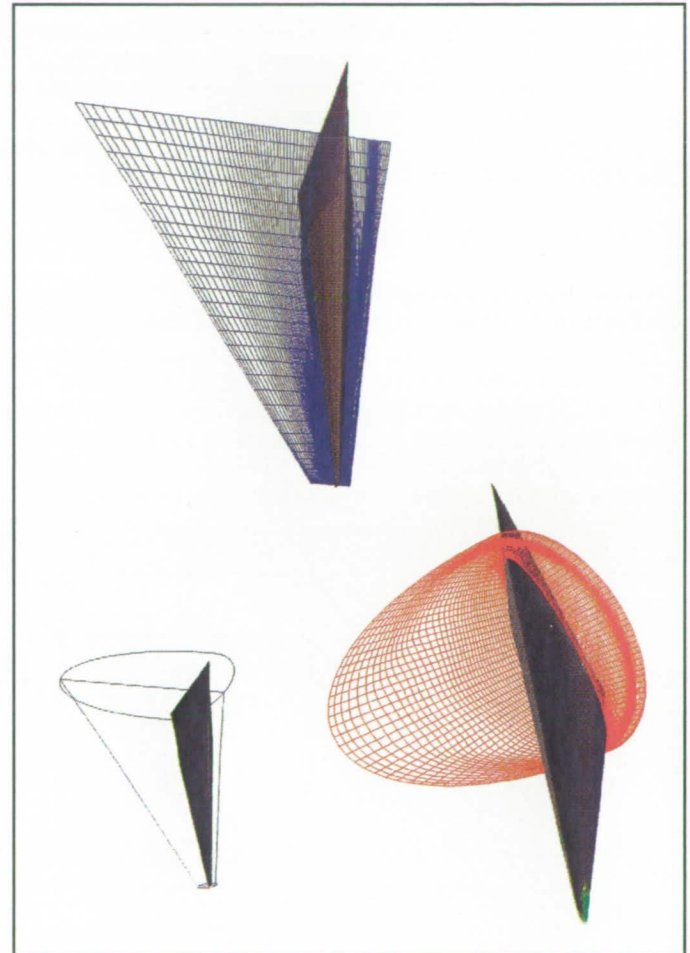

*Adaptive grid for a generic aerospace plane; (a) computational domain, (b) adaptive grid in symmetry plane, and (c) adapted grid in cross plane.*

# Complex Three-Dimensional Turbulent Flows

A. O. Demuren, Principal Investigator  
Old Dominion University

## Research Objective

To develop accurate computational procedures for the analysis of complex three-dimensional turbulent flows with applications for ducts, jets, and turbomachinery.

## Approach

The technical approach is to solve Reynolds-averaged Navier–Stokes equations and the continuity and energy equations with a computer code based on the finite-volume method. Turbulent stresses and fluxes that result from the averaging process are approximated with second-moment closure models. Conventional numerical methods usually suffer from deterioration in the convergence rates as computational grids are refined for improved accuracy. To overcome this shortcoming in the study, multigrid techniques are utilized to achieve grid-independent convergence rates.

## Accomplishment Description

It has been possible to make computations of three-dimensional flows on very fine grids up to 2 million points using multigrid methods for convergence acceleration and Reynolds stress turbulence models for improved realism. Quite promising results have been obtained in a number of practical, useful flows such as jets in cross flow, impinging jets, and transition duct flows. An average job required about 20 megawords of memory and 1 single processor Cray-2 hour.

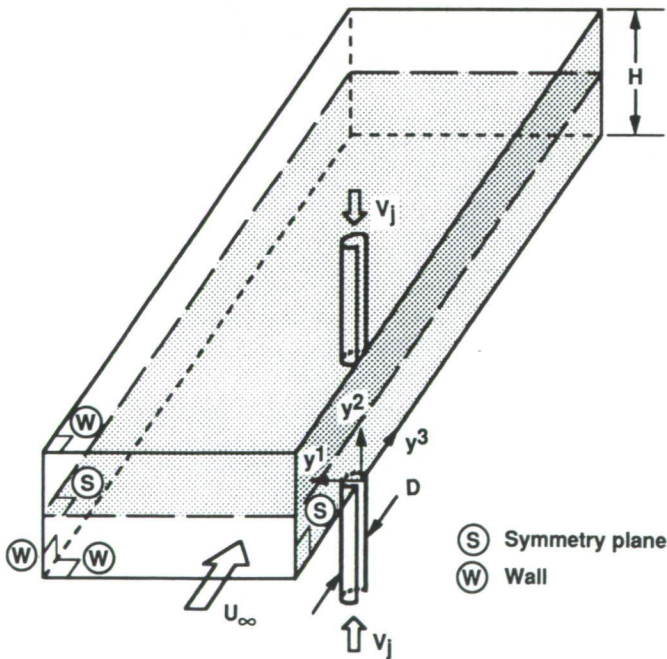

Pair of opposed jets in cross flow.

## Significance

We are close to having a general purpose three-dimensional flow solver with state of the art turbulence models that enable computations of important flows on refined grids within reasonable CPU times. The code can also be used as a test bed for the development of turbulence models.

## Future Plans

To complete the development and testing of the code. At a later date, the code will be parallelized.

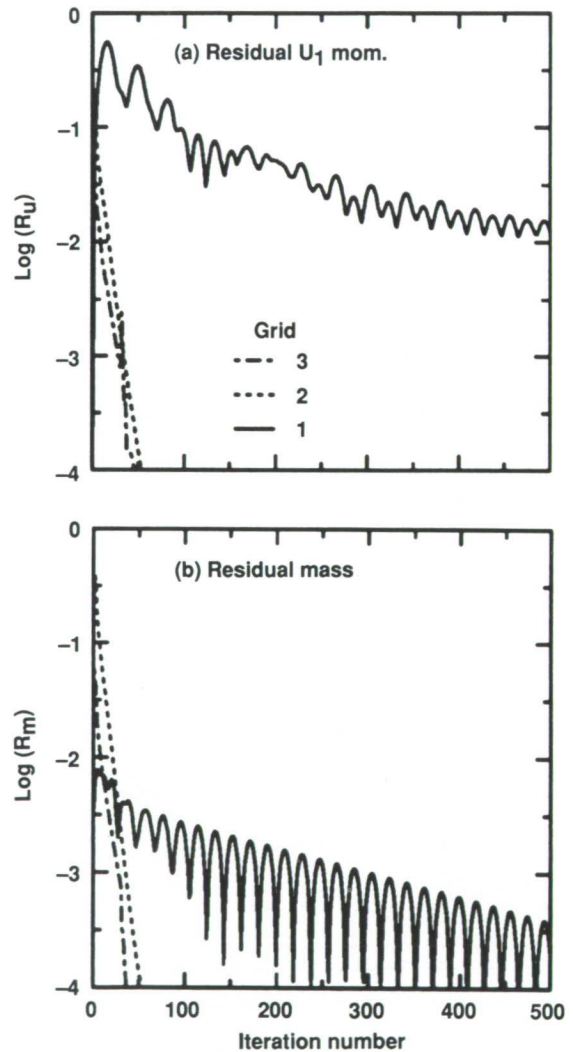

Multigrid convergence acceleration for a laminar jet in cross flow.

# Rarefied Hypersonic Condition Wake Structures

Virendra K. Dogra, Principal Investigator

Co-Investigators: Richard G. Wilmoth, James N. Moss, and Joseph M. Price

ViGYAN, Inc./NASA Langley Research Center

## Research Objective

To examine the basic feature of wake flows under rarefied hypersonic conditions and to provide a basis for establishing guidance as to when the continuum description becomes inappropriate for such flows. Precise determination of wake closure is a critical issue for aerobrake design. At typical perigees of 70–80 km, the local Knudsen numbers near separation are of the order of 0.1 or larger. For such conditions, the continuum description becomes suspect, and at higher altitudes the continuum description is invalid.

## Approach

The direct simulation Monte Carlo (DSMC) method was used to simulate the flow about spheres for flow conditions that had been previously obtained in low-density wind tunnels. The DSMC approach is the only practical approach for simulating the complex physics of rarefied flows.

## Accomplishment Description

DSMC simulations were made for six wind tunnel conditions at Mach 12 where the free-stream Knudsen number (length based on sphere diameter,  $d$ ) ranged from 0.8 to 0.009. For these conditions, the calculated and measured drag coefficients ( $C_D$ ) agree to within 4%, which is well within the experimental error.

As for the wake structure, the DSMC calculations show no evidence of separation in the wake, whereas a continuum solution has predicted incipient separation with a well defined recirculation zone. The wind tunnel case with a Knudsen number of 0.009 was simulated using 170,000 modeled molecules and 7,225 cells. The computation required approximately 40 Cray Y-MP hours and 3 megawords of memory.

## Significance

This study demonstrates the ability of the DSMC method to simulate hypersonic rarefied flows where continuum conditions may dominate the forebody flow (the overall drag) and yet the rarefaction effects are clearly dominant in the wake. This study provides a data base for assessing the bounds for which Navier–Stokes solutions are applicable for assessing the nature of wake flows for Aeroassisted Space Transfer Vehicles (ASTV).

## Future Plans

The study will be expanded to examine the wake flows resulting from hypersonic flow about blunted cone shapes that are more representative of ASTV configurations. Also, the effect of stings and payloads on the wake flow will be examined. Hopefully, comparisons with wind tunnel measurements of wake flow structure can be made.

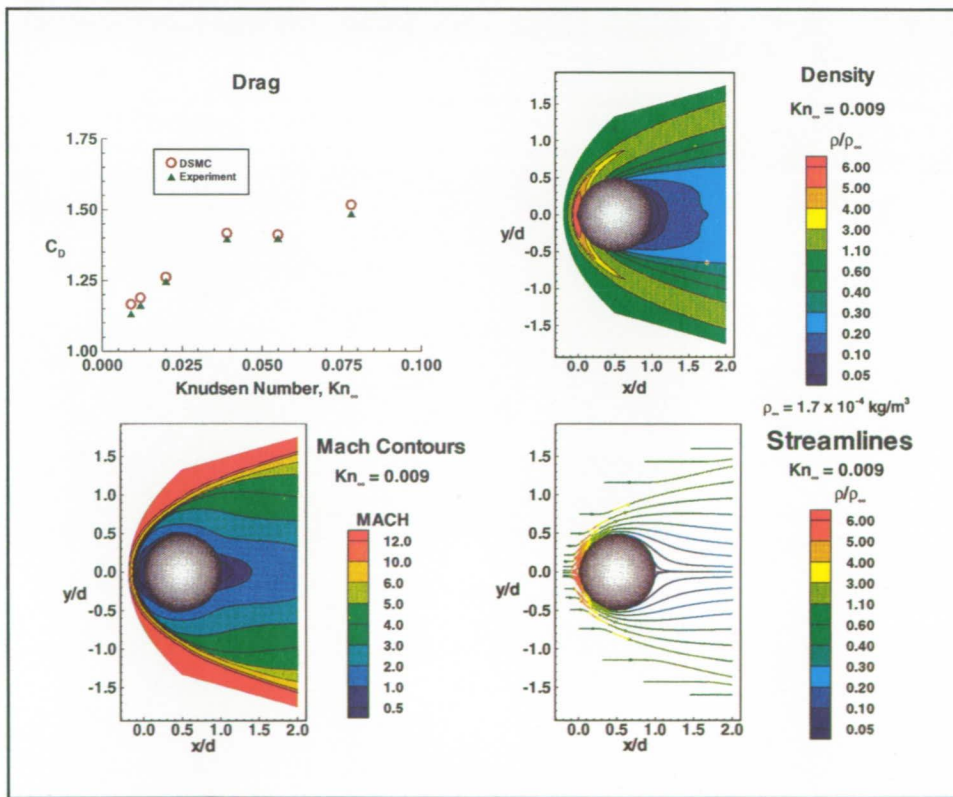

Direct simulation Monte Carlo calculations for a 2 cm diameter sphere at Mach 12.9 nitrogen flow and a wall temperature of 600 K.

# Fuel–Air Mixing Enhancement by Jet–Shock Interactions

J. Philip Drummond, Principal Investigator

Co-Investigators: Peyman Givi, Cyrus K. Madnia, and Craig J. Steinberger

NASA Langley Research Center

## Research Objective

To study phenomena that control high-speed fuel–air mixing, and to use information gained from these studies to improve mixing and combustion efficiency in high-speed propulsion devices.

## Approach

To solve, using an accurate numerical algorithm, the equations governing the mixing and chemical reaction of a multicomponent mixture in combination with physically realistic chemical kinetics models to describe combustion processes.

## Accomplishment Description

A computer program was developed that solves the equations governing a multicomponent mixing and reacting flow. The code was validated against experiments involving nonreacting and reacting flow fields, and then applied in studies of combustor high-speed engine flows. Recent research has been directed toward the optimization of a scramjet combustor and the efficiency of fuel–air mixing and reaction in the engine. Mixing is significantly reduced in the engine as the combustor Mach number increases with flight Mach number, and mixing enhancement is required to achieve a sufficient degree of combustion efficiency. Because of this difficulty, alternate combustor fuel-injector configurations were studied to evaluate their potential for producing an improved degree of mixing and reaction. A fuel injector configuration was parametrically studied using the code to improve fuel–air mixing. A typical run required 16 Cray Y-MP hours and 64 megawords of memory. A gaseous hydrogen-fuel jet, co-flowing with air, was processed through a 10 degree oblique shock produced by a wedge. When the low density hydrogen jet passed through the shock, the pressure field and density field became misaligned, bifurcating the jet and producing a vortex pair. Mixing was significantly enhanced and large amounts of water were produced through reaction of the hydrogen and air. The accompanying figure shows the resulting water mass fraction, without and with the shock, in the central streamwise plane and at the final cross plane considered in the study. The shocked jet shows a large cross section of water with a peak mass fraction of 25%. The resulting vortex pair, at the same location, is also shown on the figure. When the hydrogen jet is not processed by the shock, little mixing of fuel and air results, and only a narrow annular ring of water, shown in the figure, is produced with a water peak of 0.6%. So, as can be seen, the fuel injector design results in a significantly larger amount of mixing and a chemical reaction that produces a marked increase in combustion efficiency.

## Significance

Numerical simulations provide an improved insight of the mechanisms controlling high-speed mixing and combustion in supersonic reacting flows. Techniques can be developed for enhancing mixing and reaction in supersonic combustors, thus improving the overall level of combustion efficiency.

## Future Plans

Work is under way to optimize the degree of enhancement that can be achieved from the fuel-injector configuration. Other injector configurations that utilize swirl or alternate fuel-nozzle designs for enhancement will also be examined.

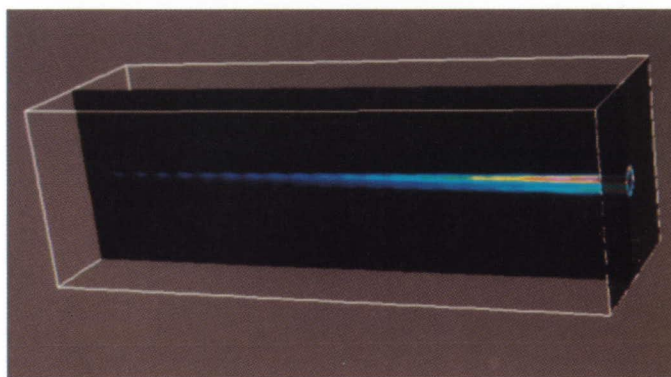

*Unshocked hydrogen-fuel jet.*

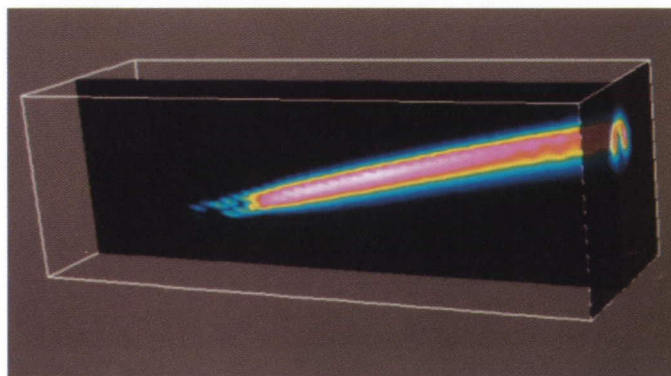

*Shocked hydrogen-fuel jet.*

# Aerobraking Studies of Three-Dimensional Nonequilibrium Viscous Flow

C. T. Edquist, Principal Investigator  
Co-Investigator: T. J. Galambos  
Martin Marietta Astronautics Group

## Research Objective

To use a computational fluid dynamics code to examine the aerothermochemical aspects of aerobraking during lunar return missions; validate the selection of aerobrake forebody shapes and sizes and payload configurations; calculate the heating environment experienced by the payload in the base region; and establish a matrix of forebody solutions.

## Approach

We used the Langley Aerothermodynamics Upwind Relaxation Algorithm (LAURA) code which considers all of the aerothermochemical phenomena necessary for detailed consideration of lunar return aerobraking to study a number of possible aerobrake configurations and verify the conclusions arrived at by using less elaborate engineering procedures.

## Accomplishment Description

A series of blunt cone forebody calculations of a lower corridor (high heating) trajectory near peak heating have been made. A 70 degree sphere cone with base and nose radii of 22.5 and 11.25 feet respectively and an aft edge radius of 1 foot was chosen for the reference geometry. An additional forebody configuration was formed by increasing the nose radius to its largest value corresponding to a spherical segment. Three points on a trajectory with ballistic coefficient ( $\beta$ ) of 14 psf were considered and the reference forebody flow field at a 10 degree angle of attack was calculated at each trajectory point. The spherical segment forebody flow field was also calculated at the peak heating altitude. A converged solution required about 20 Cray-2 hours and 40 megawords of memory. Solutions at peak heating for  $\beta$  values 10 and 20 psf were also obtained for the reference body. The effect of edge radius was studied by doubling that radius to 2 feet for both the sphere cone and spherical segment. Results showed general agreement with experiment. The calculated distribution of pressure and convective heating on the Viking forebody compared well with experimental wind tunnel data. Initial wake and payload flow-field calculations were made using a perfect gas version of LAURA to develop an understanding of the flow characteristics.

## Significance

Aerobraking is a cost effective method of capturing a manned or unmanned vehicle on return from the moon or Mars or during a Mars encounter. The benefits of aerobraking will be maximized when the aerothermodynamics of high velocity, high altitude flight in the Earth's or other planetary atmospheres are well understood. Using a code such as LAURA will provide valuable insight for the design of these vehicles.

## Future Plans

We will use the forebody solutions to examine various afterbodies and payload configurations to determine the most

efficient means of protecting the aerobrake cargo. Additionally, Mars entry and return missions will be studied because they require consideration of higher energies and different chemical species and reactions.

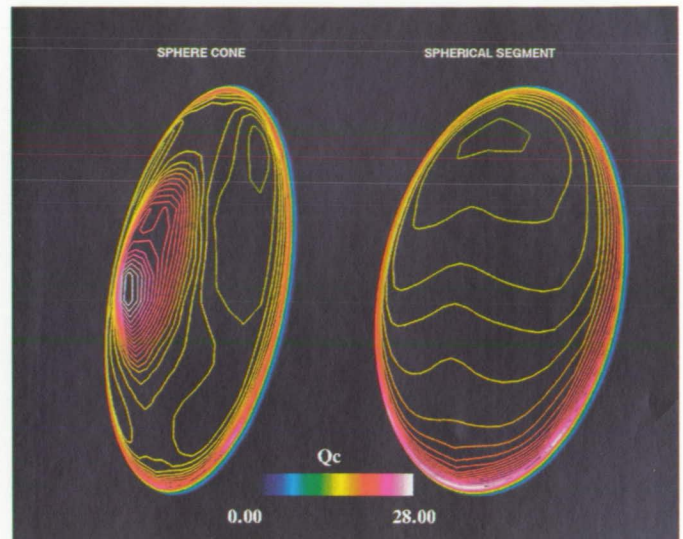

Comparison of forebody convective heating to representative aerobrakes at peak heating during lunar return at a 10 degree angle of attack.

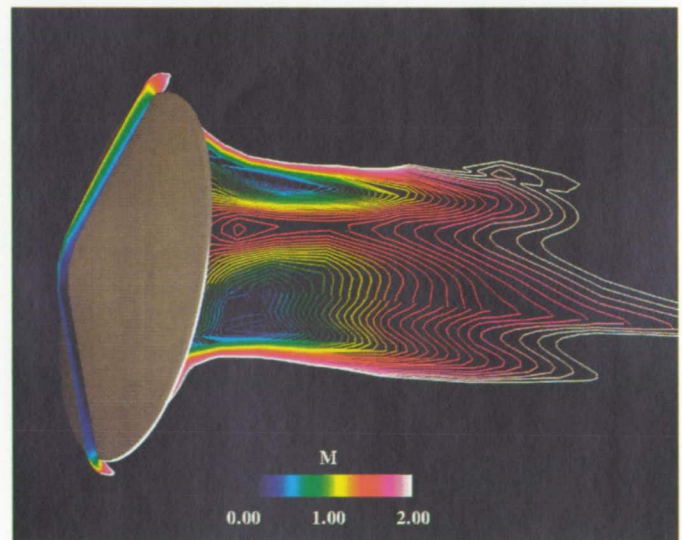

Mach number contours in the plane of symmetry of the Viking aeroshell at Mach 14.9 and an 11.2 degree angle of attack.

# Aerodynamic Optimization of Supersonic Transport Aircraft

Thomas A. Edwards, Principal Investigator  
Co-Investigator: Samson H. Cheung  
NASA Ames Research Center/MCAT Institute

## Research Objective

To develop, validate, and apply computational fluid dynamics (CFD) optimization methods to design supersonic aircraft, focusing on the dual design objectives of low sonic boom and high aerodynamic performance. This research helps define the economic viability of low-sonic-boom aircraft.

## Approach

A numerical optimization routine based on a sequential quadratic programming algorithm was coupled with an implicit Euler/Navier–Stokes solver and a parabolized Euler/Navier–Stokes code. For aerodynamic performance optimization, design parameters such as the wing-twist angle and airfoil camber are used to maximize the lift/drag (L/D) ratio. Sonic-boom minimization uses the equivalent area distribution as the objective function. The optimization procedure uses CFD to compute the equivalent area of the configuration, while the optimizer adjusts the cross-sectional area to achieve more desirable sonic-boom characteristics.

## Accomplishment Description

The sonic-boom minimization and aerodynamic optimization procedures have been developed and validated. The design capability has been applied to a High-Speed Civil Transport (HSCT) concept. The first figure shows that the redesigned aircraft has a 3.75% improvement in L/D. These calculations typically require 10 Cray-2 hours and 16 megawords of memory. To exercise the sonic-boom minimization procedure, a target “flat top” pressure distribution for the sonic boom was specified as the objective function. The original configuration exhibited an N-wave pressure distribution with a small intermediate shock (shown in the second figure). The configuration gives a sonic boom that is much closer to the objective function while still satisfying fuselage size constraints.

## Significance

The methodology and computational tools used in this project provide the capability to design a high-performance, low-boom HSCT configuration prior to fabricating wind tunnel models. This study will help define the economic viability of low-boom airplanes compared to alternative mission profiles. Other cruise conditions, such as takeoff and landing, can also be used as constraints or variables to design an HSCT with complete performance consideration.

## Future Plans

The procedure is being applied to advanced low-boom designs. When the performance of these designs reaches goals identified for L/D and sonic boom, wind tunnel models will be built and tested to validate the results.

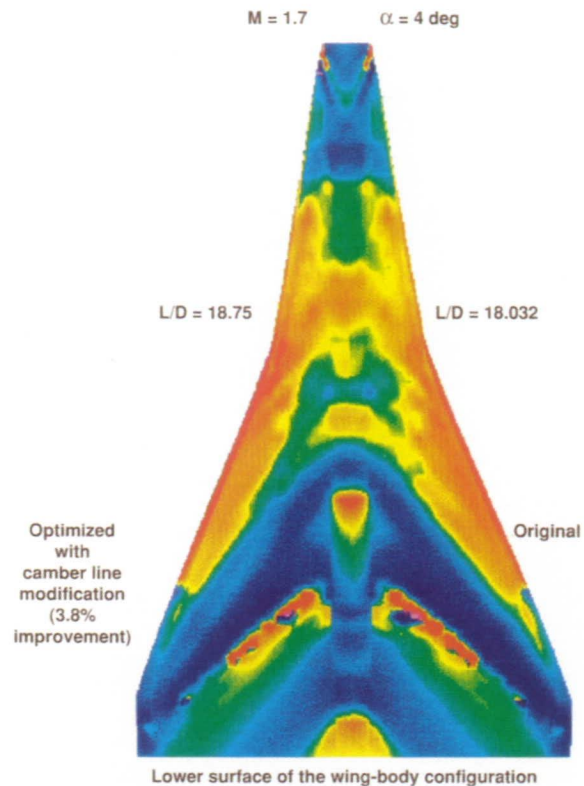

Supersonic wing-body optimization.

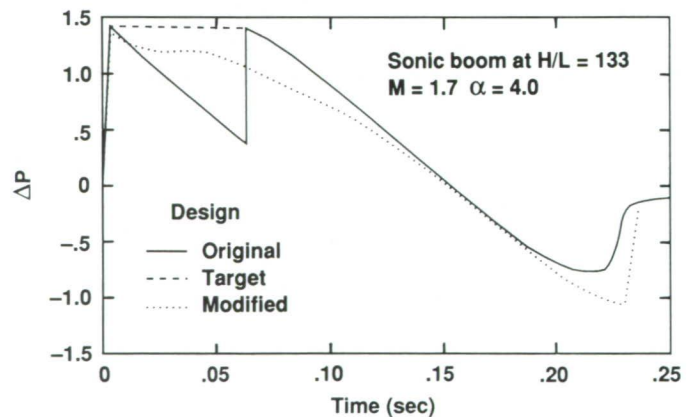

Comparison of sonic booms;  $H/L = 133$ ,  $M = 1.7$ , and  $\alpha = 4.0$ .

# Rotary-Wing Airload Performance Prediction

T. Alan Egolf, Principal Investigator  
Co-Investigator: Brian E. Wake  
United Technologies Research Center

## Research Objective

To develop rotary-wing blade airload and performance prediction capability without reliance on empirical airfoil characteristics to provide a numerical rotor test facility for application to helicopters and high-speed propellers.

## Approach

To refine and enhance advanced helicopter and high-speed propeller computational fluid dynamics (CFD) and wake modeling codes to include more rigorous representations of the rotor wake and provide viscous drag prediction capability, we coupled the methods and incorporated the rotor-wake influence in the CFD codes using velocity embedding techniques and transpiration boundary conditions. The wake influence is based on prescribed wake geometries from analytical, empirical, or numerical predictions. We developed improved wake geometry prediction capabilities based on free-wake vortex-lattice methods and performed validation studies of the component and coupled codes.

## Accomplishment Description

Activity focused on validation of the rotary-wing viscous flow solver (NSR3D) and code refinements for robustness and improved convergence. NSR3D was applied to an initial oscillating-wing geometry for an assessment of the ability of the code to predict unsteady three-dimensional viscous-flow behavior. Initial unsteady predictions show reasonable agreement with test results. The study used 325,000 grid points, requiring approximately 100 Cray Y-MP hours for two cycles of oscillation and about 30 megawords of memory for an average case. In addition to this validation effort, the research was used to support a NASA contract for an acoustic investigation of rotor-tip designs using NSR3D. Over 400,000 grid points and 130 Cray-2 hours (including trimming to the desired rotor thrust level) and 40 megawords of memory were required.

## Significance

Application of NSR3D to geometries and unsteady flow conditions for test data that are available provides an assessment of the code's prediction capabilities.

## Future Plans

Refinements to the solver and the incorporation of the hover wake influence into NSR3D using a refined hover free-wake model are planned.

## Publication

Wake, B. E. and Egolf, T. A. "Initial Validation of an Unsteady Euler/Navier-Stokes Flow Solver for Helicopter-Rotor Airloads in Forward Flight." *American Helicopter Society International Technical Specialists' Meeting on Rotorcraft Research*. Atlanta, GA, Mar. 1991.

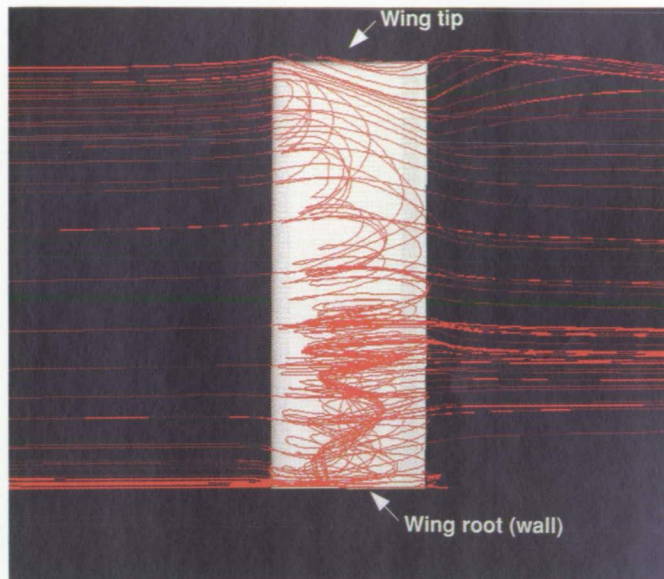

Particle trace illustrating post-stall separated flow behavior of an unsteady wing as predicted by NSR3D.

# Transpiration Cooling for Scramjet Combustor Flow Fields

Dean R. Eklund, Principal Investigator  
National Research Council/NASA Langley Research Center

## Research Objective

To develop the capability to predict the surface heat-transfer rates generated by the turbulent, three-dimensional reacting flow fields occurring within supersonic scramjet combustors. Two intermediate steps are to develop the capability to efficiently model turbulent mixing and finite-rate kinetics within scramjet combustors.

## Approach

A three-dimensional Navier–Stokes code with finite-rate chemistry models has been used to model the internal reacting flow fields.

## Accomplishment Description

The SPARK three-dimensional Navier–Stokes code was validated for nonreacting internal flow fields with transverse injection. A series of calculations of the reacting flow from the transverse injection of hydrogen behind a rearward-facing step into a Mach 2 flow were performed. The effects on the efficiency of the combustor of two geometric parameters, the angle of the expanding portion of the duct and the length of the constant area section, were examined. The calculations revealed that, even at the relatively low flight Mach numbers (5–7) associated with the conditions investigated, the chemical constituents are far from equilibrium and kinetics effects are important. The calculations will be compared to nitrogen temperature and density measurements obtained with a coherent anti-Raman spectroscopy system during a series of future experiments. The accompanying figure shows the calculated temperature contours along the centerline plane of the injector, the bottom wall of the combustor, and four cross-flow planes. Reaction is observed (red contours) in the

recirculating region upstream from the jet and in the mixing region between the injectant and the free stream downstream from the injector. A typical calculation required approximately 30 Cray Y-MP hours and 10 megawords of memory.

## Significance

Prediction of the surface heat-transfer rate and the design of methods to relieve these heating loads is one of the critical technical obstacles in the development of proposed air-breathing propulsion systems for hypersonic flight. The complexity of the three-dimensional, turbulent reacting flow fields within the combustors makes calculations of heat-transfer rates a challenging task. Successful modeling of these flow fields will provide a powerful design tool for these systems and assist in the analysis of their performance.

## Future Plans

Simplified finite-rate chemistry models are being tested in the SPARK Navier–Stokes code. A zonal gridding capability will be incorporated into the SPARK code. Calculations with the General Aerodynamic Simulation Program Navier–Stokes code are also planned to compare the efficiency of the two codes. Finally, the codes will be used to model an experiment to test a transpiration cooling system for perpendicular injection of hydrogen fuel into Mach 2 flow.

## Publication

Eklund, D. R. and Northam, G. B. "A Numerical Study of the Effects of Geometry on the Performance of a Supersonic Combustor." AIAA Paper 92-0624, Jan. 1992.

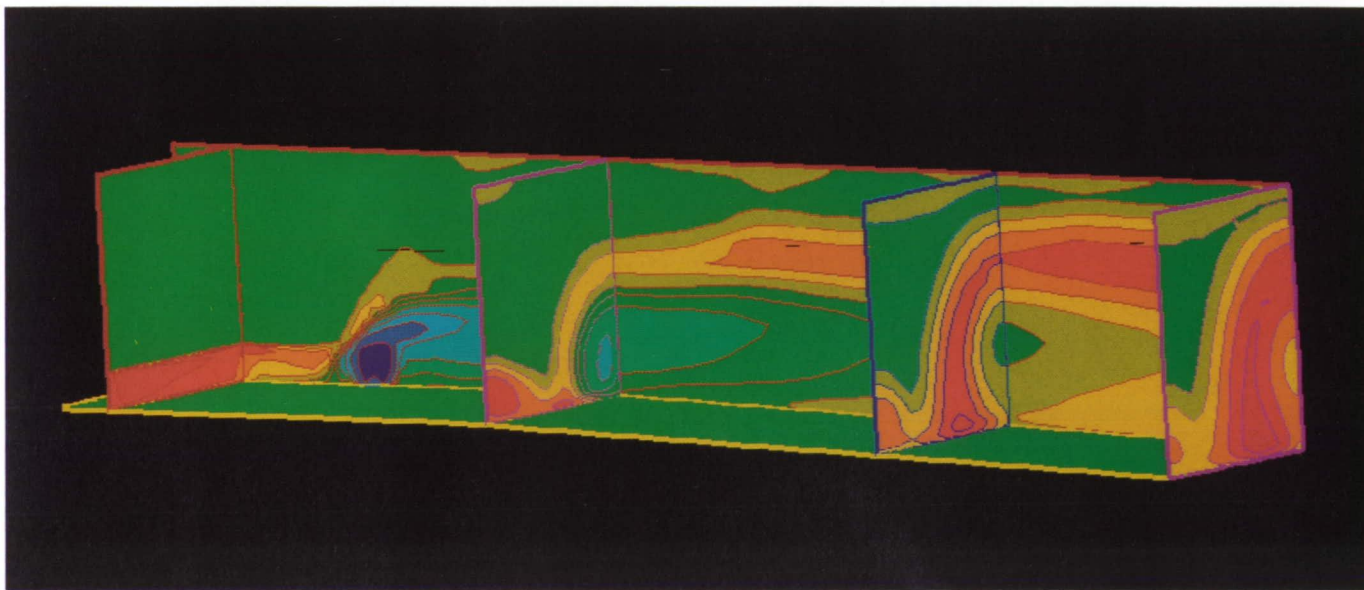

Temperature contours (red = 2,200 K; blue = 200 K) for the normal injection of hydrogen fuel behind a rearward-facing step into a heated Mach 2 airstream. The direction of the airstream is from left to right.

# Flow Solver for Euler Equations on Unstructured Tetrahedral Meshes

Larry L. Erickson, Principal Investigator  
Co-Investigator: M. Jahed Djomehri  
NASA Ames Research Center/Eloret Institute

## Research Objective

To assess and improve unstructured three-dimensional flow solvers and mesh generators for complex aerodynamic shapes at transonic/supersonic speeds (specifically the FELISA code).

## Approach

The method is based on an explicit Taylor–Galerkin weighted residual scheme with local time-stepping for steady computations. The flow field is an assembly of tetrahedral elements generated by an advancing front technique. Variable grid spacing is achieved by user-specified control parameters. The grid can be adapted to flow features, such as density, by the equi-distribution of error concept.

## Accomplishment Description

FELISA was applied to two standard wind tunnel configurations (a low-aspect-ratio wing, and a cone cylinder) used to assess sonic boom signatures. The cone cylinder and its adapted grid are shown in the accompanying figure. The mesh has been adapted to the flow features and consists of 61,299 grid points. The sectional view of the grid on the xy- and xz-symmetry planes and an enlarged view of the body are shown. The main feature of the flow field is an attached weak bow shock at the cone apex and an expansion wave at the intersection of the cone and cylinder. The grid is concentrated in these regions. The residual of the computed solution was dropped three orders of magnitude within 2,000 time iterations. This calculation required 1.5 Cray Y-MP hours and 10 megawords of memory.

More complicated geometries require about 30–40 megawords. Although the geometry is simple, the formation of a smooth grid around the nose of the cone, whose half angle was only 3.6 degrees, was complicated. The surface and volume grid generators were improved to handle these configurations. Computed relative pressure data,  $\Delta P/P_\infty$ , along a line half a cone length away from the body in the free stream flow direction, has been extrapolated to 10 cone lengths away from the body and compared against wind tunnel measurements. The figure contains computed solutions obtained on a multiblock grid by the structured grid solver TEAM. The plot shows pressure signatures due to bow shock and expansion waves. Results appear in agreement near the shock, but differ slightly near the expansion wave. The inconsistency is believed to be due to the coarseness of the grid to the right of the expansion wave.

## Significance

Automated solution-adaptive grid generation for realistic aircraft appears to be possible with this approach and could be a significant step toward making computational fluid dynamics useful to the practicing aerodynamicist.

## Future Plans

Calculations are planned to assess the versatility of the mesh generator and flow solver on further complex three-dimensional problems such as supersonic wing–body and complete Lear-jet configurations.

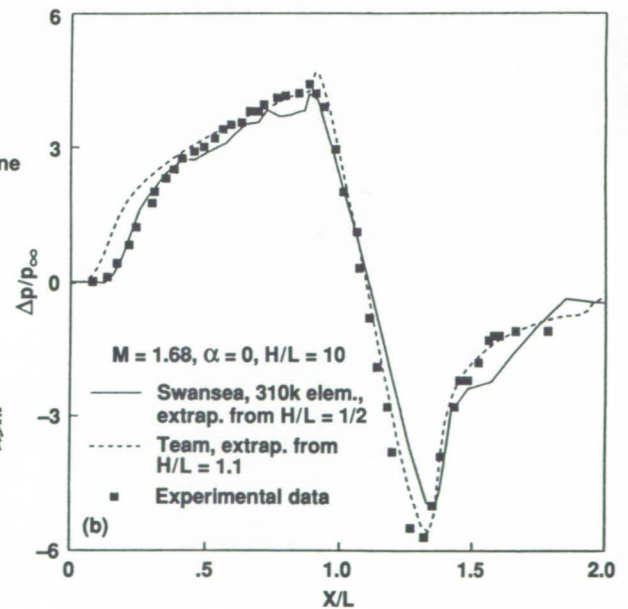
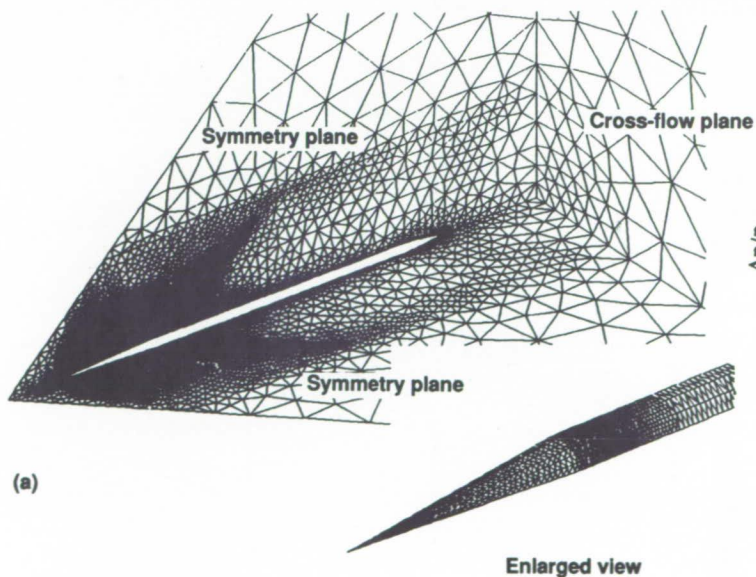

Cone cylinder at  $M_\infty = 1.68$ ;  $\alpha = 0$  degrees; (a) surface and volume grid and (b) off-body pressure signatures.

# Discrete Particle Simulation of Compressible Flow

William J. Feiereisen, Principal Investigator

Co-Investigators: Jeffrey McDonald, Brian Haas, Iain Boyd, Donald Baganoff, Michael Fallavollita,  
Terry Denery, and Avijit Goswami

NASA Ames Research Center/Stanford University

## Research Objective

To develop and validate a new particle-simulation method for rarefied hypersonic flow and its application to realistic three-dimensional geometries, modeling of nonequilibrium thermochemistry, and efficient implementation on supercomputer architectures.

## Approach

Direct particle-simulation methods model a rarefied flow as a large collection of discrete particles which travel and interact through collisions. To improve the direct simulation Monte Carlo technique, new collision selection rules and other algorithmic changes permit efficient implementation of the new methods on vector supercomputers. Unlike previous models, collision models are enhanced to capture coupled vibration-dissociation behavior in high-temperature gases.

## Accomplishment Description

New collision models were developed, accounting for multilevel vibrational quantum transitions and vibrationally favored dissociation rules, that capture essential nonequilibrium thermochemistry. Results agree favorably with experimental data. The code was employed to simulate proposed aerobraking maneuvers of the Magellan spacecraft orbiting Venus. Temperatures and flow-field particles are plotted in the accompanying figure for Mach 35 flow at Knudsen numbers exceeding 0.10 about the complex multibody geometry. New models for surface heat

transfer permit assessment of surface temperatures. The significance of flow-field molecular collisions was evaluated and compared to free molecule flow. Employing 400,000 particles and 44,000 domain cells, each simulation required less than 2 Cray-2 hours and 12 megawords of memory.

## Significance

Computational predictive capability is essential to assess the aerodynamic and thermal environment encountered by atmospheric-entry spacecraft and high-altitude maneuvering vehicles. Direct particle-simulation methods are most appropriate for modeling rarefied flows since computational fluid dynamics based upon continuum Navier-Stokes equations are not applicable. The computational burden and model simplicity of previous methods are improved upon in this work, thus permitting large-scale simulation of flows about geometries of engineering interest.

## Future Plans

Applications will include studies of rarefied turbulence and Magellan aerobraking at various angles of attack. Models will be enhanced for vibrational kinetics and for particle-surface interaction. Methodologies to extend the simulation application into the near-continuum flow regime with minimal computational penalty will be investigated.

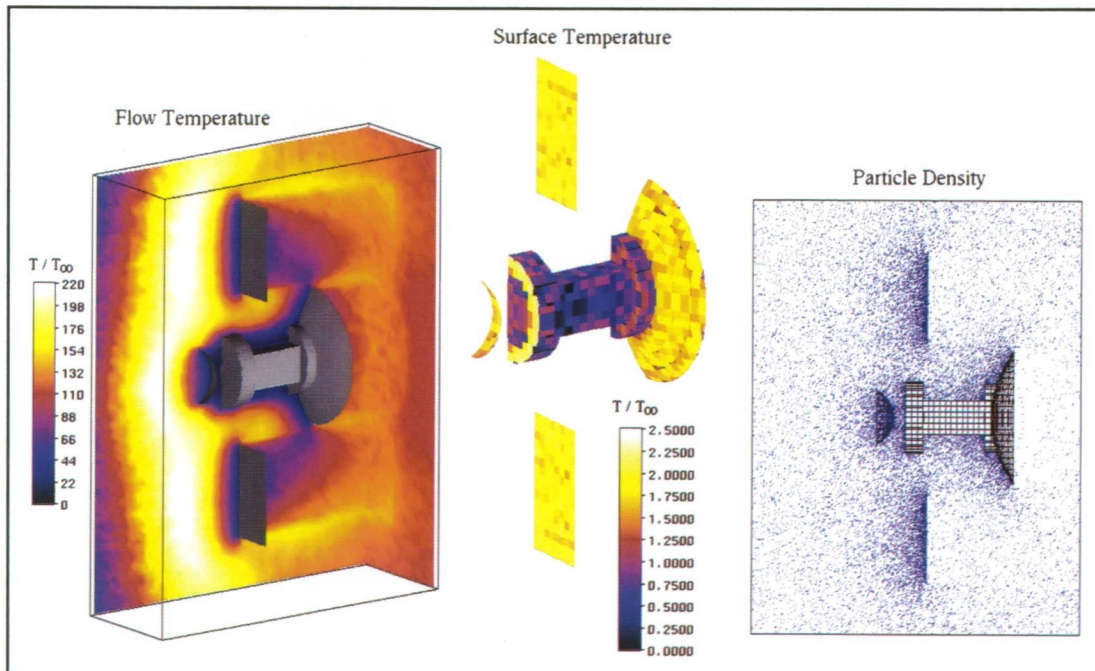

Temperatures and particle distribution during proposed aerobraking of the Magellan spacecraft through the atmosphere of Venus; altitude = 125 km,  $M = 35$ , and  $Kn = 0.103$ .

# Aeroassist Flight Experiment Flow Simulation

William J. Feiereisen, Principal Investigator

Co-Investigators: G. E. Palmer, E. Venkatapathy, D. S. Babikian, D. K. Prabhu, and E. E. Whiting  
NASA Ames Research Center

## Research Objective

To use the numerically computed flow fields in the pre-flight design of the high-resolution spectrometers and total-radiation detectors to be carried on board the Aeroassist Flight Experiment (AFE) vehicle.

## Approach

The three-dimensional aerothermodynamic environment around the AFE vehicle is computed using thermochemical nonequilibrium Navier–Stokes codes. The computed flow fields are then used in conjunction with high-resolution radiation/spectral codes to estimate the radiative flux at the various points on the vehicle surface where the radiometers and spectrometers are located.

## Accomplishment Description

The computed three-dimensional real-gas flow field was used with a high-resolution spectral code to determine the spectrum incident on the vehicle surface. This was done for various lines of sight from the proposed instrument locations on the vehicle. The computed spectra were used with the instrument response functions to determine the sensitivities and data-integration time intervals. A sample spectrum and the computed detector current corresponding to this spectrum are shown in the accompanying figure. This particular calculation was for a line of sight in the forebody stagnation region of the flow. The wake radiation was studied with both the nonequilibrium flow solutions and ideal-gas solutions for the extended wake. The calculations were used to determine the orientations and view angles of the instruments. The sensitivity of the radiation calculations was determined for different entry velocities and altitudes and for various vehicle masses.

## Significance

The computations helped in the preflight design of some of the radiometers to be carried on board the AFE vehicle. The computations highlighted the need for better thermochemical models in the expanding flow regime and in the wake.

## Future Plans

There are no future plans for this project because it has been canceled by NASA.

## Publications

1. Venkatapathy, E.; Palmer, G. E.; and Prabhu, D. K. "AFE Base Flow Calculations." AIAA Paper 91-1372, June 1991.
2. Strawa, A. W.; Park, C.; Davy, W. C.; Craig, R. A.; Babikian, D. S.; Prabhu, D. K.; and Venkatapathy, E. "Radiometric Investigation of the Wake Flow of the Forthcoming Aeroassist Flight Experiment." AIAA Paper 91-1408, June 1991.

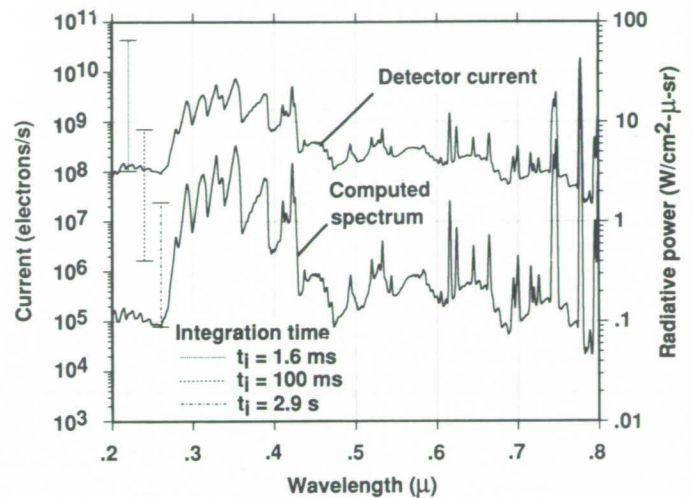

Computed spectrum and detector current in the forebody stagnation region of the Aeroassist Flight Experiment vehicle; detector angle ( $\Omega_d$ ) = 0.0129 sr, area ( $A_d$ ) =  $6.25 \times 10^{-4}$  cm<sup>2</sup>, resolution ( $\Delta\lambda_d$ ) =  $6 \times 10^{-4}$  μ.

# F16xL Supersonic Laminar Low-Control Experiment

Michael C. Fischer, Principal Investigator  
Co-Investigator: Chandra S. Vemuru  
NASA Langley Research Center

## Research Objective

To design and develop passive and suction laminar flow gloves for the F16xL supersonic laminar flow control experiment.

## Approach

Three-dimensional Euler and Navier–Stokes codes are used to predict the flow over the F16xL configuration at supersonic Mach numbers.

## Accomplishment Description

The F16xL SHIP1 and SHIP2 configurations were analyzed by using the EMTAC code at  $M_\infty = 1.7$  and  $\alpha = 3.0$  degrees. The pressure coefficient contours over the planform indicated that the shock location for SHIP2 moved further aft compared to the SHIP1 configuration. However, the strength of the shock is stronger compared to the canopy shock of SHIP1. The canopy shock sweeps across the wing in a location that may limit the fullest extent of laminar flow from being realized, especially at lower Mach numbers. In order to achieve 50–60% laminar flow on the wing, a canopy fairing may be necessary to move the shock further aft. The SHIP2 canopy was faired in the rear part to study the effect of canopy shape. An analysis of the new configuration indicated that the fairing weakened the shock, but the shock location did not change much compared to the SHIP2 geometry. Analysis of the boundary layer and compressible

stability (with and without curvature effects) over the inboard section of the F16xL SHIP1 glove configuration was conducted. The results were compared to the flight-test transition data to determine a critical N-factor value. The boundary layer calculations showed a wide difference in  $Re_{\theta}$  values whereas the N-factor values at 4% chord did not indicate any significant difference. The F16xL SHIP2 configuration was analyzed at  $M_\infty = 1.9$  and  $\alpha = 2.965$  degrees using a C-H grid and the TLNS3D code.

## Significance

Laminar flow control has been identified as one of the key technologies necessary for ensuring the economic viability of High Speed Civil Transport. Laminar flow glove shapes designed in this research program will be flight tested and the wing pressures measured in flight will allow validation of computational design/analysis methods at supersonic speeds.

## Future Plans

The Euler and Navier–Stokes codes will be used to analyze laminar flow glove shapes for the F16xL flight experiment. Grids with different topologies and distributions will be generated using the GRIDGEN program and the theoretical pressure distributions will be compared with the flight data.

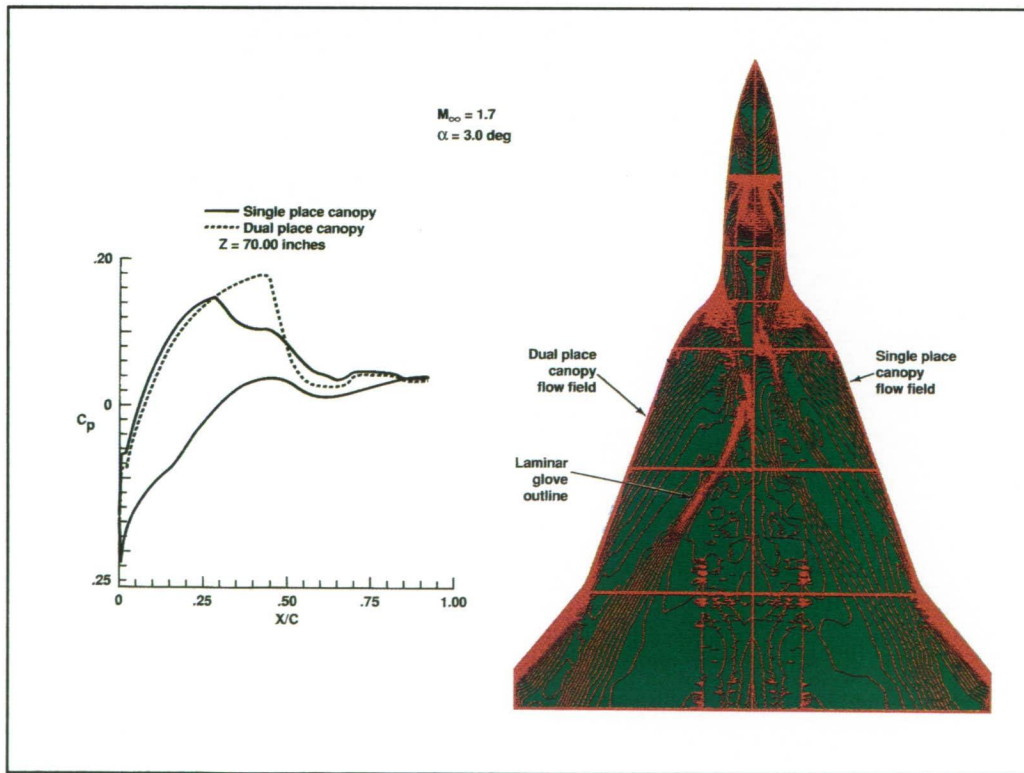

Pressure coefficient contours over an F16xL aircraft;  $M_\infty = 1.7$ ,  $\alpha = 3.0$  degrees.

# Analysis of Slender-Wing Geometries using Unstructured Grids

Neal T. Frink, Principal Investigator

Co-Investigators: Paresh Parikh and Shahyar Pirzadeh

NASA Langley Research Center

## Research Objective

To assess the accuracy and efficiency of a new three-dimensional unstructured-grid software package to compute transonic flow around a high-speed transport configuration.

## Approach

To construct an unstructured tetrahedral grid around a generic High-Speed Civil Transport (HSCT) configuration using the advancing front-grid generation code VGRID3D and compute the inviscid transonic flow field surrounding the configuration at a moderate angle of attack with the unstructured upwind flow solver USM3D. The results will be displayed with the graphic postprocessing code VPLOT3D and quantitative comparisons with experimental data will be provided.

## Accomplishment Description

Two unstructured tetrahedral grids were generated around an HSCT configuration consisting of 184,997 cells and 33,499 nodes for the coarse grid, and 379,561 cells and 67,848 nodes for the fine grid. The total number of cells was kept down by longitudinally stretching the cells near the configuration by a 4:1 ratio. Grid resolution was maintained in the spanwise direction to resolve vortex-induced pressure gradients. Transonic inviscid solutions were obtained for the conditions  $M_\infty = 0.901$  at  $\alpha = 6.47$  degrees and  $M_\infty = 1.194$  at  $\alpha = 3.34$  degrees. The

coarse grid residual was reduced 2.5 orders of magnitude using approximately 1 Cray Y-MP hour and 12 megawords of memory. The fine grid residual was reduced 4.1 orders of magnitude and required approximately 7 Cray Y-MP hours and 24 megawords of memory. The accompanying figure depicts the coarse grid solution. The surface velocity vectors and field Mach contours indicate the presence of leading-edge vortex flow. A second vortex is formed on the outboard panel, while the inboard vortex passes over the aft wing region. Comparisons with experimental data show generally good agreement of the coefficient of pressure inboard of the suction peak and the expected over-prediction of the outboard suction peak by the inviscid solution.

## Significance

The USM3D flow solver provides efficient solutions to the Euler equations within the accuracy of the inviscid assumptions. These solutions were the first results produced by USM3D with leading-edge vortex flow, and with flow in the low-supersonic speed range.

## Future Plans

Work to reduce the turnaround time to produce a satisfactory grid and flow solution is continuing. The range of applications for the software is expanding. Work is under way to develop an unstructured viscous-grid generator and flow solver.



Unstructured-grid solution for a generic High-Speed Civil Transport configuration;  $M_\infty = 0.901$ ,  $\alpha = 6.47$  degrees.

# Turbulent Flow Past a Complete Hypersonic Reentry Configuration

Datta Gaitonde, Principal Investigator  
Co-Investigator: Joseph Shang  
WL/FIMM, Wright Patterson AFB

## Research Objective

To examine the turbulent flow field about complete lifting-body configurations at hypersonic speeds utilizing an accurate and efficient numerical algorithm.

## Approach

The full three-dimensional mean compressible Navier–Stokes equations in mass-averaged variables are solved in a finite volume formulation utilizing Roe’s flux-difference split algorithm for the inviscid fluxes and centered evaluation of viscous fluxes. The implicit numerical algorithm is based on Gauss–Seidel line relaxation. Turbulence closure is presently achieved with the Baldwin–Lomax algebraic eddy-viscosity model.

## Accomplishment Description

The choice of algorithm was based upon a critical examination of MUSCL-based higher-order upwind methods with a range of limiters. Specific emphasis was placed on the prediction of heat transfer rates in viscous flows. The flow past the X24C-10D configuration was then solved with a mesh of roughly 500,000 grid points. The so-called “carbuncle” anomaly in the nose region was eliminated by a combination of different splittings without affecting the overall accuracy. Analysis of the computed turbulent flow field, including a comparison with experimental heat transfer data, is ongoing. The accompanying figure shows surface pressures and Mach contours with an Euler calculation.

## Significance

The ability to accurately and efficiently simulate flow fields past complete reentry configurations is critical in the design process, especially at points in the flight path where the stringent conditions encountered are extremely difficult, if not impossible, to simulate in wind tunnels. This effort should provide a cost-effective alternative in vehicle design.

## Future Plans

The theoretical model will be extended to incorporate high-temperature effects such as thermochemical nonequilibrium and ionization. A two-dimensional version of the code, employing nonequilibrium five-species chemistry and a simple harmonic oscillator model for vibrational energy excitation, has already been developed. A two-equation turbulence closure model will also be examined.

## Publications

1. Gaitonde, D. and Shang, J. “The Performance of Flux-Split Algorithms in High-Speed Viscous Flows.” AIAA Paper 92-0186, Aerospace Sciences Meeting Exhibit, Reno, NV, 1992.
2. Kroll, N.; Aftosmis, M.; and Gaitonde, D. “An Examination of Several High-Resolution Schemes Applied to Complex Problems in High-Speed Flows.” WL-TR-91-3089, Wright-Patterson AFB, 1991.

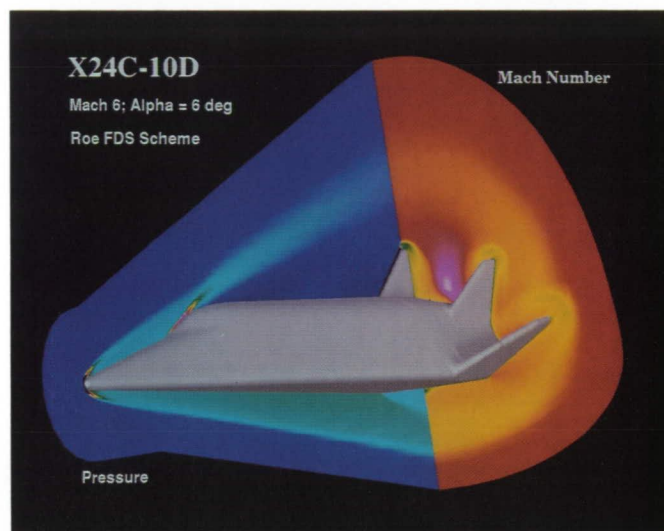

Surface pressures and Mach contours with an Euler calculation;  $M = 6$ ,  $\alpha = 6$  degrees.

# Integrated Hypersonic-Propulsion Flow Paths

Joseph L. Garrett, Principal Investigator  
Co-Investigators: Kevin Van Dyke and Balu Sukar  
Pratt & Whitney/General Electric Aircraft Engines

## Research Objective

To calibrate and use the General Aerodynamic Simulation Program (GASP) to design hypersonic-propulsion flow paths.

## Approach

Calibration of the GASP code was done in two parts. First, the GASP chemistry algorithm was validated against the predictions of the two-dimensional kinetics code. The GASP code was then used to predict the film-coolant distribution for the subscale National Launch System (NLS) calorimeter nozzle. Pressure, temperature, and heat transfer data from the calorimeter-nozzle test will be used to validate the pretest predictions. In addition to the NLS calorimeter nozzle predictions, the GASP code was used to compute the Arnold Engineering Development Center (AEDC) 50 megawatt arc-tunnel nozzle flow for the National Aero-Space Plane (NASP) Mach 11.5 combustor rig.

## Accomplishment Description

An average run required 8 Cray Y-MP hours and 8 megawords of memory for convergence. Pretest predictions for the NLS calorimeter nozzle indicated a potential problem in the film-coolant delivery design that was substantiated and corrected through the use of a model water-flow rig. Pretest predictions of the AEDC 50 megawatt arc-tunnel nozzle flow were used in designing the fuel injection system for the NASP Mach 11.5 combustor-rig test.

## Significance

A potential for burning up the NLS calorimeter injection ring due to a maldistribution of coolant flow was averted. Further, pretest predictions for the entire system will provide the opportunity to validate the GASP code for film injection and heat transfer analyses.

## Future Plans

Upon completion of the NLS and NASP rig tests, the pretest predictions will be compared with test results, and appropriate modifications to the GASP algorithm will be made, if necessary. The GASP code will then be used for design studies in both the NASP and NLS propulsion systems.

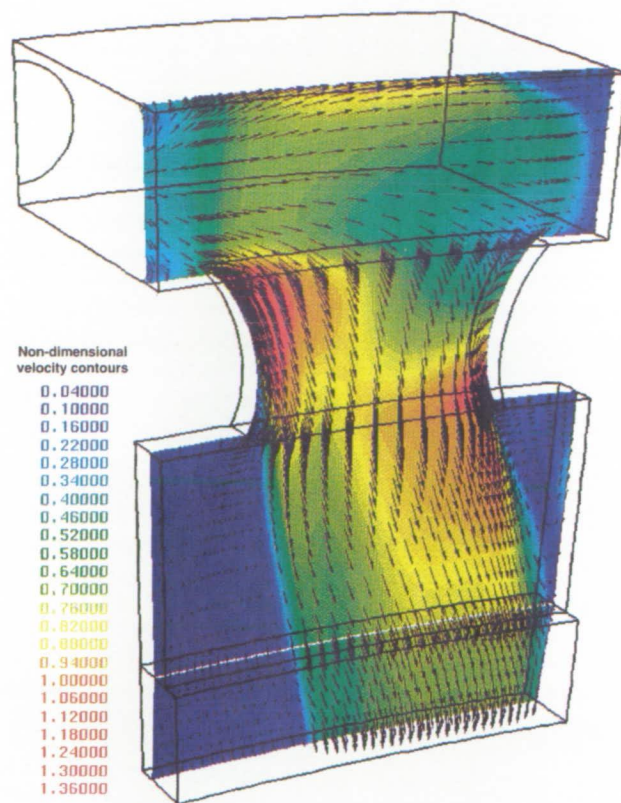

Preliminary National Launch System subscale secondary flow-distribution geometry.

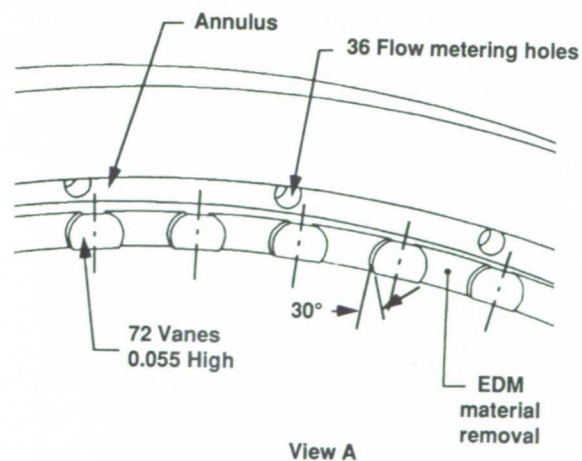

Computational fluid dynamics analysis indicates a maldistribution of film coolant that impacts the design of the secondary flow-distribution system.

# Compressible Turbulent Flows

Thomas B. Gatski, Principal Investigator  
Co-Investigator: Joseph H. Morrison  
NASA Langley Research Center

## Research Objective

To develop a compressible Navier–Stokes algorithm that can use both two-equation and Reynolds stress turbulence closure models to solve complex turbulence flows.

## Approach

A multiblock, cell-centered, finite-volume scheme with good shock-capturing capabilities, accuracy, and general geometric capabilities is developed. A Roe flux-difference splitting technique coupled with a MUSCL scheme is applied to the mean conservation equations for the mass, momentum and energy, and the transport equations for the turbulent Reynolds stresses. Viscous fluxes are discretized using a finite-volume representation of a central-difference operator and the source terms are treated as an integral over the control volume.

## Accomplishment Description

A code capable of handling complex high-speed compressible flows has been developed. Both two-equation and Reynolds stress-transport equations are included in the numerical algorithm. In addition, near-wall models are used in the turbulence closure scheme in order to integrate directly to solid boundaries

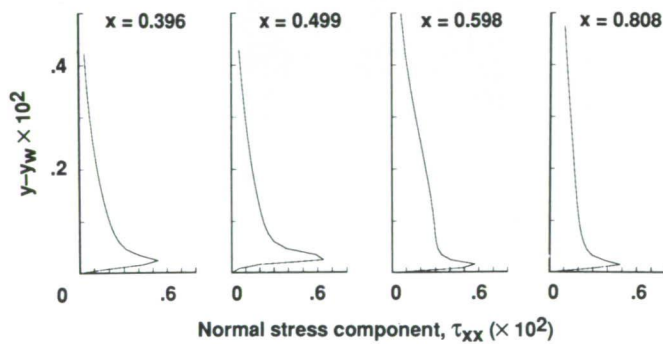

Normal Reynolds stress component profile for a 10 degree compression ramp.

where needed. An average run takes about 4 Cray Y-MP hours and uses 10 megawords of memory. The accompanying figures show the Reynolds stress-component profiles. The flat plate section precedes the ramp which starts at  $x = 0.5$ .

## Significance

Complex turbulent flow fields require more sophisticated turbulence closure models than the simple eddy-viscosity flow fields. Unfortunately, incorporating the Reynolds stress models into Navier–Stokes codes is cumbersome, especially for compressible flows where mass-flux and heat-flux correlations are also present. With the development of the present code, it is possible to validate Reynolds stress-turbulence closure models in complex compressible flows and evaluate their performance relative to simpler turbulence closure models.

## Future Plans

We will apply the Navier–Stokes code to a variety of high-speed compressible flows—both wall-bounded and free-shear. The results will be used to compare the predictive capability of both two-equation and Reynolds stress models with available experimental data.

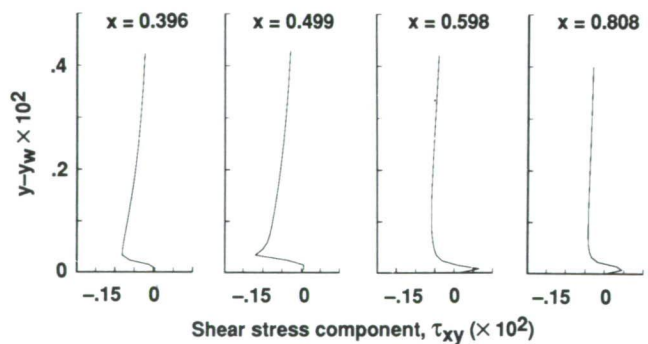

Reynolds shear stress component profile for a 10 degree compression ramp.

# Hypersonic Flows in Chemical and Thermal Nonequilibrium

Peter A. Gnoffo, Principal Investigator  
NASA Langley Research Center

## Research Objective

To simulate hypersonic flow fields in chemical and thermal nonequilibrium. Particular emphasis is placed on the Aeroassist Flight Experiment and the convective and radiative heating distributions on lunar transfer vehicles (LTV) configurations.

## Approach

The three-dimensional Navier–Stokes equations, 11 species-continuity equations, a total-energy equation, and a vibrational-energy equation are solved in a fully coupled, point-implicit, symmetric, total-variation-diminishing algorithm. Uncoupled radiative heating levels can be calculated from converged profile solutions.

## Accomplishment Description

The hypersonic flow over 70-degree spherically capped cones with 50-foot-diameter bases and spherical-segment brakes that are near peak heating conditions for an LTV earth return have been studied. Three-dimensional flows require 5–20 Cray Y-MP hours and less than 40 megawords of memory, depending on the quality of the initial solution and grid density. Significant nonequilibrium effects are confined to a region less than 1 inch thick in a shock layer that is approximately 2 feet thick. As shown in the accompanying figure, grid topologies and adaption algorithms were developed to resolve nonequilibrium phenomena behind the bow shock and eliminate singularity-induced irregularities in heating contours in the stagnation region.

## Significance

Total heating loads on LTV configurations border the upper limits of present thermal protection system materials and are dominated by radiative heating. Accurate predictions of the heating load are required to assess the cost of aerobraking options for LTV applications.

## Future Plans

We will study some of the difficulties with the convergence of nonequilibrium radiative heating levels with equilibrium radiative levels for thick shock layers dominated by equilibrium processes.

## Publications

1. Gnoffo, P. A.; Price, J. M.; and Braun, R. D. "On the Computation of Near-Wake, Aerobrake Flow Fields." *J. Spacecraft and Rockets* 29, no. 2 (Mar./Apr. 1992): 182–189.
2. Gnoffo, P. A. "Point-Implicit Relaxation Strategies for Viscous Hypersonic Flows." In *Computational Methods in Hypersonic Aerodynamics*, ed. T. K. S. Murthy. Southampton, UK: Computational Mechanics Publications, 1991.

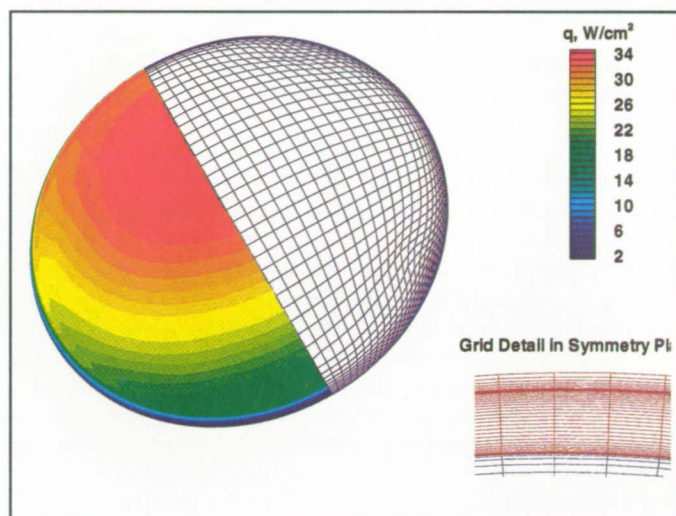

Convective heating contours and a surface grid for a lunar transfer vehicle.

# Unsteady Delta-Wing Flow

Raymond Gordnier, Principal Investigator  
WL/FIMM, Wright Patterson AFB

## Research Objective

To calculate the flow field over a delta wing undergoing an oscillatory rolling motion, thus simulating a wing-rock behavior. This requires the ability to simulate both the steady flow over a delta wing at a fixed angle of attack and roll angle, and the unsteady flow over a delta wing undergoing a rolling motion. Enhancing the maneuverability and controllability of current and future fighter aircraft requires the ability to accurately predict the vortex-dominated flow environment delta wings encounter during rapid maneuvers.

## Approach

The unsteady three-dimensional full Navier–Stokes equations are solved using the Beam–Warming implicit, approximately factored algorithm. A subiteration procedure improves the accuracy and robustness of the algorithm. The governing equations accommodate moving grids, providing the means to incorporate the unsteady motion of the body. The Baldwin–Lomax turbulence model is used for computing turbulent flows.

## Accomplishment Description

Computations were performed for an 80 degree swept delta wing at a 30 degree angle of attack and roll angles of 0 and 45 degrees. Both fully laminar and fully turbulent solutions were considered since the experimental Reynolds number was 400,000. Comparisons with experimental surface pressure measurements showed good agreement for both the laminar and turbulent computations. The laminar flow solution more generally represented the character of the experimental surface pressure. However, the turbulent solution predicted the minimum pressure under the primary vortex more closely. The effects of grid resolution, boundary conditions, and grid topology on the computational results were also investigated. A typical run on the finest grid required approximately 75 Cray-2 hours and 71 megawords of memory.

## Significance

The successful computation of a delta wing undergoing a static roll is an important first step in developing the ability to simulate the unsteady aerodynamics of a dynamic roll maneuver. These computations provide a significant validation of the present numerical technique before undertaking the more costly and complicated wing-rock computations.

## Future Plans

The current numerical procedure will be applied to an 80 degree swept delta wing undergoing a forced wing-rock motion and the unsteady aerodynamics of the maneuver will be investigated.

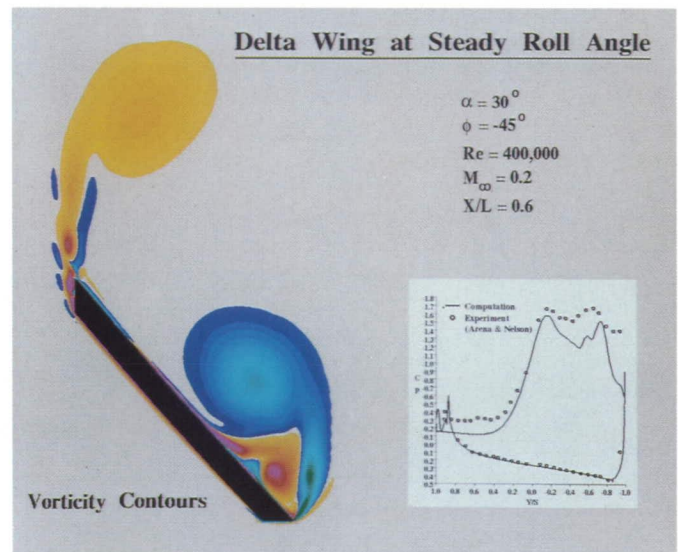

Computations for an 80 degree swept delta wing at 30 degrees angle of attack.

# Numerical Calculation of a Three-Dimensional Separated Flow

Isaac Greber, Principal Investigator  
Case Western Reserve University

## Research Objective

To elucidate the vortex structures that develop in the three-dimensional flow pattern induced by a nominally two-dimensional shock-wave boundary-layer interaction in a wind tunnel or inlet configuration. Special effort was taken to investigate the role of boundary-layer thickness and nonuniformities of the approach boundary layer on the three-dimensionality of the interaction pattern, especially on the vortex-like pattern that develops.

## Approach

Three-dimensional Navier–Stokes codes were used to compute the flow field in a rectangular geometry. The shock wave was modeled as an inflow condition over a section of the computational boundary. The effects of turbulence models were investigated along with the ability to describe the corner flows that occur. Graphical depictions of the vortex structures were developed.

## Accomplishment Description

A three-dimensional Navier–Stokes code using a LUSSOR scheme, the NASA RPLUS code, was modified for this application. Computations of two-dimensional shock-wave impingement in laminar and turbulent flow were made and showed reasonable agreement with published computational results. The results of duct flows show similar vortex structure in both laminar and turbulent flows and the structure agrees with experimental observation. The calculated results demonstrate that the confinement of the flow is the essential cause of the three-dimensionality of the separation. The thickness of the

approach boundary-layer relative to the duct width is a critical parameter in determining the three-dimensional shape of the separation structure. Each three-dimensional computation required about 8 Cray Y-MP hours and 5.5 megawords of memory.

## Significance

The three-dimensional interaction with vortical structures is fundamental not only to shock-induced separation in a confined geometry, but to any separated flow field that has a spanwise length scale. The results are directly applicable to inlet design for jet engines operating in supersonic flight.

## Future Plans

In order to have an accurate quantitative comparison with experimental results for duct flow, further work on developing a turbulence model that reflects the physical characteristics of the flow field is required. A finer grid is needed and a numerical scheme with less artificial damping will be extremely useful.

## Publications

1. Yang, W. and Greber, Isaac. "Numerical Simulation of a Three-Dimensional Shock Wave/Boundary Layer Interaction." Presented at the AIAA Mini-Symposium on Aerospace Technology in Northern Ohio, Cleveland, OH, Sept. 1990.
2. Yang, W. "Numerical Simulation of a Shock Wave/Turbulent Boundary Layer Interaction in a Duct." Ph.D. Dissertation, Case Western Reserve University, Cleveland, OH, May 1992.

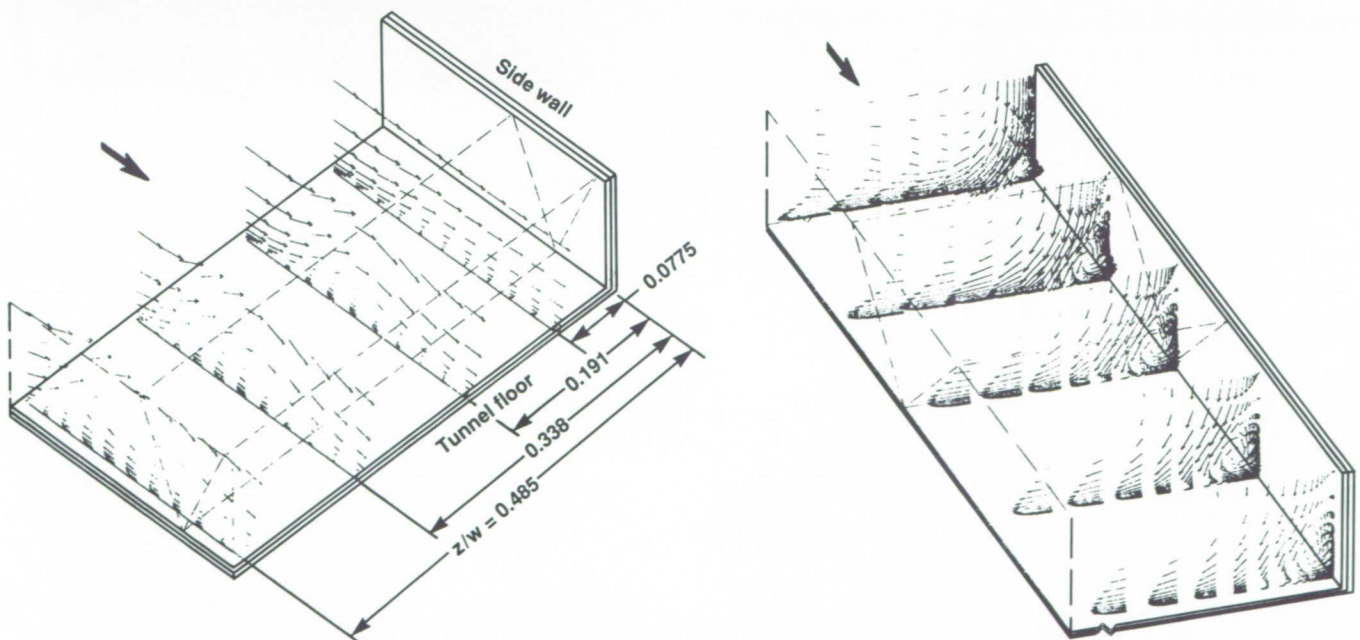

Shock/turbulent duct flow interaction;  $M = 2.9$ ,  $Re_w = 1.3^6 \times 10^6$ ,  $\alpha = 12.99$  degrees,  $\delta/w = 0.0712$ . (a) Streamwise velocity field of the separation structure near the center plane. (b) Spanwise velocity field of the corner vortex structure.

# Spatially Evolving Reactive Jets

Fernando F. Grinstein, Principal Investigator  
Naval Research Laboratory

## Research Objective

To understand the dynamics and topology of the large-scale coherent structures controlling the development of reactive free jets.

## Approach

To develop a numerical solution of the three-dimensional time-dependent compressible flow equations on structured grids. The model uses a fourth order flux-corrected transport (FCT) algorithm and appropriate inflow and outflow boundary conditions for convective transport, one-step, irreversible, finite-rate (Arrhenius) chemistry, and realistic (temperature- and species-dependent) diffusive transport. No subgrid modeling other than that provided by the FCT high-frequency filter is included in the numerical model.

## Accomplishment Description

The investigation of the effects of exothermicity, diffusive transport, and three-dimensional spanwise excitation on reactive mixing layers was continued. We performed simulations of spatially evolving round and square free-jets. The accompanying figure shows a typical instantaneous visualization of the outstanding topological features of a developed, nonreactive square jet. Shown are the rolling-up of the square vortex sheet near the inflow into vortex-ring structures; deformation and axis switching of the rings due to self-induced velocity in the corners; longitudinal (streamwise) structures caused by the stretching of the streamwise vorticity introduced by the corners; and a disorganized region of the flow depicting the later stage of vortex merging. Streamwise vorticity of both signs introduced as a consequence of the self-induced distortion of the loops is crucial in determining the larger entrainment and mixing properties of the square jet relative to its circular counterpart. This simulation used  $120 \times 80 \times 80$  computational cells, and about 29 Cray Y-MP hours.

## Significance

The simulations provide insight into the physics of large-scale coherent structures in free-shear flows and the mechanisms affecting the growth of mixing layers and the transition to turbulence. This effort advanced state-of-the-art transitional shear-flow simulations.

## Future Plans

The studies will be extended to rectangular jets and the investigation of flame-extinction phenomena in jets.

## Publications

1. Grinstein, F. F. and Kailasanath, K. "Compressibility, Exothermicity, and Three-Dimensionality in Spatially-Evolving Reactive Shear Flows." 13th ICDERS, Nagoya, Japan, July 1991.
2. Grinstein, F. F. "Coherent-Structure Dynamics in Spatially-Developing Square Jets." *Bull. Amer. Phys. Soc.* 36 (1991): 2699.

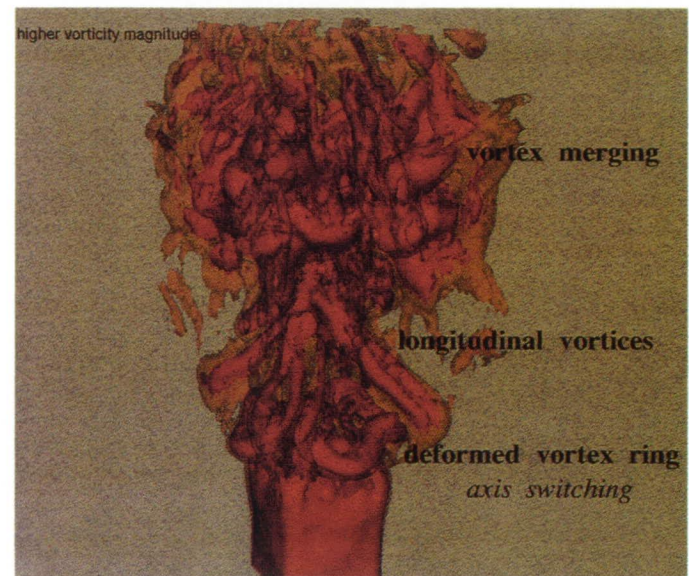

Visualization of a square jet in terms of vorticity magnitude. The jet is subsonic ( $M = 0.6$ ) and is axially forced ( $fD/U = 0.3$ ).

# Three-Dimensional Atmospheric Simulation Model

W. L. Grose, Principal Investigator

Co-Investigators: W. T. Blackshear, R. S. Eckman, and R. E. Turner  
NASA Langley Research Center

## Research Objective

To conduct a three-dimensional simulation of the evolving atmospheric circulation and trace constituent distributions over a multiyear cycle in order to better understand stratospheric dynamics, transport, and photochemistry and to apply this knowledge to support the Upper Atmospheric Research Satellite (UARS) program.

## Approach

A three-dimensional, spectral, primitive-equation, atmospheric model incorporating chemistry has been developed. It consists of two components: a model that calculates the winds and temperatures to describe the global atmospheric dynamics, and a separate transport/chemistry model (driven by the simulated dynamics) to describe transport of photochemically active trace constituents.

## Accomplishment Description

A model simulation provided a baseline for assessing the temporal and spatial variation of stratospheric trace species. Initial efforts are in progress to compare model results of stratospheric chlorine monoxide (ClO) with measurements made by an instrument on board the recently launched UARS. Calculations of enhanced levels of ClO resulting from heterogeneous chemical processes during the southern polar winter and spring are in satisfactory agreement with observation. Studies of the budget of the odd nitrogen family in the stratosphere are continuing. Modifications to the transport/chemistry module are made on a continuing basis in an effort to enhance model performance. Typically, the model requires 600 Cray Y-MP seconds per model day and uses 4 megawords of memory.

## Significance

This model provides increased understanding of stratospheric dynamics, transport, and photochemistry, and supports the UARS and Earth Observing System programs.

## Future Plans

Improvements in the horizontal and vertical resolution of the model are in the planning stage. The increased resolution will better describe small-scale features that are presently not fully resolved in the model. An additional multiyear simulation is planned with an enhanced parameterization of heterogeneous chemistry. One focus of the simulation will be the appraisal of the importance of background aerosols on the chemistry of the mid-latitude and tropical stratosphere.

## Publications

1. Grose, W. L.; Waters, J.; Eckman, R. S.; Froideveaux, L.; and Elson, L. S. "The Distribution of Ozone and Chlorine Monoxide in the Stratosphere: Comparisons of Microwave Limb Sounder Data with a Three-Dimensional Chemistry/Transport Model Simulation." Presented at the International Symposium on Middle Atmosphere Science, Kyoto, Japan, March 1992.
2. Eckman, R. S.; Turner, R. E.; Blackshear, W. T.; Fairlie, T. D. A.; and Grose, W. T. "Some Aspects of the Interaction Between Chemical and Dynamical Processes Relating to the Antarctic Ozone Hole." To be published in *Advances in Space Research*, 1992.

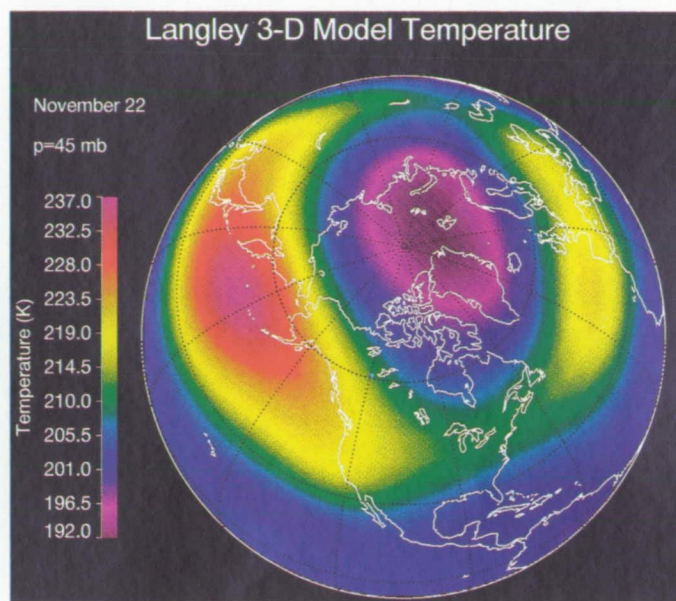

NASA Langley three-dimensional model calculates temperatures to describe global atmospheric dynamics.

# Rotor–Stator Interaction in Turbomachines

Karen L. Gundy-Burlet, Principal Investigator  
Co-Investigator: Akil Rangwalla  
NASA Ames Research Center

## Research Objective

To investigate unsteady rotor–stator interaction in single-stage and multistage turbomachines.

## Approach

Unsteady three-dimensional Navier–Stokes zonal codes have been developed to investigate unsteady flows in single-stage (ROTOR-4 code) and multistage (STAGE-3 code) turbomachines.

## Accomplishment Description

The nonlinear equations are advanced in time using a third-order accurate, implicit, upwind-biased algorithm. Body conforming “O” grids are used to accurately resolve the viscous effects associated with each airfoil. These grids are overlaid on sheared cartesian grids which resolve the flow field between blades. The cartesian grids are allowed to slip past each other, simulating the relative motion between rotors and stators. The STAGE-3 code has been applied to a 2.5-stage compressor configuration for which a large body of experimental data exists. Preliminary time-averaged surface pressures are in good agreement with experimental data. The computation requires 10 megawords of main memory and approximately 600 Cray Y-MP hours. The ROTOR-4

code has been used to perform a fine-grid three-dimensional calculation of a turbine stage. The numerical results have indicated some remarkable secondary flow features that had not been seen in previous rotor–stator simulations. These results are in the process of being validated and will improve our understanding of the physical nature of flows through turbomachines. This computation requires 35 megawords of memory and approximately 400 Cray Y-MP hours.

## Significance

Unsteady turbomachinery flow fields are extremely complex, especially in the latter stages of multistage turbomachines. Wake–wake and wake–airfoil interactions cause complex time-varying forces on the downstream airfoils. It is important to understand these interactions in order to design turbomachines that are light, compact, reliable, and efficient.

## Future Plans

On completion of the turbine-loss calculation and the 2.5 stage compressor computation, the results will be compared with experimental data from test rigs. Future efforts will include a fine-grid 2.5-stage compressor computation.

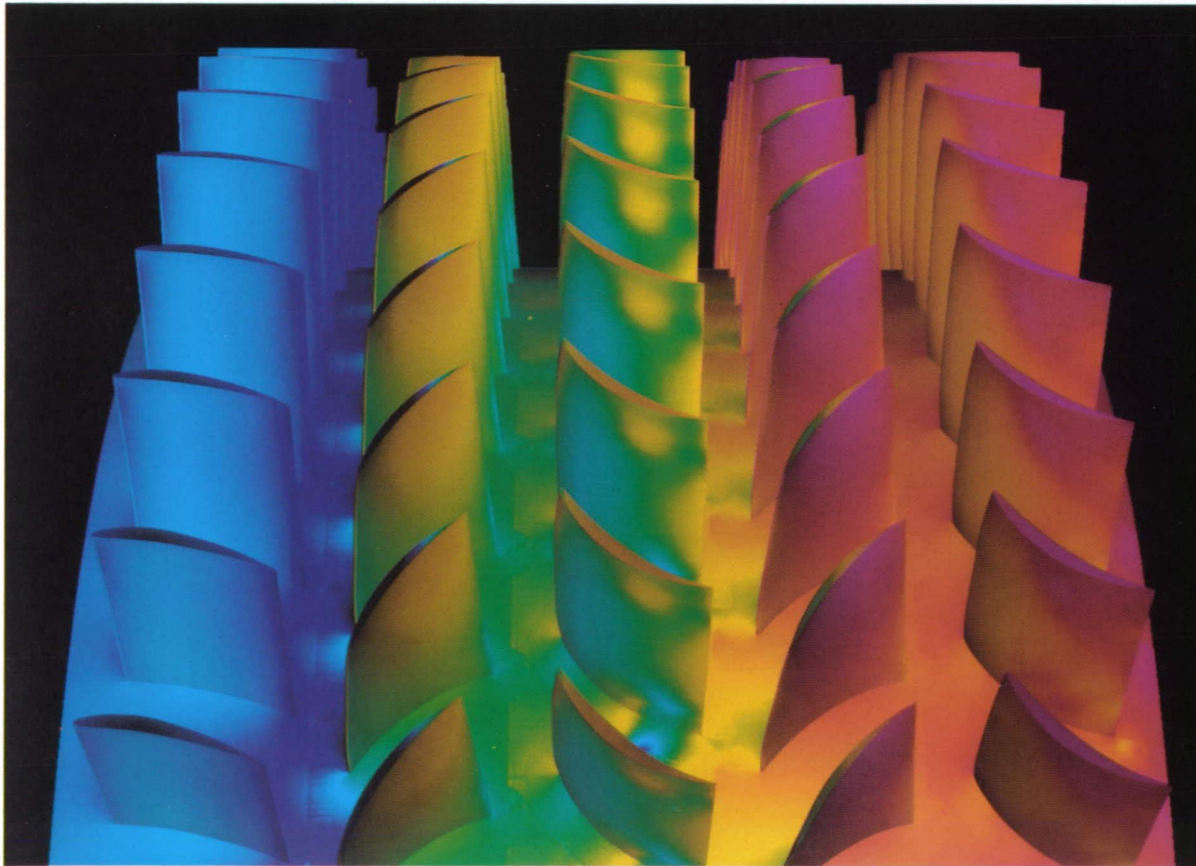

*Preliminary instantaneous surface-pressure contours in a 2.5-stage compressor.*

# Fluid and Structure Integration for Aerospace Applications

Guru P. Guruswamy, Principal Investigator  
Co-Investigator: Shigeru Obayashi  
NASA Ames Research Center

## Research Objective

To develop the numerical capability to couple Euler and Navier–Stokes solutions with finite-element structural equations to conduct aeroelastic analysis of complete aircraft. This capability is required for aerospace vehicles of national importance.

## Approach

The three-dimensional Euler/Navier–Stokes equations directly coupled with the finite-element structural equations of motion are solved by time-accurate numerical schemes.

## Accomplishment Description

ENSAERO, a code based on the Euler/Navier–Stokes equations, is used to simulate unsteady flows over flexible wing–body configurations. The code uses implicit finite-difference methods for aerodynamic calculations based on both central and upwind schemes. A capability of directly coupling the aerodynamic solutions from the Euler or Navier–Stokes equations with the structural equations for computing aeroelastic responses is incorporated in the code for wing–body configurations. This is the first time that such a computational capability has been developed in the area of computational fluid dynamics using the Navier–Stokes equations for wing–body configurations. Using

ENSAERO, vortical and transonic flows are computed over rigid and flexible wing–body configurations in unsteady motions, including vortex breakdown. The effect of body flexibility on the aeroelastic responses is demonstrated. A typical aeroelastic computation on a wing–body model undergoing a ramp motion from 0 to 15 degrees requires about 25 Cray Y-MP hours with a 500,000 point grid and needs about 32 megawords of memory.

## Significance

This project demonstrates the capability of computational methods to simulate aeroelasticity associated with complex vortical and transonic flows for improving the performance of an aircraft. It will also serve as a major stepping stone toward developing a multidisciplinary version of ENSAERO for full-aircraft analysis.

## Future Plans

Research will be continued to compute unsteady flows over flexible wing–body configurations with vertical tails and control surfaces. ENSAERO will be extended as a multidisciplinary code to study fluid–structural interactions of complete aerospace vehicles.

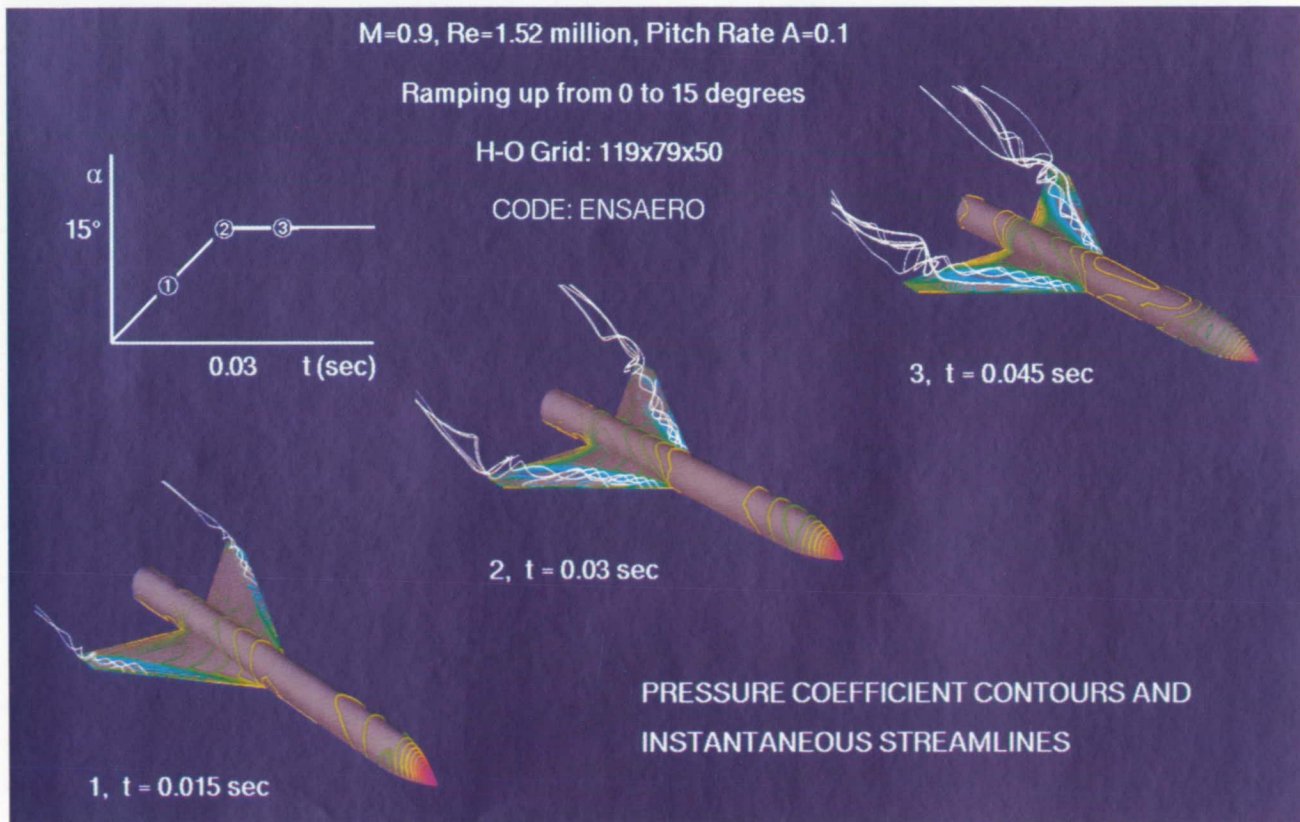

Unsteady Navier–Stokes computations on a wing–body configuration in ramp motion.

# Airfoil Lift and Thrust Generation in Hover Mode

Karl E. Gustafson, Principal Investigator  
Co-Investigator: Robert R. Leben  
University of Colorado, Boulder

## Research Objective

To complete a full-parameter study of the relevant input variables for effect on computed coefficients of lift. The results will be compared to experimental coefficient-of-thrust measurements and will be used to tune airfoils for maximum lift and thrust.

## Approach

We use a two-dimensional stream-function vorticity scheme with a grid-generation scheme that avoids truncation approximation in the far field. Stream function computations are performed by a multigrid solver and an alternating direction-implicit scheme that advances the vorticity values in time. A multigrid generation scheme provides the boundary-fitted coordinates. Coefficients of lift are calculated by a surface pressure integration.

## Accomplishment Description

Higher Reynolds number (1,700) runs were performed for a full range of plunge and pitch amplitudes. A typical computation on a  $65 \times 65$  grid required 5 megawords of memory and 1 CPU hour for four periods in a typical hovering mode. The data were

used to calculate coefficients of lift. Excellent correlation was found between the surface calculated coefficient of lift and the laboratory downstream measurements of coefficient of thrust. The accompanying figure shows a typical vorticity plot from which the coefficients were calculated. In all modes, the qualitative relationships between different pitch and plunge parameters were preserved. In modes similar to water treading, the quantitative similarities were remarkable. Coefficients of lift in excess of 5 were easily obtained.

## Significance

The use of dynamic stall vortices for production of very high thrust are well demonstrated by hovering-mode flight. This hovering-mode model, based on observations of the flight of small birds, dragonflies, and other small insects, should be useful in understanding the characteristics of unsteady aerodynamics.

## Future Plans

An algorithmic upgrade is under way to allow larger Reynolds numbers to be tested. Other unsteady hovering modes are under investigation.

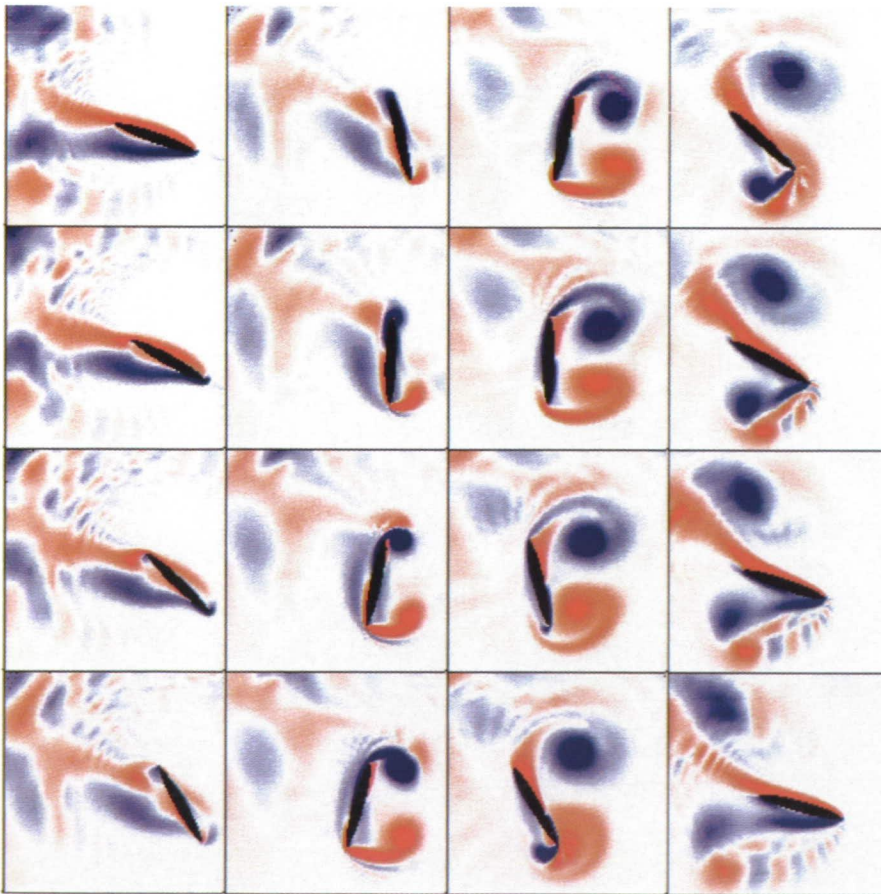

*Vorticity plot for an oblique-jet hovering mode. Coefficients of lift of approximately 3 are obtained.*

# Unsteady Counterrotation of Ducted Propfans

Edward J. Hall, Principal Investigator  
General Motors Corporation, Allison Gas Turbine Division

## Research Objective

To investigate the aerodynamics of ultra-high-bypass ducted-fan aircraft propulsion systems. Large-scale aerodynamic predictions provide a detailed description of the flow through the fan and the external flow about the fan cowl and engine nacelle.

## Approach

A three-dimensional time-marching finite-volume Euler/Navier–Stokes analysis is used to predict steady and time-dependent flows about ducted- and unducted-fan aircraft propulsion systems employing multiple blade rows. The analysis is based on a multiple-blocked grid solution utilizing a cylindrical coordinate system. The multiple-blocked grid discretization is applied to simulate the flow about the internal fan components (the rotor and stator) and the fan cowl. Individual grid blocks are numerically coupled through the mutual specification of boundary conditions along the interfaces joining adjacent blocks. Blade passages are discretized by a series of H-type grids. Grid blocks for neighboring blade rows share a common surface of revolution boundary, across which either circumferentially averaged (steady) or spatially reconstructed (unsteady) flow data are transferred. Ducted fans utilize an additional C-type mesh about the leading edge of the cowl, which improves the resolution of the flow predictions in this critical region. The scheme employs a number of steady-state convergence acceleration techniques, such as local time-stepping, residual smoothing, and multigrids. The residual smoothing and artificial dissipation terms are also carefully constructed to permit their application for time-accurate flow predictions.

## Accomplishment Description

The calculations demonstrate the aerodynamic interactions occurring between adjacent blade rows, and illustrate the need for design analysis tools capable of predicting such phenomena. A typical time-dependent calculation required 30–80 hours on the Cray Y-MP and Cray-2 and 20–80 megawords of memory, depending on the grid density and number of blades in each row.

## Significance

There is a substantial improvement in propulsive efficiency over current high-bypass ratio engines. However, ultra-high-bypass ratio engines impose stringent demands on the aerodynamic and structural integration of large, variable-pitch airfoils in minimum length, low-drag cowls. This code will contribute to improved efficiency and reliability for ultra-high-bypass fans, ultimately leading to the incorporation of this technology in the civil and military transport industry.

## Future Plans

The multiple-blocked Euler/Navier–Stokes scheme will be used to study endwall casing treatments that enhance fan stall margin and reduce noise. The code will be used to predict the time-dependent flow field in the NASA Stage 37 test geometry. Parallel computing concepts will be explored to reduce the computation time for these calculations.

## Publication

Hall, E. J. and Delaney, R. "Investigation of Advanced Counterrotation Blade Configuration Concepts for High-Speed Turboprop Systems: Task V—Unsteady Counterrotation Ducted Propfan Analysis." NASA CR-187126, Jan. 1993.

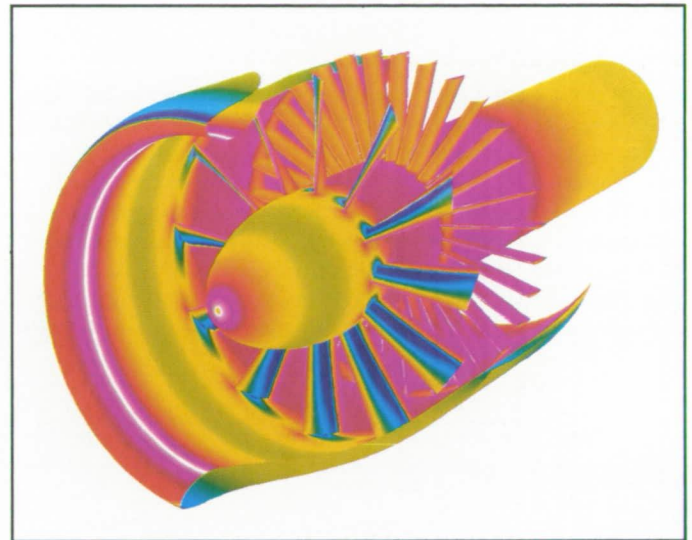

*Predicted static-pressure contours for the NASA 1.15 pressure-ratio fan.*

# Satellite Data Assimilation and Ocean General Circulation Models

David Halpern, Principal Investigator

Co-Investigators: Y. Chao and C. Roberto Mechoso

Jet Propulsion Laboratory/University of California, Los Angeles

## Research Objective

To determine a method to extrapolate satellite measurements of sea-surface height throughout the ocean interior by combining the geodetic satellite (GEOSAT) altimeter data with the National Oceanic and Atmospheric Administration Geophysical Fluid Dynamics Laboratory (GFDL) ocean general circulation model (OGCM) of the tropical Pacific Ocean.

## Approach

The first phase was completed last year when the OGCM was transferred to NASA Ames. The second phase consists of a comparison of monthly mean sea-surface heights measured at island stations, computed from GEOSAT, and simulated with the OGCM and the Florida State University ship-based surface-wind field.

## Accomplishment Description

The accompanying figure shows that the quality of the data sets at the selected sites was similar. The average standard deviations of the sea-level measurements, GEOSAT data, and OGCM simulations were 9.8, 8.9, and 7.1 cm, respectively. Had daily wind stresses been used instead of monthly mean values, the variability of the OGCM simulations would have been higher. At sites located far from the equator, such as Guam (a) and Pago Pago (b), which are located at about 14°N north and south of the equator, the annual cycle is identified. Sea surface heights

at Guam and Pago Pago are lower in northern hemisphere winter and spring. The absence of an out-of-phase relationship between Guam and Pago Pago requires additional study. In 1987, when an El Niño occurred, the sea surface was lower near the equator in the western Pacific (c) and higher in the eastern equatorial Pacific (d), which was a priori expected. The pattern reversed in 1988 during the intense La Niña. The average correlation coefficients between GEOSAT and OGCM data and the sea-level measurements were 0.64 and 0.71, respectively. At some sites the correlation was poor. The low correlation at Santa Cruz (d) might be caused by inadequate accounting of the amount of atmospheric water vapor, which lengthens the radar-altimeter signal travel time.

## Significance

The differences between OGCM simulations and sea-level data were comparable to the differences between GEOSAT and sea-level measurements. The amount of improvement in the description of oceanographic subsurface parameters when GEOSAT data are assimilated into the OGCM remains to be determined.

## Future Plans

We will determine a method to use the difference field between OGCM simulation and GEOSAT data in a reinitialization of the OGCM.

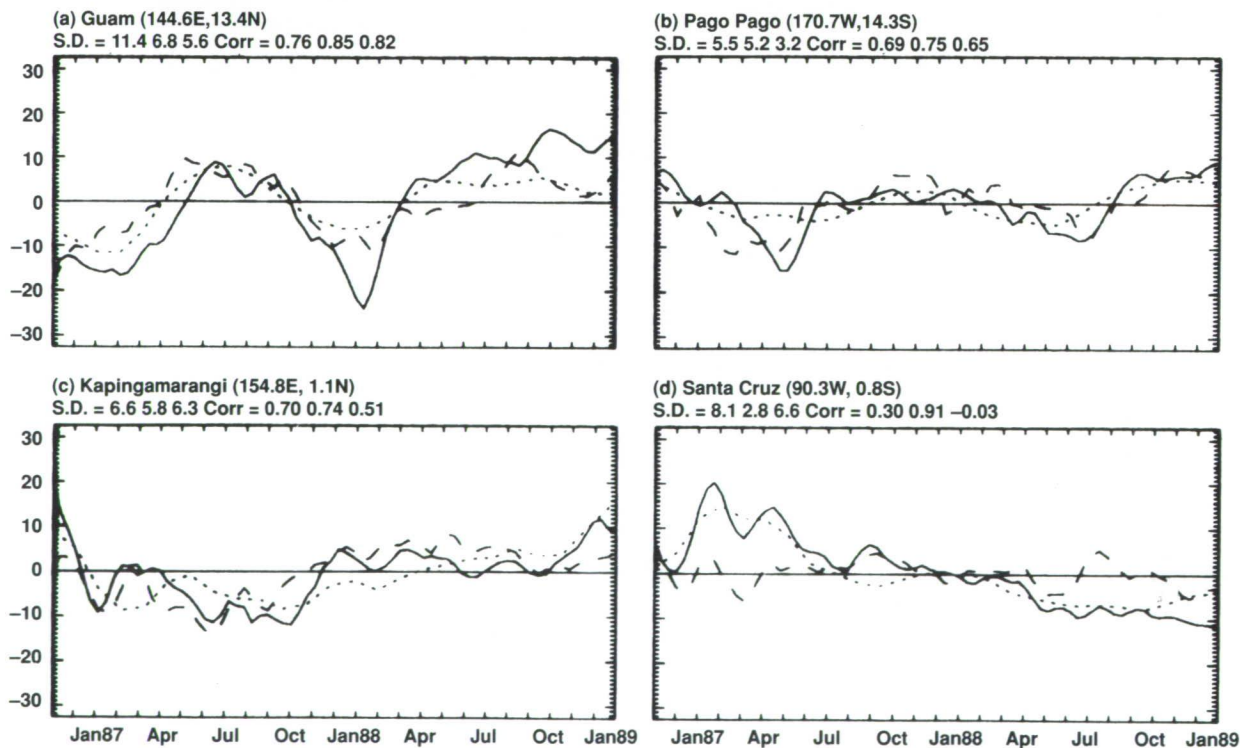

# Atmospheric General Circulation Model Sensitivity to Sea Surface Temperature Fields

David Halpern, Principal Investigator

Co-Investigators: C. Roberto Mechoso and Robert Haskins

Jet Propulsion Laboratory/University of California, Los Angeles

## Research Objective

To determine the sensitivity of the University of California, Los Angeles (UCLA) atmospheric general circulation model (AGCM) to global monthly mean sea-surface temperature (SST) distributions compiled from sparsely and unevenly sampled observations recorded by ships (COADS) and from satellite measurements with very little aliasing (HIRS2/MSU).

## Approach

UCLA AGCM simulations with HIRS2/MSU and COADS SST data sets prescribed as boundary conditions will be compared with a control run involving only SST climatology. Ensembles of five 30-day mean fields are obtained from integrations performed in the perpetual-January mode. Results are presented as anomalies (departures of each ensemble-mean from control simulation).

## Accomplishment Description

Large differences are found between the anomalies obtained using COADS and HIRS2/MSU SSTs, even in the northern hemisphere where the data are most similar. Patterns of geopotential height anomalies obtained using COADS SSTs resembles the first empirical orthogonal function (EOF 1) in the control simulation, while those obtained with HIRS2/MSU SSTs resembles second empirical orthogonal functions. To examine the reasons for the results, three additional simulations are made with SST anomalies confined to regions where COADS SSTs are substantially warmer than HIRS2/MSU SSTs. As shown in the accompanying figure, regions correspond to warm pools in the northwest and northeast Pacific and the northwest Atlantic. Warm pools tend to produce positive geopotential height anomalies in the northeastern oceans through the effects of transient-eddy anomalies, thus shifting northward the corresponding storm tracks. Both Pacific warm pools produce large-scale circulation anomalies that resemble those obtained using COADS SSTs; the Atlantic warm pool does not. The EOF 1 pattern of the control simulation has a closer association with positive geopotential height anomalies over the northwest Pacific. In the northern hemisphere and the tropics, the 500 mb geopotential height anomalies obtained using COADS SST are more similar to the observed than those obtained using HIRS2/MSU SST. In the southern hemisphere, HIRS2/MSU SST generated heights are positively correlated.

## Significance

The impact on atmospheric circulation of uncertainties in current SST distributions for the world ocean can be as important as the SST anomalies. Caution is warranted when linking anomalous circulation and SST patterns in long-range prediction.

## Future Plans

We will determine whether the conclusions from this study are similar for a perpetual-July mode.

## Publication

Ose, T.; Mechoso, C. R.; and Halpern, D. "A Comparison Between General Circulation Model Simulations using Two Sea-Surface Temperature Data Sets for January 1979." *Journal of Climate*, in revision.

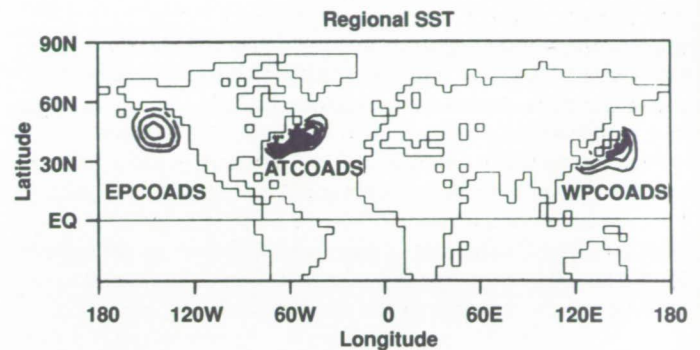

The regional sea-surface anomalies used in the Atlantic (ATCOADS), northeast Pacific (EPCOADS), and northwest Pacific (WPCOADS). Contour interval is 0.5° C.

# Transonic Analysis on Unstructured Grids

David W. Halt, Principal Investigator  
McDonnell Aircraft Company/McDonnell Douglas Research Laboratories

## Research Objective

To demonstrate the accuracy and efficiency of a characteristic-based unstructured-grid Euler solver for complex flow fields by comparison of numerical solutions against test data.

## Approach

Roe's scheme is implemented on an unstructured grid with second-order accuracy using Frink's methodology. Grids are generated with Lohner's advancing-front grid generator using a background mesh to control desired grid clustering. A three-stage explicit Runge-Kutta scheme with implicit residual smoothing is used to advance the solution in time.

## Accomplishment Description

An unstructured mesh with a quarter million tetrahedra is used for the ONERA M6 wing transonic case at Mach 0.84 and 3.06 degrees angle of attack. A lambda shock results on the upper surface and pressures compare well with experimental Pitot measurements. A more complex F-15 wind tunnel model configuration is chosen for comparison including wing, fuselage, tails, and inlet detail. An unstructured mesh with a quarter million tetrahedra is used for this configuration. In the accompanying figure, numerical pressures compare relatively well with Pitot measurements at Mach 0.9 and 5 degrees angle of attack. About 4 Cray-2 hours and 17 megawords of memory were used for the ONERA M6 wing case. About 10 Cray-2 hours and 17 megawords of memory were used for the F-15 case.

## Significance

This method is efficient for analyzing complex configurations with relatively accurate comparisons made from existing test data.

## Future Plans

Store calculations with an F-18 wind tunnel model are planned and will be compared to existing force and moment wind tunnel data. Grid adaptation using a Delaunay grid-generation method will be investigated. Future plans include compact high-order characteristic-based schemes and Navier-Stokes implementation.

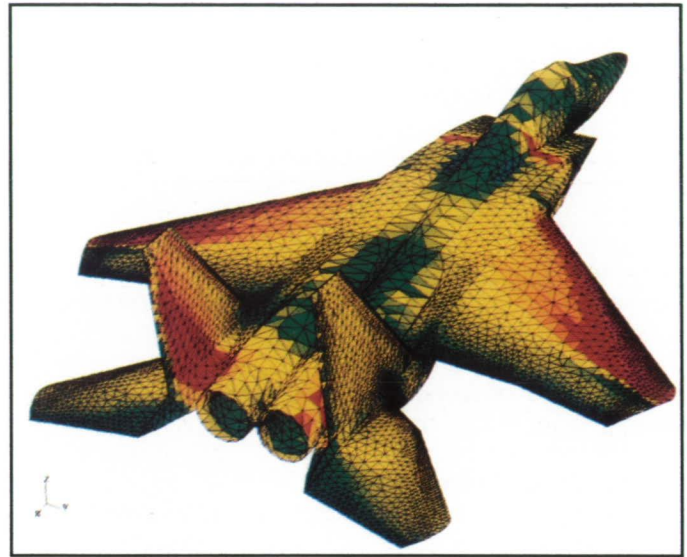

F-15 surface color Mach contours; Mach = 0.9 and angle of attack = 5 degrees.

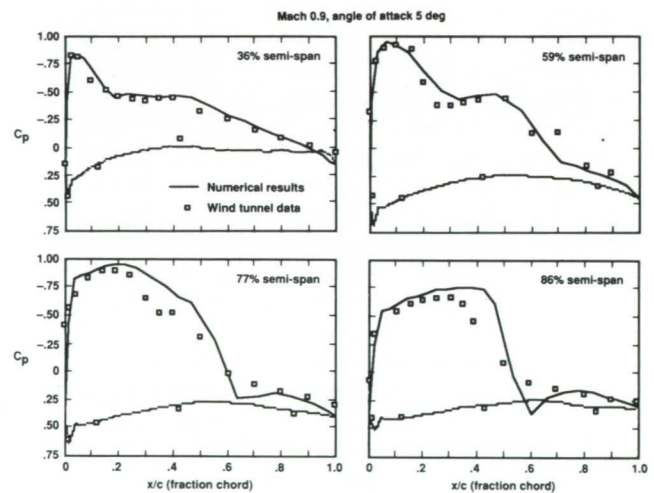

Wing pressure-coefficient comparisons with test data.

# Radiative Structure in Aerobrake Shock Layers

H. Harris Hamilton, Principal Investigator  
Co-Investigator: Robert B. Greendyke  
NASA Langley Research Center/ViGYAN, Inc.

## Research Objective

To investigate the influence of kinetic modeling assumptions from several flow-field solution methods on the noncoupled radiative structure of aerobrake shock layers. Analysis of the excited-state population distribution will provide insight into the effect of macroscopic-flow boundary conditions upon radiative heat-transfer studies.

## Approach

Flow-field solutions calculated with LAURA code were obtained from a related study of electron-number densities. The LAURA code used was an axisymmetric Navier–Stokes solution method coupling 11 species-continuity equations and both a total-energy equation and a vibrational-electronic energy equation. The results were used in the NEQAIR line-by-line nonequilibrium radiation code and the flow-field solution stagnation streamline. The NEQAIR code calculates the emission and absorption coefficients for the nitrogen and oxygen species used to calculate the absorbing incident radiative flux in the shock layer. The individual radiative processes were separated from the total flux to provide process profiles from the shock to the wall.

## Accomplishment Description

The NEQAIR code was applied to flow fields having two ionization-potential energy assumptions, three commonly used chemical rate models, and three different values for the limiting cross section for vibrational excitation. The radiative structure was analyzed for the LAURA-code baseline kinetic model at several points along a typical Aeroassist Flight Experiment trajectory. Two radiative processes were found to be significant in this study—radiation resulting from atomic nitrogen bound–bound transitions and ionized diatomic nitrogen’s first negative band. Considering the high computational cost of the NEQAIR code, substantial computational savings could be realized by using only these two processes. Flow-field assumptions exerted a considerable effect on the total radiative flux at the wall. Occasionally, the modification of the chemical rate model used had a factor of 3 difference on the calculated radiative heat transfer to the wall (shown in the accompanying figure). The effect of temperature profiles, and the assumption that electron temperature could be assumed equal to vibrational temperature, was highly significant to the overall radiative structure.

## Significance

Valuable insight into the effects of flow-field solution methods upon the microscopic processes involved in hypersonic nonequilibrium radiation was provided. The results directed us to areas of further flow-field solution method adaptations for the more accurate calculation of radiative heat transfer.

## Future Plans

The accuracy of wall-boundary conditions will be examined related to boundary-layer radiative absorption and total flux to the wall. Similar methodology will be applied to the FIRE II vehicle data.

## Publications

1. Greendyke, R. B. “A Parametric Analysis of Radiative Structure in Aerobrake Shock Layers.” AIAA Paper 92-2970, 23rd AIAA Plasmadynamics and Lasers Conference, Nashville, TN, July 1992.
2. Greendyke, R. B.; Gnoffo, P. A.; and Lawrence, R. W. “Electron Number Density Profiles for the Aeroassist Flight Experiment.” AIAA Paper 92-0804, 30th AIAA Aerospace Sciences Meeting, Reno, NV, Jan. 1992.

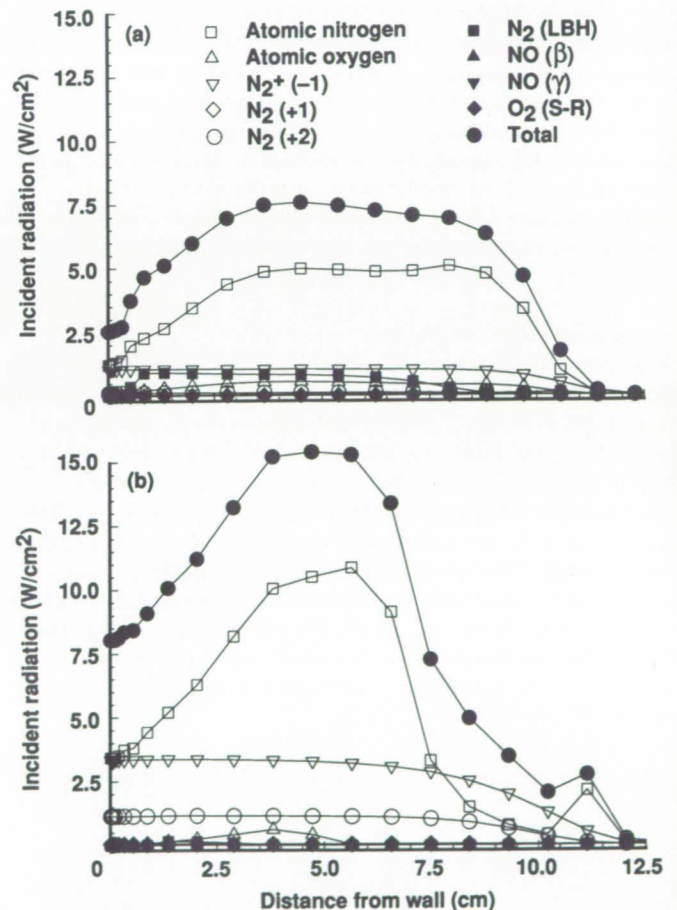

Incident radiative flux resulting from (a) the Kang and Dunn chemical-rate model and (b) Park's 1990 chemical-rate model.

# Incorporation of a Three-Dimensional Multistage Viscous Code into a Compressor Design System

Jeff L. Hansen, Principal investigator

Co-Investigator: John Adamczyk

General Motors Corporation, Allison Gas Turbine Division/NASA Lewis Research Center

## Research Objective

Emphasis on improved fuel efficiency, reduced weight, and lower life-cycle costs for gas turbine engines has produced aggressive compression system design, performance, and operability goals. To meet these goals, there is a critical need to incorporate a three-dimensional Navier–Stokes multistage flow model in the design process. The goal of this research is to use such a model to guide the design of a high-performance, highly loaded axial-flow multistage compressor.

## Approach

The aerodynamic design of a two-stage compressor was completed with a NASA-developed three-dimensional multistage viscous code (V-STAGE) with a traditional design system. The multistage code solves the three-dimensional average-passage Navier–Stokes equations, which are obtained from the Reynolds-averaged form of the equations. The resulting system of equations contain additional source terms to account for the presence of neighboring blade-rows. After parametric optimization with a through-flow analysis, the detailed airfoil design was achieved using an iterative loop between the through-flow analysis and a three-dimensional viscous isolated blade-row analysis and continued until a geometry that yielded acceptable aerodynamics was reached. An additional iteration loop involving the multistage code was used to make design modifications as a result of multistage effects on stage mismatch, blade-row interactions, mixing, and stall characteristics.

## Accomplishment Description

The code was implemented in the design process for a multistage compressor. Many design changes that normally would not have been made until after rig testing were made as a result of using this code. Extensive design modifications were made to eliminate suction-surface boundary-layer separation and improper exit-flow angles caused by multistage influences. The multistage code revealed a stage mismatch with the second rotor overflowing. The second rotor would unstart as the compressor was loaded above the design pressure ratio. Modifications to the rotors were made and an acceptable design was reached. The final design for this compressor was the result of extensive use of advanced computational fluid dynamics codes requiring approximately 300 Cray-2 hours.

## Significance

In the design process, it is important to incorporate a three-dimensional Navier–Stokes multistage flow model with the capability to model the complex interactive flow phenomena in multistage compressors. This allows the design of efficient, lightweight, and reliable compression systems with reduced development time and costs.

## Future Plans

Near term plans for this project are to complete the assembly of and test the two-stage compressor. This experimental data will be used to further calibrate the multistage code. A follow-on project may involve using this code to match a centrifugal compressor to the two-stage compressor to obtain a compact high-pressure-ratio compression system.

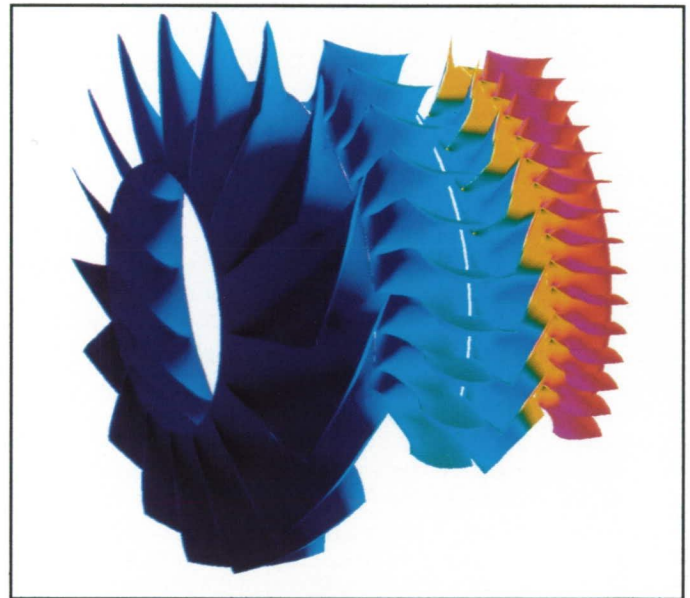

*Three-dimensional multistage Navier–Stokes analysis fully incorporated in the design process.*

# Swept-Wing Leading-Edge Transition

Julius E. Harris, Principal Investigator  
Co-Investigator: Venkit Iyer  
NASA Langley Research Center/ViGYAN Inc.

## Research Objective

To determine the effects on boundary-layer stability and transition due to single-parameter variations of the angle of attack, boundary-layer suction, wall cooling, and free-stream Reynolds number on the leading edge of a highly swept super-sonic wing.

## Approach

A 77.1 degree swept-leading-edge model undergoing tests at the NASA Langley Mach 3.5 Supersonic Low-Turbulence Pilot Tunnel is the geometry considered. The mean flow on this wing is obtained by solving the Navier-Stokes equations. The solution profiles are interfaced to a three-dimensional compressible version of the linear stability analysis code COSAL. The N-factors calculated are used as guidelines for predicting transition trends when the parameters are varied.

## Accomplishment Description

First, the N-factors and transition front corresponding to the nominal conditions of Mach 3.5, 0 degrees angle of attack,  $Re_\infty = 2.4$  million/foot, adiabatic wall, and zero suction were obtained. Results were then obtained with changes in angle of attack (1.5, 3.0, and 4.5 degrees). In spite of the larger cross flow, the transition front did not move upstream significantly. Results were obtained with two different suction distributions

that had a strong stabilizing influence. Two cases of wall cooling ( $T_w/T_\infty = 2.0$  and  $2.6$ ) were run, verifying the strong stabilization potential of wall cooling. Finally, results were obtained with  $Re_\infty$  values of 1.2, 4.0 and 6.0 million/foot. The flow was completely stable at the lower value. Significant upstream movement of the transition front was seen for  $Re_\infty = 6.0$  million/foot. Typical runs required approximately 30 megawords of memory and 2 CPU hours. Some fine-grid runs tripled the requirements.

## Significance

Results of this study are being used to determine the test envelope, instrumentation, and measurement requirements for the experimental study. The influence of these parameters on transition is important in the design optimization of natural or forced laminar-flow control on a swept supersonic wing.

## Future Plans

We will extend the calculations with multiparameter variations corresponding to actual test conditions and evaluate the results with experimental data.

## Publication

Iyer, V.; Spall, R. E.; and Dagenhart, J. R. "Computational Study of Transition Front on a Swept-Wing Leading-Edge Model." AIAA Paper 92-2630, June 1992.

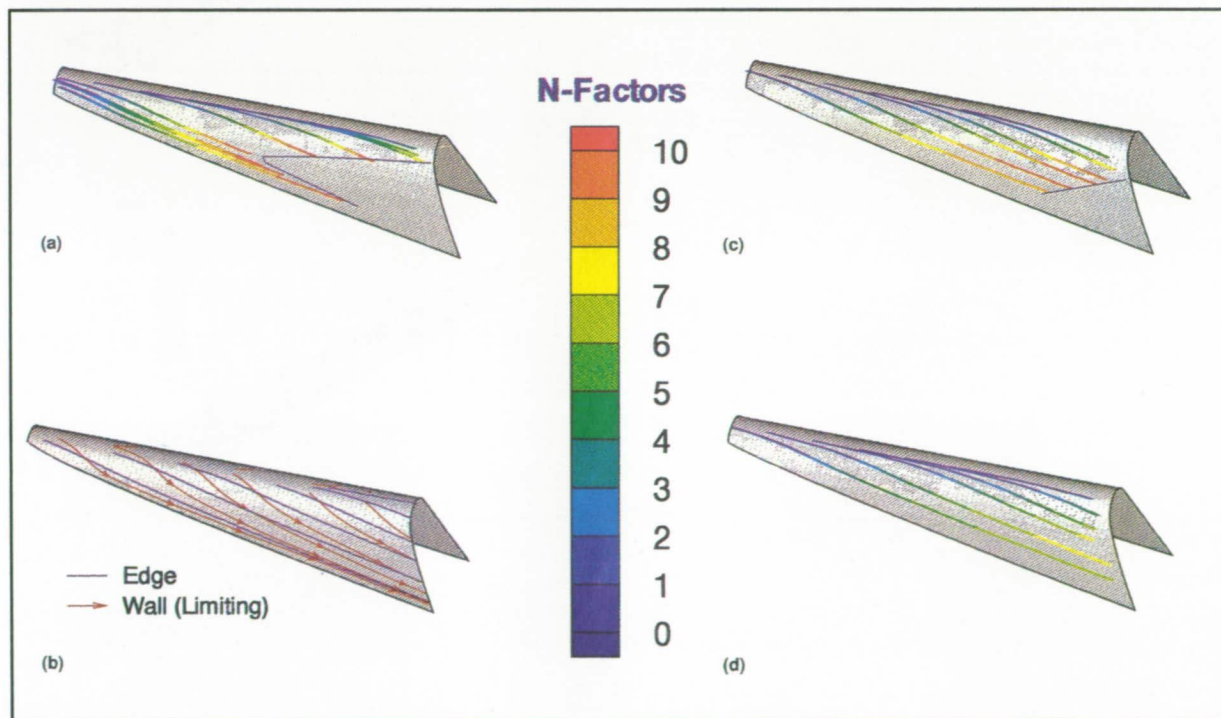

(a) Swept leading edge N-factors and transition front,  $M_\infty = 3.5$ ,  $\alpha = 0$  deg,  $Re_\infty = 2.4 \times 10^6$ , wall cooling and suction off. (b) Streamlines for  $\alpha = 0$  deg case. (c) N-factors and transition front with suction ( $q_s = 0.0004$ ). (d) N-factors with  $Re_\infty = 1.2 \times 10^6$ .

# Radiation Transport around Axisymmetric Blunt-Body Vehicles

Lin C. Hartung, Principal Investigator  
NASA Langley Research Center

## Research Objective

To develop a practical method to compute radiation transport in complex flow fields without invoking the tangent slab approximation.

## Approach

A modified differential approximation (MDA) employs the P-1 approximation to model the radiation transport in a medium without accounting for wall emission and reflection. This reduces the governing integro-differential equations to coupled partial differential equations. A numerical finite-volume solution method is developed to obtain the radiative-flux incident on the wall and the radiative-flux divergence in the medium.

## Accomplishment Description

The MDA method has been applied to two forebody aerobrake flow fields. Comparisons with tangent slab results suggest the MDA method is valid. The computer time required by the method is within reason.

## Significance

Radiative heating is a concern for large-scale or large-velocity missions, particularly if unshielded payloads are placed behind a heat shield. This method offers the potential to predict the radiative heat load on such vehicles.

## Future Plans

We will continue to improve the efficiency and robustness of the method and apply it to wake flows.

Mars return condition:

$V = 12 \text{ km/s}$   
 $H = 80 \text{ km}$   
 $R_n = 1 \text{ m}$   
60° sphere cone

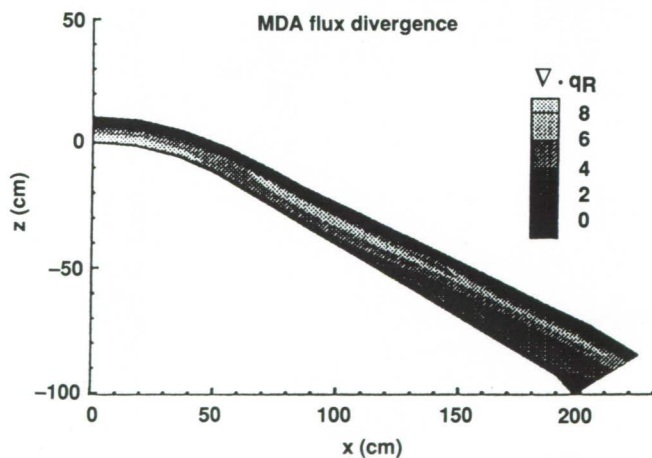
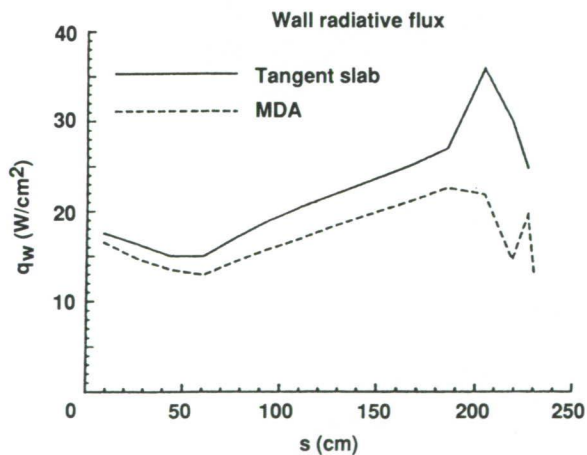

Mars return conditions;  $V = 12 \text{ km/sec}$ ,  $H = 80 \text{ km}$ ,  $R_n = 1 \text{ m}$ , 60 degree sphere cone.

# New Approach for Transitional-Flow Modeling

H. A. Hassan, Principal Investigator  
 Co-Investigators: T. Wayne Young and Eric S. Warren  
 North Carolina State University

## Research Objective

To develop models similar to available turbulence models for studying transitional flows.

## Approach

If  $\gamma$  represents the fraction of time the flow at a given point is turbulent, then transitional stresses can be represented as

$$\overline{(u_i' u_j')} = \gamma \overline{(u_i' u_j')}_t + (1 - \gamma) \overline{(u_i' u_j')}_l + \gamma(1 - \gamma) \Delta U_i \Delta U_j$$

$$\Delta U_i = U_{t,i} - U_{l,i}$$

where subscripts  $r$ ,  $t$  and  $l$  indicate, respectively, transitional, turbulent, and laminar or non-turbulent. Reynolds-averaged equations using a one-equation model and a stress model were used to calculate the turbulent components. A number of procedures were used to calculate the contribution of the large structures (the term involving  $\Delta U_i \Delta U_j$ ).

## Accomplishment Description

Emphasis is placed on predicting the measurements of Schubauer and Klebanoff, which consist of velocity and stream-

wise intensities. A procedure was developed for the incorporation of some of the linear stability theory results in order to estimate the contribution of the laminar or non-turbulent terms. The results showed that the non-turbulent and large-eddy components have a considerable influence on the streamwise intensities, but little influence on the shear stress. Moreover, predictions of the one-equation model were as good as those obtained for the stress model. The accompanying figure shows a comparison between theory and experiment. Each job requires about 10 megawords of memory and 2.5 CPU hours to converge.

## Significance

Recent research on the National Aero-Space Plane identified the need to develop computational tools for the prediction of high-speed transitional flows. Understanding transitional flows has a major impact on the feasibility of this plane.

## Future Plans

Work is focusing on pressure gradient and Mach number effects.

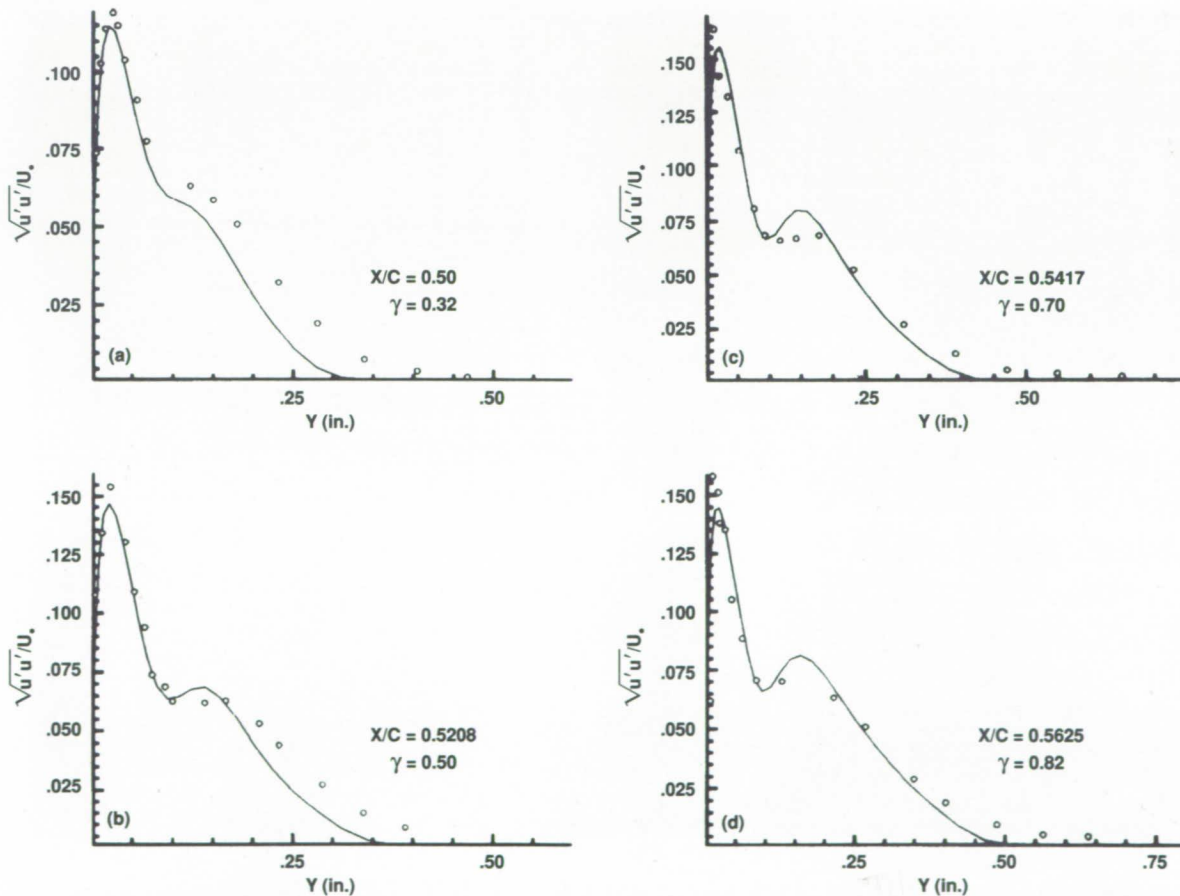

Streamwise turbulent intensities.

# Hot-Gas Ingestion by a Short Takeoff and Vertical Landing Aircraft in Ground Proximity

James D. Holdeman, Principal Investigator

Co-Investigators: David M. Fricker and S. Pratap Vanka

NASA Lewis Research Center/University of Illinois, Urbana/Champaign

## Research Objective

To simulate the three-dimensional turbulent flow around a short takeoff and vertical landing (STOVL) aircraft in ground proximity. Studying the gas environment is part of the effort to understand hot-gas ingestion for advanced STOVL aircraft.

## Approach

A state-of-the-art, multigrid, three-dimensional, Reynolds-averaged, Navier–Stokes flow solver with a two-equation turbulence model is used to predict the hot-gas environment around a STOVL aircraft operating in ground proximity.

## Accomplishment Description

Work included modifying the three-dimensional multigrid computational fluid dynamics (CFD) code and running more parametric calculations of test cases. These calculations included variations of ground proximity, head-wind speed, turbulence intensity, and thrust-splay angle. Over 30 cases, each involving over 200,000 grid points, were computed. A typical test case required about 1.5 Cray Y-MP hours and 16 megawords of memory. Qualitatively, the results compare well with experi-

mental data. A number of interesting flow phenomena have been noticed in the numerical results. Other work included revising and debugging the CFD code from a cartesian geometry to a curvilinear geometry.

## Significance

The problem of hot-gas ingestion for STOVL aircraft has typically been solved by a combination of experience and trial and error. With the advent of highly efficient flow solvers, CFD is becoming a viable engineering tool in the study of hot-gas ingestion problems and STOVL aircraft design.

## Future Plans

Testing of the curvilinear version of the multigrid flow solver will be completed and the code will be used to study the hot-gas environment of an advanced STOVL design. This will be an improvement over the generic cartesian geometry used before. The studies will include parametric variations similar to those done with the cartesian code, but will involve a much more realistic aircraft geometry to investigate the effects of aircraft shape.

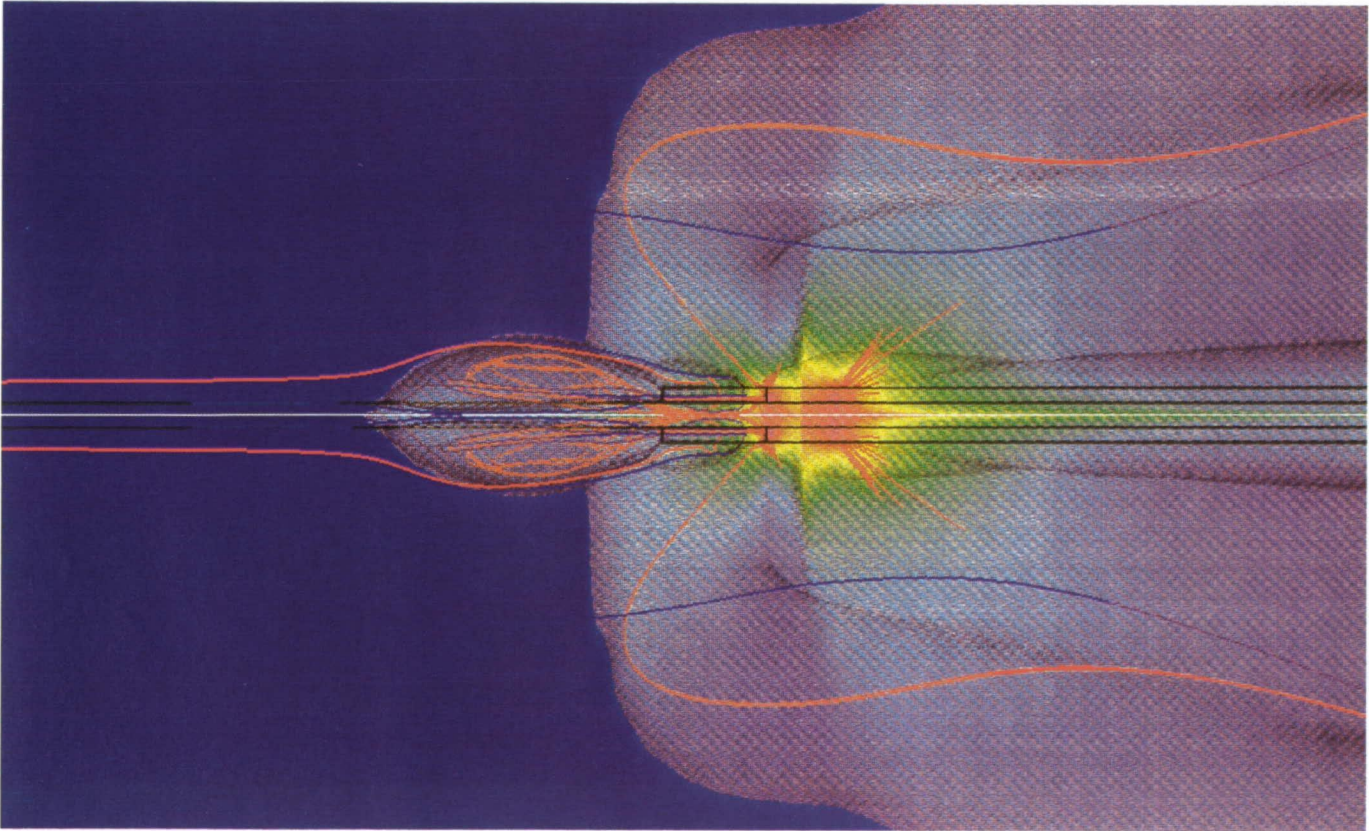

*Overhead view of ground temperature contours, select particle traces, and a three-dimensional isotherm. The lighter area reveals widespread influence of the hot exhaust gases, while the particle traces (red and blue lines) and the isotherm (light red surface) indicate the deflection of the ambient flow.*

# Full Navier–Stokes Analysis of a Three-Dimensional Scramjet Inlet

Yeu-Chuan Hsia, Principal Investigator

Co-Investigators: Endwell Daso and Sukumar Chakravarthy

Rockwell International, Rocketdyne Division/Rockwell International Science Center

## Research Objective

To analyze the flow structures in practical high-speed inlets and to determine their effects on the inlet performance. The present work is to validate the computational fluid dynamics code on a three-dimensional scramjet inlet and to evaluate the applicability of the full Navier–Stokes solution on inlet performance predictions.

## Approach

The unified solution algorithm code was used to compute the inlet flow field. The code solves full or Reynolds-averaged Navier–Stokes equations based on finite-volume discretization using the total-variation-diminishing formulation. Perfect gas relation was used as the thermodynamic property. The turbulence effect was simulated by the Baldwin–Lomax algebraic turbulence model. The code also possessed a multi-zone grid bookkeeping capability.

## Accomplishment Description

A fixed-geometry sidewall compression inlet was computed with a Mach 5 inflow. For 0 angle of attack and yaw, double symmetry was assumed and only one quarter of the flow path was computed. In order to simulate the inlet spillage properly, the external flow region was also computed. A grid consisting of 10 zones with 242,800 nodes was used. The solutions were obtained by a time marching method. A laminar-flow solution was computed first. The turbulent-flow solution was computed with a boundary layer transition location estimated by comparing the laminar solution and test data. Each solution took about 60 Cray Y-MP hours and 16 megawords of memory.

## Significance

Both the laminar- and turbulent-flow solutions closely predicted the overall inlet performance in terms of air-capture ratio and total-pressure recovery. However, comparing the flow-field data, only the turbulent-flow solution showed good agreement. The laminar-flow solution had boundary-layer separations that might lead to inlet unstart. Hence, the inlet functionality should be assessed by not only the performance parameters, but also the flow structures.

## Future Plans

More validation computations will be done on inlets with heat-transfer and skin-friction data. Time-accurate computations will be carried out to simulate the inlet unstart.

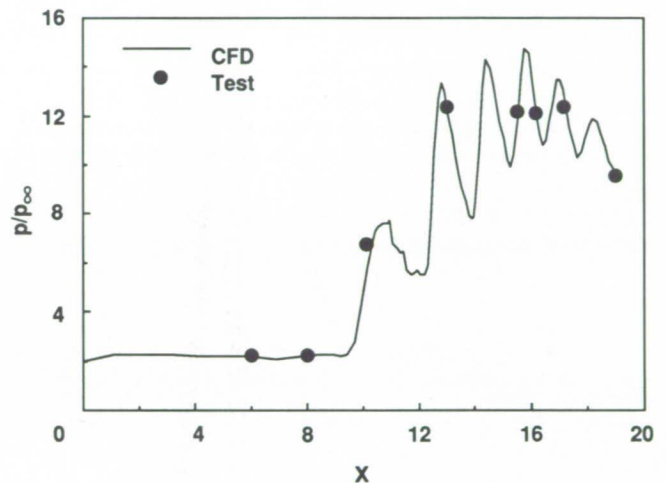
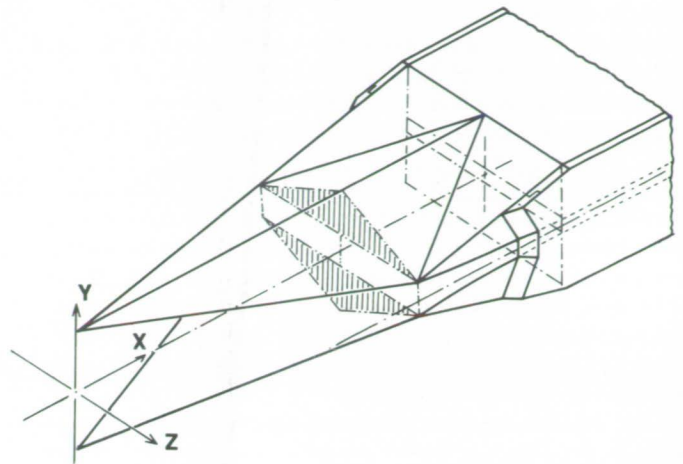

Mach 5 computations of the sidewall compression inlet.

# High Angle-of-Attack Missile Aerodynamics

Carl T. Hsieh, Principal Investigator  
Naval Surface Warfare Center

## Research Objective

To evaluate numerical simulations of vortical flow over an ogive cylinder and to numerically investigate incompressible, three-dimensional, laminar-flow structure about a hemisphere cylinder at large incidences.

## Approach

The CFL3D code was used to simulate supersonic flow over an ogive cylinder at  $\alpha = 18$  degrees and Mach 3.5, and incompressible laminar flow over a hemisphere cylinder at  $\alpha = 10, 30,$  and  $50$  degrees. Solutions were compared to experimental data and observations.

## Accomplishment Description

The CFL3D code has been adapted to simulate both laminar and turbulent flows over an ogive cylinder with a Reynolds number of 1.23 million based on diameter. A C-grid with points of  $91 \times 68 \times 75$  was used. The turbulence model used was the Baldwin–Lomax model modified by Degani and Schiff for vortical flow. Tests of the effects of grid sensitivity were conducted and an optimum grid distribution was selected. Comparisons of cross-flow surface pressure at four axial stations, Pitot pressure along the radial lines, and Pitot pressure contours at the axial station  $x/D = 11.5$  (see accompanying figure), where  $x$  is the distance from the nosetip and  $D$  is the cylinder diameter, were presented. Good qualitative prediction was found for flow

features such as the leeside vortex, the shear layer emanating from the separation point, the bow shock, the cross-flow shock, and the shock atop the vortex at far downstream. The laminar solution agrees better with the experiment; however, the point of separation predicted is farther leeward than experiment. For the incompressible laminar flow over the hemisphere cylinder at incidences, a C-grid with points of  $101 \times 68 \times 75$  was used. Converged solutions were obtained, but analysis and comparison with experiments have not yet been performed. Computation requires about 30 Cray-2 hours and 24 megawords of memory.

## Significance

Above an incidence of 5–10 degrees, the flow in the leeside of a circular body separates to form vortices. The interaction of the leeside vortical flow with control surfaces contributes to the highly nonlinear aerodynamics exhibited by these missiles. Prediction of vortical flow is important in the design of a new generation of highly maneuverable missiles.

## Future Plans

The CFL3D code will be used to compare two flux-splitting schemes of Roe and Van Leer for steady flow, and study unsteady/transient flow about a pitching missile body. Computation of a missile with fins will also be performed.

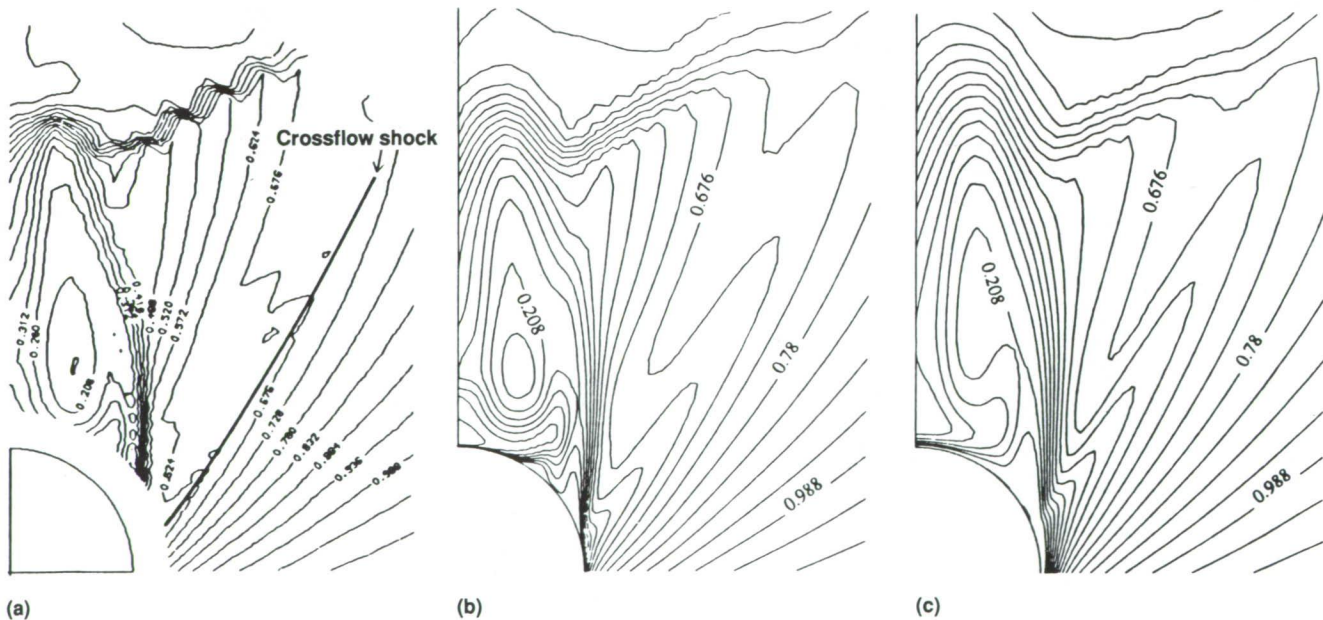

Pitot pressure contours at  $x/D = 11.5$ ; (a) experiment, (b) laminar solution, (c) turbulent solution.

# Submarine-Appendage Design and Turbulence Modeling

Thomas T. Huang, Principal Investigator

Co-Investigators: Michael Griffin, Jeff Tsai, William Smith, and Dane Hendrix

Naval Surface Warfare Center/Jason Associates/Scientific Research Associates, Inc./MCAT Institute

## Research Objective

To design a small appendage on the underside of a submarine bow using an incompressible Reynolds-averaged Navier–Stokes (RANS) flow solver for the flow analyses. The appendage is required to produce a minimum variation in pressure and to induce a minimum longitudinal vorticity in high-Reynolds-number flow conditions. The development of a more accurate algebraic turbulence model in areas of separated flow will also be addressed.

## Approach

Given the original design and various constraints, a small appendage on the underside of a submarine bow has been redesigned using the incompressible RANS flow-solver, IFLOW.

## Accomplishment Description

The calculated pressure coefficient on the hull in the vicinity of the appendage and the longitudinal vorticity component downstream from the appendage for both the original and the modified designs are shown in the accompanying figure. The modified design produces a significantly smaller variation in pressure on the appendage and induces less longitudinal vorticity. Typical flow analyses required 10 megawords of memory and 30 Cray Y-MP minutes. Over 100 different design modifications were considered and analyzed. This is an important demonstration of the capability of the current RANS flow

solver to aid in the design of critical components of naval ships and weapons. In additional research, a new algebraic turbulence model has been developed for the prediction of three-dimensional separated flows. Preliminary results indicate that the new turbulence model predicts flow-field quantities for an unappended submarine with greater accuracy than previously developed models. Typical flow analyses required 5 megawords of memory and 10 Cray Y-MP minutes.

## Significance

Submarine design has relied on a combination of classical analysis, potential-flow computation, and viscous–inviscid interactive computation. The current RANS solver provides fast and accurate flow-field analyses and previously unobtainable detailed information about longitudinal vortices, flow non-uniformity at the propeller plane, forces, and moments at large angle of attack during maneuvering. This solver will make it possible to produce inexpensive and efficient submarine designs.

## Future Plans

We will further develop turbulence models for submarines and complete validation of IFLOW and additional applications of IFLOW to design components critical to naval fleets. A method for computing three-dimensional flows about an arbitrary ship form advancing in regular waves is being developed. Calculations to test and validate this method will be performed.

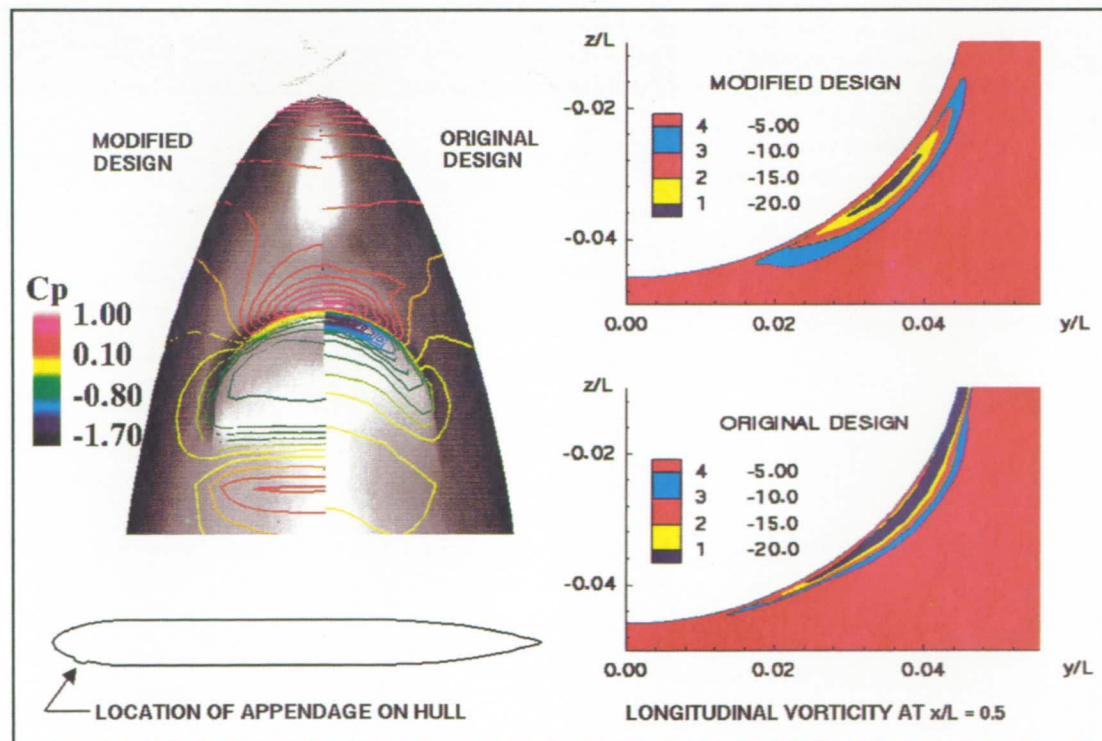

Design of a submarine appendage using the Reynolds-averaged Navier–Stokes flow solver.

# Generic National Aero-Space Plane Fuselage Configuration Study

Lawrence D. Huebner, Principal Investigator

Co-Investigator: Kenneth E. Tatum

NASA Langley Research Center/Lockheed Engineering and Sciences Company

## Research Objective

To develop the capability to predict the three-dimensional flow field about a generic National Aero-Space Plane (NASP) fuselage and engine module under simulated power conditions and to determine the three-dimensional effect of using a tetrafluoromethane ( $\text{CF}_4$ ) and Argon (Ar) gas mixture as the exhaust simulant instead of air.

## Approach

For the two exhaust-gas simulations (air or  $\text{CF}_4$ -Ar), three-dimensional viscous flow fields were computed by solving the parabolized Navier-Stokes equations using the General Aerodynamic Simulation Program. The resulting flow-field quantities, surface quantities, and integrated forces and moments were examined to quantify differences between the exhaust-gas simulations.

## Accomplishment Description

Computational solutions for the fuselage and engine module were obtained for the two types of exhaust. The first solution was with both the external and internal flow represented by air (perfect gas) and the second with the external flow represented by a mixture of nitrogen and oxygen (simulating air) and the internal exhaust simulant with  $\text{CF}_4$ -Ar. All four gas species were present in the aftbody zone. Solutions were computed at  $M_\infty = 6.0$ ,  $Re_\infty = 1.0 \times 10^6/\text{ft}$ ,  $\alpha = 0$  degrees, and static nozzle pressure ratios of 135 and 232. The accompanying figure shows surface pressure contours and flow-field Mach number contours on the model centerline and downstream grid planes. The figure inset shows a comparison of plume expansion at the end of the model for the two exhaust gases. For both cases, the plume has expanded beyond the edge of the body, indicating that the plume will likely impact lifting and control surfaces that are on the fuselage. The  $\text{CF}_4$ -Ar plume expands farther from the aftbody than the air plume, although some of the air plume expands to Mach 8, well beyond the free-stream Mach number. Typical-air parabolized Navier-Stokes (PNS) solutions required about 9 megawords of memory and 8.3 Cray Y-MP hours, while the multiple-species PNS solutions required 12 megawords of memory and 9.2 Cray Y-MP hours.

## Significance

There are differences in aftbody flow fields. Also, regardless of the exhaust gas modeled, the plume extends beyond the edge of the aftbody and will likely impact the lifting and control surfaces of a NASP vehicle.

## Future Plans

Following minor grid improvements on the existing computational model, cases will be computed on the configuration with the wings installed to confirm the plume effects on lifting and control surfaces. Additional solutions will be obtained by varying the inlet representation and free-stream and internal (jet) conditions.

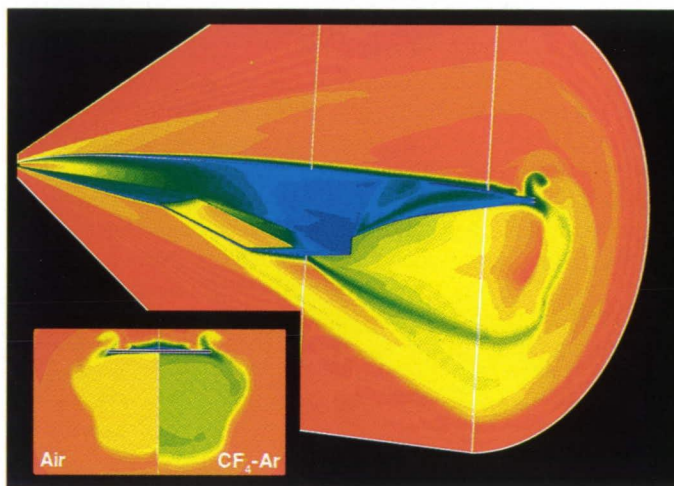

Computational solution of a National Aero-Space Plane fuselage configuration. Tetrafluoromethane and argon exhaust solutions computed at  $M_\infty = 6.0$ ,  $Re_\infty = 1.0 \times 10^6/\text{ft}$ ,  $\alpha = 0$  degrees, and static nozzle pressure ratio = 232, show surface pressures (blue = 0.05 psi, red = 2.50 psi) and flow-field Mach number contours (blue = 0.0, red = 6.0). The inset shows streamwise velocity-component contour comparisons at the fuselage trailing edge for the two types of exhaust simulations.

# Hypersonic Scramjet and Detonation Flows

Joseph W. Humphrey, Principal Investigator

Co-Investigators: Darrell W. Pepper, Thomas H. Sobota, Frank P. Brueckner, Barry Dyne, and Juan C. Heinrich  
Advanced Projects Research, Inc./University of Arizona/NASA Langley Research Center

## Research Objective

To develop the capability to analyze and design a scram-accelerator technology demonstrator. A scramaccelerator is a projectile launching device that uses scramjet propulsion and oblique detonation to accelerate projectiles. Hypersonic chemically reacting flow is encountered in the high Mach number (5–16) regimes.

## Approach

A finite-element Navier–Stokes solver in both two and three dimensions specifically oriented toward solving compressible high-Mach-number scramjet-type flow fields was developed to incorporate finite-rate chemistry.

## Accomplishment Description

A two- and three-dimensional finite-element model for viscous high-speed compressible flow is being applied to the scram-accelerator configuration. The scheme is based on a shock-capturing Petrov–Galerkin formulation where a different anisotropic diffusion is added for each conservation equation. A precise criterion is available to choose the direction and the magnitude of the added diffusion for superior stability and accuracy. The semi-discrete Petrov–Galerkin approximation has been implemented in conjunction with a lumped-mass second-order Runge–Kutta time-integration scheme. It is based on isoparametric bilinear elements in space and a weighted-

residuals formulation where the weighting functions for the convective terms are different for each transport equation. The finite-rate chemistry model developed by D. T. Pratt at the University of Washington has been incorporated into the flow solver. Reacting-flow results are obtained by operator splitting or by a method of fractional steps. Time-accurate calculations require an iteration at each time step. This approach allows independent development of flow and chemistry solvers, using methods optimal for each system. A typical axisymmetric inviscid reacting-flow simulation requires approximately 2–3 Cray-2 hours and 1 megaword of memory.

## Significance

NASA Langley hopes to develop a hypersonic ballistic range for ground-based free-flight hypersonic testing. The scram-accelerator propulsion technology is also a direct benefit to the National Aero-Space Plane scramjet efforts.

## Future Plans

Plans include implementation of adaptive gridding, continued parametric studies of the scramaccelerator, dynamic design iteration of hypersonic nozzles, continued optimization through vectorization and parallelization, three-dimensional studies of spinning projectiles, fin effects and stabilization, and sabot–projectile separations.

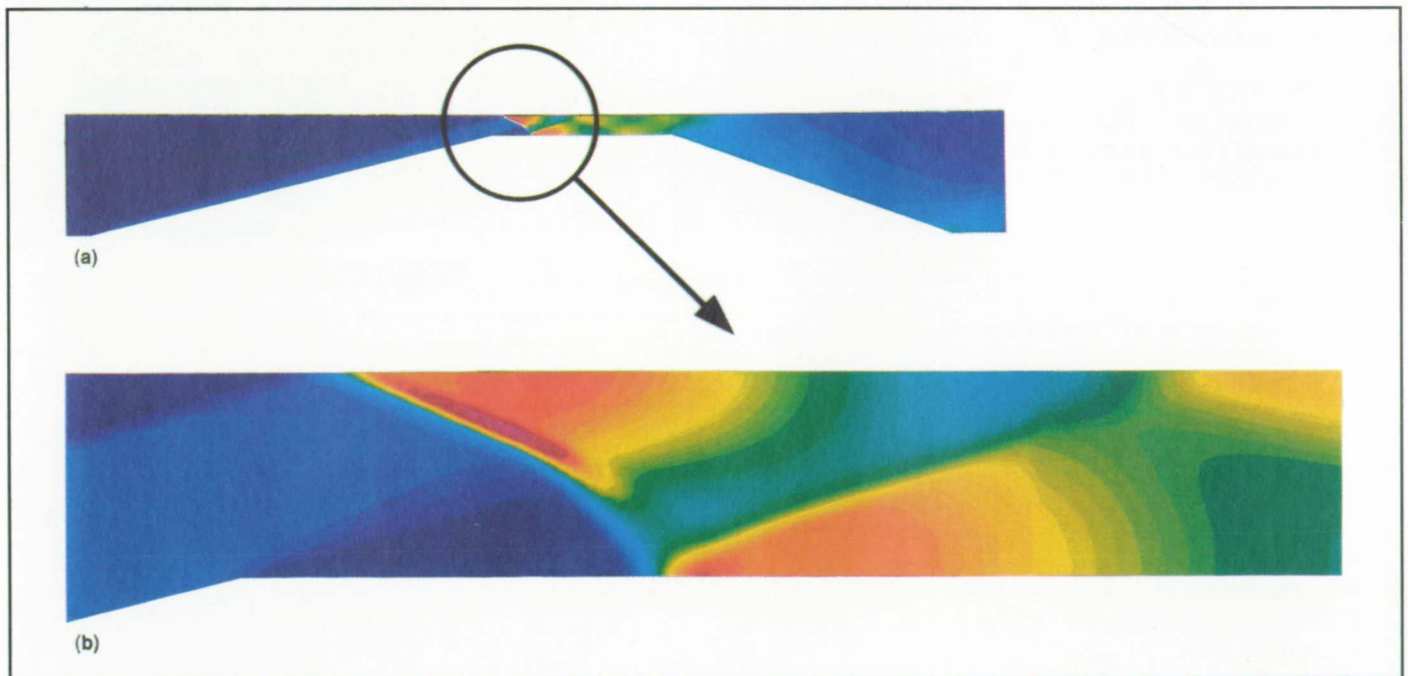

*Mach 8 scramaccelerator simulation: (a) pressure contours around an entire projectile, and (b) detail of a multidimensional oblique detonation wave and flow accommodation in flow annulus.*

# Coherent-Structure Interactions with Turbulence

Fazle Hussain, Principal Investigator  
Co-Investigator: Mogens V. Melander  
University of Houston/Southern Methodist University

## Research Objective

To investigate the core dynamics of an isolated coherent structure and its interactions with turbulence by simulating idealized configurations.

## Approach

Direct numerical simulations of the three-dimensional time-dependent incompressible Navier–Stokes equations are utilized. The simulations use highly accurate and efficient pseudospectral Fourier methods. Critical parameters such as Reynolds number, amplitude of core nonuniformity, and intensity of background turbulence are varied.

## Accomplishment Description

Using an axisymmetric vortex tube with a nonuniform cross section, we have shown that core dynamics lead to axial waves. The frequency of the waves decreases as the Reynolds number increases, reaching a finite value in the inviscid limit and the wave amplitude decays slowly for high Reynolds numbers. The little-used, powerful mathematical approach of complex helical wave decomposition explains core dynamics better than coupling between meridional flow and swirl. Simulations of a vortex tube with a nonuniform cross section in the presence of background turbulence showed that, contrary to the usual belief, small scales can also cause instability of the large-scale structures, which energizes and sustains the small scales. Coherent structures are helical and the helicity integral can become nonzero during simple viscous decay. These runs typically required 4–8 Cray-2 hours and 10 megawords of memory.

## Significance

Results show that core dynamics must always be modeled and that simulations that neglect them are suspect. We propose a new physical model of cascade that questions the concept of local isotropy.

## Future Plans

We will validate our conceptual model of cascade through more high-resolution simulations. We have developed a code based on complex helical wave decomposition that will be used to investigate the dynamics of vortex rings with swirl and vortex breakdown.

## Publications

1. Melander, M. V. and Hussain, F. "Coherent Structure Dynamics: Interaction between Large and Fine Scales." *8th Symp. Turb. Shear Flow*. Munich, GE, Sept. 1991.
2. Melander, M. V.; Hussain, F.; and Basu, A. "Breakdown of a Circular Jet into Turbulence." *8th Symp. Turb. Shear Flow*. Munich, GE, Sept. 1991.

3. Hussain, F. and Melander, M. V. "Understanding Turbulence via Vortex Dynamics." In *Studies in Turbulence*, eds. Gatski et al. Springer Verlag, 1991.
4. Hussain, F. and Melander, M. V. "New Aspects of Vortex Dynamics: Helical Waves, Core Dynamics, Viscous Helicity Generation, and Interaction with Turbulence." In *Topological Aspects of the Dynamics of Fluids and Plasma*, eds. H. K. Moffatt et al. Accepted by Kluwer Publ., 1992.

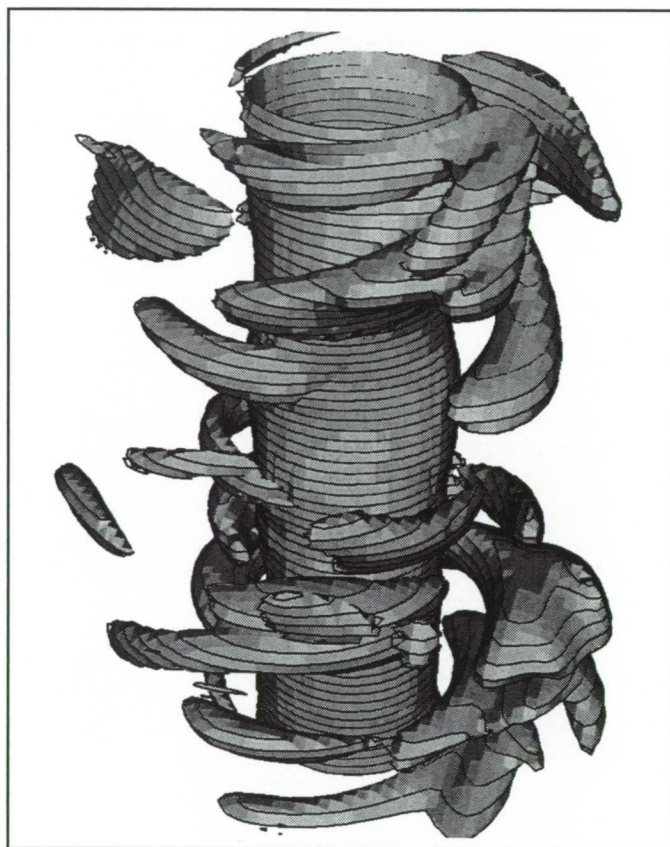

Organization of small scales into spirals around a nonuniform cross-section vortex tube.

# Chemically Reacting Free-Shear Flows

Fazle Hussain, Principal Investigator  
Co-Investigators: Ralph Metcalfe and Fernando Grinstein  
University of Houston/Naval Research Laboratory

## Research Objective

To investigate the role of coherent structures formed by the primary and secondary instabilities (spanwise "rolls" and streamwise counter-rotating "ribs") in chemically reacting turbulent free-shear flows and to determine how they effect important phenomena such as species transport, reaction rates, and distribution of product.

## Approach

Using spectral numerical methods, direct simulations are employed to solve the time-dependent incompressible Navier–Stokes equations in two and three spatial dimensions coupled with multiple reaction–diffusion equations governing the chemical reactions. Important parameters such as initial perturbations and convective and diffusive Damköhler numbers are varied to determine the effect on the reaction.

## Accomplishment Description

New simulations have extended the range of parameters under investigation, including the addition of temperature-dependent reaction rates. We have shown that the presence of ribs can, depending upon the Schmidt number ( $Sc$ ), enhance or retard chemical reactions. At a  $Sc = 0.70$  the presence of ribs enhances the generation of product by increasing the surface area of the reaction zone, whereas at  $Sc = 0.07$  the reaction is diffusion-dominated and flame shortening occurs in the ribs, thereby reducing the reaction zone. Simulations performed at higher Schmidt numbers (up to 5.0) show that reactants in the paired cores are segregated by a thin product layer, thus preventing interdiffusion of reactants. This mechanism is different from flame shortening for  $Sc < 1$  where there is an exhaustion of reactants within the rolls. Temperature-dependent simulations have shown that ribs sustain reactions while the braid region is unable to keep pace with the influx of reactants and is cooled nearly to the activation temperature. Typical high Schmidt number three-dimensional runs required 25 Cray Y-MP hours and 80 megawords of memory to reach pairing.

## Significance

Combustion efficiency can be optimized through the artificial excitation of coherent structures. The role of ribs in generating product is important. At higher Schmidt numbers, the existence of another reaction-controlling mechanism has been demonstrated. In the temperature-dependent case, the presence of reaction within the ribs may serve as a mechanism to ignite mixed reactants at later times.

## Future Plans

We plan to further investigate the role of coherent structures in reacting flows, including the importance of the phase of the unstable modes and oblique modes. We will continue to investigate temperature-dependent reactions and heat release and compressibility effects.

## Publication

Metcalfe, R. W.; Hussain, F.; and Park, K. H. "Role of Rolls and Ribs in Reacting Mixing Layers." *8th Symp. Turb. Shear Flow*. Munich, GE, Sept. 1991.



Contours of reactant concentration at the first pairing for two-dimensional simulation with cold reaction;  $Sc = 0.5$ . The highest contour level is 0.92, the lowest is 0.27, and the interval is 0.054.

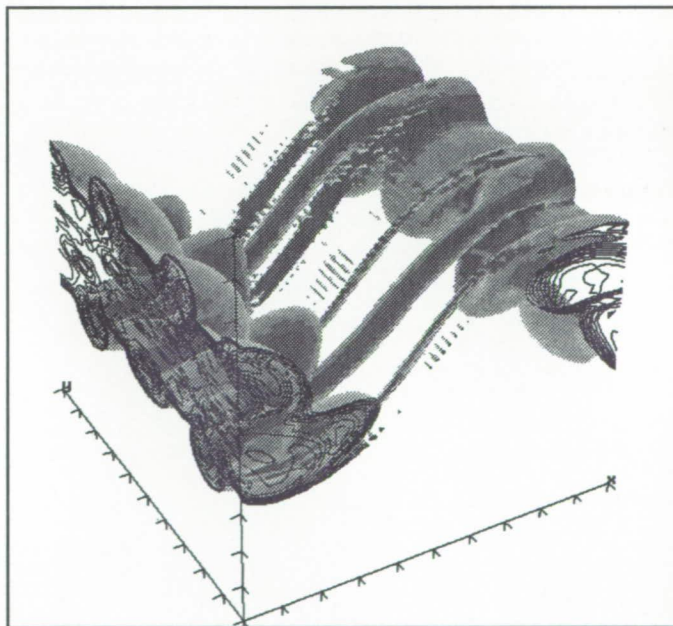

Iso-surface of temperature for temperature-dependent reaction at pairing time. The surface is at 50% of peak.

# Aero-Assisted Orbital Transfer Vehicle Flow Fields

Scott T. Imlay, Principal Investigator

Co-Investigators: Donald W. Roberts and Moeljo Soetrisno

Amtec Engineering, Inc.

## Research Objective

To develop a computational fluid dynamics (CFD) code for the analysis of rarefied flow about hypersonic vehicles.

## Approach

A three-dimensional Navier–Stokes code with finite-rate chemistry is modified to solve the two-dimensional Burnett equations with rotational nonequilibrium. The Burnett equations are more accurate than the Navier–Stokes equations at low densities where the continuum assumption is beginning to fail. Surface-slip boundary conditions are used along the walls.

## Accomplishment Description

The Burnett equations with rotational nonequilibrium are solved using a hybrid implicit method. The inviscid and Navier–Stokes terms are solved using an implicit upwind scheme based on Yoon’s LU-SGS algorithm. The Burnett terms are treated implicitly using two steps of a line Gauss–Seidel relaxation. The code has been applied to the calculation of a one-dimensional shock wave structure and two-dimensional hypersonic flow past a two-dimensional circular leading edge. The accompanying figure compares the translational temperature contours calculated using the Navier–Stokes and Burnett equations for a circular leading edge with a Knudsen number of 0.5 and a Mach number of 20. The shock wave is much more dispersed with the Burnett equations than with the Navier–Stokes equations.

## Significance

Since wind tunnel simulations of hypersonic vehicles is difficult and expensive, future hypersonic vehicle design will increasingly depend on CFD flow analysis. Most CFD codes solve the Navier–Stokes equations. For low density flows, however, the Burnett equations are more accurate.

## Future Plans

The usefulness of the hypersonic flow analysis code will be increased by adding catalytic wall-boundary conditions.

## Publication

Imlay, S. T. “Solution of the Burnett Equations for Hypersonic Flows near the Continuum Limit.” AIAA Paper 92-2922, July 1992.

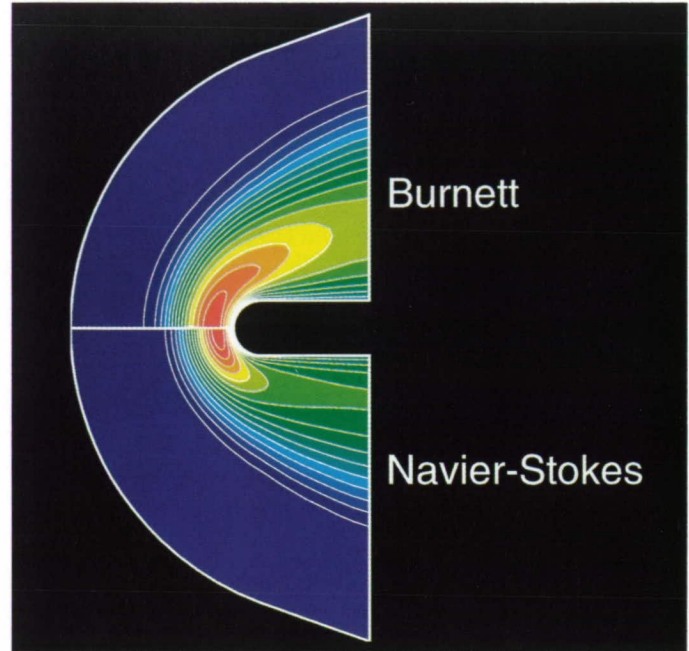

*Comparison of the translational temperature contours for a circular leading edge; Knudsen number = 0.5; Mach = 20.*

# Wing–Nacelle–Pylon Installations

Gregory A. Intemann, Principal Investigator  
Co-Investigator: Todd R. Michal  
Douglas Aircraft Company/McDonnell Aircraft Company

## Research Objective

To perform initial calibrations and validations of a multi-zone Navier–Stokes code for use in predicting powered propulsion-system installation effects for wing–nacelle–pylon configurations on transport aircraft.

## Approach

The three-dimensional Navier–Stokes code used for this study was NASTD. The code algorithm is a time-dependent finite-volume implicit scheme based on upwind differencing. A Baldwin–Lomax turbulence model was used in this study. To identify potential areas of propulsion–airframe interaction and jet interference, the wing–nacelle–pylon combination results were compared to wing-alone and isolated nacelle–pylon results. The computational results were also compared to flight-test data.

## Accomplishment Description

Several cruise angles of attack and corresponding engine-power settings were evaluated using a representative transport aircraft wing–nacelle–pylon configuration in conjunction with two different engine configurations. The wing-alone and isolated nacelle–pylon configurations were also analyzed at typical cruise conditions. Comparisons between flight-test results and wing–nacelle–pylon computations indicate good agreement in

the nacelle–pylon region. The wing–nacelle–pylon mesh is comprised of 25 grid zones and contains approximately 1.3 million points. A typical solution with this mesh requires 16 megawords of memory and approximately 25 Cray Y-MP hours.

## Significance

NASTD analyzes transport aircraft wing–nacelle–pylon configurations with power effects. Good correlation of the NASTD predictions with flight-test data lends confidence to the computed solutions. Comparisons between the isolated and wing-mounted nacelle–pylon NASTD solutions predict sizeable wing influence on the pylon shelf and core exhaust flow fields. The pylon-shelf designs developed using a typical wind tunnel test set-up, where an isolated (powered) nacelle–pylon without a wing is used, may not perform satisfactorily in the presence of the wing.

## Future Plans

We will continue to apply the NASTD code to predict jet-interference effects for wing-mounted nacelle–pylon installations to establish the changes in interference characteristics due to increasing engine-bypass ratio (up to 15), and due to nacelle positioning variations (longitudinally and vertically).

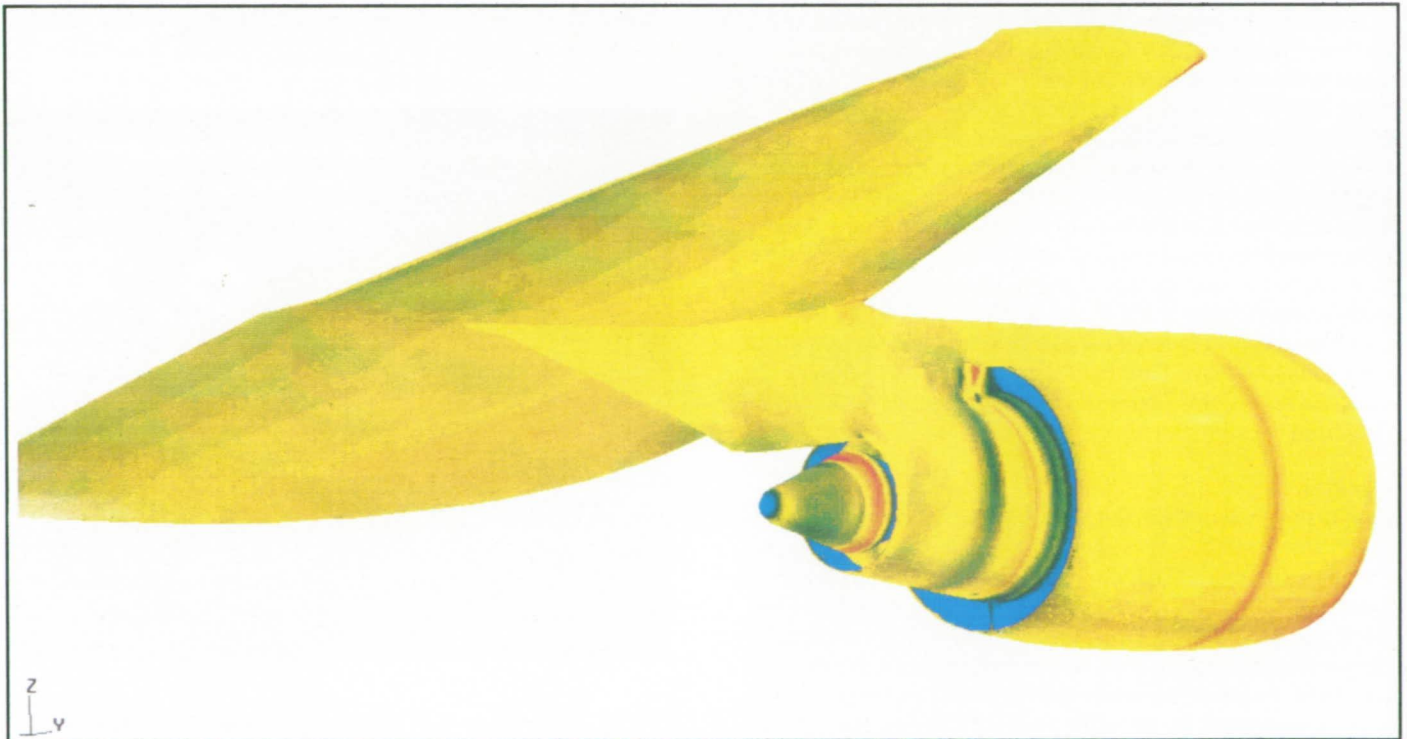

*NASTD-computed surface-pressure contours on a transport aircraft wing–nacelle–pylon; Mach = 0.828,  $\alpha$  = 2.85 degrees, and altitude = 35,000 ft.*

# Analysis of High-Speed Civil Transport Configurations

Kenneth M. Jones, Principal Investigator

Co-Investigators: Victor R. Lessard and M. A. Takallu

NASA Langley Research Center/ViGYAN, Inc./Lockheed Engineering and Sciences Company

## Research Objective

To determine the accuracy, applicability, and efficiency of three NASA Langley three-dimensional Navier–Stokes solvers for analyzing the low-speed aerodynamic characteristics of High-Speed Civil Transport (HSCT) configurations.

## Approach

The three-dimensional Navier–Stokes codes (CFL3D, TLNS3D and FMC1) were used to analyze an HSCT configuration operating at low speed. The codes were run using the same grid, and comparisons were made of the results obtained from the three different codes.

## Accomplishment Description

The analyzed HSCT configuration was optimized for supersonic cruise at Mach 3. The three codes were used to analyze the configuration at subsonic free-stream conditions (Mach 0.3). All codes obtained converged solutions on the vehicle, but with varying degrees of accuracy and run times. The grid did not have optimal grid-clustering near the body for the free-stream initial conditions. A new grid has been generated and the analysis will be run again. Even with a slightly coarse grid, the results from the CFL3D code compared well with the available experimental data. The analyzed grid had approximately 850,000 points and a typical run required about 40 megawords of memory and 10 Cray-2 hours. In support of the NASA Langley High-Speed Research (HSR) program, a different HSCT configuration was analyzed with CFL3D. This configuration was designed for supersonic cruise at Mach 2.4 and consisted of a cranked arrow wing with a 73 degree inboard leading-edge sweep and a 60 degree outboard sweep. The results from the analysis are shown in the accompanying figure. The color contours show total pressure and the lines on the surface are particle traces simulating flow near the body of the HSCT. The vortex-dominated flow field that is characteristic of these configurations at low speed is clearly shown. These results were compared with experimental data and are shown in the second figure. In addition to excellent force comparisons (the bottom portion of the figure), predicted flow-field characteristics very closely matched results obtained with laser-light sheet-flow visualization data from the wind tunnel.

## Significance

One of the challenges in the HSR program is improving the low-speed characteristics of configurations optimized for high-speed cruise—particularly the high-lift characteristics of the vehicles. Experimental and computational work is being done to understand and control the dominant flow physics. The computations demonstrate the ability of these methods to help solve the problems. An initial concern regarding the use of these codes was the convergence rate of the codes at low free-stream Mach numbers. In all cases, the convergence rate of the methods was acceptable.

## Future Plans

We plan to complete our analysis and comparison of the three codes on the Mach 3 configuration. A high-lift version of the Mach 2.4 configuration will be analyzed.



Total pressure contours from the CFL3D solution on the AST-210 configuration.

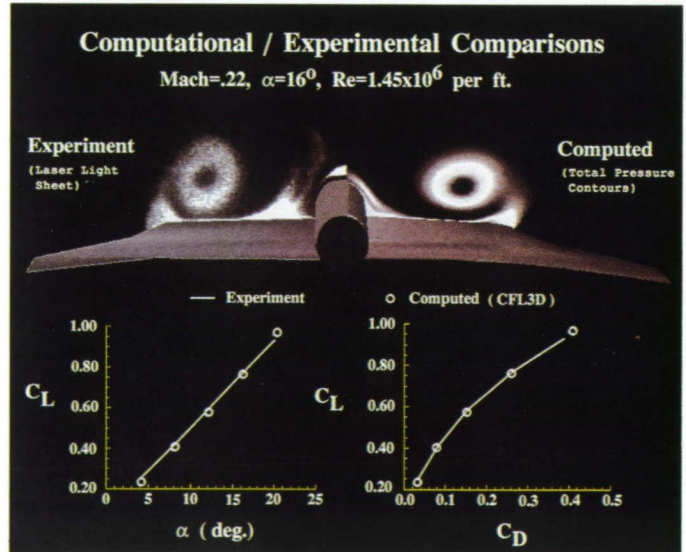

Comparison between CFL3D results and experimental data for the AST-210.

# Structure and Dynamics of Multidimensional Flames

K. Kailasanath, Principal Investigator  
Co-Investigator: G. Patnaik  
Naval Research Laboratory

## Research Objective

To develop a better understanding of the differences in the propagation and extinction of premixed flames in Earth's gravity and in microgravity.

## Approach

A detailed, time-dependent, multidimensional, multispecies, numerical model is used as a tool to simulate flames in different gravitational environments. The model includes finite-rate detailed chemical kinetics coupled with algorithms for convection, thermal conduction, viscosity, molecular diffusion, and external forces such as gravity.

## Accomplishment Description

The effects of gravity and heat loss have been systematically investigated in a series of simulations of hydrogen-air flames. These simulations show that both gravity and heat loss to the confining walls are simultaneously required to cause the

downward-propagation flammability limit observed on Earth. The calculated limit of 9.75% hydrogen in the air and the details of the extinguishment process are in excellent agreement with experimental results. A typical calculation takes 30 Cray Y-MP hours.

## Significance

This is the first multidimensional numerical simulation that has considered effects such as heat loss and gravity along with detailed chemical kinetics. The excellent agreement with the experimental results suggests that such simulations can now be used to more confidently predict the behavior of flames in reduced-gravity environments.

## Future Plans

The code will now be used to simulate and understand a number of interesting flame phenomena observed on Earth and in space.

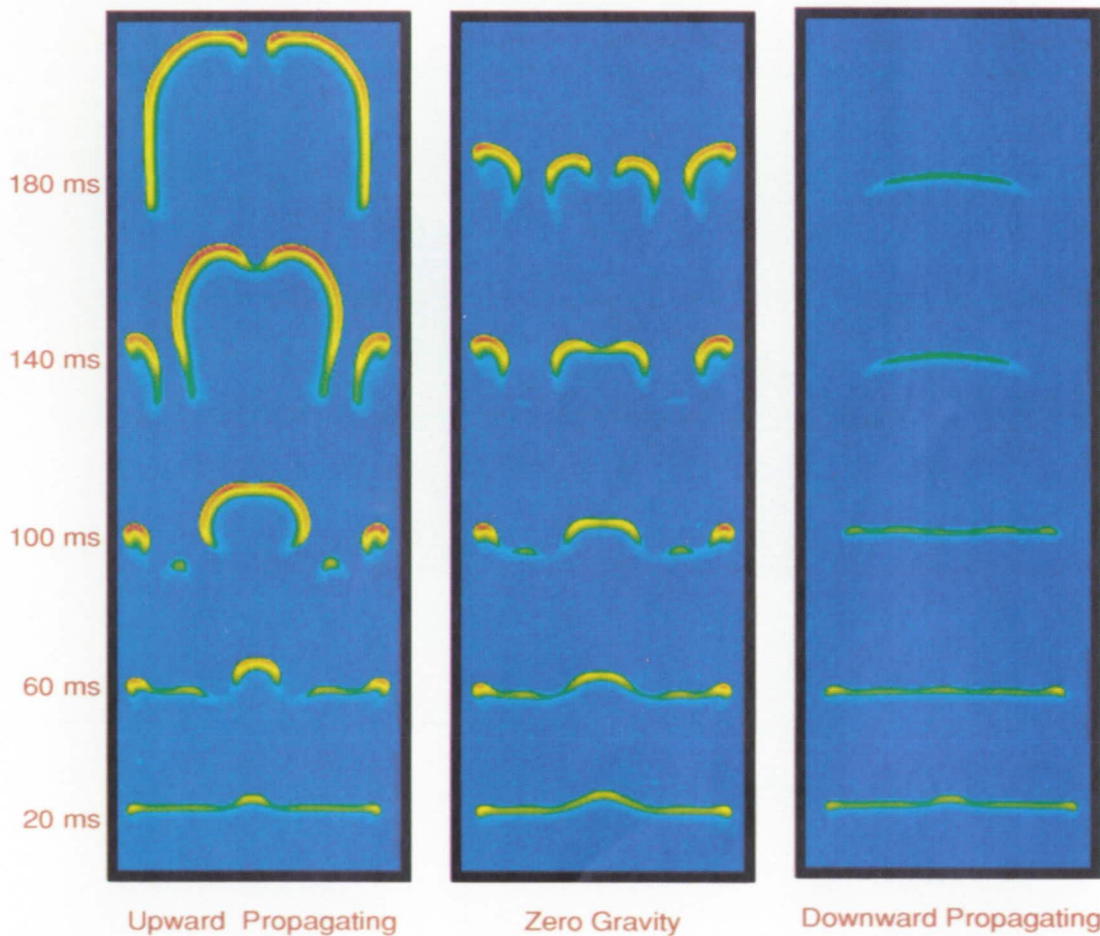

Comparison of upward- and downward-propagating flames to zero-gravity flames in a 10% hydrogen-air mixture.

# Unsteady Nozzle Flow Fields

K. Kailasanath, Principal Investigator  
Co-Investigator: R. Ramamurti  
Naval Research Laboratory

## Research Objective

To study the transient flow field in a nozzle and gain a better understanding of the nonlinear interactions between the shock waves generated in the start-up procedure and the nozzle geometry.

## Approach

The three-dimensional time-dependent conservation equations describing compressible flows in complex geometries are solved using unstructured grids and a finite-element flow solver. An adaptive refinement strategy in conjunction with an arbitrary Lagrangian–Eulerian form allows the tracking of complex shock-structures and moving objects in the flow field.

## Accomplishment Description

A series of simulations have been carried out to study the effects of initial conditions such as nozzle exit clearance and flow leakage through baffles on the transient flow in the nozzle. A configuration has been identified that avoids excessive pressure buildup in the nozzle and unwanted loads on the nozzle–motor

junctions. The accompanying figure shows a typical three-dimensional flow field in the nozzle at a particular time. A typical simulation takes 50 Cray Y-MP hours.

## Significance

These simulations have been crucial in understanding the unsteady start-up process in nozzles used for propulsion systems such as the Trident II. Furthermore, a capability now exists to simulate unsteady compressible flows in complex geometries with moving parts.

## Future Plans

No further simulations are planned. However, the code can now be used to simulate other problems involving transient compressible flows in complex geometries.

## Publication

Ramamurti, R.; Kailasanath, K.; and Lohner, R. "Numerical Simulation of Unsteady Flow in a Nozzle." *1992 JANNAF Propulsion Meeting*. Indianapolis, IN, Feb. 1992.

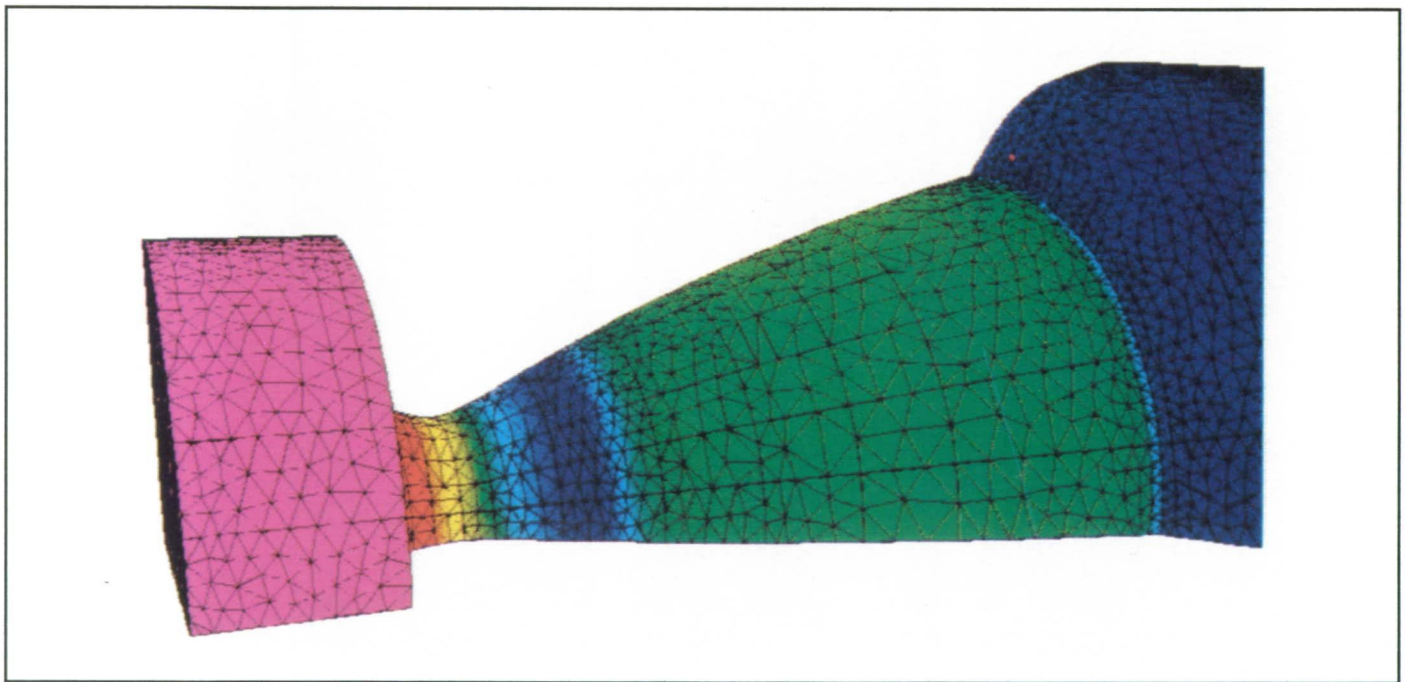

*Instantaneous pressure distribution in a nozzle from 0.7 atm (blue) to 8.7 atm (magenta).*

# Simulation and Control of Slender Wing Rock

Osama A. Kandil, Principal Investigator  
Co-Investigator: Ahmed A. Salman  
NASA Lewis Research Center/Old Dominion University

## Research Objective

To simulate the limit-cycle rock motion of slender delta wings and investigate active control of the rock motion using antisymmetric forced oscillation of the wing leading-edge flaps.

## Approach

The problem has three sets of equations. First, the unsteady compressible Euler equations are written relative to a moving frame of reference. Second, the unsteady linearized Navier-displacement equations are used in the moving frame of reference to compute the grid displacements whenever the leading-edge flaps oscillate. Third, are the Euler equations of rigid-body motion for the wing or for the wing and its flaps. This set computes the wing motion for the wing-rock problem and is solved in sequence with the first set. To control wing rock, the third set is solved in sequence with the first and second sets.

## Accomplishment Description

A delta wing with a sweep-back angle of 80 degrees at 35 degrees angle of attack and Mach 1.4 is considered. The

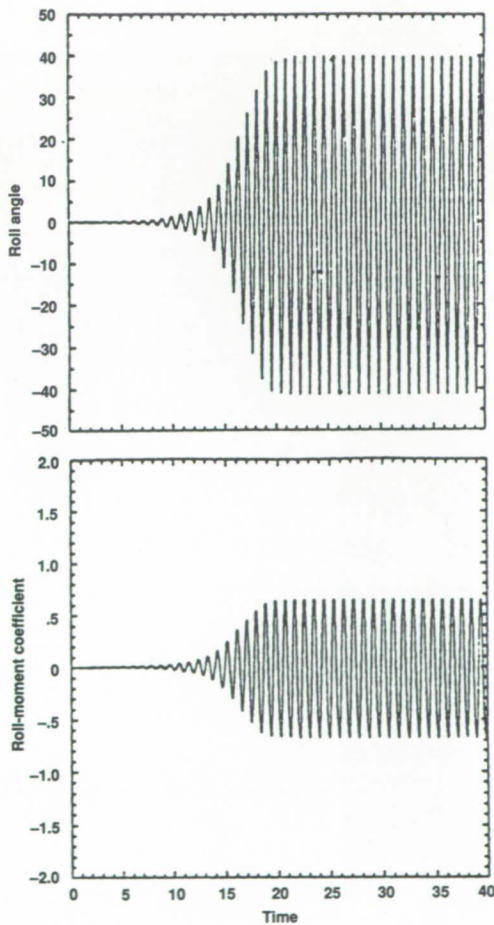

Roll-angle and roll-moment-coefficient responses for an unstable rolling motion (wing rock).

wing-mass moment of inertia about its  $x$  axis is 0.02, the bearing damping coefficient is 0.2, and the spring stiffness is 0.74. The unsteady Euler equations are solved for locally conical flows. For these flow conditions, the steady flow is asymmetric. The Euler equations of fluid flow and of rigid-body dynamics are sequentially integrated in time. The accompanying figure shows the results of this case. The time responses show the long time needed to build up the unstable response. The roll angle and roll-moment coefficient increase in time with an increase in frequency. The limit-cycle response is reached at  $t \approx 21$ . To control the wing-rock response, a leading-edge flap hinge is assumed to be at the 76% location of the local half-span length. Flap motion is antisymmetric. The equation for the wing-flap motion is sequentially integrated in time. The second figure shows the time responses for the wing.

## Significance

The codes treat multi-disciplinary problems where fluid-flow equations and rigid-body-dynamics equations interact.

## Future Plans

Aeroelastic equations have been added to the existing codes to solve for multidisciplinary problems where fluid-flow and aeroelastic equations interact. The vertical tail-buffet problem is being simulated.

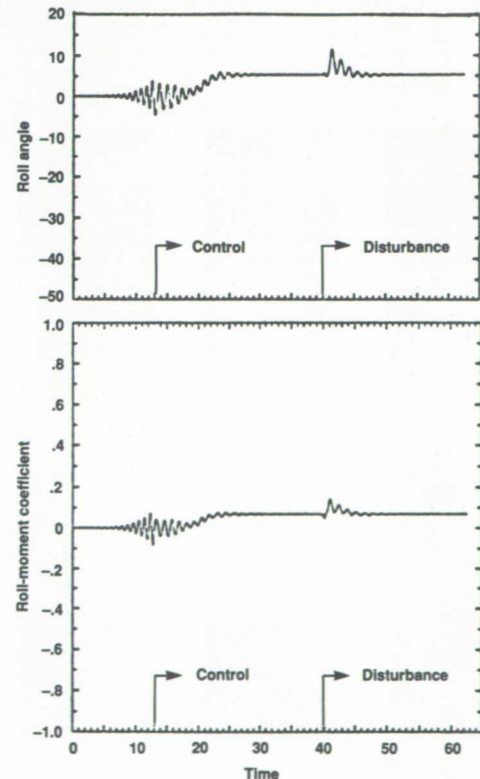

Active control of wing-rock motion using an anti-symmetric oscillation of the leading-edge flaps.

# Unsteady Ethylene Jet-Diffusion Flames

Carolyn R. Kaplan, Principal Investigator

Co-Investigators: Elaine S. Oran and Seung W. Baek

Naval Research Laboratory/Korea Advanced Institute of Science and Technology

## Research Objective

To examine the effect of radiation transport on the development, structure, and dynamics of an unsteady luminous ethylene jet-diffusion flame.

## Approach

The model solves the two-dimensional time-dependent Navier–Stokes equations with finite-rate chemical reaction, soot formation, and radiation transport models to simulate fluctuating axisymmetric ethylene–air jet-diffusion flames. The convection terms are solved using the barely implicit correction to flux-corrected transport algorithm. The radiative heat flux is found from a solution of the radiative-transfer equation using the discrete ordinates method. The soot formation and growth model is based on a set of coupled ordinary differential equations describing nucleation, surface growth, and coagulation. The effects of thermal conduction, molecular diffusion, and viscosity are included through explicit finite-differencing formulations.

## Accomplishment Description

The model is validated through comparisons with experimental data for a low-velocity laminar ethylene–air diffusion flame. Simulations conducted for the high-velocity (10 meters/second) fluctuating flame show that soot is the dominant absorbing–emitting medium and that radiation transport changes

the temperature, soot concentration, and chemical species distributions in the flame. Radiation transport reduces the maximum flame temperature by 140 K, reduces the width of the high-temperature and sooting regions in the flame, and causes the flame to accelerate slightly. The increase in the Reynolds number due to both lower viscosity and higher velocities results in more and stronger vortical structures in the inner jet shear layer. Results show the opacity of the flame is in the transitional regime between optically thin and optically thick, and heat transfer by radiation dominates opacity by conduction or convection. These computations require 6–10 megawords of memory and 10–20 Cray Y-MP hours.

## Significance

Although radiative properties of weakly radiating nonluminous diffusion flames can be calculated with reasonable accuracy using the laminar flamelet concept, prediction of strongly radiating luminous flames has remained a greater challenge. In this research, the effects and the interactions between the individual processes have been studied.

## Future Plans

The model will be extended to study stabilization mechanisms of ethylene jet-diffusion flames during the process of flame lift-off and reattachment to the burner.

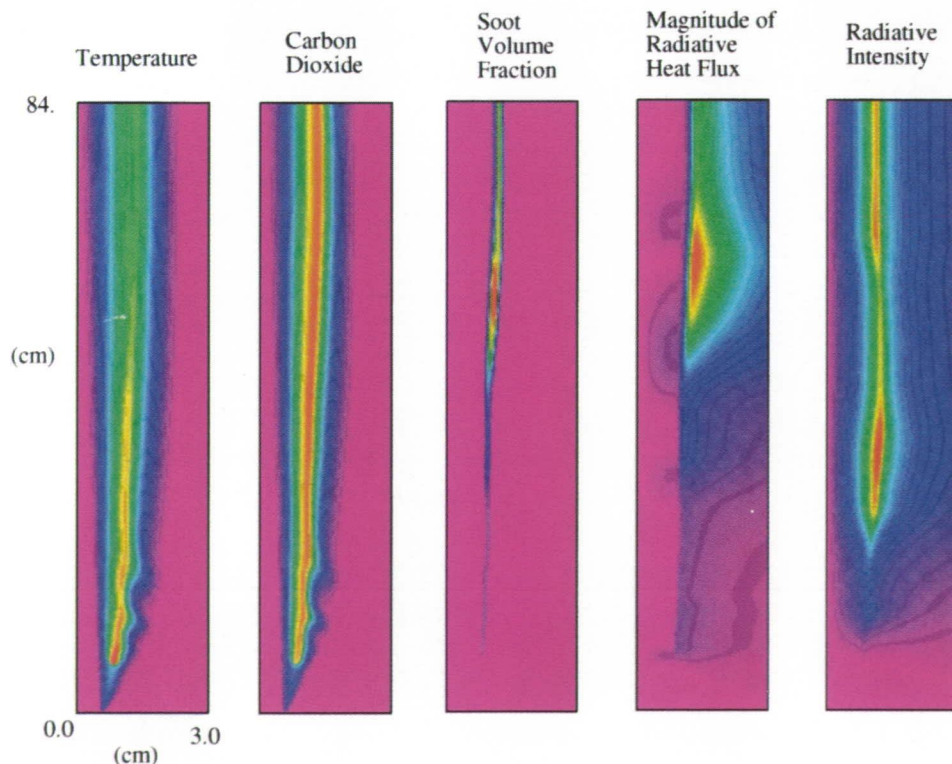

Contours of temperature, radiative intensity, and soot-volume fraction in a 3 cm × 34 cm region of an ethylene jet-diffusion flame.

# Unstructured Grid-Generation/Flow-Solver Calibration

Steve L. Karman, Jr., Principal Investigator  
Co-Investigator: Gregory S. Spragle  
General Dynamics, Fort Worth Division

## Research Objective

To demonstrate the capability to numerically model three-dimensional steady-state and time-dependent multi-body flow fields using state of the art unstructured-grid methods.

## Approach

Unstructured grid generation codes are used to discretize complex two- and three-dimensional configurations. Unstructured-grid flow solvers then compute time-dependent Euler/Navier-Stokes equations on the initial mesh or use grid refinement and adaption to enhance the mesh to improve solution accuracy and/or track moving boundaries within the mesh.

## Accomplishment Description

A robust two-dimensional unstructured-grid generation code has been developed for triangular meshes with arbitrary geometries. A two-dimensional axisymmetric Navier-Stokes code with a two-equation turbulence model has been developed and calibrated on several two-dimensional and axisymmetric test cases. An initial three-dimensional unstructured-grid generation code has been developed and has successfully generated tetrahedral meshes for selected simple test cases. A three-dimensional Navier-Stokes code with a two-equation turbulence model has been developed and tested on simple geometries using tetrahedral grids created from structured three-dimensional grids. Calibration of the three-dimensional flow solver has been limited due to the inability to generate a three-dimensional unstructured mesh. Further calibration work has been done on the turbulence model for two-dimensional geometries. The first case was a high-speed inlet flow field and the second case was a multiple-slot ejector flow field. Comparisons with experimental data and other computational fluid dynamics codes were made. An alternative approach to analyzing complex geometries involves the use of Cartesian grids generated by recursively subdividing a root cell that encompasses the entire domain. Results from initial two-dimensional work shows promise of overcoming many of the grid generation problems encountered with the traditional unstructured triangular and tetrahedral schemes. Extension of the method to three dimensions should be relatively easy.

## Significance

The development of this unstructured-grid capability is significant in the evaluation of store separation from aircraft and complex problems such as inlet unstart.

## Future Plans

The calibration of the Cartesian-based unstructured-grid method in two dimensions will continue. The development of the three-dimensional code will begin. Once the three-dimensional capability becomes available, the code will be tested on various complex geometries and flow fields.

## Publications

1. Karman, S. L., Jr. and Spragle, G. S. "Development of an Unstructured CFD Method." AIAA Paper 91-0019, Jan. 1991.
2. Karman, S. L., Jr. "Development of a 3D Unstructured CFD Method." Dissertation, University of Texas at Arlington, May 1991.
3. Karman, S. L., Jr. and Spragle, G. S. "Calibration of 2D Unstructured Grid Methods on Propulsive Flow Fields." AGARD FDP Symposium, Aerodynamic Engine-Airframe Integration, Fort Worth, TX, Oct. 1991.

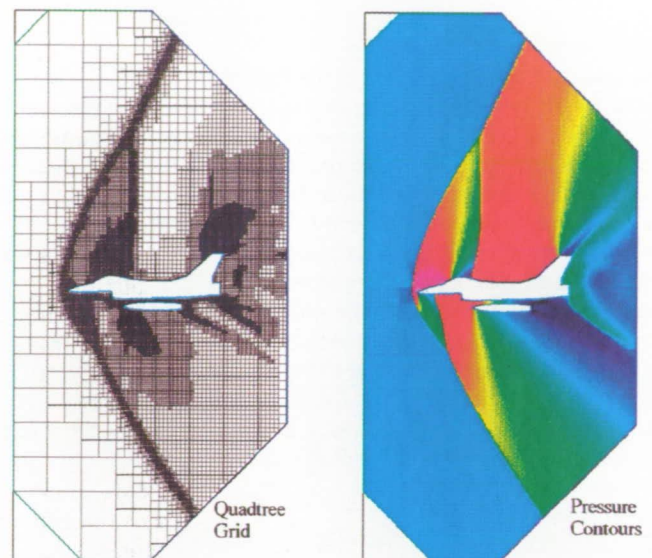

*Aircraft store grid and flow field.*

# Turbulent Flow over Riblet-Mounted Surfaces

George E. Karniadakis, Principal Investigator  
Princeton University

## Research Objective

To quantify the drag reduction caused by riblets and to understand the responsible physical mechanism.

## Approach

The incompressible Navier–Stokes equations are discretized in space using a mixed spectral-element Fourier method and in time using a high-order splitting method. The computational domain is a channel with a lower wall mounted with streamwise riblets and a smooth upper wall. A typical run requires 3–5 Cray Y-MP seconds and approximately 20 megawords of memory per time-step.

## Accomplishment Description

Simulations were performed in the Reynolds-number range 500–5,000, corresponding to laminar, transition, and turbulent regimes. The effect of riblet geometry was also investigated as a means of finding an optimum drag-reduction design; V-grooves (triangular), curved, and shark-scale-like (dermal dendrite) riblets were tested. Results suggest that in the laminar regime there is no drag reduction, but in the transitional and turbulent regimes drag reduction of up to 6% exists for the V-groove riblet-mounted wall compared to the smooth wall. A detailed study of turbulence structure was conducted for triangular riblets. All turbulence statistics including turbulence intensities, Reynolds shear stresses, skewness, and flatness factors were accurately computed. Based on our results, a physical model for the drag-reducing mechanism was devised.

## Significance

This computation is the first direct numerical simulation of turbulence in a complex geometry domain and demonstrates the flexibility of the hybrid spectral-element Fourier method in efficiently simulating such flows. Riblets are used for civil transport airplanes and result in significant savings. Therefore, the accurate prediction of such flows is very important.

## Future Plans

Simulations at higher Reynolds numbers for the optimal riblet geometry—the shark-like riblets—will be addressed. A large-eddy-simulation approach based on renormalization group-subgrid models will be followed.

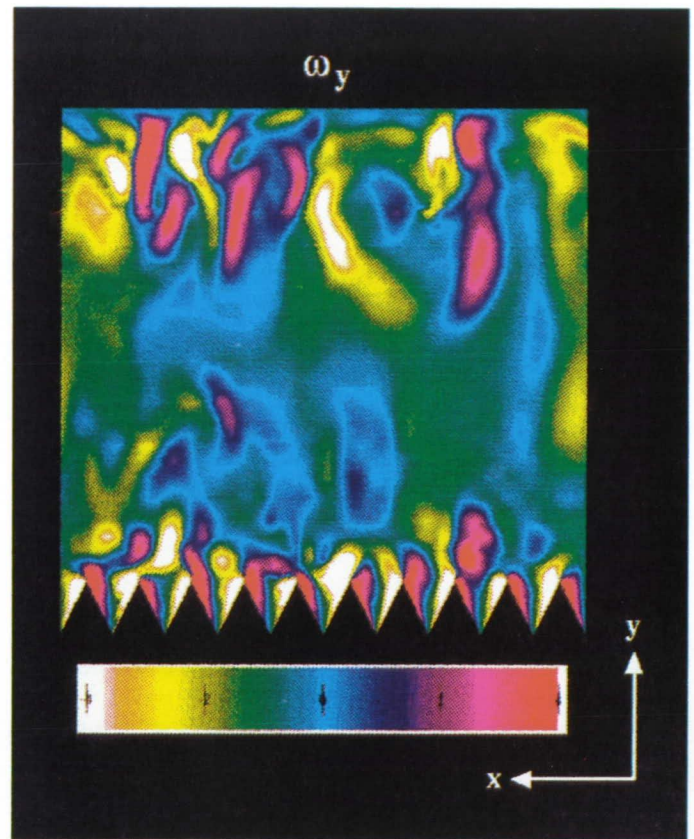

*Instantaneous streamwise vorticity contours (vertical component) on a plane perpendicular to the flow. Red represents positive values and white represents negative values.*

# Turbulent Flow over a Backward-Facing Step

G. E. Karniadakis, Principal Investigator  
Co-Investigator: S. A. Orszag  
Princeton University

## Research Objective

To test the subgrid model obtained with the renormalization group theory (RNG), especially in the early turbulence regime, and to investigate the flow physics in transitional and fully turbulent states.

## Approach

The incompressible Navier–Stokes equations are integrated using the spectral element method and a subgrid model derived by the RNG of turbulence. Approximately 1 million degrees of freedom were employed in the computation, requiring 20 megawords of memory and 3 Cray Y-MP seconds per time step.

## Accomplishment Description

Following our earlier work on equilibria and transition in flow over a backward-facing step, a numerical study of turbulent flow up to Reynolds number 9,000 was conducted. The size of the separation zone is a decreasing function of the Reynolds number in the transition regime and is constant in the fully turbulent

regime. We performed simulations at three Reynolds numbers (2,500, 4,000, and 9,000) corresponding to early transition, late transition, and fully turbulent regimes, respectively. Our simulation results agree with the experimental results and predict the variation of the separation length in the transition regime.

## Significance

The flow over a backward-facing step represents a prototype for many internal flows where sudden expansions cause massive separation. It also serves as a good test case for both discretization and subgrid models for turbulent separated flows.

## Future Plans

Future work will address the robustness of the RNG subgrid model with respect to discretization variations and will extend the simulation to Reynolds number 20,000. A companion experiment being performed at NASA Langley will provide detailed data for mean flow quantities and turbulence statistics.

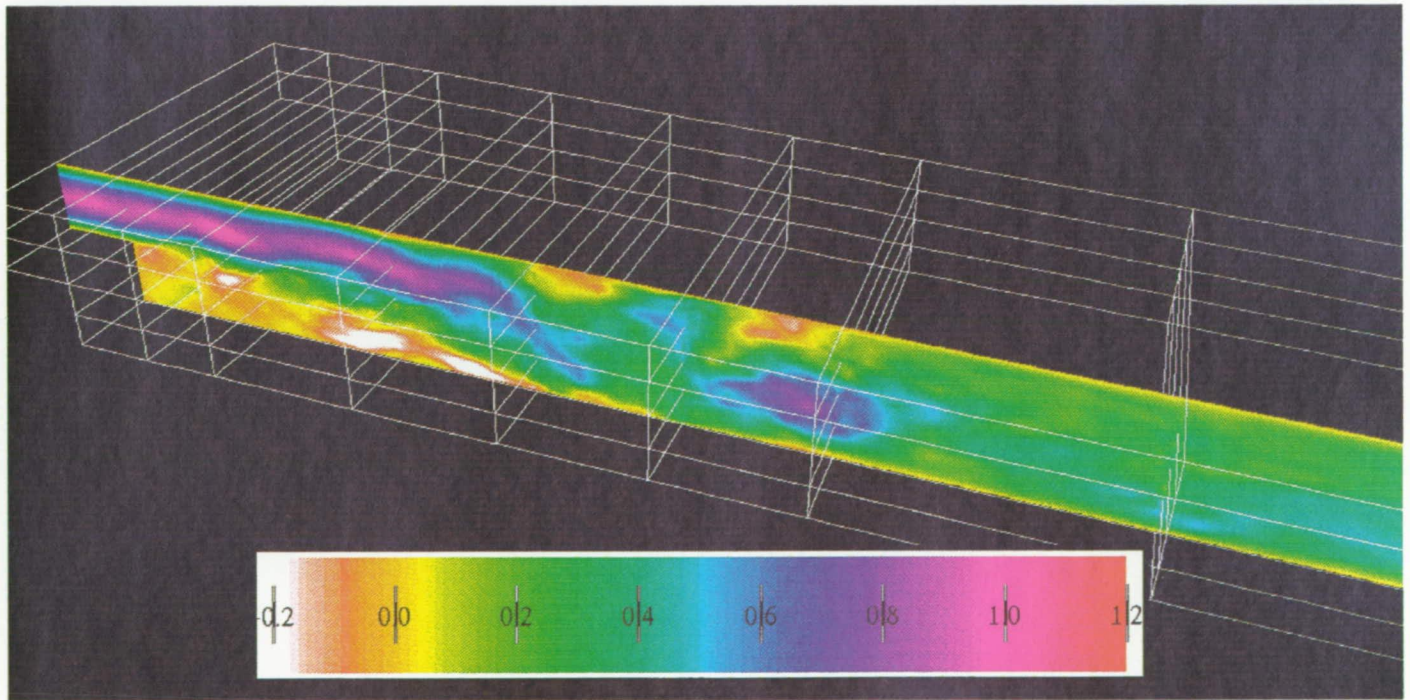

*Instantaneous streamwise velocity contours in a flow over a backward-facing step at Reynolds number 9,000. Red represents positive values and white represents negative values (separated flow).*

# Aeronautical Vehicle Radar Cross Sections

Jack H. Kennedy, Principal Investigator  
Co-Investigator: Daniel A. White  
General Dynamics, Convair Division

## Research Objective

To develop advanced computational radar cross-section (RCS) analysis techniques to design the next generation of high-stealth cruise missiles.

## Approach

The work is centered around two electromagnetic scattering codes, the representation theorem method (RTM) and the finite-element radiation model (FERM). RTM is a two-dimensional code that models linear dielectric and magnetic materials used in modern aeronautical systems. FERM is a three-dimensional code primarily used to analyze scattering from conductive bodies. Both codes are computationally intensive for even moderate-sized bodies. Work with RTM is concentrating on developing a capability to optimize geometry and material parameters for minimum RCS. FERM is being used to display induced surface currents on targets in order to model the special currents created by interactions between edges and interfaces on aeronautical vehicles.

## Accomplishment Description

We validated RTM predictions for radar absorbing materials (RAM) with significant magnetic characteristics (large permeabilities). RAM-coated flat plates were constructed and the scattering response was measured for comparison with RTM predictions. Work was also done on validating the FERM code. Two fins of the type used on the Tomahawk cruise missile were modeled

using the code. RCS measurements were carried out over a range of 3–10 GHz at both horizontal and vertical polarizations for 360 degree orientations of the targets. Predictions were generated and are currently being evaluated. A capability was also developed for extracting and displaying surface currents predicted in the code. In the accompanying figure the target segmentation and the results of current predictions for one of the fins analyzed are shown. Relative current amplitudes and directions are shown as short line segments over the surface of the fin. These results typically require about 1.5 Cray-2 hours and 20 megawords of memory.

## Significance

Developing high-stealth aeronautical vehicles is a top priority of the United States military. As requirements increase, empirical design approaches have proved costly and are limited in their effectiveness. New analytic methods are required to speed the design effort and to find better designs.

## Future Plans

After completing validation studies of the RTM and FERM codes, prediction capabilities will be improved. Improvements in RTM algorithms are under development. Studies of RTM and FERM target segmentation will be carried out to determine which type of segmentation produces the most accurate predictions for different target shapes, sizes, and radar frequencies.

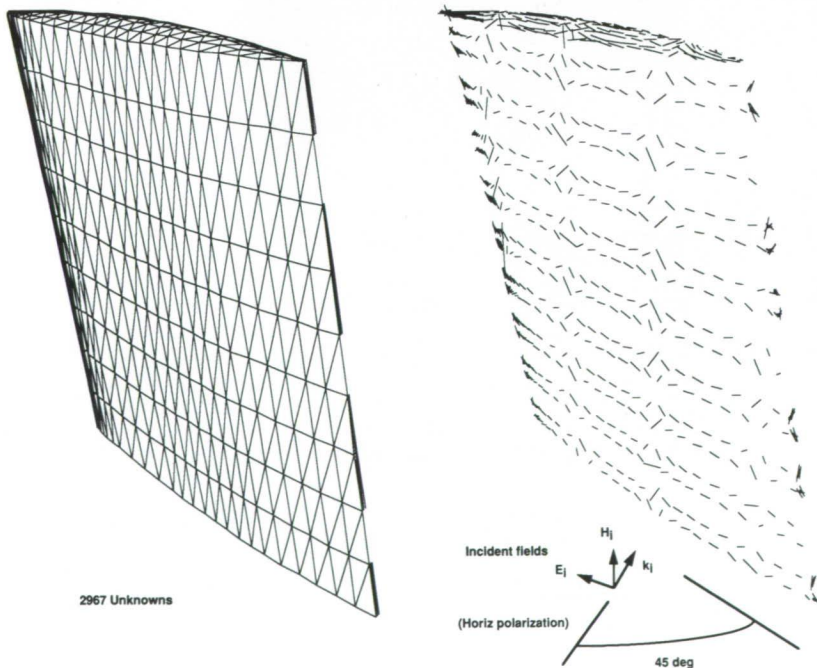

*Cruise-missile fin segmented for analysis of the finite-element radiation-model code and the currents predicted for oblique field incidence.*

# Orographically Forced Oscillations of the Martian Atmosphere

Christian L. Keppenne, Principal Investigator  
Co-Investigator: Jean O. Dickey  
Jet Propulsion Laboratory

## Research Objective

Low-frequency oscillations caused by barotropic instability over orography cause significant variations of the length of day on Mars. Since the surface relief irregularities of Earth and Mars are similar in their scale heights, orographically forced modes effecting the Martian rate of rotation should also be expected.

## Approach

A barotropic dynamical model in spherical coordinates with realistic topography is run at high resolution in several 6,000-sol (Martian day) integrations (see the accompanying figure). The model is based on the primitive-equation system used in operational general-circulation models, but it is formulated without accounting for thermodynamic processes such as the cycles of water on Earth or carbon dioxide on Mars. As a result, barotropic instability over orography is the main cause of variability. The atmospheric angular momentum (AAM) of the last 5,000 sols of each run is spectrally analyzed. Composite maps of the free-surface height-anomaly fields are keyed to a filtered AAM time series to analyze the spatial details associated with the oscillations detected in the global AAM time series.

## Accomplishment Description

The code is multitasked and the prognostic equations are integrated in spectral spherical harmonic space, using a semi-implicit scheme, but the nonlinear terms are computed on a latitude-longitude grid. At high-resolution ( $192 \times 150$  gridpoints), performance comes close to 1 GFLOP using all eight processors. At a more modest resolution, performance decreases to 500 MFLOPS or 0.2 Cray Y-MP second per sol and about 8 megawords of memory. Two robust oscillations with periods near 85 and 125 sols were identified in the model AAM time series. They persist over a significant range of model parameters or when seasonal variations are introduced in the forcing. The corresponding spatial variability shows standing oscillations with centers of action upstream and downstream from the highest Martian mountains (see the accompanying figures).

## Significance

Because the total AAM of the Mars atmosphere system is conserved, it produces variations in the Martian day length on the order of tens of milliseconds. Predicting such changes is important for space navigation and will be beneficial to future space missions.

## Future Plans

Interference between the observed oscillations and comparatively shorter timescale phenomena will be examined. This will require a model with higher vertical resolution and the appropriate parameterization of some processes neglected in this study.

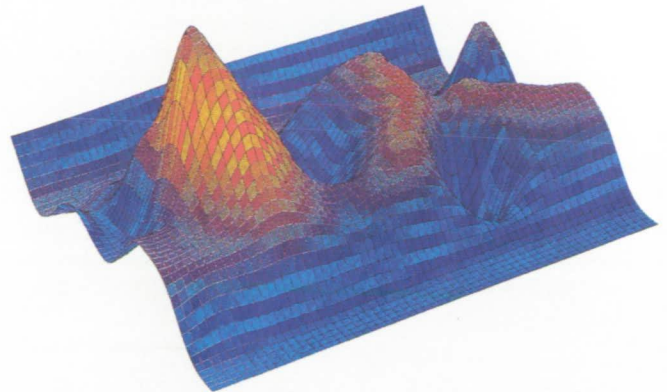

*Barotropic dynamical-model topography projected onto a rectangular grid.*

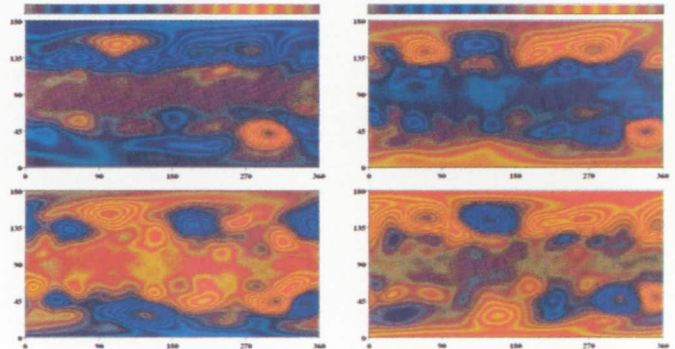

*Composites of a free-surface height anomaly showing the four phases of the (a) 85-sol oscillation and (b) 125-sol oscillation. The composites are keyed to the maxima and minima of a filtered atmospheric angular momentum time series and its first derivative.*

# Low-Thrust Chemical Rockets

Suk C. Kim, Principal Investigator  
Sverdrup Technology, Inc./NASA Lewis Research Center

## Research Objective

To study the flow fields and performance of low-thrust space propulsion rockets.

## Approach

A full Navier–Stokes code with a finite-rate chemistry code (RPLUS) is used to calculate the flow fields and performance of low-thrust chemical rocket nozzles. The combustion processes of hydrogen and oxygen are modeled by an 8-species, 18-step reaction mechanism and are compared with experimental data.

## Accomplishment Description

Calculations were made for the 25 lb<sub>f</sub> gaseous hydrogen–oxygen thruster designed for Space Station Freedom, which uses film-cooling hydrogen injection to cool the thruster wall. The results for various mixture ratios and fuel film-cooling percentages show that the vacuum-specific impulse decreases by increasing the

mixture ratio and film-cooling percentages and agrees well with the experimental data. A typical run requires approximately 4 megawords of memory and 11 Cray Y-MP hours.

## Significance

The study demonstrates that the full Navier–Stokes code with a finite-rate chemistry can be used for performance prediction of various chemical rockets.

## Future Plans

The flow fields and performance of various space propulsion rockets will be studied.

## Publication

Kim, S. C. and VanOverbeke, T. J. "Performance and Flow Calculations for a Gaseous Hydrogen/Oxygen Thruster." *J. Spacecraft and Rockets* 28, no. 4 (1991): 433–438.

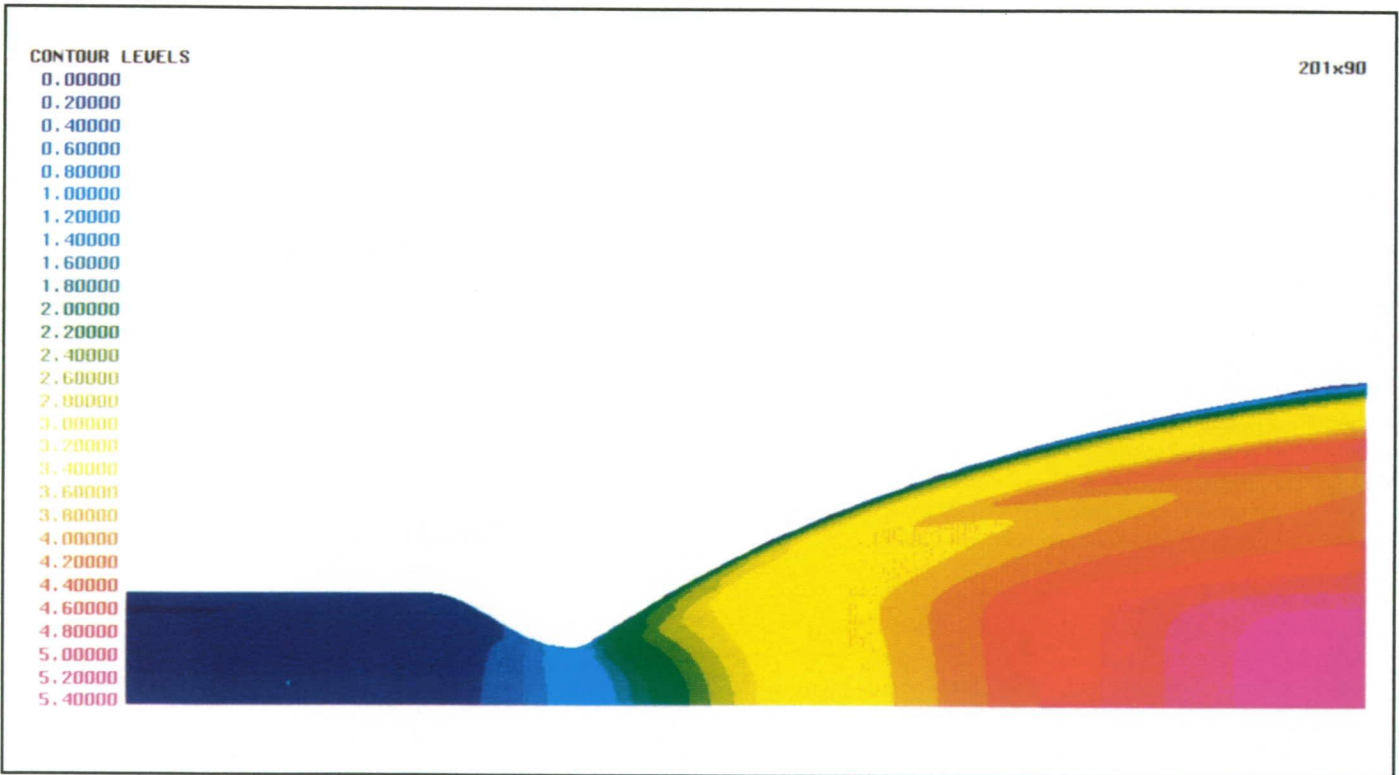

*Mach number contours; mixture ratios = 3.12, fuel film-cooling = 85.5%.*

# Fluid Flow of Jets in Cross Flow

S. W. Kim, Principal Investigator  
Co-Investigator: T. J. Benson  
NASA Lewis Research Center

## Research Objective

To develop and validate a numerical analysis method to investigate the large-eddy mixing phenomenon occurring in separated and recirculating fluid flows of jets in cross flows.

## Approach

The Reynolds-averaged Navier–Stokes equations are solved using a finite-volume method that incorporates a partial differential equation for incremental pressure to obtain a divergence-free flow field. The turbulence is described by a multiple-time-scale turbulence model.

## Accomplishment Description

Numerical results show that large-eddy mixing occurs in the wide region along the jet edge and that fluid particles in the center region of the jet do not easily mix with the cross flow. The multiple-time-scale turbulence equations successfully predict the horseshoe vortex located in the forward region of the jet while several numerical investigations using  $k$ - $\epsilon$  turbulence models and Reynolds stress-turbulence models fail to predict the horseshoe vortex. The calculated fluid flow and the concentration field show that the local maximum concentration occurs where there is minimum velocity along the jet. This trend is in excellent

agreement with the measured data. The accurate numerical results obtained in the present investigation are attributed to the capability of the multiple-time-scale turbulence equations to resolve the nonequilibrium turbulence phenomena. Calculation of the fluid flow with 0.8 million grid points and 7.3 million degrees of freedom requires 60 megawords of memory and 20 Cray Y-MP hours.

## Significance

Turbulent flows similar to jets in cross flows can be found in a number of engineering applications. For example, in gas turbine combustors, a number of circumferentially distributed jets are used to ensure correct combustion and to dilute the hot gas entering the turbine. The accurate numerical results help to understand the large-eddy mixing and the turbulent transport of heat and mass in jets in cross flows. The capability to accurately solve complex fluid flows is useful for design and analysis of advanced fluid machinery.

## Future Plans

Numerical investigations of heat transfer and topological analysis of separation and reattachment locations for jets in cross flows will be done.

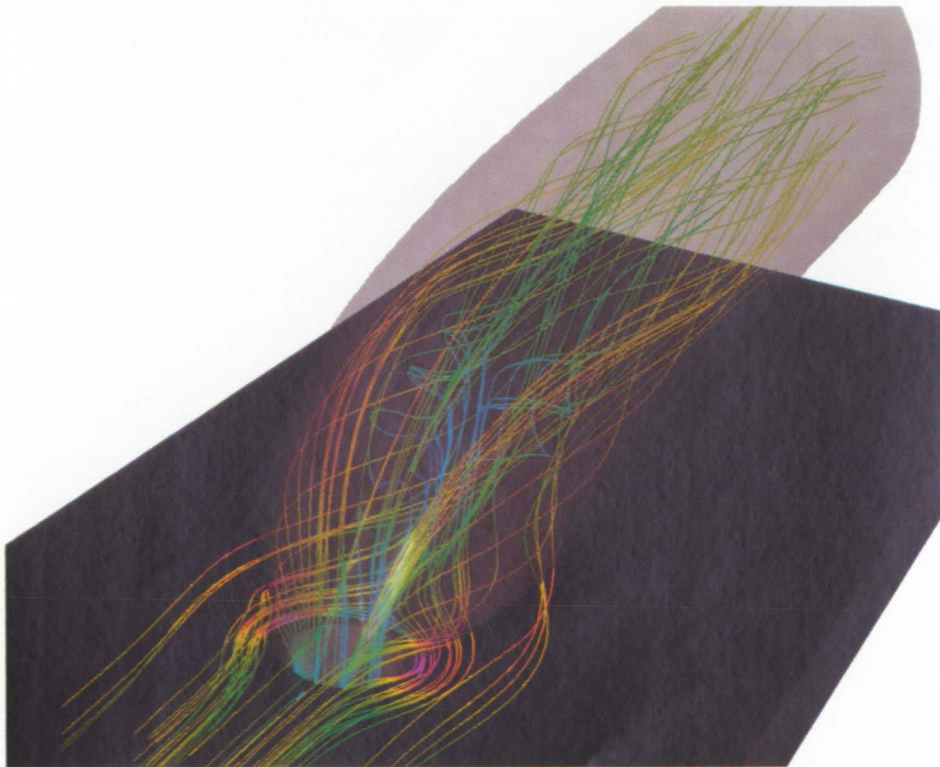

*The computed flow field for an incompressible fluid injected into a cross flow with a 2:1 velocity ratio. The penetration of the jet is shown by the light gray cloud being swept downstream while the colored particle traces show the three-dimensional interaction of the streams.*

# Multistage Turbomachinery Flows

Kevin R. Kirtley, Principal Investigator

Co-Investigators: John J. Adamczyk, Tim A. Beach, Mark L. Celestina, William A. Maul, and Rick A. Mulac  
Sverdrup Technology, Inc./NASA Lewis Research Center

## Research Objective

To more fully understand the development of secondary flows and their impact on mixing and performance in multistage turbomachinery flows.

## Approach

The average-passage Navier–Stokes equations accurately describe the time mean flow in each blade-row embedded in a multistage environment. Therefore, these equations are solved using an explicit Runge–Kutta time-integration scheme with a multigrid for analysis of axial, radial, and mixed-flow compressor and turbine stages.

## Accomplishment Description

The two-stage Pratt & Whitney space shuttle main engine fuel-turbopump turbine was simulated using experimental test-rig conditions. Previous simulations using design conditions were validated by a good comparison with the data at the cold-flow test-rig condition. The two-stage turbine simulation required 21 megawords of memory and 40 Cray Y-MP hours. Two transonic mixed-flow turbine-stage builds were also simulated. The results matched experimental data quite well. The simulations were used to study development and migration of secondary flows in mixed-flow machines, identify potential loss mechanisms, and guide future redesign efforts. The single-stage simulations required 16 megawords of memory and 11 Cray Y-MP hours.

## Significance

The average-passage Navier–Stokes equations are efficient and useful tools for studying the development and impact of secondary flows and the effect of deterministic unsteadiness on the time mean flow in multistage turbomachinery. The results can be used to improve performance.

## Future Plans

Improved numerical and mesh-generation algorithms and average-passage stress modeling will be developed. In particular, a diagonalized lower–upper multigrid technique is being developed for multiblock mesh topologies for more accurate simulations of turbomachinery with splitter blades, part-span shrouds, and tip-clearance gaps.

## Publications

1. Kirtley, K. R. and Beach, T. A. "Deterministic Blade-Row Interactions in a Centrifugal Compressor Stage." ASME Paper 91-GT-273, 1991.
2. Kirtley, K. R.; Beach, T. A.; and Rogo, C. "Aeroloads and Secondary Flows in a Transonic Mixed-Flow Turbine Stage." Presented at the 37th International Gas Turbine Conference, June 1992.

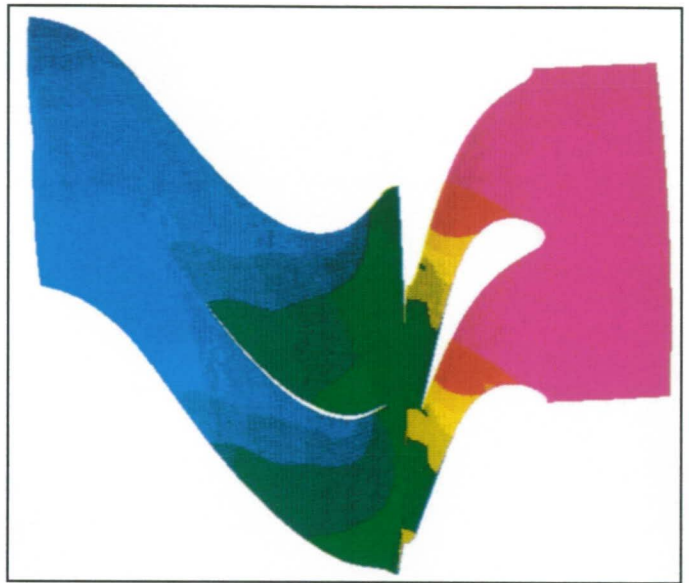

*Hub static pressure for a single-stage mixed-flow turbine.*

# Turbulent Boundary Layers with Suction

W. Kollmann, Principal Investigator  
 Co-Investigator: P. Mariani  
 University of California, Davis

## Research Objective

To simulate turbulent boundary layers with suction and statistically evaluate the boundary-layer structure in Eulerian and Lagrangean frames. The investigation of the structural properties is based on iso-surfaces for fluctuating scalar variables and the statistical quantities relevant for second-order closures are to be determined.

## Approach

The direct simulation of the boundary-layer flows is carried out with the spectral method developed by Spalart at NASA Ames using Fourier modes for the directions parallel to the wall and Jacobi polynomials for direction normal to the wall. The suction, or blowing, velocity is included as a single mode. The structural analysis is based on triangularized iso-surfaces allowing the calculation of topological and geometrical properties as a function of the level values. The statistical analysis is based on averaging in time, horizontal planes, and averaging over material points tracked during the simulation.

## Accomplishment Description

The direct simulation of a flat-plate boundary layer with zero pressure gradient and a suction velocity  $v_o/u_\infty = 0.0038$  (corresponding to an available set of measurements) and a Reynolds number of 500, based on the displacement thickness, was

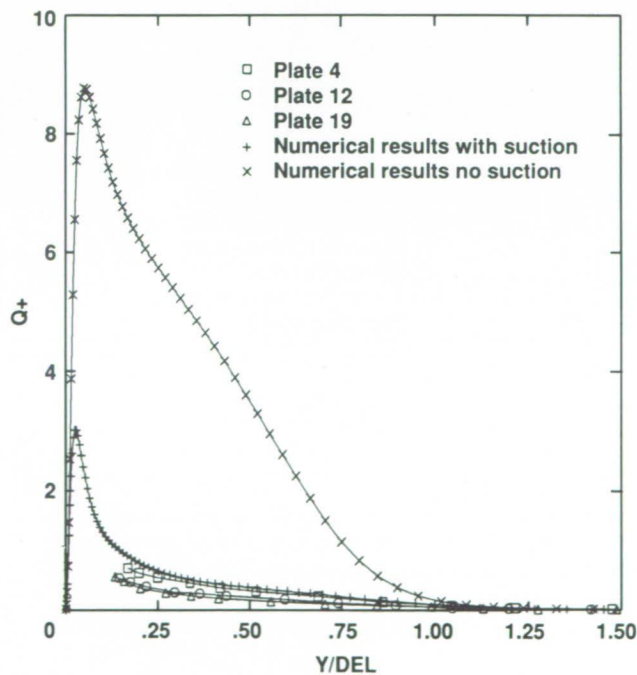

The kinetic energy of turbulence for the boundary layer.

completed. The statistical analysis of the resulting flow was carried out and all quantities for the budget of the Reynolds stress components and the dissipation rate were determined. Evaluation of the results shows good agreement with the experiment. Comparison with the Spalart results for the boundary layer without suction shows significant modification of the flow structure in the inner layer. The simulation of the boundary layer with a Reynolds number of 1000 was also finished and the statistical evaluation completed. The first simulation (Reynolds number = 500) required 2 megawords of memory and 50 Cray-2 hours.

## Significance

The understanding of the relation between mass transport through the wall and the turbulence structure of the boundary layer should be improved considerably. The development of closure models for the prediction of turbulent boundary layers with transpiration should be aided by the statistical evaluation of the simulation results.

## Future Plans

The project objectives were achieved and evaluation of the results is near completion.

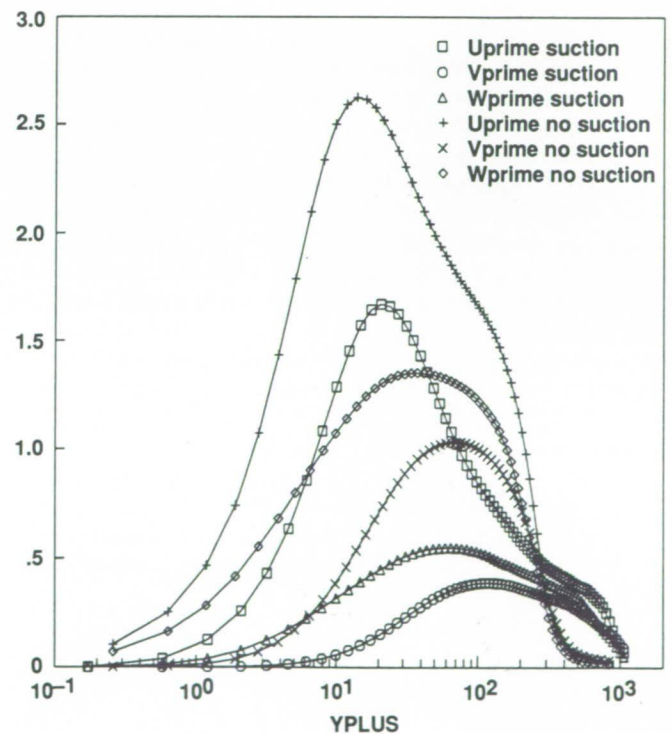

The effect of suction on normal stress components with suction are experimental (with suction, Watts and Brundrett, 1979; without suction, Spalart, 1988).

# Receptivity, Transition, and Turbulence Phenomena

Linda D. Kral, Principal Investigator

Co-Investigators: William W. Bower and Alexander Pal

McDonnell Douglas Research Laboratories

## Research Objective

To investigate the physical processes in fluids by simulating transition mechanisms or turbulence phenomena occurring in flows ranging from incompressible to supersonic speeds.

## Approach

Three areas of research are studied: boundary-layer transition, shear-layer dynamics, and boundary-layer receptivity. In the first two areas, direct numerical simulations (DNS) of the Navier–Stokes equations are performed, and in the third area, linearized Navier–Stokes equations are recast in spectral form and solved.

## Accomplishment Description

A parametric study of boundary-layer receptivity was performed to consider the excitation of Tollmien–Schlichting waves in a laminar boundary layer by a downstream-traveling plane sound-wave interacting with the flow through a porous strip which links the layer to a fluid-filled cavity acting as a receptivity site. By varying the Reynolds number for the fixed-strip width, it was found that the receptivity coefficient decreases with increasing Reynolds numbers. Resonance occurs when the ratio of cavity length to acoustic wavelength is 0.25. By varying the frequency of the sound wave for a range of strip widths normalized by the Tollmien–Schlichting wavelength, resonance again occurs (with maximal values of the receptivity coefficient) for the ratio of cavity length to acoustic wavelength equal to 0.25. The evolution of two-dimensional spatially evolving disturbances in a heated-water boundary layer was simulated. Previous investigations showed discrepancies between the direct simulations and stability theory for a heated boundary layer. A comparison between DNS, theory, and experiment is shown in the accompanying figure. Amplification rates are shown for several levels of heating. Comparison of the Navier–Stokes solution with parallel theory shows excellent agreement. Amplification rates are shown in the figure at several frequencies for  $\Delta T = 3.48^\circ\text{F}$ . The simulation results are in good agreement with both parallel and nonparallel theory and follow the experimental trends.

## Significance

Understanding boundary-layer transition and receptivity is crucial in the design of aerodynamic vehicles. Through investigations of the flow physics, the influence of transition and turbulence on skin friction, mixing enhancement, and separation can be predicted and controlled.

## Future Plans

We are investigating the physics of the compressible, boundary-layer transition process. An algorithm is being developed to perform DNS of compressible flows, including curvature effects, during the nonlinear stages of transition. Analysis of wall compliance on boundary layer receptivity to free-stream disturbances is being conducted.

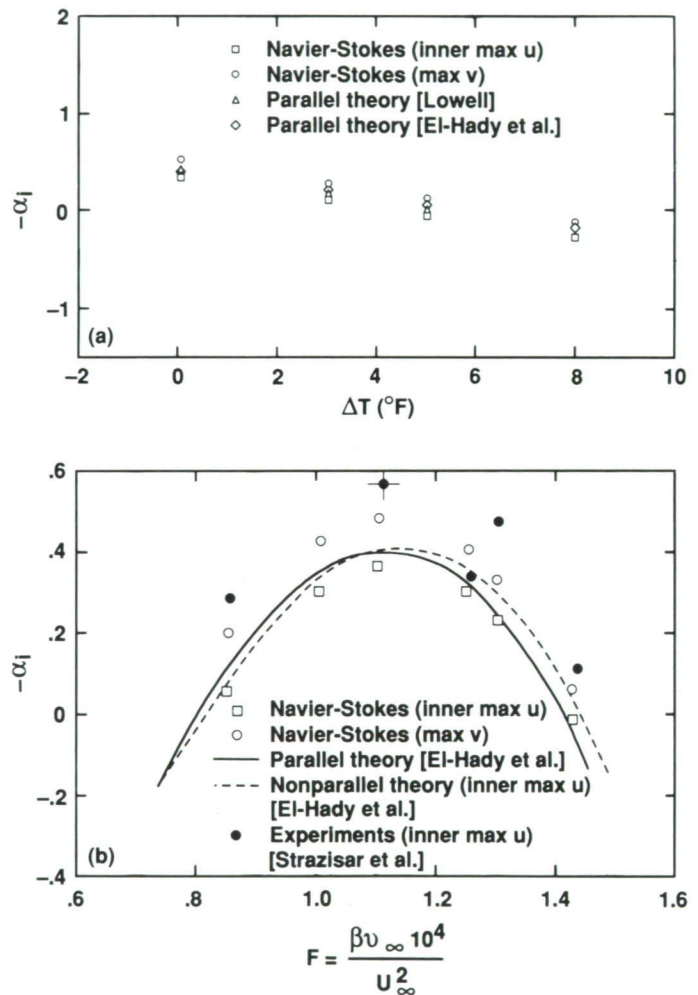

Comparison of amplification rates from direct numerical simulations with linear stability theory and experiments for different levels of wall heating at (a)  $F = 1$  and (b) different frequencies for  $\Delta T = 3.48^\circ\text{F}$ .

# Turbulence Modeling for Three-Dimensional Flow Fields

Linda D. Kral, Principal Investigator

Co-Investigator: John A. Ladd

McDonnell Douglas Research Laboratories/McDonnell Aircraft Company

## Research Objective

To investigate turbulence models used in numerical simulations of complex viscous flows for critical aircraft components.

## Approach

A three-dimensional zonal Navier–Stokes code with a two-equation turbulence model is used to predict the turbulent flow fields around flight vehicles. An implicit approximately factored upwind scheme is employed to solve the three-dimensional compressible Favre-averaged Navier–Stokes and energy equations together with the  $k$ - $\epsilon$  two-equation turbulence model. Three zero-equation algebraic models are also available in the code. Four low-Reynolds-number forms of the  $k$ - $\epsilon$  turbulence model are available.

## Accomplishment Description

Comparison of the  $k$ - $\epsilon$  model is made with the algebraic models for complex turbulent flows. Validation of the low-Reynolds-number models has been made for several turbulent flat-plate boundary layers (Mach = 0.3, 2.0, 3.0, and 4.5). The behavior in the near-wall region is best predicted by the Jones–Launder and Speziale low-Reynolds-number models. A calculation of a multi-slot ejector nozzle shows that the Jones–Launder  $k$ - $\epsilon$  model is better able to predict flow characteristics than the Thomas algebraic model. Mach contours for a nozzle pressure ratio of 14 and secondary total-pressure ratio  $P_{T_s}/P_{T_p} = 0.175$  are shown in the accompanying figure for the  $k$ - $\epsilon$  and algebraic model. Dark blue contours represent Mach 0.1 and magenta contours represent Mach 2.2. The interior static surface pressure and test data were compared. The algebraic model falsely predicts a large separated region at the last ejector slot, but the  $k$ - $\epsilon$  calculation does not show this tendency and agrees well with the test data. An investigation of a two-stream hypersonic mixing layer with finite-rate chemistry was conducted with the two-equation turbulence model and the Thomas shear-layer algebraic model. The  $k$ - $\epsilon$  model predicted the correct ignition delay, while the algebraic model immediately ignited at the injection point.

## Significance

It is unclear how these turbulence models will perform for more realistic geometries. Emphasis is placed on comparing the capabilities of several turbulence models for more complex geometries and flow fields of engineering interest. Simulation of turbulent flows found on aircraft would provide an extremely valuable design tool.

## Future Plans

An assessment of the capabilities of different models will be made for a single-slot ejector nozzle. The investigation of turbulent flow about an F/A-18 fuselage forebody with wing leading-edge extension at high angle of attack will continue and the different low-Reynolds-number models will be evaluated for this flow and the contributions of the corrections for rotation and curvature. An algebraic Reynolds-stress transport model will also be implemented. The ability of the  $k$ - $\epsilon$  model to predict transition is under investigation and modifications to the turbulence model will be sought for the transition zone.

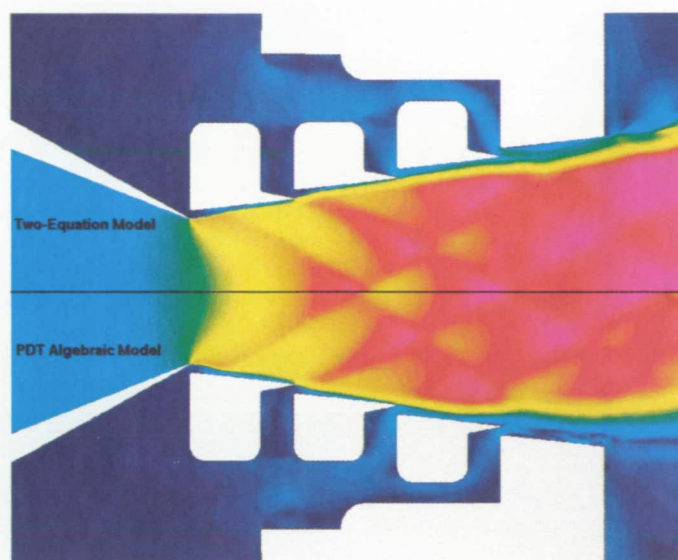

Mach number contours for (a) a multi-slot ejector nozzle using the  $k$ - $\epsilon$  and (b) Thomas algebraic turbulence models.

# Translating-Strut Scramjet Inlet

Ajay Kumar, Principal Investigator  
Co-Investigator: Dal J. Singh  
NASA Langley Research Center

## Research Objective

To investigate the effects of change in geometry by strut movement on the overall performance of an opposite-sweep sidewall compression inlet.

## Approach

A three-dimensional Navier–Stokes code is used to numerically simulate the flow through a translating-strut scramjet inlet. The inlet has variable geometry to allow for variation of the contraction ratio (CR). At low speed the CR is decreased, while at high speed the CR is increased for efficient performance of the inlet over a wide range of Mach numbers. Effects of boundary-layer ingestion on the overall flow features are also investigated. Overall flow-field features such as the corner flow, topwall separation, shock-wave coalescence, cowl pressure increase, and flow distortion at the throat are investigated. The inlet shows good characteristics at both low- and high-CR strut locations.

## Accomplishment Description

Numerical and experimental data are in good agreement, except in the separation zone where the calculations overpredict the pressure. The calculations show the need for a better turbulence model in the separation zone; the Baldwin–Lomax model is not appropriate. The ingestion of a top-surface boundary layer reduces inlet performance for both cases in terms of mass

capture, average-throat Mach number, and pressure recovery. The presence of the boundary layer also decreases the uniformity of the air profile entering the combustor. The accompanying figure shows Mach-number distribution in the inlet at various axial locations and along the cowl plane for the low-CR case. It shows a complex system of shock waves, expansion waves, and their interaction with each other and the boundaries. The two counter-rotating vortices and the large region of low-momentum flow near the top wall are clearly visible. An average run used 20 megawords of memory and took 4 Cray-2 hours.

## Significance

The present numerical investigation of a translating-strut inlet, when complemented with the wind tunnel tests, could have a favorable impact on the National Aero-Space Plane inlet design in particular, and high-speed inlets in general.

## Future Plans

Efforts are under way to investigate the inlet unstart.

## Publication

Singh, D. J.; Trexler, C.A.; and Hudgens, J. A. "Three-Dimensional Simulation of a Translating-Strut Inlet." AIAA Paper 92-0270, Jan. 1992.

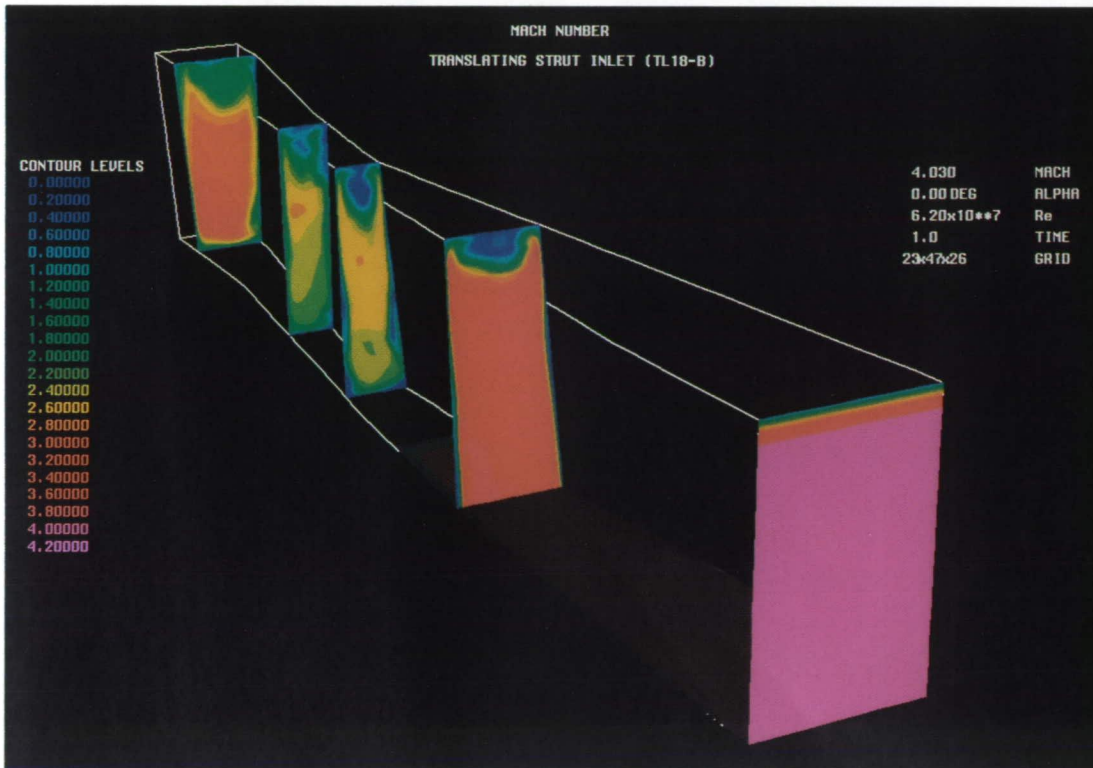

Mach number translating-strut inlet.

# High-Lift Aerodynamic Flow

Dochan Kwak, Principal Investigator  
Co-Investigators: Stuart Rogers and Lyn Wiltberger  
NASA Ames Research Center

## Research Objective

To accurately and efficiently perform numerical simulations of flow over high-lift aerodynamics configurations.

## Approach

Existing two- and three-dimensional incompressible Navier–Stokes flow solvers (INS2D-UP and INS3D-UP) were used with a multi-zonal, overlaid Chimera-grid approach to simulate the flow over two-dimensional multi-element airfoils and three-dimensional wing configurations. Both Baldwin–Lomax and Baldwin–Barth turbulence models were used.

## Accomplishment Description

The INS2D code was run on a number of different multi-element airfoil configurations. Good agreement with experimental results was obtained for most cases; however, there is a problem with the turbulence model's ability to handle significantly separated cases. The Baldwin–Barth model performed better than the Baldwin–Lomax model. Most of the computing time was used by the INS3D-UP code to compute a number of different wing flows. Good quantitative agreement with the experiment was obtained for several basic wing shapes. Some high-lift computations were performed over a rectangular wing with vortex fences

(shown in the accompanying figure). The fences supplemented the lift of the wing by trapping a vortex on the top surface of the wing. A typical coarse-grid wing configuration using 100,000 grid points requires a half-hour of Cray-2 time and 5 megawords of memory. A finer grid calculation using 500,000 grid points requires 3–4 Cray-2 hours and 25 megawords of memory. A fine grid calculation of flow over a four-element airfoil using 35,000 points can be obtained in 4 Cray-2 minutes.

## Significance

We have shown the capability to compute significantly complex, high-lift flow problems. These problems are important to aircraft designers and are a pacing item of research in the aircraft industry. The ability to run many two-dimensional jobs in a very short time will significantly impact the design process. Currently, there is a great need for this capability in three dimensions.

## Future Plans

We will further test and develop turbulence models for high-lift aerodynamic flows in two and three dimensions. Testing the flow over a three-dimensional wing in landing configuration (with flaps and slats deployed) is planned.

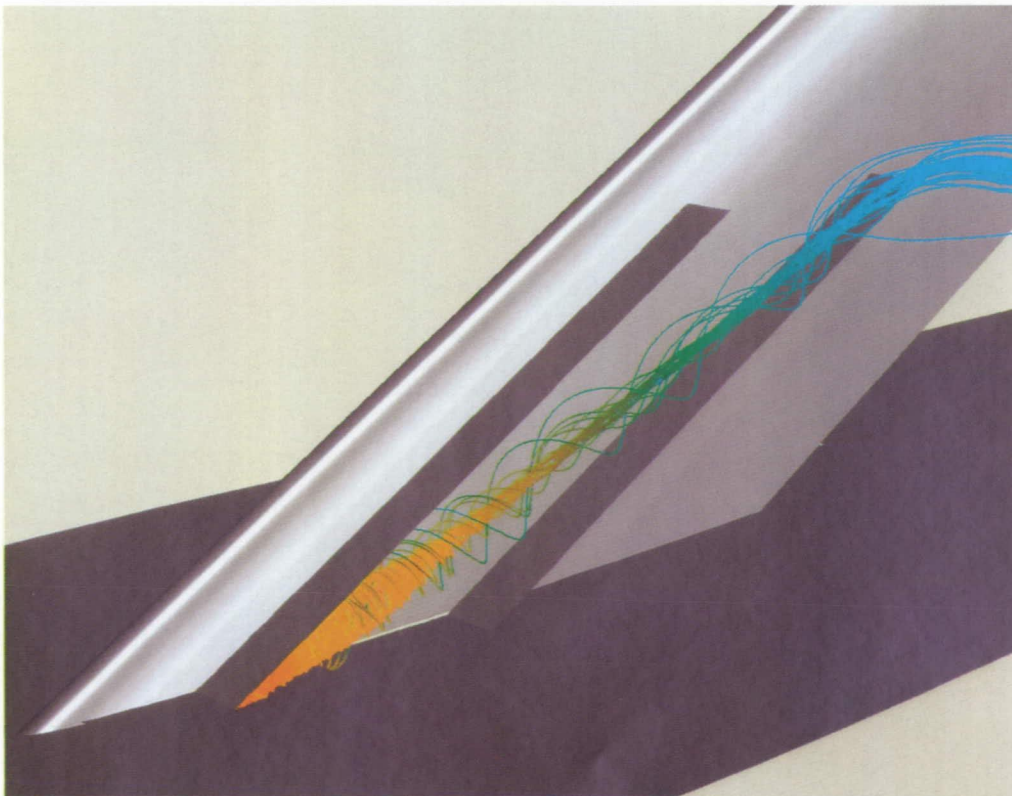

Particle traces showing the vortex formed in the flow over a wing with vortex fences. The particle traces are colored by pressure; blue = low pressure and orange = high pressure.

# Space Shuttle Main Engine Flow

Dochan Kwak, Principal Investigator

Co-Investigators: S. Yoon, C. Kiris, L. Chang, and R. Williams

NASA Ames Research Center

## Research Objective

To extend, validate, and apply incompressible Navier–Stokes solvers to computational fluid dynamics analysis of liquid rocket-engine pump components.

## Approach

The three-dimensional incompressible Navier–Stokes equations in generalized coordinates are solved in steadily rotating frames of reference. The solution is based on a pseudo-compressibility approach with two different numerical algorithms. The first algorithm, INS3D-UP, uses higher-order upwind differencing and the Gauss–Seidel line-relaxation scheme. The second algorithm, INS3D-LU, is based on the lower-upper symmetric Gauss–Seidel implicit scheme.

## Accomplishment Description

Two major components of a rocket-engine pump have been investigated: the Rocketdyne inducer and the advanced pump-impeller. As a benchmark problem, the flow through the Rocketdyne inducer is numerically simulated. A typical calcula-

tion requires 8 megawords memory and 12 Cray-2 single-processor hours. A coarse-grid solution is obtained with a single zone by using an algebraic turbulence model. Numerical results, in the form of relative velocity and relative flow angles, compare fairly well with experimental data. Multi-zone fine-grid computation uses a one-equation Baldwin–Barth turbulence model derived from a simplified form of the standard  $k$ - $\epsilon$  model equations. In recent computations, a bull-nose cavity analysis is included.

## Significance

An efficient and robust design-stage solution for three-dimensional pump flows was developed and validated. Computational analysis of new design variations for rocket engines will expedite the development of future heavy-lift launch vehicles.

## Future Plans

We are continuing the study by generally simulating future rocket engines.



*Geometry*

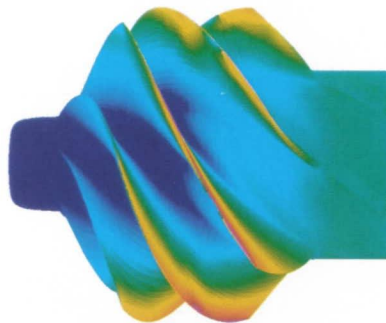

*Surface Colored  
by Pressure*

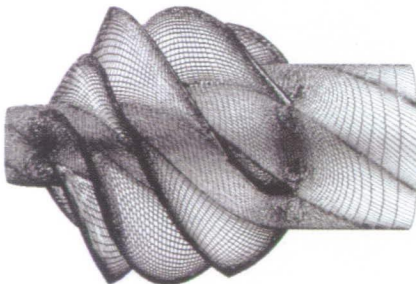

*Computational  
Grid*



*Meridional Plane  
Velocity Vectors*

*Computed results of the flow through the Rocketdyne inducer.*

# Hydrogen–Air Reacting Flow Fields in Drag Reduction External Combustion

H. T. Lai, Principal Investigator  
Sverdrup Technology, Inc.

## Research Objective

To numerically simulate three-dimensional reacting flow fields in external combustion to reduce drag.

## Approach

The finite-volume RPLUS code recently developed for reacting flows is employed to compute the solutions of compressible laminar Navier–Stokes and species equations. The numerical scheme has a lower–upper solver requiring only scalar inversions of the flow equations, but blocks diagonal inversion of the species equations because of the chemical source terms. Finite-rate chemistry of hydrogen and air is used based on a combustion model containing 18 reaction steps and nine species with nitrogen assumed inert.

## Accomplishment Description

Numerical flow fields have been computed to simulate an external burning experiment to study external combustion as a mechanism for drag reduction in aerospace vehicles when operating in the transonic regime. The model consists of a small, flat plate connected to a 12 degree expansion ramp, representing a typical underside of hypersonic nozzle walls facing the ambient flow. An air stream flows over the model at Mach 1.26 and hydrogen fuel is sonically and transversely injected along a row of 26 orifices upstream from the expansion corner. A flame holder to stabilize combustion is installed at the expansion corner downstream from the injection. Self-sustained combustion behind the flame holder can be numerically achieved using ignition by increasing fuel temperature initially and then reducing it to the desired level after combustion has been established in the flow field. Results are compared to measured data for code validation. The computations are performed on a multiblock grid of  $48 \times 50 \times 96$  simulating only half of the model. The converged solution requires 350 Cray-2 hours and 25 megawords of memory.

## Significance

Numerical prediction is consistent with the external burning experiment, confirming possible hydrogen–air combustion at low speeds. This can be used for drag reduction in hypersonic vehicles when operating at the off-design transonic-flow conditions.

## Future Plans

This study is complete.

## Publication

Lai, H. T. "Computation of H<sub>2</sub>/Air Reacting Flowfields in Drag Reduction External Combustion." AIAA Paper 92-3672, July 1992.

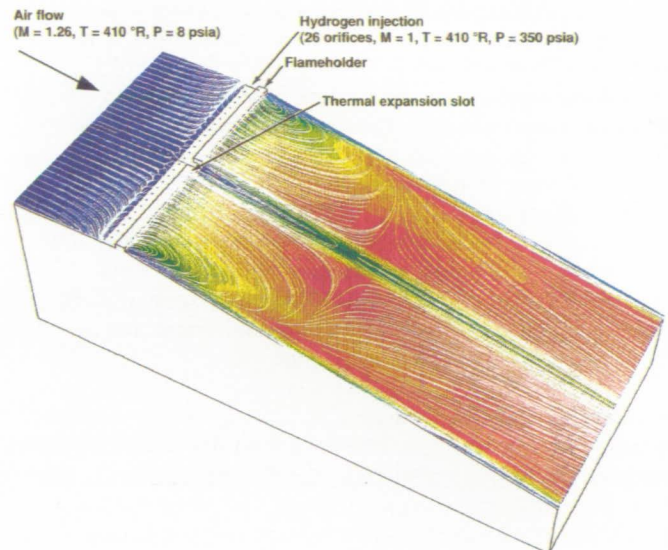

*The model shows external combustion. Near-surface temperatures are colored and the particle traces are white.*

# Steady and Unsteady Turbomachinery Flow Fields

Budugur Lakshminarayana, Principal Investigator  
Co-Investigators: S. Fan and R. Kunz  
Pennsylvania State University/General Motors Technical Center

## Research Objective

To develop and apply explicit steady three-dimensional Navier–Stokes and unsteady Euler procedures for computation of complex turbomachinery flow fields. To improve the understanding of particular flow phenomena, including secondary flows and radial mixing, tip-clearance effects, wake decay and transport, and the influence of Reynolds-stress anisotropy on mean flow fields. To develop an efficient time-accurate solution to resolve rotor/stator interaction and develop turbulence modeling approaches for these applications. We will investigate stability and accuracy issues associated with the numerical and modeling strategies employed.

## Approach

A compressible explicit flow solver was developed to perform inviscid and viscous two- and three-dimensional steady and unsteady turbomachinery flows. Numerical and turbulence-modeling strategies were developed, implemented, and evaluated to achieve more robust and more accurate mean-flow predictions for a wide class of turbomachinery applications. Numerical topics addressed directly include artificial diffusion issues (stability and accuracy), time-accurate boundary-condition treatments, and numerical compatibility of two-equation and Reynolds-stress transport models. Several complex turbomachinery flows for which experimental data were available were analyzed to calibrate the methods developed and to investigate flow phenomena of interest.

## Accomplishment Description

A three-dimensional explicit steady full-Navier–Stokes capability has been developed that incorporates two-equation and algebraic Reynolds-stress transport models. The numerical stability issues associated with incorporating transport turbulence models in an explicit solution procedure were investigated and quantified. The procedure was used to perform viscous simulation studies in several three-dimensional turbomachinery blade-row configurations. The code has been modified to obtain time-accurate solutions. Wake transport through a flat-plate cascade has been computed.

## Significance

These efforts should be useful to the turbomachinery research and development community. They include accuracy and numerical compatibility issues of current and new turbulence models and the ability of Navier–Stokes codes to reconcile important three-dimensional and unsteady-flow physics.

## Future Plans

Efforts include development and installation of turbulent heat-transfer modeling for compressible turbine flows, enhanced coupling of the unsteady algorithm with an unsteady boundary-layer code, and further centrifugal compressor flow research.

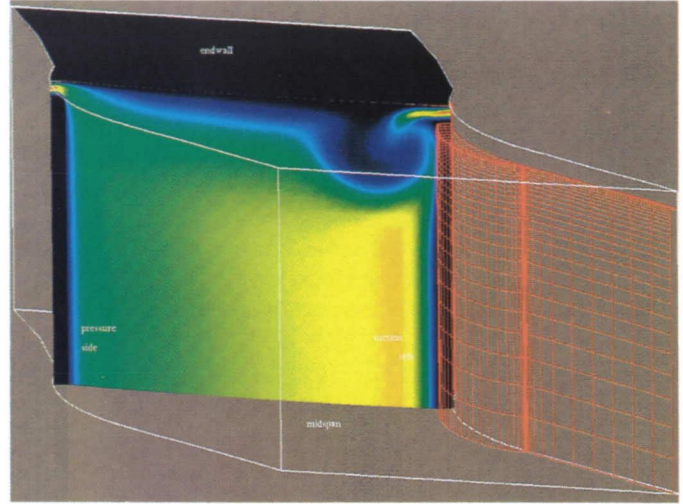

Computed contours of dynamic pressure just aft of midchord in a compressor cascade with tip clearance. High-momentum jet-like fluid in the tip-gap region and low-momentum fluid associated with the tip-clearance vortex and endwall boundary layer are evidenced.

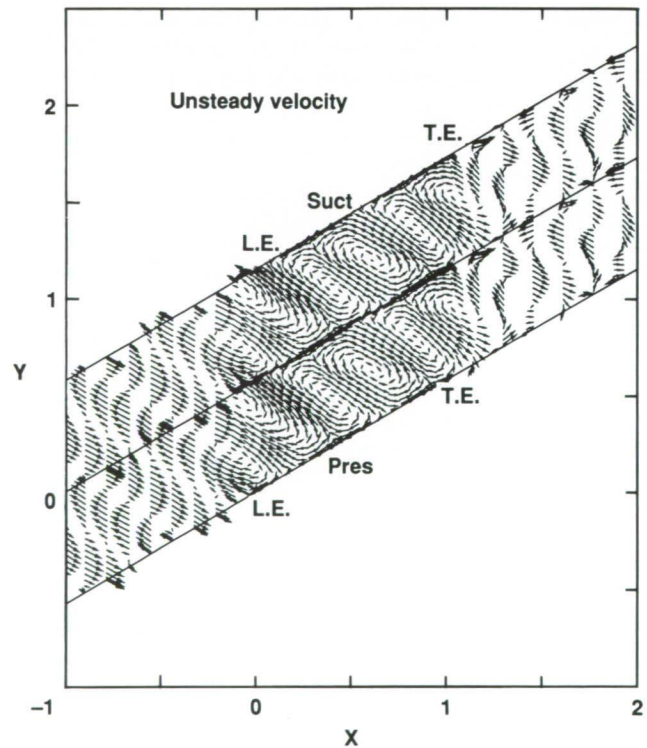

Vector plot of unsteady velocities for a flat plate cascade with incoming gust.

# Steady and Unsteady Viscous Flow

Budugur Lakshminarayana, Principal Investigator  
Co-Investigators: Yin-Hsiang Ho and Anton Basson  
Pennsylvania State University

## Research Objective

To develop an efficient and accurate numerical analysis for the prediction of steady and unsteady turbulent flows in turbomachinery applications.

## Approach

The technique developed is for incompressible flow and is an extension of the pressure-based method. A finite-volume approach with a non-stagger grid formulation is used in the analysis. A predictor-corrector type algorithm is applied to the governing equations to ensure the time accuracy and the convergence are improved using a multigrid scheme. A low-Reynolds form of a two-equation turbulence model is used to simulate the turbulent flow.

## Accomplishment Description

The unsteady flow field in a flat-plate cascade (at seven different reduced frequencies of the inlet gust, two Reynolds numbers, and two different steady loadings) has been computed. Detailed interpretation of the effects of reduced frequency and Reynolds number on the aerodynamic response function is carried out. In addition, unsteady flow through a compressor cascade, for which flow data are available, is computed and correlated with the existing experimental data. The agreement between the predicted and the measured blade-pressure and the wake data is good. The flow field over an airfoil with a separation bubble is computed with good agreement between the time-averaged values and the data. In addition, three-dimensional viscous flow through the tip-clearance gap of a turbine is computed and good agreement with the measured data is shown in the accompanying figure. Each two-dimensional unsteady-flow computation required approximately 1–2 Cray-2 hours and 4 megawords of memory. For three-dimensional tip-clearance flow, each run required 4–6 Cray-2 hours and 16 megawords of memory.

## Significance

The ability to simulate the unsteady viscous flow inside the airfoil cascade is a prelude to the prediction of rotor/stator interaction and noise generation in turbomachinery. A better understanding of the flow field inside the turbomachinery through three-dimensional viscous flow simulation can improve the performance and design of turbomachinery.

## Future Plans

We will extend the code to include the three-dimensional effects. To simulate the unsteadiness caused by the upstream stator wake flow on a rotor, an instability wave model will be employed to estimate the characteristic length and time scales of the wake flow. The small-scale motion can be modeled by the traditional two-equation model which provides a statistical description of non-isotropic, nonhomogeneous turbulence.

## Publications

1. Ho, Y. H. and Lakshminarayana, B. "Computation of Unsteady Viscous Flow using an Efficient Algorithm." AIAA Paper 91-1597, 1991.
2. Basson, A. H.; Kunz, R. F.; and Lakshminarayana, B. "Grid Generation for Three-Dimensional Turbomachinery Geometries including Tip Clearance." AIAA Paper 91-2360, 1991.

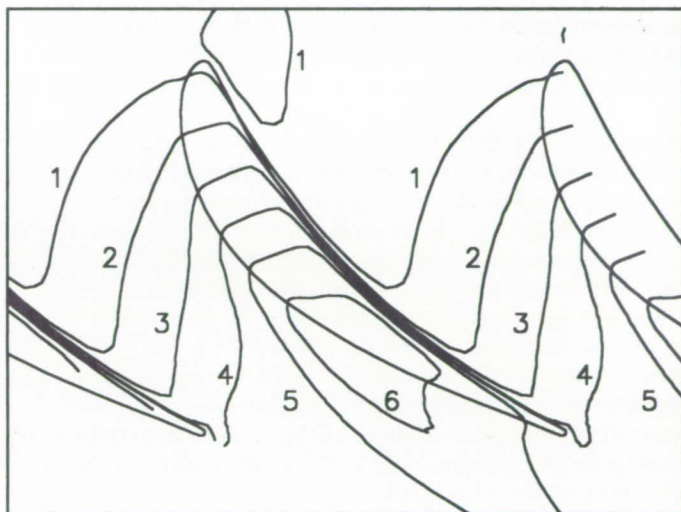

*Computed pressure coefficient contours on the endwall of the tip-clearance region.*

# Integrated Hypersonic Vehicle Flow-Field Analysis

Scott L. Lawrence, Principal Investigator

Co-Investigators: Bradford C. Bennett and Gregory A. Molvik  
NASA Ames Research Center/MCAT Institute

## Research Objective

To develop the capability to compute the entire aerothermal environment of a vehicle configuration (tip-to-tail capability), such as the National Aero-Space Plane (NASP), in hypersonic flight, including the forebody external flow, and the flow into the inlet, through the combustor, and onto the afterbody/nozzle portion of the vehicle.

## Approach

The compressible Navier–Stokes (CNS) and upwind parabolized Navier–Stokes (UPS) codes solve the Navier–Stokes and parabolized Navier–Stokes (PNS) equations using algorithms appropriate for high-Mach-number flows. The UPS code is used for streamlined regions of a configuration. The zonal methodology employed by the CNS code makes it well suited for complex portions of the vehicle such as inlets, wings, and fins. Both codes include turbulence, transition, equilibrium and finite-rate air chemistry models. In addition, the codes TUFF and STIUFF have recently been developed for flows requiring a fully coupled finite-rate chemistry capability.

## Accomplishment Description

Computations were completed examining the effects of various parameters such as bluntness, gas model, grid density, and marching-step size on forebody performance. Perfect-gas results of the bluntness study were compared with results of a wind tunnel study and generally showed good agreement with measured surface-pressure and heat-transfer data (see the accompanying figure). Each of the forebody computations required approximately 2 Cray-2 hours, including time required for the time-dependent nose solution, and 4 megawords of memory. Computational design studies were performed for a wave-rider configuration using TUFF. A hydrocarbon combustion-chemistry model is being implemented in this code for future propulsion-system design studies.

## Significance

Because ground-based facilities are unable to simulate the environment that the NASP will encounter, numerical simulations are required to assess the importance of real-gas effects on the NASP flow field, particularly their impact on the flow properties at the engine inlet.

## Future Plans

A tip-to-tail computation is under way and should be completed during the next NAS Operational Year. This computation will be followed by more detailed investigation of the combustor flow-field physics pursuant to the implementation of an advanced-turbulence/chemistry-interaction model for reacting shear layers. Finally, advanced wall-catalysis boundary conditions will be included within the PNS solver.

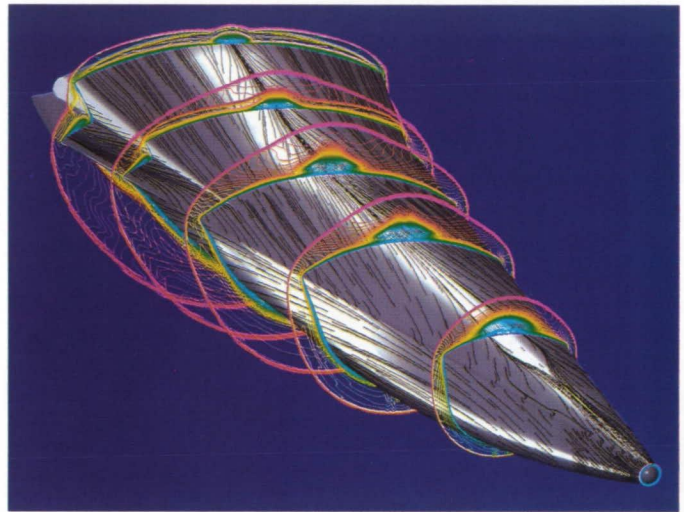

*An equilibrium air-chemistry model showing Mach contours and surface streamlines for Mach 16 flow past the Generic Option II forebody.*

# Numerical Investigation of Vehicles Similar to the National Aero-Space Plane

C. C. Lee, Principal Investigator

Co-Investigators: William Bower, Shawn Hagmeier, Brad Hopping, Morzata Mani, Scott Van Horn,

Charles Vaporean, Patrick Vogel, and Darrell Weber

McDonnell Douglas Corporation

## Research Objective

To calibrate computational fluid dynamics (CFD) codes related to the National Aero-Space Plane (NASP) using existing data and to perform parametric studies using the calibrated CFD codes to aid in the design of vehicles similar to the NASP.

## Approach

Three-dimensional Navier–Stokes codes (CFL3DE, e<sup>Malik</sup>, NASTD, MDCFPNS3D, MDCPNS) are continually upgraded and calibrated for external- and internal-flow analysis. These calibrated codes are applied in the design and evaluation of hypersonic NASP vehicles to improve the vehicle shape and supply vehicle performance parameters.

## Accomplishment Description

A Mach 10 hypersonic cruise vehicle was selected for preliminary design analysis using the parabolized Navier–Stokes (PNS) code MDCPNS. The preliminary analysis was performed on a simplified vehicle (no wings, tails, or scramjet engine package). The analysis covered the majority of the flight envelope from  $M_\infty = 2$ –10 at  $\alpha = 4$  degrees. Runs were made on a 1.97% scale model at wind tunnel conditions ( $Re_\infty/L = 2.0E6$  1/ft) and for the full-scale vehicle along the flight trajectory, including equilibrium air thermochemistry. The results included (1) the bow shock shape, which was used to design and place the wings and tails, (2) pre-tunnel flow fields, to estimate sting loads and aid in the placement of instrumentation, (3) tunnel-to-flight scaling for aerodynamic forces and moments, and (4) differences in inlet flow fields between tunnel and flight, especially the effect of boundary-layer thickness.

## Significance

The CFD work is essential for hypersonic vehicle design. The lower-order physics (the PNS methodology) have proven to be useful in the placement of wings and tails and for performing rapid screening of hypersonic vehicles over a flight envelope.

## Future Plans

The vehicle configuration is undergoing constant refinement. Tip-to-tail analysis is being planned using the CFL3DE, NASTD, and MDCFPNS3D codes. Work to significantly advance the state of the art in hypersonic vehicle design and performance prediction using CFD is being done.

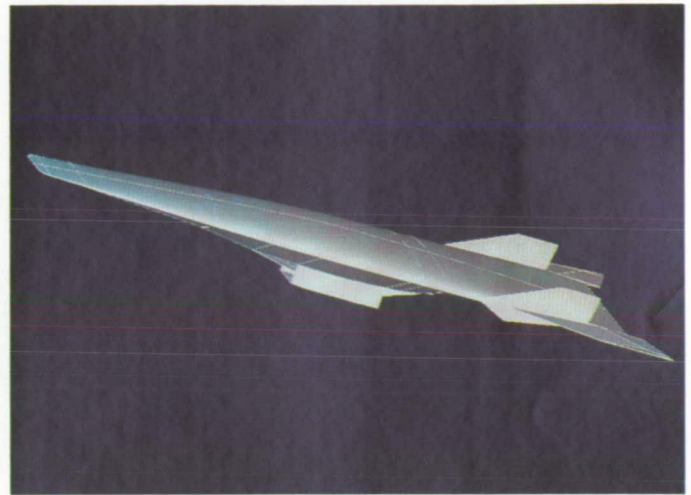

*Mach 10 hypersonic cruise vehicle.*

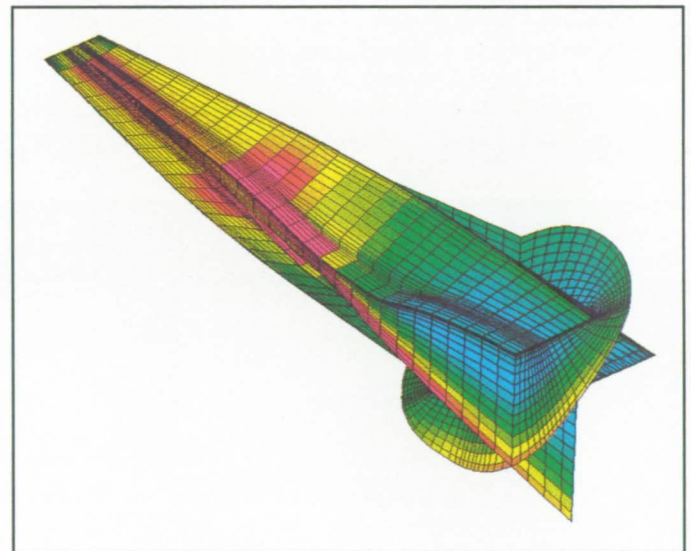

*Predicted surface and flow-field pressures;  $M_\infty = 10$ ,  $\alpha = 4$  degrees,  $h = 120$  km/ft.*

# Subsonic/Transonic Flutter Boundaries

Elizabeth M. Lee, Principal Investigator

Co-Investigator: Mike Gibbons

NASA Langley Research Center/Lockheed Engineering and Sciences Company

## Research Objective

To evaluate the aeroelastic version of the three-dimensional Euler/Navier–Stokes CFL3D code for wing-flutter predictions. The code was modified for the aeroelastic analysis of wings.

## Approach

The configuration studied is the first Advisory Group for Aeronautical Research and Development standard aeroelastic configuration for dynamic response that was tested. The wing had a quarter-chord sweep angle of 45 degrees, a panel aspect ratio of 1.65, a taper ratio of 0.66, and a NACA 65A004 constant-airfoil section. The mounted model is shown in the accompanying figure. Flutter data for this model are reported over a range of free-stream Mach numbers from 0.338 to 1.141. The flutter-speed index versus Mach number for this model exhibits the characteristic transonic dip near Mach 1.

## Accomplishment Description

The aeroelastic version of CFL3D in the Euler mode was used to compute a complete flutter boundary for the 45 degree swept-back wing. The grid contained 261,129 grid points and required approximately 26 megawords of memory for a transient calculation. Flutter analyses were performed at free-stream Mach numbers of 0.338, 0.678, 0.90, 0.96, 1.07, and 1.14. The determination of the flutter point at each Mach number required one steady-state calculation which was used as a starting point

for several transient calculations at varying dynamic pressures. The dynamic pressures were chosen so that the wing response varied from stable, at a lower dynamic pressure, to unstable, at a higher dynamic pressure, thus bracketing the flutter point. Each flutter-point prediction required approximately 26 Cray-2 hours. The results of the analyses are compared to the experimentally determined flutter-speed index and flutter-frequency ratio and are shown in the figure. This shows that at subsonic free-stream Mach numbers, the computed flutter-speed index agrees well with the experimental value while the computed frequency ratio is slightly below the experimental values and the frequency ratio agrees well with the experimental value. Past Mach 1, where the flutter boundary is particularly sensitive to Mach number, the computed boundary indicates a sharper rise than the experimental boundary.

## Significance

The good agreement between the computed and experimental values tends to validate the unsteady-Euler aerodynamic method for subsonic and transonic Mach numbers.

## Future Plans

We will investigate the differences in the predicted flutter speeds for the supersonic free-stream Mach numbers using the Navier–Stokes equations and apply this aeroelastic analysis method to a National Aero-Space Plane configuration.

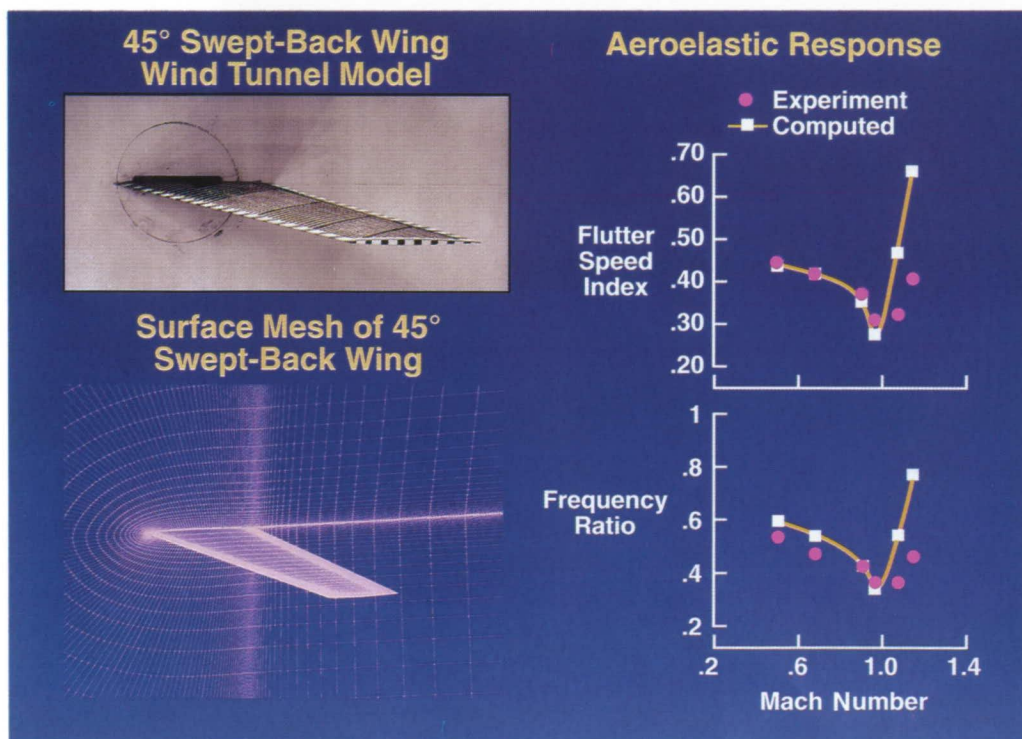

Subsonic/transonic flutter boundary computed using an unsteady-Euler aerodynamic method.

# Resonant-Triad Interaction in an Adverse Pressure-Gradient Boundary Layer

Sang Soo Lee, Principal Investigator

Co-Investigator: M. E. Goldstein

Sverdrup Technology, Inc./NASA Lewis Research Center

## Research Objective

The nonlinear resonant-triad interaction for a Blasius boundary layer is analyzed for an adverse pressure-gradient boundary layer.

## Approach

Our interest is in the nonlinear interactions that arise from the continued downstream growth of a resonant triad of initially linear instability waves. We assume that the adverse pressure gradient is weak and, therefore, that the instability growth rate is small. This ensures that there is a well-defined critical layer located somewhere within the flow and that the nonlinear interaction is effectively confined to that layer. In the initial interaction, the oblique instability waves exhibit faster than exponential growth and the growth rate of the two-dimensional mode remains linear. This is known as "parametric resonance." The interaction becomes fully nonlinear and the growth rates become fully coupled once oblique-mode amplitudes become sufficiently large. However, the coupling terms are now quartic. More importantly, new nonlinear interactions now come into play and eventually have a dominant effect on the instability-wave development.

## Accomplishment Description

The amplitude equations, which are fully coupled integro-differential equations, are solved numerically. The results are

obtained by using the Adams–Moulton method with variable orders (up to the twelfth) to advance the solutions downstream from the prescribed upstream linear states. The integral terms on the right sides of the amplitude equations were computed by using the eleventh-order (9 point) Newton and Cotes integration formula with the upstream "tails" evaluated analytically from the upstream linear solutions. The code required about 4–8 megawords of memory and approximately 2 Cray Y-MP hours.

## Significance

Linear growth of the two-dimensional mode allows the amplitude to reach a level that produces a parametric resonance in the oblique modes, which then allows them to grow at an accelerated rate until they become large enough to interact with themselves. This self-interaction produces a further enhancement in their growth, ultimately ending in a singularity at a finite downstream position. This explosive growth is then transferred to the plane wave through the mutual interaction and back-reaction terms.

## Future Plans

In order to compare experimental results, we need to include the viscosity effect. We will study that by solving a set of partial differential equations.

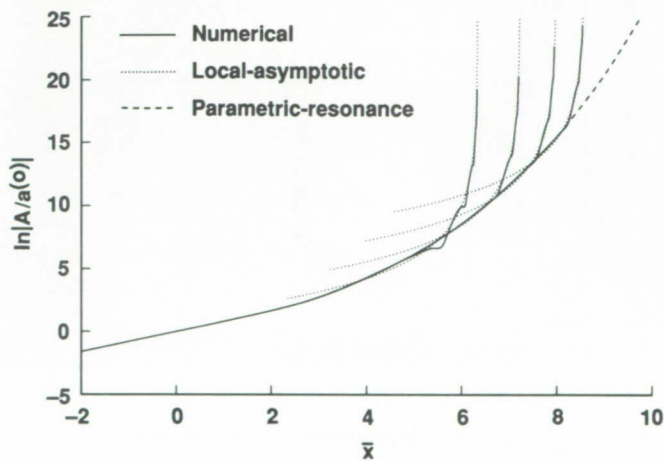

Magnitude of the oblique instability-wave amplitude versus streamwise distance for different initial amplitudes (from left to right, 0.1, 0.01, 0.001, 0.0001); solid lines = numeric, dotted lines = local-asymptotic, dashed lines = parametric-resonance.

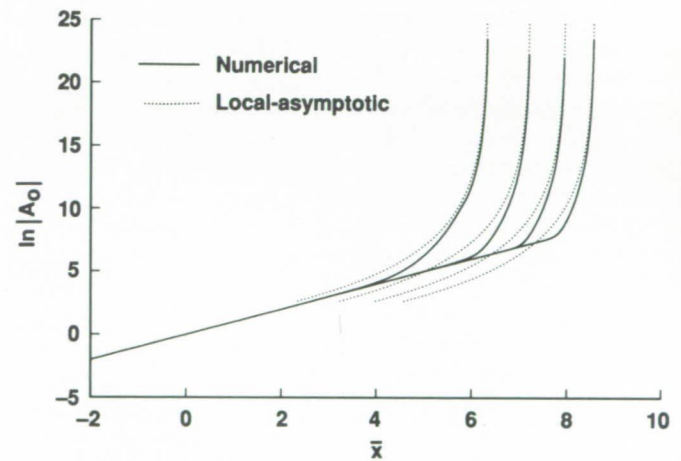

Magnitude of the plane instability-wave amplitude versus streamwise distance.

# Unsteady Flows for Naval Applications

Yu-Tai Lee, Principal Investigator  
Naval Surface Warfare Center

## Research Objective

To develop a numerical design tool for an axial turbomachine to predict flow unsteadiness and associated aeroacoustics in order to improve the turbomachine's efficiency and reduce its noise level.

## Approach

A three-dimensional time-accurate Euler method was developed for inviscid flow through rotor/stator geometries. The rotor and stator are defined separately in local moving coordinates that are attached to each of them. The time-stepping technique is used to carry out the time-accurate inviscid flow analysis. To enhance computational efficiency, which is crucial to a time-accurate calculation method for such complex geometries, a new Gauss-Seidel successive iterative procedure is used. This is necessary to solve the massive system equation devised for the geometrically thin rotor/stator blade surfaces. A linear relationship between the perturbed pressure on the blade surface and the wake vortex is presented in an analytical-matrix form that most effectively and efficiently enables us to implement the nonlinear pressure-type Kutta condition.

## Accomplishment Description

Numerical results for a stator/rotor cascade were carried out and strong interaction between the shed vortex and the downstream blade is seen. An unsteady calculation takes approximately 5 Cray Y-MP hours for 300 time steps. The method was used to redesign a shipboard high-pressure ventilation fan. The original fan could not meet the aeroacoustic and aerodynamic performance requirements of a narrow range of flow rate versus pressure rise required by the system it was installed in. Utilizing the present method enabled designers to screen candidate geometries accurately and efficiently. The noise level for the new fan (shown in the accompanying figure) is about 20 decibels lower than the original fan. A complete design case takes about 50 Cray Y-MP hours.

## Significance

These solutions are important in understanding the physics of rotor/stator flows and provide an efficient and effective analysis tool for early stages of design.

## Future Plans

We will deduce numerical modeling and predictions for marine propellers.

## Publications

1. Lee, Y. T.; Bein, T. W.; Feng, J. Z.; and Merkle, C. L. "Unsteady Rotor Dynamics in Cascade." ASME Paper 91-GT-147, 1991.
2. Lee, Y. T.; Feng, J. Z.; Slipper, M. E.; and Merkle, C. L. "Redesign of an Incompressible High-Pressure Fan using CFD." 37th ASME International Gas Turbine Conference, Cologne, GE, June 1992.
3. Lee, Y. T. and Bein, T. W. "Unsteady Pressure and Flow of Blade Interactions." Displayed at the 4th Navy IR/IED Symposium, Laurel, MD, 1991.

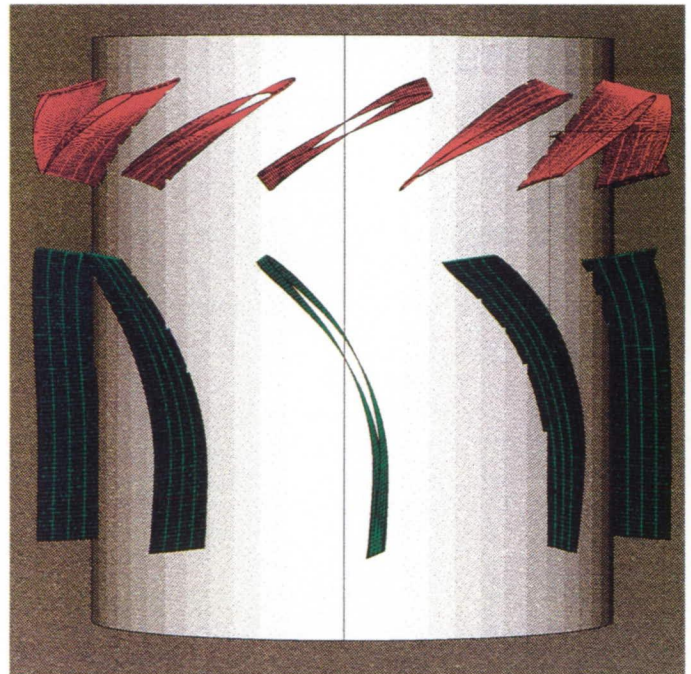

*Redesigned shipboard high-pressure ventilation fan.*

# Skewed Compressible Mixing Layers

Sanjiva K. Lele, Principal Investigator  
Stanford University

## Research Objective

To determine the effects of free-stream skewing on the behavior of compressible mixing layers.

## Approach

Three-dimensional unsteady Navier–Stokes equations are solved for the skewed mixing-layer flows using the linear-stability analysis of the skewed three-dimensional flow to prescribe inflow disturbances. The unsteady dynamics of the large-scale structures and the overall statistical evolution of the flow is studied.

## Accomplishment Description

A pre-existing computer code for solving the three-dimensional unsteady Navier–Stokes equations was adapted for our purposes. To prescribe the inflow conditions, the linear stability problem for a three-dimensional skewed mixing-layer laminar basic flow was formulated and solved. The instability results were analyzed to isolate the effects of free-stream skewing and flow compressibility. Under incompressible conditions the skewing effect was found to increase the maximum spatial amplification rate by a factor of three for  $U_2/U_1 = 0.5$  and by a factor of nine for  $U_2/U_1 = 0.75$ , with the most amplified wave propagating in the direction of effective mean shear. Compressibility decreased the skew-induced enhancement. For unskewed mixing layers at a convective Mach number of 0.8, the effect of skewing was a mild increase in the growth rate. A scale was developed to quantitatively explain the skewing effect and this allowed an effective convective Mach number to be defined and isolated the compressibility effect. Results of the analysis were incorporated into the three-dimensional nonlinear simulations and further work on the simulations is currently under way. Preliminary results from the simulations show that the vortical structures developing in a skewed mixing layer are more complex and three-dimensional.

## Significance

The skewing effects on mixing layers can now be estimated. Enhanced instability may lead to more effective mixing and its control.

## Future Plans

The simulation will be extended to systematically explore the effects of skewing and compressibility on the mixing layer.

## Publication

Lu, G. and Lele, L. K. "Inviscid Instability of Skewed Compressible Mixing Layers." Submitted to *Journal of Fluid Mechanics*, April 1992.



*Temporal simulation of a skewed compressible mixing layer. Contours of constant pressure have a cut of passive scalar at  $y = 0$ . Iso-surface pressure showing the rotational region is drawn with a wire mesh. The plotted pressure level is 0.55, while the minimum, maximum, and ambient pressure levels are 0.38, 1.02, and 0.71, respectively. A cut of passive scalar at the mid-position of the mixing layer is overlaid; blue = lower stream and red = upper stream. The velocity ratio = 0.6, the temperature ratio = 1, the convective Mach number = 0.8, the Reynolds number = 500, and the grid size =  $121 \times 64 \times 64$ .*

# Turbulence Effects on Stagnation-Point Flow

Sanjiva K. Lele, Principal Investigator  
Stanford University

## Research Objective

To study the effects of free-stream turbulence on stagnation-point heat transfer.

## Approach

Direct numerical simulations (DNS) are performed to study the stagnation-point heat transfer with free-stream turbulence.

## Accomplishment Description

A pre-existing computer code for solving the three-dimensional unsteady Navier–Stokes equations with periodic boundary conditions is being adapted. The stagnation-point flow requiring the incorporation of a no-slip surface was developed. Preliminary simulations of the interaction of a two-dimensional jet, with a core-flow Mach number of 0.5, impinging on a surface were performed. The flow exhibited self-sustained large-amplitude oscillations corresponding to rolled-up vortices in the jet flow. These vortices are expected to significantly change the heat

transfer at the plate surface. Simulations where the organized vortices are absent but the free-stream turbulence is imposed (such as isotropic turbulence at the inflow boundary) are currently being developed. To aid this process, asymptotic analysis of the compressible viscous stagnation-point flow was developed. The results of this analysis are being combined with the inflow free-stream turbulence prescription to conduct DNS. The impinging jet-flow simulations are being refined.

## Significance

Understanding the processes that increase the heat transfer when free-stream turbulence is present will lead to the better design of gas turbines.

## Future Plans

The simulations will be extended to three dimensions and the effect of free-stream turbulence on stagnation-point heat transfer will be studied.

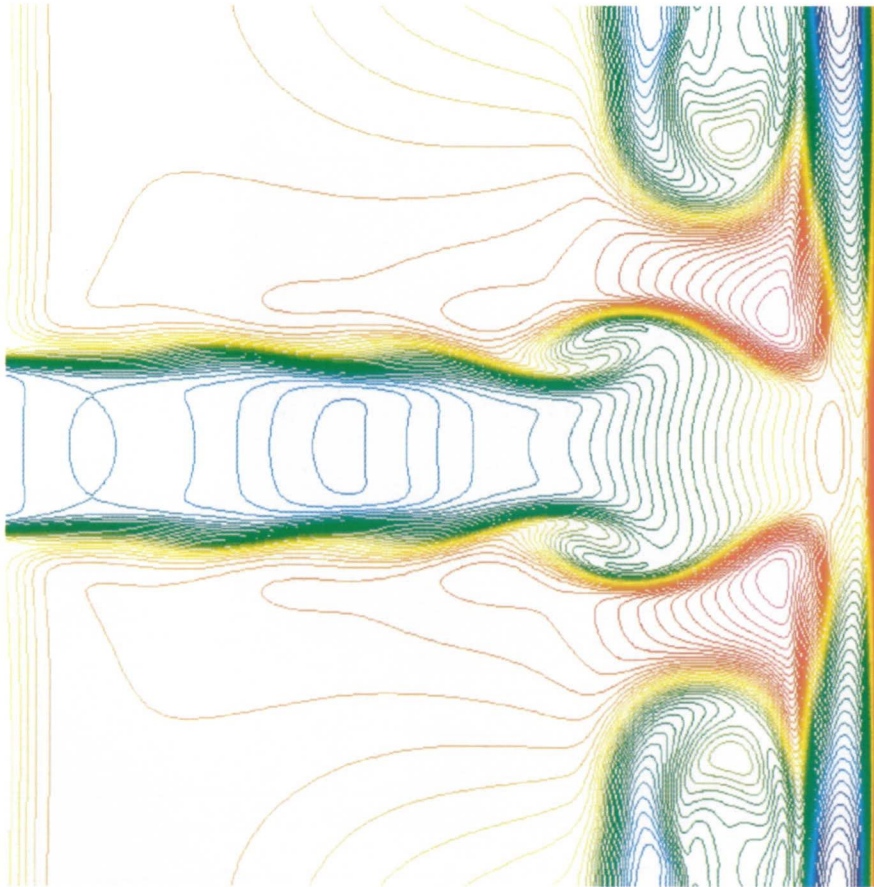

*Numerical study of free-stream turbulence effects on stagnation-point heat transfer. The temperature contours in a laminar jet (entering from the left) impinging on a flat plate (right) are shown. A thermal boundary layer can be seen as a cluster of red contours along the right wall. The data were generated with an explicit, full Navier–Stokes calculation on a  $281 \times 281$  mesh. The jet inlet Mach number is 0.5, yielding a Reynolds number of 1,000 based on the width of the jet.*

# Three-Dimensional Parabolized and Full Navier–Stokes Techniques

Clark H. Lewis, Principal Investigator  
 Co-Investigator: Bilal A. Bhutta  
 VRA, Inc.

## Research Objective

To develop fast and accurate three-dimensional parabolized Navier–Stokes (PNS) and Navier–Stokes techniques to predict effects of gas chemistry, hypersonic flows over complex lifting configurations with compression surfaces, fins, flaps, stabilizers, and other complicated control surfaces.

## Approach

A unique PNS scheme is used as the baseline. Unlike conventional PNS schemes, this three-dimensional PNS scheme does not include any sub-layer approximation. A zonal approach is used to divide the flow field into a streamwise sequence of smaller regions. In each zone, a PNS solution is done and then, if necessary, the solution is further improved by using Navier–Stokes iterations consisting of a streamwise relaxation algorithm. A new flux-vector-splitting approach is used to treat the convective flux terms for a general real-gas. An implicit shock-fitting approach is used that treats the bow shock as a sharp discontinuity and predicts its location. A hybrid differencing approach is used and involves central differencing in the smooth shock-free regions and fully upwind flux-vector splitting across embedded shocks. The computational grids are generated using a fast elliptic grid-generation scheme that requires only 15% more computing time than a corresponding cylindrical grid-generation scheme.

## Accomplishment Description

The PNS and Navier–Stokes techniques developed have been used to study perfect-gas and equilibrium-air hypersonic flows over various lifting and maneuvering configurations, re-entry vehicles (RVs), and other high-speed missiles. Hypersonic flows over a wide variety of three-dimensional multiconic shapes with and without a bent forecone, cuts and flats, strong flares, fins, and spin tabs were computed, and the predicted flow fields were found to be in excellent agreement with available data. Supersonic and hypersonic flows over typical high-speed finned-missile configurations were also analyzed to study gas-chemistry, fin-thickness, and fin-deflection effects. Calculation required 1 Cray Y-MP hour and approximately 10 megawords of memory.

## Significance

The three-dimensional PNS/Navier–Stokes techniques developed in this study will provide the basic numerical tools necessary to successfully design and operate various future and present supersonic and hypersonic aircraft, missiles, planetary probes, and RVs.

## Future Plans

We will continue to develop and extend the basic PNS and Navier–Stokes algorithm for enhanced stability and accuracy, and extend the PNS algorithm to study blunt-body flows. We will focus on extending chemical and/or thermal nonequilibrium, complex three-dimensional shapes, surface ablation, and thermal-radiation effects.

## Publications

1. Bhutta, B. A. and Lewis, C. H. "Comparison of Hypersonic Experiments and PNS Predictions, Part I: Aerothermodynamics; Part II: Aerodynamics." *Journal of Spacecraft and Rockets* 28 (July-Aug. 1991): 376–393.
2. Bhutta, B. A. and Lewis, C. H. "New Technique for Low- to High-Altitude Predictions of Ablative Hypersonic Flow Fields." *Journal of Spacecraft and Rockets* 29 (Jan.-Feb. 1992): 35–50.

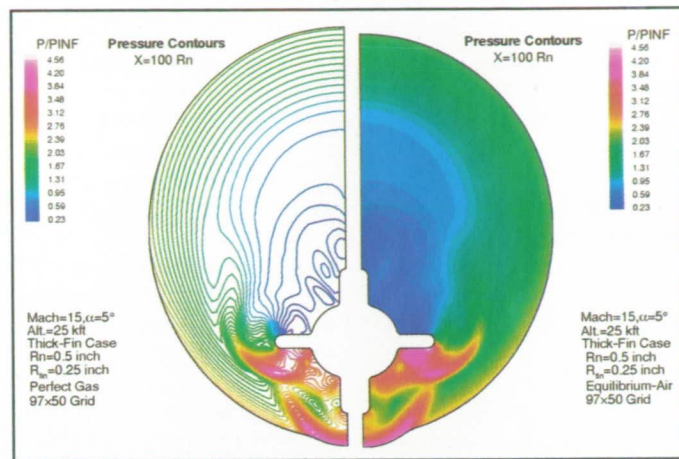

Predicted pressure distributions at the body-end of a typical finned missile at Mach 15 and 5 degrees angle of attack.

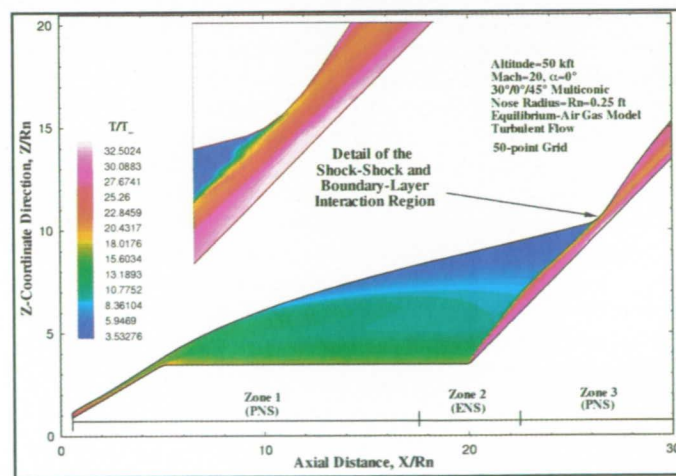

Temperature contours for a Mach 20 flow over a 45 degree flare.

# Electron-Beam Injections from the Space Shuttle

C. S. Lin, Principal Investigator

Co-Investigator: M. Muller

Aurora Science, Inc./Southwest Research Institute

## Research Objective

To examine the mechanism by which an electron beam radially expands after injection along magnetic-field lines. The electron beam is a radial expansion for better control of active experiments on the Space Shuttle. Computer simulations are conducted to study the injection of a high-density electron beam from the Space Shuttle into ambient plasma and neutral gas.

## Approach

To understand the radial-expansion mechanism of an electron beam injected from a highly charged spacecraft, two-dimensional particle-in-cell simulations are conducted for a high-density electron beam injected parallel to magnetic fields from an isolated equi-potential conductor into a cold background plasma. Realistic modeling of beam injection from a spacecraft requires injecting an electron beam from a finite isolated-conductor. Therefore, we use the capacity matrix method to treat the spacecraft surface as a finite isolated equi-potential conductor in an ambient plasma. Charged particles in the simulation system are advanced in time according to the equation of motion under the electric potentials. The procedure is repeated until the electron beam propagates to the end of the simulation system.

## Accomplishment Description

The configuration space plot in the accompanying figure shows that the electron beam expands radially to the beam's electron gyroradius. The radial expansion occurs near the stagnation point close to the conductor surface. The initial expansion determines the beam envelope after the stagnation point. The radial expansion is caused by charge build-up at the stagnation point, producing a large transverse electric field. Accelerated by the transverse electric field, the beam electrons injected parallel to magnetic fields receive a large transverse kick. The maximum perpendicular velocity gained by the beam electrons approaches the beam-injection velocity. An average job run takes about 2 Cray Y-MP hours and 4 megawords of memory.

## Significance

Beam radial expansion is important because it affects the beam diameter and density—two critical parameters in determining the propagation and instability conditions of a finite-radius electron beam. The simulation results are applicable in understanding the measurements from several electron-beam injection experiments on the Space Shuttle.

## Future Plans

The code will be used to determine the dependence of the beam radius on beam density and other plasma parameters, and will be extended to simulate the motion of spacecraft.

## Publication

Koga, J. and Lin, C. S. "Simulation of Radial Expansion of an Injected Electron Beam." To be published in proceedings of the 1991 Cambridge Workshop in Theoretical Geoplasma Physics.

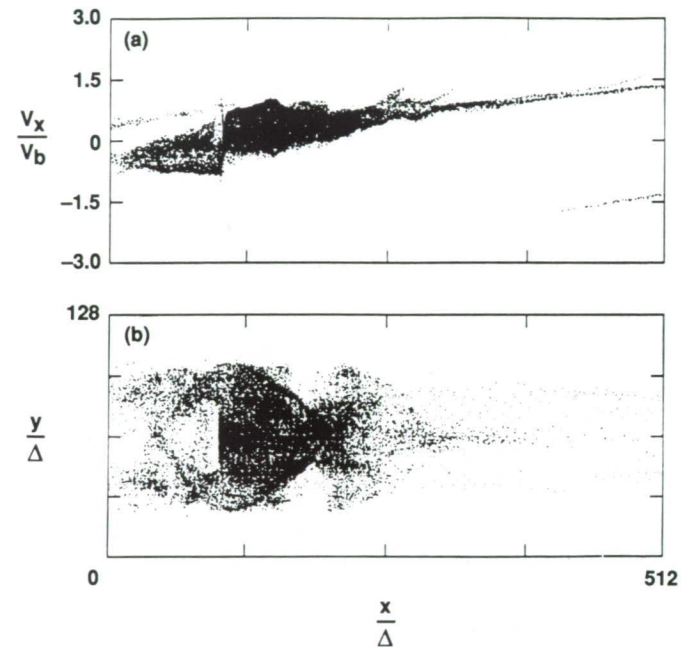

The phase space plot (top) and configuration space plot (bottom) of the beam electrons showing the simulation results. Electron beams are injected from a plate at one-fourth of the system length from the left boundary.

# Turbopump Rotor/Stator Flows

S. J. Lin, Principal Investigator  
Rockwell International, Rocketdyne Division

## Research Objective

To utilize and extend the rotor-family code to calculate dynamic loading and analyze thermal characteristics of Space Shuttle main engine (SSME) and Space Transportation main engine (STME) turbopumps.

## Approach

The rotor code was extended to be a full Navier–Stokes solver. It solves the two- and three-dimensional compressible unsteady Navier–Stokes equations on a system of patched and overlaid grids.

## Accomplishment Description

The Rotor-2 code was extended to have multistage capability and was used to do a two-dimensional unsteady simulation for a two-stage SSME high-pressure fuel turbopump multi-rotor/multi-station turbine blade. Good agreement was obtained between calculated results and NASA Marshall SSME cool-air test data. The Rotor-3 code was extended to be a full Navier–Stokes solver and was modified to compute three-dimensional steady-state subsonic SSME and supersonic STME turbine blades. Obtaining a three-dimensional steady-state solution for an isolated turbine takes 3–5 Cray-2 hours and uses approximately 100,000 grid points.

## Significance

The current STME baseline engine design utilizes a gas-generator cycle. Because of the high-pressure ratio involved, the fuel turbine is required to operate in the supersonic regime. To date, only limited three-dimensional computational fluid dynamics analysis has been performed for supersonic turbine blades. Successful simulations of supersonic turbine-blade flows (steady or unsteady) will provide accurate predictions of blade dynamic-loading and thermal characteristics that will help improve the performance and design of turbopumps.

## Future Plans

The rotor code will be extended to calculate dynamic loading and thermal characteristics of the turbine blade in three dimensions. The upgraded code will be validated for supersonic turbine-blade flows and applied to support STME fuel-turbine design.

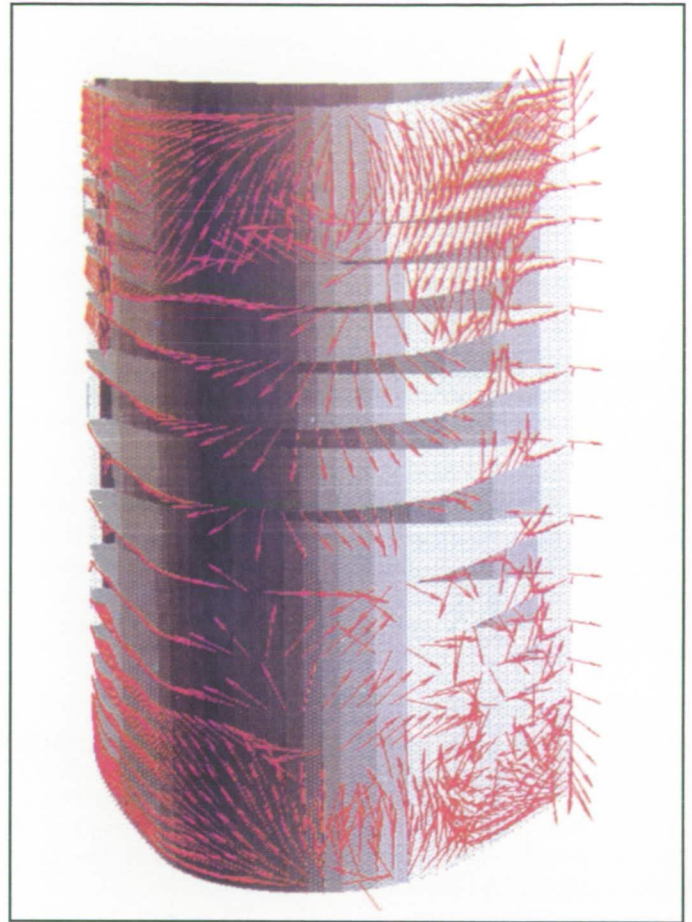

*The velocity field indicates flow separation due to shock/boundary-layer interaction. The flow-separation region is at the suction side and near the blade leading edge.*

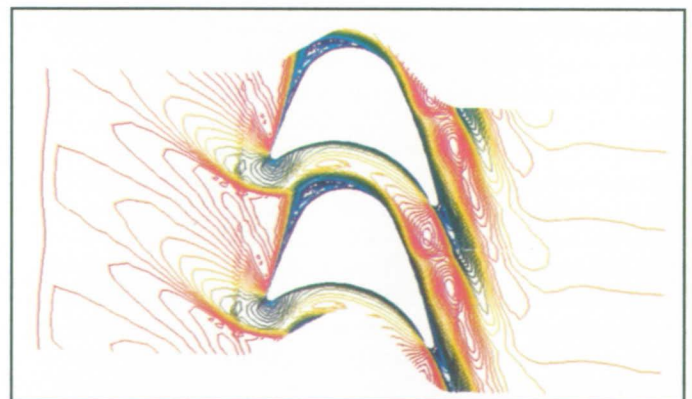

*Mach number distribution at the midsection of the Mark-44 supersonic turbine. A shock occurs at the suction side and near the blade leading edge.*

# Advanced Computational Fluid Dynamics Applications for Complex Configurations

James M. Luckring, Principal Investigator  
Co-Investigators: Farhad Ghaffari and Brent L. Bates  
NASA Langley Research Center

## Research Objective

To extend the Navier–Stokes computations about the F/A-18 configuration to include the aerodynamic effects of wing leading-edge flap deflection.

## Approach

A high-fidelity surface definition for the complete F/A-18 aircraft has been generated in the form of cross-sectional cuts. Geometrical configuration simplifications include fairing over the inlet, splitter plate, diverter, and leading-edge-extension (LEX) slots. The deflected-flap geometry has been simplified over the inboard 15% semispan by smoothly blending the deflected-flap geometry to the undeflected-flap wing–body intersection. Subsequently, a multiblock structured-volume grid has been generated using a transfinite interpolation technique. The entire domain is represented by approximately  $1.25 \times 10^6$  grid points which are contained within 20 blocks using combinations of C-O, H-O, and H-H topologies. The flow field was computed with a version of CFL3D which has been extended for a generalized surface patching. Turbulent effects are represented by an extended version of the Baldwin–Lomax algebraic turbulence model. The computations are done without the empennage geometry.

## Accomplishment Description

The thin-layer Navier–Stokes results with turbulent flow assumption have been obtained at  $\alpha = 19$  degrees,  $R_{\tau} = 13.5 \times 10^6$ , and  $M_{\infty} = 0.34$  and correspond to flight test conditions for the F/A-18 High Alpha Research Vehicle (HARV). The computations are performed for both 0 and 25 degree wing leading-edge flap deflections. A photograph of the HARV in flight (showing the tuft-flow survey over the wing, and the LEX and part of the fuselage along with the LEX vortex core visualized via smoke) is shown in the accompanying figure. Similarly, the unrestricted surface-flow pattern and the LEX vortex-core streamlines obtained from the computational results for both the blended (starboard) and the undeflected (port) flap configuration are shown. The simulated surface tuft-flow pattern, particularly over the blended-flap configuration, qualitatively resembles those observed in-flight that indicate a massively separated and stalled flow field on the outer wing panel. However, the computational results do not predict the LEX vortex breakdown observed in flight. This result is consistent with experimental wind tunnel data obtained on an F/A-18 model and demonstrates that the vortex breakdown is induced by the presence of the vertical tail. Excellent surface-pressure correlations between computations and flight-test results are achieved on the forebody with reasonable agreement over the LEX. A typical numerical solution corresponds to two-orders-of-magnitude reduction of the residuals, requiring 3,000 cycles and approximately 20 Cray-2 hours.

## Significance

Meaningful Navier–Stokes analyses are performed on a realistic aircraft configuration including the aerodynamic effects from the wing leading-edge flap deflection.

## Future Plans

We will validate the computational results through wind tunnel experiments and perform the computations under different flow conditions.

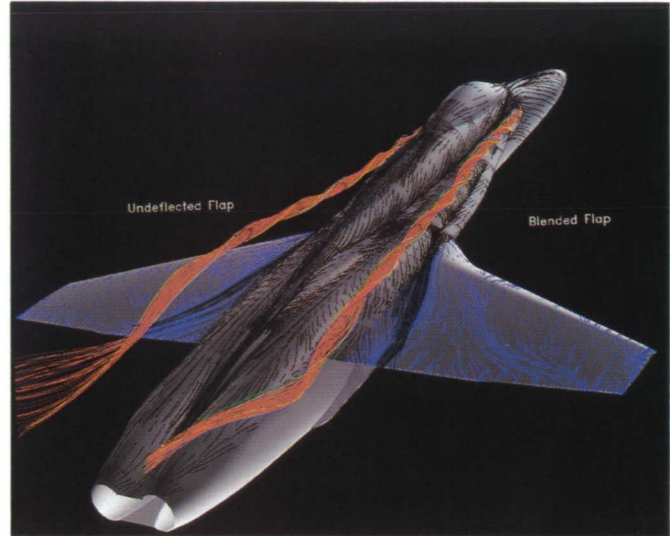

(a)



(b)

Surface/off-surface flow correlations with flight results. (a) computation;  $\alpha = 19$  degrees,  $R_{\tau} = 13.5 \times 10^6$ , and  $M_{\infty} = 0.34$ . (b) flight;  $\alpha \approx 20$  degrees,  $R_{\tau} \approx 11.5 \times 10^6$ , and  $M_{\infty} = 0.30$ .

# Ignition and Structure of a Diffusion Flame with Vortex Interaction

M. G. Macaraeg, Principal Investigator

Co-Investigators: T. L. Jackson and M. Y. Hussaini

NASA Langley Research Center/Old Dominion University/ICASE

## Research Objective

To study the fundamental physics of turbulent combustion or combustion in vortical flows relevant to high-speed propulsion devices.

## Approach

The study involves a detailed asymptotic analysis and numerical simulation of the continuous evolution of the mixing between a fuel and oxidant which are allowed to mix and react in the presence of a viscous vortex. Emphasis is placed on the ignition time and location as a function of vortex Reynolds number ( $R$ ) and initial temperature difference ( $\beta_T$ ) between the reacting species.

## Accomplishment Description

The study focuses on understanding the controlling parameters necessary for ignition in a vortical flame. Typical results show the influence of the initial temperature differential and vortex strength on ignition onset and location. Ignition is seen as a hot spot in the  $T_1$  field, displayed in the first figure. The vortical structure is slightly asymmetric due to an imposed perturbation temperature differential between the fuel and oxidant and the relatively weak vortex. As the vortex strength is increased the location of ignition moves to the center of an axisymmetric structure as depicted in the second figure. Increasing the vortex strength also reduces ignition time, which approaches a constant dependent on the initial temperature differential between the reactants. As the flame evolves, ignition occurs as a single hot spot in the viscous core and rapidly grows as time increases. At a later time, two diffusion flames begin to merge with the expanding, almost circular, flame. A typical calculation for this model on a fine grid requires 4 megawords of memory and 1 Cray-2 hour. The calculations that will be performed after the development of the ignition model for high speeds will increase this memory and time to 12 megawords and 8 Cray-2 hours.

## Significance

Reaction in a laminar diffusion flame depends on simultaneous processes of interdiffusion and chemical reaction. Some turbulent combustion processes may be described as a collection of laminar-flame structures that retain their identity but are distorted by the turbulence. No theory of ignition exists for high-speed flows. This study shows that the onset of ignition and its location in a laminar flame is strongly dependent upon the initial temperature differential and the vortex strength.

## Future Plans

Analysis and parametric studies will continue with the addition of acoustic effects and compressibility in more complex flow fields. Systematic understanding of the relevant physics will precede a model incorporating detailed chemical kinetics in a full numerical simulation.

## Publications

Macaraeg, M. G.; Jackson, T. L.; and Hussaini, M. Y. "Ignition and Structure of a Laminar Diffusion Flame in the Field of a Vortex." To be published in *Combustion Science and Technology*, 1992.

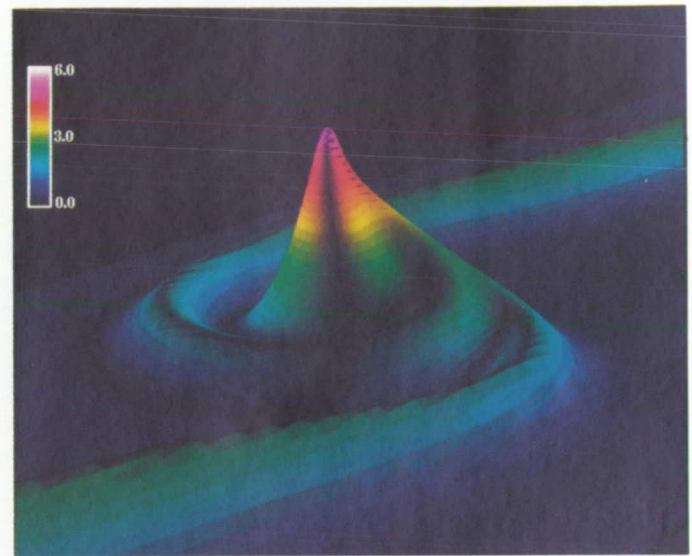

Surface plot of  $T_1$  for  $R = 28.0$  and  $\beta_T = -2$ .

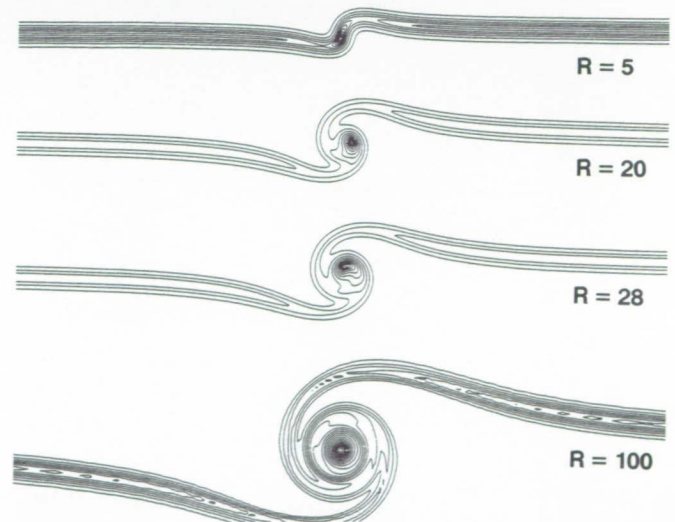

Contour plots of  $T_1$  for  $\beta_T = -2$  and increasing vortex strength.

# Computer Simulation of Water–Membrane Interfaces

Robert D. MacElroy, Principal Investigator

Co-Investigators: Andrew Pohorille and Michael A. Wilson

NASA Ames Research Center

## Research Objective

To provide a molecular-level description of proto-biological processes and to explain phenomena occurring at interfaces between water and the simple membranes that form the walls of protocells. These membranes, built of chain molecules composed of polar-head groups and nonpolar chains arranged as bilayers, play a crucial role in promoting the organization of proto-biological organic material.

## Approach

We will simulate the behavior of the atoms in the system by molecular dynamics (numerical integration of Newton's equations of motion). The results are used to compute the thermal and transport properties of the system, which can be compared directly with experimental results. In addition, the molecular dynamics results provide a detailed and accurate microscopic description of the system that is often not available experimentally.

## Accomplishment Description

Molecular dynamics simulations of the interface between a membrane and water have been performed. The atomic-level structure of the bilayer has been examined, and is in qualitative agreement with x-ray and neutron-scattering data from related bilayers. The structure and fluidity of the membrane have been

characterized at the microscopic level, and the membrane interior was found to be disordered. The orientation of water molecules at the water–membrane interface and the penetration of water into the membrane has been analyzed. The electrostatic surface potential across the interface has been calculated. Simulations require about 10 megawords of memory and at least 200 Cray Y-MP hours to obtain a sufficiently long trajectory. Subsequent data analysis requires 50 megawords of memory, but only moderate Cray Y-MP time.

## Significance

The preferential orientation of water near the water–membrane interface and the electrostatic potential across the interface determine the orientations of solute molecules at the surface and influence their transport across membranes. The preferential orientations of solute molecules at the interface can enhance reaction rates, thereby serving as a catalyst for the synthesis of new molecules in the proto-biological environment.

## Future Plans

We will continue our studies of water–membrane interfaces, and will investigate interface chemical reactions and the transport of ions and small molecules across membranes.

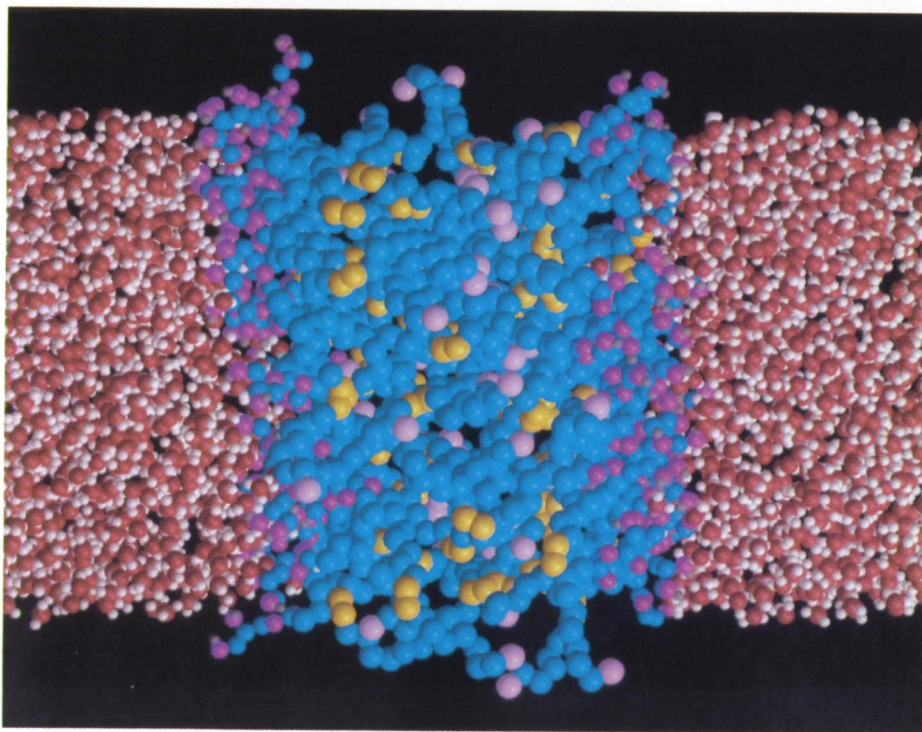

*Membrane bilayer between two lamellae of water. Polar-head groups of chain molecules (magenta) are located close to the interface. The terminal groups of the tails (pink) and C=C double bonds in the middle of the tails (yellow) are distributed throughout the membrane interior indicating the high fluidity of the membrane. The remaining tail groups are in blue. The ragged appearance of the figure edges is because only complete molecules are displayed, highlighting the degree of bilayer disorder.*

# Supersonic Boundary-Layer Transition on a Cone at Incidence

M. R. Malik, Principal Investigator  
Co-Investigator: P. Balakumar  
High Technology Corporation/NASA Langley Research Center

## Research Objective

To study the stability and boundary-layer transition in supersonic flow past a sharp cone at incidence and compare the results with experimental data.

## Approach

The flow field around the cone is decomposed into mean and perturbation parts. The mean flow was computed using the thin-layer Navier–Stokes code, TLNS3D. Calculations were performed for a  $97 \times 129 \times 49$  grid and were repeated for  $97 \times 257 \times 49$  grid to check convergence. The highly refined grid normal to the cone surface was needed for boundary-layer stability analysis. This flow is unstable to the first-mode and cross-flow instability. The amplification of these disturbances is correlated with the onset of transition by way of the  $e^N$  method.

## Accomplishment Description

Calculations were performed for a Mach 3.5 flow past a 5 degree semi-vertex cone at 2 degrees incidence. Even this small angle of attack introduces strong inflectional profiles along the leeward

line of symmetry. Compressible linear stability was studied for this flow and the  $e^N$  method was used to estimate transition onset. The accompanying figure shows the computed N-factor traces up to  $N = 10$ . The computed transition location moves upstream with the azimuthal angle going from the windward line of symmetry to the leeward line of symmetry. This is in qualitative agreement with the experiment performed in the NASA Langley Mach 3.5 tunnel. The stream movement of transition is due to the increased cross flow away from the windward line of symmetry.

## Significance

Transition in a fully three-dimensional supersonic boundary layer has been studied and compared with experiments.

## Future Plans

Calculations will be made for higher Mach numbers and the reasons for some discrepancies near the leeward line of symmetry will be investigated.

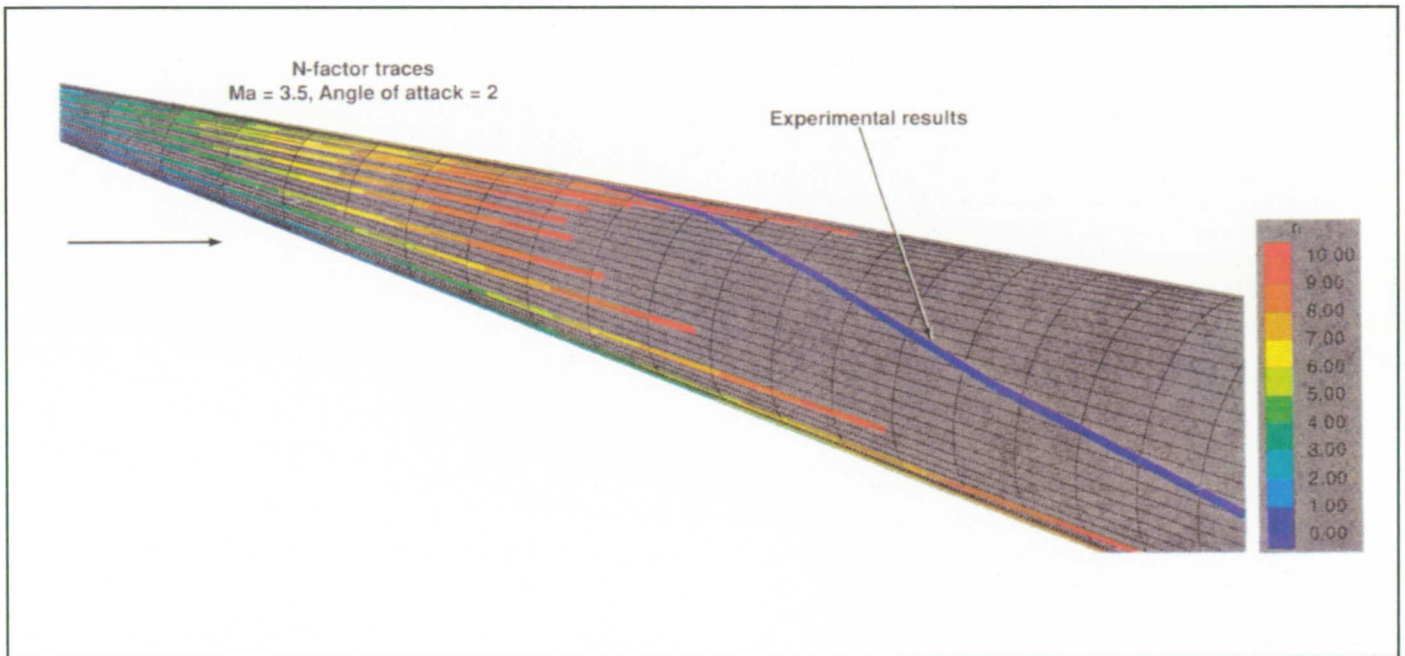

*N-factor computations for a cone at 2 degrees incidence and a comparison with the experiment.*

# Compressible Boundary-Layer Transition

M. R. Malik, Principal Investigator

Co-Investigator: C. L. Chang

High Technology Corporation/NASA Langley Research Center

## Research Objective

To study and understand the mechanisms involved in compressible boundary-layer transition and to provide a capability for boundary-layer transition prediction in both "quiet" and "disturbed" environments.

## Approach

The evolution of disturbances in compressible boundary layers is governed by partial differential equations (PDEs) which can be derived from the complete Navier-Stokes equations. The original PDEs are reduced to a set of parabolized stability equations (PSEs) which are parabolic along the dominant flow directions so that the solution can be obtained by single-sweep marching. Both nonparallel and nonlinear effects of growing boundary layers are studied up to the transition stage using the PSE approach. The computational time required is an order of magnitude less than that for direct numerical simulation.

## Accomplishment Description

Linear PSE calculations are performed for a Mach 1.6 flat-plate boundary layer. For the linear case shown in the accompanying figure, the growth rates computed by PSE agree quite well with those computed using the multiple-scale approach. For comparison, quasi-parallel results are also shown. The results indicate that nonparallel effects are more important for oblique waves ( $\psi = 50$  degree) than for two-dimensional waves ( $\psi = 0$  degree). Nonlinear PSE calculations are performed for the same Mach 1.6 boundary layer. Three-dimensional waves are the most amplified modes for supersonic boundary layers. A viable route to transition consists of two oblique primary waves interacting with each other. Our PSE results show that the initial amplitude required for oblique breakdown to occur is significantly lower when compared to that for the secondary mechanisms, which are dominant in incompressible flows. The figure shows the oblique breakdown process for three amplitudes at the given frequency. Transition location is clearly indicated by the rise of wall shear.

## Significance

The PSE method can be used to study the nonparallel and nonlinear evolutions to disturbances in compressible boundary layers from the linear stage to transition. Coupled with receptivity phenomena (the initiation of disturbances in the boundary layer), this approach offers a computationally viable means for studying and predicting the complex and intricate phenomenon of compressible boundary-layer transition.

## Future Plans

We will develop an axisymmetric version of the code to be used for transition studies in conical flows and studies at hypersonic Mach numbers.

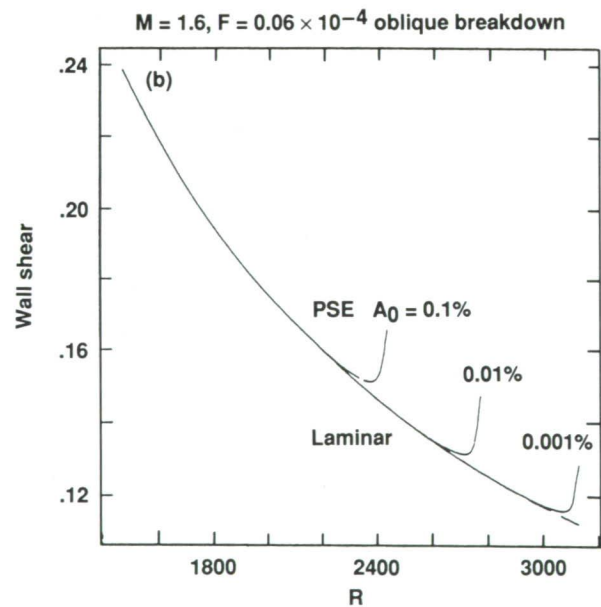
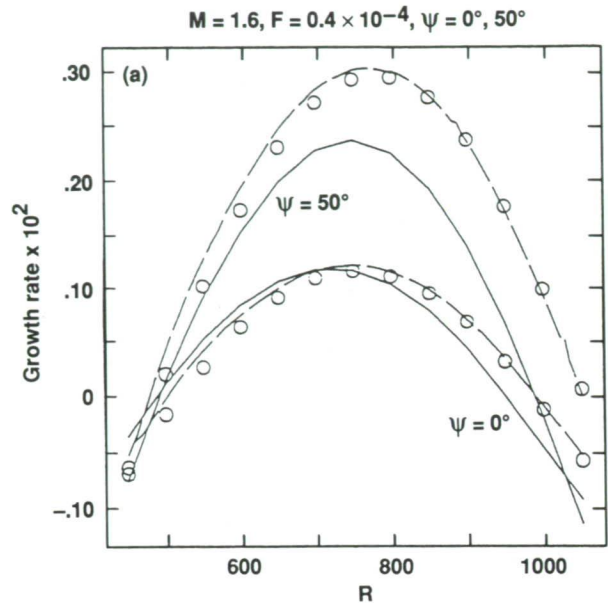

Evolution of linear and nonlinear disturbances in Mach 1.6 boundary-layer flow at the given nondimensional frequency ( $R = \sqrt{Re_x}$ ). (a) Linear analysis; parallel (solid line), nonparallel PSE (dashed line), and multiple-scale approach (symbols). (b) Nonlinear analysis; wall shear versus Reynolds numbers for oblique-wave breakdown procedures with three different initial amplitudes.

# Turbulence in Compressible Fluids

Nagi N. Mansour, Principal Investigator  
Co-Investigator: Gary N. Coleman  
NASA Ames Research Center

## Research Objective

To create a data base for compressible turbulent flows and to improve the accuracy of compressible turbulence models.

## Approach

Direct numerical simulations (DNS) of homogeneous compressible turbulence subjected to bulk compressions are generated, resolving all of the relevant scales so that no subgrid scale closure is required. The DNS results are used to test and guide improvements to models of compressible turbulence.

## Accomplishment Description

Flow fields and one-point statistics were obtained for various turbulent states and compression histories; a typical run required 20 Cray Y-MP hours and 2 megawords of memory. The manner in which the simulation data were used for model development is shown in the accompanying figure by the case of rapid isotropic (spherical) compression when the turbulent velocities are much smaller than the mean sound speed. Simulation results and linear theory were used to improve the two-equation model so that it correctly predicts the flow history. Comparisons of the rates of dissipation of turbulent kinetic energy given by the standard two-equation model, the simulation data, and the improved two-equation model are shown in the figure. We find that changes in the fluid viscosity, caused by the temperature increase induced by the compression, must be included in the turbulence model equations to correctly predict the development of the turbulence.

## Significance

Models of the turbulence in compressible fluids can help predict astrophysical phenomena, and help in the design of internal combustion engines, hypersonic flight vehicles, and supersonic combustors. Unfortunately, the accuracy of the turbulence models is, at times, less than acceptable. By adjusting the models so that they are correct for idealized flows, the models will be more accurate when applied to more general flows.

## Future Plans

We will continue model testing by considering new combinations of compression histories and flow parameters and attempt to extend the accuracy range of the models.

## Publications

1. Coleman, G. N. and Mansour, N. N. "Modeling the Rapid Spherical Compression of Isotropic Turbulence." *Physics of Fluids A*, 3, no. 9 (Sept. 1991): 2255–2259.
2. Coleman, G. N. and Mansour, N. N. "Simulation and Modeling of Homogeneous Compressible Turbulence under Isotropic Mean Compression." Presented at the Eighth Turbulent Shear Flows Conference, Munich, GE, Sept. 1991.
3. Mansour, N. N. and Wray A. A. "Direct Numerical Simulation Data: A Tool for Turbulence Modeling." Presented at the Fourth International Symposium on Computational Fluid Dynamics, Davis, CA, Sept. 1991.

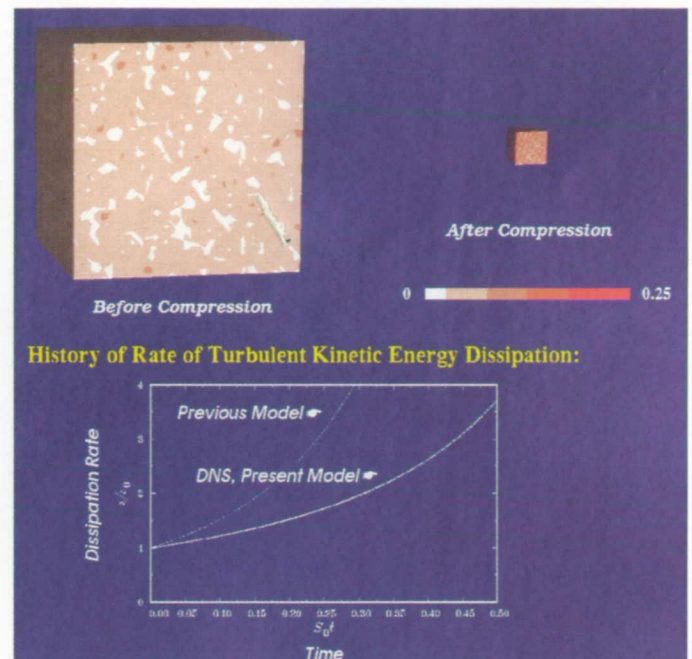

Comparisons of the rates of dissipation of turbulent kinetic energy given by the standard two-equation model, the simulation data, and the improved two-equation model.

# Flow-Field Calculations using Unstructured Grids

David L. Marcum, Principal Investigator

Co-Investigators: Ramesh K. Agarwal and David W. Halt

Mississippi State University/McDonnell Douglas Research Laboratories

## Research Objective

To develop a computational capability using adaptive unstructured grids to predict unsteady store separation and related flow fields.

## Approach

The Reynolds-averaged Navier–Stokes equations are solved on an unstructured grid of tetrahedral elements. Space discretization is obtained from a Galerkin-weighted residual approximation. Time discretization uses either an explicit two-step Lax–Wendroff scheme, or an explicit multistage Runge–Kutta scheme. Boundary conditions are implemented using a method-of-characteristics based procedure. Turbulence effects can be modeled using a two-equation  $k$ - $\epsilon$  turbulence model. An advancing-front grid-generation scheme is used to generate solution-adaptive unstructured grids. The overall solution procedure has been initially validated for two- and three-dimensional inviscid and viscous flow fields.

## Accomplishment Description

The finite-element Navier–Stokes code, MDFENS, was modified to include the capability to calculate unsteady flow fields and store trajectories for cases with multi-body separation. For these cases, the unstructured grid changes in time. Surrounding each body is a region of elements that move rigidly with the body. Between bodies, elements deform when there is relative motion. Periodically, a new solution-adaptive grid is generated to minimize distortion of deforming elements. An unsteady inviscid calculation of a hypersonic vehicle dispensing a store was performed to evaluate the overall procedure. For this configuration, the dispensing vehicle is considerably larger than the

separating store and the flow field near the store can be computed separately. The steady flow field about the dispensing vehicle was first calculated without the store. This flow field was used to determine inflow conditions for time dependent calculation of the flow field near the separating store. The store trajectory was computed from a time integration of the aerodynamic forces acting on the separating store. A typical calculation with 400,000 elements requires 14 megawords of memory and 0.5–1 Cray Y-MP hour per grid remeshing cycle. A complete trajectory can require 40 Cray Y-MP hours.

## Significance

Predicting unsteady flow fields with multi-body separation is important to many military and aerospace programs.

## Future Plans

Calculations of flow fields about vehicles with a separating store will be validated with experimental data. The solution-adaptive grid-generation procedure with a local remeshing capability will be incorporated within the flow solver. Development of techniques to improve the computational efficiency of the present procedure for unsteady viscous-flow calculations will continue.

## Publications

1. Marcum, D. L. and Agarwal, R. K. "Finite-Element Navier–Stokes Solver for Unstructured Grids." *AIAA Journal* 30, no. 3 (1992): 648–654.
2. Marcum, D. L. and Agarwal, R. K. "A Three-Dimensional Finite-Element Navier–Stokes Solver with  $k$ - $\epsilon$  Turbulence Model for Unstructured Grids." AIAA Paper 90-1652, 1990.

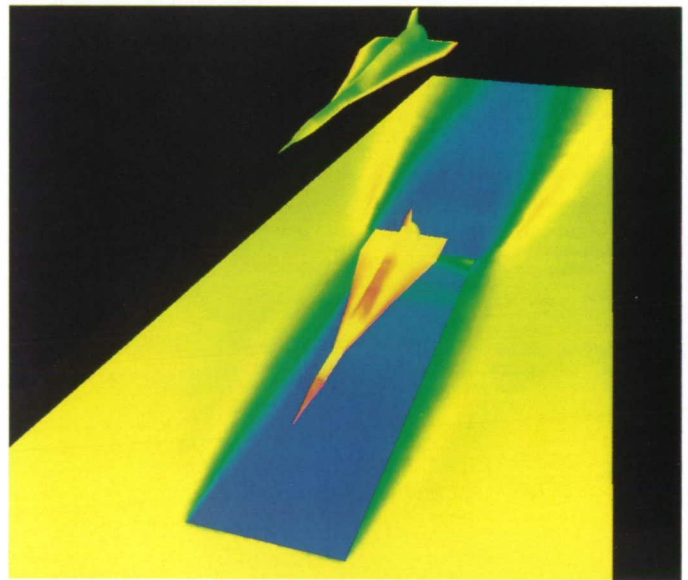
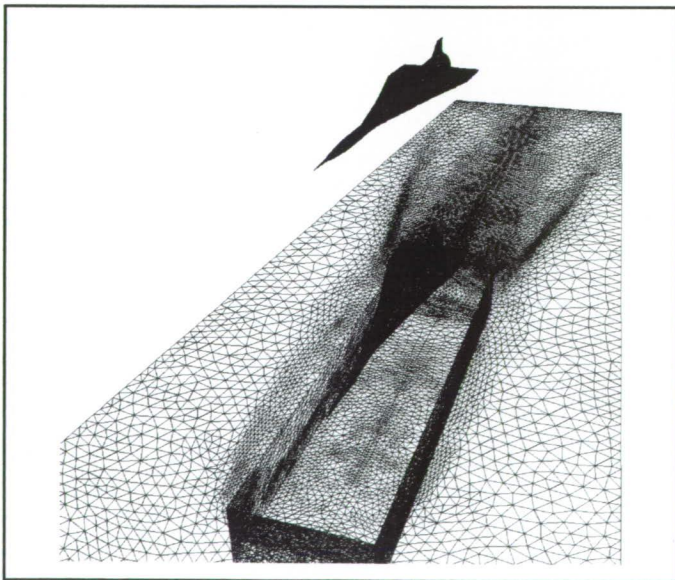

*Adapted surface-mesh and instantaneous-density contours for unsteady hypersonic flow about a separating store.*

# Space Shuttle Flow Field

Fred W. Martin, Jr., Principal Investigator

Co-Investigators: Pieter Buning, Steve Labbe, Ray Gomez, Jeff Slotnick, Steve Parks, and Max Kandula

NASA Johnson Space Center/NASA Ames Research Center

## Research Objective

To improve the numerical modeling of the Space Shuttle launch-vehicle-ascent aerodynamic environment by adding multiple-species plume capability to the flow solver.

## Approach

The OVERFLOW-Chimera scheme is used to obtain flow fields about the Space Shuttle launch vehicle in Mach number range 0.6 to 4.5, with particular emphasis in the transonic range. The accuracy of the redesigned solid rocket motor (RSRM) and Space Shuttle main engine (SSME) plume simulation is improved by adding the capability to convect multiple gas species.

## Accomplishment Description

The JANNAF plume programs RAMP and SPF were used to define the RSRM nozzle exit conditions and plume properties for a Space Shuttle trajectory condition at Mach 1.25. These results are axisymmetric and do not include the influence of the Space Shuttle launch vehicle, thus they serve as the baseline plume definition for an undisturbed plume. The OVERFLOW program was modified to include high-temperature gas effects through the solution of a species convection equation for each flow-field gas. Gases are modeled as chemically frozen and are characterized as thermally perfect and calorically imperfect. The specific heat ratio,  $\gamma$ , at each mesh point is mass averaged from the concentra-

tions of constituent gases in the flow. In the loosely coupled approach,  $\gamma$  is used in the global-equation set to incorporate real-gas effects. The internal RSRM nozzle flow field was obtained from the RAMP code. The nozzle exit solution was then used as the plume start-line boundary condition in OVERFLOW. Downstream from the nozzle, computed external plume flow-field properties, including shear layer development and shock structure, were compared to SPF results.

## Significance

The Space Shuttle launch-vehicle aerodynamic loads are strongly influenced by the RSRM and SSME plume/flow-field interactions. In particular, the RSRM plume acts to increase the pressure on the external tank base, and the Orbiter lower-aft fuselage/wing area. The correct modeling of these effects is instrumental in obtaining accurate simulations of the Space Shuttle ascent aerodynamic loads.

## Future Plans

The improved plume-model capability will be evaluated by completing a three-dimensional calculation of the Space Shuttle with RSRM plumes with and without real-gas effects. Comparisons of hot-gas plume wind tunnel data and flight measurements from Columbia will be used to check the accuracy of the new plume model.

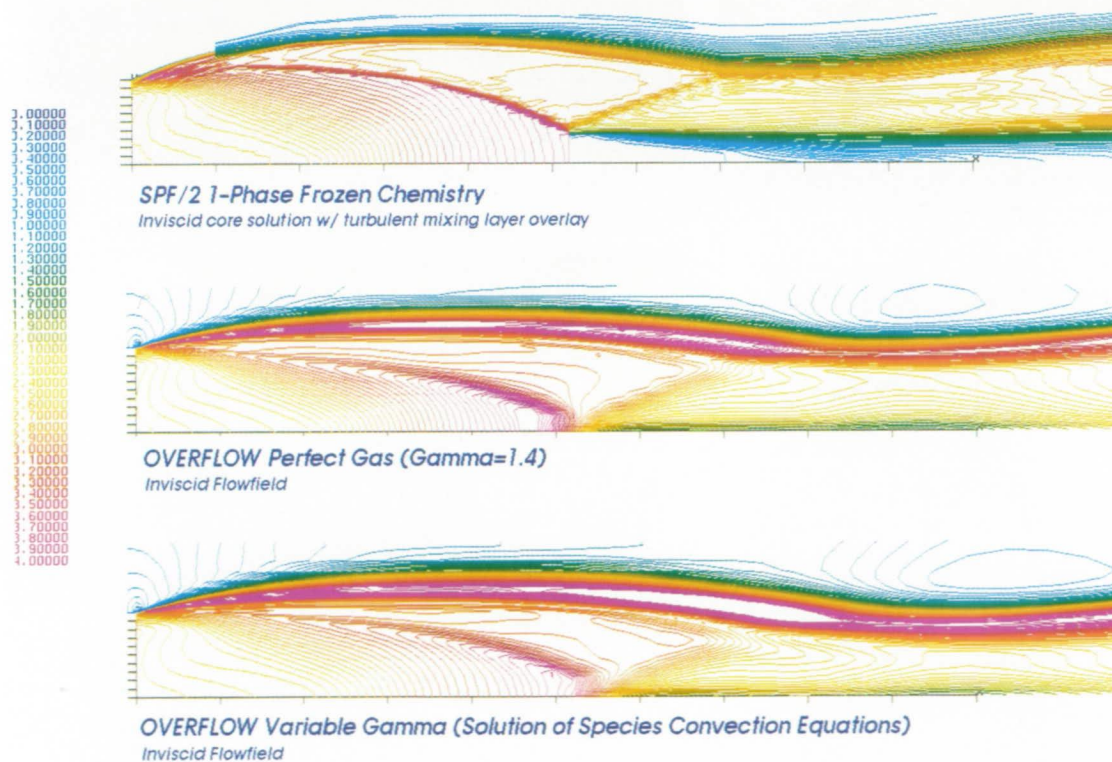

Comparison of axisymmetric redesigned solid-rocket-motor solutions.

# Multigrid Solution of the Euler Equations

Dimitri J. Mavriplis, Principal Investigator  
ICASE/NASA Langley Research Center

## Research Objective

To develop an accurate and efficient method for computing steady-state compressible flow about complex three-dimensional configurations.

## Approach

The steady-state three-dimensional Euler equations are solved on an unstructured tetrahedral mesh by a Galerkin finite-element scheme. The flow variables are stored at the vertices of the mesh, and an edge-based data structure is employed to minimize memory requirements. An unstructured multigrid technique is employed to accelerate convergence to steady state. This procedure operates on a sequence of non-nested coarse and fine meshes and the patterns for interpolation between the various meshes of the sequence are determined in a preprocessing step using an efficient search algorithm. For large applications, which require a significant portion of the Cray Y-MP main memory, a multitasked version of the solver has been developed.

## Accomplishment Description

The present methodology is capable of providing accurate and efficient solutions for steady-state inviscid three-dimensional flows using very fine meshes. The accompanying figure illustrates the computation of transonic flow over a wing-body-nacelle configuration. A multigrid sequence of four meshes has been employed. The finest mesh of the sequence contains 804,000 vertices and 4.5 million cells. The final solution was obtained in 100 multigrid cycles on the finest grid, during which the residuals were reduced by six orders of magnitude. This run required 96 megawords of memory and 16 Cray Y-MP minutes running in a dedicated mode on all eight processors. A computational rate of 750 MFLOPS was achieved using eight processors, which is 7.5 times faster than the single-processor.

## Significance

The ability to accurately and efficiently predict compressible flows over complex three-dimensional geometries is important to the aircraft industry. The simultaneous use of multitasking and an efficient multigrid strategy enable the solution of large, complex problems in a matter of minutes.

## Future Plans

Future work will center on the inclusion of more adequate surface-modeling and grid-generation techniques, as well as the extension of the present work to viscous turbulent-flow cases in three dimensions, which will require the implementation of a multiple-field-equation turbulence model.

## Publication

Mavriplis, D. J. "Unstructured Multigrid for the Three-Dimensional Euler Equations." AIAA Paper 91-1549, *10th AIAA Computational Fluid Dynamics Conference*. Honolulu, HI, June 1991.

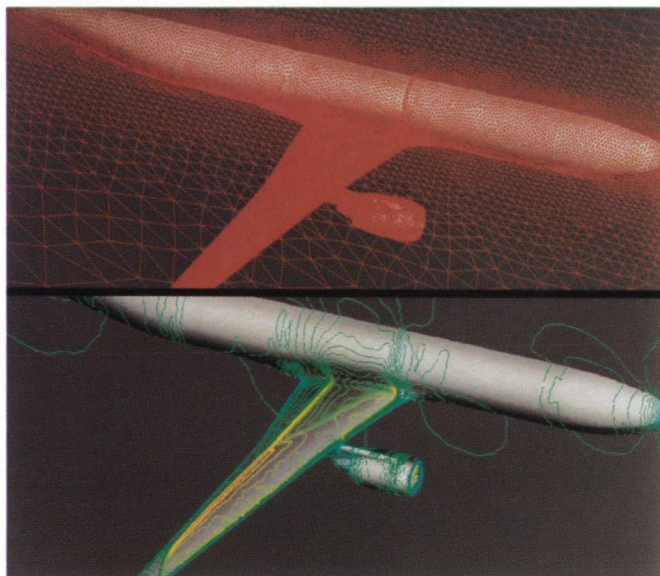

*Computation of transonic flow over a wing-body-nacelle configuration.*

# High Mach-Number Mixing in a Shock Tunnel Environment

Charles R. McClinton, Principal Investigator

Co-Investigator: Robert D. Bittner

NASA Langley Research Center/Analytical Services and Materials, Inc.

## Research Objective

To provide pre- and posttest computational fluid dynamics (CFD) support to aid in the understanding of the first series of high-speed scramjet-combustor tests using the Ames 16-Inch Shock Tunnel. In the process, more confidence in the ability of CFD to model complex hypersonic-injection flow fields will be developed.

## Approach

The SPARK codes were used to model the flow field in this high Mach-number environment. A set of three-dimensional elliptic and parabolic solvers has been extensively calibrated and applied to scramjet-combustor problems. The model tested in the Ames 16-Inch Shock Tunnel was a wedge angled at 11 degrees to a Mach 5 free stream with hydrogen injected at 30 degrees from the model surface. Turbulence was modeled using a standard Baldwin-Lomax algebraic approach. Both mixing and reacting cases were solved. A seven-species, seven-reaction mechanism was used to model the kinetics in the problem. CFD results were compared with all available data from the tests including wall pressures, shadowgraphs, and finite-fringe interferograms.

## Accomplishment Description

The computational work has been completed for both mixing and reacting analyses of the wedge-model tests. The results compared favorably with the available test data. The accompa-

nying figure shows a comparison of CFD laterally averaged density versus a finite-fringe interferogram. This comparison shows that the basic flow physics, such as the wedge leading-edge shock, the injection bow shock, and the fuel-mixing layer, qualitatively agree. The fuel penetration height is indicated on the CFD contours and the interferogram. This agreement verifies facility nominal-operating conditions. In addition, the confidence in the ability of CFD to accurately predict scramjet-combustor flow fields has been increased in terms of surface loads and overall flow physics. A typical case requires 20 megawords of memory and 2-4 Cray-2 hours.

## Significance

These studies are being used in conjunction with other high-enthalpy experimental programs in an effort to provide a much needed Mach 10-16 data base for validation of hypersonic scramjet-combustor performance. Furthermore, CFD enables a detailed examination of the flow field, including an ability to quantify the mixing, combustion, and losses in a scramjet combustor.

## Future Plans

Future tests are planned with more complex geometries and higher total reservoir pressures resulting in a test more representative of the hypersonic environment. An evaluation of this combustor will be analyzed with SPARK. The CFD results will be used to assess the combustor efficiency and flow losses.

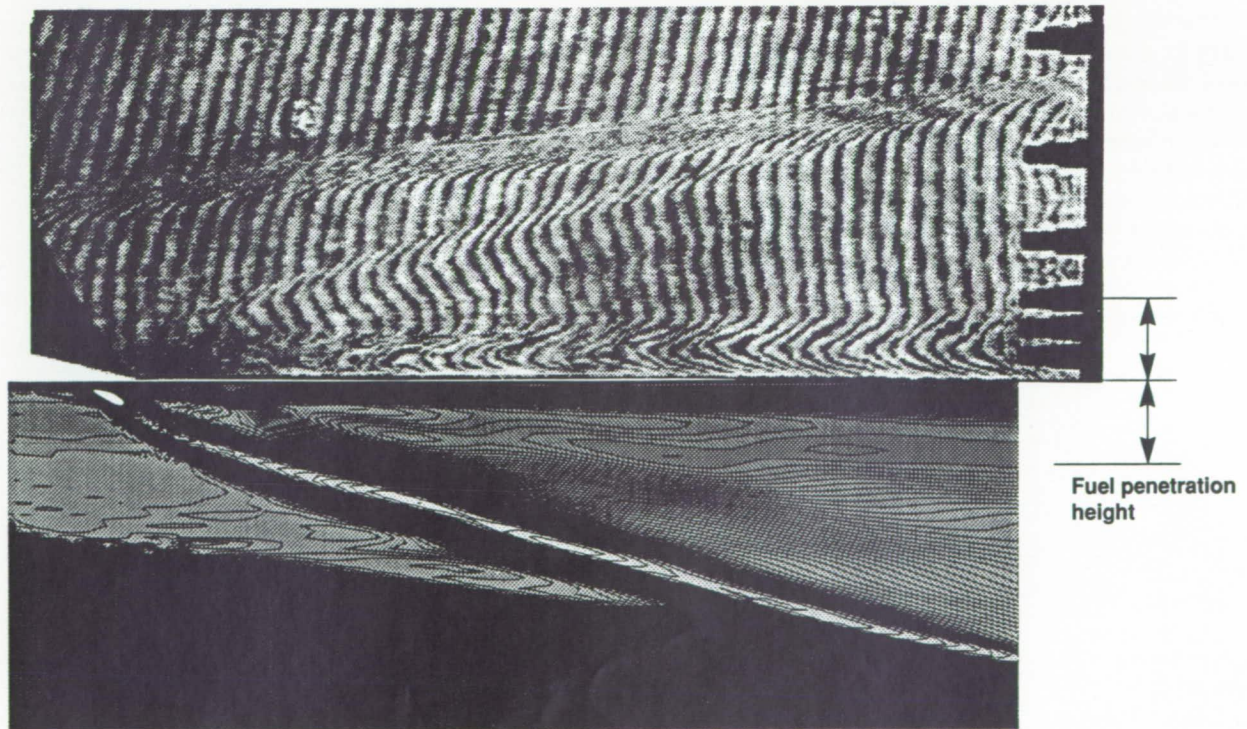

Comparison of computational fluid dynamics laterally averaged density contours with a finite-fringe interferogram.

# National Aero-Space Plane Configuration Trade Studies

Charles R. McClinton, Principal Investigator

Co-Investigators: Arthur D. Dilley and Richard W. Hawkins

NASA Langley Research Center/Analytical Services and Materials, Inc.

## Research Objective

To perform trade studies for the National Aero-Space Plane (NASP) program using computational fluid dynamics (CFD) codes. These studies involve the airframe, propulsion system, and airframe-propulsion system integration. The results will optimize the overall NASP design and individual elements of the vehicle.

## Approach

We used calibrated CFD codes to analyze external and internal flow fields for NASP vehicles and vehicle components. The codes are being coupled with linear-stability codes to study boundary-layer transition on the NASP vehicle. This is a new area of application for current CFD codes; insights into computational requirements for mean-flow and linear-stability calculations are being gained.

## Accomplishment Description

Using CFD, we analyzed the forebody of an alternative NASP configuration at several flow conditions. The integrated-mass capture and other flow-field data were used to determine the viability of the alternative NASP configuration. We performed a parametric study on a hypersonic-flight vehicle to optimize the viability of several experiments located on the flare portion of the vehicle. The parametric study considered several flare lengths and analyzed the flow field immediately ahead of the experiments. The accompanying figure shows the flow-field structure including the bow-shock/ramp-shock intersection, the resulting slip line, the boundary-layer edge, and the inlet experiment location. A baseline vehicle geometry was developed using the results from this parametric study. We initiated mean-flow calculations for linear-stability code analysis. These calculations indicated a need for unusually restrictive computational requirements when performing mean-flow calculations. These computational requirements are from the linear-stability code requirement for smooth first and second derivatives of flow-field quantities. The net result of all these requirements is a highly accurate resolution throughout the boundary layer. An average job requires 15 megawords of memory and 2-4 Cray-2 hours.

## Significance

We can apply current CFD codes to solve design problems associated with NASP and related hypersonic-flight vehicles.

## Future Plans

We will continue to perform trade studies for the NASP program and develop the capability to provide accurate mean-flow computations for linear-stability analysis.

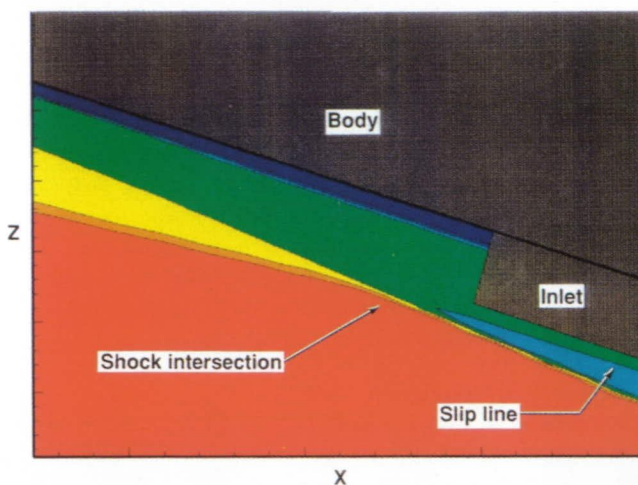

Computational fluid dynamics applications for vehicle design. Mach number contours on a biconic configuration at Mach 15; red = high values, blue = low values. The inlet is located where the flow is completely turbulent and sized by the location of the slip line.

# Scramjet Inlet Interaction

Charles R. McClinton, Principal Investigator  
Co-Investigators: Thomas N. Jentink and Arthur D. Dilley  
NASA Langley Research Center/Analytical Services and Materials, Inc.

## Research Objective

To perform an inlet-unstart computational study on a full-scale, two-dimensional inlet (no sidewall compression) with short, set-back splitter plates to determine whether the unstarted module will cause unstart in neighboring modules.

## Approach

The study was performed using the computational fluid dynamics code CFL3D. First, we performed two-dimensional, turbulent calculations of the full-scale configuration, starting with the wedge-type forebody and extending through the inlet to the module's exit. This solution was used to study several techniques for causing the inlet to unstart. The localized-heat addition was chosen to allow adaptation to the changing mass flow rate during the unstart process. Next, we obtained a three-dimensional steady state, started a solution for a half module, and began the unstart sequence by unstarting an adjacent half-module. Additional blocks were added to the calculation as the unstart progressed.

## Accomplishment Description

The problem had 1.5 modules comprised of 15 blocks and approximately 1.3 million points. The unstart shock moved 10 inches upstream from the splitter-plate leading edge, then slowed its upstream movement as it spilled approximately 25% of its mass into the started module. The flow in the started module was highly distorted and had begun to spill a small amount of mass into what would have been another module had an additional block been added. At this point, it was determined that the module was unstarted and the computation was terminated. This study provided an excellent qualitative look at module-to-module interaction during inlet unstart. Approximately 450 Cray-2 hours (run in 4 to 6 hour segments) were used. Typical runs required about 55 megawords of memory. The accompanying figure shows a cowl-side view within the module region of both the started and the unstarted solutions. Pressure contours are shown, with blue denoting the lowest pressure, and red the highest pressure.

## Significance

Inlet unstart is an important issue in the design of scramjet propulsion for the National Aero-Space Plane (NASP). The performance of each inlet design depends on the types of interactions occurring between the inlet modules. If one module unstarts, it has a large effect on inlet and aerodynamic loads and may unstart neighboring modules. This study provides a picture of the unstart process of this inlet design and, in conjunction with experimental studies, will result in a better understanding of inlet unstart in scramjet propulsion systems.

## Future Plans

This work has been completed and the results have been reported to the appropriate NASP program participants.

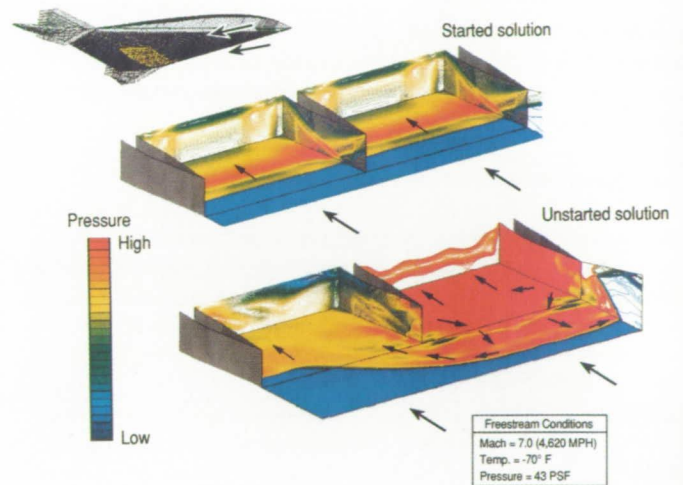

*Detail of a scramjet engine unstart.*

# Scramjet Engine Design Optimization

Charles R. McClinton, Principal Investigator

Co-Investigators: Pradeep S. Kamath and Marlon Mao

NASA Langley Research Center/Analytical Services and Materials, Inc.

## Research Objective

To develop an understanding of the high-speed (Mach > 8) scramjet-combustor performance related to specific combustor design constraints in order to design effective high-speed scramjet combustors and develop a consistent parametric numerical database for potential high-speed scramjet combustor designs.

## Approach

We will develop a numerical data base using the previously calibrated SHIP three-dimensional parabolized Navier–Stokes design code. The test matrix is generated using an advanced test-design process. First, important design variables and engine performance response parameters are determined. A statistical test-design method is used to minimize the number of solutions required to represent the important design degrees of freedom for the full-factorial parametric design space. Response parameter results from the numerically generated data base are evaluated to determine trends and to develop analytical models. The analytical models are used to select better configurations for additional in-depth study.

## Accomplishment Description

We completed about 150 large-scale scramjet combustor flow-field solutions for two of the three fuel-injector classes being studied. The solutions represent about 5% of the full-factorial test matrix for the two classes. Design parameters included injector/ combustor geometric issues, flight Mach number, and fuel-equivalence ratio. The test matrix provided for linear, nonlinear, and interaction terms in regression fits of the numerical data base. The accompanying figure illustrates a typical combustor solution, including fuel concentration contours on four flow-field cross sections and heat flux on one wall. The resulting numerical data bases were used to generate analytical models for fuel-mixing efficiency, fuel-injector drag, combustor-entropy rise, heat load, peak-heat flux, shear force, and effectiveness. Also shown is a regression fit for combustor effectiveness for the Mach 18 solutions. These models compare favorably with existing experimental results and Navier–Stokes solutions. A typical run requires 1 megaword of memory and 1–4 Cray-2 hours.

## Significance

The first numerical-design data base for high-speed scramjet combustors was developed. This data base enhances the understanding of scramjet performance issues such as trades between combustor injector design and mixing/combustion performance, combustion efficiency and thrust produced, and mixing and combustor heat load. The analytical models provide a method of engine design optimization, which has already produced a significant increase in combustor performance for the National Aero-Space Plane designs.

## Future Plans

We will complete our evaluation and verification of the numerical data base with Navier–Stokes solutions using the SPARK and General Aerodynamic Simulation Program codes. We will select a single-combustor performance-response parameter, extend the range of parametric variables for configurations on a boundary test matrix, and recommend direction for additional parametric studies.

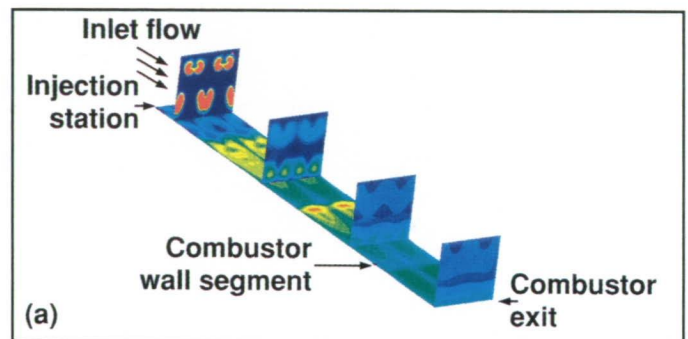

A typical scramjet-combustor solution at Mach 15 with heat flux on a wall. The fuel-concentration planes show characteristic kidney shapes caused by the ramp-induced vortices; red = high values, blue = low values.

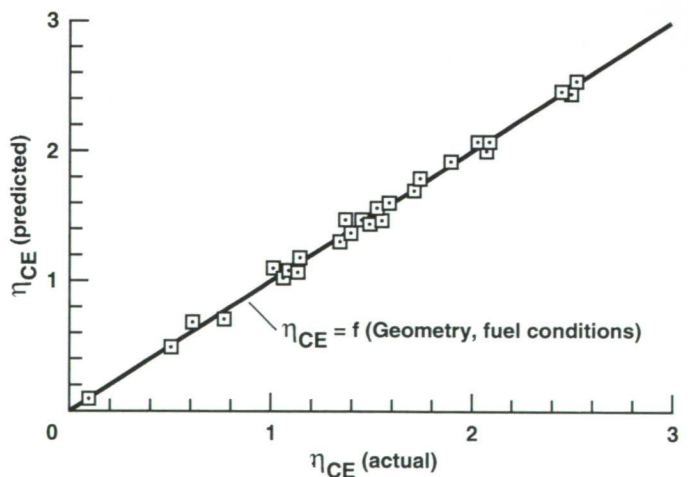

Combustor effectiveness ( $\eta_{CE}$ ) regression at Mach 18.

# Aerodynamics and Acoustics of Rotorcraft

W. J. McCroskey, Principal Investigator

Co-Investigators: J. D. Baeder, V. Raghavan, G. R. Srinivasan, and S. K. Stanaway

U.S. Army Aeroflightdynamics Directorate, AVSCOM/NASA Ames Research Center

## Research Objective

To develop and validate accurate, user-oriented, viscous, computational fluid dynamics codes (with inviscid options) for three-dimensional unsteady aerodynamic flows about arbitrary rotorcraft configurations. The ability to calculate complex vortical wakes, shock waves, rotor-body interactions, and the associated acoustic field will be included.

## Approach

Advanced three-dimensional unsteady multizone implicit Euler and Navier-Stokes codes are used to simulate rotorcraft aerodynamics and acoustics under new flight conditions that have not previously been treated satisfactorily. Accuracy and stability are achieved for rotor blades by using the transonic unsteady-rotor Navier-Stokes code, which features full upwinding, enhanced accuracy, and high computational efficiency. Rotorcraft airframes are treated using the OVERFLOW code with Chimera-overlapped zonal-grid technology, which is well-suited to moving interfaces between fixed and rotating grids. In addition, special solution-adaptive grid-clustering and wave-fitting techniques are used to capture low-level radiating acoustic waves and trailing tip vortices.

## Accomplishment Description

Important results were obtained for high-speed impulsive noise. The hover results form a large numerical data base which is being used by theoretical acousticians to verify the soundness of the acoustic analogy approach. Results have also been obtained for the V-22 Osprey fuselage alone and the wing-body combination at three angles of attack using the OVERFLOW Navier-Stokes code. The results were compared with experimental airloads and potential-flow calculations. The accompanying figure shows the color-coded surface pressures and flow particle traces at 10 degrees. The Navier-Stokes results showed separation on the lower rear of the fuselage and at the sponson-fuselage junction. The calculated lift for the fuselage-wing combination agrees with the experimental value to within about 10%. These results will be refined during the next year, and the nacelles, rotors, and empennage will be added.

## Significance

The ability to accurately simulate the aerodynamics and acoustics of rotorcraft will allow quieter vehicles to be designed at lower cost and with less risk. Analysis of the flow separation on the Osprey V-22 airframe will permit drag-reduction improvements to be investigated and implemented at a fraction of the cost of wind tunnel studies.

## Future Plans

We will develop more accurate and efficient simulations of rotorcraft aerodynamics and acoustics, particularly on blade-vortex interaction noise and rotor-body aerodynamic interference on tilt-rotor aircraft.

## Publications

1. Baeder, J. D. "Euler Solutions to Nonlinear Acoustics of Non-Lifting Rotors in Forward Flight." *American Helicopter Society/Royal Aeronautical Society International Technical Specialists' Meeting*. Philadelphia, PA, Oct. 1991.
2. Srinivasan, G. R. and Baeder, J. D. "Recent Advances in Euler and Navier-Stokes Methods for Calculating Helicopter-Rotor Aerodynamics and Acoustics." *Fourth International Symposium on Computational Fluid Dynamics*. Davis, CA, Sept. 1991.

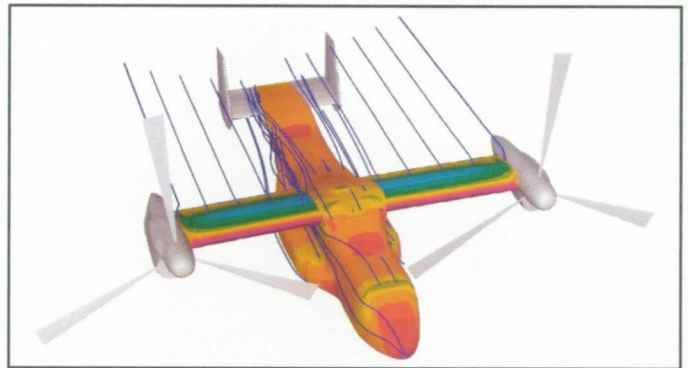

Color-coded surface pressure and particle traces on the Osprey V-22 wing-fuselage simulation in cruise; Mach = 0.2, Reynolds number =  $10^6$ ,  $\alpha = 10$  degrees.

# High-Performance Rotor-Blade Tips

W. J. McCroskey, Principal Investigator

Co-Investigators: E. P. N. Duque, V. Raghavan, G. R. Srinivasan, and R. C. Strawn

U.S. Army Aeroflightdynamics Directorate, AVSCOM/NASA Ames Research Center

## Research Objective

To compute the viscous three-dimensional unsteady flow field around an advanced helicopter rotor. Particular emphasis is placed on viscous transonic aerodynamics of high-performance rotor-blade tips and resolution of the vortical wake details of rotors in hover.

## Approach

The unsteady three-dimensional Euler/Reynolds-averaged Navier–Stokes equations are solved by structured- and unstructured-grid methods, either in blade-fixed or inertial reference systems. The codes are validated through detailed comparisons with experimental data.

## Accomplishment Description

The transonic unsteady-rotor Navier–Stokes (TURNS) structured-grid code was improved and applied to the flow fields of complex multibladed lifting rotors in hover. The results show good agreement with experimental data for surface pressures, thrust, power, and near-field vortex trajectory. However, the detailed structure of the vortex core is difficult to resolve with the single-block formulation. The first unstructured-grid rotor-blade solution was obtained with an explicit upwind Euler code with a locally refined grid. The upper section of the accompanying figure shows the grid at the boundary after two refinements in the wake; the lower section shows color-coded vorticity contours arising from the convected tip vortex. Excellent agreement with experimental airloads data was obtained, although further solution-adaptive grid refinement in the wake seems to be necessary.

## Significance

The TURNS code is efficient and robust for computing airloads on helicopter blades. The feasibility of locally refining the grid in the wake in order to improve the resolution of the vortical wake structure by means of a solution-adaptive unstructured-grid code was demonstrated for the first time.

## Future Plans

Chimera multiblock overlapped zonal-grid technology will be incorporated into the TURNS structured-grid code for improved wake computations and for rotor–body interactions. The solution-adaptive unstructured-grid code will be applied to acoustic-wave computations. It will be improved for tip-vortex simulations and extended to forward flight.

## Publications

1. Srinivasan, G. R.; Raghavan, V.; and Duque, E. P. N. "Flow-Field Analysis of Modern Helicopter Rotors by Navier–Stokes Method." *American Helicopter Society/Royal Aeronautical Society International Technical Specialists Meeting*. Philadelphia, PA, Oct. 1991.
2. Strawn, R. C. and Barth, T. J. "A Finite-Volume Euler Solver for Computing Rotary-Wing Aerodynamics on Unstructured Meshes." *American Helicopter Society 1992 Annual Forum*. Washington, DC, June 1992.

261,133 Nodes 1,448,336 Tetrahedra 24,434 Boundary faces

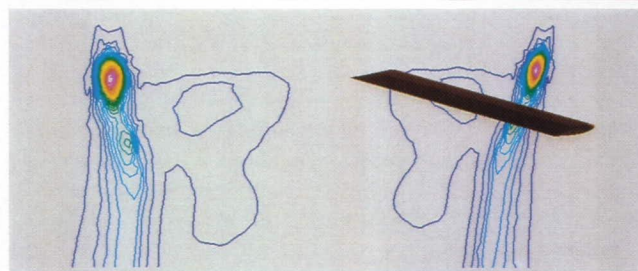
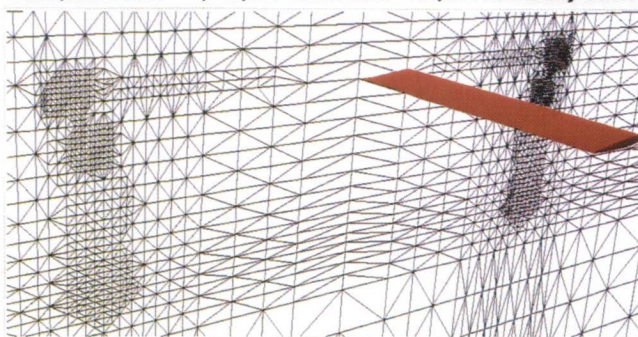

Grid and vorticity contours at the boundary of a hovering helicopter rotor blade; 261,133 nodes, 1,448,336 tetrahedra, and 23,434 boundary faces.

# Active Control of Ramjet Combustion Instability

Suresh Menon, Principal Investigator  
QUEST Integrated, Inc.

## Research Objective

To investigate techniques to control unstable combustion in ramjets using large-eddy simulations (LES). Numerical research is being conducted parallel to ongoing experimental studies.

## Approach

The unsteady compressible Navier–Stokes equations, together with a thin-flame model for premixed combustion, are solved using an explicit fourth-order-accurate finite-volume scheme. The turbulent-flame speed appears explicitly in the combustion model as a function of the laminar-flame speed and the subgrid-turbulence kinetic energy. A one-equation model for the subgrid-turbulence kinetic energy is used in the code.

## Accomplishment Description

The low-frequency, large-amplitude oscillation in the combustor is driven primarily by the inlet acoustic mode. However, in some cases a coupled convective–acoustic mode can also excite the instability. Results are in good agreement with experimental data. The spatial variation of the subgrid kinetic energy and the turbulent-flame speed is highly dependent on the presence of large vortical structures in the combustor. This is consistent with experimental observations of the large structures entraining the flame and wrinkling it, thereby increasing the local-flame speed. Secondary fuel-injection control strategies have been studied. When the controller is effective, the low-frequency oscillation is replaced by a high-frequency, low-amplitude oscillation. When the controller is only partially effective, the amplitude is reduced, but the frequency is unaffected. Similar to experimental observations, control of one frequency results in the excitation of other frequencies. Simulation of combustion instability required about 40 Cray-2 hours using a grid of  $320 \times 64$  and approximately 8 megawords of memory. Each simulation of active control required about 15 Cray-2 hours.

## Significance

The simulation provided detailed information on the behavior of unstable combustion in ramjet engines. The fully coupled flame and subgrid model can reproduce features observed in experimental configurations. Active control results are in good agreement with experimental observations and the LES results will be used to interpret experimental results.

## Future Plans

Active control using secondary fuel injection will be studied in more detail. More complex controllers for multiple frequencies will be investigated. The effects of flame curvature and local extinction will be incorporated to generalize the LES capability. Finally, fully three-dimensional LES will be done to investigate the importance of three-dimensional vortex stretching on the instability mechanism.

## Publications

1. Menon, S. "Active Combustion Control in a Ramjet using Large-Eddy Simulation." *Comb. Sci. and Tech.* 84 (1992): 51–79.
2. Menon, S. "A Numerical Study of Secondary Fuel-Injection Techniques for Active Control of Combustion Instability in Ramjets." AIAA Paper 92-0777, 30th Aerospace Sciences Meeting, Reno, NV, 1992.

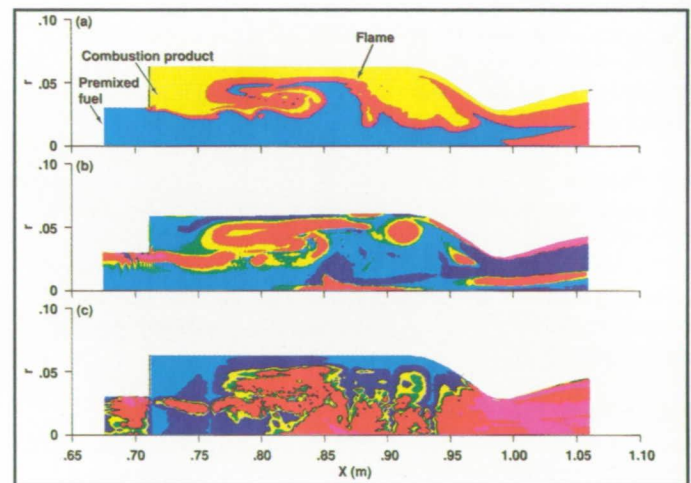

Combustion instability in a ramjet engine; (a) flame structure, (b) vortex structure, and (c) subgrid kinetic energy.

# Coupled Navier–Stokes Maxwell Analysis for Microwave Propulsion

Charles L. Merkle, Principal Investigator  
Co-Investigator: S. Venkateswaran  
Pennsylvania State University

## Research Objective

To model microwave plasmas in experimental configurations. Comparisons and parametric studies are being performed to establish the validity of the model and to understand experimental trends.

## Approach

Coupled solutions of Navier–Stokes equations for gas dynamics and Maxwell equations for microwaves are obtained by finite-difference approximation of the equations. The Navier–Stokes equations are preconditioned for efficient computation of the low-Mach-number flows, while the Maxwell equations are solved by an explicit time-accurate procedure.

## Accomplishment Description

Numerical computations have been performed for resonant cavity and waveguide configurations. For both cases, experimental conditions were duplicated and detailed comparisons of plasma temperature, coupling efficiency, and overall thermal efficiency were made to establish the accuracy of the computational results. Nearly 40 different cases were computed to perform detailed parameter surveys. Grid-resolution studies were carried out to verify solution accuracy.

## Significance

Computational results demonstrate that resonant-cavity plasmas show excellent stability and high coupling efficiencies (up to 99%) over a wide range of powers. Waveguide plasmas with a reflecting end wall also show good plasma stability, but the coupling efficiency drops almost linearly as incident power is increased.

## Future Plans

We will study the effect of asymmetries in the power coupling to the cavity, model realistic microwave-thruster configurations, and investigate size scale-up issues.

## Publications

1. Venkateswaran, S. and Merkle, C. L. "Numerical Investigation of Bluff-Body Stabilized Microwave Plasmas." AIAA 22nd Fluid Dynamics, Plasmadynamics, and Lasers Conference, Honolulu, HI, June 1991.
2. Venkateswaran, S. and Merkle, C. L. "Numerical Modeling of Waveguide-Heated Microwave Plasmas." Symposium of Multi-Disciplinary Applications of CFD, ASME Winter Annual Meeting, Atlanta, GA, Dec. 1991

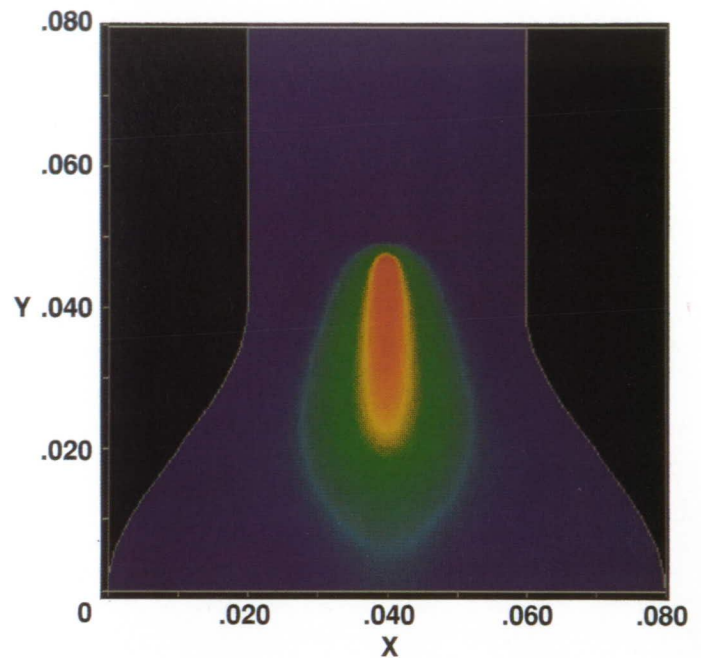

Bluff-body stabilized plasma in a quartz tube at power level = 1 kW.

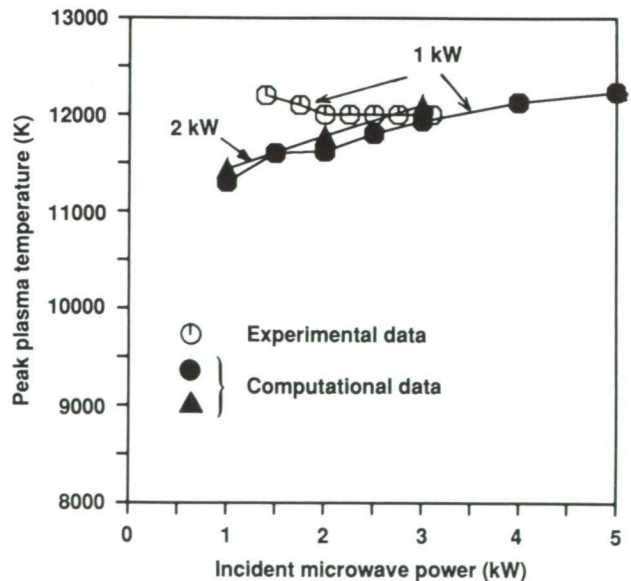

Peak plasma temperature versus incident microwave power for different incident power levels. Experimental data are included for comparison.

# Turbulent Flow Over Riblets

Parviz Moin, Principal Investigator  
Co-Investigators: John Kim and Haecheon Choi  
Stanford University/NASA Ames Research Center

## Research Objective

To study the mechanics of turbulent drag reduction by riblets. The results of this investigation could lead to the design of better riblet configurations leading to more drag reduction.

## Approach

Direct numerical simulations (DNS) are used to simulate turbulent flows over longitudinal riblets. A fully implicit finite-difference method is used to solve unsteady incompressible Navier–Stokes equations in a generalized coordinate system.

## Accomplishment Description

We have computed the flow in a channel with riblets on one wall and have considered four cases,  $S = 20$  and  $S = 40$ , where  $S$  is the spacing of the riblets in wall units, and ridge angles are 45 and 60 degrees. The calculations with  $S = 40$  and  $S = 20$  have converged and show about 10% drag increase and 5% drag decrease, respectively. This is in agreement with the experimental findings. Wall-shear rates on most regions of the cross-sectional perimeter of riblets are smaller than those of the corresponding plane turbulent-channel flow. It appears that the drag reduction by riblets is caused by alteration of the location of the streamwise vortices with respect to the wetted surfaces (see the accompanying figure). With riblets of proper dimensions, streamwise vortices are located farther away from the wetted surfaces than in the flat-plate boundary layer and produce fewer high skin-friction regions. The total time per time step on the Cray Y-MP was 1 minute. Thus, with  $S = 20$ , approximately 200 Cray Y-MP hours were required to integrate 500 nondimensional time units. The required core memory and disk scratch spaces were 10 megawords and 40 megawords, respectively.

## Significance

The drag variation of this study with the spacing and height of the riblets matches well with the experimental results. The difficulty in the measurement of velocity fields near riblets and the modest change in skin friction and turbulence statistics have prevented a complete understanding of the mechanics of drag reduction by riblets. The data bases generated by DNS are of considerable value for the quantitative and qualitative studies of the structure of turbulence over riblets.

## Future Plans

We will analyze the detailed flow field over riblets using flow-visualization techniques and motion pictures of the flows.

## Publication

Choi, H.; Moin, P.; and Kim, J. "On the Effect of Riblets in Fully Developed Laminar Channel Flows." *Phys. Fluids A*. 3 (1991): 1892.

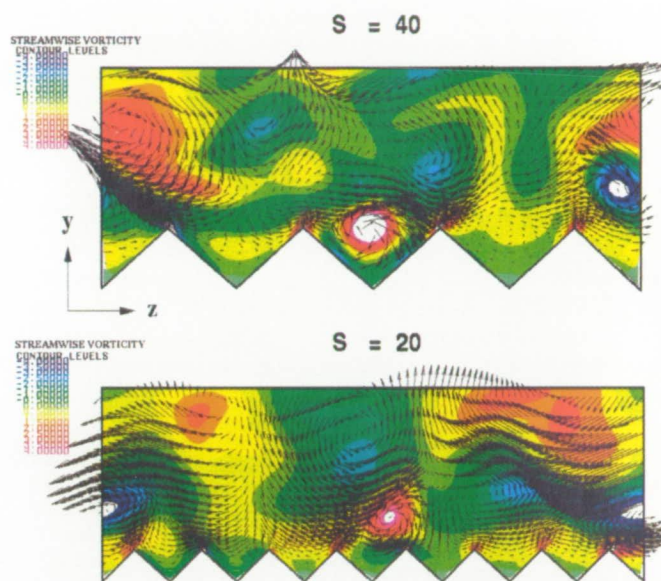

Velocity vector and contours of streamwise vorticity in a  $(z, y)$  plane.

# Turbulence Over a Backward-Facing Step

Parviz Moin, Principal Investigator  
Co-Investigators: John Kim and Hung Le  
NASA Ames Research Center

## Research Objective

To perform a direct simulation of turbulent flow over a backward facing step with inflow and outflow boundary conditions, to generate a data base for modeling, and to investigate the physics of turbulent reattachment.

## Approach

Three-dimensional time-dependent simulations of incompressible turbulent flow are performed using a second-order finite-difference method on a staggered mesh and a semi-implicit fractional-step time advancing. The inflow fluctuations are imposed using broadband spectra and are scaled to match all second-order statistics of the channel or boundary-layer flow. Convective boundary condition is applied at the exit, and periodic boundary condition is imposed in the spanwise direction. Based on the step height, the Reynolds number ( $Re_h$ ) is about 5,000. Up to  $770 \times 194 \times 66$  grid points are used.

## Accomplishment Description

The numerical results are in good agreement with experiments. The calculated reattachment length is found to be a strong function of the expansion ratio, which agrees with past experi-

mental results. Strong negative skin friction is also seen in the back-flow region. When plotted in wall coordinates, the mean velocity profiles in the recovery region are below the log-law of the wall. This may be caused by the adverse pressure gradient created by the sudden expansion. The accompanying figure shows the streamwise velocity contours on a horizontal plane at  $y^+ = 16$ . The superimposed black lines indicate the reattachment locations. The typical direct numerical simulation requires about 2,000 Cray Y-MP hours and 10 megawords of memory.

## Significance

The numerical simulations were a significant step for direct computation of complex turbulent flows with turbulent inflow/outflow conditions. The simulations have provided a comprehensive database for Reynolds-averaged modeling of complex flows.

## Future Plans

The simulations with fine-grid resolution are being continued and flow statistics, including all the terms in the Reynolds-stress budgets, will be computed.

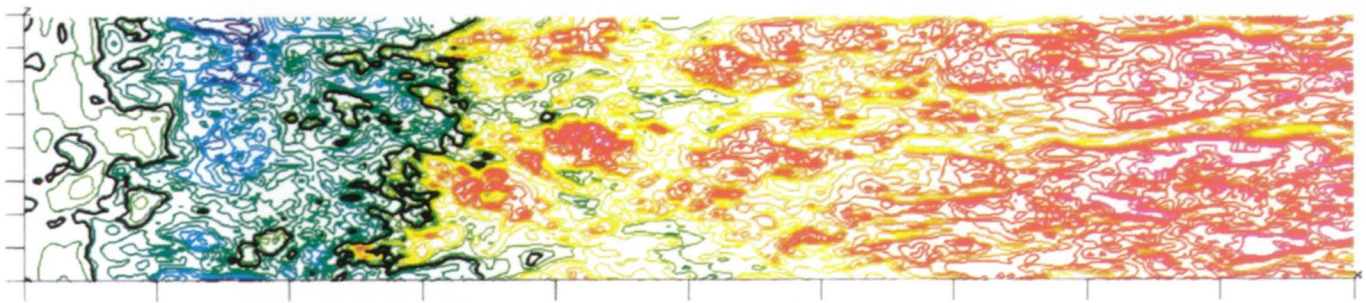

Streamwise velocity contours at  $y^+ = 16$  for  $Re_h = 5,100$ . The step is at the left boundary. The mean flow is from left to right. Dimensions = 20 height  $\times$  40 height. Velocity range: blue =  $-0.4$  to magenta =  $0.5$ .

# Aerodynamic Sound Generation

Parviz Moin, Principal Investigator

Co-Investigators: Sanjiva K. Lele, Tim Colonius, and Brian E. Mitchell  
Stanford University/NASA Ames Research Center

## Research Objective

To compute acoustic sources and far-field sound using the unsteady Navier–Stokes equations to allow direct validation of aeroacoustic theories and help provide noise control strategies.

## Approach

Accurate computation of far-field sound along with near-field hydrodynamics requires that the Navier–Stokes equations be solved using accurate numerical differentiation and time-marching schemes with nonreflecting boundary conditions. Sixth-order compact finite-difference schemes are used to evaluate spatial derivatives and time is advanced with a fourth-order Runge–Kutta scheme. Nonreflecting boundary conditions developed for the two-dimensional linearized Euler equations are modified for use with nonlinear Navier–Stokes computations of open flow problems.

## Accomplishment Description

The numerical scheme was tested on several model problems, including sound radiation in uniformly sheared viscous flow, scattering of sound waves by a compressible vortex, sound generation by a pair of corotating vortices, and the spatial evolution of a compressible mixing layer. The accompanying figure summarizes the results of the sound produced by corotating vortices. The sound level measured in the far field of the direct Navier–Stokes computations agrees well with predictions based on an aeroacoustic theory. In computations of spatially evolving free-shear flows, large-scale vortical structures are found to produce large reflections at the outflow boundary due to nonlinear effects; these reflection errors cannot be improved by increasing the accuracy of the linear boundary conditions. The addition of an exit zone just upstream from an outflow, where disturbances are significantly attenuated through grid stretching and filtering, reduces reflections from vortical structures by three orders of magnitude. The figure shows the improvement of the dilatation field associated with the rollup of a compressible mixing layer. The model problems typically use from 40 Cray Y-MP hours for each mixing-layer test to about 100 Cray Y-MP hours for the corotating vortices. The solid state device is used; therefore, core memory is typically less than 4 megawords.

## Significance

Computational aeroacoustics research is in its infancy and successful test problem simulation, including excellent agreement with theories and experiments, shows that accurate direct computation of fluid flow, with sound sources and far-field sound whose energy is 10 orders of magnitude smaller than the flow energy, is feasible.

## Future Plans

The codes developed will be used to compute the sound generation in two- and three-dimensional turbulent shear flows.

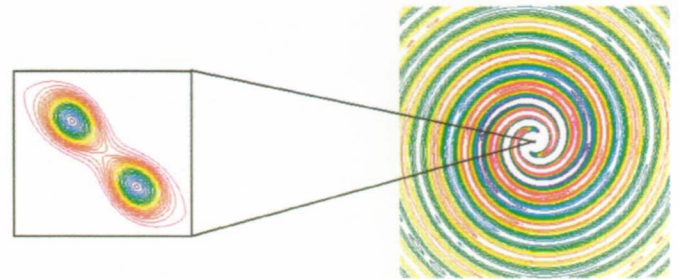

Directly computed far-field pressure from a corotating vortex pair (left). Near-field vorticity illustrates the corotating vortices generating the sound.

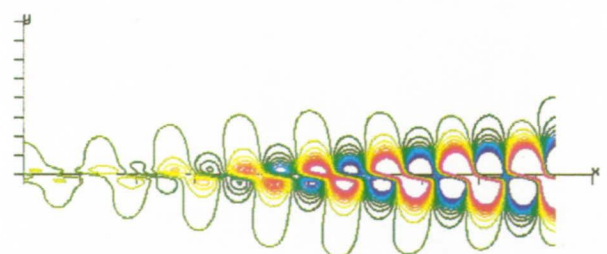
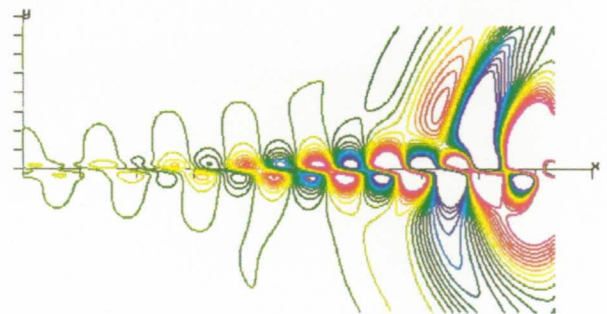
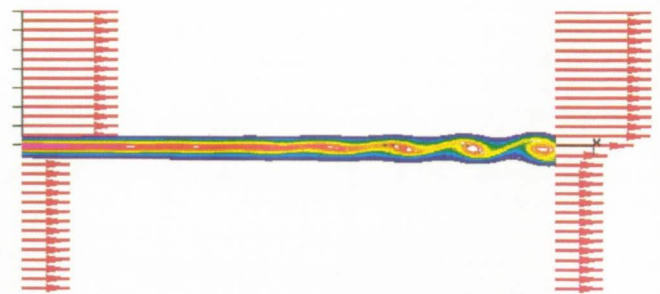

Spurious acoustic reflections at the outflow boundary of a compressible mixing layer.

# Shock-Wave/Turbulent-Boundary-Layer Interaction

Parviz Moin, Principal Investigator

Co-Investigators: Sanjiva K. Lele, Mahesh Krishnan, and Sangsan Lee

Stanford University/NASA Ames Research Center/Center for Turbulence Research

## Research Objective

To understand the mechanisms of shock-wave/turbulent-boundary-layer interaction. Interactions of a shock wave with isotropic turbulence and turbulence subject to mean shear are investigated.

## Approach

Direct numerical simulation (DNS) and linear analyses are performed.

## Accomplishment Description

In the interaction of isotropic turbulence with a shock wave, turbulent kinetic energy is rapidly amplified at the immediate downstream of the shock. Transverse components of vorticity are amplified with the normal component unchanged. Turbulence length scales decrease during the interaction. Boundary conditions for the simulation of inhomogeneous turbulence interacting with a shock wave are being developed. Unsteady boundary conditions were developed for the simulation of interaction of turbulence with oblique shock waves by applying different nonreflecting boundary conditions in different zones. The accompanying figure shows a typical dilatation field of turbulence interacting with incident and reflecting shock waves. A typical three-dimensional DNS requires approximately 200 Cray Y-MP hours, 8 megawords of memory, and 40 megawords of disk scratch space.

## Significance

Since DNS resolves all the relevant time and length scales of turbulence and a shock wave, it can provide all the physical information that cannot be measured in experiments. Thus, the data base generated by these simulations provides key information for the development of turbulence models to predict the interaction of turbulent boundary layers with a shock wave.

## Future Plans

DNS and linear analyses on the interaction of sheared turbulence with a normal shock wave will be performed. In order to investigate the interaction of a strong shock wave with turbulence in practical applications, large-eddy simulations (LES) will be performed without resolving the shock wave. The main components of the LES, such as shock-capturing schemes and subgrid scale turbulence models, will be validated by comparing them with the DNS results obtained in this work.

## Publications

1. Lee, S.; Moin, P.; and Lele, S. K. "Interaction of Isotropic Turbulence with a Shock Wave." Report No. TF-52, Department of Mechanical Engineering, Stanford University, Stanford, CA, 1992.
2. Lee, S.; Lele, S. K.; and Moin, P. "Simulation of Spatially Evolving Turbulence and the Applicability of Taylor's Hypothesis in Compressible Flow." *Phys. Fluids A*, 4, no. 7 (1992).

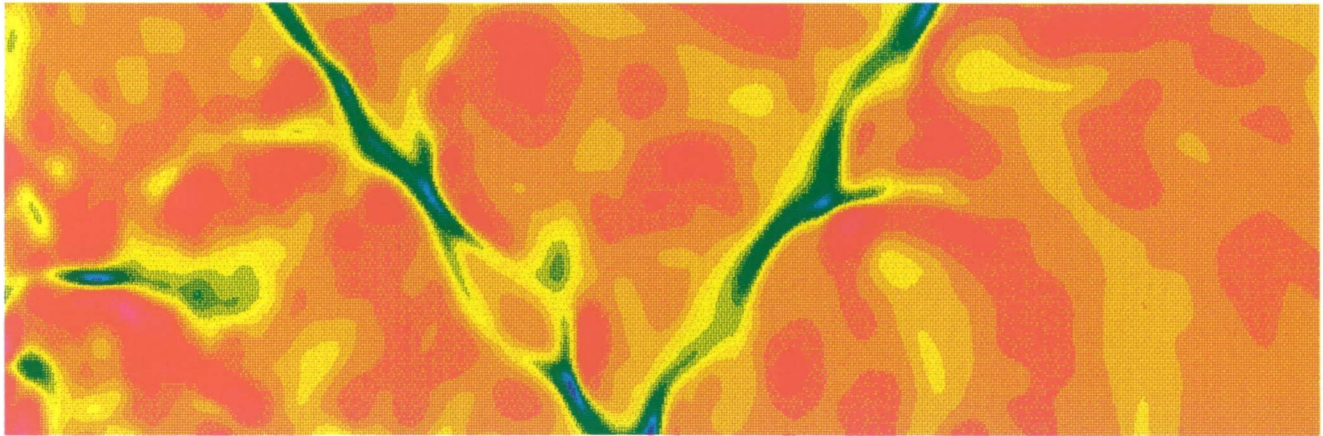

*A typical dilatation field of turbulence interacting with incident and reflecting oblique shock waves. An oblique shock wave is incident on and reflected from the bottom boundary where a slip boundary condition is applied. Along the top, boundary conditions based on exact characteristics and nonreflecting boundary conditions are used in different zones.*

# Wall-Bounded Turbulent Flows

Robert D. Moser, Principal Investigator  
Co-Investigator: John Kim  
NASA Ames Research Center

## Research Objective

To study the physics of wall-bounded turbulent shear flows, including Reynolds number effects, flow control, and coherent structures.

## Approach

We performed direct numerical simulations (DNS) of turbulent flows in simple geometries and analyzed the resulting fields.

## Accomplishment Description

Using short-time Lyapunov exponent analysis on a computed turbulent channel flow, it was found that there were several instabilities responsible for the chaotic nature of the turbulence. The instabilities include the Kelvin–Helmholtz rollup of vertical and inclined internal shear layers as well as the “flapping” of the inclined shear layers. Turbulent channel flow DNS with heat transfer at Reynolds = 700 has been performed. The small-scale structure of the turbulence has been examined by considering the three-dimensional velocity derivative field. It was found that the velocity and velocity-derivative spectra satisfy the local isotropy relations at high wave numbers.

## Significance

The mechanisms responsible for the unpredictability of turbulence are important for the development of turbulence control strategies and the development of a turbulence theory. Local small-scale isotropy of inhomogeneous turbulent flow is often assumed in developing turbulence models, but this assumption has not been well tested.

## Future Plans

The analysis of the simulations is continuing. Simulations of higher Reynolds-number flows and of compressible flows are planned.

## Publication

Antonia, R. A.; Kim, J.; and Browne, L. W. “Some Characteristics of Small-Scale Turbulence in a Turbulent Duct Flow.” *J. Fluid Mech.* 233 (1991): 369.

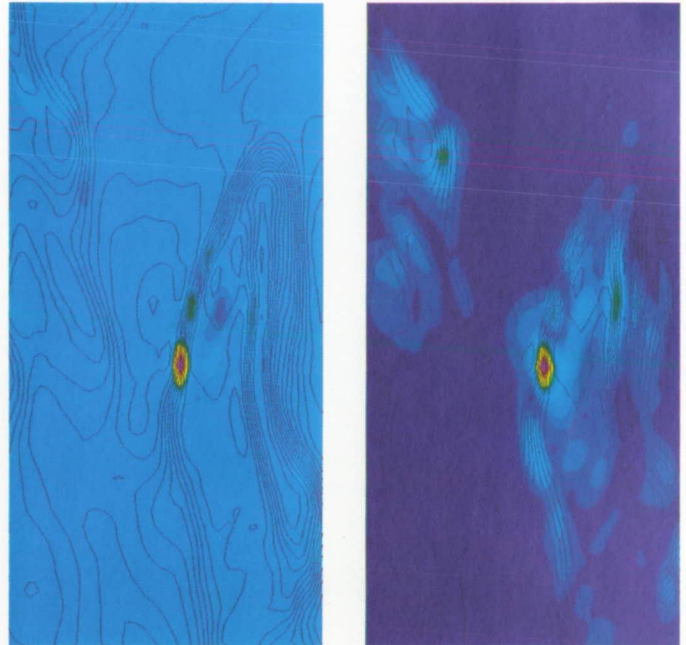

*Color contours indicate the perturbation energy (top) and the production of perturbation energy (bottom) in a plane parallel to the wall. Contour lines indicate streamwise velocity. The perturbations are growing along the shear layer indicated by the velocity contours.*

# Hypersonic Rarefied Flow about a Compression Ramp

James N. Moss, Principal Investigator  
Co-Investigator: Joseph M. Price  
NASA Langley Research Center

## Research Objective

To establish the validity of the direct simulation Monte Carlo (DSMC) method for calculating viscous interacting flows and to investigate the sensitivity of such flows to cell resolution.

## Approach

A two-dimensional DSMC code was used to calculate the flow about a flat plate followed by compression ramps. Ramp angles of 0–35 degrees were used, and the free-stream conditions were those obtained in low-density hypersonic wind tunnels at the Deutsche Forschungsanstalt für Luft- und Raumfahrt in Göttingen, Germany. For selected flow conditions, grid variation studies were made.

## Accomplishment Description

Comparison of the calculated results with experiment is very favorable. The flat plate provides a rigorous test for numerical solutions and the DSMC method appears to provide satisfactory treatment. The same can be said of the DSMC method for merged-layer or strongly interacting flows in the presence of adverse pressure gradients and separated flows. The separated-flow case for the 35 degree ramp shown in the accompanying

figure used 335,000 simulated molecules and 22,500 cells. The solution required approximately 40 Cray Y-MP hours and 4 megawords of memory.

## Significance

The design of future hypersonic vehicles will heavily rely on numerical simulations to complement and extend information obtained in ground-based and flight experiments. The validation process begun in this study ensures that a tested method exists for calculating flap-control effectiveness and heating conditions at high altitudes.

## Future Plans

Three-dimensional DSMC simulations will be conducted to account for edge-relief effects as they influence the separation and reattachment phenomena.

## Publications

Moss, J. N.; Chun, C.-H.; and Price, J. M. "Hypersonic Rarefied Flow about a Compression Corner—DSMC Simulation and Experiment." AIAA Paper 91-1313, 1991.

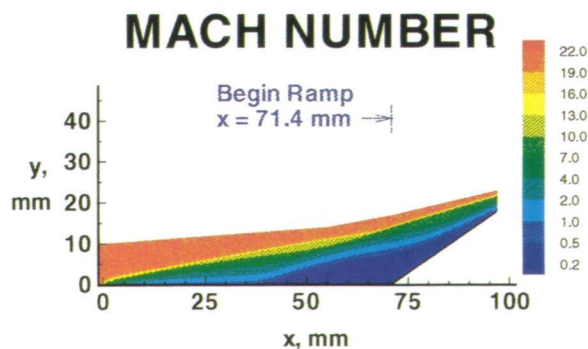
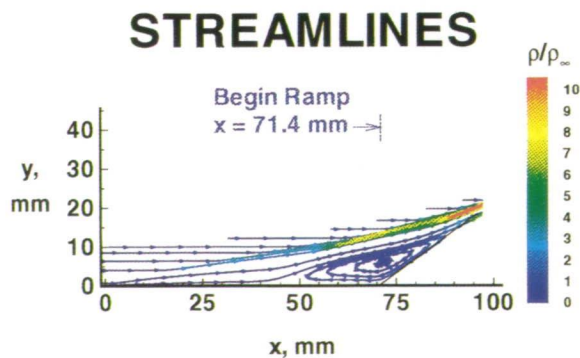
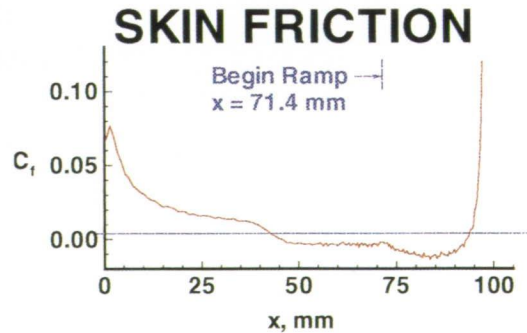
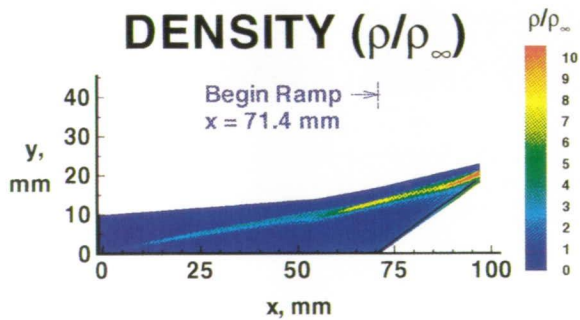

Direct simulation Monte Carlo calculations for a 35 degree ramp at Mach 21.6 nitrogen flow with  $\rho_{\infty} = 3.9 \times 10^{-4} \text{ kg/m}^3$  and a wall temperature of 341 K.

# Transonic-Shock/Boundary-Layer Interaction to Alleviate Separation

Jon S. Mounts, Principal Investigator  
Co-Investigator: Thomas J. Barber  
United Technologies Research Center

## Research Objective

To develop and apply three-dimensional numerical techniques to describe the flow field associated with vortex generators (VG) used to alleviate separation.

## Approach

The approach is to modify and couple a three-dimensional multiblock Euler and a thin-layer Navier–Stokes analysis to model the flow over and downstream from VG devices. Downstream from the VG, a shock wave interacts with an adverse pressure gradient producing a separated region. The analysis will be validated with experimental data and then used in a parametric study to design optimized VG shapes by identifying the dominant length scales.

## Accomplishment Description

A simplified analysis based on the solution of the Euler equations over a VG coupled with a Navier–Stokes applied downstream has been used to simulate the effect of shock-wave/boundary-layer interaction. A mesh was used to capture the variety of length scales inherent to the problem (e.g., boundary layer height ( $\delta$ ), VG height ( $h \approx \delta/3$ ), the axial alleviation distance ( $\approx 30-60\eta$ ), and the lambda shock triple point ( $\approx 5\delta$ )). The inviscid calculation used 175,000 grid points (4 blocks) and required 40 megawords of storage on the Cray-2. The viscous calculation used 225,000 grid points (3 blocks) and required 64 megawords of storage. The first figure shows a three-dimensional display of the induced vorticity, the surface streamlines, and the axial velocity field. The analysis results indicate a surface flow “owl’s-eye” pattern similar to those observed experimentally, and a reduction of the reverse flow region at the point of separation and in the thickness of the reverse-flow bubble. These calculations require approximately 60 Cray Y-MP hours. Parametric inviscid flow analyses were conducted to investigate the effect of varying VG geometrical length scales and shapes. Performance assessment entails evaluating the shed streamwise vorticity, the net circulation, and the energization of the axial component of velocity. The second figure illustrates the calculated induced vortical flow fields for several configurations studied.

## Significance

Normal shock/boundary-layer interaction separation occurs in many aerodynamic devices, such as transonic inlets, diffusers, and airfoils, resulting in detrimental effects on drag and pressure recovery. Alleviating or reducing the effects of these phenomena will have a significant impact on the efficiency of aerodynamic devices.

## Future Plans

Future work on this project has not yet been determined.

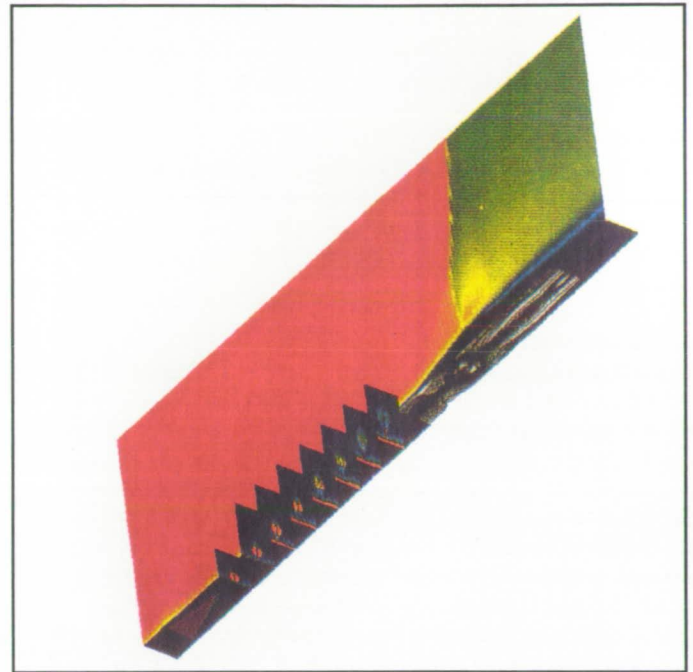

*Transonic-shock/boundary-layer interaction alleviation due to vortex generation.*

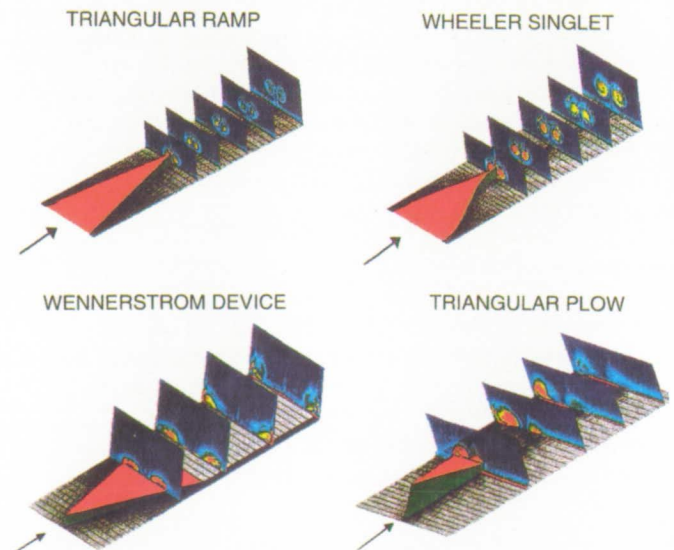

*Parametric vortex generation analyses.*

# Rotorcraft Drag Prediction

J. C. Narramore, Principal Investigator

Co-Investigators: A. G. Brand and D. W. Axley

Bell Helicopter Textron, Inc.

## Research Objective

To develop the capability to predict forces and moments, including drag, on complete rotorcraft vehicles.

## Approach

We utilized three-dimensional Navier–Stokes codes to perform both the steady and unsteady analyses of rotor blades and fuselages in flight and correlated these results with existing wind tunnel data. Both code and grid topology investigations were carried out.

## Accomplishment Description

Research pertaining to the calculation of forces on three-dimensional rotor blades and fuselages, with special emphasis on the calculation of drag levels, has been performed. Work has been focused in three areas: correlation of flows about fuselages, correlation of flows about complex rotor tips, and modeling of inlet flows. Navier–Stokes solutions for the flow about a helicopter fuselage at Mach 0.23 were compared to wind tunnel test data with grid topology, angle of attack, and yaw angle being varied. The best correlation was obtained from the C-O grid topology (see accompanying figure). The difference between the measured drag and the computed drag was only 4% for a low angle-of-attack case, 7% for a high angle-of-attack case, and 13% for a high-yaw case when this grid topology was used.

## Significance

Computational fluid dynamics methods offer high potential for improved rotorcraft design and performance capabilities. This new technology should reduce vehicle costs, improve performance, and reduce development cycle times. Accurate assessment of blade and fuselage drag in maneuvers, transonic flight, or at high angle of attack is crucial to rotorcraft predictive and design methodology. The first Navier–Stokes solutions that correlate well with measured drag levels on a typical helicopter fuselage were obtained.

## Future Plans

We will (1) modify the boundary conditions on a Navier–Stokes code to allow the modeling of an actuator disk; (2) correlate wind tunnel data for a ducted-tail-rotor model to the results from this Navier–Stokes method; (3) use a Navier–Stokes code to investigate the flow about an anhedral rotor-tip shape; and (4) develop Navier–Stokes solutions for a more complex helicopter rotor fuselage using C-O and H-H grid topologies and compare the results with test data.

## Publications

1. Scott, M. T. and Narramore, J. C. "Navier–Stokes Correlation of a Swept Helicopter Rotor Tip at High Alpha." Presented at the AIAA 22nd Fluid Dynamics Conference, Honolulu, HI, June 1991.
2. Narramore, J. C. and Brand, A. G. "Navier–Stokes Correlations to Fuselage Wind Tunnel Data." Presented at the 48th Annual Forum of the American Helicopter Society, Washington, DC, June 1992.

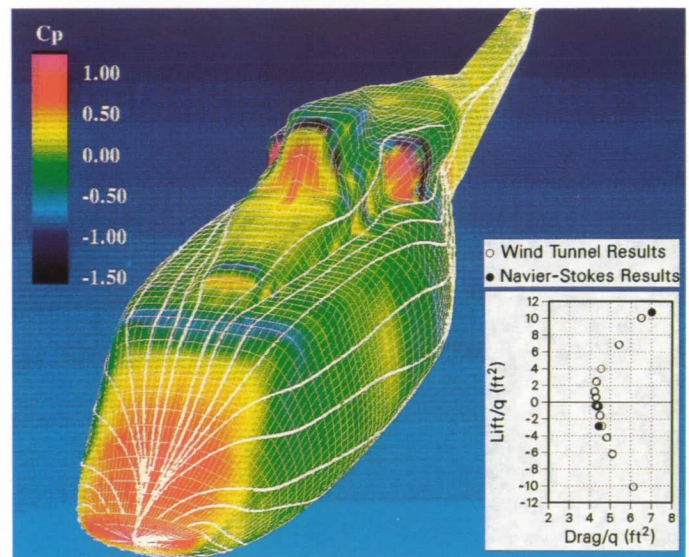

Navier–Stokes results correlate with wind tunnel drag measurements.

# Controlling Combustion in Free-Shear Layers

David Nixon, Principal Investigator  
Co-Investigator: Laurence Keef  
Nielsen Engineering and Research, Inc.

## Research Objective

To investigate the generic effects of heat release on free-shear layers, particularly theoretical predictions that asymmetrical heat release can promote mixing and layer spreading.

## Approach

We will test three-dimensional direct numerical simulations of low-Reynolds-number, spatially developing, compressible shear layers. First, we will test arbitrarily specified heat release, then we will test a simple three-component chemical reaction.

## Accomplishment Description

After the addition of an independently specifiable heat-release term to the energy equation in our Navier–Stokes simulations, the effect of steady, but spatially varying, heating on a two-dimensional layer was investigated. Because of the particular spatial form chosen, the total heat release per unit of streamwise distance was constant, thus it was consistent with linear growth of a reacting shear layer. Previous experiments and simulations have left the impression that heating always reduces shear-layer growth. Our theoretical work indicates that an asymmetric heat-release profile across the layer can actually increase layer growth. So far, the numerical work has confounded both expectations. Although mixing rate increases due to heating asymmetry have not been found, neither have noticeable decreases in mixing been detected at the heating rates employed. The figure displays the mixing rates of heated and unheated mixing layers at  $M_c = 0.4$ . Despite a greater than 30% rise in centerline temperature in the heated case, the spreading rate, measured by the vorticity thickness ( $\delta_\omega$ ), is essentially unaffected. Such results have prompted a reexamination of the theory. The calculations required to obtain developed three-dimensional shear layers and statistics on local Mach numbers took roughly 7 Cray Y-MP hours and 16 megawords of memory.

## Significance

This work tests the basic assumptions underlying a novel theory linking heat-release asymmetry to increased mixing.

## Future Plans

We will exercise the simple chemistry model and perform experiments where the heat release profile across a shear layer is tailored to increase mixing. Also, we will determine if the resulting flow configurations are practical to implement in a high-speed combustor setting.

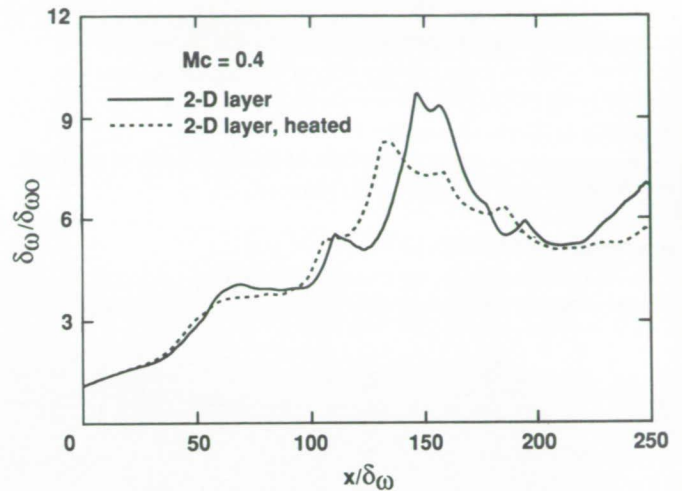

Mixing rates of heated and unheated mixing layers.

# Thermomechanical Buckling and Post-Buckling of Multilayered Composite Panels with Cutouts

Ahmed K. Noor, Principal Investigator  
 Co-Investigator: Jeanne M. Peters  
 NASA Langley Research Center/University of Virginia

## Research Objective

To study the thermomechanical buckling and post-buckling responses of multilayered composite panels with cutouts.

## Approach

The computational model of the composite panels used in this study is based on the geometrically nonlinear shallow-shell theory, with the effects of both transverse shear deformations and temperature dependence of the material properties included. Analytic sensitivity coefficients are evaluated, measuring the sensitivity of the post-buckling response to variations in material and lamination parameters. The panels are subjected to combined applied-edge displacement and temperature increase. An efficient reduced-base computational procedure is used for determining the stability boundary, generating the post-buckling response and evaluating the sensitivity derivatives. The procedure allows the number of degrees of freedom used in the initial discretization to be significantly reduced.

## Accomplishment Description

Extensive numerical studies were performed to understand the effects of temperature dependence of material properties,

lamination parameters, and the size of the cutout on the stability boundary and post-buckling response of flat unstiffened panels. The first figure shows the affect of hole size on the stability boundary for a 16-layer quasi-isotropic panel with fiber orientation. The second figure compares the normalized total-strain energies in the post-buckling range for two panels, one with and one without a cutout, when subjected to temperature increase. The third figure shows the sensitivity coefficients with respect to material parameters.

## Significance

The structures of future high-speed and high-performance aircraft will be subjected to higher temperatures for longer periods. This study will help in the lamination selection and identify the material systems required.

## Future Plans

Detailed studies of the effect of temperature dependence of material properties will be conducted. Stiffened panels with cutouts will also be considered. The numerical simulations will be closely coupled with laboratory experiments to identify the failure mechanisms and develop failure criteria for the panels.

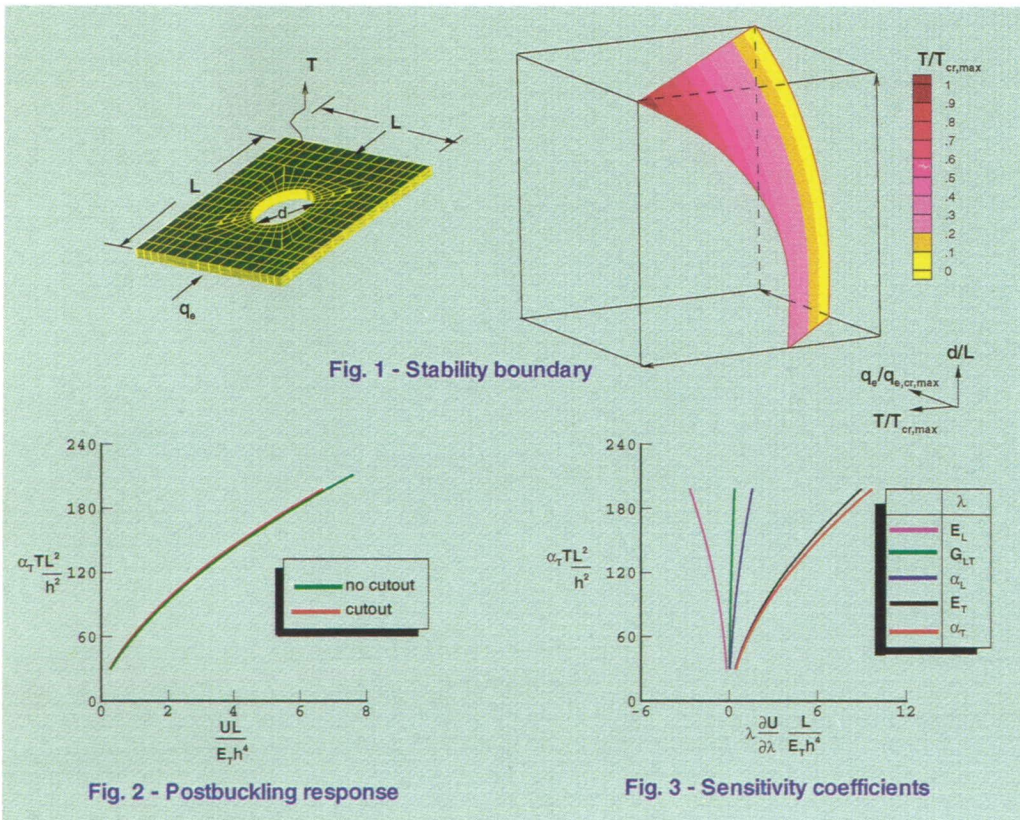

The effects of temperature dependence of material properties, lamination parameters, and the size of the cutout on the stability boundary and post-buckling response of flat unstiffened panels.

# Space Transportation Vehicle Aerothermodynamics

Grant Palmer, Principal Investigator

Co-Investigators: Susan Tokarcik, Ethiraj Venkatapathy, and William J. Feiereisen

NASA Ames Research Center

## Research Objective

To determine if the effects of self-generated and/or externally applied magnetic fields have a significant impact on the flow behind the bow shock wave of an aerobrake returning at hypersonic velocities from a lunar or Mars mission and if these effects are of consequence to vehicle design.

## Approach

The axisymmetric thermochemical non-equilibrium Navier-Stokes equations with finite-rate chemical reactions are loosely coupled with Maxwell's equations and are solved using upwind-differencing flow codes.

## Accomplishment Description

Flow was computed over a Mars-return aerobrake at 13.2 km/sec corresponding to a flight trajectory point of 64.8 km altitude. Peak ionization levels along the stagnation streamline exceeded 25%. This level of ionization produced a self-generated magnetic field of 1.86 Gauss. This level of magnetic induction had

no discernible effect on the other flow quantities. It was shown that an externally applied magnetic field of 0.1 Tesla, a moderately strong magnetic field, increased the computed shock-standoff distance by a factor of two. The effect of an externally applied magnetic field was found to vary as a function of the field strength squared. A typical calculation took 6 Cray-2 hours and required 5 megawords of memory. The accompanying figure shows self-generated magnetic induction contours over the aerobrake.

## Significance

Including the magnetic terms with the equation doubles the CPU cost of a flow computation. This study shows that the effects of undisturbed self-generated magnetic induction are negligible for estimated trajectories of Mars-return aerobrakes.

## Future Plans

There is no continuation of this study because the research objective has been definitively answered.

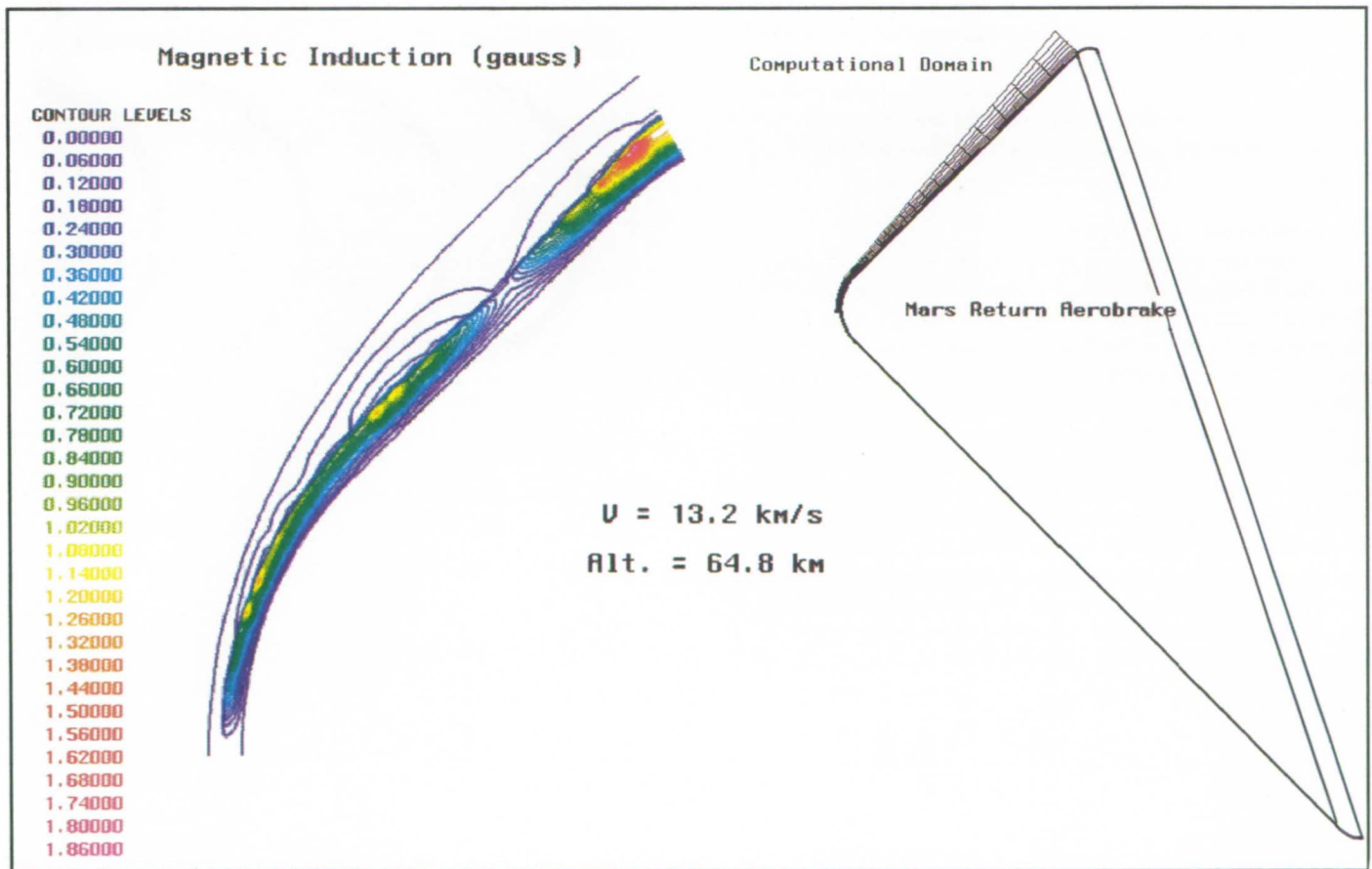

Self-generated magnetic field around a Mars-return aerobrake.

# Thermo-Viscoplastic Analysis of an Engine-Cowl Leading Edge

Ajay K. Pandey, Principal Investigator

Lockheed Engineering and Sciences Company/NASA Langley Research Center

## Research Objective

To predict the thermo-viscoplastic response of an engine-cowl leading edge subjected to oscillating shock-shock interaction.

## Approach

Prediction of thermo-viscoplastic response of an engine-cowl leading edge involves predicting the temperature solution and then performing structural analysis using a unified viscoplastic constitutive relation. First, aerodynamic heating and pressure due to oscillating shock-shock interaction is determined. These loads vary in both space and time. For the specified aerodynamic heating, radiation, and other boundary conditions, thermal analysis is performed by solving the energy equation. Resulting transient temperature response and specified pressure are used to predict structural response by solving the structural equilibrium equation. The unified viscoplastic model is used in the structural analysis and relates plastic strain rates in terms of stresses and internal state variables, combining the time-independent and time-dependent responses into a single inelastic component. The internal-state variable represents hardness of the material and is given in time-rate form in terms of temperature dependent material properties and plastic work rate. Since the unified viscoplastic constitutive relations are highly nonlinear, very small time steps are required to march the solution in time. An adapted unstructured finite-element mesh is used to improve the solution accuracy and computational efficiency.

## Accomplishment Description

A finite-element thermo-viscoplastic code was used to predict thermo-viscoplastic response. An unstructured finite-element mesh was adapted from an initial solution using temperature and circumferential stress as the key parameters. A peak temperature of about 3,000 °R was predicted on the outer surface of the leading edge during the inward and outward movement of the shock. Elastic analysis over-predicted the circumferential stresses on the leading edge and was about 50% higher than the stresses predicted by thermo-viscoplastic analysis in the region of peak aerodynamic heating and pressure. Analysis also predicted permanent plastic deformation on the leading edge. The accompanying figure shows the increase in plastic region as the shock moves inward and outward. The effective plastic-strain contour shows that the peak effective plastic strain keeps increasing with time.

## Significance

The leading edge experiences intense aerodynamic heating resulting in high temperatures where viscoplastic effects are significant. Stresses predicted by thermo-viscoplastic analysis are significantly lower than the elastic analysis in the peak heating region. Thermo-viscoplastic analysis identifies the regions undergoing plastic deformation. Use of an adaptive finite-element method significantly reduces the problem size.

## Future Plans

We will study the transient thermal and viscoplastic response of three-dimensional leading-edge structures using adaptive finite-element methods.

## Publication

Pandey, A. K. "Thermo-Viscoplastic Analysis of Engine-Cowl Leading Edge Subjected to Oscillating Shock-Shock Interaction." Presented at the AIAA 33rd Structures, Structural Dynamics, and Materials Conference, Dallas, TX, April 1992.

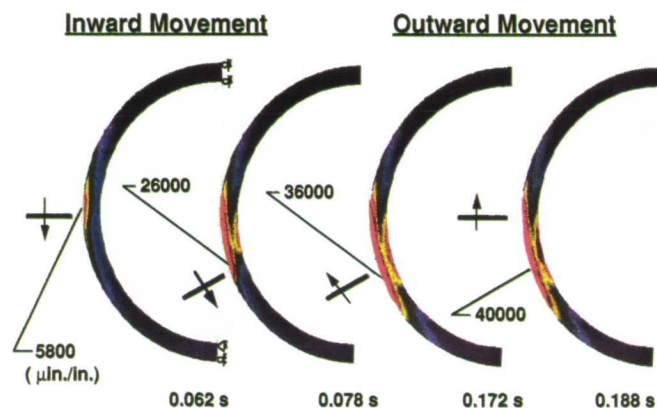

Effective plastic-strain contours.

# Afterbody Aerodynamics with Canted Pitch-Vectoring Twin Nozzles

S. Paul Pao, Principal Investigator  
Co-Investigator: K. S. Abdol-Hamid  
NASA Langley Research Center/Analytical Services and Materials, Inc.

## Research Objective

To obtain detailed surface and field-pressure distributions, identify regions of flow separation, and calculate the mass flow rate and forces of the jet propulsion system. The installation of twin rectangular thrust-vectoring nozzles for advanced aircraft propulsion has many advantages. However, it is both geometrically and aerodynamically complex.

## Approach

A multiblock structured-grid Navier–Stokes code, PAB3D, is used for the numerical analysis. Algebraic and two-equation  $k-\epsilon$  turbulence modeling are available within PAB3D. A multiblock grid generator has been developed in-house for the canted twin-nozzle/afterbody configuration. Half-body grids are used for studying the symmetrical pitch-vectoring configurations. Full-body grids will be necessary for cases where pitch and yaw forces are effected by the nonsymmetrical diverging-flap setting of the twin nozzle system.

## Accomplishment Description

A 54-block surface-fitted grid was generated for the right half of the twin-nozzle/afterbody with a zero degree vector angle for the nozzle. The unusual blocking strategy provided a grid that is well matched in terms of orthogonality and spacing, and is a continuous boundary layer over the afterbody and the nozzle interior. One solution, for free-stream Mach number 1.2 and nozzle pressure ratio 4.0, was obtained during this project period. Surface-pressure coefficient contours on the twin-nozzle/afterbody configuration are shown in the accompanying figure. Significant findings include a local-shock compression zone upstream from the nozzle assembly (top of figure), non-symmetrical flow separation above and below the nozzle assembly, and jet-plume interaction with the flow behind the afterbody. This half-body grid contains 550,000 grid points and requires 11 megawords of memory. A converged solution takes approximately 5,000 iterations, requiring 30 Cray Y-MP hours.

## Significance

Numerical results from this investigation are useful in understanding the aerodynamics for complex configurations. The results also provide a quantitative basis for drag-reduction design and the prevention of afterbody flow separation. Although experimental data for force measurements are available, surface pressure data have not yet been obtained for this configuration.

## Future Plans

We will study the effect of turbulence modeling and unstructured-grid Euler calculations, possibly including hybrid structured/unstructured computations for efficient representation of the boundary-layer, separated-flow, and jet-plume interactions.

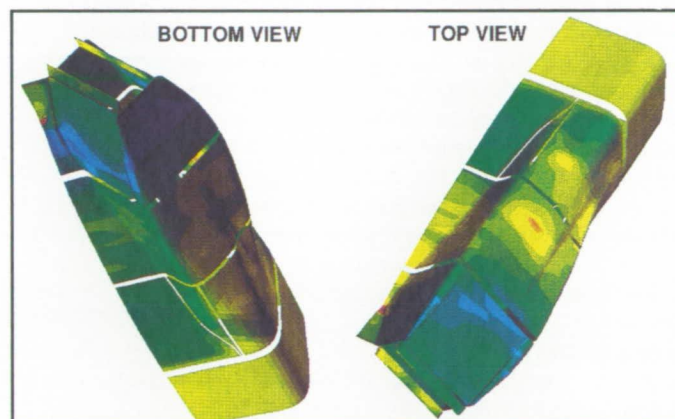

*Canted twin pitch-vectoring nozzles–afterbody pressure-coefficient contours. Mach number = 1.20, nozzle pressure ratio = 4.03, contour level from blue to red  $-0.75-0.65$  at 0.05 intervals.*

# Hydrodynamics of Self-Propelled Bodies

V. C. Patel, Principal Investigator  
Co-Investigator: F. Stern  
University of Iowa

## Research Objective

To extend and further develop the Iowa Institute of Hydraulic Research (IIHR) numerical method for solution of the Reynolds-averaged Navier–Stokes (RANS) equations to simulate the flow around complete hydrodynamic vehicles with appendages and propellers.

## Approach

The IIHR numerical method solves the complete RANS equations in numerically generated, body-fitted, nonorthogonal coordinates for unsteady three-dimensional turbulent flows. A two-equation turbulence model is used, either with wall functions or in conjunction with a one-equation model for the near-wall flow. Several basic numerical and physical problems, including grid generation for complex shapes and moving boundaries, time accuracy for unsteady flows, and turbulence model development are investigated. To generalize the method for prediction of unsteady flow around three-dimensional marine vehicles and propellers, a number of interrelated model problems have been formulated. Among these are: the flow around bodies at incidence and two-body junctions to study the topology of three-dimensional flow attachment and separation, and evaluation of turbulence models; the flow around a propeller to resolve the viscous flow over and around the blades; and the flow over bodies with appendages and/or propellers.

## Accomplishment Description

The flow on a prolate spheroid at various incidence angles and the flow around a hemisphere placed on a flat wall have been computed to clarify the topology of separation. Studies have been completed both for the SR-7 turboprop for on-design and off-design conditions and for the interaction between a marine propeller and a representative ship hull, including comparisons with available experimental data. Zonal methods, advanced turbulence modeling for simplified geometries, and time-accurate unsteady flow calculations for natural and forced unsteady flows using overlaid grids were also implemented. Average job-run Cray hours and memory requirements are: three-dimensional steady flow computation, 7 Cray-2 hours and 13 megawords of memory; two-dimensional fixed-grid unsteady flow computations, 2 Cray-2 hours and 3 megawords of memory; the more complex overlaid-grid unsteady flow computation, 10 Cray-2 hours and 4 megawords of memory.

## Significance

This research is being carried out to advance the technology base for the design of marine vehicles and propellers. The problems addressed relate to critical gaps in our knowledge of complex three-dimensional unsteady turbulent-shear flows.

## Future Plans

The numerical method is being revised to achieve greater accuracy and efficiency for unsteady flows. Steady and unsteady flow calculations for realistic marine propeller geometries are being developed. Unsteady flow calculations to study the interaction between natural and forced unsteady flows using overlaid grids will also be studied.

## Publication

Patel, V. C. "Three-Dimensional Flow Separation." *Fifth Asian Fluid Mechanics Congress*. Taejon, Korea, Aug. 1992.

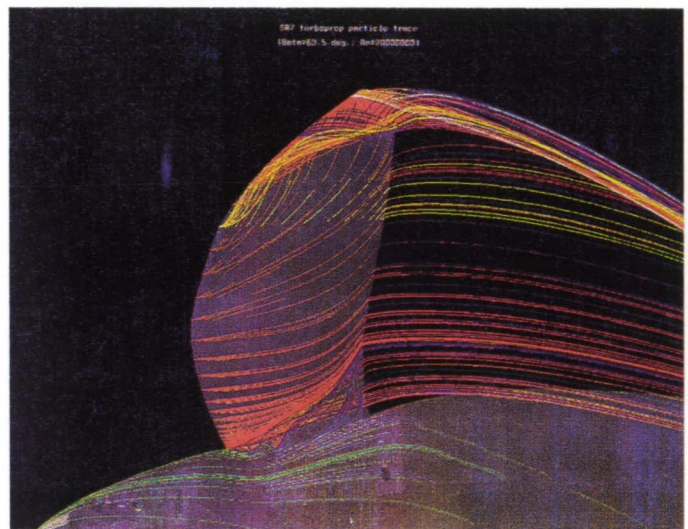

*SR-7 turboprop leading-edge and tip-vortex flow pattern.*

# Hypersonic Scramjet Flow

Principal Investigator: Darrell W. Pepper  
Co-Investigators: Frank P. Brueckner and Kevin L. Burton  
Advanced Projects Research, Inc.

## Research Objective

To predict the internal flow field of a hypersonic scramjet engine in conjunction with development of the hypersonic engine for the National Aero-Space Plane (NASP). Numerical simulations of the inlet, combustor, and nozzle sections of the engine are necessary to predict engine efficiency and performance.

## Approach

Both two- and three-dimensional Navier–Stokes codes based on unstructured grids and finite-element methods are being used to model supersonic and hypersonic internal flows in combustor–nozzle configurations.

## Accomplishment Description

The goal is to develop a reliable multidimensional algorithm for simulating compressible inviscid and viscous flows. Continued refinement of the finite-element code, RUBY3D, was undertaken last year. Incorporation and testing of a finite-rate chemistry module within RUBY2D was completed. In addition, parallel versions of the code were developed and run on a MasPar 1216 SIMD massively parallel computer (16,384 processing elements). The RUBY family of codes include two- and three-dimensional and axisymmetric capabilities for solving Euler and viscous laminar-flow regimes. All the codes are explicit, employ Petrov–Galerkin weighting for the advection terms, and utilize unstructured meshes. Modifications are employed in all the codes to enhance solution speed and reduce storage. The codes interface with PATRAN, a commercial grid generation package for preprocessing and grid generation. PLOT3D, a NASA Ames program for graphical post-processing, can be used to display two- and three-dimensional structured mesh results generated by the RUBY codes. A three-dimensional mesh of a round-to-rectangular nozzle and surface pressure contours for Mach 3 inflow are shown in the accompanying figures. To generate the mesh, 55,000 elements were used. An average inviscid job run required 1 Cray Y-MP hour and 7 megawords of memory.

## Significance

Successful simulation of the internal reacting flow field is important in the design and understanding of engine performance and airframe integration. Sufficient wind tunnel data can be taken in scramjet engine tests up to Mach 8. However, the NASP requirements extend from low subsonic to Mach 25 conditions. Consequently, numerical simulation is required to design the engine and airframe beyond present experimental limits.

## Future Plans

The reacting flow capability of RUBY2D will be extended to the three-dimensional algorithm with the addition of turbulence models planned for all programs. Optimization of the RUBY codes for increased parallel performance and incorporation of three-dimensional mesh adaptation will be continued.

## Publications

1. Burton, K. L. and Pepper, D. W. "An Adaptive Finite-Element Algorithm for Compressible Flow on Workstations." Presented at the ASME WAM, Atlanta, GA, Dec. 1991.
2. Pepper, D. W.; Jacobsen, K. P.; and Rajan, M. "A Hybrid Finite-Element Method for Calculating Compressible Flow on a Massively Parallel Computer." Presented at the Fourth International Symposium in CFD, Davis, CA, Sept. 1991.

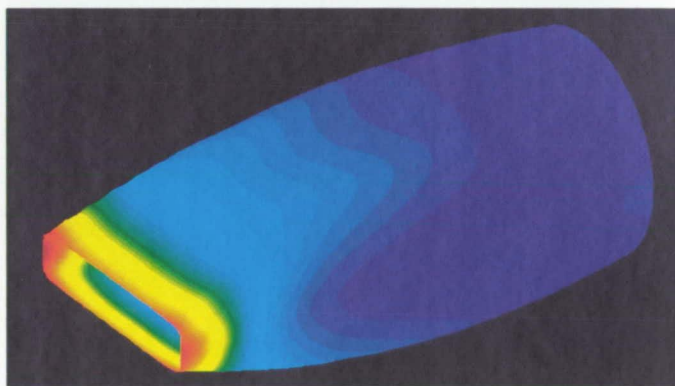
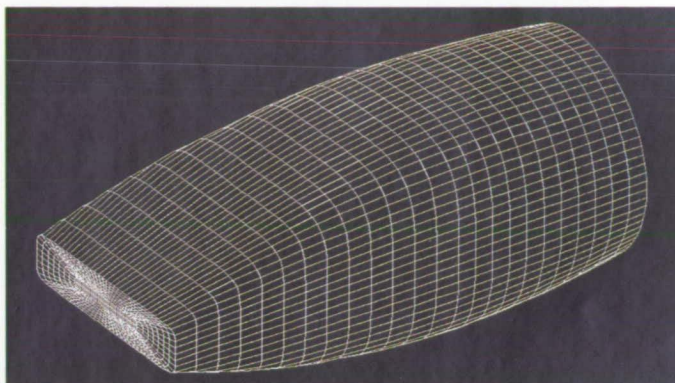

*Three-dimensional mesh of a round-to-rectangular nozzle and surface pressures for Mach 3 inflow.*

# Wave-Induced Transports

Leonhard Pfister, Principal Investigator  
NASA Ames Research Center

## Research Objective

To develop a better understanding of the role of atmospheric waves in the momentum budget of the Earth's stratosphere, stratosphere-troposphere mass exchange, and stratospheric mixing.

## Approach

We use a linear three-dimensional time-dependent approach to simulate stratospheric gravity waves observed during the tropical phase of the Stratosphere-Troposphere Exchange Project, a 1987 ER-2 aircraft field experiment based in Australia. The fields are represented as two-dimensional  $160 \times 160$  Fourier series at 100 altitudes. Each Fourier component is independently integrated in time. The convective forcing, located at the tropopause, took the form of temporary "mountains" poking into the stratosphere. The temporal and horizontal scales of these mountains were based on infrared imagery from the GMS Japanese Geostationary weather satellite. By matching ER-2 aircraft observations with the simulation, we were able to place constraints on the forcing amplitudes of tropical convection.

## Accomplishment Description

The simulations (an example is shown in the accompanying figure) showed that the mesoscale upward displacement of material surfaces by the convection is about 450–600 meters. They also produced an unexpected result. By noting the difference between the observed and simulated decay phases of the wave, we deduced that wave breaking and subsequent nonlinear interaction was occurring at the aircraft flight altitude. This implies that the waves excited by convection can directly drive the flow in the lowest 3–4 km of the stratosphere. A typical run took about 20 Cray-2 minutes used 40 megawords of internal memory.

## Significance

The calculated magnitudes of convectively induced displacements have two major implications. First, mesoscale gravity waves excited by convection have sufficient amplitude to make a significant contribution to the upper stratosphere semiannual wind oscillation and the lower stratosphere quasi-biennial oscillation. The latter strongly contributes to interannual variations in the ozone distribution. Second, wave breaking in the lowest 3–4 km of the stratosphere may have a contribution comparable to that of radiative heating in driving stratospheric upward motion.

## Future Plans

We will use a three-dimensional nonlinear model to simulate the interaction of convectively excited gravity waves with the mean lower-stratospheric circulation. This is to evaluate the contribution of these waves to tropical stratosphere-troposphere exchange.

## Publication

Pfister, L.; Scott, S.; Loewenstein, M.; Bowen, S.; and Legg, M. "Mesoscale Disturbances in the Tropical Stratosphere Excited by Convection: Observations and Effects on the Stratospheric Momentum Budget." Accepted for publication in the *Journal of the Atmospheric Sciences*, 1992.

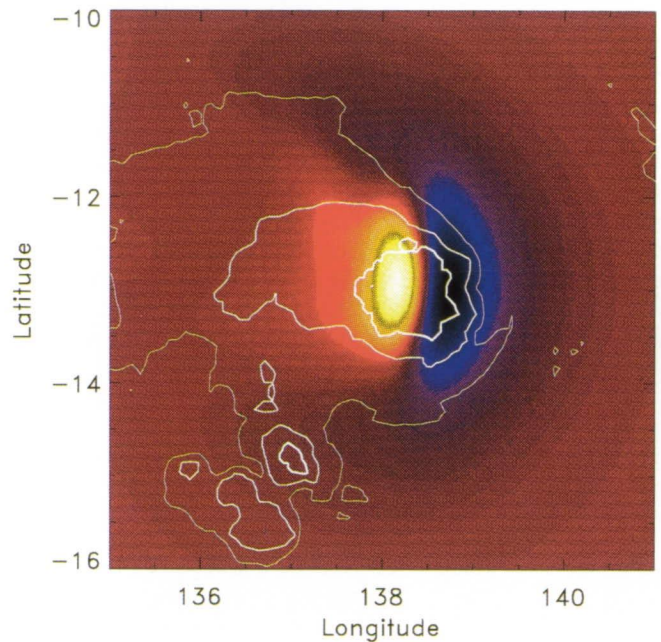

Temperature field of a simulated transient linear-gravity wave 1.5 km above the tropopause (white = 197.5 K and black = 192.5 K). The convective forcing is contoured in white, with the highest and coldest clouds outlined by the thickest lines.

# Rocket-Base Flow-Field Simulations

Thanh T. Phan, Principal Investigator

Co-Investigator: Richard J. Magnus

General Dynamics, Space Systems Division

## Research Objective

To develop an accurate and economical technology capable of numerically simulating the complete flow field around a multi-body launch vehicle interacting with its multi-engine plumes.

## Approach

The three-dimensional Reynolds-averaged Navier–Stokes flow solver, FALCON, is used to simulate the flow field in the base region of the launch vehicle. The code employs a finite-volume, cell-centered, upwind-differencing scheme that includes a k-kl turbulence model. A multiblock grid structure is used to conform to the complex geometry of the base region.

## Accomplishment Description

A perfect-gas turbulent solution was obtained for the base region of an Atlas II launch vehicle (no solid-rocket boosters) at Mach 1.8. Seven grid blocks totaling over one million points were used. Local time stepping at each cell was applied to accelerate convergence to steady state. The solution required approximately 14 megawords of memory and 70 Cray Y-MP hours.

## Significance

Currently, the environment in the base region of a new launch system is predicted with very large uncertainties. These uncertainties lead to designs of thermal protection systems that include many over-conservatisms that cannot be used with a high level of confidence. The calculations in this research will provide valuable information to help design optimal protection systems that can be used with more confidence.

## Future Plans

Real-gas effects and flow-field grid adaptation will be implemented to model plume interactions more accurately. Forebody effects will eventually be simulated, including the solid-rocket boosters and their exhaust products.

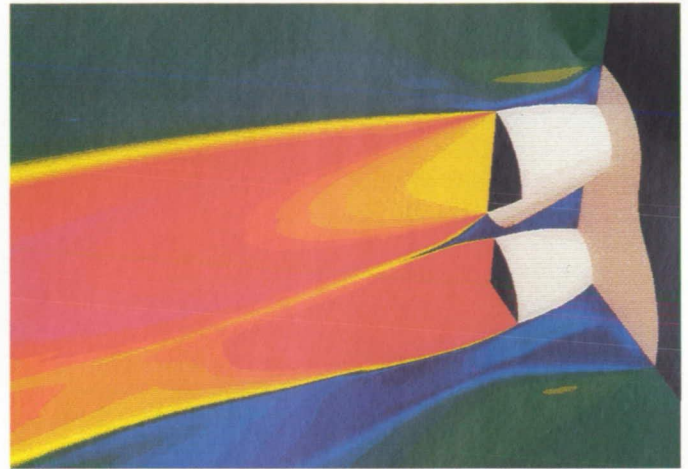

*Mach number contours.*

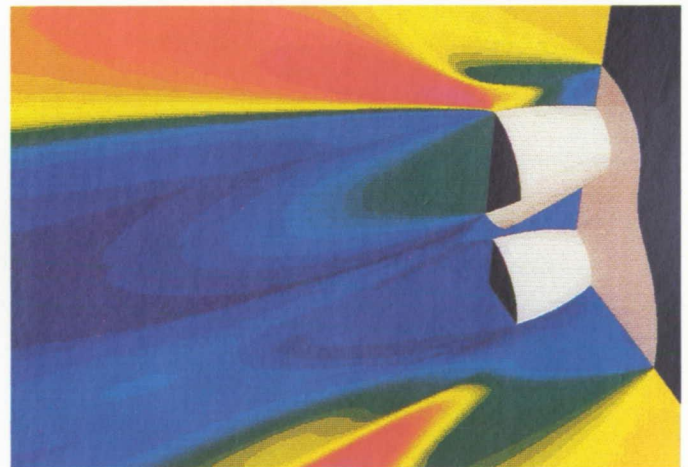

*Perfect-gas turbulent solution for an Atlas II base flow at Mach 1.8.*

# Three-Dimensional Liquid-Sloshing Flows

Richard H. Pletcher, Principal Investigator

Co-Investigators: Franklyn J. Kelecy and Babu Sethuraman

Iowa State University

## Research Objective

To develop numerical simulation methods for predicting the complex, transient, three-dimensional motion of a sloshing liquid in a partially-filled container undergoing arbitrary motion.

## Approach

The motion of a sloshing liquid is governed by the three-dimensional incompressible Navier–Stokes equations. The presence of the free surface poses special problems as its position is not known a priori and has to be evaluated as part of the solution. Two approaches, surface fitting and surface capturing, are being evaluated. The surface-fitting code (SLOSH3D) places the free surface at the boundary of the computational domain. The free-surface position is estimated using a kinematic boundary condition. The motion of the free-surface boundary necessitates the use of a moving grid, which is updated once the new free-surface position is known. The flow-field solution inside the liquid is obtained by using the artificial compressibility approach in conjunction with a coupled strongly implicit procedure (CSIP) to solve the resulting system of equations. The surface-capturing approach also uses artificial compressibility, but solves conservation equations in both liquid and gas phases on a stationary grid, thus “capturing” the free surface as a density discontinuity.

## Accomplishment Description

The CSIP algorithm was vectorized along surfaces of constant index sums and optimized for use on the Cray Y-MP. A typical

transient calculation (using 5,000 grid points and 3,000 time steps) required about 5 megawords of memory and 1 Cray Y-MP hour. The code has been used to compute transient solutions for symmetric spin-ups and asymmetric orbital motions of half-filled spherical containers. Selected results for the case of a simple orbital spin-up to a steady-state angular speed of 60 rpm are presented in the accompanying figures. The free-surface position is depicted at different times during the transient, illustrating the complex three-dimensional surface behavior as it approaches steady state. Comparisons with experimental data showed good agreement.

## Significance

Liquid sloshing arises in many important areas, including the National Aero-Space Plane and various space and space station projects. Forces generated by liquid motion can result in damage or instability in vehicles. Numerical methods for sloshing flows provide an important tool for analyzing the details of the fluid motion and its effects on the container structure.

## Future Plans

We will enhance the simulation capability to higher Reynolds numbers. Work is progressing on integrating the sloshing calculations with a finite-element structural model so that the fluid–structure system interaction can be investigated in detail.

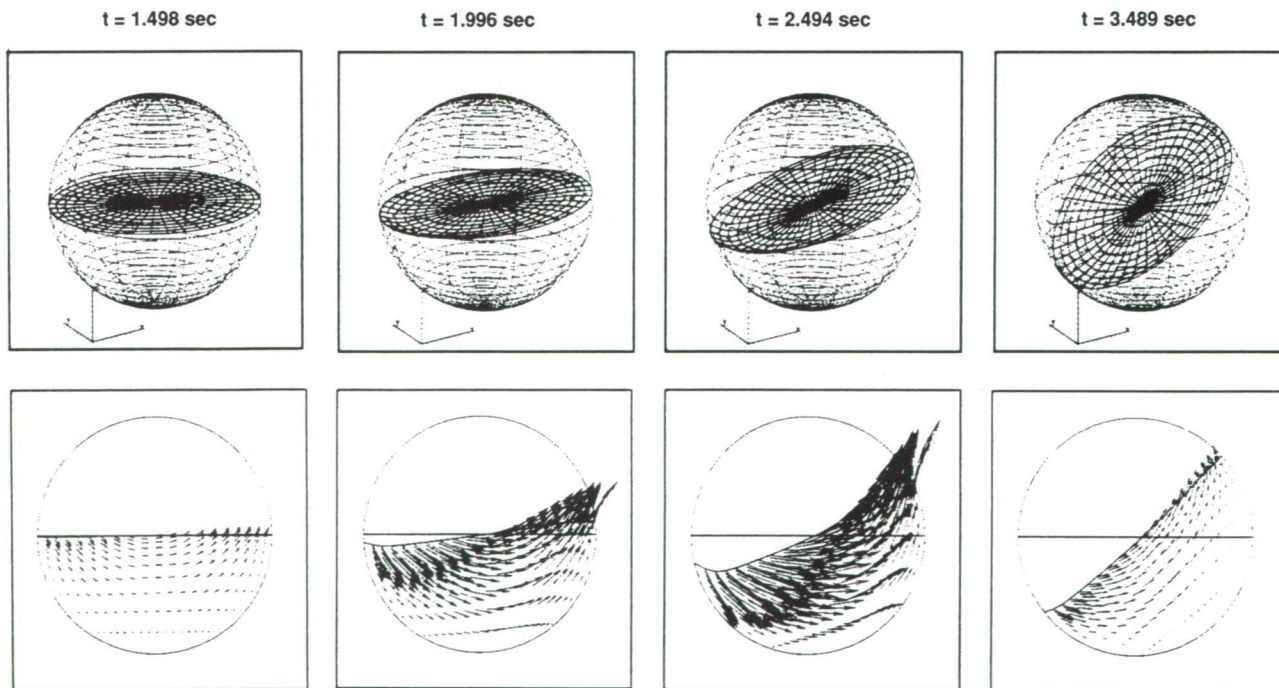

Selected free-surface (top) and velocity-vector (bottom) plots for the orbital spin-up of a spherical tank half filled with glycerine. Steady-state angular velocity = 60 rpm.

# Martian Atmosphere General Circulation

James B. Pollack, Principal Investigator  
Co-Investigator: Robert Haberle  
NASA Ames Research Center

## Research Objective

To simulate the present and past climate regimes on Mars. A general circulation model (GCM) predicts the time-evolving three-dimensional wind and temperature fields and the surface pressure, temperature, and carbon dioxide ice abundance.

## Approach

The Mars GCM is based on the primitive equations of meteorology that are used for terrestrial weather prediction. Uniquely Martian physics, such as the condensation and sublimation of carbon dioxide in the polar region, are incorporated into the Mars GCM. It has been interfaced with an aerosol physics model to simulate the transport of dust by winds and the impact of sunlight absorption by dust on temperatures and winds.

## Accomplishment Description

The life cycle of global dust storms on Mars has been simulated with the coupled GCM/aerosol physics models for several plausible spatial distributions of surface sources of dust. We found that the strong feedback between dust heating and winds plays an essential role in the spreading of the dust from its southern hemisphere to the opposite hemisphere. Eddies, especially transient-baroclinic eddies, enable the dust to travel from northern mid-latitudes to the northern polar region. The results of these simulations are mostly in accord with relevant observations.

## Significance

The seasonal cycle of dust represents an important component of the present climate on Mars since it strongly influences atmospheric temperatures and winds. Understanding the development of global dust storms is an important step toward gaining insight into the factors that determine the amount of dust in the atmosphere and its seasonal and interannual variations.

## Future Plans

A parameterization will be developed for the amount of dust lifted into the atmosphere by surface winds of varying strength and it will be used in fully interactive simulations of the seasonal dust cycle. The Mars GCM will be further developed for data analyses returned by the Mars Observer spacecraft.

## Publications

1. Pollack, J. B.; Haberle, R. M.; Schaeffer, J.; and Lee, H. "Simulations of the General Circulation of the Martian Atmosphere: Part I. Polar Processes." *J. Geophys. Res.* 95 (1990): 1447-1473.
2. Pollack, J. B.; Haberle, R. M.; Murphy, J. R.; Schaeffer, J.; and Lee, H. "Simulations of the General Circulation of the Martian Atmosphere: Part II. Seasonal Pressure Variations." Accepted for publication in *JGR Planets*.

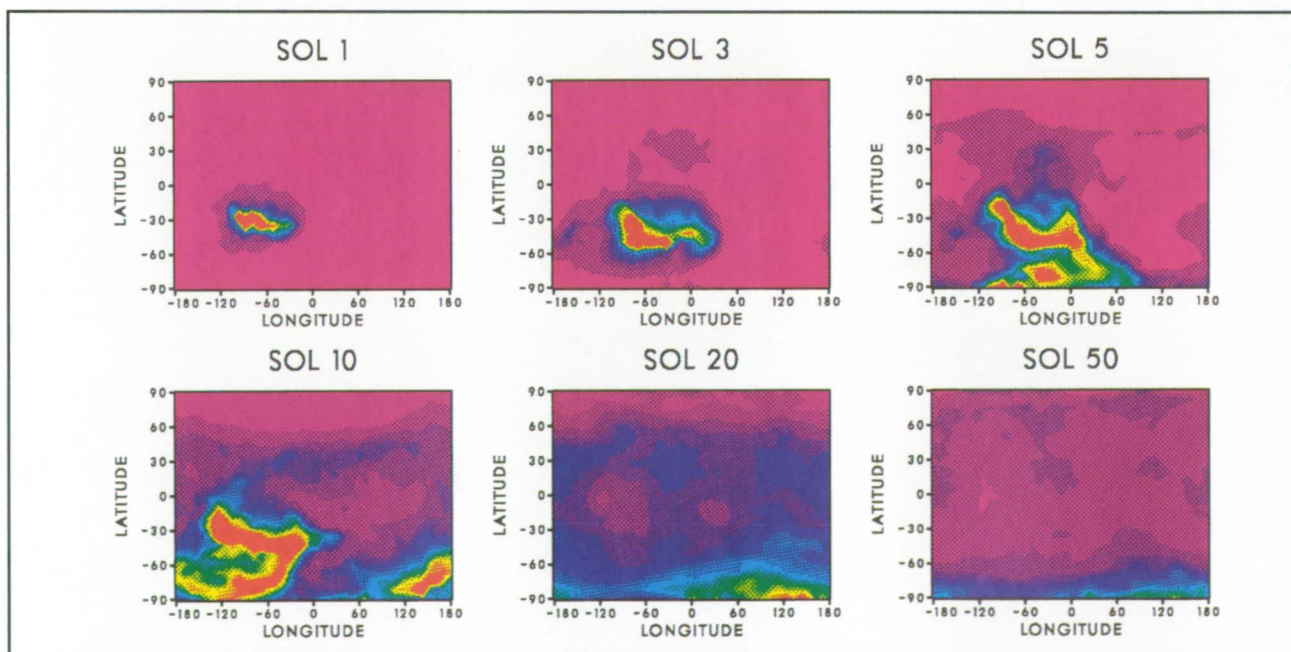

Instantaneous maps of vertically integrated visible dust opacity ( $\tau$ ) at several times from the start of a simulated Martian global dust storm. The prescribed invariant surface dust source persists for 10 sols (sols = number of Mars days). Opacity values increase from magenta ( $\tau < 0.5$ , including 0), violet ( $\tau = 2$ ), blue ( $\tau = 4$ ), green ( $\tau = 6$ ), yellow ( $\tau = 8$ ), to red ( $\tau \geq 10$ ).

# Three-Dimensional Scramjet Combustors

Greg D. Power, Principal Investigator  
Co-Investigator: Thomas J. Barber  
United Technologies Research Center

## Research Objective

To identify mixing-enhancement concepts and simulate the complex three-dimensional interaction effects found in a scramjet combustor using a state of the art Navier–Stokes analysis.

## Approach

The approach was to develop necessary turbulence and kinetics models and then implement them into UTSPARK, a version of the SPARK Navier–Stokes code developed at NASA Langley. The analysis was used to examine the nonreacting and reacting flow from an innovative scramjet-combustor fuel-injection concept.

## Accomplishment Description

As a result of deficiencies identified through numerous validation studies, we developed and implemented into the UTSPARK Navier–Stokes code the two-equation Jones and Launder (k- $\epsilon$ ) turbulence model, including the recent compressibility corrections introduced by Sarkar. The analysis was applied to the mixing rates and combustion efficiency of a combustor fuel-injection scheme utilizing laterally spaced injector struts. The analysis, performed in support of a series of subscale combustor experiments, entailed simulation of the facility plenum nozzle and the test section. Fuel was injected from the sides of the strut

and at an angle to the free stream from the strut tip. The accompanying figure illustrates the strut and the fuel concentration. The test-section calculations, which utilized approximately 200,000 grid points, required approximately 125 megawords of memory and about 75 Cray Y-MP hours. The fuel concentration indicates that the injected fuel is near the lower surface of the facility. Also, while the overall equivalence ratio is sufficient to burn all the fuel, the local equivalence ratio is either near zero or much greater than one, resulting in reduced combustion efficiency.

## Significance

The efficiency of a scramjet combustor is limiting technology in successfully achieving a flyable hypersonic vehicle such as the National Aero-Space Plane. Critical factors influencing the combustor design are the combustor fluid dynamics, rate of heat release, and combustion efficiency. Numerically validated codes represent a viable design technique to augment conventional experimental design approaches.

## Future Plans

Future work on this project has not yet been determined.

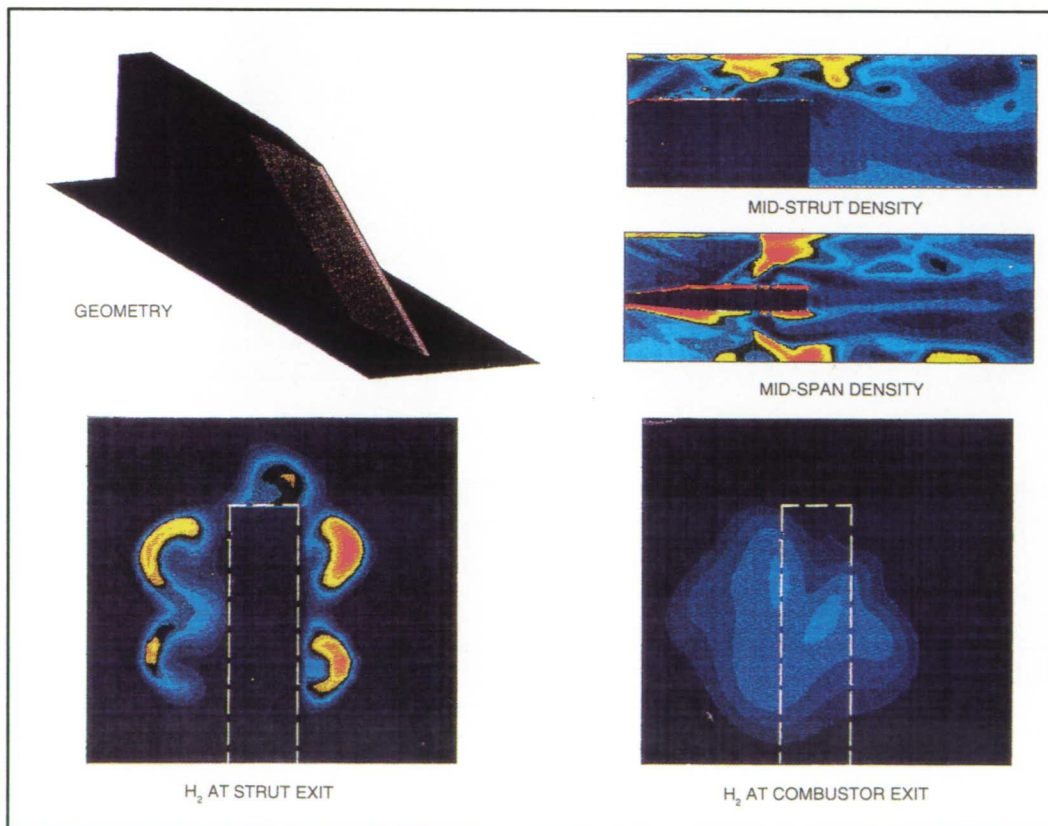

Three-dimensional simulation of a combustor scramjet.

# Hypersonic-Flow Computations using Adaptive Unstructured Meshes

Ramadas K. Prabhu, Principal Investigator  
Lockheed Engineering and Sciences Company/NASA Langley Research Center

## Research Objective

To determine the effects of thermal and chemical non-equilibrium on aerothermal loads experienced by bodies in hypersonic flow.

## Approach

Air is modeled as a reacting mixture of five chemical species having two temperatures—one for the translational-rotational mode, and the other for the vibrational-electronic excitation mode. The governing equations are the mass conservation equations for the five chemical species, the momentum equations, and the two energy equations (one each for total energy

and the vibrational-electronic excitation energy). These are solved using a finite-volume approach and a cell-centered upwind scheme. Unstructured meshes are employed to discretize the computational domain. An existing computer code, LARCNESS, was modified to include these changes from ideal gas to non-equilibrium flows.

## Accomplishment Description

Results were obtained on several problems involving hypersonic flow past blunt bodies. The accompanying figure shows sample results obtained for an inviscid Mach 17.9 flow past a blunt body assuming a single temperature model. Results were obtained for two cases, namely  $r = 1$  mm and  $r = 1$  m. Mach number, temperature distribution, and the mass fraction distributions on the line of symmetry are shown in the figure. These results compared very well with the results of Desideri et al.

## Significance

Air undergoes dramatic compositional changes at the high temperatures encountered in hypersonic flight. Convective ideal-gas or equilibrium-gas assumptions are not valid under these conditions. Multiple species are needed to model the chemical composition and multiple temperatures are required to characterize the energy of air undergoing fast change. This code demonstrates the need for such analysis.

## Future Plans

The computer code is being extended to include the transport terms of viscosity, thermal conductivity, and mass diffusion. The generation of unstructured meshes is also in progress. Several examples of practical interest will be solved, including blunt bodies in hypersonic flow with shock-shock interference configurations.

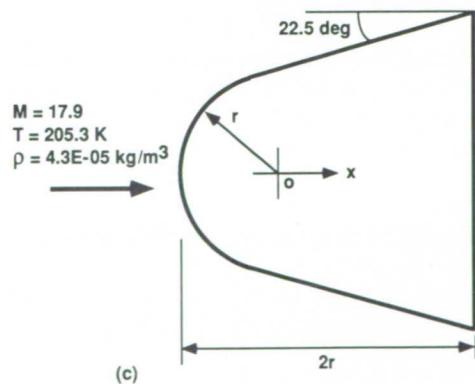
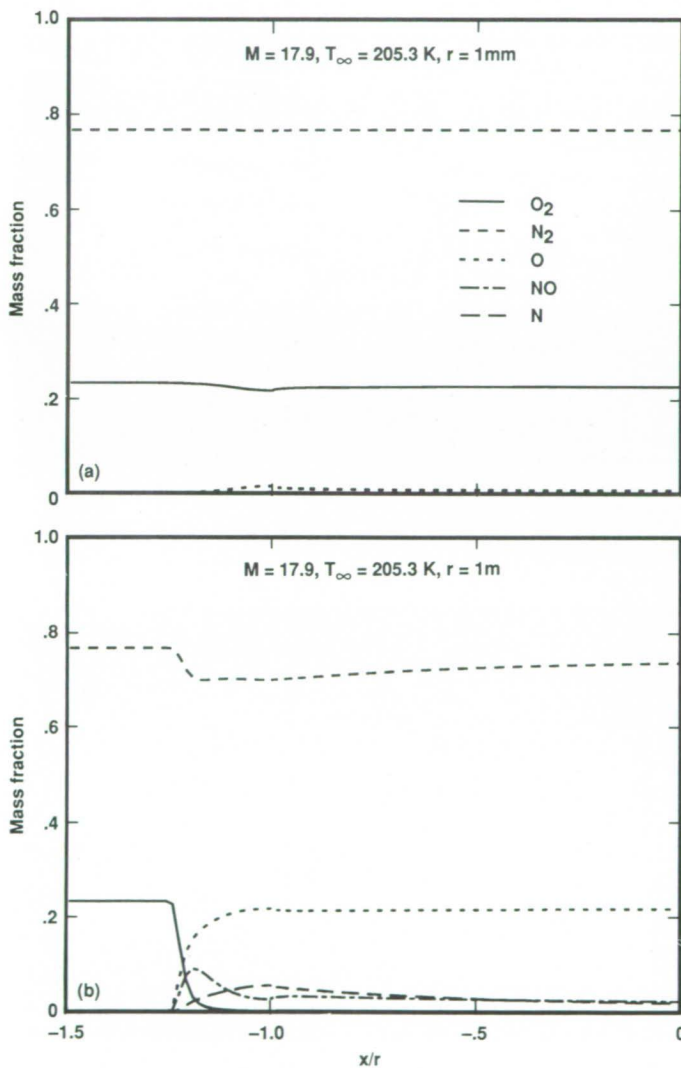

Results obtained for an inviscid Mach 17.9 flow past a blunt body. (a) Mass fraction distribution; Mach = 17.9,  $T_\infty = 205.3$  K,  $r = 1$  mm. (b) Mass fraction distribution; Mach = 17.9,  $T_\infty = 205.3$  K,  $r = 1$  m. (c) Problem statement.

# Laminar Breakdown of High-Speed Boundary-Layer Flow

C. D. Pruett, Principal Investigator

Co-Investigator: T. A. Zang

Analytical Services and Materials, Inc./NASA Langley Research Center

## Research Objective

To computationally examine the physics governing the transition of high-speed compressible boundary-layer flows from ordered (laminar) to chaotic (turbulent) states.

## Approach

A variety of computational tools have been applied to the problem, including direct numerical simulation (DNS), “adulterated” numerical simulation (ANS), large-eddy simulation, and secondary instability theory (SIT).

## Accomplishment Description

Long-duration temporal DNS computations from initial states derived from SIT reveal that the (0,2) Fourier harmonic, not present in the initial condition, eventually dominates all other harmonics in energy content—a result not anticipated by the investigators. Subsequent review of recent scientific literature revealed that other researchers also observed and reported the dominance of modes of purely spanwise wave number that are associated with streamwise vorticity. In DNS, the energy content of selected harmonics can be monitored precisely and, if desired, controlled. In this spirit, the ANS was conducted with the (0,2) mode artificially suppressed. The resulting flow fields of the DNS and ANS computations are compared in the accompanying figures for a Mach 4.5 boundary-layer flow on a hollow cylinder. In the DNS computation, the highly three-dimensional flow shown at dimensionless time ( $T$ ) 45 soon experiences laminar breakdown commensurate with saturation of the (0,2) harmonic at large amplitude at about  $T = 50$ . In contrast, suppression of the (0,2) mode dramatically reduces the three-dimensionality of the flow field in the ANS, completely inhibiting laminar breakdown. Because relatively coarse resolution sufficed in the ANS in the absence of laminar breakdown, roughly 120 Cray-2 hours and 5 megawords of memory were used—substantially less than the original DNS.

## Significance

The results of the ANS are potentially profound and suggest that, rather than focusing on the roles of primary and secondary instability mechanisms as in the past, transition research should perhaps focus on the role played by streamwise vorticity.

## Future Plans

The temporal DNS that forms the core of this work is presently being recast in the context of the more physically correct (but computationally intensive) spatial stability theory, in which disturbances evolve in space rather than in time.

## Publications

1. Pruett, C. D. and Zang, T. A. “Direct Numerical Simulation of Laminar Breakdown in High-Speed, Axisymmetric Boundary Layers.” To be published in *Theoretical and Computational Fluid Dynamics*, 1992.
2. Ng, L. L. and Zang, T. A. “Secondary Instability Mechanisms in Compressible, Axisymmetric Boundary Layers.” AIAA Paper 92-0743, 1992.
3. Kral, L. D. and Zang, T. A. “Large-Eddy Simulation of Supersonic, Wall-Bounded Turbulent Flows.” In *ICASE/LaRC Workshop on Transition and Turbulence*, ed. M. Y. Hussaini. New York: Springer, 1992.

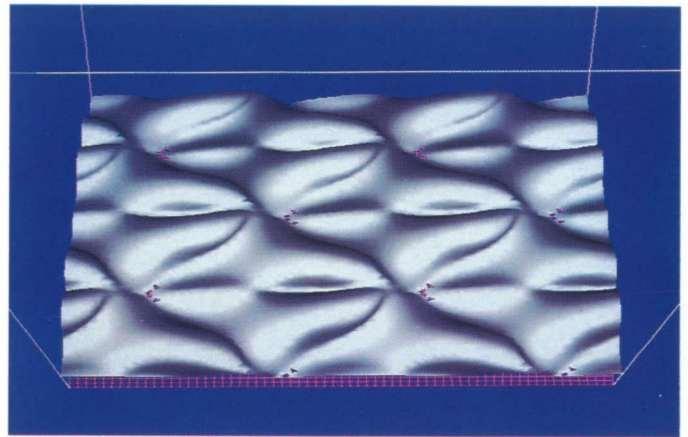

Surfaces of constant streamwise velocity at  $T = 45$ ; direct numerical simulation.

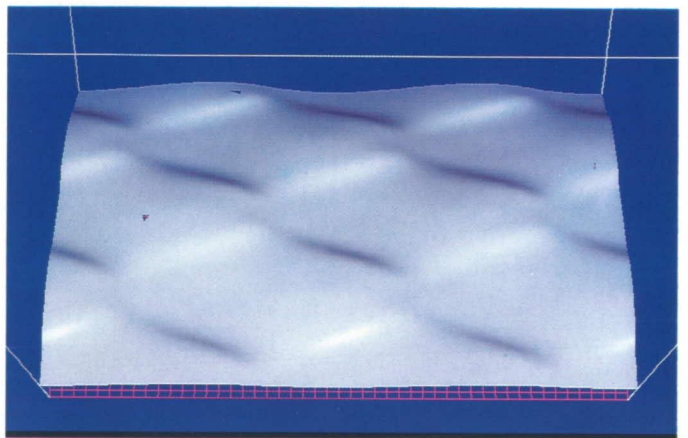

Surfaces of constant streamwise velocity at  $T = 45$ ; “adulterated” numerical simulation.

# Shock Impingement in Hypersonic Engine Inlets

R. Ramakrishnan, Principal Investigator  
NASA Langley Research Center

## Research Objective

To study the effect of shock impingement on aerothermal loads in an axial corner simulating a hypersonic engine inlet using a three-dimensional dynamic grid-adaptation procedure.

## Approach

A three-dimensional Navier–Stokes code, SCRAMAD, is utilized to predict the complex flow features associated with shock impingement on an asymmetric axial corner. The code includes a three-dimensional dynamic adaptation procedure that is based on the concept of spring-mass systems to adapt the finite-difference grid to regions of strong gradients. The adaptation procedure uses a linear combination of spatial derivatives of select flow variables to relocate the grid points. Laminar and turbulent Mach 6 flow in the corner are analyzed and compared to experimental results.

## Accomplishment Description

The three-dimensional flow features associated with shock impingement on a hypersonic engine inlet has been investigated for both laminar and turbulent flows. The overall flow features and heat transfer rates predicted by the numerical analysis are in good agreement with experimental observations. The accompanying figure shows the interactions of the oblique shock from the forebody with the cowl surface.

## Significance

The three-dimensional grid adaptation procedure is capable of handling highly stretched grids that are prevalent in hypersonic viscous flows and the procedure does not encounter problems due to grid crossover. The coupling of the grid adaptation procedure to the Navier–Stokes solver makes it possible to analyze three-dimensional hypersonic flow problems without the need for a prohibitive number of grid points. The grid adaptation procedure used ensures adaptation to multiple shocks and ensures good definition of the thin hypersonic boundary layer.

## Future Plans

Efforts are under way to increase the efficiency of the adaptation procedure, investigate grid adaptation measures, and use the computational procedure to analyze other three-dimensional problems involving complex shock/shock and shock/boundary-layer interactions.

## Publication

Ramakrishnan, R. "Numerical Simulation of Aerothermal Loads in Hypersonic Engine Inlets due to Shock Impingement." AIAA Paper 92-2605, AIAA Applied Aerodynamics Conference, Palo Alto, CA, 1992.

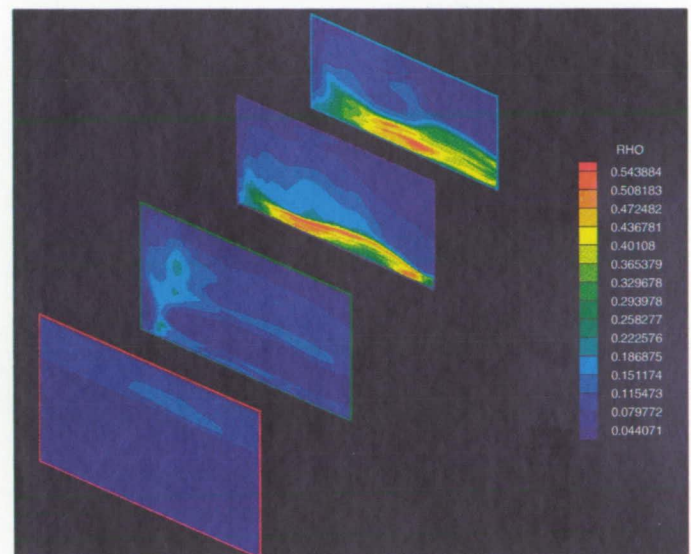

*Interactions of the oblique shock from the forebody with the cowl surface.*

# Complex Three-Dimensional Flows in the Advanced Solid-Rocket Motor

Edward J. Reske, Principal Investigator  
Co-Investigators: Dana F. Billings and Joni W. Cornelison  
NASA Marshall Space Flight Center

## Research Objective

To characterize the internal flow environment in the advanced solid-rocket motor (ASRM). Three-dimensional computational fluid dynamics (CFD) models are tools in addressing key design issues.

## Approach

A three-dimensional Navier–Stokes flow solver has been used to analyze complex flows in the aft end segment and nozzle of the ASRM. Input on physical reference quantities and boundary conditions were obtained from the JANNAF Solid Performance Prediction ballistics program.

## Accomplishment Description

Preliminary two-dimensional axisymmetric analyses were performed with the Navier–Stokes codes CMINT and FDNS3D. An immediate concern has been the prediction of hinge torque moments and loads produced by the internal pressure field acting on a gimballed nozzle; such a problem is inherently three-dimensional. The FDNS3D code was chosen for the three-dimensional analyses. Three-dimensional  $220 \times 64 \times 26$  grids were formed for various burn times and nozzle gimbal angles by rotating a two-dimensional, axisymmetric template grid about its centerline in 26 planes, and then gimbaling the nozzle about its pivot point. We considered

cases for the ASRM at burn times of 19 and 115 seconds, each with gimbal angles of 4 and 8 degrees. Similarly, a comparative study was made for the redesigned solid rocket motor (RSRM) at burn times of 19 and 114 seconds, each at a gimbal angle of 4 degrees. Each three-dimensional solution required 20 Cray Y-MP hours and 16 megawords of memory.

## Significance

These calculations will provide a useful tool in the design of the ASRM. The centers of pressure for the ASRM and RSRM nozzles are far upstream from the nominal pivot points, thus creating non-restoring hinge torque moments in both motors, and the loads and moments acting on the ASRM nozzle are well below those of the RSRM. This could save millions of dollars in the ASRM project because existing RSRM actuators could be used on the ASRM. The results show that the ASRM nozzle performs well in straightening the flow and aligning the thrust vector with the nozzle axis of symmetry.

## Future Plans

CFD analyses addressing grid sensitivity, the effect of inhibitor failures, vortex shedding on the the star grain, code validation by direct comparison with subscale cold-flow test data, and two-phase flow will be performed.

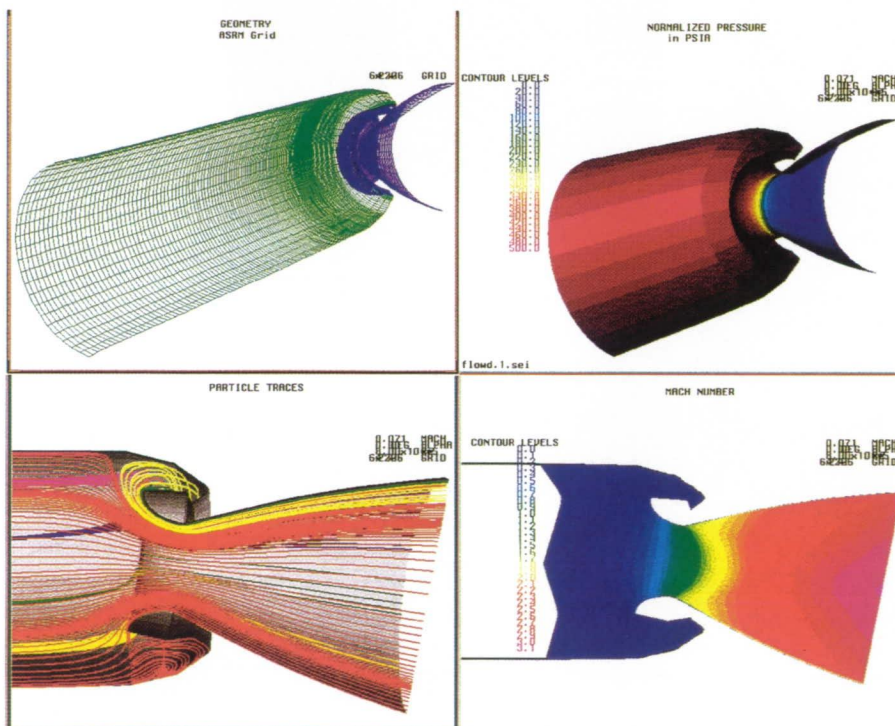

Grid, wall-pressure contours, particle traces, and Mach-number contours for the ASRM at the 115 second burn time with an 8 degree gimbal angle.

# Leading-Edge Heat Transfer in a Flow with Spanwise Variations

David L. Rigby, Principal Investigator  
Sverdrup Technology, Inc.

## Research Objective

To investigate the interaction of free-stream vorticity with the stagnation region of a leading edge. The effect on leading-edge heat transfer is of particular interest. Results of this research should improve the understanding of the mechanism by which free-stream turbulence causes the heat transfer to increase.

## Approach

The three-dimensional Navier–Stokes equations are solved using the PARC3D code. A periodic spanwise variation in velocity is imposed upstream from the body. On the body surface, either uniform wall heat flux or uniform wall temperature is imposed.

## Accomplishment Description

Using the PARC3D code, flow over a blunt flat plate with a 3:1 elliptical leading edge has been studied. A steady spanwise velocity profile was imposed upstream from the leading edge. As expected, for equivalent conditions, the circular leading edge has a higher heat-transfer coefficient than the ellipse. As a ratio to the corresponding result with no spanwise variation, the circle and ellipse show similar increases in most cases. Increases in the heat-transfer coefficient on the order of 20% were seen with upstream spanwise velocity variations as low as 5%. On

average, each case required approximately 10 Cray-2 hours and 10 megawords of memory.

## Significance

Accurate prediction of surface heat transfer is essential in the design of efficient and reliable turbomachines. The heat transfer in the stagnation region is sensitive to low levels of turbulence and this study indicates the stagnation-region heat transfer is also sensitive to small spanwise variations in the mean free-stream velocity. The connection between the previous two observations is not clear. The mechanism studied in this work may begin to explain how low levels of turbulence can cause large increases in heat transfer, since at any instant in time a turbulent flow will have spanwise variations.

## Future Plans

Additional calculations will be run on a 2.25:1 and a 1.5:1 elliptical leading edge. Experimental results will be compared to the calculations. Upon completion of the steady calculations, an investigation of the effect of unsteadiness on this mechanism will begin. To do the unsteady calculations, other numerical codes may need to be used.

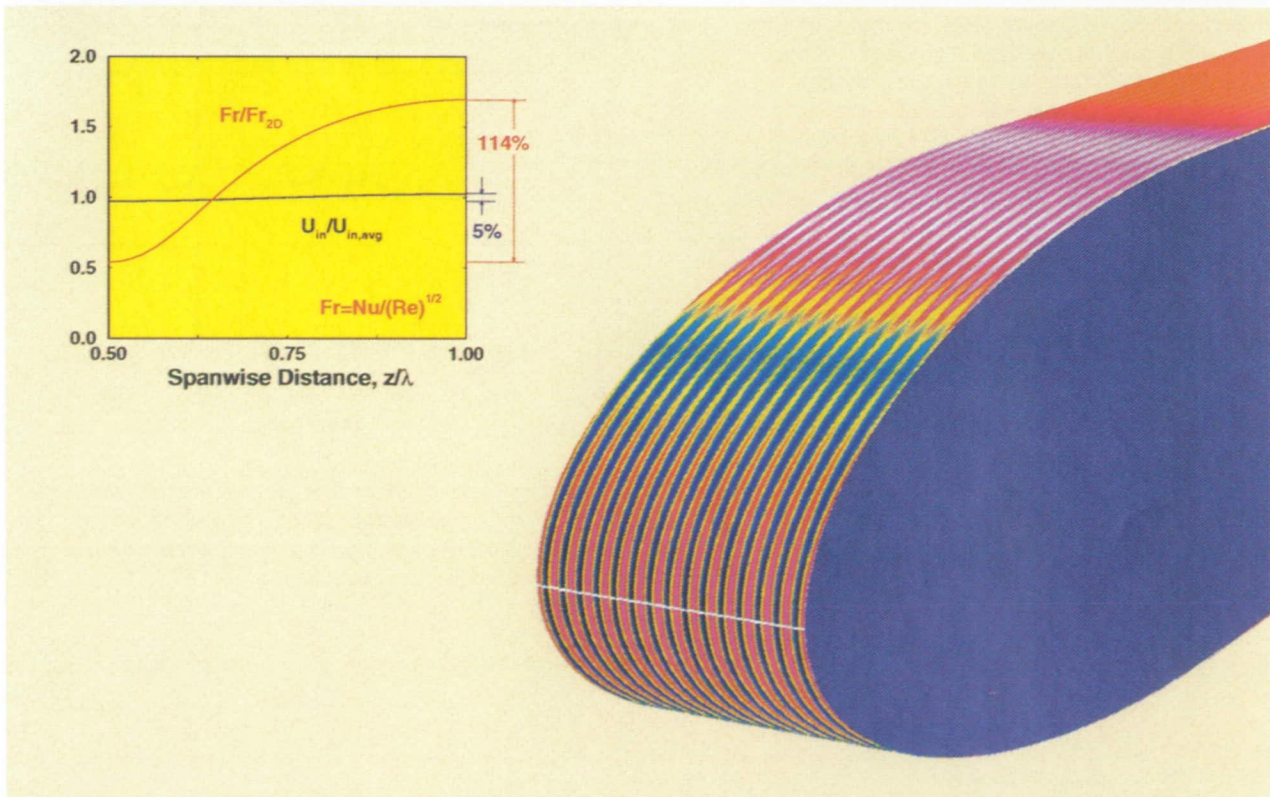

A 3:1 elliptical leading edge with spanwise variation in velocity. The surface shows the heat transfer coefficient (red = high, blue = low). Reynolds number = 25,000, based on leading edge diameter. Spanwise wavelength = 0.1  $D$ .

# Scattering from Ocean Surfaces and Near-Surface Objects

Charles L. Rino, Principal Investigator

Co-Investigators: Hoc D. Ngo, Thomas L. Crystal, and Carl E. Hess  
Vista Research, Inc.

## Research Objective

To develop a capability to simulate the scattering of electromagnetic frequency, acoustic frequency, and light from dynamically evolving nonlinear ocean surfaces and near-surface objects.

## Approach

Direct numerical solutions to the surface-boundary integral equations remain impractical for realistic problems. However, as an extension of our work with multiple scattering between an object and a nearby rough surface, we have been exploring various techniques to segment the surface and coherently combine the subsolutions. If multiple scattering between the subsegments is ignored, we obtain the beam simulation technique. Bad experiences have forced us to use careful benchmarking.

## Accomplishment Description

Previously, we had developed a family of codes that could numerically solve the surface-boundary value problem and the mutual interaction of an object near the rough surface. More recently, we have begun to explore scattering at near-grazing incidence, thus requiring progressively longer surfaces. To succeed at 5 degrees incidence, simulated surfaces require nearly 4,000 points and the scattering simulation needs to invert a 4,000-square complex matrix. This barely fits into the 32 megaword queue (closer to grazing cases, for any significant roughness, we would move into the special queues). Coding optimization has reduced run times to 15 minutes, and the inversion is usable for simulating several incidence angles. Unfortunately, for proper statistics of rough-surface scattering, 10–20 independent realizations are necessary. Then the whole parameter set must be repeated at different wind speeds for different roughnesses.

## Significance

Both theory and numerical simulations have failed to satisfactorily address the grazing incidence problem. Even the small perturbation theory fails as strict grazing incidence is approached. Both the accuracy and the size of the surface needed to sustain resolution at small grazing angles cause problems. The beam simulation method, with corrections for multiple scattering, may provide a way to simultaneously increase numerical accuracy and resolution within practical computation limits.

## Future Plans

We will continue to develop and test the methods with one-dimensional simulations and, as encouraging results emerge, the method will be extended to two-dimensional surfaces.

## Publications

1. Rino, C. L.; Crystal, T. L.; Koide, A. K.; Ngo, H. D.; and Guthart, H. "Numerical Simulation of Acoustic and EM Scattering from Linear and Nonlinear Ocean Surfaces." *Radio Science* 26, no. 1 (1991): 51–71.
2. Rino, C. L. and Ngo, H. D. "Low-Frequency Acoustic Scatter from Subsurface Bubble Clouds." *J. Acoust. Soc. Am.* 90, no. 1 (1991): 406–415.

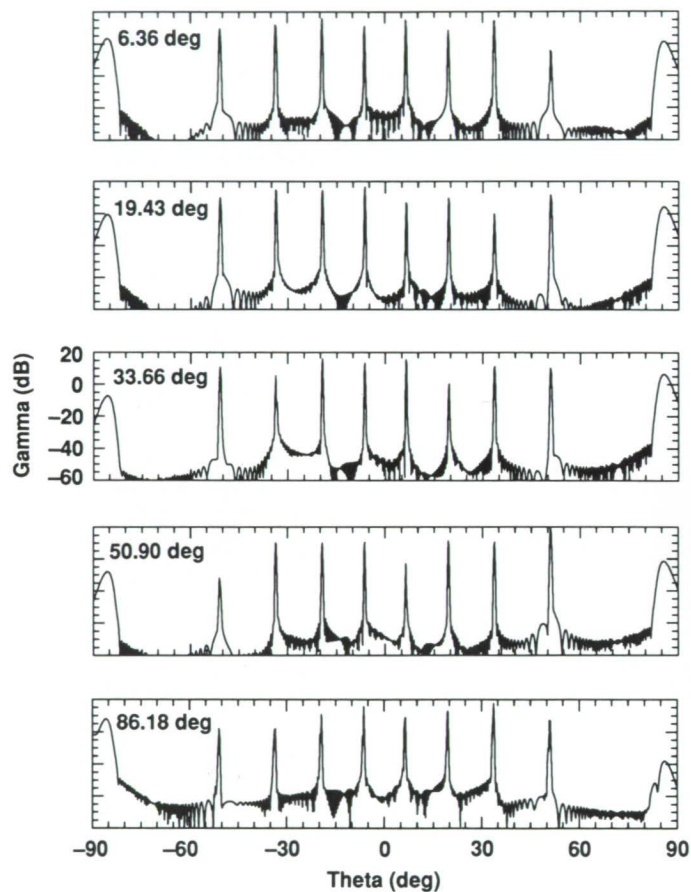

Simulation of a sinusoidal diffraction grating. Incident illumination is applied at each diffraction order. The grating lobe at 86.18 degrees is just resolved as the incident illumination is brought inside of 5 degrees from grazing.

# Jet Interaction Aero-Optic Effects on Hypersonic Interceptors

R. P. Roger, Principal Investigator  
Co-Investigator: S. C. Chan  
Teledyne Brown Engineering

## Research Objective

To obtain flow-field predictions for missile control jet-configurations that could adversely affect the performance of an on board infrared (IR) seeker. Computed solutions will provide input to a wave optics aero-optic code which predicts the influence of the flow field on a target signal at the seeker focal-plane array. Configurations of concern include lee-side firing of center of gravity (CG) thrusters at large angles of attack and firings at high altitude.

## Approach

A three-dimensional full Navier–Stokes flow solver employing an upwind algorithm is being used to predict the complex jet interaction (JI) flow field for advanced defense-interceptor concepts. Initially, computational fluid dynamics results are generated for wind tunnel test conditions to compare with test data (force and moment, surface pressure and temperature, and Schlieren photographs). As a result, projected tactical flight conditions will be simulated.

## Accomplishment Description

One configuration is triconic with a single flat slot-cooled seeker window. A computational grid, modeling the window tetraconic forecone section and the mid and aft cone sections containing the CG thruster, has been constructed. The two sections are 1.5 and 2.0 million grid points, respectively. A computational grid for a monoconic design containing about two-thirds as many grid points was also constructed. Computed results for the slot-cooled triconic forebody compare well with surface pressure and temperature distribution data. Computed results for the triconic thruster firing at 0 and 15 degree angles of attack also compared well to force and moment data and to Schlieren photographs. A grid resolution study was required to ensure accurate predictions for the extent of the recirculation region upstream from the jet. The tunnel JI cases did not include the slot-cooled window and incorporated 2.5 million grid points. The 0 degree case was performed in three computational blocks. It required 110 Cray Y-MP hours and 52 megawords of memory for the largest block.

## Significance

Almost all proposed designs for advanced endo-atmospheric interceptor concept development employ IR seekers and CG thrusters. Use of CG lateral control during “end game” is preferred because of the reduced sensitivity to target miss distance. For maneuvering target intercepts, large lee-side angles of attack are possible. Wind tunnel tests indicate that the jet upstream recirculation region could extend onto the seeker window. We are investigating this phenomenon using our computations.

## Future Plans

Tactical flight-environment predictions and the incorporation of a transpiration-cooled mosaic-window biconic construction are planned.

## Publication

Chan, S. C. and Roger, R. P. “Numerical Study of the Complex Flow-Field Features for a Supersonic Jet Exiting Normal to a Supersonic Stream.” AIAA Paper 92-3675, July 1992.

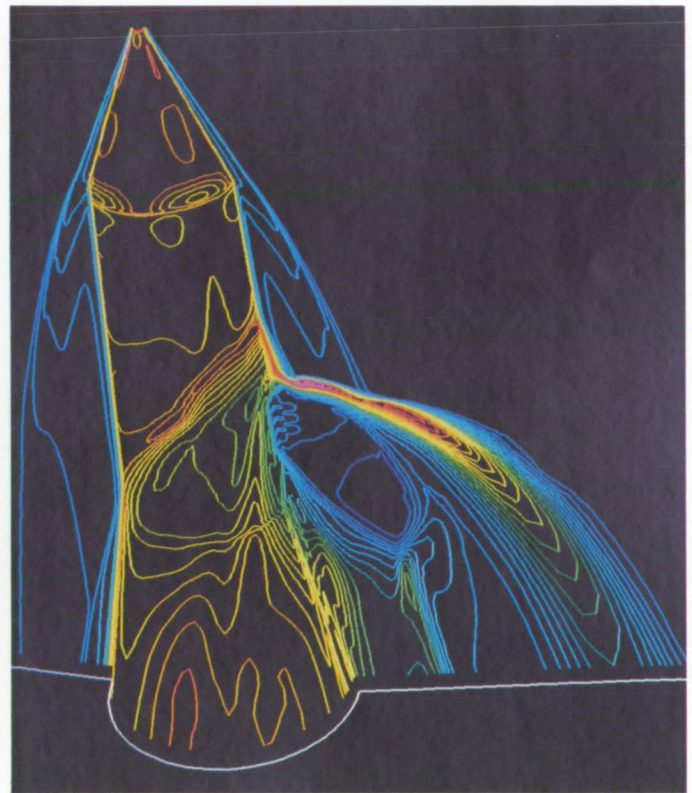

Surface and symmetry plane temperature contours at 0 degree angle of attack for a tetracone triconic configuration (nosetip blocked out).

# Mixing and Reacting in Plane Mixing Layers

Michael M. Rogers, Principal Investigator

Co-Investigators: Robert D. Moser, S. Scott Collis, and Chris Rutland

NASA Ames Research Center/Stanford University/University of Wisconsin, Madison

## Research Objective

To generate a direct numerical simulation (DNS) data base for reacting turbulent mixing layers to aid in the study of combustion.

## Approach

We will focus on the low-heat-release limit of reaction in incompressible turbulence using DNS of the full three-dimensional Navier–Stokes equations with resolution adequate to resolve both the turbulence and the flame zone. Early work is based on reacting passive scalars in an incompressible turbulence using pseudo-spectral numerical methods. The mixing layers examined evolve temporally in an infinite cross-stream domain.

## Accomplishment Description

A fully turbulent mixing-layer simulation with a visual thickness Reynolds number of up to 15,000 has been simulated. The simulation was begun from numerically simulated turbulent boundary layers with no additional disturbances. As the layer thickens in time, more computational modes are added in the cross-stream direction. Currently, the simulation uses  $512 \times 210 \times 192$  modes (with  $3/2$  times as many physical space mesh points in each direction for de-aliasing of the nonlinear terms). Each sub-step takes 570 Cray-2 seconds and 140 megawords of memory. To date, the simulation has required 750 Cray-2 hours. The streamwise one-dimensional

velocity spectrum exhibits nearly a decade of inertial range ( $k^{-5/3}$  spectrum). Much of the vortex structure of the flow is similar to that of previous simulations begun from “clean” initial conditions, and the study of such “prototypical” flows is expected to aid in the understanding of this more complicated, fully developed turbulent case. A fast-reaction, low-heat-release diffusion flame is shown in the accompanying figure. The top three frames show side views of the layer at three different times. The clumping of product in “rollers” with high gradients in the “braid” regions is apparent. The bottom two frames show end views of the reaction product at the final time shown in the third side view. Mushroom structures of the kind observed in experiments are visible. At this point, the layer is evolving self-similarly.

## Significance

This simulation is the first turbulent free-shear-flow DNS begun from realistic turbulent inlet and initial conditions and is the first to achieve self-similarity. The mixing layer has the highest Reynolds number of this flow ever achieved by DNS and is the only such simulation to exhibit an inertial range.

## Future Plans

We will continue post-processing of the simulation and study the effects of reduced chemical-reaction rate.

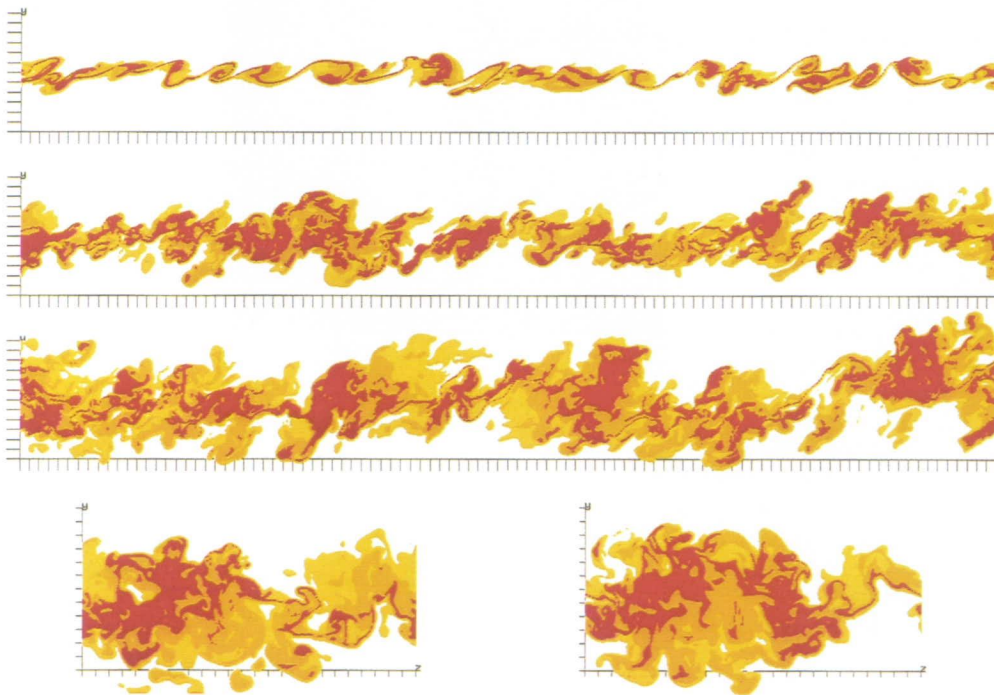

Product concentration (red = high and yellow = low) of a fast, low-heat-release diffusion reaction in a turbulent-plane mixing layer. The top three frames show a particular spanwise location at three different times and the bottom two show end views at different streamwise locations at the last time shown.

# Hypervelocity Mixing and Combustion in Pulse Facility Flows

R. Clayton Rogers, Principal Investigator

Co-Investigators: David W. Riggins, Robert D. Bittner, and Glenn J. Bobskill

NASA Langley Research Center/University of Missouri, Rolla/Analytical Services and Materials, Inc.

## Research Objective

To determine the fluid dynamic characteristics and performance of hypersonic scramjet combustors, and to develop methods to accurately predict the combustor flow field and performance. In addition, we will study whether (1) flight Mach number affects combustor performance, (2) low-enthalpy fuel mixing simulations accurately represent fuel mixing in a scramjet combustor, and (3) ground-based test results represent flight performance.

## Approach

Because of difficulty in measuring scramjet combustor performance directly, numerical solutions are performed to compare with limited measurements and are then used to predict combustor performance. Measurements used for comparison include wall pressure and heat flux, shadowgraphs, holograms, planar laser-induced fluorescence of hydroxyl, and laser absorption measurements of hydroxyl.

## Accomplishment Description

Numerical and experimental results have been compared for several "unit" configurations with either one or two fuel injectors. Injector configurations studied include circular discrete flush-wall injectors, and swept and unswept ramp injectors. Numerical results compare favorably with the limited experimental measurements, providing confidence in the solutions. The current numerical solutions have been compared to experimental and other numerical solutions for both (1) lower Mach number tests and (2) low-enthalpy simulation (cold flow mixing at the same combustor Mach number) of the same configurations. A numerical flight-scaling methodology was developed and applied, including the effect of test pressure, temperature, test gas contaminants, and geometric scale in an incremental fashion. A typical job requires 20 megawords of memory and is run in 2-4 hour segments.

## Significance

These computational studies, in conjunction with the high-enthalpy experimental data, represent the first comprehensive examination of hypersonic scramjet combustor performance. Good comparison with experimental data indicates that turbulence models developed for lower Mach numbers are reasonably accurate at these very high Mach numbers. The accompanying figure illustrates a numerically generated flow field for a Mach 13.5 combustor with a swept ramp injector. Comparisons of experimentally backed numerical solutions demonstrate significant shortcomings in the simulation of combustor fuel mixing utilizing Mach similarity without accounting for velocity differences. Therefore, as shown in the figure, methods of scaling were developed to account for differences between low- and high-enthalpy fuel mixing.

## Future Plans

We will perform numerical sensitivity studies to determine the adequacy of experimental parameters that were measured to validate numerical models.

## Publication

Riggins, D. W. and McClinton, C. R. "A Computational Investigation of Mixing and Reacting Flows in Supersonic Combustors." AIAA Paper 92-0626, Jan. 1992.

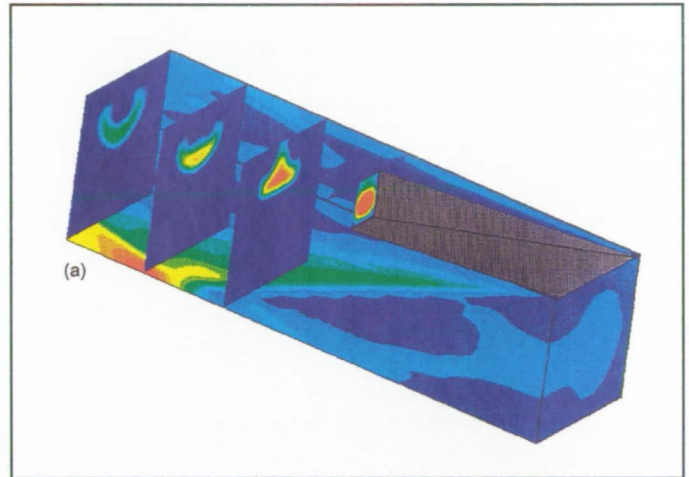

Hydrogen-mass fraction contours on a swept ramp injector base and three downstream cross-flow planes; pressure contours on inflow plane, symmetry plane, and bottom wall. For both parameters, red = high values and blue = low values.

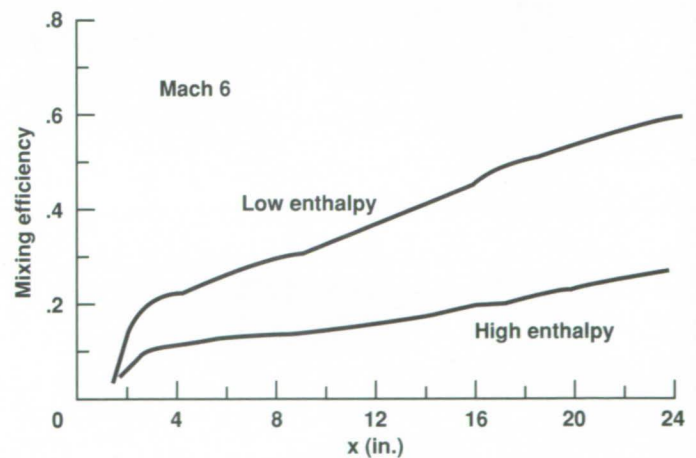

Effect of combustor velocity on fuel mixing.

# Hypersonic Inlet Flow Fields

William C. Rose, Principal Investigator  
NASA Ames Research Center

## Research Objective

To design aerodynamic contours for a potential wind tunnel and flight-test inlet that has flow fields typical of those expected to occur on hypersonic, air-breathing vehicles.

## Approach

We will use the two- and three-dimensional full Navier–Stokes (FNS) internal flow codes run on the Cray-2 and Cray Y-MP. Multiple runs were made with the two-dimensional code to parametrically determine an aerodynamic design capable of operating at flight conditions at Mach numbers of 10 and 15. Several runs with the two-dimensional code were carried out in determining a suitable set of two-dimensional contours. These contours were then assumed to apply to a full three-dimensional symmetrical inlet with a sidewall swept from the ramp leading edge to the cowl lip. The flight-test parameters are those for the proposed NASA Hypersonic Flight Experiment. For these conditions a variable gamma was used, but no other real-gas considerations were invoked. The wind tunnel conditions were appropriate for the NASA Ames 3.5-Foot Hypersonic Wind Tunnel. Each three-dimensional job was run in a series of smaller steps, with each step taking approximately 2 hours and 40 megawords of memory.

## Accomplishment Description

Solutions were obtained for the Mach 15 configuration and one off-design Mach 10 case using the two-dimensional FNS code

and grid dimensions of  $301 \times 81$ . Mach number contours from the two-dimensional flow field at Mach 15 are shown in the accompanying figure. Because of the high dynamic pressure (about 7,000 psf) for one of the proposed flight trajectories, the structural loads on an inlet are significant. The maximum internal pressure loads occur when the inlet unstarts. The time-accurate two-dimensional FNS code was run with downstream boundary conditions simulating an over pressurization of the combustor, causing the inlet to unstart. The surface pressure time histories on the ramp and cowl are shown in the figure inset. A large transient pressure rise is predicted. Approximately 350 hours of single processor CPU time were used in the study.

## Significance

This study has demonstrated the applicability of the two-dimensional FNS code to determine aerodynamic contours for a Mach 15 inlet in order to properly account for large viscous effects. The time-accurate calculated-unstart transient pressure rise indicates that very large structural loads will occur.

## Future Plans

The two- and three-dimensional FNS codes will be used to solve other three-dimensional inlet flow fields applicable to generic hypersonic vehicles.

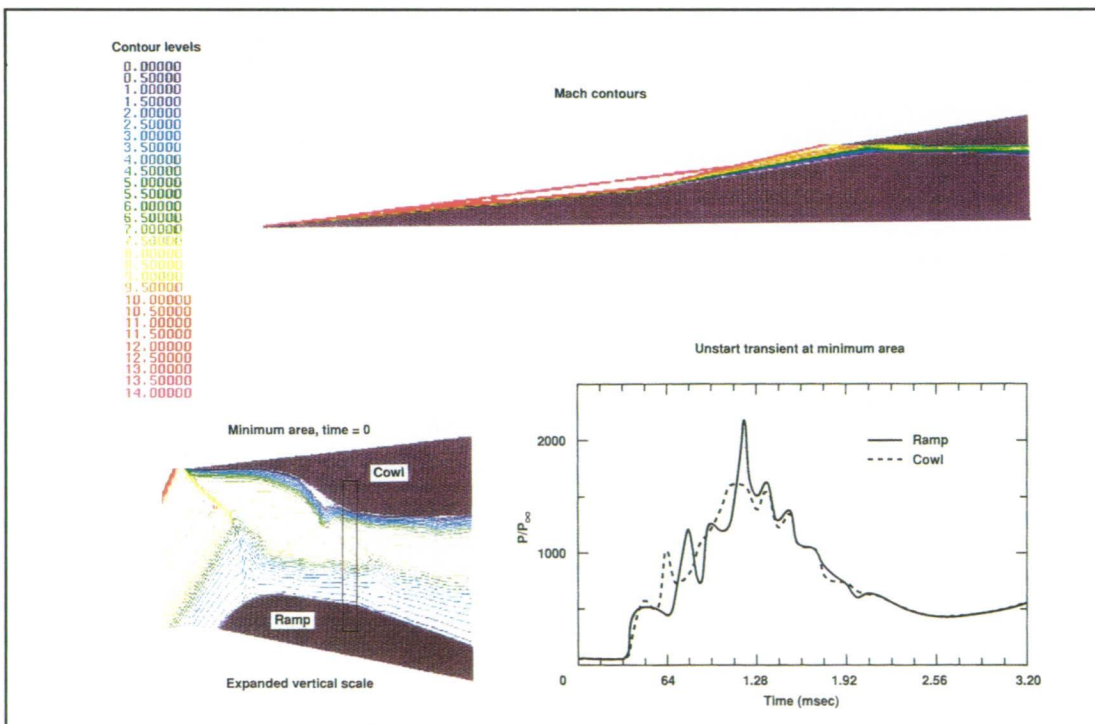

(a) Hypersonic Flight Experiment Mach 15 inlet contours. (b) Expanded vertical scale. (c) Unstart transient at minimum area.

# National Aero-Space Plane Inlet Boundary-Layer Control

William C. Rose, Principal Investigator  
NASA Lewis Research Center

## Research Objective

To compute inlet flow fields with novel boundary-layer control simulations.

## Approach

We used the multiblock three-dimensional full Navier–Stokes code on the Cray-2 and Cray Y-MP with the boundary conditions applied to an inlet surface representative of those expected to occur from porous surfaces and surfaces with portions removed. Each three-dimensional job was run in a series of smaller steps with each small step taking approximately 2 hours and using 40 megawords of memory.

## Accomplishment Description

The multiblock version of the SCRAM3D code was used to examine the nature of boundary-layer control as it applies to the sidewall vortical feature developed as a result of the swept multiple-shock-wave interactions with the sidewall boundary layer occurring in the Mach 5 National Aero-Space Plane (NASP) inlet. Conditions representative of those that occur in the NASA Lewis 10- by 10-Foot Supersonic Wind Tunnel were run. Calculations were carried out through the inlet throat, including a normal shock wave. The accompanying figure shows calculated Mach number contours to a station downstream from the throat. These contours indicate the persistence of the sidewall vortical feature throughout the inlet, so that the best control of the feature is either to not let it develop (cut away sidewalls) or to let it spill overboard (notched cowl surface). Approximately 540 Cray-2 single processor hours were used.

## Significance

The multiblock code has been validated for the complex three-dimensional viscous-flow interactions between the captured internal flow and the external flow field that spilled over the sidewalls and cowl lip. As a result of this computation, modifications to the wind tunnel model have been made to improve inlet performance and these modifications are being tested in a second wind tunnel entry at NASA Lewis.

## Future Plans

The code will be used to investigate three-dimensional flow fields of interest generated in the second wind tunnel entry.

## Publication

Rose, W. "Innovative Boundary Layer Control Methods in High-Speed Inlet Systems—Final Report, Phase II." Prepared for NASA Lewis, Contract NAS3-25783, Nov. 1991.

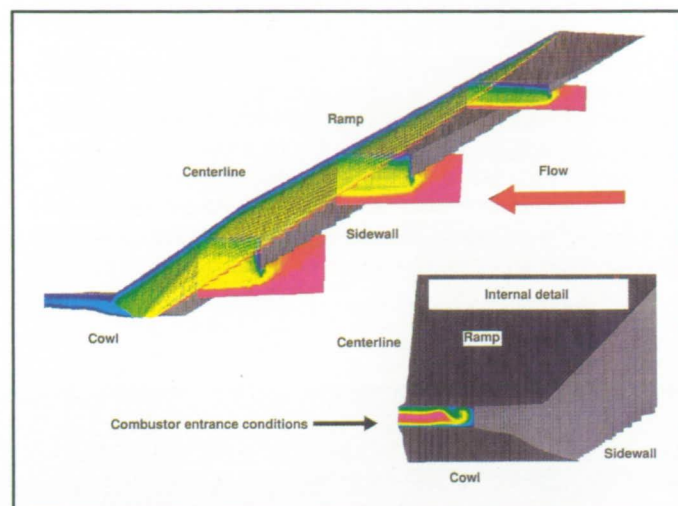

*Mach 10 hypersonic inlet.*

# National Aero-Space Plane Inlet Flow Fields

William C. Rose, Principal Investigator  
NASA Ames Research Center

## Research Objective

To design aerodynamic contours for a wind tunnel test inlet model that has flow fields typical of those expected to occur on hypersonic air-breathing vehicles.

## Approach

We used two- and three-dimensional full Navier–Stokes (FNS) internal flow codes on the Cray-2 and Cray Y-MP. Multiple runs were made with the two-dimensional code to parametrically determine an aerodynamic design capable of operating at conditions for the NASA Ames 3.5-Foot Hypersonic Wind Tunnel at Mach numbers of 10, 7.2, and 5. Several runs with the two-dimensional code were assumed to apply to a full three-dimensional symmetrical inlet with a sidewall swept from the ramp leading edge to the cowl lip. The multiblock three-dimensional code was run on these contours to examine inlet performance near the throat. Each three-dimensional job was run in a series of small steps, with each small step taking approximately 2 hours and 1 megaword of memory.

## Accomplishment Description

Solutions were obtained for the Mach 10 configuration and various off-design configurations for lower Mach numbers using the two-dimensional FNS code and grid dimensions of  $301 \times 61$ . Contours were generated for half of the three-dimensional symmetric inlet. The multiblock code was used to examine the three-dimensional flow field near the sidewall that is ultimately ingested into the inlet and remains started, thus indicating the viability of the design process developed in this study. Approximately 450 single processor hours were used in this study.

## Significance

This study has demonstrated the applicability of the two-dimensional FNS code in a parametric design setting to determine aerodynamic contours for an inlet in order to properly account for large viscous effects.

## Future Plans

Both the two- and three-dimensional FNS codes will be applied to solving other three-dimensional inlet flow fields applicable to the National Aero-Space Plane and related vehicles.

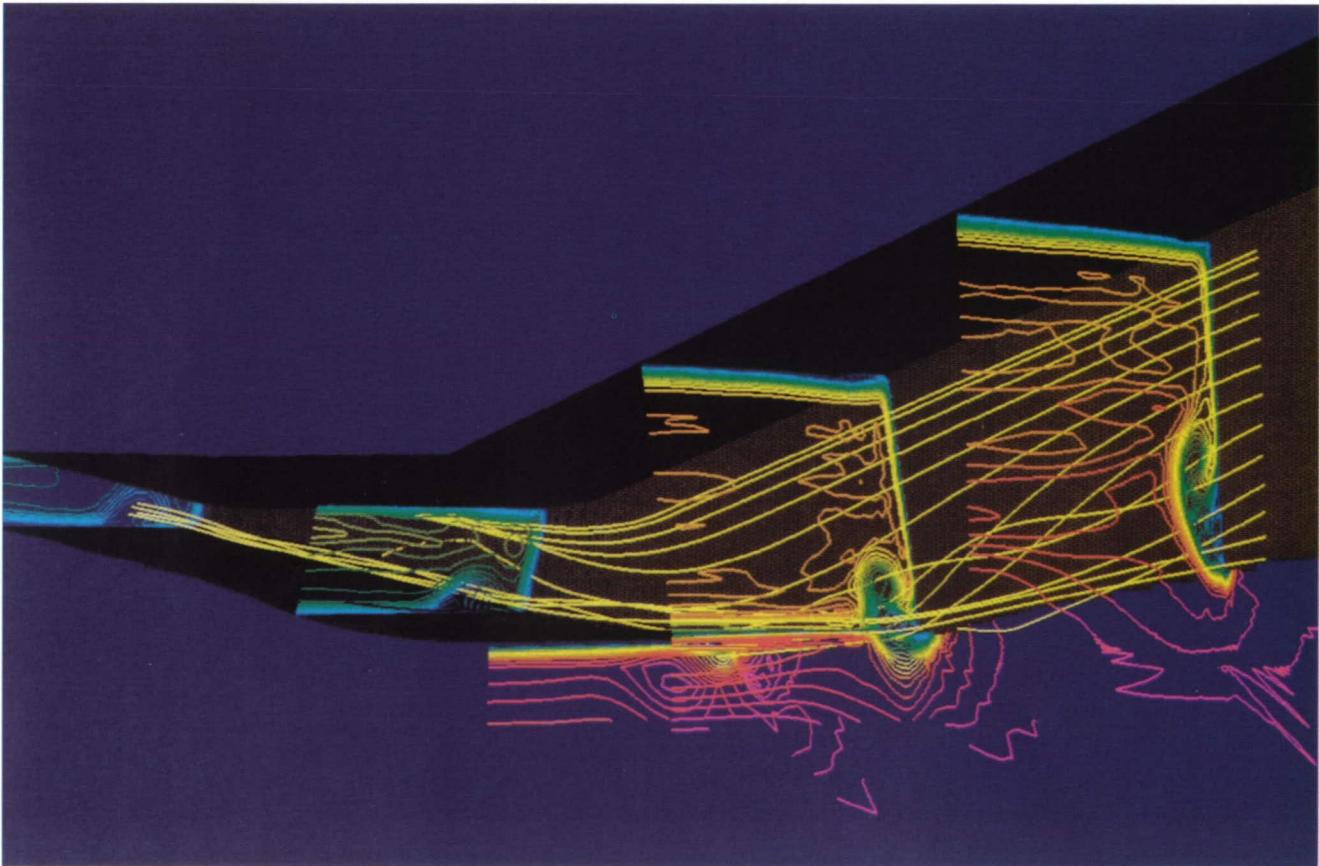

*Cross-flow Mach-number contours and particle traces from a 3DFNS solution of a representative hypersonic inlet.*

# Trapped-Vortex Flows on Highly Swept Wing Configurations

James C. Ross, Principal Investigator  
Co-Investigators: Paula Lovely and Todd Riddle  
NASA Ames Research Center

## Research Objective

To investigate the fluid mechanics involved in trapping a vortex on a wing. Generating high lift for landing and takeoff of High-Speed Civil Transport aircraft with their highly swept wings is a difficult problem. A technique that may solve this problem is to trap a vortex on the upper surface of the wing.

## Approach

The incompressible Navier–Stokes code, INS3D, was selected to compute the flow around wings tested in the NASA Ames 7- by 10-Foot Subsonic Wind Tunnel. The tests were performed at low speed so the incompressible computations were appropriate. Emphasis was placed on gaining an understanding of the flow field and mechanisms involved in trapping a vortex.

## Accomplishment Description

Computations were performed on a swept rectangular wing similar to the one tested in the wind tunnel. The computations allow a more detailed look at the flow field around the wing than was possible during the wind tunnel tests. The computed lift and drag increments due to vortex trapping were very close to the measured values. The accompanying figure shows top and end views of particle traces from the computations. The white surfaces are the vortex fences which help to generate and trap the vortex on the wing's upper surface. The character of the computed flow field is very close to that observed in the wind tunnel experiment. Closer examination of the flow showed that the vortex trapped on the wing was not as strong as expected and did not show a strong, tight core.

## Significance

These results have shown some of the limitations of vortex trapping for generating high lift on swept wings. The good match between the computed and measured lift increments give good confidence in the computations.

## Future Plans

Computations will be used to examine the trapped-vortex concept and to look for better ways to accomplish effective and efficient vortex trapping.

## Publication

Riddle, T. W. "A Numerical Analysis of Three-Dimensional Vortex Trapping." Master's thesis, California Polytechnic State University, San Luis Obispo, CA, March 1992.

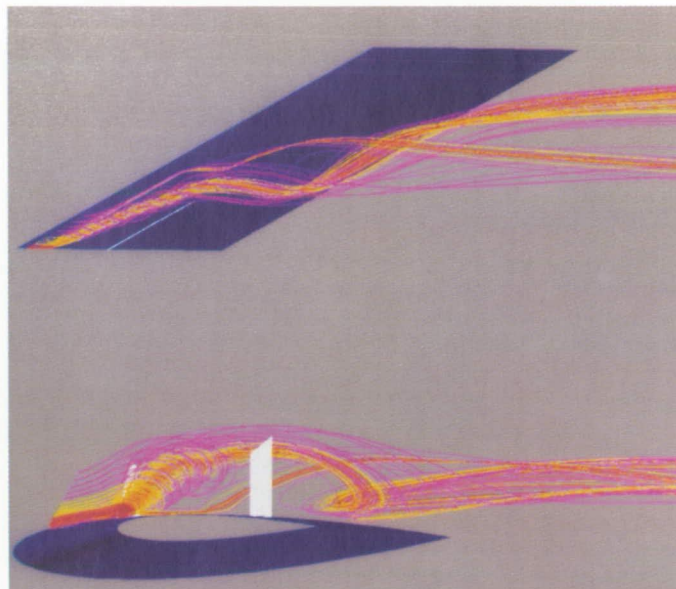

*Top and side views of vortex trapping on a NACA 0012 wing swept 60 degrees at 0 degrees angle of attack at  $Re_c = 2,000,000$ . The white surfaces are fences to generate and trap vortex.*

# Validation of a Short Takeoff and Vertical Landing Model

Karlin R. Roth, Principal Investigator

Co-Investigator: Stephen Chiu

NASA Ames Research Center/California Polytechnic State University, San Luis Obispo

## Research Objective

To evaluate the ability of computational fluid dynamics (CFD) to predict the critical flow features for an aircraft configuration that is geometrically simplified, yet retains important aerodynamic and propulsive flow physics.

## Approach

A model geometry consisting of a delta wing, tandem jets, and a blended fuselage is studied. The unsteady Reynolds-averaged Navier–Stokes equations are applied on patched or overlapped grids. Initially, an understanding of the flow physics and modeling requirements for the basic propulsive flow field is obtained, then the CFD technology is applied to the configuration.

## Accomplishment Description

Numerical requirements for the propulsive flow field were established by computing the flow of a subsonic jet exhausting into a crossflow. The Chimera grid scheme was used with  $79 \times 33 \times 66$  points in the Cartesian aerodynamic surface grid (positive half-plane) and  $50 \times 33 \times 60$  points for the embedded jet grid. Global flow features including the jet trajectory, the contra-rotating vortex pair, and the wake region downstream from the jet were simulated. The improved placement of grid points with the Chimera scheme coupled with Baldwin–Barth turbulence modeling for the flow over the surface allowed the horseshoe vortex upstream from the jet exit (a small scale feature) to be captured. Calculations using the OVERFLOW code required approximately 15 Cray Y-MP hours and 11 megawords of memory. In addition to the jet-in-cross-flow computations, the model geometry was extracted from the design data base and verified with the as-built model. Tunnel, jet, and vehicle grids were constructed and simulations have been initiated.

## Significance

Validated CFD methods will aid in the design and development of short takeoff and vertical landing aircraft.

## Future Plans

Simulation of the vehicle and jets will be completed with sonic jets at Mach 0.14 and 10 degrees angle of attack. The results will be compared with the measured flow field.

## Publications

1. Roth, K. R. "A Powered-Lift Experiment for CFD Validation." AIAA Paper 91-1731, June 1991.
2. Chiu, S. "Computational Investigation of a Three-Dimensional Navier–Stokes Model for a Subsonic Jet in Cross Flow." Master's thesis, California Polytechnic State University, San Luis Obispo, CA, May 1992.

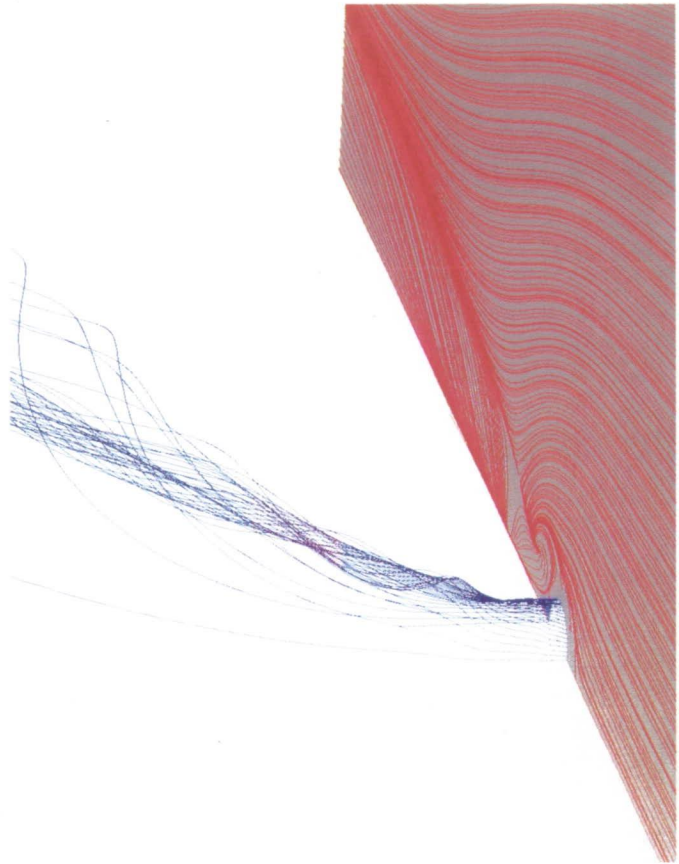

Particle traces for computation with  $M_{\text{jet}} = 0.78$  and  $M_{\infty} = 0.13$ . Red particles are restricted to the surface; blue particles are released within the jet exit.

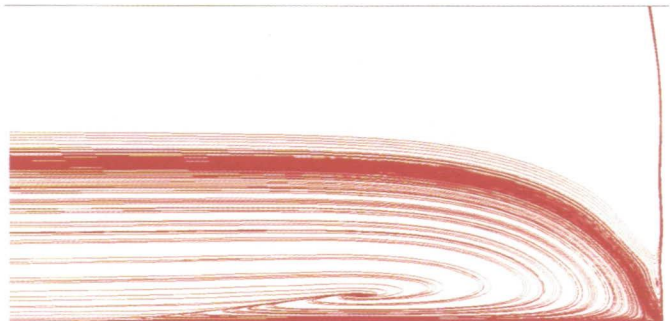

An enlarged view of particle traces in the symmetry plane upstream from the jet exit.

# Coupled Rotation–Vibration–Dissociation Processes in Hypersonic Flows

Stephen M. Ruffin, Principal Investigator  
 Co-Investigators: Surendra P. Sharma and Ellis Whiting  
 NASA Ames Research Center

## Research Objective

To determine the effect of coupled rotation–vibration–dissociation phenomena on the behavior of dissociation and recombination rates in nonequilibrium relaxation, and to model the vibrational nonequilibrium in hypersonic flows using these rates.

## Approach

The phenomena are investigated in two molecules: hydrogen ( $H_2$ ) and nitrogen ( $N_2$ ). State-to-state transition-rate coefficients for bound–bound and bound–free transitions for  $H_2$  are determined using a quasi-classical trajectory method. This requires a potential energy function input which describes the interaction of the two rotating and vibrating  $H_2$  molecules. Once rates for the transitions among all combinations of initial and final rotational, vibrational, and/or free states are obtained, the master equations are solved to yield the rotational and vibrational number densities as well as the bulk thermodynamic properties. For  $N_2$ , the transition rates are computed using the Schwartz–Slawsky–Herzberg (SSH) theory. The rotation of  $N_2$  molecules is not included in the model. To model the vibrational nonequilibrium in hypersonic flows, a quasi one-dimensional code for expanding flows is coupled with the master equations. An  $N_2$  molecule without rotation or dissociation is assumed. The transition rates at various temperatures are stored in a tabulated form and are interpolated and used as required by the fluid code. The code solves about 60 equations at each streamwise station and is computationally expensive.

## Accomplishment Description

Bound–bound and bound–free transition rates for  $H_2$  at temperatures of 10,000, 5,000, 3,000, 1,000 and 800 K have been computed. The master equations are solved for 10 cases in the 500–6,000 K temperature range assuming a constant-volume isothermal heating environment. By monitoring the average rotational energy, the rotational relaxation times are deduced and are compared with the experimental data. Good agreement with experimental data is seen. Transition rates for nonrotating  $N_2$  and carbon monoxide molecules have been computed for

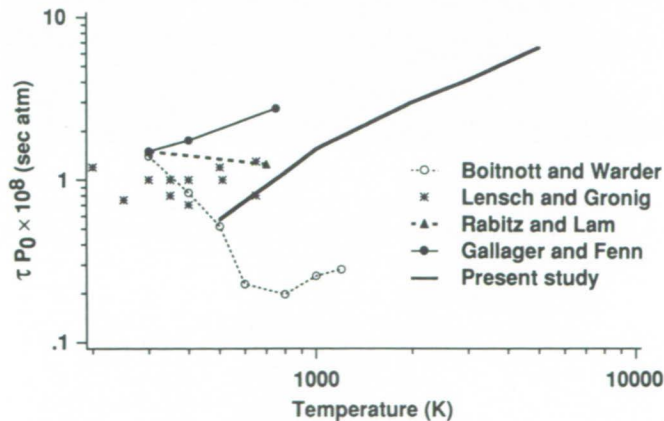

Hydrogen rotational relaxation time as a function of temperature.

vibration–translation and vibration–vibration transitions at various temperatures and have been compared with existing experimental data. Vibrational population distributions are computed in converging–diverging nozzles and in isothermal cooling simulations. The fully coupled solved simulation using SSH transition rates is able to predict the basic features of the vibrational relaxation, including population inversion; however, further study is needed for quantitative agreement.

## Significance

Detailed studies of coupled rotation–vibration–dissociation processes are vital to our understanding of high-temperature flow physics. The computational procedure for the  $H_2$  molecule will prove useful in predicting rotational nonequilibrium. A better understanding of rotational and vibrational relaxation will enable us to formulate accurate relaxation models and enhance our capability to compute nonequilibrium hypersonic flows.

## Future Plans

The  $H_2$  model will be used to study the effects of rotation in expanding flows. A better model for  $N_2$  computation rates needs to be applied. The effects of rotation and dissociation will be included in the model.

## Publications

1. Sharma, S. P. "Rotational Relaxation of Molecular  $H_2$  at Moderate Temperatures." AIAA Paper 92-2854, July 1992.
2. Ruffin, S. M. and Park, C. "Vibrational Relaxation of Anharmonic Oscillators in Expanding Flows." AIAA Paper 92-0806, Jan. 1992.

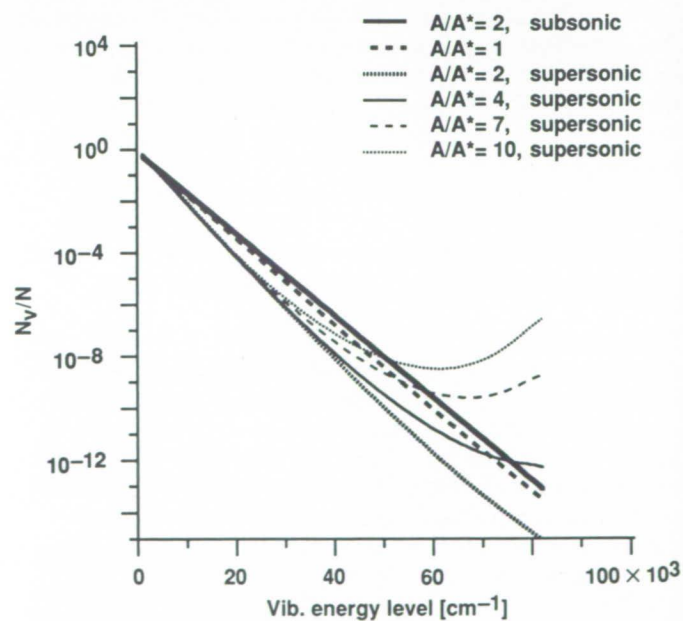

Computed carbon monoxide number densities in each vibrational quantum level in a converging–diverging nozzle.

# High-Alpha Flow Fields

Christopher L. Rumsey, Principal Investigator

Co-Investigators: James L. Thomas, Robert T. Biedron, Sherrie L. Krist, W. Kyle Anderson, Daryl L. Bonhaus,

David L. Whitaker, Thomas W. Roberts, Gary P. Warren, Beyung Kim, and Robert P. Weston

NASA Langley Research Center

## Research Objective

To perform three-dimensional Reynolds-averaged Navier–Stokes computations for aerodynamic configurations at high angles of attack.

## Approach

The algorithm CFL3D solves the compressible three-dimensional Reynolds-averaged Navier–Stokes equations. Various upwind methods are used on the convective terms, including flux–vector splitting and flux–difference splitting. Viscous terms are centrally differenced and an implicit backward time discretization is used. Either an algebraic turbulence model or a half equation turbulence model can be used to simulate turbulent flows. The code has a generalized patched-grid multiblock capability to allow the treatment of general configurations.

## Accomplishment Description

In an effort to explore the vertical-tail/vortex interaction phenomenon that occurs on F-15 and F-18 aircraft, computations are performed for a simplified geometry of a delta wing with a vertical tail surface downstream. An overlapped grid topology is employed, with the thin-layer Navier–Stokes equations solved on the delta-wing grid and the Euler equations solved on the tail grid. Preliminary computations indicate steady loads at angles of attack of 5 and 20 degrees and unsteady loads at 30 and 40 degrees. Computed vortex trajectories agree qualitatively with trajectories seen in experiments. Computations are performed about an F/A-18 wing/leading-edge-extension (LEX)/fuselage configuration and comparisons made with flight-test results. Excellent surface-pressure correlations were obtained on the forebody, but correlations degraded somewhat on the LEX surface, particularly near the wing–LEX juncture. The computed flow patterns on the forebody showed qualitative agreement with in-flight test results. Typical computations involve grids with between 300,000–2,000,000 grid points and require 1–8 Cray-2 single-processor hours per case and 8–50 megawords of memory.

## Significance

These computations aid in understanding the complex unsteady flows encountered over the F-18 at high angles of attack.

## Future Plans

Future computations of the delta-wing/tail configuration will be time accurate at the higher angles of attack to capture the correct physics of the unsteady buffet phenomenon. Development of several unstructured-grid schemes for application to the F-18 are under way, and a hybrid scheme using Navier–Stokes equations on the upstream part and Euler equations on the downstream part of the vehicle are being developed to reduce the computational requirements.

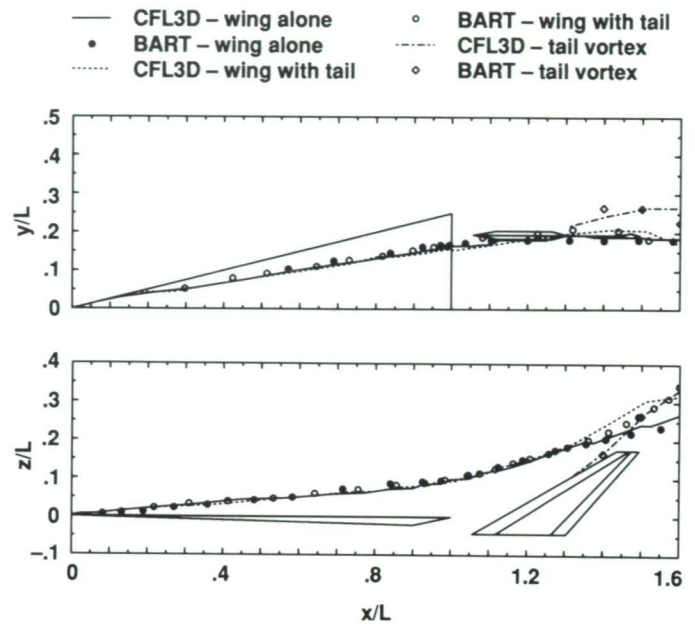

Wing-alone and wing-with-tail configurations at 20 degrees angle of attack.

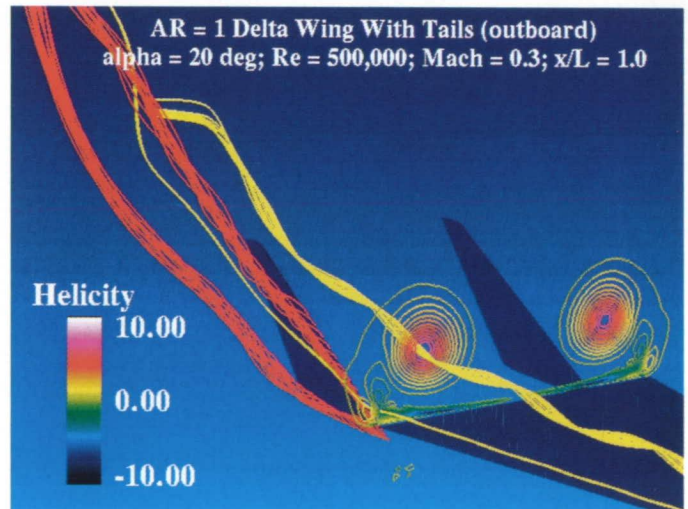

Particle traces (yellow) passing through the primary and secondary vortex cores and at the leading edge of the tail and helicity contours at the trailing edge of the wing.

# Aerodynamic Inverse Design and Analysis for a Full Engine

Jose M. Sanz, Principal Investigator  
NASA Lewis Research Center

## Research Objective

To develop an aerodynamic design methodology for multistage turbomachinery that minimizes the use of experimental data.

## Approach

The capability of the inverse design method has been demonstrated for blade sections and our goal is to extend it to fully three-dimensional multistage configurations. The method incorporates the three classic steps of aerodynamic blade design: preliminary design, blade geometry generation, and aero analysis. The procedure delivers aerodynamic blade and passage shapes and the corresponding flow solution. The inverse two-dimensional design method is an excellent tool in expanding the design data base. Turning vanes with up to 60 degrees of flow are examples of this capability. For the two-dimensional method, we solved the potential flow equations because the objective was a shock-free, nonseparating airfoil. In three dimensions the assumption of irrotationality can no longer be made and the Euler equations are the proper vehicle for three-dimensional design problems. A surface pressure distribution is the three-dimensional input driver. Extreme care must be used to determine a well posed problem. The input pressure distribution is used to drive the solution to the required design conditions.

## Accomplishment Description

Timely use of this procedure requires its implementation on a parallel machine. A 25 MFLOPS processor per passage is a reasonable hardware environment. A typical engine may require at least 32 processors. To experiment with this idea, a cluster of seven IBM RISC/6000-550 powerstations was used to run a parallel version of the code. Parallel virtual machine is used as the message passage language; processors communicate via ethernet. The results show that four RISC/6000-550 processors perform at the equivalent CPU time of one Cray Y-MP processor for a coarse-grid test case. With a medium-size grid and enhanced vectorization, the ratio of RISC/6000-550s to one Cray Y-MP processor is six, and, with a fine grid, the ratio is eight. The two Cray Y-MPs at NASA Ames and NASA Lewis were added as nodes to the cluster. The host RISC/6000-550 perfectly handles this heterogeneous cluster. The accompanying figure represents a schematic of the parallel cluster. NASA Lewis acquired 32 RISC/6000-550 processors and connected them to the existing configuration of RN/6000s and Cray Y-MPs. The cluster is performing at a sustained rate well beyond 3 GFLOPS.

## Significance

The use of parallel processing with advanced supercomputers makes possible the aero design of a full multistaged turbojet engine by direct simulation of the Euler equations.

## Future Plans

This approach should lead to an efficient method of enlarging the design data base for turbomachinery blading. Various engine configurations will be tried to fully assess the capabilities of the method.

## Publication

Sanz, J.; Pischel, K.; and Hubler, D. "The Engine Design Engine; A Clustered Computer Platform for the Aerodynamic Inverse Design and Analysis of a Full Engine." Cray Users Group, Washington, DC, Sept. 1992.

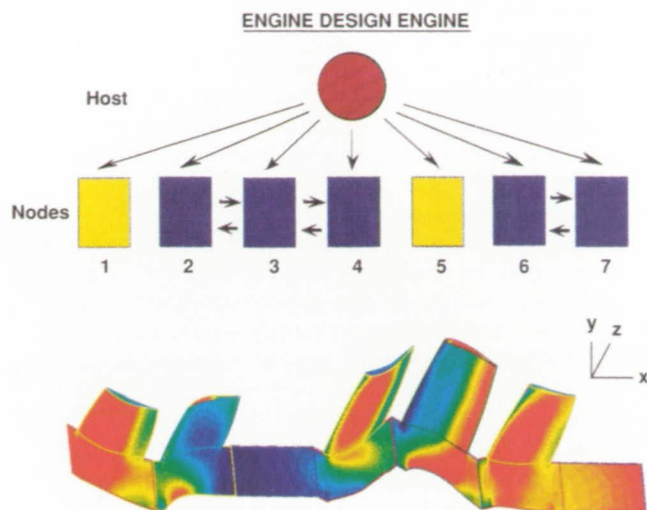

*Schematic of the parallel cluster running one compressor stage and one and a half turbine stage.*

# High Alpha Technology Program F-18 Aerodynamics

Lewis B. Schiff, Principal Investigator

Co-Investigators: Yehia Rizk, Ken Gee, and Scott Murman

NASA Ames Research Center

## Research Objective

To develop flight-validated design methodology to predict the aerodynamics and flight dynamics of aircraft maneuvering in the high-alpha regime in order to develop novel aerodynamic control concepts for increased aircraft maneuverability.

## Approach

A Reynolds-averaged Navier–Stokes code (F3D/Chimera) governing unsteady three-dimensional turbulent separated and vortical flows is used to predict the flow fields about the F-18 High Alpha Research Vehicle (HARV) at high angle of attack flight-test conditions. The code utilizes the Degani–Schiff modifications to the Baldwin–Lomax algebraic eddy-viscosity turbulence model which accounts for the vortical flow above the aircraft at large incidence.

## Accomplishment Description

The F3D code was extended to include additional geometric and flow features. The computational results for the aircraft at combined angles of attack and side slip (shown in the first figure) are in excellent agreement with HARV flight-test measurements, and computationally predict the changes in location breakdown of the wing leading-edge-extension (LEX) vortex with side slip. Time-accurate computations of the unsteady flow field downstream from the LEX vortex breakdown and the resulting unsteady loads imposed on the empennage are in reasonable agreement with wind tunnel measurements. Extensions to the code permit coupled simulations of the external and engine inlet flows. Computational results demonstrate significant effects of varying engine-mass flow rate on the LEX vortex structure. The F-18 isolated-forebody code was applied to investigate tangential slot blowing as a forebody flow-control concept for eventual flight evaluation. Computational solutions extended wind tunnel test results to full-scale flight conditions and developed a new slot configuration with a fourfold increase in slot efficiency. Recently, the slot blowing concept was evaluated in full-aircraft computations (shown in the second figure) that demonstrated the strong interaction of the displaced forebody aircraft vortices with the LEX and empennage.

## Significance

Computational results obtained in the High Alpha Technology Program demonstrate the capability to reliably predict the highly complex three-dimensional separated and vortical flows characteristic of the high-alpha regime. Slot-blowing results are an initial application of computational fluid dynamics as a design tool, rather than an analysis tool, for the high-alpha regime.

## Future Plans

The F3D code will be used for tip-to-tail computations of the F-18 configuration, with the empennage. Time-accurate computations will be used to investigate nonsteady flows and multidisciplinary computations coupling unsteady aerodynamics

with aircraft flight motions will be used to investigate performance-limiting phenomena.

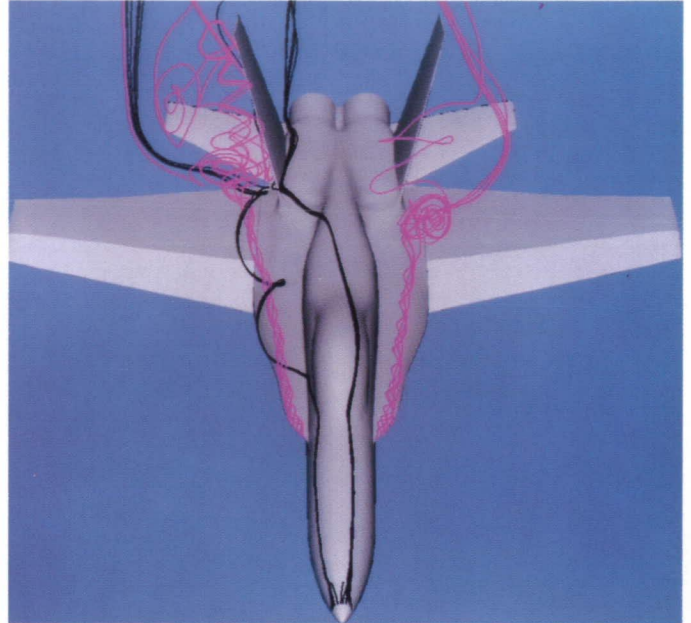

Flow field about an F-18 with side-slip forebody and leading-edge-extension vortices.

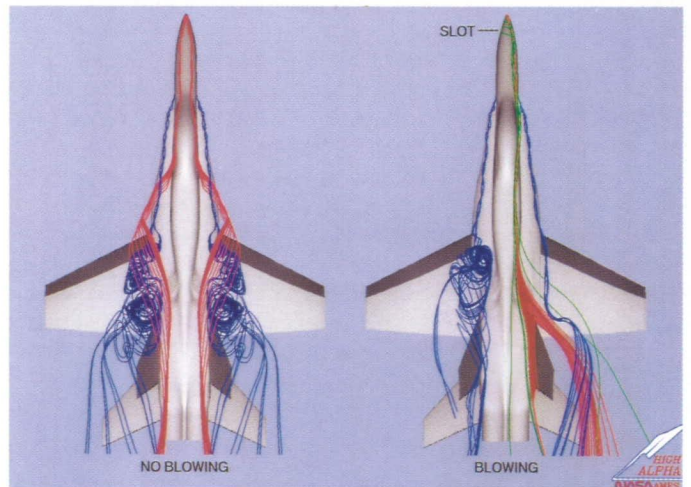

Off-surface instantaneous streamlines flow with tangential slot blowing.

# High Angle-of-Attack Vortex Flow Aerodynamics

Lewis B. Schiff, Principal Investigator

Co-Investigators: Yehia Rizk, Neal Chaderjian, David Degani, John Ekaterinaris, Yuval Levy, and Gabriel Font  
NASA Ames Research Center

## Research Objective

To develop computational techniques to treat high-incidence flows and use them to investigate the complex unsteady separated and vortical flow fields surrounding geometrically simple wings, bodies, and wing-body combinations at large angles of attack.

## Approach

Reynolds-averaged Navier–Stokes codes (F3D and NSS) governing unsteady three-dimensional laminar and turbulent separated and vortical flows are used to predict the flow fields about bodies of revolution and delta wings at large angles of attack. For turbulent-flow computations, the codes utilize the Degani–Schiff modifications to the Baldwin–Lomax algebraic eddy-viscosity turbulence model to account for the vortical flow structure which exists above the wings and bodies at large incidence.

## Accomplishment Description

The F3D code was extended to investigate the effects of an upstream disturbance in generating asymmetric vortex flows about an ogive cylinder at incidence. As shown in the first figure, we investigated the physics governing tangential slot blowing as a means of generating asymmetric vortex flows on an ogive cylinder at large angles of attack. Also, a study was done investigating the ability of the Degani–Schiff turbulence model to compute turbulent vortex flows about an ogive cylinder at large incidence. The factors affecting vortex breakdown over double delta wings was extensively studied and was extended to investigate the unsteady vortical flow surrounding double delta wings undergoing oscillations in pitch. An analogous NSS code computational investigation of unsteady vortical flow over a delta-wing/body (shown in the second figure) undergoing large-amplitude high-rate roll oscillations characteristic of wing rock was also carried out.

## Significance

The computational results yielded new insight into steady and unsteady high-alpha flow phenomena. Computational investigation of the onset of vortex asymmetry has led to better understanding of conflicting results in the experimental measurements. Computations of asymmetric turbulent separated and vortical flows over bodies at large incidence confirm the ability of this model to treat both asymmetric and symmetric separated and vortical flows.

## Future Plans

The F3D and NSS codes will be used for time-accurate computational investigations of unsteady flow response to prescribed large-amplitude high-rate vehicle motions of simple configurations. Multidisciplinary computations coupling unsteady aerodynamics with vehicle dynamic equations will be used to investigate significant flight-dynamic problems.

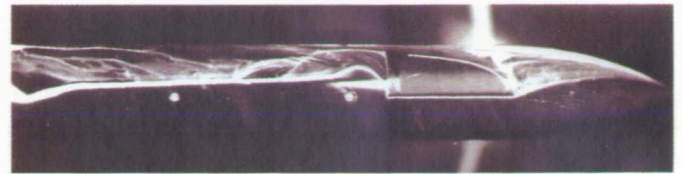

a) oil flow visualization,  $Re_D = 54000$ ,  $M_\infty = 0.06$



b) surface streamlines,  $Re_D = 52000$ ,  $M_\infty = 0.2$  (laminar)



c) surface streamlines,  $Re_D = 52000$ ,  $M_\infty = 0.2$  (turbulent)

Surface flow comparison (side view).

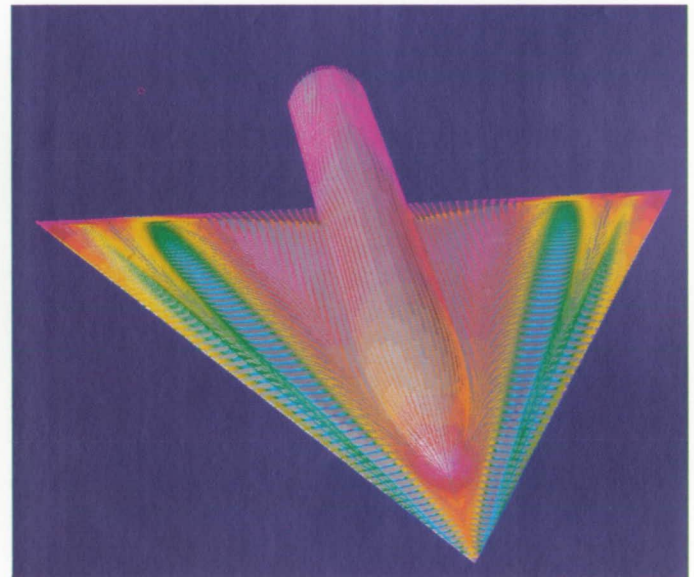

Surface flow patterns colored by pressure coefficient.

# Viscous Non-Reacting Flows in High-Speed Combustors

Balu Sekar, Principal Investigator

Co-Investigators: Douglas Davis and Daniel Risha  
WL/FIMM, Wright Patterson AFB

## Research Objective

To apply state of the art three-dimensional computer codes to predict the flow development and performance of high-speed propulsion components such as inlets, supersonic combustors, and nozzles.

## Approach

The three-dimensional time-dependent compressible Navier–Stokes equations are solved with algebraic turbulence models and with fully coupled chemistry for different reaction mechanisms to compute the mixing and diffusion phenomena that occur in a typical scramjet combustor.

## Accomplishment Description

The General Aerodynamic Simulation Program (GASP) was used to simulate the twin-jets staged injection into a Mach 2 cross flow behind a step. GASP has the capability of a general multiblock (zonal) feature that allows individual blocks of grids. Various boundary conditions and the ease of applying these for complex three-dimensional arbitrary internal/external configurations and implementation of efficient numerical algorithms make this code particularly attractive and suitable for high-speed combustor modeling. Numerical studies done for the twin-jet/ combustor configuration were used to determine key performance parameters such as penetration and mixing. The accompanying figure illustrates the computed injected air-mass fraction distribution inside the combustor at selected axial locations. Flow convergence for this configuration of two zones with  $37 \times 8 \times 44$  and  $37 \times 68 \times 63$  grids was obtained after 3,000 iterations using 16 single-processor Cray Y-MP hours and 15 megawords of memory. The computed flow compares moderately well with experiments.

## Significance

Enhanced flow-prediction methods and codes benefit the design of all air-breathing hypersonic/supersonic propulsion systems and are essential for the design and development of supersonic combustors having a high degree of mixing and overall combustion efficiency.

## Future Plans

Research is now under way to determine the relative performance, the improvements of different combustors, and the fuel injector conceptual designs applicable to scramjet propulsion. This will enhance the operating characteristics of the propulsion systems due to increased mixing and combustion and a reduction in the net flow loss.

## Publication

Sekar, B. "GASP 1.2d Results for the Transverse Air-Jet Case." Presented at the 3rd Scramjet Modeling Workshop by the CFD Group, Wright Labs/Special Projects Office, Reno, NV, Jan. 1992.

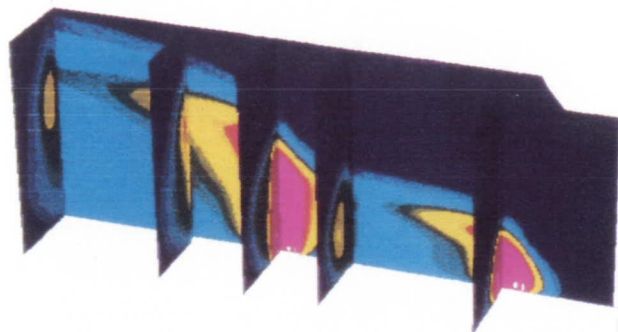

*Density at selected streamwise stations in the injected air mass fraction.*

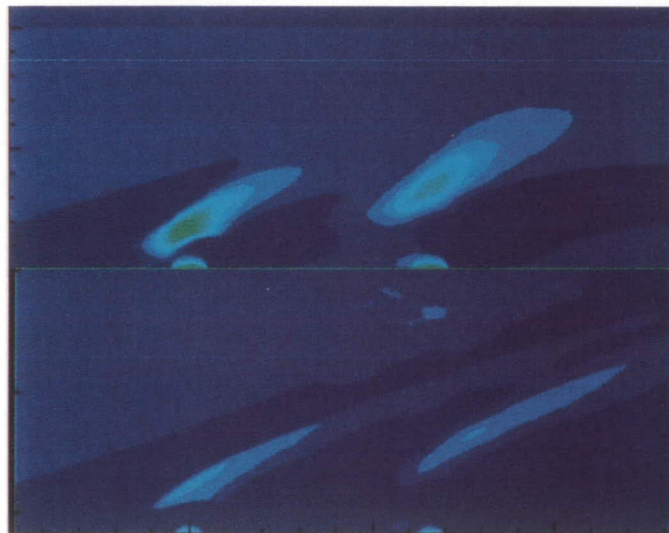

*Pressure comparison at the injector plane—P/P infinity contours.*

# Computational Fluid Dynamics Approach to Computational Electromagnetics

Vijaya Shankar, Principal Investigator

Co-Investigators: William F. Hall, Alireza Mohammadian, and Chris Rowell

Rockwell International Science Center

## Research Objective

To develop a three-dimensional electromagnetics capability to solve the time-domain Maxwell's equation employing the algorithmic rigor of computational fluid dynamics (CFD) methods. Such a capability on supercomputers is critically needed for many large-scale problems encountered in the development of low observable platforms.

## Approach

Maxwell's equations cast in conservation form are solved using a finite-volume Lax-Wendroff upwind scheme. The formulation accounts for any variations in the material properties (time, space, and frequency dependent), and can handle thin resistive sheets and glossy coatings. The time-domain approach handles both continuous wave (single frequency) and pulse (broad-band frequency) incident excitation. Arbitrarily shaped objects are modeled using a body-fitted coordinate system. For treatment of complex internal/external structures with different material layers, a multi-zone framework with the ability to handle any type of zonal boundary conditions is implemented. The time-domain electromagnetic-field values are converted to the frequency domain using fast-Fourier-transform routines, and then a Green's-function-based near-field to far-field transformation is employed to obtain the radar cross section (RCS).

## Accomplishment Description

The three-dimensional computational electromagnetics (CEM) code is highly vectorized and parallelized for Cray Y-MP and C90 architectures. On an eight CPU Cray Y-MP using the autotask mode the code runs near 2 GFLOPS, and over 10 GFLOPS on the C90 with 16 CPUs. The code is presently undergoing the validation phase while being applied to many problems of interest to low observable (LO) design. The accompanying figure shows a typical RCS calculation for a finned projectile with over 1 million grid points. For every grid point, the code needs 40 megawords of memory. The execution time required depends on the problem size and ranges from a few seconds to tens of hours. Computations of complete LO platforms at frequencies of interest will require a teraflop capability.

## Significance

CFD-based methods for solving problems in other disciplines provide the commonality and synergism required for establishing a computational environment to perform multidisciplinary computations. This CEM capability fully exploits the power of CFD algorithms that have evolved over 30 years.

## Future Plans

We will extend this CEM development to an unstructured grid cell and multiple-instruction/multiple-data architectures.

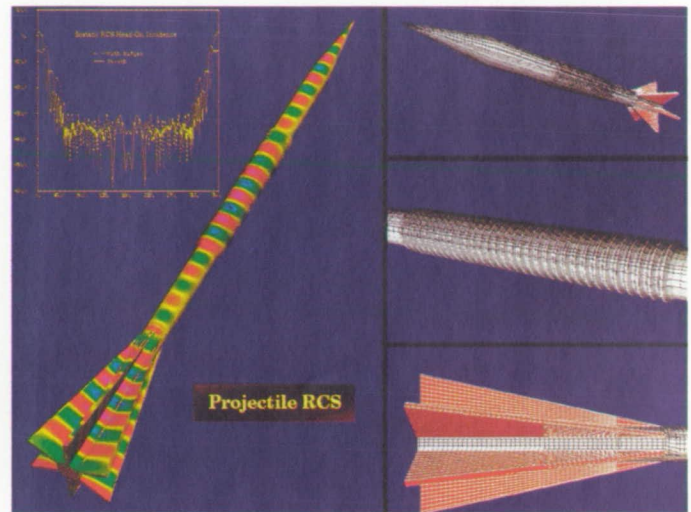

*Radar cross-section studies for a finned projectile.*

# Computational Fluid Dynamics of Store Separation

Samuel P. Shanks, Principal Investigator  
Co-Investigator: Jasim U. Ahmad  
JAI Associates, Inc.

## Research Objective

To develop a three-dimensional dynamic Chimera algorithm that solves the thin-layer Navier–Stokes equations over multiple moving bodies in order to numerically simulate the aerodynamics, missile-body dynamics, and plume of a missile separating from an aircraft. This procedure will be used to calculate powered missile separation from an aircraft and the subsequent effect of the missile on the aircraft and aircraft engine plume ingestion.

## Approach

A three-dimensional Chimera algorithm that solves the thin-layer Navier–Stokes equations over multiple-moving bodies was modified to include a total-variation-diminishing (TVD) Roe upwind method, a missile with a plume, and the subsequent propulsion forces that move the missile. Missile and plume grids were generated and imbedded in the aircraft grid.

## Accomplishment Description

To demonstrate the capability of the procedure, a missile was launched from a wing and a missile was launched from the fuselage of a F/A-18 aircraft. Several static solutions of the TVD Roe upwind Chimera scheme were run. The results of the missile launch from the fuselage of the F/A-18 aircraft are shown in the accompanying figure. Pressure contours through the axis of the missile/plume and on the fuselage surface are shown for several time slices over the first 0.4033 seconds of the missile launch from the F/A-18 aircraft. This calculation had 750,000 grid points and took 23 Cray Y-MP hours.

## Significance

The powered missile separation procedure has demonstrated a capability to analyze missile separation from aircraft and engine ingestion. With improvements and code validation, the powered missile separation procedure could be used to generate aerodynamic data bases for new missile concepts; this data base would be less expensive than data bases generated from flight-test programs. Also, the missile need not be built to generate the data base. The data base could be used in faster missile separation procedures that have a simplified aerodynamics package. As computers become faster, the procedure will replace simpler, but less accurate, missile separation procedures.

## Future Plans

Modifications will be made to the procedure to include real-gas effects, and missiles with fins will be launched from aircraft. Eventually, non-rigid aircraft and missiles will be included in the procedure.

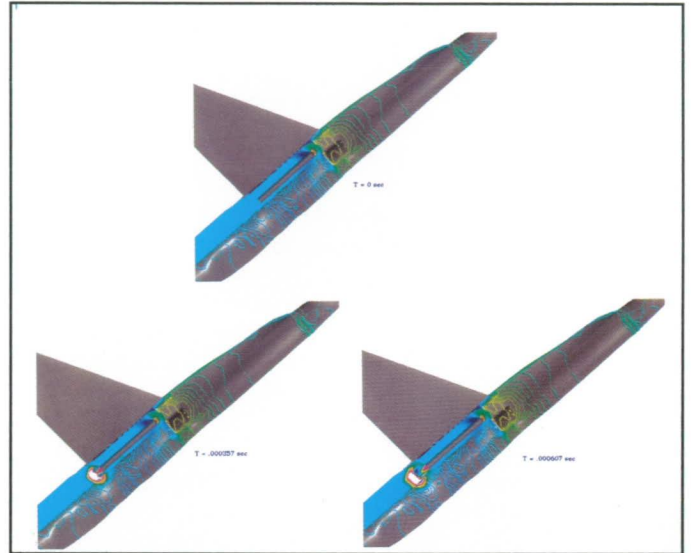

*Pressure contours through the axis of the missile plume and on an F/A-18 fuselage surface for several time slices.*

# Wankel Engine Flow Fields

Tom I-P. Shih, Principal Investigator

Co-Investigators: E. Steinhorsson, Z. Li, A. Karadag, E. A. Willis, and J. McFadden  
Carnegie Mellon University/NASA Lewis Research Center

## Research Objective

To develop numerical codes that can be used to study the flow, spray, and spray combustion in Wankel engine combustion chambers and to use the codes to study the flow physics as a function of engine design and operating parameters.

## Approach

We will develop and evaluate methods for calculating unsteady compressible flows in deforming spatial domains. Parametric studies showing the effects of engine design and operating parameters on the flow will also be performed.

## Accomplishment Description

Three codes, Lewis-2D, Lewis-3D, and LeRC3D, were developed. Lewis-2D and Lewis-3D can only calculate nonreacting flows and are based on an alternating-direction implicit finite-

difference algorithm using flux-vector splitting. LeRC3D can calculate reacting and nonreacting flows. This code uses an implicit finite-volume method that can be a lower-upper algorithm, a point-iterative process, or a line-iterative process with a variety of differencing schemes for the convection terms, including several different flux-vector splitting schemes and the advection upstream splitting method developed by Lion and Steffen.

## Significance

These codes can be used to design more efficient, less polluting Wankel rotary engines.

## Future Plans

We will improve the modeling of turbulent combustion and droplet-turbulence interactions.

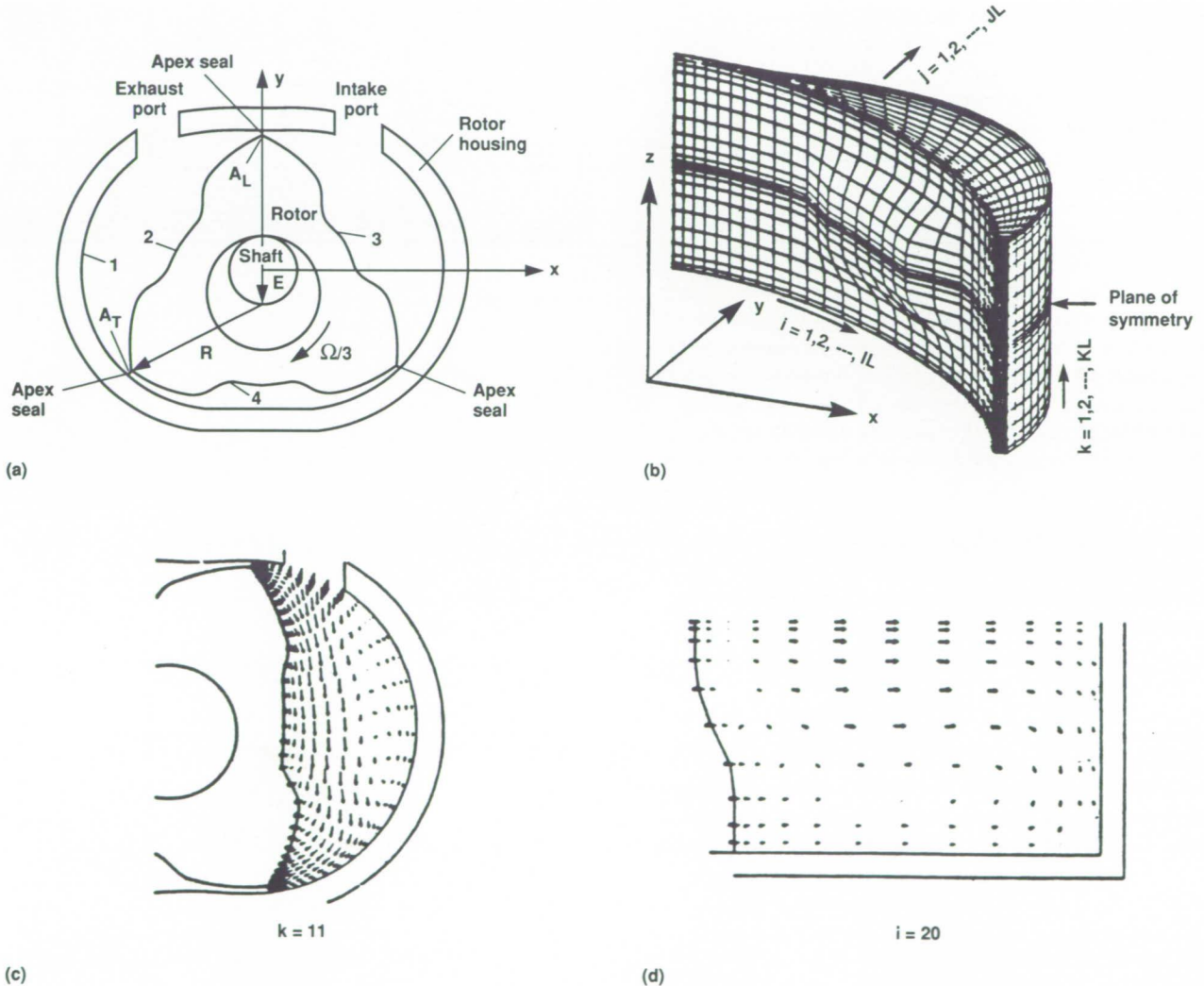

Wankel engine schematic and flow fields; (a) Wankel engine studied, (b) grid system, (c) velocity field at plane  $K = 11$ , and (d) velocity field at  $i = 20$ .

# Formation and Growth of Hairpin Vortices

B. A. Singer, Principal Investigator

Co-Investigators: R. D. Joslin and S. P. G. Dinavahi

NASA Langley Research Center

## Research Objective

To study the formation and growth of hairpin vortices in the late stages of boundary-layer transition.

## Approach

We used direct numerical simulation of boundary layers with wall-surface disturbances to create artificial hairpin vortices and analyzed data bases generated from previous numerical simulations with other types of disturbances to find similar structures.

## Accomplishment Description

Hairpin vortices were generated with a variety of wall disturbances. While the general appearance of the structures was similar, the development of the vortices was sensitive to the geometry and intensity of the wall disturbance. Very weak disturbances dissipated after the wall disturbance was removed; somewhat stronger disturbances led to the appearance of secondary and tertiary vortices. Preliminary work indicates that these stronger disturbances will form the core of a turbulent spot. The details of the process are sensitive to grid resolution, so extensive studies have been done to determine the minimum grid requirements necessary to capture the essential physics of the process. A typical grid has  $261 \times 161 \times 121$  points in the streamwise, wall-normal, and spanwise directions, respectively, resulting in computer memory requirements just under 125 megawords. At this resolution, approximately 4 Cray-2 hours are needed to advance the solution one nondimensional time unit ( $tU_0/\delta^*$ ). The accompanying figure shows the flow structure at a time of 56.54. The gray regions show the core of a hairpin vortex as marked by regions of low pressure. The primary vortex has spawned a secondary vortex high in the boundary layer and a tertiary vortex rotating with the opposite sense (as shown by the red velocity vectors) lower in the boundary layer.

## Significance

A better understanding of the importance of hairpin vortices to the late stages of transition to turbulence can yield important insights into the mechanisms responsible for turbulent production and spreading. It is anticipated that these insights will result in more realistic models for predicting flows in the transition region.

## Future Plans

The simulations will be continued until the flow becomes turbulent, allowing us to study some of the relationships between mature hairpin vortices and turbulent flow. Preliminary work to study these localized structures in a supersonic flow has begun.

## Publications

1. Singer, B. "The Formation and Growth of a Hairpin Vortex." To be published in *Transition and Turbulence*, eds. M. Y. Hussaini and R. G. Voigt. Springer-Verlag, 1992.
2. Singer, B. "Formation and Growth of Hairpin Vortices in a Boundary Layer." *Bulletin of the American Physical Society* 36, no. 10 (1991): 2644.

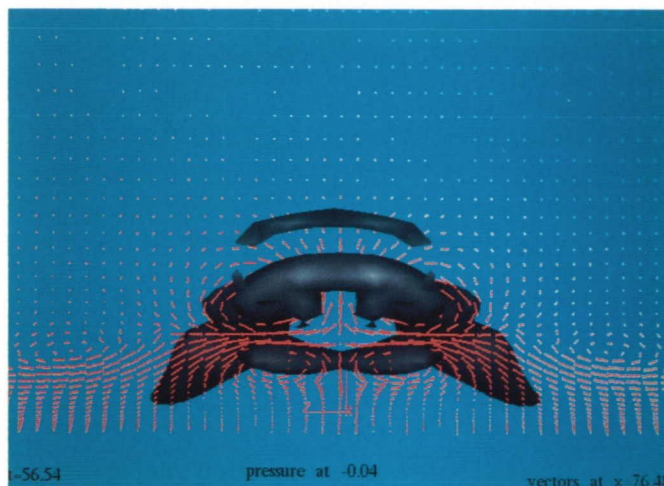

*Hairpin vortex flow structure.*

# Computational Fluid Dynamics Methods for Highly Maneuverable Aircraft

Brian R. Smith, Principal Investigator  
Co-Investigators: C. L. Reed and A. Muyschondt  
General Dynamics, Fort Worth Division

## Research Objective

To develop a Reynolds-averaged Navier–Stokes solver for the analysis of propulsion-related flow fields, and to assess the accuracy of computational fluid dynamics (CFD) solutions on these complex flows.

## Approach

A finite-volume Navier–Stokes solver with the diagonally inverted lower–upper implicit scheme of Yokota and Caughey is used. This code includes a two-equation turbulence model and wall-function boundary conditions.

## Accomplishment Description

Several complex flows were studied for this project. An advanced compression surface inlet with a turbulent-separated-shock-wave/turbulent-boundary-layer interaction was successfully simulated. A high-aspect-ratio nozzle with one vertical tail and two horizontal tails was also analyzed. The results compare well to an experimental investigation conducted in the NASA Langley 16-Foot Transonic Wind Tunnel. The experiment determined the effects of nozzle aspect ratio, empennage surfaces, and vectoring on twin engine aircraft afterbody aerodynamics. Experimental data included both surface-pressure data and balance data. The nozzle analyzed computationally had an exit aspect ratio of 5.378. The design pressure ratio of this nozzle was 5.6, which simulated a dry-power operating mode. For this test case, a Mach number of 1.2 and a nozzle pressure ratio of 5.6 were selected. The nozzle vector angle was 0 degrees and the angle of attack was 0 degrees. The tunnel conditions were Mach 1.2 and Reynolds number 4.17 million per foot. The solution was obtained by running the Navier–Stokes code, including all viscous terms, and making use of the two-equation turbulence model. The solution was executed to 4,000 iterations, at which point the residual of the mean flow equations had dropped 3 orders of magnitude and the residual of the turbulence equations had dropped 2.5 orders of magnitude from their initial values. In addition to monitoring the residuals, the nozzle-mass flow and external pressures were monitored during the last half of the run to ensure convergence.

## Significance

This project has demonstrated the accuracy of Navier–Stokes analysis for complex three-dimensional propulsion applications. This solution provides details of the flow field which are difficult to obtain experimentally, but can aid the designer.

## Future Plans

Inlet flow-field prediction is the most challenging CFD analysis problem for highly maneuverable aircraft and will be the focus of the continuing project. Predictions of flows with shock/boundary-layer interactions and strong curvature will be analyzed. Advanced turbulence models will be tested and evaluated on complex inlet flow fields.

## Publication

Reed, C. L. and Muyschondt, A. "CFD Calibration for Three-Dimensional Nozzle/Afterbody Configurations." AGARD CP-498, Fort Worth, TX, Oct. 1991.

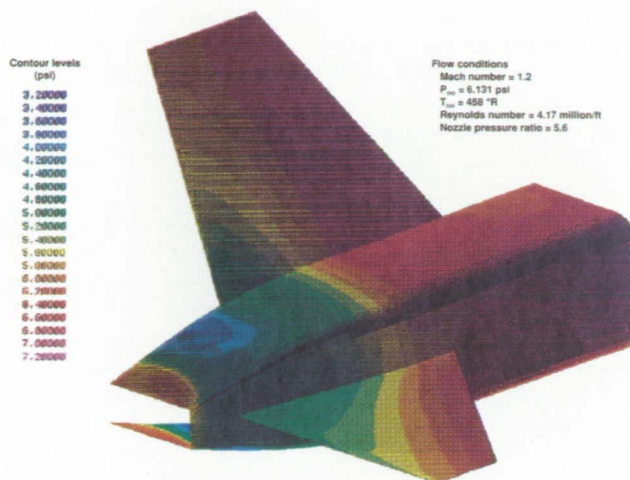

Analysis of a high-aspect-ratio nozzle with tails.

# Numerical Experiments in the Formation and Evolution of Galaxies

Bruce F. Smith, Principal Investigator  
Co-Investigator: Richard H. Miller  
NASA Ames Research Center/University of Chicago

## Research Objective

To develop and utilize numerical experiments to study the important dynamic processes at work in the formation and evolution of galaxies.

## Approach

The numerical experiments are based on the time development of a fully three-dimensional self-gravitational and self-consistent particle system. The codes can follow the motions of  $10^5$ – $10^6$  particles. The gravitational potential and forces are calculated on a  $256^3$  grid.

## Accomplishment Description

The three-dimensional particle code has been used on the Cray-2 and Cray Y-MP to study several important problems in galactic dynamics. Experiments on the nature of disk systems embedded in elliptical galaxies have resulted in fascinating new insights on the dynamic behavior of these systems. An unexpected feature is that the nucleus of the galaxy orbits around the mass centroid. These systematic motions can produce effects such as off-set centers which are often seen in observations of galaxies. Also found were long-lived global galactic oscillations which are normal modes of a stable system near equilibrium. These studies require large numbers of particles and stable experiments that extend over many crossing times.

## Significance

Observations of galaxies give us intriguing glimpses of complex, evolutionary sequences. The numerical experiments are an effective approach in understanding the dynamic sequences in galactic evolution. The computational capability is necessary to understand the wealth of new astronomical data now available. The experimental results on motions at the centers of galaxies imply that galaxies are not in a static steady state. This affects our interpretation of activity seen at the centers of galaxies, including our own.

## Future Plans

We will incorporate additional physics into the code. The gas dynamics representing the gaseous component in galaxies is currently being incorporated and will allow for galaxy formation studies and studies of galaxy interactions with highly stimulated star formation. High-resolution studies of the interplay between stellar and gas dynamics in galaxies are now possible.

## Publications

1. Miller, R. H. and Smith, B. F. "Off-Center Nuclei in Galaxies." *Astrophysical Journal* 393 (1992): 508.
2. Miller, R. H. and Smith, B. F. "Longevity of Disks in Galaxies." *Seventh Florida Workshop in Nonlinear Astronomy on Astrophysical Disks*. 1991.
3. Smith, B. F. and Miller, R. H. "Galactic Oscillations." Presented at the Third Teton Summer School, July 1992.

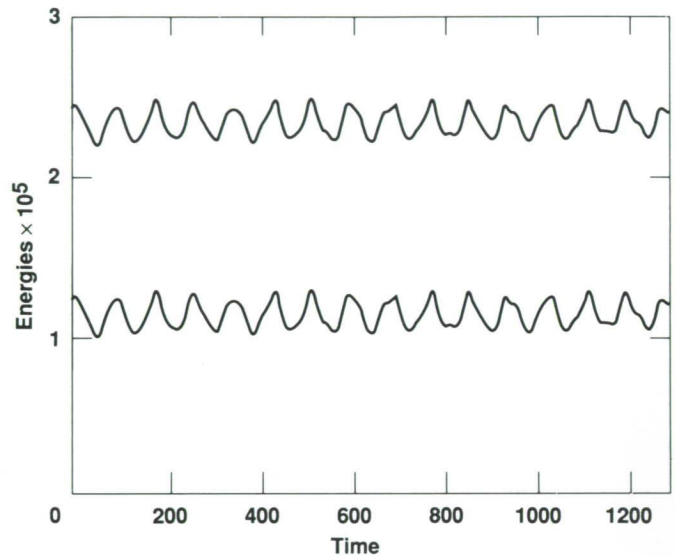

The lower track shows time dependence of the total kinetic energy from an experiment based on a spherical galaxy model. The upper track shows the total potential energy with its sign reversed. The zero is not suppressed in this plot. The kinetic energy variation is quite large and it shows no decrease in amplitude over 15 cycles of the kinetic energy oscillation. This graph represents about 50 crossing times (5 billion years for the crossing time of a typical galaxy).

# YAV-8B Aircraft Flow Simulation

Merritt H. Smith, Principal Investigator  
Co-Investigators: Kalpana Chawla and William R. Van Dalsem  
NASA Ames Research Center

## Research Objective

To validate modern computational fluid dynamics (CFD) methods for the simulation of the flow about complete vectored-thrust aircraft, and to investigate the interactions of the aircraft's major systems.

## Approach

The flow about the YAV-8B Harrier is simulated with the conditions of 30 knots forward speed and 30 feet altitude. The Navier–Stokes equations are solved on a system of 18 overset structured grids containing 2.8 million grid points and using the diagonalized Beam–Warming option in the OVERFLOW flow solver. Inlet and exhaust boundary conditions are set using a component performance model of the Harrier's Pegasus engine.

## Accomplishment Description

Comparisons to infrared images of the flight vehicle at low-level jet-borne flight conditions shows qualitative agreement regarding jet trajectories and forward penetration of the rear jets. The propulsion-induced lift loss, known as the "suck-down" effect, has also been predicted. A modification to the time-stepping procedure in OVERFLOW has resulted in a significant savings in CPU time. The majority of grid points are solved using a large constant time step to accurately convect coherent structures, while the few smallest grid cells are solved at a constant Courant

number to reduce nonlinear instabilities. The total solution time has been reduced to approximately 45 Cray Y-MP hours and 13 megawords of memory.

## Significance

The performance levels that will be demanded of future aircraft will require the careful integration of aircraft systems in order to minimize detrimental interactions like the suck-down effect. A flexible, accurate, and timely method for the prediction of these interactions will be an absolute necessity in this design environment.

## Future Plans

A  $k-\epsilon$  turbulence model, recently developed for jet flow fields, will be added. Aircraft systems, in addition to the engine and external aerodynamics, will be modeled to study a wider range of interactions. Finally, more flight conditions will be simulated to improve confidence in the capability.

## Publication

Smith, M. H.; Chawla, K.; and Van Dalsem, W. R. "Numerical Simulation of a Complete STOVL Aircraft in Ground Effect." AIAA Paper 91-3293, AIAA 9th Applied Aerodynamics Conference, Baltimore, MD, Sept. 1991.

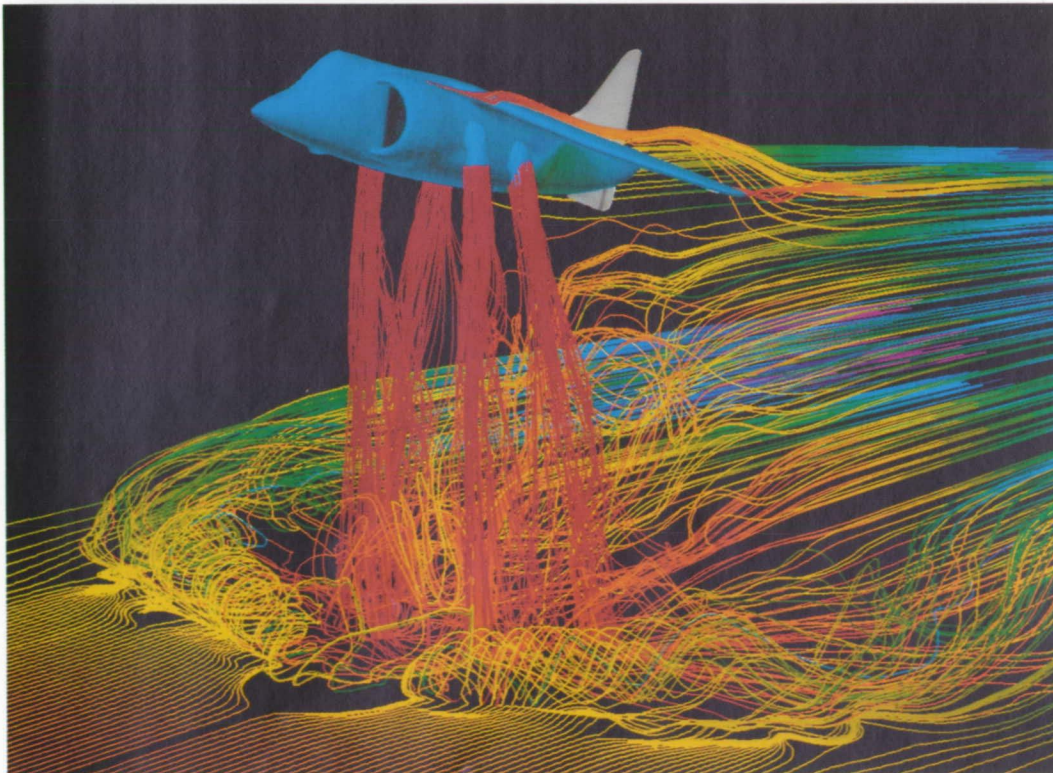

Particle traces colored by time since release for the flow about the YAV-8B Harrier at flight conditions of 30 knots and 30 feet.

# Grid Generation for Aerodynamic Configurations

Robert E. Smith, Principal Investigator  
Co-Investigator: Michael J. Bockelie  
NASA Langley Research Center/GEOLAB

## Research Objective

To develop the mathematical theory and computer software to generate structured and unstructured grids about aerodynamic configurations. A second objective is to apply existing finite-volume computer codes to compute the inviscid and viscous flow fields about these configurations.

## Approach

A series of solution-adaptive structured grids were generated for a Martian entry vehicle (MEV) design. The adaptive method uses a background grid control that retains the original grid spacing in regions of small solution gradients and employs a network data base representation of the vehicle surface to ensure the new surface grid points lie on the original surface. The thin-layer Navier–Stokes equations were solved on the adaptive grids using the TLNS3D flow solver. Unstructured grids were generated for several simple aerodynamic configurations using the VGRID3D advancing-front grid generator. Inviscid solutions were computed on the unstructured grids with the USM3D flow solver.

## Accomplishment Description

The adaptive solution method was tested by computing the steady, hypersonic, viscous flow field about the MEV at several angles of attack. A typical solution for the MEV required 300,000 grid points, 20 megawords of memory, and 1.25 Cray-2

hours. Unstructured grids and inviscid solutions were computed for several two- and three-dimensional geometries. About 30 Cray-2 hours were used for the unstructured-grid computations.

## Significance

A comparison of adaptive and nonadaptive solutions clearly showed that the adaptive solutions captured a sharper shock and more accurately predicted the stagnation point values at the nose of the vehicle.

## Future Plans

We will generate unstructured grids for aerodynamic configurations. The VGRID3D code is being modified to use surfaces defined with data base networks of bi-cubic hermite patches in order to produce smoother and more accurate surfaces.

## Publications

1. Bockelie, M. J. and Smith, R. E. "An Adaptive-Grid Method For Computing the Three-Dimensional Viscous Flow about a Re-Entry Vehicle." AIAA Paper 92-2685, 1992.
2. Bockelie, M. J. and Eiseman, P. R. "An Adaptive-Grid Method For Unsteady Flow Problems." To be published in *International Journal of Numerical Methods for Heat and Fluid Flow*, 1992.

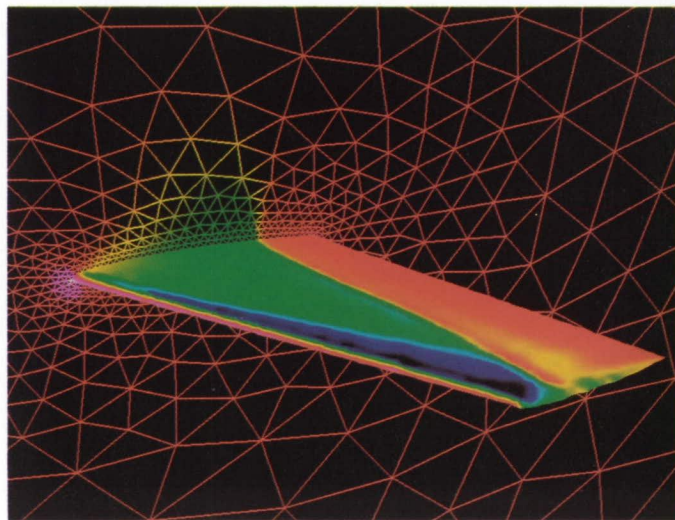
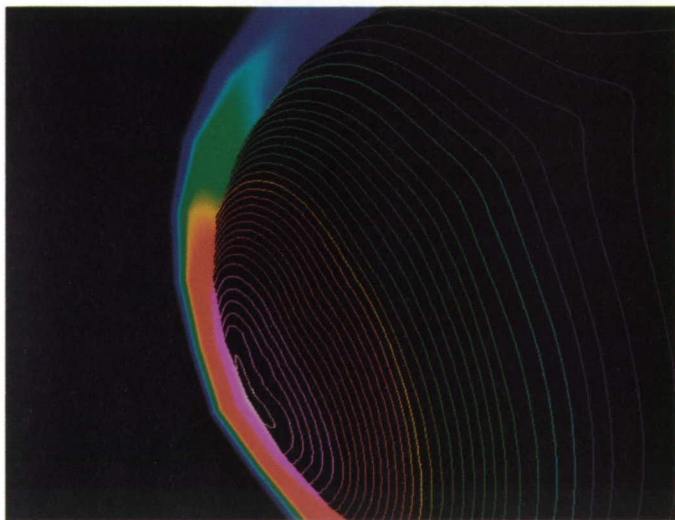

Coefficient of pressure for a Martian entry vehicle adaptive-grid solution (left) and for an M6 wing unstructured-grid solution (right).

# National Aero-Space Plane High-Speed Combustion Experiment

K. Snyder, Principal Investigator

Co-Investigators: J.-L. Cambier, D. K. Prabhu, and S. Tokarcik

NASP Joint Program Office/NASA Ames Research Center

## Research Objective

To study the start-up and choking phenomena in a hypersonic shock tunnel; to characterize the real-gas aerothermodynamic environment in the nozzle of the NASA Ames 16-Inch Hypersonic Shock Tunnel facility; to study the inlet performance of the National Aero-Space Plane (NASP) combustor to be tested in the shock tunnel; and to aid in the design of diagnostic experiments.

## Approach

Two-dimensional axisymmetric time-accurate explicit/implicit upwind total-variation-diminishing codes with multiple grid capability are used to solve the Navier-Stokes equations for chemical nonequilibrium. The computed flow fields are used in line-of-sight high-resolution spectral codes.

## Accomplishment Description

The start-up transient in the shock tunnel nozzle was computed starting with the primary shock at the end of the shock tube (driven end) and continuing until the shock reached the end of the nozzle. The temperature contours at various time intervals in the end of the driven tube and part of the facility nozzle are shown in the accompanying figure. The reflection of the primary shock off the end wall of the driven tube is clearly seen. The test section with a simple cone model was introduced and the

computation continued until the shock exited the test section. The computed real-gas environment was then used in the computation of the flow in the NASP combustor inlet. The computed cowl shock points of impact on the body surface for various cowl lengths were used in the final choice of inlet geometric parameters.

## Significance

The numerical computations provide information for detailed studies of the start-up procedure and provide good estimates of facility test times for various operating pressures. They also provide information about the real-gas environment that cannot be determined experimentally. The combustor-inlet performance study is used to determine the final size of the inlet to be tested.

## Future Plans

The axisymmetric code and a preliminary three-dimensional code were given to the University of Maryland to study the choking phenomena for realistic three-dimensional geometries. The axisymmetric code will be used in the pretest calibration of the shock tunnel for various nozzle shapes and operating pressures. The performance of the actual three-dimensional combustor inlet to be tested in the shock tunnel will be assessed.

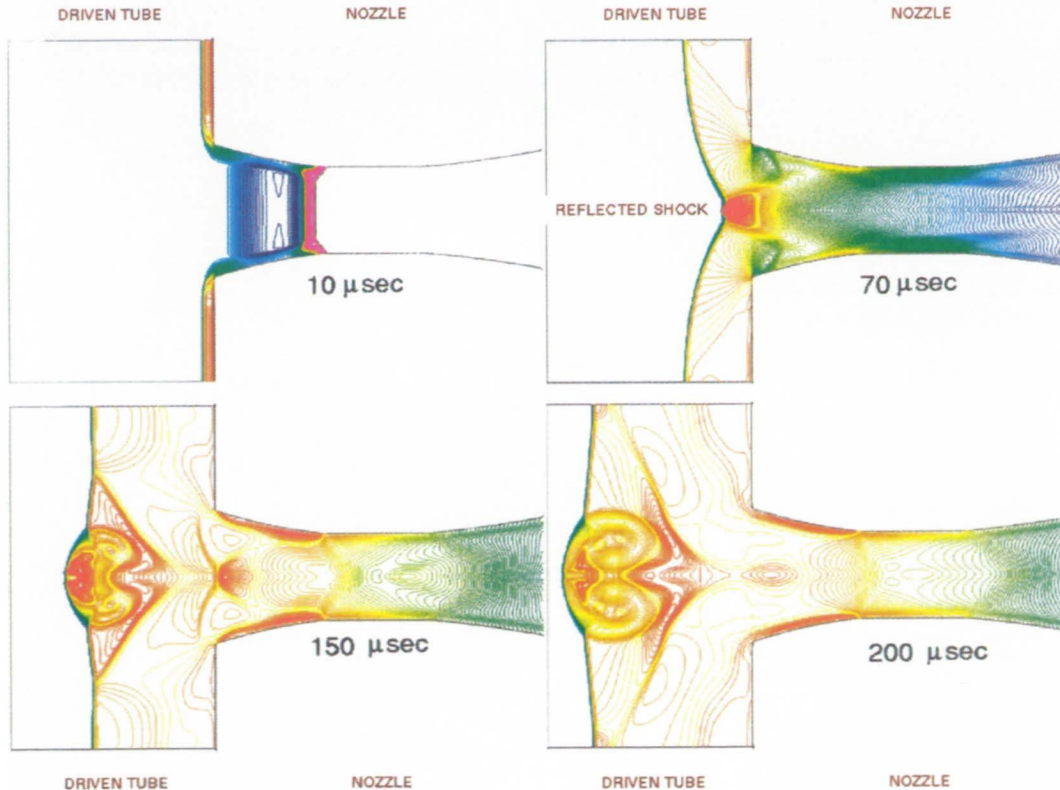

Start-up transient temperature contours in the NASA Ames 16-Inch Hypersonic Shock Tunnel. Driver pressure = 408.2 atm, enthalpy = 10.5 MJ/kg, and shock speed = 3 km/sec.

# Complex Turbulent Boundary Layers

Philippe R. Spalart, Principal Investigator  
Boeing Commercial Airplane Group

## Research Objective

To obtain highly accurate and complete flow-field information for turbulent boundary layers with pressure gradients at moderate Reynolds numbers. Theories including pressure gradient are not complete and experiments suffer from measurement uncertainties and the inaccessibility of the wall region. Simulations suffer from limited Reynolds numbers and geometry. As a result, joint studies carry considerable weight.

## Approach

Direct simulation (three-dimensional Navier–Stokes solutions with no turbulence model) will be applied using an existing spectral code with a “fringe” procedure that allows it to treat fairly general flows as long as the surface has no curvature and the fluid is incompressible.

## Accomplishment Description

The study of a two-dimensional flow that Watmuff conducted at NASA Ames is now complete. Preliminary results show that the Reynolds numbers match and that 25 million grid points are needed. Detailed comparisons reveal differences of no more than 15% for the velocity and skin friction. The more striking finding is that the velocity profile normalized by wall variables,  $U^+$  as a function of  $y^+$ , is seen to drift down in the buffer layer and log layer ( $8 < y^+ < 70$ ) when the pressure gradient is adverse. This is shown in the accompanying figure and is in close agreement with experiment. The simulation used several hundred Cray Y-MP hours, 4 megawords of memory, and 60 megawords of solid-state-device memory.

## Significance

Depending on the theory, the  $U^+$  profile in the buffer and log layers was believed to be universal, or even to drift up in an adverse pressure gradient. The present finding invalidates some of the theories and suggests caution in the use of wall functions. Combined with the experimental data, this study provides strong quantitative evidence that will be used to refine turbulence models.

## Future Plans

The triggering of instability waves in laminar boundary layers by acoustic waves and surface imperfections (receptivity) will be studied in two and three dimensions. Transition caused by large disturbances, such as suction holes, will also be considered.

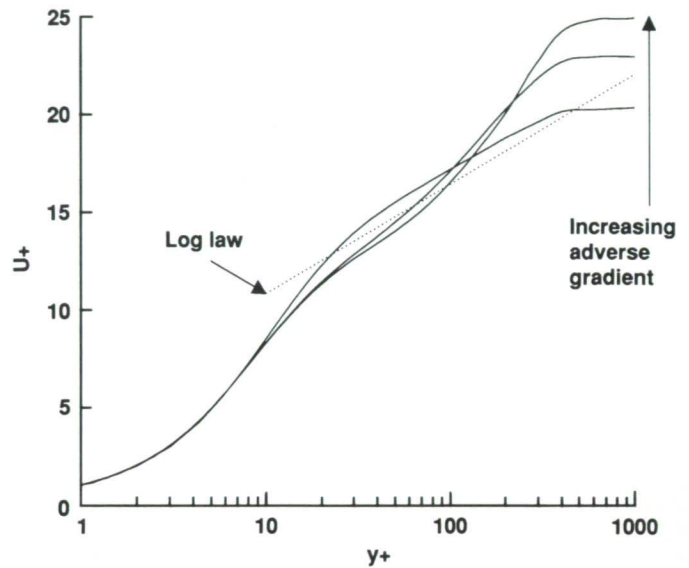

Velocity profiles in a turbulent boundary layer with pressure gradient and computed by direct numerical simulation.

# Free-Surface Effects on Boundary Layers and Wakes

Fred Stern, Principal Investigator  
University of Iowa

## Research Objective

To develop computational methods to solve the unsteady three-dimensional Navier–Stokes equations for surface-piercing bodies with free-surface gravity waves. Areas of specific interest are: detailed resolution of the solid–fluid juncture boundary layer and wake with waves; kinematics and dynamics of wave-induced separation; bow flow; and the influences of yaw.

## Approach

The computational method solves the Reynolds-averaged Navier–Stokes equations in numerically generated, body/free-surface-fitted, nonorthogonal coordinates for unsteady three-dimensional flows. A regular grid is used with finite-analytic discretization and pressure-implicit-split-operation-type velocity-pressure coupling. A two-equation turbulence model is used with either wall functions or a one-equation model for the near-wall flow (two-layer model). Various treatments for the free-surface boundary conditions and both small-domain viscous–inviscid interactive and viscous large-domain approaches are being developed. These studies are guided and supported by a concurrent program of towing-tank experiments.

## Accomplishment Description

Computational studies and comparisons with the experimental data were completed using first-order free-surface boundary conditions both for an idealized Navier–Stokes-wave/flat-plate (Sw/fp) and realistic geometries. The calculations for the Sw/fp closely agree with the foil-plate-model wake data and aid in explication of the near and intermediate wake characteristics, periodic nature of the far wake, and wave-induced separation. Interactive approach calculations for realistic geometries enabled validation of the overall approach and an evaluation of wave boundary layer and wake interaction. Recent calculations include exact treatment of the free-surface boundary conditions and detailed resolution of the solid–fluid juncture flow for the Sw/fp for laminar flow and unsteady large-domain results for realistic geometries. An average job run took 2 Cray-2 hours and 13 megawords of memory for interactive calculations, and 6 Cray-2 hours and 20 megawords of memory for large-domain calculations.

## Significance

This study stresses the fundamental importance in the fluid mechanics of nonlinear free-surface problems and the physics of the solid–fluid juncture boundary layer and wake with waves and is of strategic importance in the identification and reduction of surface wake signatures.

## Future Plans

We will continue to work on Reynolds-averaged Navier–Stokes calculations for the Sw/fp geometry using a two-layer turbulence model. Also, large-domain calculations and a large-eddy simulation for the Sw/fp geometry will be done.

## Publications

1. Stern, F.; Choi, J. E.; and Hwang, W. S. "Effects of Waves on the Wake of a Surface-Piercing Flat Plate: Experiment and Theory." Accepted by *J. Ship Research*.
2. Tahara, Y.; Stern, F.; and Rosen, B. "An Interactive Approach for Calculating Ship Boundary Layers and Wakes for Non-Zero Froude Numbers." *J. Computational Physics* 98, no. 1 (1992): 33–53.

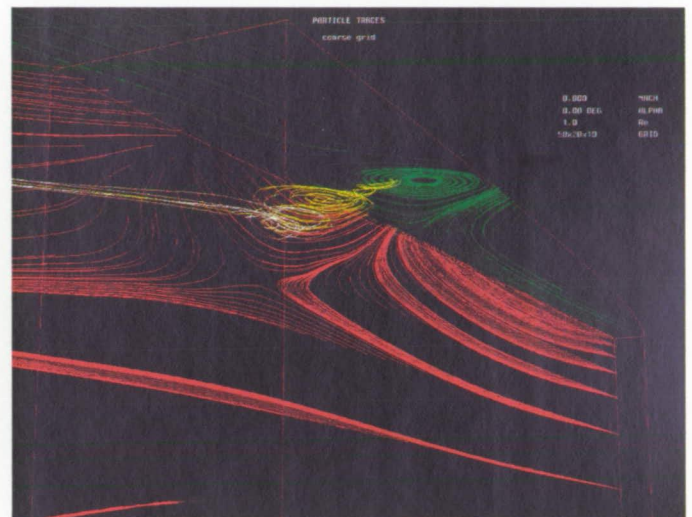

Wave-induced separation saddle on the plate and projected onto the mean free-surface flow pattern.

# Space Station Freedom Internal Flow Analysis

Eric T. Stewart, Principal Investigator

Co-Investigator: Lee A. Kania

NASA Marshall Space Flight Center/Sverdrup Technology, Inc.

## Research Objective

To facilitate the design of the air distribution system (ADS) within Space Station Freedom (SSF). By performing computational fluid dynamics (CFD) analysis of the SSF ventilation flows, we hope to assess the ability of ADS to satisfy its performance requirements and to expose any additional problems. The ADS is a subset of the environmental control and life support system (ECLSS), from which the pertinent requirements arise. An average velocity between 15–40 feet per minute must be maintained in all elements (modules and nodes) and the flow must be well mixed and circulated throughout SSF.

## Approach

First, we perform CFD analyses of each SSF element and then couple the models to simulate SSF. A CFD code developed at NASA Ames, INS3D, is used for this study along with a Prandtl–Van Driest algebraic turbulence model.

## Accomplishment Description

A CFD model of a generic module has been developed and a solution was obtained. The grid for a node was generated, and the resulting CFD model development is in progress. The model contains six inlets and six outlets. The internal flow volume is approximately 1,050 cubic feet and the grid contains 1.88 million grid points. The flow Reynolds number is 10,275 and is based on conditions at the diffuser face. The solution required 8,000 iterations to converge using 121 Cray-2 hours and 32 megawords of memory.

## Significance

Current solutions indicate that the ADS produces an average velocity of 30.2 feet per minute for the baseline case within a generic module. This easily meets the design requirements. In addition, short-circuiting does not appear to be a problem. However, visual inspection indicates that the flow does not appear to be well mixed for the baseline case and may necessitate redirection of the diffuser vanes. This flow solution enables the investigators to further examine various physical phenomena of interest to the ECLSS designers.

## Future Plans

We plan to complete the node model, then couple the node and module to form a CFD model of SSF. In addition, the computed flow fields will be used for contaminant tracking calculations. All CFD results will be validated through comparison to experimental data.

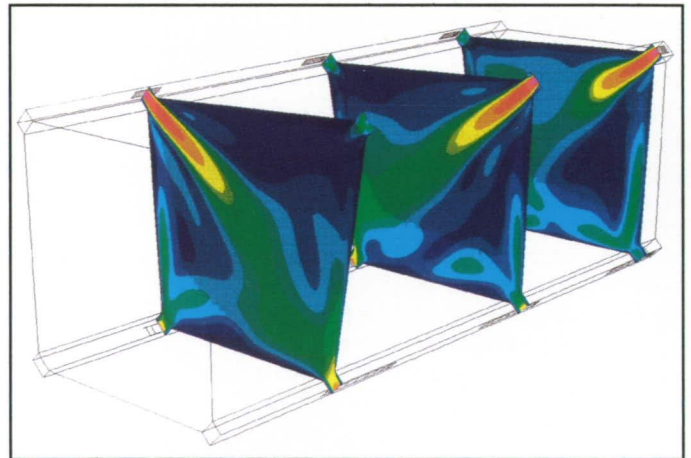
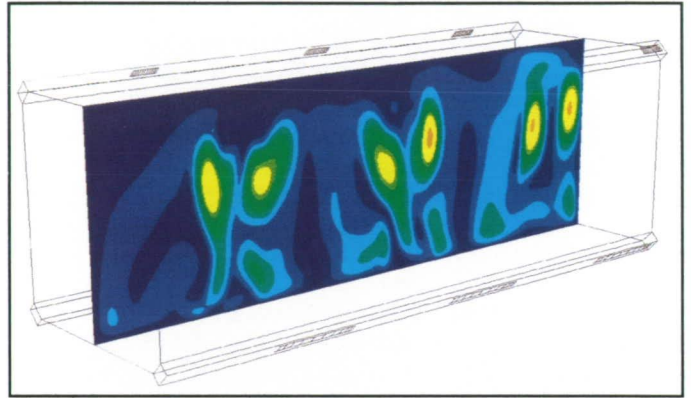

*Velocity magnitude contours for various two-dimensional planes within a Space Station Freedom module (magnitudes range from 0–440 feet per minute corresponding to colors from blue to magenta).*

# Parallel-Vector "Out-of-Core" Equation Solver

Olaf O. Storaasli, Principal Investigator  
NASA Langley Research Center

## Research Objective

To perform structural analysis on complex models requires simultaneously solving millions of equations, which requires significant memory, speed, and large and fast data transfer from peripheral storage.

## Approach

Proposed flight vehicles such as the High-Speed Civil Transport, the National Aero-Space Plane, and the Advanced Tactical Fighter require comprehensive structural analysis that can only be performed in sufficient detail on high-performance parallel supercomputers. Parallel methods to perform structural analysis on high-performance computers are required. The Cray Y-MP and gamma super-computers were explored to develop and test a method to solve large systems of equations.

## Accomplishment Description

An "out-of-core" version of the PVSOLVE equation solver was developed and tested on large-scale structural analysis applications. Two million equations were simultaneously solved in 139 seconds on one Cray Y-MP processor using the solid state disk (SSD). The algorithm was written to exploit parallelism, which further reduced the time by the number of processors used (eight on the current Cray Y-MP and 16 on the Cray C-90, where each processor is twice as fast).

## Significance

Until now, large structural analysis problems could only be attempted if they either fit in the restricted memory size of supercomputers or took extensive time using conventional structural analysis techniques. The new equation solver overcomes size restrictions by significantly reducing solution time, virtually eliminating data transfer time, which dominated previous out-of-core techniques, and eliminating large memory requirements by using the out-of-core solution in concert with the SSD.

## Future Plans

The out-of-core equation solver is being evaluated on the Cray C-90. Results will be compared with the results for the same problems solved on the Intel Delta supercomputer.

## Publications

1. Storaasli, O. et al. "A Parallel-Vector Algorithm for Rapid Structural Analysis on High-Performance Computers." NASA TM-102614, April 1990.
2. Nguyen, D. et al. "Parallel-Vector 'Out-of-Core' Analysis of Large-Scale Structures on Supercomputers." To be presented at the 2nd Symposium on Parallel Computational Methods for Large-Scale Structural Analysis and Design, Norfolk, VA, Feb. 1993.

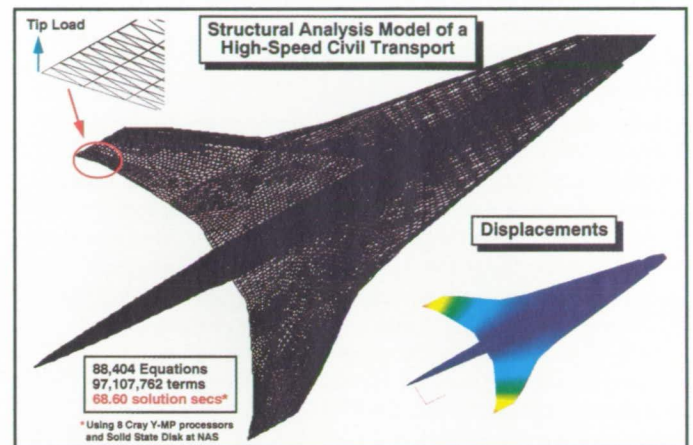

*Parallel-vector "out-of-core" solver reduces structural analysis time on supercomputers.*

# Harrier YAV-8B Wing Aerodynamics

Michael W. Stortz, Principal Investigator

Co-Investigators: Lie-Mine Gea and Gil W. Chyu

NASA Ames Research Center

## Research Objective

To define an aerodynamic modification to the wing-pylon geometry to improve the performance and combat survivability of the YAV-8B. The long-term objective is to gain a better understanding of the aerodynamic interaction between wing and pylons for future designs, demonstrate the capability of improving flow quality by using computational fluid dynamics (CFD) methodology, and to provide a design tool to optimize the aircraft's performance.

## Approach

The three-dimensional thin-layer Navier-Stokes code (F3D) with the Chimera overset grid scheme was used to calculate the transonic flow field around the Harrier YAV-8B wing with two pylons and an outrigger wheel housing. Separate grid systems are generated for the wing, each pylon (including fairing), and the outrigger wheel housing. Design iterations of the pylon and fairing combination were easily accommodated.

## Accomplishment Description

An efficient CFD procedure based on the F3D/Chimera code was developed to compute transonic flow over the wing-pylon geometry. Previous calculations had demonstrated good agreement with flight-test data and had shown that shock waves were induced by the pylon-fairing geometry. A rather large region of flow separation outboard from the pylon was identified. A new pylon-fairing shape with a concave contour and smoother curvatures near the wing-pylon junction has been proposed to improve the flow quality. The computed results show that the strength of the local shock induced by the new fairing is weakened on both sides of the pylon and the size of the separation region on the outboard side of the pylon is significantly reduced. Calculations required about 20 Cray-2 hours and 16 megawords of memory per case.

## Significance

Since pylons are required for external-store carriage, their adverse affect on aerodynamic performance should be minimized. This work demonstrates the use of CFD methodology in addressing the problem and providing solutions to current problems.

## Future Plans

The pylon fairings have been redesigned and the calculations predict significantly improved flow quality. The next step is to build and flight test the new fairings, closing the loop in the computation-to-flight philosophy.

## Publication

Gea, L.-M.; Chyu, W. J.; Stortz, M. W.; and Chow, C.-Y. "Flight Test and Numerical Simulation of Transonic Flow Around Harrier YAV-8B Wing." Presented at the AIAA 22nd Fluid Dynamics, Plasmadynamics, and Laser Conference, Honolulu, HI, June 1991.

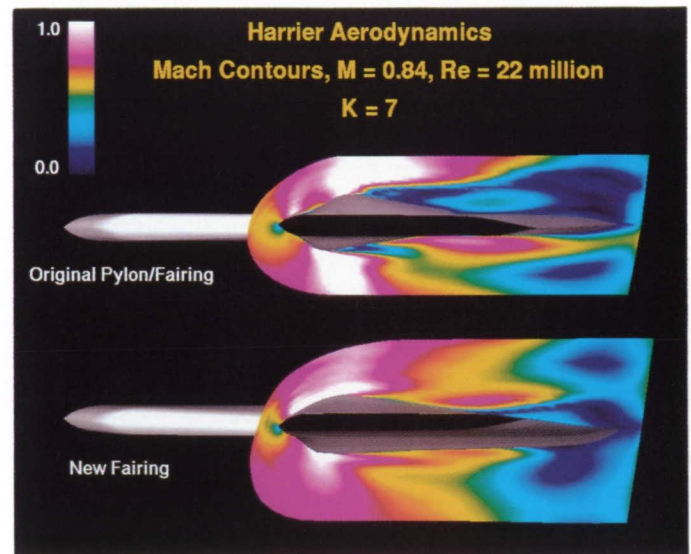

Comparison of Mach contours for pylon fairings on the outboard pylon (viewed from above; outboard at top; flow from left to right).

# Viscous Reacting-Flow Applications to Scramjet Propulsion

Sundares V. Subramanian, Principal Investigator  
Co-Investigator: Richard J. Gaeta, Jr.  
General Electric Aircraft Engines

## Research Objective

To optimize and apply state of the art three-dimensional computer codes for design and performance improvements of critical hypersonic vehicle components such as inlets, supersonic combustors, and nozzles.

## Approach

We solved the three-dimensional time-dependent compressible Navier–Stokes equations with an appropriate turbulence model and physically realistic chemical kinetics model to describe combustion phenomena occurring in the component of interest.

## Accomplishment Description

The computer program RPLUSGE was enhanced by incorporating an algebraic turbulence model, boundary conditions to accommodate cooled walls, and sets of new rate constants for hydrogen/air combustion reactions. Numerically intensive computations corresponding to Mach 18 and Mach 12 flight conditions were performed to investigate the scramjet-combustor performance characteristics. Using internally developed post-processing programs, key performance parameters such as fuel penetration, mixing, and heat release were determined for a slanted-step fuel-injection geometry through high-aspect-ratio rectangular orifices. The accompanying figure illustrates a

product of the post-processing capabilities developed. Net heat release and exothermic and endothermic heat release are shown at a distance of  $x/D^* = 25$  from the step. This combustor configuration includes a slanted step with “slit-slot” fuel injectors staggered on the the top and bottom wall. The inlet conditions simulate a flight velocity of  $Mo = 12$  while the fuel equivalence ratio is 2.4. Using  $81 \times 61 \times 41$  grid points and the nine-species 18-step finite-rate chemistry flow, convergence was obtained after 2,500 iterations that required 30 single processor Cray Y-MP hours and 22 megawords of memory.

## Significance

Enhanced flow prediction methods and codes are beneficial to all air-breathing hypersonic propulsion systems and are essential in the design and development of supersonic combustors that are characterized by a high degree of mixing, reaction, and combustion efficiency.

## Future Plans

Research is under way to determine the relative performance improvements of different combustor/fuel injector designs, with particular emphasis on quantifying important flow mechanisms that are crucial in the understanding of scramjet operation.

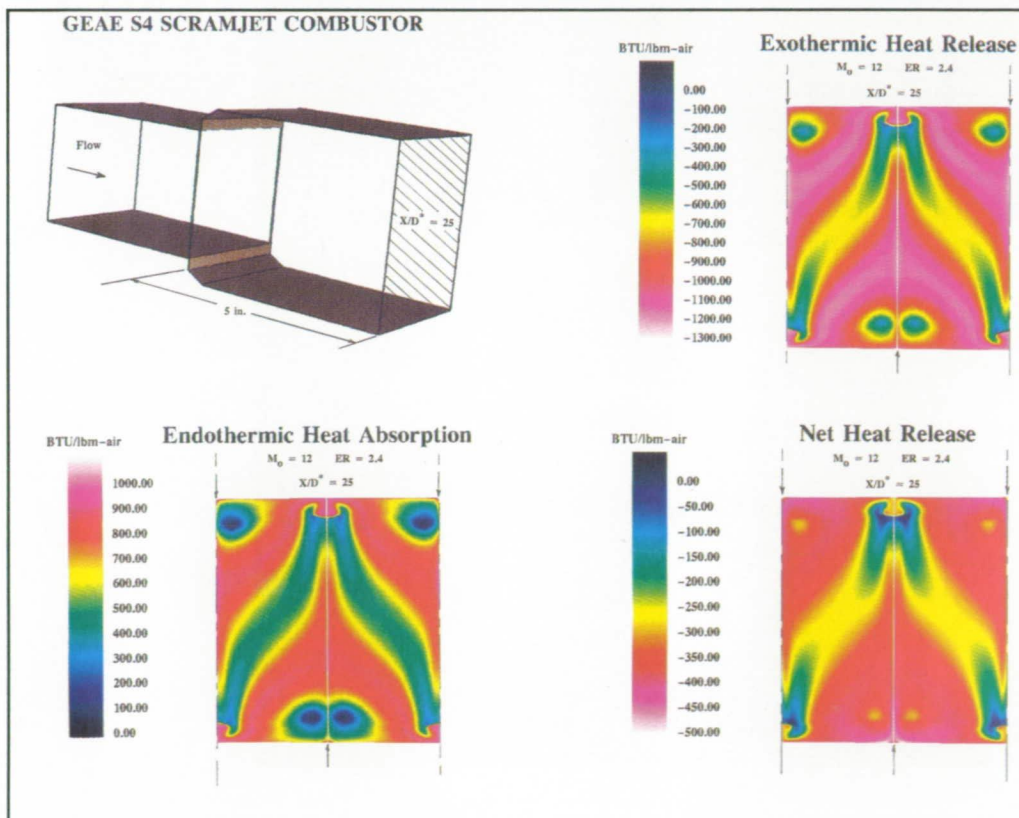

Illustration of the post-processing capabilities developed.

# Microwave Hyperthermia Computer Modeling

Dennis Sullivan, Principal Investigator  
Stanford University School of Medicine

## Research Objective

To develop better equipment and methods for deep regional microwave hyperthermia, a cancer therapy that uses microwave heat. Computer simulation is used to design new microwave applicators and to simulate treatments on existing equipment to increase their effectiveness. A method has been developed to simulate treatments of patients in an annular phased array (APA), the most commonly used device in the treatment of deep-seated cancer tumors.

## Approach

A three-dimensional frequency-dependent finite-difference time-domain method has been developed which accurately determines the electromagnetic field of microwave applicators and the body being heated for multiple frequencies. This method solves the time-dependent Maxwell's equations in difference equation form.

## Accomplishment Description

A method for planning patient treatments in the APA has been developed and put into clinical use. The APA is a heating device with four independent sources that can be energized in the

60–120 MHz frequency range. Each source can be driven with a different amplitude and phase, allowing a wide range of input parameters. Therefore, it is desirable to use computer simulation to develop the optimum treatment plan. By using a 60-slice CT scan of the patient, each treatment plan is based on a true three-dimensional, patient-specific model. The program to model the applicator and patient requires about 10 megawords of memory and 200 Cray Y-MP seconds. The main research effort, however, has switched from treatment planning on the APA to design and development of more effective applicators for deep regional hyperthermia. Methods have been developed that simulate illumination with pulses instead of single-frequency illumination.

## Significance

The computer simulation has been developed to enhance the effectiveness of hyperthermia treatments with existing equipment and to expedite the development of more effective applicators.

## Future Plans

Research continues in developing optimization methods for the APA treatment planning programs, and using current software to design more effective applicators.

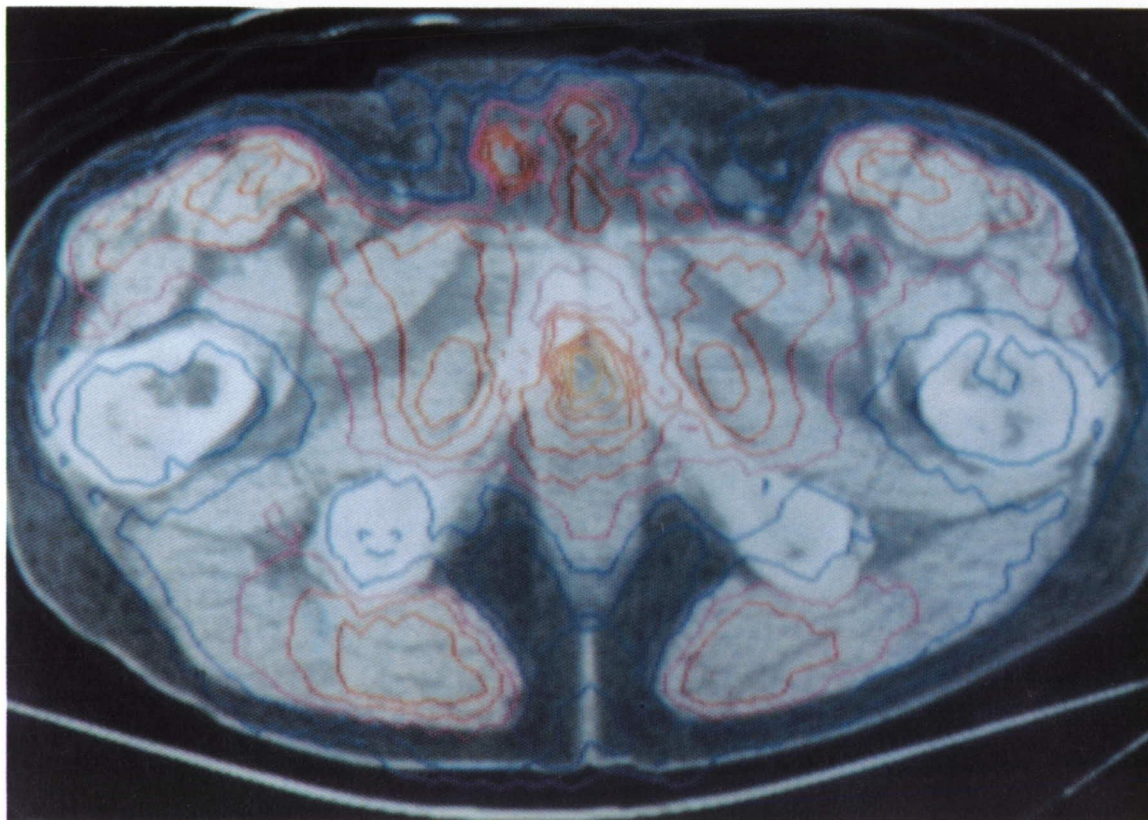

*Simulated microwave energy deposition pattern from the simulation of a patient treatment in the annular phased array. Contour lines represent 10% of normal, ranging from 10% (blue) to 90% (yellow).*

# Computational Fluid Dynamics for Naval Applications

Chao-Ho Sung, Principal Investigator

Co-Investigators: Michael J. Griffin, Chi-Wang Shu, and George T. Yeh

David Taylor Research Center

## Research Objective

To develop the capability to predict and understand the physics of the flow field about naval surface ships and submarines with special emphasis on complex vortical flows. This will aid in the innovative design of naval surface ships and submarines.

## Approach

The three-dimensional incompressible Reynolds-averaged Navier–Stokes equations, supplemented by appropriate turbulence models, are solved. Presently, a scheme based on a central-difference finite-volume spatial discretization and an explicit one-step multistage Runge–Kutta time-stepping has been developed. Convergence acceleration techniques include local time stepping, implicit residual smoothing, and multigridding.

## Accomplishment Description

The computer code IFLOW was developed for practical design applications. A run on a  $96 \times 32 \times 56$  grid requires 9.5 megawords of memory and less than 10 Cray Y-MP minutes to reduce the residuals by three to four orders of magnitude. A production run with 1.8 million grid cells requires about 89 megawords of memory and 2 Cray Y-MP hours. The quick return makes practical design iterations feasible and makes easier the task of tuning turbulence modeling. Applications to increase the

propulsor efficiency of a surface ship and reduce the noise level of a submarine have been made.

## Significance

Since vortical flows are the major source of noise and the obstacle to increased propulsor efficiency, it is crucial to develop the predictive capability of vortical flows in order to design control devices or alter configurations to reduce the production of vortical flows. Significant progress has been made in this area in the past few years.

## Future Plans

A multiblock structure allowing abrupt changes in grid spacings at interfaces will be completed and used to implement the local grid refinement and increase the ability to resolve the vortical flow. An effort will be made to validate the flow field computation about a fully appended submarine.

## Publication

Sung, C.-H.; Griffin, M. J.; Smith, W. E.; and Huang, T. T. "Computation of Viscous Ship Stern and Wake Flow." Second Osaka International Colloquium on Viscous Fluid Dynamics in Ship and Ocean Technology, Osaka, Japan, Sept. 1991.

IFLOW: Suboff Body With Sail, Alpha - 10 Deg

Streamwise Vorticity

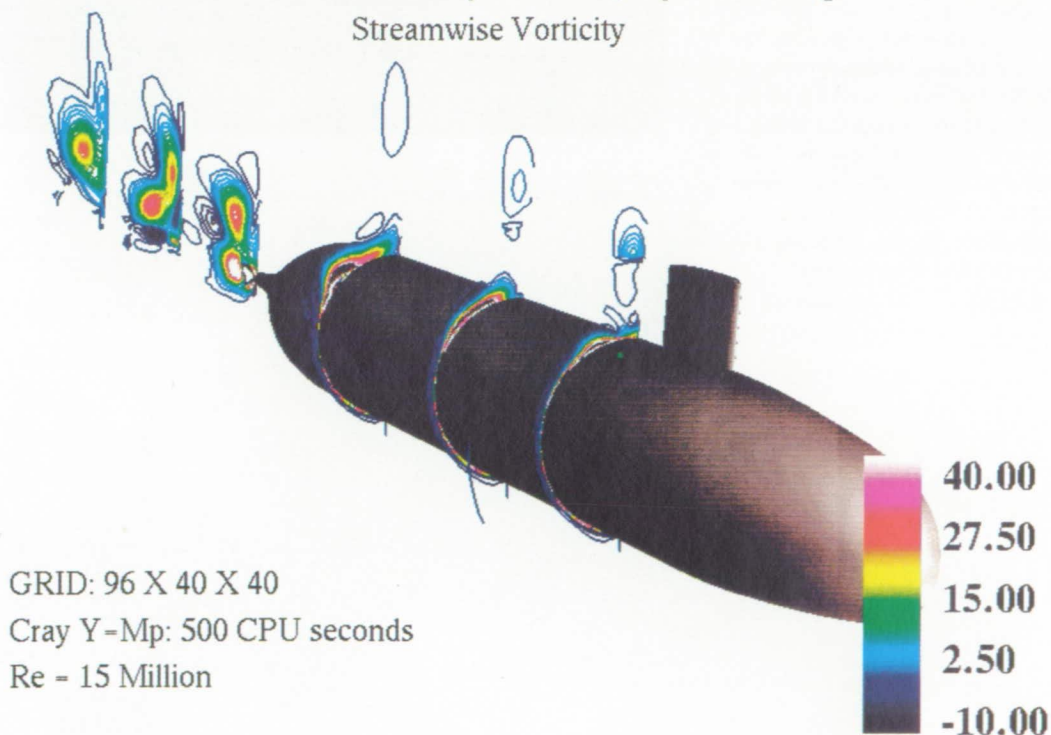

Submarine body with sail simulated using the IFLOW code.

# Simulation of Scramjet Flow Fields

R. C. Swanson, Principal Investigator  
Co-Investigator: E. Turkel  
NASA Langley Research Center

## Research Objective

To develop accurate, efficient, and reliable algorithms for solving the three-dimensional Navier–Stokes equations for high-speed internal flows.

## Approach

In this research we use a cell-centered finite-volume spatial discretization, a numerical dissipation model, and a multistage time-stepping scheme with acceleration techniques for steady-state calculations.

## Accomplishment Description

A central-difference scheme with standard multigrid techniques can be used to efficiently obtain high-speed flow solutions. In this project, several modifications to the scheme have resulted in a significant improvement in its robustness. A new initialization procedure with flow positivity constraints was implemented and is extremely beneficial in computing flows with strong shock and expansion waves since it prevents the pressure and density from becoming negative. A damped multigrid restriction operator was applied to control nonphysical upstream influence in the vicinity of a shock wave during the multigrid process. As part of the evaluation of the present multigrid algorithm for high-speed flows, we considered Mach 3 flow in a three-dimensional symmetric corner formed by the intersection of two wedges with angles of 9.48 degrees. A computation was performed for laminar flow with a Reynolds number of 3.07 million per meter, a wall temperature of 294 K, and a free-stream temperature of 105 K. This flow simulates the flow in a scramjet inlet. The associated complex flow field consists of two wedge shocks joined by an oblique shock, embedded internal shocks starting at the intersection points and terminating at the wedges, a triangular region defined by the corner shock, and two slip lines. The mesh for the calculation consisted of 32 cells in the streamwise direction and  $64 \times 64$  cells in each cross-flow plane. In the accompanying figure, the density contours for this case are displayed and the basic structure of the flow is delineated. There is reasonably good agreement between the predicted surface pressures and experimental data.

## Significance

This project has provided a capability to compute high-speed flows efficiently with a multigrid method and central spatial differencing. Such an advancement is important with the current strong interest in high-speed flight vehicles.

## Future Plans

We will demonstrate that the present three-dimensional flow solver can be used effectively for computing high-speed internal flows with chemistry.

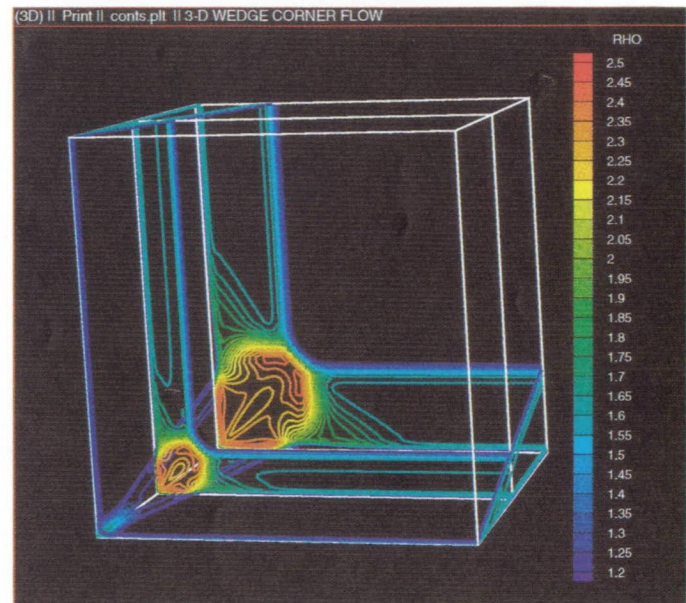

*Density contours for Mach 3 flow in a symmetric corner.*

# Low-Speed Aircraft Maneuvering Aerodynamics

Tsze C. Tai, Principal Investigator  
Naval Surface Warfare Center

## Research Objective

To investigate the deck-landing aerodynamics in an aircraft–ship interface environment and develop a capability for analyzing the effect of airwake, cross wind, wind-speed fluctuation, and gust on the lift characteristics of an aircraft during a landing maneuver.

## Approach

The three-dimensional thin-layer Reynolds stress-averaged Navier–Stokes equations are solved subject to a low-speed, nonuniform free stream due to the airwake and/or cross wind. A zonal approach is adopted where the flow field is subdivided into smaller zones. This approach allows suitable grids for different zones to be generated with only a moderate memory requirement. The NASA Ames multi-zone ARC3D/CNS code and the NASA Langley multi-zone CFL3D code will be used as the basic programs. Steady flows with nonuniform free stream due to the airwake from the ship superstructure and/or cross wind will be considered. The ship airwake will be modeled separately and its flow field will be used as input to the computation for aircraft aerodynamics.

## Accomplishment Description

A converged Navier–Stokes flow solution for a complete F-14A aircraft configuration has been obtained. The solution is based on a new grid consisting of six zones that significantly reduce the complexity of multi-zone computation. Other advantages include effectively modeling the fuselage juncture and the wing tip and easily extending to whole flow-field calculations subject to nonuniform free stream from the ship's airwake and/or cross wind. The particle trace of the flow field is shown in the accompanying figure. The effect of nonuniform free stream is evaluated by imposing an analytical defective function representing the nonuniform free stream and generating a more realistic airwake using a separate three-dimensional Navier–Stokes flow solver. The second approach, the ship airwake, is calculated by using the CFL3D code for two simple block structures on the ship. The more complex ship superstructure is then added to represent an aircraft–ship interface environment. A typical job run takes about 2–5 Cray-2 hours and 12–15 megawords of memory.

## Significance

The Navy has initiated a new research and development task to simulate analytical/computational technologies to improve the aircraft–ship interface capability. The simulation involves conditions of the ship airwake, ship motion, and interaction with aircraft or helicopters.

## Future Plans

Calculations of the aircraft–ship interface aerodynamics with real ship airwake subject to cross wind have been planned. The fixed-wing aerodynamics technology developed in this work is being extended to the Navy's V-22 Osprey rotorcraft operation.

## Publications

1. Tai, T. C. and Taylor, B. "Grid Generation about an F-14A Aircraft Configuration for Navier–Stokes Flow Calculation." Presented at the Third International Conference on Numerical Grid Generation in Computational Fluid Dynamics and Related Fields, Barcelona, Spain, June 1991.
2. Tai, T. C. and Walker, M. "On Three-Dimensional Flow Separation Criteria." AIAA Paper 91-1740, presented at AIAA 22nd Fluid and Plasma Dynamics and Lasers Conference, Honolulu, HI, June 1991.
3. Tai, T. C. "Flow Separation Patterns Over an F-14A Aircraft Wing." *Journal of Aircraft* 28, no. 12 (Dec. 1991): 818–827.

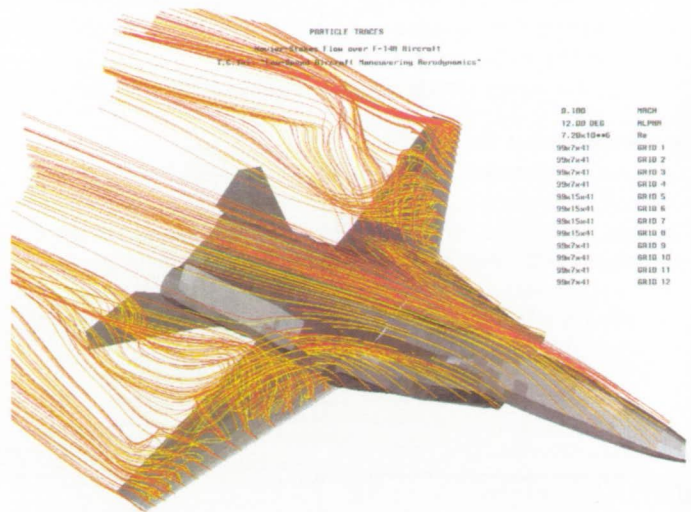

Navier–Stokes flow over an F-14A aircraft.

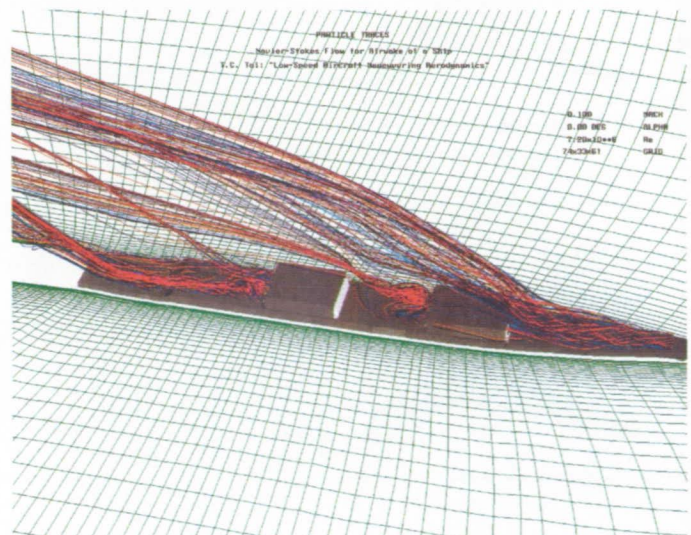

Navier–Stokes flow for the airwake of a ship.

# Unstructured Multigrid Euler Solver

Rajiv Thareja, Principal Investigator

Co-Investigators: J. Peraire, J. Peiro, and K. Morgan

Lockheed Engineering and Sciences Company/Imperial College/University College, Wales

## Research Objective

To develop a low-storage, computationally efficient algorithm for the solution of the compressible Euler equations on unstructured tetrahedral meshes.

## Approach

An unstructured-mesh generator is used to create a sequence of refined meshes about complex aircraft shapes. Steady-state flow conditions are computed by advancing the transient form of the Euler equations using a multistage time-stepping scheme. A side-based data structure is employed for the three-dimensional mesh, which reduces the memory demands. For a sequence of successively coarser nested meshes, multigrid solution algorithms accelerate convergence. The meshes are unstructured and not nested, thus the nodes on one grid do not coincide with the nodes on the next coarser or the next finer grid. The multigrid concept has been extended to these meshes.

## Accomplishment Description

The multigrid scheme has been developed, tested, and applied to several complex realistic aircraft shapes. Appropriate intergrid transfer procedures between such unrelated meshes have been developed and different cycling strategies between meshes have been implemented. A higher-order form of the diffusion operator has also been incorporated. The computational performance of

the flow solver is dramatically improved in terms of lower memory requirements and improved rates of convergence via the multigrid scheme. The accompanying figures show three progressively refined surface meshes for Mach 0.85 flow at 2 degrees angle of attack over a twin-engine Dassault Falcon. The finest mesh has 863,967 elements and 161,608 nodes. A three-stage time-stepping scheme and a double-W cycle was employed with one pre- and one post-smoothing step on each mesh. The computed steady-state pressure contours on an aircraft surface are shown in the last figure. Computations took about 3 Cray Y-MP hours. The multigrid code requires 89 storage locations per node, which compares quite favorably to 63 per node for the flow solver with a single grid.

## Significance

The scheme was used to solve flows about realistic complex aircraft bodies in the transonic-flow regime. A converged solution is obtained on large meshes in 2–3 Cray Y-MP hours.

## Future Plans

We will extend the scheme to solve the Navier–Stokes equations, including the automatic generation of semi-structured meshes.

	Elements	Nodes
Mesh 1	100215	19048
Mesh 2	212433	40322
Mesh 3	863967	161608

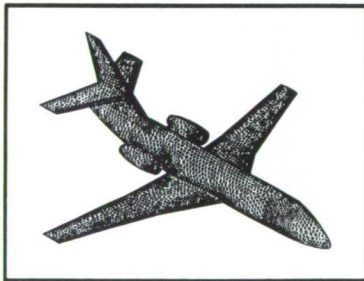

(a) Mesh 1

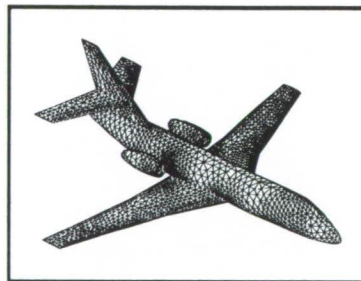

(c) Mesh 3



(b) Mesh 2

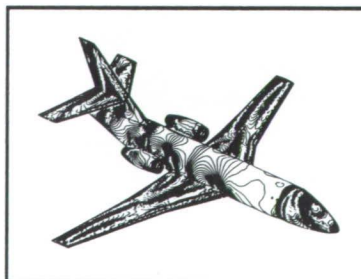

(d) Pressure contours

(a)–(c) Three progressively refined surface meshes. (d) Computed steady-state pressure contours on an aircraft surface.

# Multi-Dimensional Simulations of Noctilucent Cloud Formation

Gary E. Thomas, Principal Investigator  
Co-Investigator: Eric J. Jensen  
University of Colorado, Boulder/NASA Ames Research Center

## Research Objective

Perform two-dimensional numerical simulations of noctilucent clouds (NLC) as they are affected by atmospheric gravity and tidal-wave perturbations.

## Approach

The NASA Ames aerosol model is applied to the microphysical evolution of ice and dust particles in the mesosphere and a comprehensive set of physical and dynamical processes believed to be important for cloud evolution is included. Physical and optical properties are simulated for comparison to ground-based and satellite NLC data.

## Accomplishment Description

The aerosol model was modified to accommodate the particular environment and specific properties of NLC particles. The first set of wave perturbation calculations designed to assess the gross properties of the wave-cloud effects is nearly finished. A typical job run requires 0.5 Cray-2 hours and 8 megawords of memory.

## Significance

The first two-dimensional simulations of NLC were performed. It is a long-standing problem to explain the highly structured appearance of NLC in terms of wave action. It is unknown if the waves merely perturb the altitude of the cloud layer due to uplift and downlift in the wave crests and troughs. The adiabatic temperature changes and the divergence/convergence of winds may affect the microphysics, and therefore the physical and optical properties of the cloud particles. We have shown that the time-scale ratio of the wave compared with the time scale of ice formation may answer these unknowns. When this ratio is less than unity, the wave modification is primarily dynamic in nature; when it is somewhat greater than unity, microphysical processes become significant. Waves have a significant effect on eroding the overall cloud brightness. NLC are unstable in time periods greater than one day unless the air temperature is lower than expected from simple saturation requirements.

## Future Plans

Wave erosion effects will be characterized in terms of a decay time. This will be useful in modeling studies of the cloud occurrence and brightness. The effects of the mean circulation on the occurrence of NLC and on its variation with latitude will be studied. The two-dimensional simulation will be applied to a more realistic situation of tidal/gravity-wave interactions using the mechanistic model of D. Fritts from the University of Colorado.

## Publication

Jensen, E. "Numerical Simulations of Wave Patterns in Noctilucent Clouds." Symposium on Noctilucent and Mesospheric Clouds, Middle Atmosphere Science Symposium, International Union of Geodesy and Geophysics Meeting, Vienna, Austria, Aug. 1991.

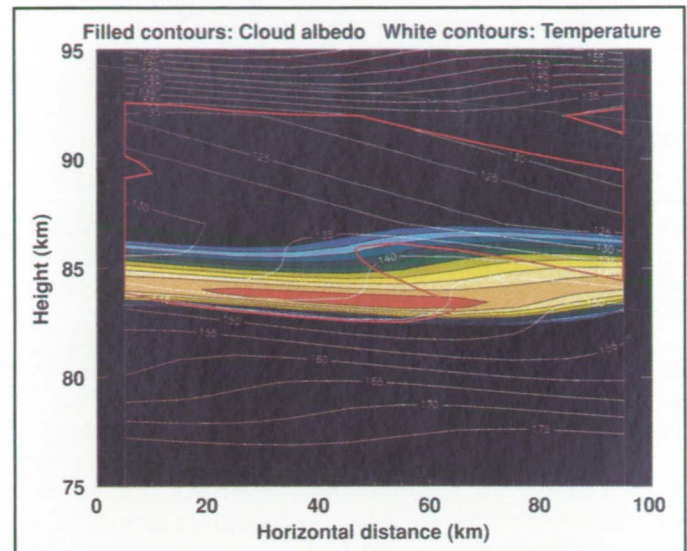

*Numerical simulation of wave-disturbed noctilucent cloud brightness; wavelength = 100 km, period = 1 hour. Brightness (albedo) shown in color; red = high, blue = low. Temperature contours (white lines) are in K.*

# Stratospheric Ozone Destruction

Owen B. Toon, Principal Investigator  
NASA Ames Research Center

## Research Objective

To develop the capability to predict the particles in the stratosphere so that heterogeneous chemical reactions involving these particles can be investigated.

## Approach

A microphysical cloud model, which treats heterogeneous nucleation, condensation of water and nitric acid vapors, evaporation, coagulation, and particle transport, has been used to simulate cloud properties, and a module to treat homogeneous nucleation has been developed. The model has been applied to investigate new particle formation in the polar regions and in the El Chichon and Pinatubo volcanic clouds.

## Accomplishment Description

Observations show that new sulfate particles are forming in the polar winter stratosphere at altitudes above about 25 km. The origin of these particles is unknown and some researchers have implied that novel chemistry may be occurring. We have numerically investigated this process and found that the low temperatures in this region of the stratosphere lead to the nucleation of any sulfuric acid vapor that may be present. We are investigating whether the sulfuric acid vapor is the result of photochemical formation of new sulfuric Pinatubo volcanic clouds. Our goal is to understand how these particles evolve in space and time and the degree to which they may provide surfaces for heterogeneous reactions.

## Significance

Ozone destruction has been observed at both poles and in the midlatitude stratosphere. It is clear that these losses of ozone are triggered by reactions that occur on the surfaces of particles in the stratosphere. In order to predict future ozone losses, we must have a predictive capability for stratospheric particles and we also need to determine the impact that supersonic aircraft might have on these particles. Aircraft contribute particles by injecting exhaust particles, by adding sulfate to the stratosphere, and by increasing the abundance of nitrogen oxides and water vapor. Successful simulations of stratospheric particles and comparisons with observations will contribute to the development of this predictive capability.

## Future Plans

The work on stratospheric ozone has been stopped. Work under this task has been redirected to tropospheric chemistry and a limited number of ozone simulations are now being done.

## Publications

1. Toon, O. B. and Turco, R. P. "Polar Stratospheric Clouds and Ozone Depletion." *Scientific American* 264 (1991): 68-75.
2. Hamill, P. and Toon, O. B. "The Physics of Polar Stratospheric Clouds." *Physics Today* 14 (1991): 34-42.

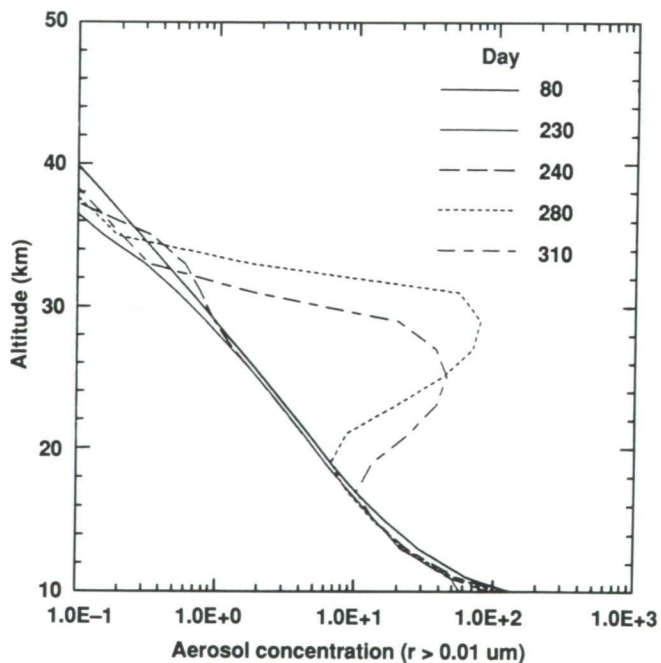

The concentration of aerosols in the polar stratosphere is computed as a function of time and altitude. Micrometeorites are present at high altitude and serve as nuclei for sulfuric acid condensation. Homogeneous nucleation occurs and the result is the formation of a new layer of particles at an altitude between 20-30 km, just in and above the ozone hole.

# Radar Cross-Section Studies

Ban H. Tran, Principal Investigator  
Rockwell International, North American Aircraft Division

## Research Objective

To develop and verify a range of the most accurate and efficient radar signature prediction and optimization tools in advanced aircraft design.

## Approach

Three codes were used to evaluate and optimize the electromagnetic scattering from structured airfoils, inlets, and flat plates coated and partially coated with layers of radar absorbing materials. They were the adaptive integral method code (AIM), the electromagnetic surface patch code (ESP), and the body of revolution methods of moments code (BoR).

## Accomplishment Description

A study of a two-dimensional leading-edge configuration was conducted using the AIM code. An extensive study of long cylinders, cone cylinders, and missile-type configurations, both perfectly conducting and coated, was performed using the BoR code. The BoR-code study assessed the importance of and the means of controlling surface wave diffraction. A thorough study of flat-plate configurations was conducted and radar signatures of perfectly conducting plates, coated plates, and plates terminated with resistive sheets were computed using the AIM and ESP codes. When available, comparisons with measured data were made. Particular attention was focused on achieving high accuracy in the most difficult numerical case of scattering at grazing incidence.

## Significance

The numerical study of radar cross-section performance of various test bodies will have significant impact on the cost and duration of current and future aircraft design cycles.

## Future Plans

A significant improvement of the aircraft design cycle can be achieved by the development and implementation of radar-signature optimization techniques. The radar-signature prediction codes will be interfaced with an optimizer, and multi-parameter optimization runs yielding configurations with the most desirable material properties will be performed.

## Publication

Tran, H. B. "Modern Radar Cross-Section Computation Techniques." *IEEE AP-S International Symposium*. Chicago, IL, 1992.

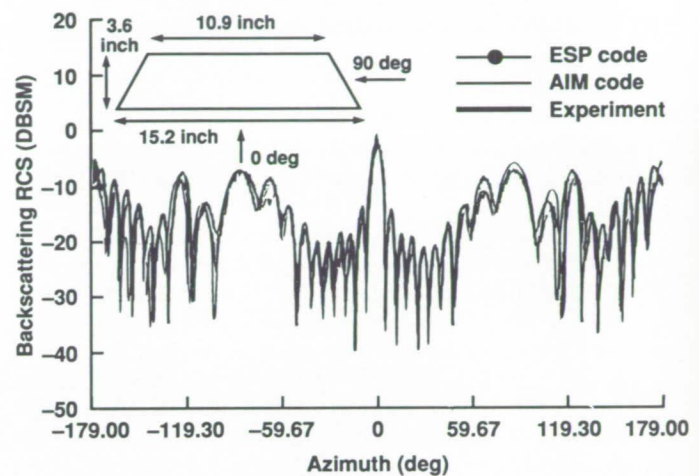

Back scattering from a perfectly conducting trapezoidal plate illuminated by a transverse magnetic polarized grazing wave,  $f = 3.5$  GHz.

# Turbulent Premixed Combustion

Arnaud Trouvé, Principal Investigator

Co-Investigator: Thierry Poinsot

NASA Ames Research Center/Stanford University

## Research Objective

To use direct numerical simulation (DNS) to increase the basic understanding of flame–turbulence interactions with primary interest in Reynolds-averaged models for turbulent combustion.

## Approach

DNS applied to turbulent combustion solves the full Navier–Stokes equations and uses a reduced chemical scheme to model the combustion processes. In this study, the chemical model is a single-step irreversible finite-rate chemical reaction. The numerical code is a three-dimensional high-order finite-difference code. The code can treat non-period domains, and accounts for compressibility effects and thermal expansion of the reacting flow due to heat release.

## Accomplishment Description

We completed (1) a flame–vortex interaction problem used to construct turbulent diagrams to predict the occurrence of flame quenching and to propose a new definition of the flamelet regime, (2) a model problem of curved flame elements to investigate the influence of curvature on the structure of the reaction zone, and (3) a premixed flame problem with a non-unity Lewis number embedded in isotropic turbulence to assess the effects of strain rate and flame curvature on the structure of the reaction zone. Recent simulations include premixed flames in isotropic turbulence and linear turbulent–shear flows to assess the effects of the turbulence structure on the flame response (see the accompanying figure), and flame ignition in isotropic turbulent flows to describe and help model the early growth of a flame kernel and its transition to turbulent flame propagation. Two-dimensional computations required 10 Cray Y-MP hours and 8 megawords of memory. Three-dimensional computations required 80 Cray Y-MP hours and 16 megawords of memory.

## Significance

Flamelet models constitute the most common approach for premixed turbulent combustion. The validity of these models was investigated and most practical situations are likely to satisfy the basic assumptions used in the flamelet approach. The role of flame curvature was clarified and, while curvature determines the local characteristics of the reaction zone, global space-averaged features do not require curvature effects and are captured by predictions based on the stagnation point flame picture.

## Future Plans

We will continue to use a more refined chemical model to capture important physical phenomena like chemical-kinetic extinction and pollutant formation. We will investigate the modeling of the flame surface density under various mean flow-field configurations to assess the effects of mean flow convection on the flame wrinkling.

## Publications

1. Poinsot, T.; Veynante, D.; and Candel, S. “Quenching Processes and Premixed Turbulent Combustion Diagrams.” *J. Fluid Mech.* 228 (1990): 561–605.
2. Meneveau, C. and Poinsot, T. “Stretching and Quenching of Flamelets in Premixed Turbulent Combustion.” *Combustion and Flame* 86 (1990): 311–332.
3. Poinsot, T. and Mungal, G. “A Study of the Laminar Flame Tip and Implications for Premixed Turbulent Combustion.” *Combustion Science and Technology* 81 (1992): 45–73.

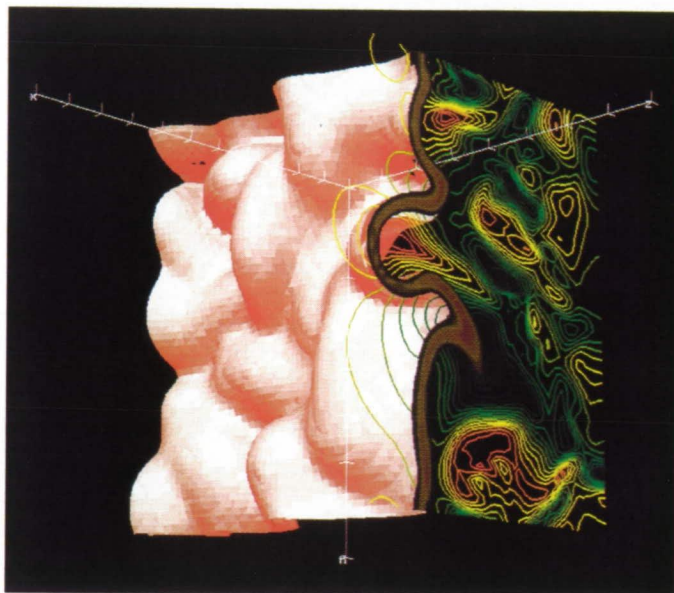

*Direct numerical simulation of a premixed flame in three-dimensional isotropic turbulence. Contours of the reaction rate and velocity field are shown. Fresh reactants are at the back of the plot; burnt products are at the front. Grid size = 1,283; turbulent Reynolds number = 20; Damkohler number = 1.*

# Multigrid Solution of the Navier–Stokes Equations

Eli Turkel, Principal Investigator  
ICASE/NASA Langley Research Center

## Research Objective

To develop an efficient solver for the steady-state compressible Navier–Stokes equations at all speeds by utilizing multigrid techniques.

## Approach

A three-dimensional central-difference code was used in generalized coordinates. An artificial viscosity was added and was constructed as a total-variation-diminishing scheme for a scalar one-dimensional equation. The equations are advanced in time using a multistage formula. In addition, local time-stepping, residual smoothing, and multigrid techniques were used to accelerate the convergence to a steady state. A standard FMG-FAS multigrid was used for hypersonic flows. The code contains standard algebraic turbulence models that are used for comparisons with experiments.

## Accomplishment Description

The code has been used to solve many problems in subsonic, transonic, supersonic, and hypersonic flow regimes. Multigrids have been used to accelerate the convergence rates in all the flow regimes. In particular, biconic and High-Speed Civil Transport configurations have been used and the results of the code have compared favorably with experimental results. Even for hypersonic flow with viscous and turbulent terms, the scheme converges rapidly with a typical residual reduced by three to four orders of magnitude within 300 Runge–Kutta

cycles. A medium size mesh is  $129 \times 97 \times 25$ , and 250 cycles on the finest mesh requires about 2 Cray-2 hours and requires about 20 megawords of memory.

## Significance

A code has been developed to efficiently solve flow around aerodynamic bodies and is presently being used by several groups around the country.

## Future Plans

The code will be generalized to include chemistry and geometric configurations. An incompressible version is also being developed.

## Publications

1. Vatsa, V. N.; Turkel, E.; and Abolhaseni, J. S. "Extension of Multigrid Methodology to Supersonic/Hypersonic Three-Dimensional Viscous Flows." Presented at 5th Copper Mountain Conference on Multigrid Methods, 1991.
2. Turkel, E.; Swanson, R. C.; Vatsa, V. N.; and White, J. A. "Multigrid for Hypersonic Viscous Two- and Three-Dimensional Flows." *AIAA 10th CFD Conference*. (1991): 501–517.
3. Jorgenson, P. and Turkel, E. "Central Difference TVD and TVB Schemes for Time-Dependent and Steady-State Problems." *AIAA Paper 92-0053*, 1992.

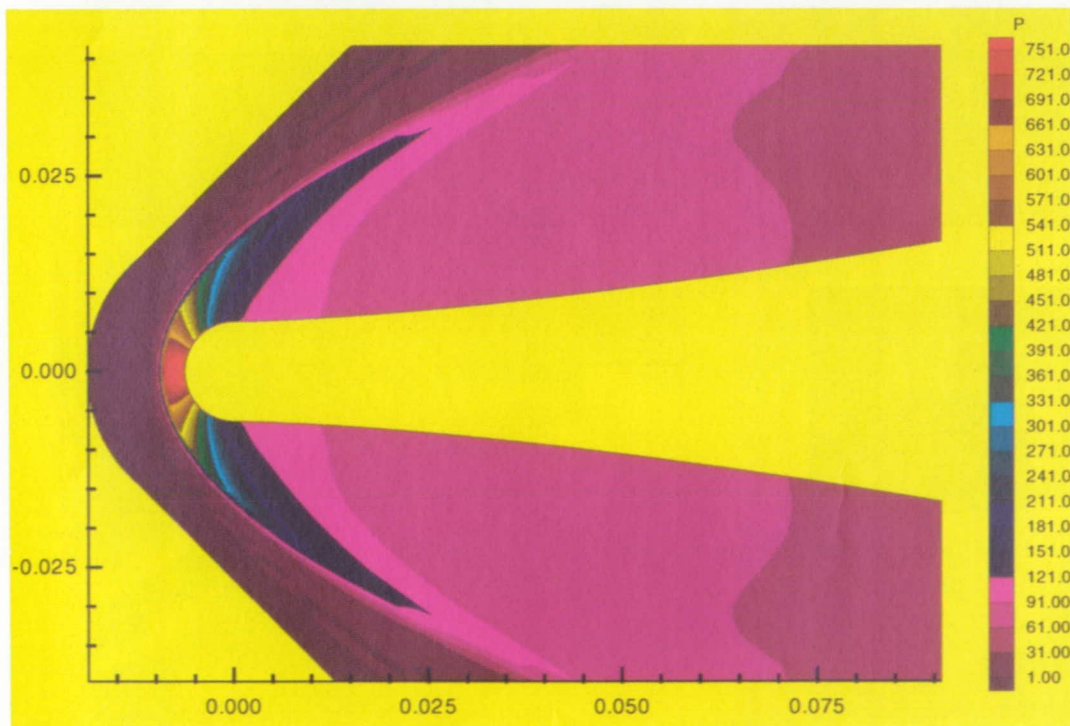

Turbulent flow about a blunt cone; Mach = 25.0.

# Multi-Element High-Lift Concepts

Walter O. Valarezo, Principal Investigator  
Co-Investigators: Vincent D. Chin and Dimitri J. Mavriplis  
Douglas Aircraft Company/NASA Langley Research Center/ICASE

## Research Objective

To calibrate a two-dimensional unstructured-grid Reynolds-averaged Navier–Stokes method for multi-element high-lift configurations.

## Approach

The method uses multigrid techniques to enhance computational efficiency and, due to its unstructured mesh approach, is well suited for the complex high-lift geometries of transport aircraft. A Baldwin–Lomax turbulence model is utilized.

## Accomplishment Description

The present method has been applied to a three-element airfoil configured for landing. The leading-edge slat and trailing-edge flap are both deflected 30 degrees. We compared our predictions to available experimental data obtained at chord Reynolds numbers from  $5 \times 10^6$  to  $10 \times 10^6$ . Studies were conducted to assess predicted performance increments for variations in flap deflection angle and flap positioning (including gap and overhang). Results obtained indicated good general agreement

with experiment, but changes in lift due to gap and overhang adjustments were inconsistent with experiment. The code successfully predicted separated-flow regions behind the slat and in the flapwell (see accompanying figure), but did not predict flow separation on the flap suction surface. A total of 175 Cray-2 hours were used for this calibration.

## Significance

The development of multi-element high-lift systems, which are simpler, but exhibit higher performance than previous generation designs, has been identified as a high priority in the transport aircraft industry. The timely development of advanced high-lift airfoils should be favorably impacted by the application of suitable computational methods.

## Future Plans

Work will focus on the effect of more sophisticated turbulence models on the predictive capability of this method. The ability to numerically predict maximum lift remains a goal.

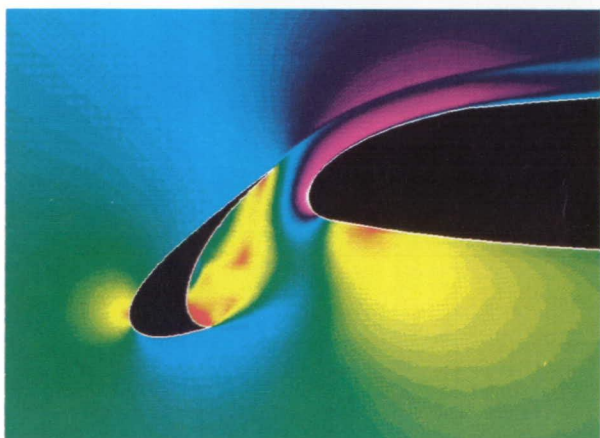
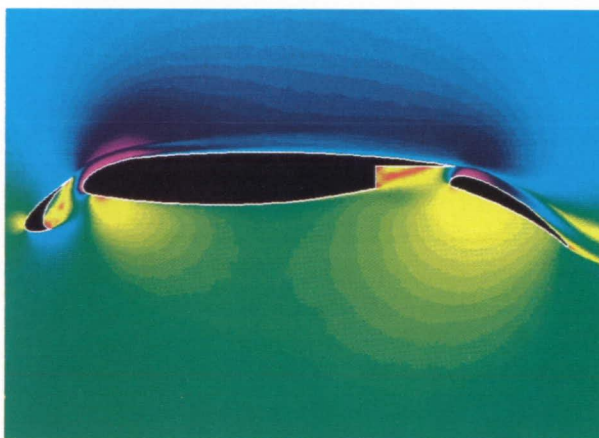
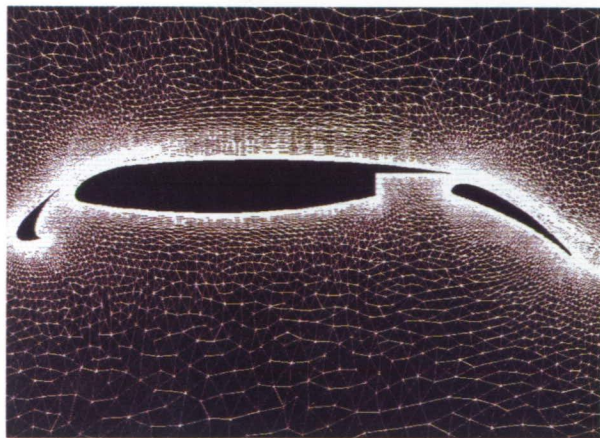

Unstructured grid and Mach number contours for a transport airfoil. Higher than free stream is indicated by the color pink.

# Simulation of the Unsteady Flow about Transonic Cavities

W. R. Van Dalsem, Principal Investigator

Co-Investigators: C. A. Atwood, S. P. Klotz, and D. Sondak  
NASA Ames Research Center/MCAT Institute

## Research Objective

To demonstrate and validate computational fluid dynamics capabilities as applied to the Stratospheric Observatory for Infrared Astronomy (SOFIA). Numerical evaluation of the fluid and optical fields, in addition to experimental results, will provide a means to evaluate configurations in a timely and cost effective way.

## Approach

The use of the Pulliam-Chaussee diagonal algorithm within a three-dimensional Reynolds-averaged overset mesh Navier-Stokes code has shown that resonant frequencies and magnitudes have been accurately captured in comparison to experiment. These results were found through simulations of a steady-state solution of the flow field about the wind tunnel configuration, a strongly resonating solution of the cavity, and an acoustically quiet solution including the telescope geometry. The final simulation in the series required the use of 1.8 million cells distributed over 15 grids. The time-varying density field was used to determine the optical clarity of the shear layer. Efficient computation of this series of configurations was accomplished using the steady-state solution as the initial condition for the unsteady cases. For this problem the unsteadiness was limited to a domain immediately surrounding the cavity. This property was used to advantage by iterating only the grids that fell in this region. Computation required 16 megawords of memory and 100 single-processor Cray Y-MP hours with the solid-state storage device.

## Accomplishment Description

Simulations of complex flows over realistic geometries have demonstrated the effectiveness of numerical methods for this class of cavity problems. Agreement with experiment in frequency, magnitude, and spatial variation of the loads is generally within 5%. Computed optical distortion trends correctly, but underpredicts experiment.

## Significance

The results of these simulations are impacting SOFIA design and unsteady telescope loads have been provided to the design group.

## Future Plans

A sizable reduction in aircraft cost would be realized if the telescope were mounted aft of the wing. However, the proposed aft installation would incur potentially adverse effects on empennage loads and seeing capabilities. During the next year, we will address these issues.

## Publication

Atwood, C. A. and Van Dalsem, W. R. "Flow-Field Simulation about the SOFIA Airborne Observatory." AIAA Paper 92-0656, 30th Aerospace Sciences Meeting and Exhibit, Reno, NV, Jan. 1992.

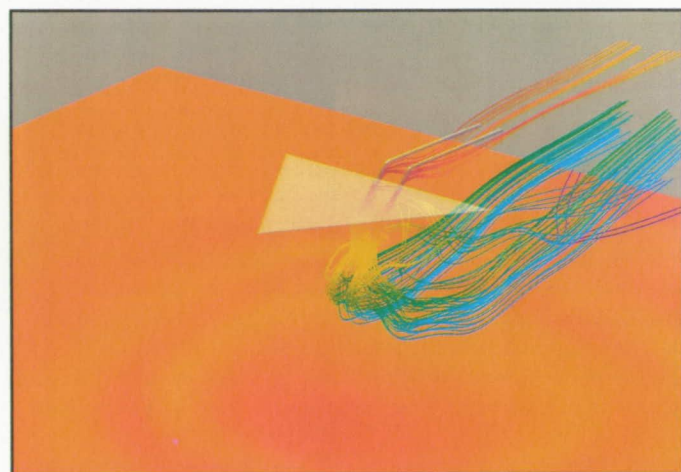
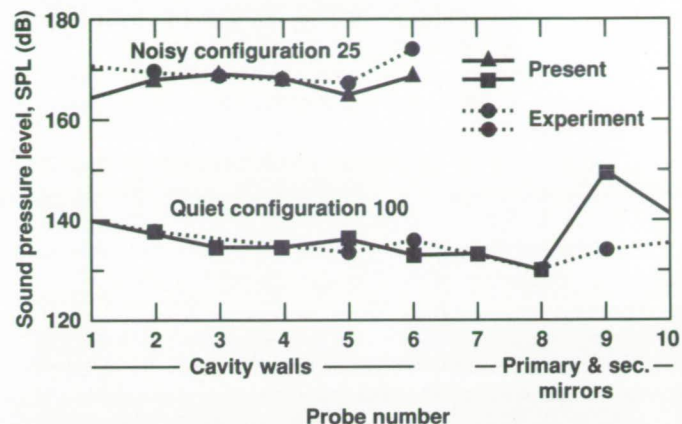

Summary of 1991-92 NAS Operational Year Stratospheric Observatory for Infrared Astronomy results.

# Powered-Lift Computational Fluid Dynamics Project

W. R. Van Dalsem, Principal Investigator  
Co-Investigator: K. Chawla  
NASA Ames Research Center/MCAT Institute

## Research Objective

To simulate a powered-lift configuration in descent to understand the differences in flow physics that result as a variation in lift loss and to use this capability to simulate a full configuration.

## Approach

Using the simplified configuration of a delta wing with thrust-reverser jets, we will simulate a powered-lift descent. We will solve the three-dimensional unsteady Navier–Stokes equations on overset/patched grid systems using OVERFLOW's diagonalized option and use the domain connectivity function to communicate solutions across grids and to descend the delta wing.

## Accomplishment Description

Numerical simulations of the flow about a 60 degree delta planform wing flying at Mach 0.064, and a Reynolds number of 1.2 million, equipped with two sonic thrust-reverser jets exiting from jet pipes, were performed at a height of about one wing-span above the ground. The converged solution was used to begin the descent of the delta wing from this height toward the final height of about one-quarter wing-span above the ground. Converged solutions were also obtained at heights of one-half and one-quarter wing-spans above the ground to compare against the dynamic case.

## Significance

Analysis of solutions from the simulation of a powered-lift delta wing in descent will shed light on the mechanisms by which lift loss varies for the static and the dynamic cases. The capability to simulate accurate lift-loads will allow prediction of minimum hover height for a powered-lift aircraft. Also, the solution of this simplified configuration will point out the bottlenecks, such as slow input/output and lack of methods for visualization and analysis of large amounts of unsteady data, that must be resolved before full configuration simulations can be routinely performed.

## Future Plans

We will finish the descent simulation and analyze the results to understand the differences in flow physics in the static and the dynamic cases. Knowledge gained in this work will be used to simulate a full-configuration powered-lift landing.

## Publication

Chawla, K. and Van Dalsem, W. R. "Numerical Simulation of STOL Operations using Thrust Reversers." AIAA Paper 92-4254, AIAA Aircraft Design Systems Meeting, Hilton Head, SC, Aug. 1992.

## SOFIA: Stratospheric Observatory For Infrared Astronomy Instantaneous Mach and Cp Contours

$Re = 4 \times 10^6 / ft.$   
 $M_\infty = 0.85$   
 $\alpha = 2.5^\circ$

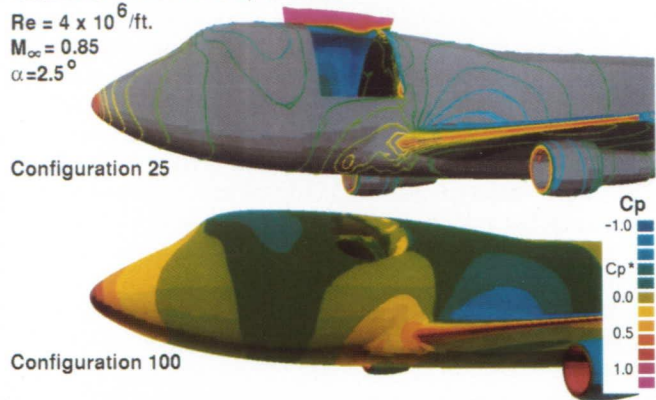

*A descending delta wing with thrust reverser jets. The ground is colored by the pressure coefficient (notice the ripple effect even before the jets have reached the ground); particle traces are colored by height.*

# High-Reynolds-Number Viscous Flow over Aircraft Components

Veer N. Vatsa, Principal Investigator  
Co-Investigator: Eli Turkel  
NASA Langley Research Center

## Research Objective

To develop an efficient, accurate, and robust numerical procedure for computing high-Reynolds-number viscous flow over aircraft components.

## Approach

A multistage Runge-Kutta time-stepping scheme with multigrid acceleration technique is extended to solve supersonic and hypersonic flows. A study is being conducted to assess the accuracy of predicted heat-transfer loads.

## Accomplishment Description

A multigrid-based finite-volume numerical scheme developed for computing aerodynamic flows over aircraft components in the transonic-flow regimes has been extended to solve supersonic and hypersonic flows. The numerical code, TLNS3D, is one of the most efficient codes available today for solving viscous flows in the transonic-flow regime and is known for accurate prediction of aerodynamic loads. An attempt was made to calibrate the TLNS3D code for predicting heat transfer loads for high Mach-number flows. The flow over a modified shuttle orbiter at Mach 6 and 30 degrees angle of attack was used as a test case. Approximately 3 Cray Y-MP hours were required to get a converged solution for this configuration on a mesh consisting of approximately 82,000 nodes. As shown in the accompanying figure, the computed heat-transfer-coefficient distributions compare well with the experimental data and calculations from an upwind-based Navier-Stokes solver.

## Significance

It appears that the present code can accurately predict the heat loads for supersonic (Mach 6) flows, resulting in an order-of-magnitude reduction in computer time compared to non-multigrid codes currently in use.

## Future Plans

The method will be generalized to accommodate block-structured grids so that flow over complex aircraft configurations can be computed.

## Publication

Vatsa, V. N. "Evaluation of a Multigrid-Based Navier-Stokes Solver for Aerothermodynamic Computations." AIAA Paper 92-4563, 1992.

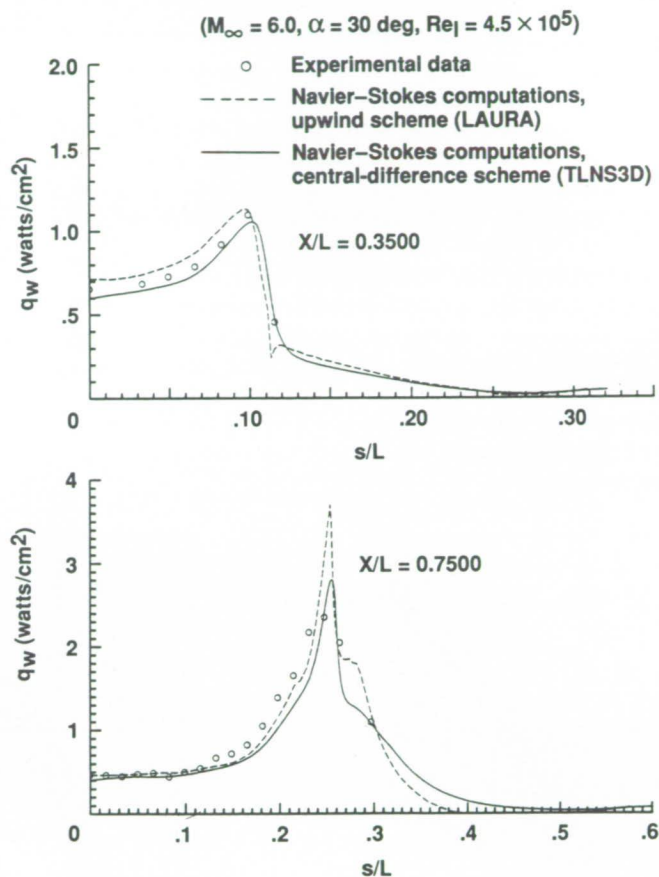

Comparison of surface heat transfer distributions for a modified shuttle orbiter;  $M_\infty = 6.0$ ,  $\alpha = 30$  degrees,  $Re_l = 4.5 \times 10^5$ .

# Two-Equation Turbulence-Model Implementation

Gururaja R. Vemaganti, Principal Investigator  
Lockheed Engineering and Sciences Company

## Research Objective

To implement a two-equation turbulence model in an unstructured grid solver and investigate the turbulent shear-layer effects in a shock–shock interference pattern developed in a hypersonic flow over a blunt body.

## Approach

Severe aerodynamic heating caused by a shock–shock interference pattern in a hypersonic flow over a blunt body is a critical information needed to design an aerospace vehicle. Due to the flow complexities, unstructured meshes are preferred for this class of problems because of their mesh adaptation capabilities. In order to resolve the effects of free-stream turbulence on the flow field and the growth of a turbulent shear layer that is developed due to type III and type IV interactions, a two-equation turbulence model with built-in compressibility effects was implemented in the NASA Langley adaptive remeshing code Navier–Stokes solver (LARCNESS) algorithm, which is an unstructured grid solver. In this algorithm, the six governing equations (the four mean flow equations and two turbulence equations) are solved simultaneously based on a point-implicit upwind method.

## Accomplishment Description

The LARCNESS algorithm with the two-equation turbulence model is validated against analytical and numerical data for a flow over a flat plate and a free-shear-layer flow. The behavior of the turbulence variables near the shocks was predicted to be similar to that of other methods. A type III shock–shock interaction problem in a Mach 8.03 flow over a cylinder is currently being investigated. To perform three successive remeshings and obtain a converged solution on the last mesh takes about 1 Cray-2 hour.

## Significance

This research is performed as a part of a government work package related to the National Aero-Space Plane (NASP). Once the algorithm is validated against experimental data, it is used to predict the aerodynamic heating under NASP flight conditions.

## Future Plans

Future plans include simulation of type III and type IV shock–shock interference patterns in comparison to the experiments to be performed at Mach 15 over a cylinder.

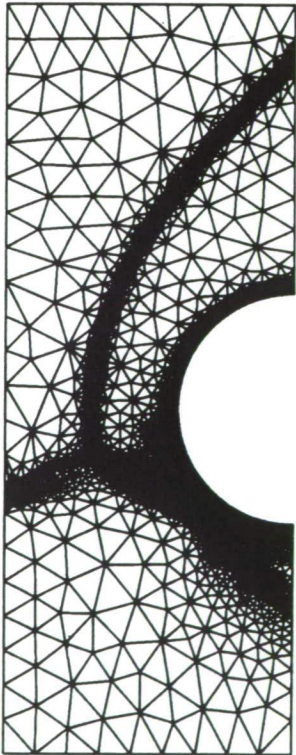

(a) Adapted unstructured grid for the shock interaction problem



(b) Turbulent kinetic energy distribution



(c) Turbulent dissipation rate distribution

*Two-equation turbulence-model implementation in an unstructured grid solver.*

# Tactical Missile Aero-Propulsion Interaction

Bill J. Walker, Principal Investigator

Co-Investigators: C. D. Mikkelsen, K. D. Kennedy, P. F. Booth, and M. E. Vaughn, Jr.

U.S. Army Missile Command

## Research Objective

To develop the capability to model missile-plume flow fields, including (1) aerodynamic flow separation of the missile afterbody boundary layer due to the high pressures at the rocket nozzle exit plane; (2) the recirculation, mixing, and chemical reaction in the base region; (3) the mixing, shock structure, and after burning of the fuel-rich rocket exhaust in the near-plume region; and (4) the mixing in the far-plume region.

## Approach

We are simultaneously solving the fluid-dynamic conservation equations, turbulence-model equations, two-phase gas-particle interaction equations, and the chemical-kinetics equations using proven numerical methods of computational fluid dynamics.

## Accomplishment Description

PARCH, a three-dimensional Navier-Stokes flow-field solver with two-equation turbulence models, finite-rate chemistry, and a two-phase flow capability, has been developed and run against a set of high-quality, plume flow-field code-validation data. The accompanying figure shows the flow-field Mach number for an

axisymmetric, Mach 2.4 air jet into a Mach 1.4 co-flowing airstream. Overlaid on the flow field are radial profiles at an axial location two radii downstream from the nozzle exit plane that compare laser-Doppler-velocimeter measurements for axial velocity, radial velocity, and turbulence kinetic energy with PARCH Navier-Stokes model calculations and calculations for the spatial marching standardized plume flow-field model. This case required 20 Cray-2 hours and 32 megawords of memory.

## Significance

The basic methodology now exists to numerically model and predict the complex chemically-reacting and two-phase flow fields for missiles with propulsive rocket exhaust plumes. This methodology, when fully validated, will provide invaluable missile design information that cannot be acquired in wind tunnels due to capability, safety, or cost.

## Future Plans

Efforts will focus on validation of the model with experimental plume flow-field data for species and temperature.

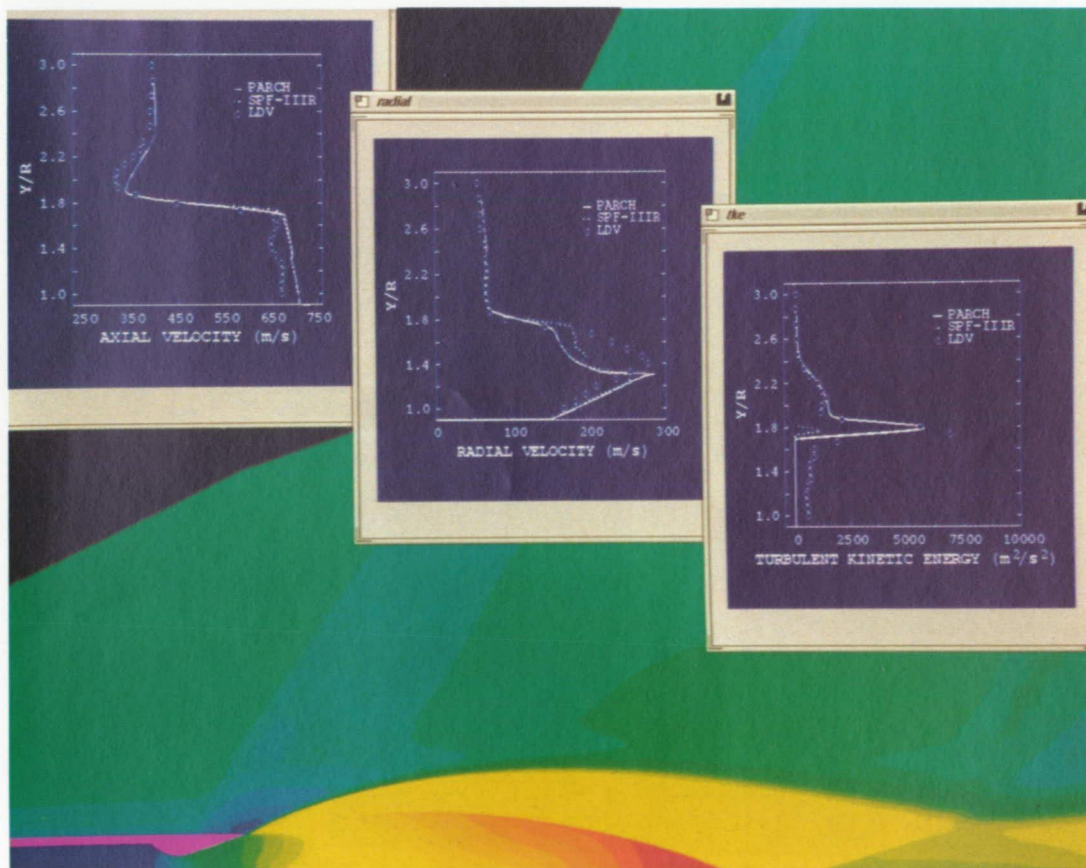

Flow-field Mach number for a Mach 2.4 air jet into a Mach 1.4 co-flowing airstream with comparisons of model calculations and laser-Doppler-velocimeter validation measurements.

# Finite-Rate Chemistry Algorithms

Robert W. Walters, Principal Investigator

Co-Investigators: Bernard Grossman, Michael Applebaum, Andrew S. Godfrey, William D. McGrory, and David C. Slack  
Virginia Polytechnic Institute and State University

## Research Objective

To develop and validate simulation tools capable of performing complete tip-to-tail analysis including internal and external flow-field calculations.

## Approach

A three-dimensional implicit upwind Navier–Stokes code with generalized chemistry and vibrational nonequilibrium thermodynamics models is used to predict the flow field about hypersonic vehicles and in propulsion systems.

## Accomplishment Description

We have been developing a new version of the General Aerodynamic Simulation Program (GASP) code with new features and improvements, particularly in memory and run time for three-dimensional elliptic problems. As a separate task, we are developing a preconditioning strategy to extend the applicability of a compressible Navier–Stokes code to the incompressible regime while improving steady-state convergence across the Mach number range. We are extending the k-exact reconstruction process to handle discontinuities on unstructured grids. A typical calculation takes 5–10 hours and 10–30 megawords of memory. We recently submitted GASP 1.3a results for the Third JANNAF Combustion Workshop problem. The results were of the turbulent flow over a rearward facing step with two normal injectors. On a two-zone grid with a total of 266,090 grid points, GASP 1.3a required 4.5 hours and 32 megawords of memory.

Our new version runs this same problem in 50 minutes and needs 6.5 megawords of memory. The accompanying figure shows particle traces in the recirculation and injection regions superimposed on pressure contours in the symmetry plane.

## Significance

The need to accurately simulate a wide range of three-dimensional fluid-dynamic problems with complex physics, including turbulence and finite-rate chemistry models, is required for hypersonic vehicle design, propulsion system analysis, and a number of strategic defense problems.

## Future Plans

We are investigating and coupling inverse design techniques for supersonic and hypersonic forebody design. In addition, we are developing preconditioning techniques for convergence acceleration and we are continuing our unstructured flow-solver effort.

## Publications

1. Walters, R. W.; McGrory, W. D.; and Slack, D. C. "GASP 1.3." Third JANNAF Workshop on Scramjet Combustion Modeling, Reno, NV, Jan. 1992.
2. Godfrey, A.G.; Mitchell, C. R.; and Walters, R. W. "Practical Aspects of Spatially High Accurate Methods." AIAA Paper 92-0054, Jan. 1992.

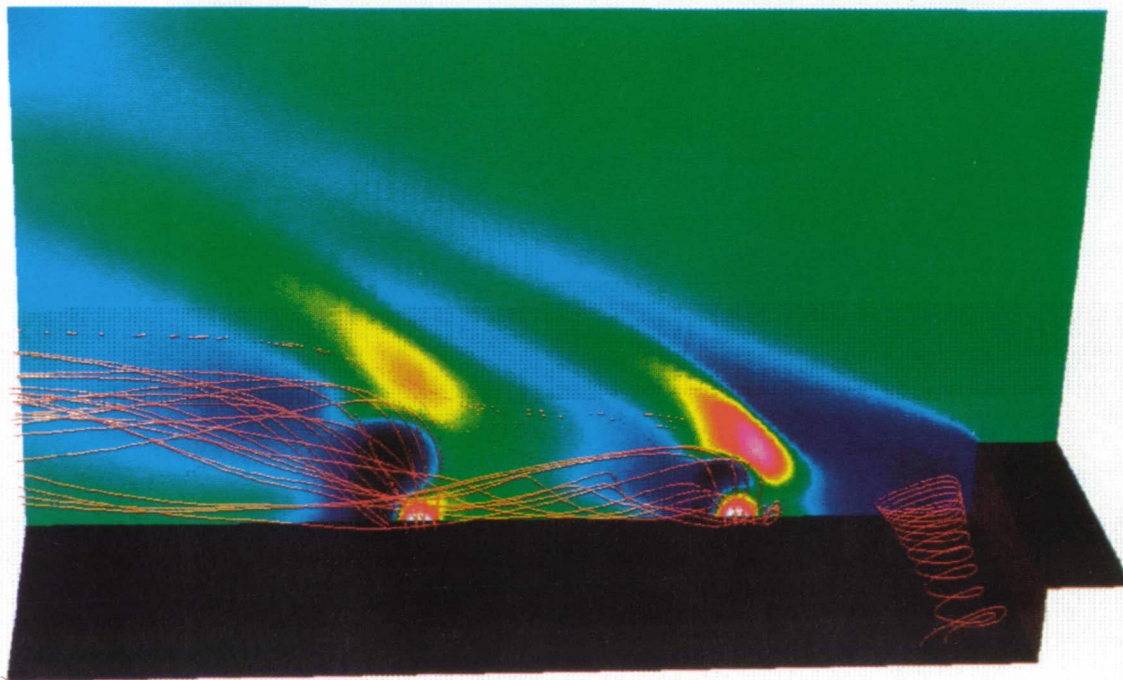

*Particle traces superimposed on pressure contours in the symmetry plane.*

# Hydrocarbon Scramjet Combustor Flows

Jong H. Wang, Principal Investigator  
Rockwell International, North American Aircraft Division

## Research Objective

To validate Navier–Stokes methodology for predicting hydrocarbon scramjet combustor flows.

## Approach

The unified solution algorithms code is applied to existing combustor-flow test cases to validate the code and provide direction for future development of numeric and chemistry models.

## Accomplishment Description

A Rocketdyne dual-mode hydrocarbon scramjet combustor was numerically investigated. The fuel–air ratio was increased with time from 0–1 by six steps with each one reaching a steady-state condition. The normal and tangential fuel injectors were distributed at various combustor stations. The problem was modeled as a two-dimensional quasi-steady-state flow with the fuel-injector opening adjusted for the correct mass-flow rate. A 27,046-grid system was used and a global-reaction chemistry model was assumed for the oxidation of ethylene, silane, and hydrogen fuels used in the combustor. The problem took 5.27 Cray Y-MP seconds per iteration and the solutions took 2–4 hours to converge between two different flow conditions and required 3 megawords of memory. The predicted combustor Mach-number contours and the detailed flow fields adjacent to the backward-facing steps are shown in the accompanying figures. The Mach numbers for the combustor inlet and exit are 1 and 2, respectively. The sudden changes of the Mach numbers are due to either the injection of the fuel or the change of the combustor geometry. The flow in the combustor is quite complicated and the pressure waves generated by the separation bubbles behind the top and bottom steps interact with each other and create interesting Mach contour patterns. The predicted wall static pressure was in good agreement with experimental data except for a small region where the three-dimensional flow effects were important. The predicted combustor thrusts for different fuel–air ratios were also in reasonable agreement with experimental data. The agreement between predictions and data were excellent for fuel–air ratio below 0.76. For a higher ratio, the predictions began to deviate from the data due to the three-dimensional flow effects or the limitation of the present global-reaction chemistry model.

## Significance

The design of an efficient hypersonic combustor is essential to the success of an air-breathing hypersonic vehicle. The complexity of the flow physics and the requirement to obtain efficient mixing and combustion require an accurate and robust computational tool.

## Future Plans

This research will be extended to study realistic three-dimensional combustor flows with the effect of various hydrocarbon fuel-oxidation models.

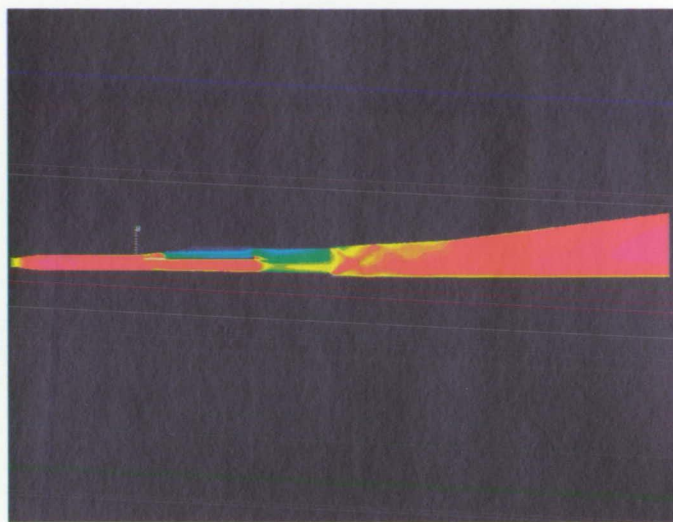

*Mach-number contours.*

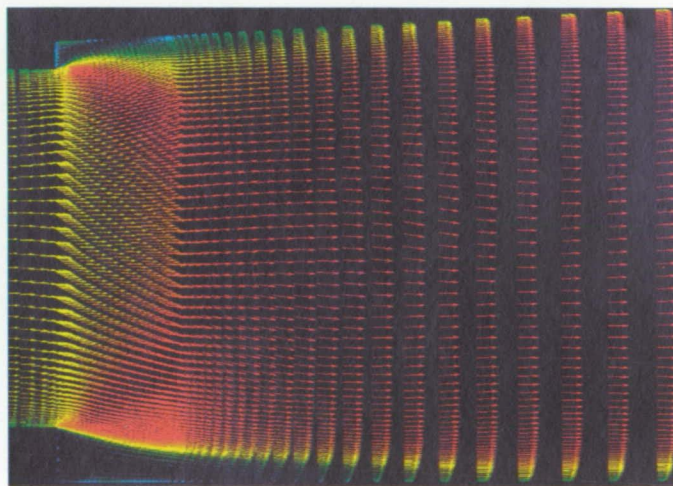

*Velocity vectors colored with Mach number for the flow behind the backward-facing steps.*

# Flow Simulation in Fan and Core Compressor Stages

Kurt F. Weber, Principal Investigator

Co-Investigator: Dale W. Thoe

General Motors Corporation, Allison Gas Turbine Division

## Research Objective

To validate a Navier–Stokes code that simulates the flow through transonic fan and core compressor stages. The analysis must operate in a multistage environment and provide a detailed description of important phenomena, including the interaction of the tip-clearance flow and the blade-passage throughflow.

## Approach

We applied a fully viscous three-dimensional finite-difference code to the solution of compressor and fan flow fields, applied domain decomposition, and used multiple grids and multiple-grid types. For a fan stage, the blade-passage flow fields are solved on body-conforming O-grids, and the tip-clearance flow field is solved on a fine H-grid embedded in the clearance region. H-grids can be placed in the inter-blade-row region and upstream from the rotor. The equations are solved using the implicit approximate-factorization Beam–Warming algorithm. Flow-field data are interpolated between grids using the Chimera grid-embedding technique.

## Accomplishment Description

A three-dimensional embedded-grid Navier–Stokes code, which utilizes blade-conforming O-grids and embedded H-grids, has been applied to simulate transonic compressor flows, including the coupling of rotor and stator flows and tip-clearance modeling. The implicit solver uses Pulliam’s pentadiagonal version of the Beam–Warming algorithm. The code accounts for multiple embedded grids and works with the output from the multiple-grid data management code PEGASUS. Fully viscous solutions with a very fine H-grid embedded in the clearance region have been calculated for several rotors, including NASA rotor 67. A fully viscous calculation for NASA stage 67 has been completed. The solutions show good agreement with laser-Doppler-anemometer measurements. The finest grid solution for NASA stage 67 contained 437,999 points in the rotor O-grid and 58,890 points in the embedded H-grid. The accompanying figure shows a close-up view of a tip-clearance vortex formation near the leading edge of NASA rotor 67 at the peak-efficiency operating point. The blade surface is colored by pressure contours and the particle traces are released in the clearance region close to the blade tip. This solution used 21 megawords of memory and required 14.2 Cray-2 hours for 2,500 iterations.

## Significance

The use of three-dimensional flow codes for aerodynamic design improvements in aircraft gas-turbine engine compressors and fans has become more widespread. However, the level of accuracy has not been high enough to significantly reduce the amount of testing required. Major performance improvements or significant cost reductions are unlikely unless the three-dimensional analyses focus on flow-field resolution and calculation accuracy.

## Future Plans

The existing code accounts for multiple-overset or embedded grids. This will be used to extend the application to simulate a turbofan-engine low-pressure compression-system flow field.

## Publication

Weber, K. F. and Delaney, R. A. “Viscous Analysis of Three-Dimensional Turbomachinery Flows on Body-Conforming Grids using an Implicit Solver.” ASME Paper 91-GT-205, ASME International Gas Turbine Exposition, Orlando, FL, June 1991.

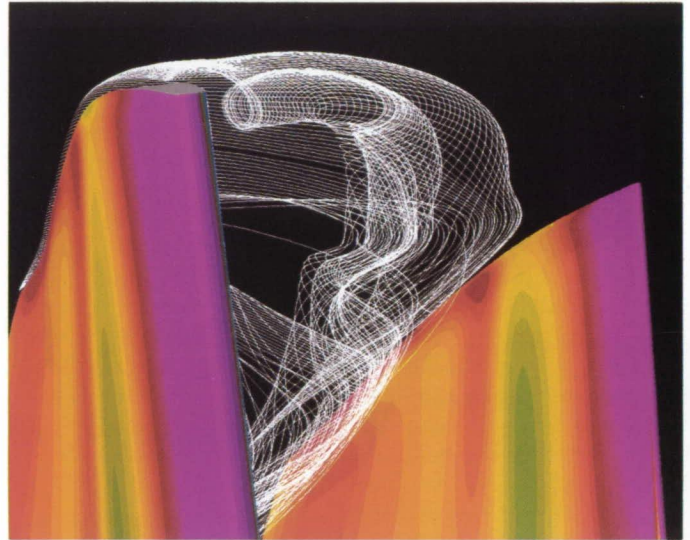

*Close-up view of the formation of a tip-clearance vortex.*

# Winged Entry-Vehicle Computations

Kenneth J. Weilmuenster, Principal Investigator  
Co-Investigators: Francis A. Greene and William L. Kleb  
NASA Langley Research Center

## Research Objective

To develop a solution for the viscous thermal non-equilibrium flow-field computation about winged vehicles at hypersonic speeds.

## Approach

The Halis shuttle model, which combines an accurate description of the lower surface of the shuttle orbiter with a simplified leeside geometry, was used as the configuration in this study. Two viscous volume grids having 145 axial planes, with 81 points in each cross section and 41 and 81 points between the body and out boundary, were constructed. Each volume grid was divided into four blocks as shown in the accompanying figure. The procedure is to solve each block, independent of the other, using the solution on the downstream boundary of the previous block as the upstream boundary condition for the solution in the adjoining downstream block, thus reducing a very large job in terms of memory and time to a series of more manageable smaller jobs. The Langley Aerothermodynamics Upwind Relaxation Algorithm has been used for the flow-field computations.

## Accomplishment Description

The viscous thermochemical nonequilibrium flow field about a winged entry vehicle at hypersonic speeds has been computed using a streamwise block by block marching technique. A comparison of computed windward centerline heating with data from three different flights, shown in the accompanying figure, indicates that this procedure yields excellent results.

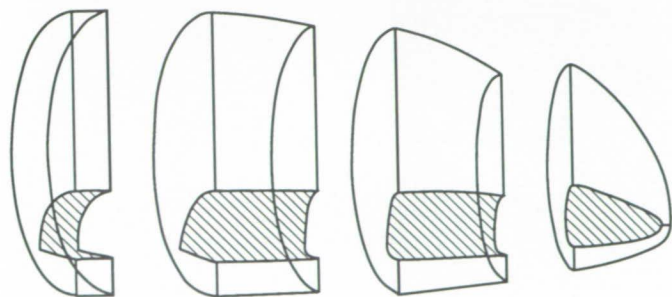

Volume grid divided into four blocks.

## Significance

By showing that a large problem such as this can be solved by breaking it into parts, the solution for flow over complex configurations becomes more realistic. A solution on the complete  $145 \times 81 \times 81$  grid used in the problem would require 240 megawords of memory. A configuration with a complex leeside geometry might require 2-4 times that much memory and makes the blocking technique used here the only reasonable option.

## Future Plans

This blocking technique will be applied to the complete shuttle-orbiter geometry to access the vehicle's aerodynamics at hypersonic speeds. Particular attention will be given to identifying the flow characteristics which caused the unexpected aerodynamics encountered by the vehicle in flight at hypersonic speeds.

## Publication

Weilmuenster, K. J. and Gnoffo, P. A. "Solutions, Strategies, and Heat Transfer Calculations for Three-Dimensional Configurations at Hypersonic Speeds." AIAA Paper 92-2921, July 1992.

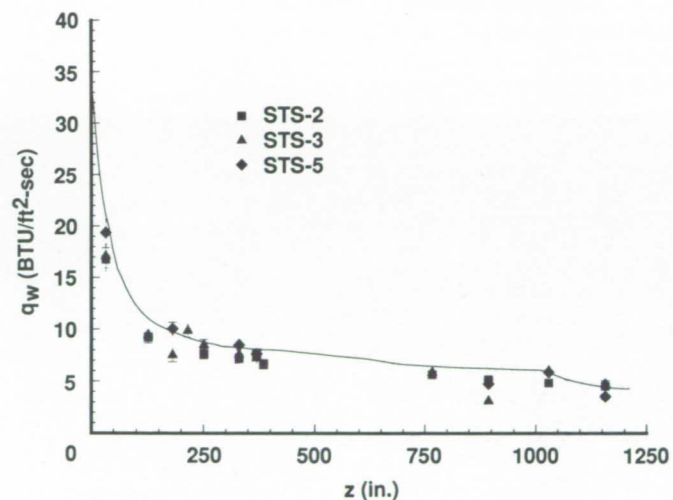

Comparison of computed windward centerline heating with data from three different flights.

# Shuttle Leeside Temperature Study

Kenneth J. Weilmuenster, Principal Investigator  
Co-Investigator: William L. Kleb  
NASA Langley Research Center

## Research Objective

To define the computational resources and solution techniques required to define the leeside flow over the shuttle orbiter.

## Approach

Surface temperatures on the leeside of the Orbiter at hypersonic flight conditions have been measured by the Shuttle Infrared Leeside Temperature Study (SILTS). The SILTS data base has been used to access the validity of the computed results.

## Accomplishment Description

Significant work was required to establish an acceptable volume grid for this computation. Software to define surface and grid quality and techniques to accelerate the convergence of existing elliptic solvers was developed to meet the requirements of this project. The Langley Aerothermodynamics Upwind Relaxation Algorithm code was used for the solution. The viscous thermochemical nonequilibrium solution incorporated variable wall temperature, a catalytic surface, and the dependence of emissivity on temperature. The accompanying figure shows a comparison of the computed leeside surface temperature (top half) and the measured surface temperatures (lower half) from STS-32 at  $M_\infty = 24$  and 40 degrees angle of attack. The SILTS data base is limited by the field of view of the infrared camera used in the experiment.

## Significance

The figure shows that the computed temperatures are in good agreement with those measured in flight. Current computational techniques are capable of adequately accessing the temperature and heating environment on the leeside of a winged entry vehicle at hypersonic speed and high angles of attack.

## Future Plans

While the comparison with data on the upper surface of the wing is good, there are differences between data from thermocouples located on the side and top centerline of the vehicle. We will continue to resolve those differences.

## Publication

Kleb, W. L. and Weilmuenster, K. J. "Characteristics of the Shuttle Orbiter Leeside Flow During a Reentry Condition." AIAA Paper 92-2951, July 1992.

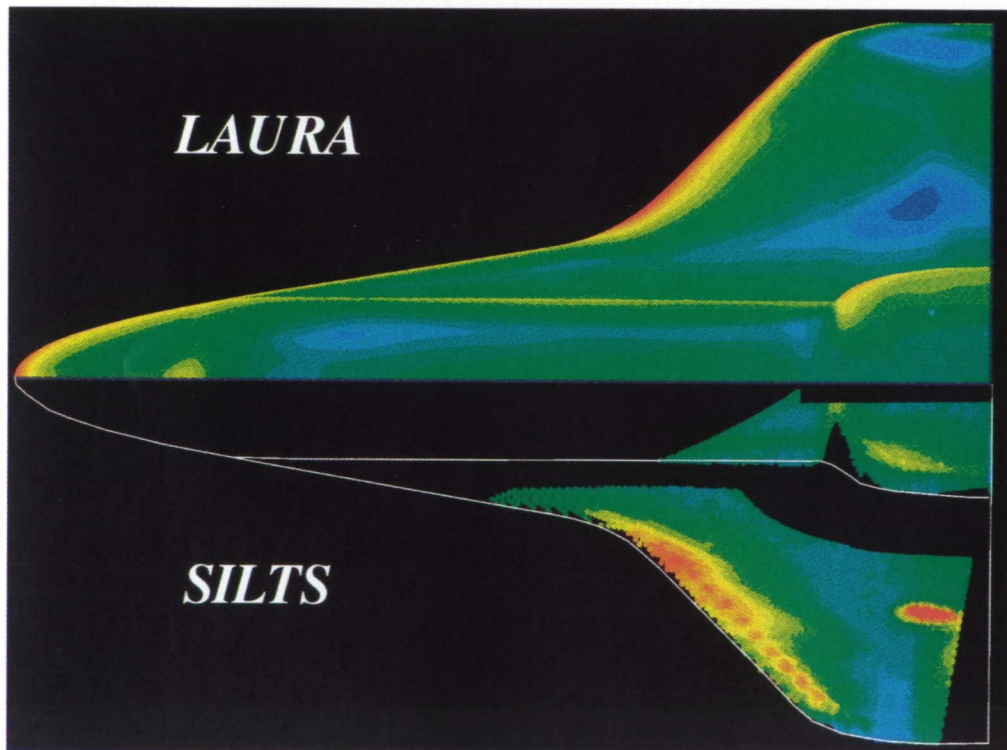

Comparison of the computed leeside surface temperature (top half) and the measured surface temperatures (bottom half) from STS-32 at  $M_\infty = 24$  and 40 degrees angle of attack.

# Tropospheric Aerosols and Clouds

Douglas L. Westphal, Principal Investigator  
Co-Investigator: Owen B. Toon  
NASA Ames Research Center

## Research Objective

To create a general numerical model capable of simulating complicated interactions between dynamics, aerosol microphysics, clouds, and radiative transfer in the Earth's atmosphere.

## Approach

A model of atmospheric dynamics, aerosol and cloud microphysics, and radiative heat transfer is evaluated by simulating actual atmospheric phenomena and comparing the results with observations made during NASA-sponsored field programs. Sensitivity tests are done to study the importance of unmeasured processes or poorly known quantities.

## Accomplishment Description

The model was applied to 10 different cases during the First International Satellite, Cloud, and Climatology Regional Field Experiment in Kansas. The installation of a local ethernet with Internet connectivity during the experiment allowed near-real-time simulations of the atmosphere and comparisons with the field measurements. Several different cloud parameterizations were tested. A typical one-day simulation on a grid of  $77 \times 58 \times 25$  required 3,600 Cray Y-MP seconds and 10 megawords of memory.

## Significance

The model is used as a test bed for the different cloud and radiation parameterizations. The simulations are compared with instantaneous atmospheric measurements and the parameterization weaknesses are identified. The combined model is used to study the large-scale aspects of formation, maintenance, and dissipation of tropospheric clouds, to interpret aircraft data collected during field experiments, and to study the Earth's climate.

## Future Plans

Comparisons between the model simulations and the field data will be made, the cloud and radiation parameterizations will be improved, and studies with a nested version of the model with 60 km resolution for the coarse grid and 20 km in the nested grid will be initiated. The finer resolution of the model allows simulations on scales more consistent with the field and satellite observations and should yield a better representation of meso-scale (20–200 km) dynamics.

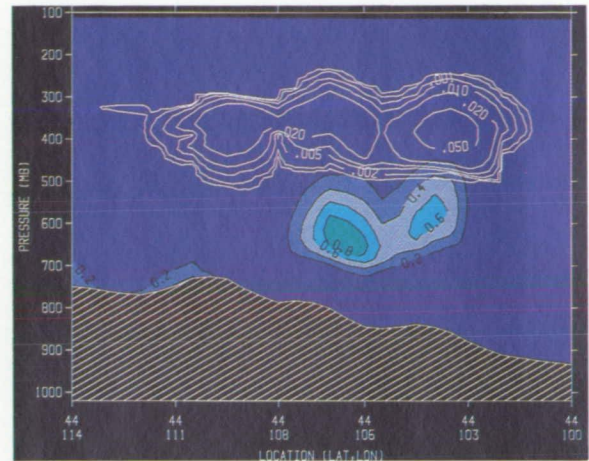

(a)

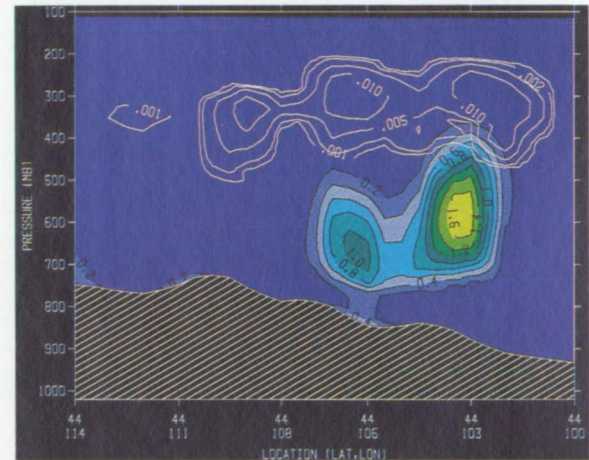

(b)

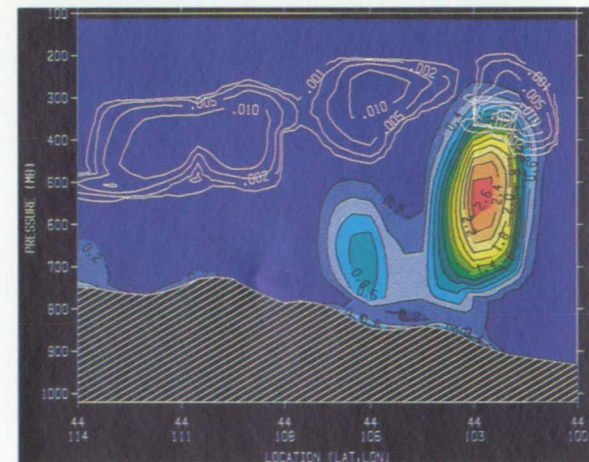

(c)

West-to-east cross section of simulated cloud ice (white contours) and snow (shaded contours) at (a) four, (b) five, and (c) six hours of model simulation showing the development and eastward propagation of bands of precipitation.

# Supersonic Chemically Reacting Turbulent Flow

J. A. White, Principal Investigator

Co-Investigators: J. P. Drummond, J. J. Korte, and M. H. Carpenter  
NASA Langley Research Center

## Research Objective

To investigate the phenomenon that controls the generation of vortical structures in supersonic flow and to utilize that knowledge in optimizing the design of scramjet fuel injection configurations through mixing enhancement.

## Approach

A three-dimensional parabolized Navier-Stokes (PNS) code that employed a near-third-order total-variation-diminishing (TVD) scheme was used to analyze flow around a candidate National Aero-Space Plane scramjet fuel-injection configuration to provide an improved understanding of the loss-generation mechanisms governing the vortex-generation phenomenon employed to enhance mixing. The PNS algorithm is based on a flux-difference-splitting approach and was used because of its superior robustness and shock capturing capability.

## Accomplishment Description

Previously, a computer code was developed that solved the parabolized equations governing a multicomponent mixing flow utilizing a TVD upwind scheme. The code was validated against experiments involving reacting and non-reacting flows and then applied to analyze three-dimensional flows in scramjet combustors. Recent experimental research has been directed toward improving the efficiency of scramjet combustors through mixing-enhancement configurations. A configuration under consideration is the swept-ramp fuel injector. It has been the subject of several experimental and numerical investigations. The vorticity induced by the swept-ramp configuration can significantly improve mixing and combustion in supersonic flows. The desire to increase mixing through the generation of streamwise vortices must be tempered by the inherent increase in total pressure loss. Recent work has been concerned with improving the understanding of the phenomenon governing vorticity and loss generation of the swept-ramp configuration. The accompanying figure shows the density contours at a symmetry and outflow plane with streak-line paths superimposed for a typical configuration. The streak-line paths delineate the vortex core and trace the origin of the core.

## Significance

The numerical simulation provides an improved understanding of the complex interactions controlling mixing and loss generation in three-dimensional supersonic flows. This knowledge can be used to improve the design of fuel-injection configurations for scramjet combustors, thereby improving the overall combustor efficiency and contributing to vehicle closure.

## Future Plans

The injector-induced vortical structure will be coupled with the primary fuel-injection source interacting with a planar shock in order to investigate the interaction of the multiple vortical structures.

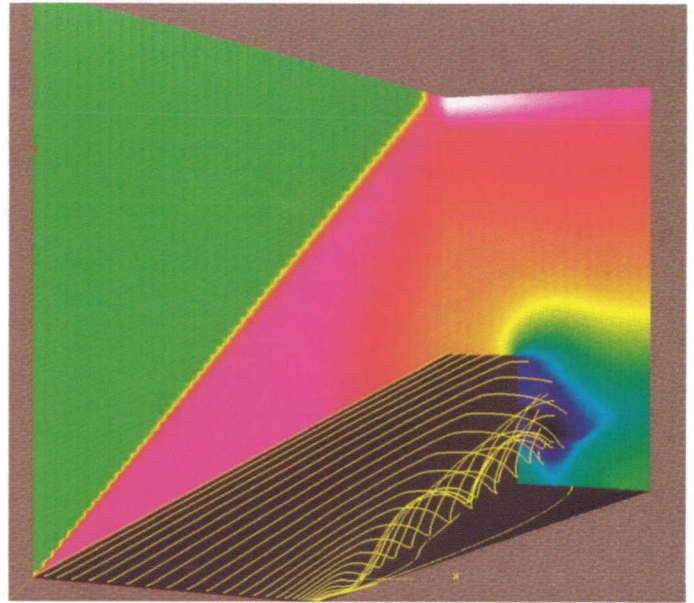

*Vortex structure and density contours of a scramjet swept-ramp fuel injector; red = high density, black = low density.*

# Shock Interactions in Hypersonic Rarefied Flows

Richard G. Wilmoth, Principal Investigator  
Co-Investigators: V. K. Dogra and J. N. Moss  
NASA Langley Research Center/ViGYAN, Inc.

## Research Objective

To provide fundamental information on shock–shock, shock–boundary-layer, and shock–shear-layer interactions in hypersonic rarefied flows.

## Approach

The direct simulation Monte Carlo (DSMC) method was used to model the shock layer of a sphere (1.6 meters in diameter) during Earth entry and the shear layers created by shock–shock interactions in hypersonic inlet cowl-lip flows.

## Accomplishment Description

Calculations of the molecular velocity and energy distributions behind the bow shock of the sphere were completed for entry conditions at altitudes of 130–90 km. Initial calculations of mixing in hypersonic, rarefied shear layers were performed at conditions corresponding to those behind an oblique shock impinging on a bow shock. A block parallel version of the two-dimensional DSMC code was developed and allowed multitasking on the Cray-2 and Cray Y-MP through the use of Oak Ridge National Laboratory's parallel virtual machine message-passing software.

## Significance

The sphere results demonstrate the non-Maxwellian nature of the velocity distributions in transitional flow. The shear-flow simulations showed the mixing to be self-similar, but with considerable density and temperature variations introduced into the initially constant density shear layer. The block parallel version of the DSMC code will provide the capability to solve larger problems by taking advantage of the multiprocessing capabilities of the Crays.

## Future Plans

Further calculations of shear–shear and shock–shear interactions at conditions corresponding to National Aero-Space Plane flight conditions are planned. Development of the parallel code will continue and applications to unsteady flows are planned.

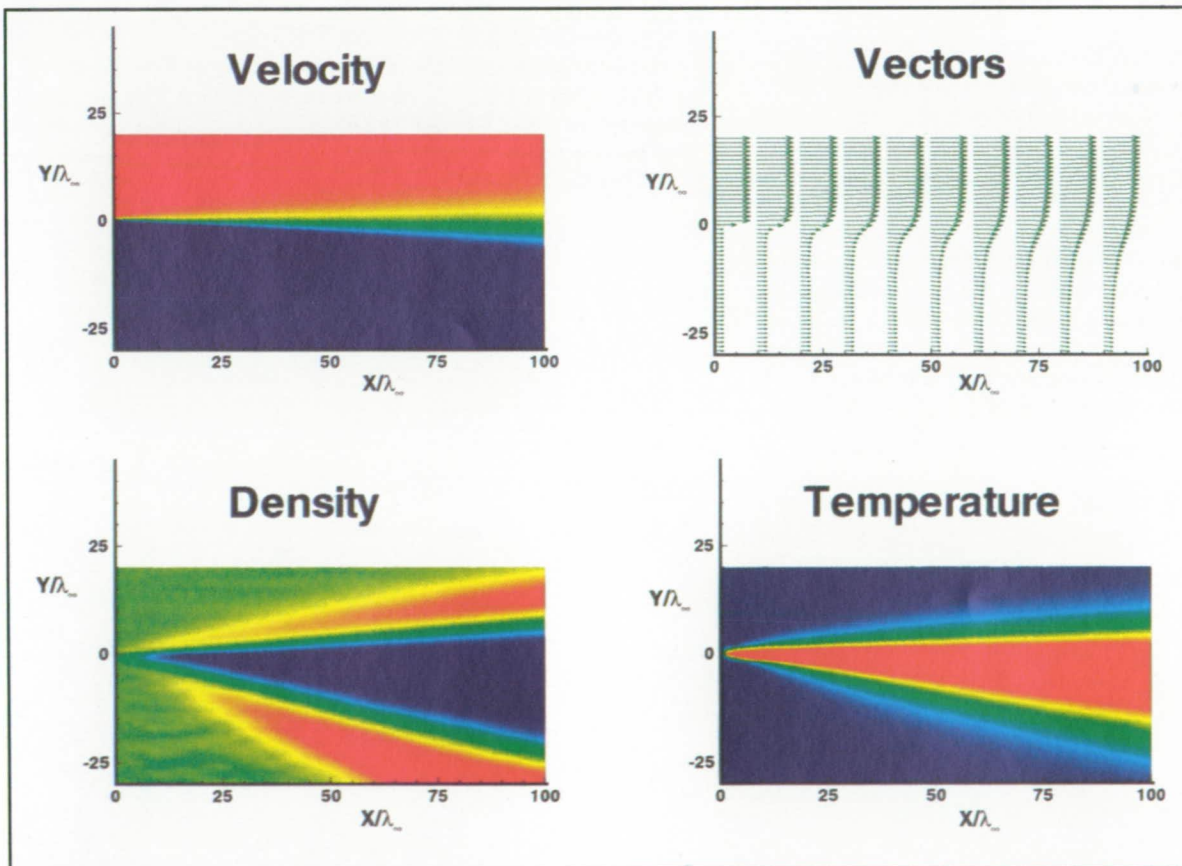

Direct simulation Monte Carlo model of hypersonic shear flow.

# Supersonic Laminar Flow Control Concept

Chung-Jin Woan, Principal Investigator

Co-Investigators: Michael W. George and Philip B. Gingrich  
Rockwell International, North American Aircraft Division

## Research Objective

To develop and demonstrate a computational fluid dynamics (CFD) ability in predicting and modeling transition due to attachment line, cross flow, and Tollmien–Schlichting instabilities in the supersonic flow regime.

## Approach

A Navier–Stokes solver is used in conjunction with a three-dimensional compressible stability analysis to predict the boundary-layer transition location. The methodology has been applied to an F-16xL aircraft with a wing suction glove.

## Accomplishment Description

A coarse multiblock Euler grid with approximately 550,000 grid points was constructed from the existing Navier–Stokes grid. An Euler flow was calculated at Mach 1.6 and 2 degrees angle of attack using the USARG3 code and the NASA Langley CFL3D code. Excellent agreement in flow properties was noted for the two methods. The accompanying figure compares the two solutions in terms of pressure contours at the plane of symmetry. The computation used 85 Cray-2 hours and 35 megawords of memory for an average Navier–Stokes job run using approximately 1 million grid points, or 6 Cray-2 hours for an average Euler job run using approximately 550,000 grid points.

## Significance

A numerical ability to predict transition and the extension of laminar flow control to supersonic and hypersonic regimes will benefit several national programs, including the High Speed Civil Transport and the National Aero-Space Plane.

## Future Plans

Continued effort will be directed at validating the CFD methodology and the design approach through the revision of the numerical configuration model based on the measured F-16xL supersonic laminar-flow-control geometry and the expansion of computations aligned with the ongoing flight-test program.

## Publication

George, M. W. "Status of the F-16xL Supersonic Laminar Flow Control: Numerical Design Validation." First Annual High-Speed Research Workshop, Williamsburg, VA, May 1991.

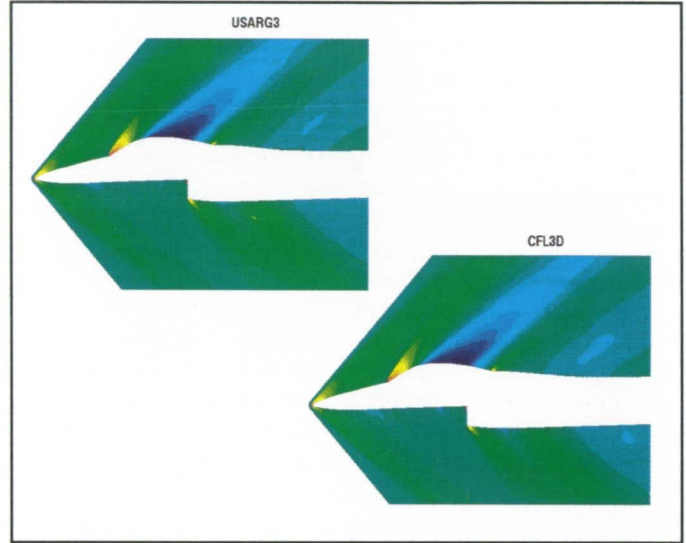

*Calculated pressures in the plane of symmetry of a modified F-16xL at Mach 1.6 and 2 degrees angle of attack. The pressure ranges from 0.5–2.5 of free-stream pressure with blue representing the low value and red the high value.*

# Nozzle Screech Phenomena

Chung-Jin Woan, Principal Investigator  
Co-Investigator: Michael W. George  
Rockwell International, North American Aircraft Division

## Research Objective

To develop and validate a computational fluid dynamics capability in predicting and modeling nozzle acoustic noise generated by high-performance aircraft and to generate a better understanding of the physical phenomena of jet aeroacoustics.

## Approach

A Navier–Stokes code based on a high-order accuracy upwinding total-variation-diminishing scheme is used to calculate the time-accurate jet-flow evolution and the predictions are correlated with the existing data base.

## Accomplishment Description

A grid for a NASA experimental research convergent–divergent nozzle has been developed and the internal flow has been calculated and obtained for a laminar flow and two turbulent flows with zero- and two-equation turbulence models at  $P_{exit}/P_{ambient} = 1.55$ . Three external grids (coarse, fine, and very fine) were generated and coupled with the internal grid for the toroidal screech simulation. The solution, calculated as laminar

flow on the coarse grid, converged and became steady. Turbulent-flow calculation for the same jet flow on the very fine grid has been performed near the jet exit. The upper part of the accompanying figure shows the early evolution of the calculated jet near the nozzle exit in terms of the density contours. The lower part of the figure shows the Mach contours of the calculated laminar flow on the coarse grid and compares the calculated and measured static pressures along the axis of symmetry.

## Significance

A numerical ability to predict jet aeroacoustics will provide a path to a better understanding of the jet aeroacoustic phenomena and will be applied to existing and future high-performance aircraft and space-transportation vehicles.

## Future Plans

Continued effort will be directed at completion of toroidal and helical screech simulations and investigation of turbulence model effects on the accuracy of jet-flow predictions.

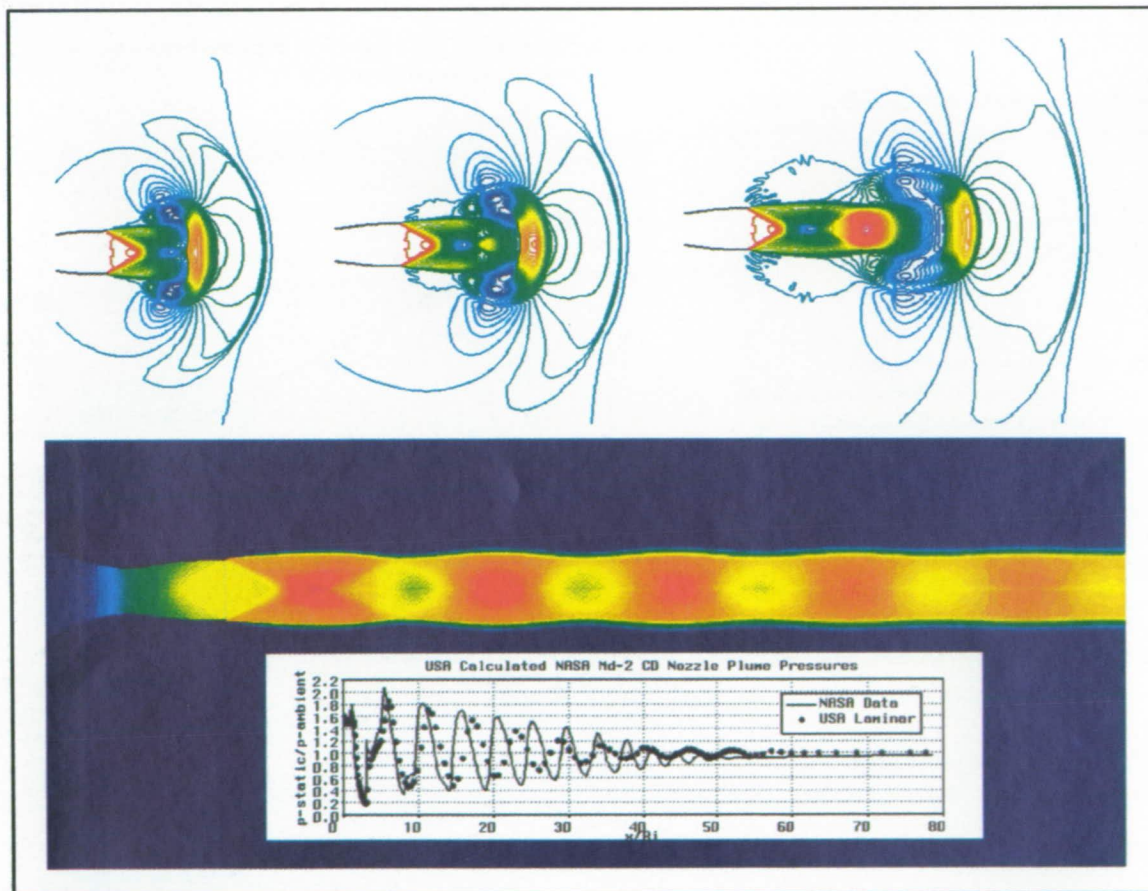

Calculated jet flow into a static ambient air; the upper part of the figure shows the early evolution of the jet near the nozzle exit and the lower part of the figure shows the Mach number contours with blue representing the low value and red the high value.

# Advanced Computational Materials Research

J. P. Wolfe, Principal Investigator

Co-Investigators: R. Averback, J. Kogut, and P. Wolynes

University of Illinois, Urbana/Champaign

## Research Objective

To develop and apply new algorithmic approaches to problems in the science of materials, particularly those related to quantum systems and statistical problems.

## Approach

A variety of computational approaches are used.

## Accomplishment Description

Molecular dynamics computer simulations of energetic clusters with metal surfaces were conducted. The project examined the impact of ion cluster beams with solid surfaces. The accompanying figure shows a resulting mechanism map for cluster–solid interactions, where the size, energy, and cohesive properties were variables. It appears that it is best to have soft clusters impact hard substrates. We simulated the Ising model on a two-dimensional dynamically triangulated lattice and determined that it has a second-order phase transition. The critical indices were calculated by finite scaling methods (see the accompanying figure), showing that the liquid lattice dresses the critical indices in accord with expectations. The simulation algorithm used a dual-lattice formulation that was amenable to vectorization.

## Significance

The simulations have analytical and predictive value for current problems in materials.

## Future Plans

The preliminary studies of dipolar excitons on a disordered materials conducted in this study will be compared with analytic theories.

## Publications

1. Hsieh, H. and Averback, R. S. "Molecular-Dynamics Simulations of the Impact of Energetic Cu Clusters on Cu and Ni Substrates." *Materials Research Society Symposium Proceedings* 206 (1991): 375–380.
2. Hsieh, H.; Averback, R. S.; Sellers, H.; and Flynn, C. P. "Molecular-Dynamics Simulations of Collisions Between Energetic Clusters of Atoms and Metal Substrates." *Phys. Rev. Bulletin* 45, no. 8 (1992): 4417–4430.
3. Catterall, S. M.; Kogut, J. B.; and Renken, R. L. "Scaling Behavior of the Ising Model Coupled to Two-Dimensional Quantum Gravity." To be published in *Phys. Rev. Bulletin*.

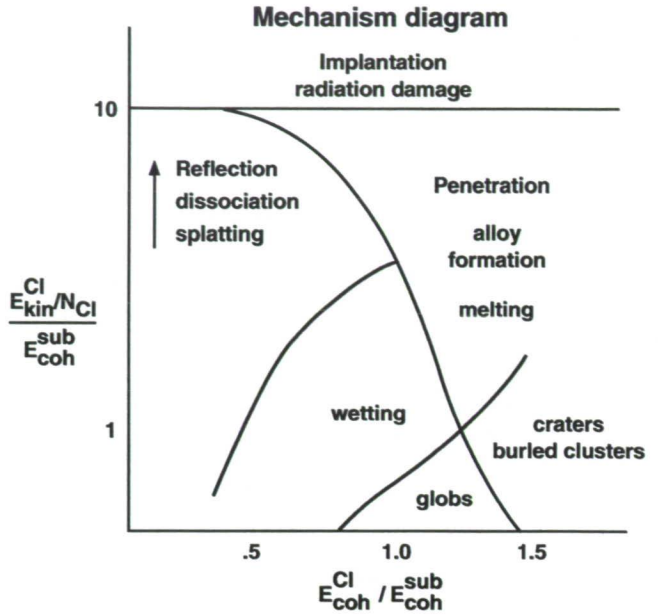

Mechanism diagram of the interaction between energetic clusters of atoms and metal substrates.

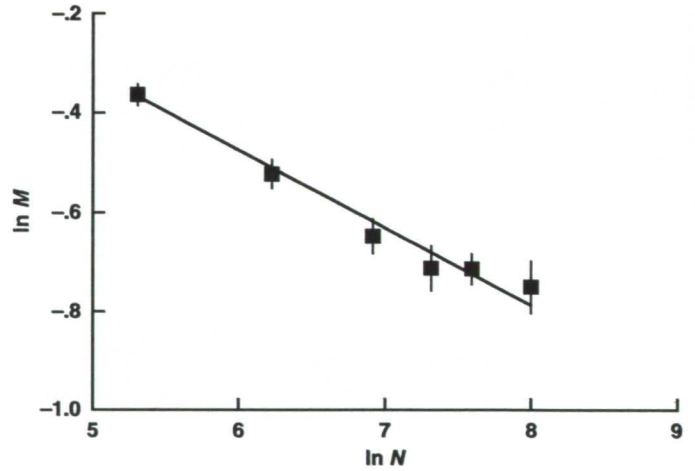

Finite-size scaling of the magnetization at the critical coupling on  $N^2$  lattices.

# Computational Electromagnetics

Alex C. Woo, Principal Investigator  
Co-Investigators: Michael J. Schuh and Michael P. Simon  
NASA Ames Research Center

## Research Objective

To develop the ability to predict the radar cross section (RCS) of simple jet-engine inlet models.

## Approach

RCS3D, a finite-volume time-domain program, was used to integrate Maxwell's equations through a variety of structured grids. Computations were performed with the scattered field, where the total field equaled the scattered field plus the incident field, and the incident field is obtained from an analytical expression. The root mean square (rms) difference between the computed signature and experimental data was used as an estimate of the calculation error.

## Accomplishment Description

Factors influencing the accuracy of the predicted RCS signature were investigated, including grid density, the number of computational zones, skewness of the grid cells, and harmonic versus Gaussian pulse illumination. The impact on required memory, CPU time, rate of convergence, and overall accuracy were assessed. Calculations were usually run over an azimuthal range of 0–90 degrees, where 0 degrees is looking directly into the mouth of the inlet. The measure of error in the computed RCS is the rms difference over the range from 0–45 degrees. Although the range from 45–90 degrees is not used in the error criterion, it is of interest since it was the disagreement with experiment within this range that prompted the use of a second-order boundary condition at conducting surfaces. For an inlet with wavelength dimensions of  $1.25 \times 1.25 \times 1.875$ , the grid that has yielded the best result to date has seven zones that fill and envelop the inlet with an outer-zone width of one wavelength and nonuniform spacing inside the inlet. The scattered electric field for this computation and the comparison of predicted and measured RCS signatures are shown in the accompanying figures. The preceding result refers to calculations using harmonic excitation. Thus far, the pulse method has not yielded more economical results for a particular frequency than harmonic excitations, but recent results indicate that the pulse method may be advantageous for wide-band calculations.

## Significance

A first-order boundary condition at conducting surfaces is inadequate; a second order condition must be used to obtain acceptable results. For horizontal polarization, a rms difference between predicted and measured RCS of less than 1 dB is achievable for the inlet using 5.2 megawords of memory and 1.4 Cray Y-MP hours.

## Future Plans

Work is directed toward the use of Gaussian pulse-incident fields, computations with an inlet embedded in an infinite ground plane, and the RCS of inlets with cylindrical and more complex geometries.



Scattered electric field of a square-aperture inlet for 30 degrees angle of incidence.

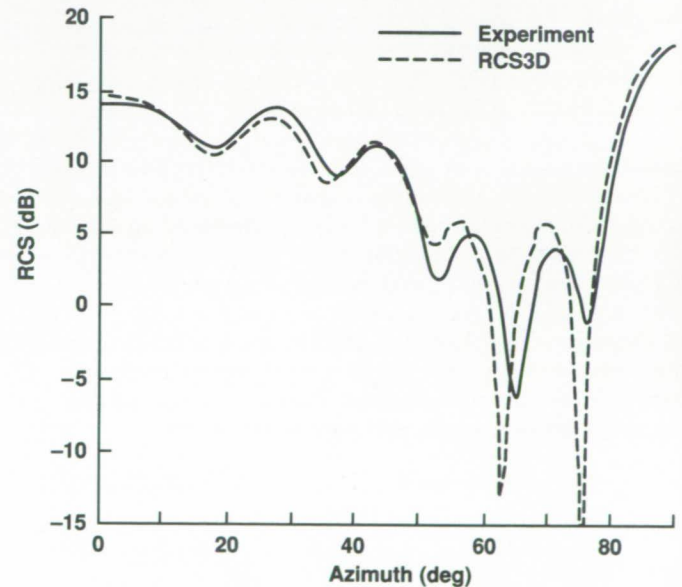

Comparison of computed and experimental radar cross sections.

# Numerical Simulation of the PAMPA Jet Trainer

Perry A. Wooden, Principal Investigator  
Co-Investigator: Ronald D. Lowe  
LTV, Aircraft Division

## Research Objective

To investigate three-dimensional Euler and Navier–Stokes equations on an aircraft at high angle of attack and to highlight each application toward understanding the simulation and identifying areas of improvement to obtain detailed flow-field information of an airplane's aerodynamics.

## Approach

The PAMPA jet trainer was simulated at a high angle of attack and transonic Mach number using the PARC3D code. The multiblock grid was generated using the GRIDGEN codes. Contiguous block interfacing was maintained to eliminate linear interpolation and PLOT3D was used to display the result.

## Accomplishment Description

A numerical experiment was performed on the PAMPA jet trainer at a free-stream Mach number of 0.700 and 20 degrees angle of attack. A multiblock grid containing 70 blocks was generated using the GRIDGEN procedure. Only the wing and fuselage were modeled with the inlet faired to simulate the wind tunnel model. The total number of grid points for the Euler solution was 850,000 with the largest block containing 58,000 points. The simulation required 2,500 iterations at a Courant number of 4 for each block to converge six orders of magnitude. The computations required 20 Cray-2 hours and 4 megawords of memory. Results showed the computed lift coefficient differed by 7% and the pitching-moment coefficient was within 15% of the wind tunnel values.

## Significance

High-angle-of-attack simulation capability of full configuration computational fluid dynamics (CFD) has increased significantly in recent years. As grid generation efficiency has increased, computer memory and speed increases have allowed CFD to be used as an effective tool in aircraft analysis. The influence of full-configuration PAMPA analysis provides the split in load distributions between wing and fuselage components for structural integrity over isolated component analysis. This has reduced risk, wind tunnel test time, and flight test time.

## Future Plans

A Navier–Stokes solution for the PAMPA jet trainer will be computed to improve prediction of the load distribution at high angle of attack. Target areas include increased code efficiency, reduced number of blocks to increase input/output performance, and unstructured grid solvers.

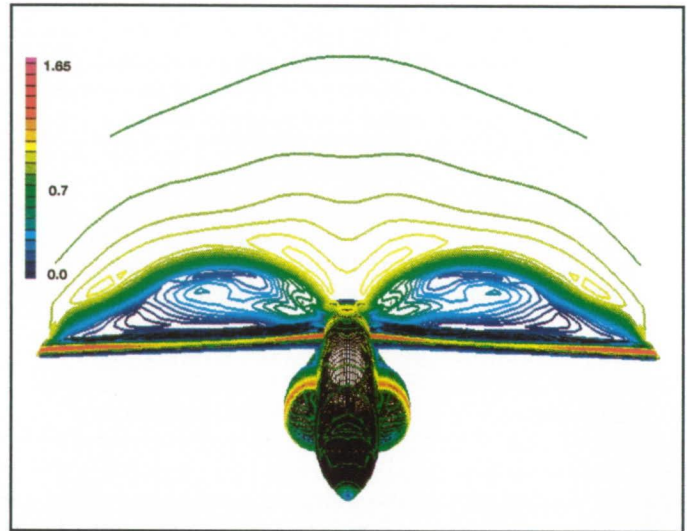

*Mach number color contours from a PARC3D Euler solution at Mach 0.700 and 20 degrees angle of attack.*

# Numerical Simulation of Submarine Propulsion

Cheng-I Yang, Principal Investigator  
David Taylor Research Center

## Research Objective

To simulate the high Reynolds-number flow over a sail-hull configuration. The flow pattern information will then be used for propulsor design. Flow phenomena of particular interest are the tip and horseshoe vortices originated from the sail top and the sail-hull juncture regions. Model tests are concurrently conducted at the towing tank at David Taylor Model Basin. Experiment data will be used for validation.

## Approach

Viscous flow over a sail-hull combination is numerically simulated. Computations are performed with a modified FMC1 code originally developed at NASA Langley. The method is based on an implicit high-resolution scheme for the three-dimensional incompressible Navier-Stokes equations. The inviscid flux is discretized with total-variation-diminishing-like flux-differencing splitting and the viscous flux is discretized with central differencing. The computational grid is generated with a transfinite interpolation technique.

## Accomplishment Description

In this simulation, the Reynolds number is 15 million based on the hull length. The vehicle is at a straight flight condition. A Baldwin-Lomax turbulence model is modified to account for the larger boundary interaction near the sail-hull juncture region. Typical flow patterns are shown in the accompanying figure. The flow patterns on the starboard and the port side are symmetrical, so only those on the starboard side are shown. The development of the hull boundary layer, the tip, and the horseshoe vortices are shown. Similar patterns were found in the towing-tank model test. The computational domain is composed of two blocks with an overlapped region to facilitate data communication between the blocks. A total of 400,000 grid points are used. Computation takes 5 megawords of memory and 2 Cray Y-MP hours.

## Significance

The sail and other appendages may alter the flow pattern considerably and can produce adverse effects on propulsor performance. An accurate prediction of the inflow pattern enables the designer to create a propulsor which will meet all vehicle operating requirements.

## Future Plans

The present method will be used to study the viscous flow around a compound propulsor and will be integrated in the propulsor design cycle. The method will be used to study the detailed flow pattern on a propeller-blade surface and tip vortex.

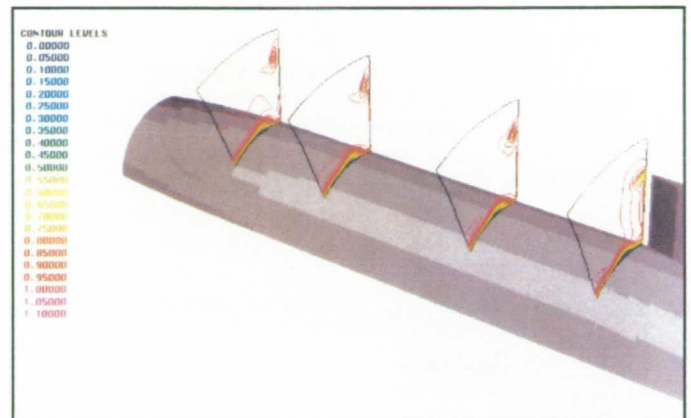

*Axial velocity contours.*

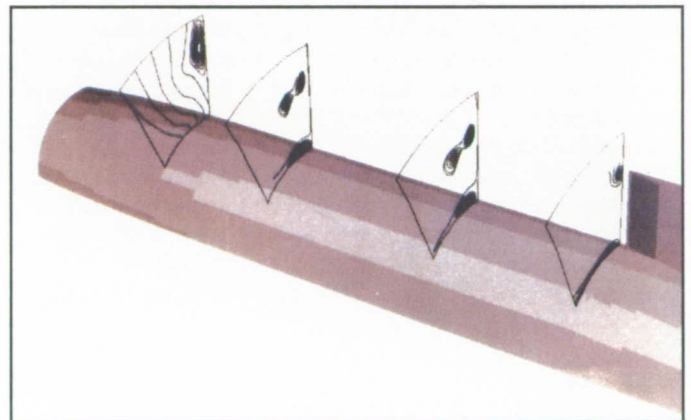

*Cross-flow plane particle traces.*

# Steady and Unsteady Flows at High Angle of Attack

David T. Yeh, Principal Investigator

Co-Investigator: Hiroshi Ide

Rockwell International, North American Aircraft Division

## Research Objective

To extend and validate a computational capability to assist in the design of advanced technology aircraft that are required to operate in a high-angle-of-attack flow environment.

## Approach

The unified solution algorithms (USA) code is used for high-angle-of-attack flow simulations. The USA code solves the three-dimensional Reynolds-averaged Navier–Stokes equations through an upwind flux-difference finite-volume approach. A high resolution total-variation-diminishing scheme is incorporated to achieve higher order spatial accuracy while maintaining numerical stability. The X-31 enhanced fighter maneuverability demonstrator aircraft is the configuration used in the study and was chosen because of its inherently designed high-angle-of-attack characteristics and capabilities, the existence of a wind tunnel data base, and the ongoing flight-test program.

## Accomplishment Description

A blocked-grid approach was exploited to model the X-31 flow field. It applied both aligned and non-aligned blocks to capture the complexity of the geometry and associated flow physics. To identify the flow characteristics of the X-31 at high angle of attack, baseline computations were carried out at 15 and 30 degrees angle of attack corresponding to pre- and post-stall flow regimes, respectively. The baseline calculations were made for all control surfaces at zero deflection. Converged turbulent-flow solutions were obtained under the free-stream conditions of Mach 0.3 and  $Re_\infty \cong 1 \times 10^6/\text{foot}$ . Numerical results were also obtained at 30 degrees angle of attack with the canard deflected under the same free-stream conditions to illustrate the effects of the movable canard on aerodynamic control in the post-stall regime. Numerical results compare favorably with wind tunnel measurements and flight-test data. A typical computation of the complete X-31 aircraft requires 25 megawords of memory and 40 Cray Y-MP hours.

## Significance

The numerical study parallels the ongoing X-31 flight-test program and establishes and extends computational fluid dynamics capabilities for analysis of high-angle-of-attack flow phenomena. This study will have significant impact on current and future military aircraft design.

## Future Plans

We will expand the study to include structural interface and thrust-vectoring paddles.

## Publication

Yeh, D. T.; George, M. W.; Clever, W. C.; Tam, C. K.; and Woan, C. J. "Numerical Study of the X-31 High-Angle-of-Attack Flow Characteristics." AIAA Paper 91-1630, presented at the AIAA 22nd Fluid Dynamics, Plasma Dynamics, and Lasers Conference, Honolulu, HI, June 1991.

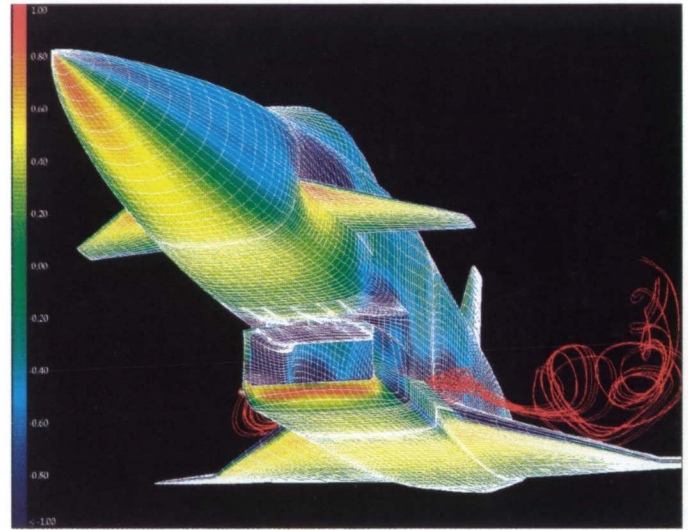

Surface pressure distribution on an X-31 aircraft accompanied by a surface grid and some particle traces emanating from the wing-root leading-edge strake at 30 degrees angle of attack, Mach 0.3, and  $Re_\infty \cong 1 \times 10^6/\text{foot}$ .

# Volcanic Aerosol Clouds in the Stratosphere

Richard E. Young, Principal Investigator

Co-Investigators: Howard Houben and Owen B. Toon

NASA Ames Research Center/Space Physics Research Institute

## Research Objective

To numerically simulate the behavior of the El Chichon and Mt. Pinatubo volcanic aerosol clouds in the stratosphere in order to better understand stratospheric transport and aerosol microphysical processes.

## Approach

A three-dimensional spectral primitive-equation model is used to compute wind and temperature fields in the stratosphere. This model is coupled with a three-dimensional aerosol transport and microphysical model which computes the dispersion of the volcanic aerosol cloud using the computed winds from the circulation model and accounting for such processes as sedimentation and coagulation of the aerosol particles.

## Accomplishment Description

Passive tracer simulations for both the El Chichon and Mt. Pinatubo volcanic aerosol clouds have been conducted for the six months following each eruption. Each simulation required about 12 Cray Y-MP hours and 16 megawords of memory. The results have been compared to the extensive satellite, airborne, and ground-based data sets which exist for each aerosol cloud. Most of the aerosol mass for the eruptions resided in the stratosphere above 20 km altitude. The El Chichon aerosol cloud stayed between the equator and 30°N for six months, while the Mt. Pinatubo cloud spread rapidly southward, reaching 20°S within weeks after the eruption. The model simulations reproduce these observed characteristics. The accompanying figure shows the Mt. Pinatubo volcanic gas and aerosol cloud after it had circumnavigated the globe one time. Initially, the cloud was a column between 20–25 km over the Philippine Islands, but it spread due to wind shear.

## Significance

Major NASA programs study the climatology of the stratosphere. Unique opportunities to better understand stratospheric transport and aerosol microphysical processes occurred when the El Chichon volcano erupted in April 1982 and Mt. Pinatubo erupted in June 1991. By simulating the behavior of the volcanic clouds we can assess and improve theoretical understanding of transport and aerosol processes in the stratosphere.

## Future Plans

Multi-year simulations of the undisturbed stratosphere will be carried out. The results will be used to conduct passive-tracer simulations of the El Chichon and Mt. Pinatubo volcanic clouds. Once the passive-tracer computations are complete, fully interactive tracer simulations will be done.

## Publication

Young, R. E.; Houben, H.; and Toon, O. B. "Simulation of the Dispersion of the El Chichon and Mt. Pinatubo Stratospheric Aerosol Clouds During the First Year after the Eruptions." AGU Chapman Conference on Volcanoes, Climate, and Global Change, Hilo, HI, March 1992.

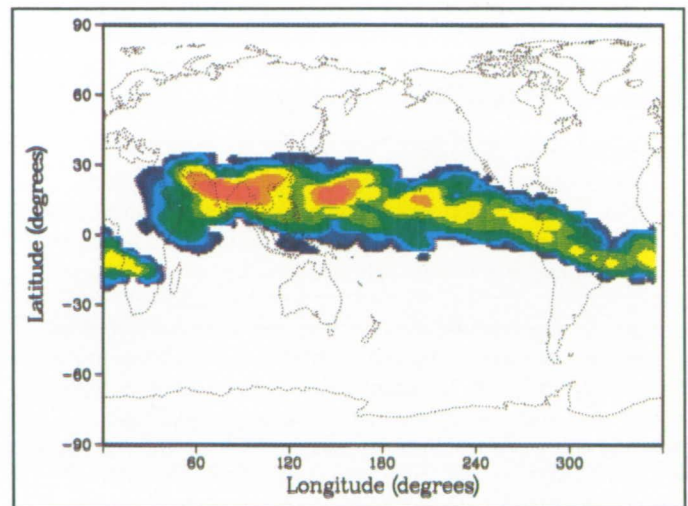

*The Mt. Pinatubo volcanic gas and aerosol cloud after it had circumnavigated the globe one time.*

# Single Expansion Ramp Nozzle with External Burning

Shaye Yungster, Principal Investigator  
ICOMP/NASA Lewis Research Center

## Research Objective

To develop computational fluid dynamics (CFD) prediction techniques to support external burning and nozzle performance experiments aimed at reducing the transonic drag of National Aero-Space Plane (NASP) vehicles.

## Approach

The Reynolds-averaged Navier–Stokes equations with finite-rate chemistry are solved using two- and three-dimensional multiblock fully implicit codes based on the LU-SSOR factorization scheme. The spatial discretization is based on a second order total-variation-diminishing scheme for the two-dimensional code, and central differences with second- and fourth-order artificial damping for the three-dimensional code. Several finite-rate chemistry models for hydrogen–oxygen combustion are being used, ranging from a one-step irreversible chemical reaction to a nine species 18-step reaction mechanism. The Baldwin–Lomax algebraic turbulence model is used.

## Accomplishment Description

The effects of external combustion on NASP-like nozzles at transonic speeds were numerically investigated. A computational model for the external fuel injection and combustion processes was developed, and results were obtained for complete nozzle configurations with hot and cold exhaust flow, and with or without external burning. A typical two-dimensional turbulent calculation with a one-step combustion model is shown in the accompanying figure. The combustion occurs in a layer between the external stream and the internal nozzle plume. Proper handling of the downstream boundary condition was important due to the large subsonic flow region created by the external burning process. A multiblock grid containing a total of 25,000 mesh points was used requiring about 5 megawords of memory and 4 Cray-2 hours. At transonic speeds and without external burning, three-dimensional effects become important due to nozzle over expansion. Three-dimensional calculations of the nozzle and external flow (without external burning) have been performed utilizing four blocks, each having  $140 \times 61 \times 10$  grid points. These computations require about 20 megawords of memory and 12 Cray-2 hours.

## Significance

NASP-like nozzles are highly over-expanded at transonic speeds and this results in large drag increases. One possible way to eliminate this drag is to increase the pressure along the afterbody by external combustion. Numerical simulations can provide details of the flow field, identify wind tunnel interference effects, determine scaling effects, and analyze advanced designs.

## Future Plans

The present model will be enhanced by including complete reaction mechanisms and by detailed modeling of the external fuel-injection process. Simulations are planned for large-scale flame-holding and ignition experiments and hot and cold nozzle tests of current and advanced NASP configurations.

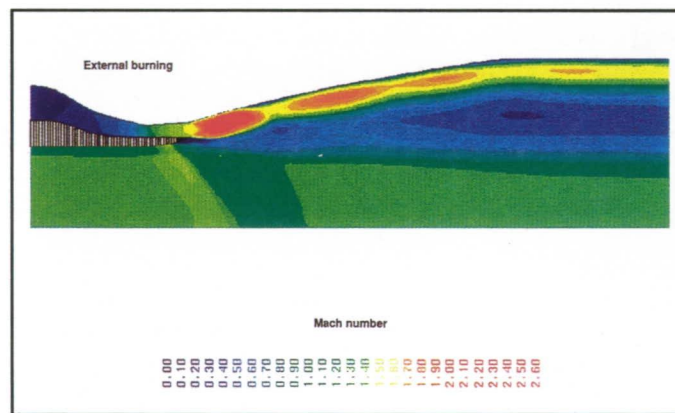
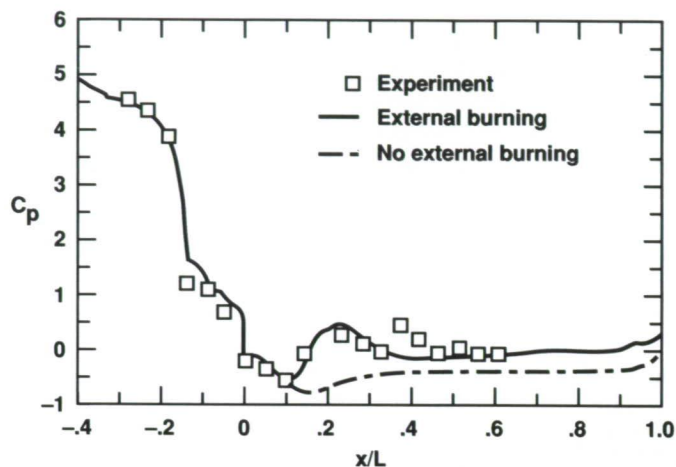

Mach number contours and upper surface pressure distribution for a hot exhaust nozzle with external burning;  $M_\infty = 1.2$ ,  $NPR = 6$ , and  $F/A = 0.021$ .

# Transition Modeling

T. A. Zang, Principal Investigator

Co-Investigators: S. Dinavahi, U. Piomelli, R. Garg, and K. Ball

NASA Langley Research Center/University of Maryland/University of Texas

## Research Objective

To develop effective models for the process by which flows transition from smooth laminar states to chaotic turbulent states.

## Approach

Perform direct numerical simulations (DNS) and large-eddy simulations (LES) of simple, low-speed flows under controlled conditions in the transitional and turbulent regimes. These are used for investigation of basic transition physics as well as for assessing the utility of various LES, Reynolds-averaged, and dynamical system approaches.

## Accomplishment Description

The DNS of fundamental channel flow transition at Reynolds number 8,000, begun in 1989, was continued into the fully turbulent regime. This data base was analyzed to furnish the Reynolds-stress budgets for the fully turbulent regime, but more interestingly, for the transitional regime. In addition, the proper orthogonal decomposition was performed for the turbulent state. In a separate investigation, DNS was applied to tuned and detuned boundary-layer transition. The latter type of transition is more closely related to natural transition than the former. The results indicated that a small amount of detuning, even if only in the form of background noise, of an otherwise tuned transition problem can have a dramatic effect upon experimental diagnostics of high-shear layers. This is illustrated in the accompanying figure, which displays the mean velocity profiles in the symmetry plane for three transition simulations. The initial conditions for each included the same primary wave, but they differed in the initial three-dimensional component: a tuned subharmonic, a pure detuned mode, and a tuned subharmonic plus a small,

detuned, "environmental," component. A strong inflectional profile (indicative of high-shear layers) appeared only for the first case. Detuning led to a much milder average inflection (closer to experimental measurements), although closer examination revealed the presence of intense local inflections. Typical runs took 50–100 Cray-2 hours and 40 megawords of main memory.

## Significance

The DNS of boundary-layer transition may explain why certain transition experiments have not produced evidence of high-shear layers.

## Future Plans

The later stages of detuned transition will be investigated. LES methodology will be more thoroughly tested and then extended to spatial and compressible transition.

## Publications

1. Zang, T. A. "Aspects of Laminar Breakdown in Boundary-Layer Transition." *ICASE/LaRC Workshop on Transition and Turbulence*, ed. M. Y. Hussaini. New York: Springer, 1992.
2. Dinavahi, S. P. G. and Zang, T. A. "Reynolds Stress Budget in a Transitional Channel Flow." *ICASE/LaRC Workshop on Transition and Turbulence*, ed. M. Y. Hussaini. New York: Springer, 1992.
3. Garg, R. P. and Piomelli, U. "Large-Eddy Simulation of Detuned Transition in Plane Channel Flow." *4th International Symposium on Computational Fluid Dynamics*. Davis, CA, Sept. 1991.

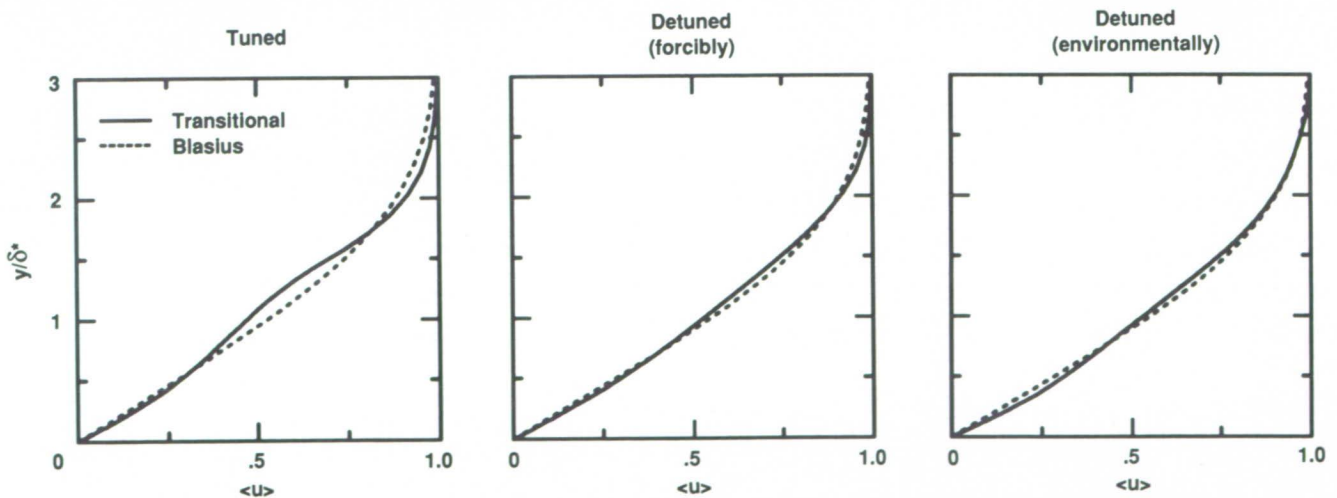

Mean velocity profiles in the wall-normal direction from three related simulations of boundary-layer transition. The wall-normal coordinate is scaled by the local displacement thickness  $\delta^*$ . The laminar (Blasius) profile is included for reference.

# Index by Research Sites

	Page
<b>A.T.M., Inc.</b>	
Jeffrey N. Cuzzi                      Particle-Gas Dynamics in the Protoplanetary Nebula .....	36
	(with NASA Ames Research Center and University of California, Santa Cruz)
<b>Adaptive Research Corporation</b>	
R. R. Chamberlain                      Aerothermal Analysis of Hypersonic Defense Interceptors .....	20
<b>Advanced Projects Research, Inc.</b>	
Joseph W. Humphrey                      Hypersonic Scramjet and Detonation Flows .....	83
	(with University of Arizona and NASA Langley Research Center)
Darrell W. Pepper                      Hypersonic Scramjet Flow .....	151
<b>Amtec Engineering, Inc.</b>	
Scott T. Imlay                      Aero-Assisted Orbital Transfer Vehicle Flow Fields .....	86
<b>Analytical Services and Materials, Inc.</b>	
William B. Compton, III                      Three-Dimensional Afterbody Flow with Jet Exhaust .....	31
	(with NASA Langley Research Center)
Charles R. McClinton                      High Mach-Number Mixing in a Shock Tunnel Environment .....	129
	(with NASA Langley Research Center)
Charles R. McClinton                      National Aero-Space Plane Configuration Trade Studies .....	130
	(with NASA Langley Research Center)
Charles R. McClinton                      Scramjet Inlet Interaction .....	131
	(with NASA Langley Research Center)
Charles R. McClinton                      Scramjet Engine Design Optimization .....	132
	(with NASA Langley Research Center)
S. Paul Pao                      Afterbody Aerodynamics with Canted Pitch-Vectoring Twin Nozzles .....	149
	(with NASA Langley Research Center)
C. D. Pruett                      Laminar Breakdown of High-Speed Boundary-Layer Flow .....	158
	(with NASA Langley Research Center)
R. Clayton Rogers                      Hypervelocity Mixing and Combustion in Pulse Facility Flows .....	165
	(with NASA Langley Research Center and University of Missouri, Rolla)
<b>Aurora Science, Inc.</b>	
C. S. Lin                      Electron-Beam Injections from the Space Shuttle .....	118
	(with Southwest Research Institute)
<b>Bell Helicopter Textron, Inc.</b>	
J. C. Narramore                      Rotorcraft Drag Prediction .....	144

PRECEDING PAGE BLANK NOT FILMED

## Berkeley Research Associates

Stephen H. Brecht	Global-Venus/Solar-Wind Interaction .....	14
-------------------	-------------------------------------------	----

## Boeing Commercial Airplane Group

Philippe R. Spalart	Complex Turbulent Boundary Layers .....	186
---------------------	-----------------------------------------	-----

## Boeing Company, The

H. C. Chen	Euler Analysis of Turboprop and Turbofan Integration .....	24
	(with ViGYAN, Inc. and NASA Langley Research Center)	

## California Polytechnic State University, San Luis Obispo

Karlin R. Roth	Validation of a Short Takeoff and Vertical Landing Model .....	170
	(with NASA Ames Research Center)	

## Carnegie Mellon University

Wei J. Chyu	Airframe and Inlet Aerodynamics .....	29
	(with NASA Ames Research Center and Cornell University)	

Tom I-P. Shih	Wankel Engine Flow Fields .....	179
	(with NASA Lewis Research Center)	

## Case Western Reserve University

Russell G. DeAnna	Transition over a Rough Surface .....	42
	(with U.S. Army Propulsion Directorate, AVSCOM)	

Isaac Greber	Numerical Calculation of a Three-Dimensional Separated Flow .....	63
--------------	-------------------------------------------------------------------	----

## Center for Turbulence Research

Parviz Moin	Shock-Wave/Turbulent-Boundary-Layer Interaction .....	140
	(with Stanford University and NASA Ames Research Center)	

## Cornell University

Wei J. Chyu	Airframe and Inlet Aerodynamics .....	29
	(with NASA Ames Research Center and Carnegie Mellon University)	

## David Taylor Research Center

Chao-Ho Sung	Computational Fluid Dynamics for Naval Applications .....	193
--------------	-----------------------------------------------------------	-----

Cheng-I Yang	Numerical Simulation of Submarine Propulsion .....	220
--------------	----------------------------------------------------	-----

## Douglas Aircraft Company

Lee T. Chen	Advanced Transonic Wing Concepts .....	25
-------------	----------------------------------------	----

Gregory A. Intemann	Wing-Nacelle-Pylon Installations .....	87
	(with McDonnell Aircraft Company)	

Walter O. Valarezo	Multi-Element High-Lift Concepts .....	202
	(with NASA Langley Research Center and ICASE)	

**Eloret Institute**

G. S. Deiwert	Self-Adaptive Grid Code Applied to Complex Three-Dimensional Flows ..... 45 (with NASA Ames Research Center and Sterling Software)	45
Larry L. Erickson	Flow Solver for Euler Equations on Unstructured Tetrahedral Meshes ..... 53 (with NASA Ames Research Center)	53

**General Dynamics, Convair Division**

Jack H. Kennedy	Aeronautical Vehicle Radar Cross Sections ..... 96	96
-----------------	----------------------------------------------------	----

**General Dynamics, Electric Boat Division**

Donald W. Davis	Hydrodynamic Performance Evaluation ..... 40	40
-----------------	----------------------------------------------	----

**General Dynamics, Fort Worth Division**

Steve L. Karman, Jr.	Unstructured Grid-Generation/Flow-Solver Calibration ..... 93	93
Brian R. Smith	Computational Fluid Dynamics Methods for Highly Maneuverable Aircraft ..... 181	181

**General Dynamics, Space Systems Division**

Thanh T. Phan	Rocket-Base Flow-Field Simulations ..... 153	153
---------------	----------------------------------------------	-----

**General Electric Aircraft Engines**

Robert F. Bergholz	Three-Dimensional Exhaust-Nozzle Flow Fields for High-Speed Civil Transport ..... 10	10
Joseph L. Garrett	Integrated Hypersonic-Propulsion Flow Paths ..... 59 (with Pratt & Whitney)	59
Sundares V. Subramanian	Viscous Reacting-Flow Applications to Scramjet Propulsion ..... 191	191

**General Motors Corporation, Allison Gas Turbine Division**

Andrew J. Crook	Endwall and Casing Treatment Flow in a Transonic Fan Rotor ..... 33	33
Edward J. Hall	Unsteady Counterrotation of Ducted Propfans ..... 69	69
Jeff L. Hansen	Incorporation of a Three-Dimensional Multistage Viscous Code into a Compressor Design System ..... 74 (with NASA Lewis Research Center)	74
Kurt F. Weber	Flow Simulation in Fan and Core Compressor Stages ..... 210	210

**General Motors Technical Center**

Budugur Lakshminarayana	Steady and Unsteady Turbomachinery Flow Fields ..... 108 (with Pennsylvania State University)	108
-------------------------	--------------------------------------------------------------------------------------------------	-----

**GEOLAB**

Robert E. Smith	Grid Generation for Aerodynamic Configurations ..... 184 (with NASA Langley Research Center)	184
-----------------	-------------------------------------------------------------------------------------------------	-----



	Page
Christian L. Keppenne	Orographically Forced Oscillations of the Martian Atmosphere ..... 97
<b>Korea Advanced Institute of Science and Technology</b>	
Carolyn R. Kaplan	Unsteady Ethylene Jet-Diffusion Flames ..... 92 (with Naval Research Laboratory)
<b>Lockheed Engineering and Sciences Company</b>	
Lawrence D. Huebner	Generic National Aero-Space Plane Fuselage Configuration Study ..... 82 (with NASA Langley Research Center)
Kenneth M. Jones	Analysis of High-Speed Civil Transport Configurations ..... 88 (with NASA Langley Research Center and ViGYAN, Inc.)
Elizabeth M. Lee	Subsonic/Transonic Flutter Boundaries ..... 112 (with NASA Langley Research Center)
Ajay K. Pandey	Thermo-Viscoplastic Analysis of an Engine-Cowl Leading Edge ..... 148 (with NASA Langley Research Center)
Ramadas K. Prabhu	Hypersonic-Flow Computations using Adaptive Unstructured Meshes ..... 157 (with NASA Langley Research Center)
Rajiv Thareja	Unstructured Multigrid Euler Solver ..... 196 (with Imperial College and University College, Wales)
Gururaja R. Vemaganti	Two-Equation Turbulence-Model Implementation ..... 206
<b>LTV, Aircraft Division</b>	
Perry A. Wooden	Numerical Simulation of the PAMPA Jet Trainer ..... 220
<b>Martin Marietta Astronautics Group</b>	
C. T. Edquist	Aerobraking Studies of Three-Dimensional Nonequilibrium Viscous Flow ..... 49
<b>MCAT Institute</b>	
Thomas A. Edwards	Aerodynamic Optimization of Supersonic Transport Aircraft ..... 50 (with NASA Ames Research Center)
Thomas T. Huang	Submarine-Appendage Design and Turbulence Modeling ..... 81 (with Naval Surface Warfare Center; Jason Associates; and Scientific Research Associates, Inc.)
Scott L. Lawrence	Integrated Hypersonic Vehicle Flow-Field Analysis ..... 110 (with NASA Ames Research Center)
W. R. Van Dalsem	Simulation of the Unsteady Flow about Transonic Cavities ..... 203 (with NASA Ames Research Center)
W. R. Van Dalsem	Powered-Lift Computational Fluid Dynamics Project ..... 204 (with NASA Ames Research Center)

## McDonnell Aircraft Company

Shreekant Agrawal	Numerical Calculation of Vortical Flows .....	3
Alan B. Cain	Simulation and Modeling of Turbulence and Flow Acoustics ..... (with NASA Ames Research Center)	16
Raymond R. Cosner	Analyses of F/A-18E/F Upgrades .....	32
David W. Halt	Transonic Analysis on Unstructured Grids ..... (with McDonnell Douglas Research Laboratories)	72
Gregory A. Intemann	Wing-Nacelle-Pylon Installations..... (with Douglas Aircraft Company)	87
Linda D. Kral	Turbulence Modeling for Three-Dimensional Flow Fields ..... (with McDonnell Douglas Research Laboratories)	103

## McDonnell Douglas Corporation

C. C. Lee	Numerical Investigation of Vehicles Similar to the National Aero-Space Plane .....	111
-----------	------------------------------------------------------------------------------------	-----

## McDonnell Douglas Research Laboratories

Ramesh K. Agarwal	Numerical Solution of Three-Dimensional Maxwell's Equations .....	1
Ramesh K. Agarwal	Helicopter Fuselage, Rotor, and Rotor/Body Interaction Flow-Field Calculations .....	2
William W. Bower	Short Takeoff and Vertical Landing Aircraft Thermal/Acoustic Loads..... (with Nielsen Engineering and Research, Inc.)	12
Jerry E. Deese	Flow about Almost Complete Aircraft and Hypersonic Configurations .....	43
David W. Halt	Transonic Analysis on Unstructured Grids ..... (with McDonnell Aircraft Company)	72
Linda D. Kral	Receptivity, Transition, and Turbulence Phenomena .....	102
Linda D. Kral	Turbulence Modeling for Three-Dimensional Flow Fields ..... (with McDonnell Aircraft Company)	103
David L. Marcum	Flow-Field Calculations using Unstructured Grids .....	126
	(with Mississippi State University)	

## Mississippi State University

David L. Marcum	Flow-Field Calculations using Unstructured Grids .....	126
	(with McDonnell Douglas Research Laboratories)	

## NASA Ames Research Center

Jeffrey R. Barnes	Nonlinear Baroclinic Instability .....	6
	(with Oregon State University)	

	Page
Alan B. Cain	Simulation and Modeling of Turbulence and Flow Acoustics ..... 16 (with McDonnell Aircraft Company)
Frank Caradonna	Prediction of Advanced Rotor Performance ..... 19 (with U.S. Army Aeroflightdynamics Directorate, AVSCOM)
Dean R. Chapman	Boost-Phase Detection Study ..... 21 (with Stanford University)
Denny Chaussee	Transonic and Supersonic Flow Past Aircraft Configurations ..... 22
C. L. Chen	Numerical Analysis of Three-Dimensional Separated Juncture Flows ..... 23 (with Rockwell International Science Center)
Wei J. Chyu	Airframe and Inlet Aerodynamics ..... 29 (with Cornell University and Carnegie Mellon University)
Jeffrey N. Cuzzi	Particle-Gas Dynamics in the Protoplanetary Nebula ..... 36 (with A.T.M., Inc. and University of California, Santa Cruz)
Jerry E. Deese	Flow about Almost Complete Aircraft and Hypersonic Configurations ..... 43 (with McDonnell Douglas Research Laboratories)
G. S. Deiwert	Self-Adaptive Grid Code Applied to Complex Three-Dimensional Flows ..... 45 (with Sterling Software and Eloret Institute)
Thomas A. Edwards	Aerodynamic Optimization of Supersonic Transport Aircraft ..... 50 (with MCAT Institute)
Larry L. Erickson	Flow Solver for Euler Equations on Unstructured Tetrahedral Meshes ..... 53 (with Eloret Institute)
William J. Feiereisen	Discrete Particle Simulation of Compressible Flow ..... 54 (with Stanford University)
William J. Feiereisen	Aeroassist Flight Experiment Flow Simulation ..... 55
Karen L. Gundy-Burlet	Rotor-Stator Interaction in Turbomachines ..... 66
Guru P. Guruswamy	Fluid and Structure Integration for Aerospace Applications ..... 67
Dochan Kwak	High-Lift Aerodynamic Flow ..... 105
Dochan Kwak	Space Shuttle Main Engine Flow ..... 106
Scott L. Lawrence	Integrated Hypersonic Vehicle Flow-Field Analysis ..... 110 (with MCAT Institute)
Robert D. MacElroy	Computer Simulation of Water-Membrane Interfaces ..... 122
Nagi N. Mansour	Turbulence in Compressible Fluids ..... 125
Fred W. Martin, Jr.	Space Shuttle Flow Field ..... 127 (with NASA Johnson Space Center)

	Page
W. J. McCroskey	Aerodynamics and Acoustics of Rotorcraft ..... 133 (with U.S. Army Aeroflightdynamics Directorate, AVSCOM)
W. J. McCroskey	High-Performance Rotor-Blade Tips ..... 134 (with U.S. Army Aeroflightdynamics Directorate, AVSCOM)
Parviz Moin	Turbulent Flow Over Riblets ..... 137 (with Stanford University)
Parviz Moin	Turbulence Over a Backward-Facing Step ..... 138
Parviz Moin	Aerodynamic Sound Generation ..... 139 (with Stanford University)
Parviz Moin	Shock-Wave/Turbulent-Boundary-Layer Interaction ..... 140 (with Stanford University and Center for Turbulence Research)
Robert D. Moser	Wall-Bounded Turbulent Flows ..... 141
Grant Palmer	Space Transportation Vehicle Aerothermodynamics ..... 147
Leonhard Pfister	Wave-Induced Transports ..... 152
James B. Pollack	Martian Atmosphere General Circulation ..... 155
Michael M. Rogers	Mixing and Reacting in Plane Mixing Layers ..... 164 (with Stanford University and University of Wisconsin, Madison)
William C. Rose	Hypersonic Inlet Flow Fields ..... 166
William C. Rose	National Aero-Space Plane Inlet Flow Fields ..... 168
James C. Ross	Trapped-Vortex Flows on Highly Swept Wing Configurations ..... 169
Karlin R. Roth	Validation of a Short Takeoff and Vertical Landing Model ..... 170 (with California Polytechnic State University, San Luis Obispo)
Stephen M. Ruffin	Coupled Rotation-Vibration-Dissociation Processes in Hypersonic Flows ..... 171
Lewis B. Schiff	High Alpha Technology Program F-18 Aerodynamics ..... 174
Lewis B. Schiff	High Angle-of-Attack Vortex Flow Aerodynamics ..... 175
Merritt H. Smith	YAV-8B Aircraft Flow Simulation ..... 183
Bruce F. Smith	Numerical Experiments in the Formation and Evolution of Galaxies ..... 182 (with University of Chicago)
K. Snyder	National Aero-Space Plane High-Speed Combustion Experiment ..... 185 (with NASP Joint Program Office)
Michael W. Stortz	Harrier YAV-8B Wing Aerodynamics ..... 190
Gary E. Thomas	Multi-Dimensional Simulations of Noctilucent Cloud Formation ..... 197 (with University of Colorado, Boulder)

	Page
Owen B. Toon	Stratospheric Ozone Destruction ..... 198
Arnaud Trouvé	Turbulent Premixed Combustion ..... 200 (with Stanford University)
W. R. Van Dalsem	Simulation of the Unsteady Flow about Transonic Cavities ..... 203 (with MCAT Institute)
W. R. Van Dalsem	Powered-Lift Computational Fluid Dynamics Project ..... 204 (with MCAT Institute)
Douglas L. Westphal	Tropospheric Aerosols and Clouds ..... 213
Alex C. Woo	Computational Electromagnetics ..... 219
Richard E. Young	Volcanic Aerosol Clouds in the Stratosphere ..... 223 (with Space Physics Research Institute)
 <b>NASA Johnson Space Center</b>	
Fred W. Martin, Jr.	Space Shuttle Flow Field ..... 127 (with NASA Ames Research Center)
 <b>NASA Langley Research Center</b>	
Jassim A. Al-Saadi	Transonic Reynolds Number Effects on Aircraft Configurations ..... 4 (with ViGYAN, Inc.)
John T. Batina	Euler Flutter Analysis of a Complex Aircraft Configuration ..... 7 (with Purdue University)
Richard L. Campbell	Automated Transonic Wing Design ..... 17
H. C. Chen	Euler Analysis of Turboprop and Turbofan Integration ..... 24 (with The Boeing Company and ViGYAN, Inc.)
Charles E. Cockrell, Jr.	Generic National Aero-Space Plane Forebody-Inlet Integration ..... 30
William B. Compton, III	Three-Dimensional Afterbody Flow with Jet Exhaust ..... 31 (with Analytical Services and Materials, Inc.)
Virendra K. Dogra	Rarefied Hypersonic Condition Wake Structures ..... 47 (with ViGYAN, Inc.)
J. Philip Drummond	Fuel-Air Mixing Enhancement by Jet-Shock Interactions ..... 48
Dean R. Eklund	Transpiration Cooling for Scramjet Combustor Flow Fields ..... 52 (with National Research Council)
Michael C. Fischer	F16xL Supersonic Laminar Low-Control Experiment ..... 56
Neal T. Frink	Analysis of Slender-Wing Geometries using Unstructured Grids ..... 57
Thomas B. Gatski	Compressible Turbulent Flows ..... 60

	Page
Peter A. Gnoffo	Hypersonic Flows in Chemical and Thermal Nonequilibrium ..... 61
W. L. Grose	Three-Dimensional Atmospheric Simulation Model ..... 65
H. Harris Hamilton	Radiative Structure in Aerobrake Shock Layers ..... 73 (with ViGYAN, Inc.)
Julius E. Harris	Swept-Wing Leading-Edge Transition ..... 75 (with ViGYAN, Inc.)
Lin C. Hartung	Radiation Transport around Axisymmetric Blunt-Body Vehicles ..... 76
Lawrence D. Huebner	Generic National Aero-Space Plane Fuselage Configuration Study ..... 82 (with Lockheed Engineering and Sciences Company)
Joseph W. Humphrey	Hypersonic Scramjet and Detonation Flows ..... 83 (with Advanced Projects Research, Inc. and University of Arizona)
Kenneth M. Jones	Analysis of High-Speed Civil Transport Configurations ..... 88 (with ViGYAN, Inc. and Lockheed Engineering and Sciences Company)
Ajay Kumar	Translating-Strut Scramjet Inlet ..... 104
Elizabeth M. Lee	Subsonic/Transonic Flutter Boundaries ..... 112 (with Lockheed Engineering and Sciences Company)
James M. Luckring	Advanced Computational Fluid Dynamics Applications for Complex Configurations ..... 120
M. G. Macaraeg	Ignition and Structure of a Diffusion Flame with Vortex Interaction ..... 121 (with Old Dominion University and ICASE)
M. R. Malik	Supersonic Boundary-Layer Transition on a Cone at Incidence ..... 123 (with High Technology Corporation)
M. R. Malik	Compressible Boundary-Layer Transition ..... 124 (with High Technology Corporation)
Dimitri J. Mavriplis	Multigrid Solution of the Euler Equations ..... 128 (with ICASE)
Charles R. McClinton	High Mach-Number Mixing in a Shock Tunnel Environment ..... 129 (with Analytical Services and Materials, Inc.)
Charles R. McClinton	National Aero-Space Plane Configuration Trade Studies ..... 130 (with Analytical Services and Materials, Inc.)
Charles R. McClinton	Scramjet Inlet Interaction ..... 131 (with Analytical Services and Materials, Inc.)
Charles R. McClinton	Scramjet Engine Design Optimization ..... 132 (with Analytical Services and Materials, Inc.)
James N. Moss	Hypersonic Rarefied Flow about a Compression Ramp ..... 142

	Page
Ahmed K. Noor	Thermomechanical Buckling and Post-Buckling of Multilayered Composite Panels with Cutouts ..... 146 (with University of Virginia)
Ajay K. Pandey	Thermo-Viscoplastic Analysis of an Engine-Cowl Leading Edge ..... 148 (with Lockheed Engineering and Sciences Company)
S. Paul Pao	Afterbody Aerodynamics with Canted Pitch-Vectoring Twin Nozzles ..... 149 (with Analytical Services and Materials, Inc.)
Ramadas K. Prabhu	Hypersonic-Flow Computations using Adaptive Unstructured Meshes ..... 157 (with Lockheed Engineering and Sciences Company)
C. D. Pruett	Laminar Breakdown of High-Speed Boundary-Layer Flow ..... 158 (with Analytical Services and Materials, Inc.)
R. Ramakrishnan	Shock Impingement in Hypersonic Engine Inlets ..... 159
R. Clayton Rogers	Hypervelocity Mixing and Combustion in Pulse Facility Flows ..... 165 (with University of Missouri, Rolla and Analytical Services and Materials, Inc.)
Christopher L. Rumsey	High-Alpha Flow Fields ..... 172
B. A. Singer	Formation and Growth of Hairpin Vortices ..... 180
Robert E. Smith	Grid Generation for Aerodynamic Configurations ..... 184 (with GEOLAB)
Olaf O. Storaasli	Parallel-Vector "Out-of-Core" Equation Solver ..... 189
R. C. Swanson	Simulation of Scramjet Flow Fields ..... 194
Eli Turkel	Multigrid Solution of the Navier–Stokes Equations ..... 201 (with ICASE)
Walter O. Valarezo	Multi-Element High-Lift Concepts ..... 202 (with Douglas Aircraft Company and ICASE)
Veer N. Vatsa	High-Reynolds-Number Viscous Flow over Aircraft Components ..... 205
Kenneth J. Weilmuenster	Winged Entry-Vehicle Computations ..... 211
Kenneth J. Weilmuenster	Shuttle Leaside Temperature Study ..... 212
J. A. White	Supersonic Chemically Reacting Turbulent Flow ..... 214
Richard G. Wilmoth	Shock Interactions in Hypersonic Rarefied Flows ..... 215 (with ViGYAN, Inc.)
T. A. Zang	Transition Modeling ..... 225 (with University of Maryland and University of Texas)

## NASA Lewis Research Center

Rodrick V. Chima	Prediction of Turbine Endwall Heat Transfer .....	27
Chuen-Yen Chow	Compressible Taylor–Couette Flow .....	28
	(with University of Colorado, Boulder)	
Robert G. Deissler	Sensitivity of Turbulence to Initial Conditions .....	44
Jeff L. Hansen	Incorporation of a Three-Dimensional Multistage Viscous Code into a Compressor Design System .....	74
	(with General Motors Corporation, Allison Gas Turbine Division)	
James D. Holdeman	Hot-Gas Ingestion by a Short Takeoff and Vertical Landing Aircraft in Ground Proximity .....	78
	(with University of Illinois, Urbana/Champaign)	
Osama A. Kandil	Simulation and Control of Slender Wing Rock .....	91
	(with Old Dominion University)	
Suk C. Kim	Low-Thrust Chemical Rockets .....	98
	(with Sverdrup Technology, Inc.)	
S. W. Kim	Fluid Flow of Jets in Cross Flow .....	99
Kevin R. Kirtley	Multistage Turbomachinery Flows .....	100
	(with Sverdrup Technology, Inc.)	
Sang Soo Lee	Resonant-Triad Interaction in an Adverse Pressure-Gradient Boundary Layer .....	113
	(with Sverdrup Technology, Inc.)	
William C. Rose	National Aero-Space Plane Inlet Boundary-Layer Control .....	167
Jose M. Sanz	Aerodynamic Inverse Design and Analysis for a Full Engine .....	173
T. I-P. Shih	Wankel Engine Flow Fields .....	179
	(with Carnegie Mellon University)	
Shaye Yungster	Single Expansion Ramp Nozzle with External Burning .....	224
	(with ICOMP)	

## NASA Marshall Space Flight Center

Edward J. Reske	Complex Three-Dimensional Flows in the Advanced Solid-Rocket Motor .....	160
Eric T. Stewart	Space Station Freedom Internal Flow Analysis .....	188
	(with Sverdrup Technology, Inc.)	

## NASP Joint Program Office

K. Snyder	National Aero-Space Plane High-Speed Combustion Experiment .....	185
	(with NASA Ames Research Center)	

## National Research Council

Dean R. Eklund	Transpiration Cooling for Scramjet Combustor Flow Fields .....	52
	(with NASA Langley Research Center)	

## Naval Research Laboratory

Russell B. Dahlburg	Dynamical Modeling of the Solar Atmosphere .....	37
Fernando F. Grinstein	Spatially Evolving Reactive Jets .....	64
Fazle Hussain	Chemically Reacting Free-Shear Flows .....	85
	(with University of Houston)	
K. Kailasanath	Structure and Dynamics of Multidimensional Flames .....	89
K. Kailasanath	Unsteady Nozzle Flow Fields .....	90
Carolyn R. Kaplan	Unsteady Ethylene Jet-Diffusion Flames .....	92
	(with Korea Advanced Institute of Science and Technology)	

## Naval Surface Warfare Center

Carl T. Hsieh	High Angle-of-Attack Missile Aerodynamics .....	80
Thomas T. Huang	Submarine-Appendage Design and Turbulence Modeling .....	81
	(with Jason Associates; Scientific Research Associates, Inc.; and MCAT Institute)	
Yu-Tai Lee	Unsteady Flows for Naval Applications .....	114
Tsze C. Tai	Low-Speed Aircraft Maneuvering Aerodynamics .....	195

## Nielsen Engineering and Research, Inc.

William W. Bower	Short Takeoff and Vertical Landing Aircraft Thermal/Acoustic Loads .....	12
	(with McDonnell Douglas Research Laboratories)	
Robert E. Childs	Turbulence-Model Development for Impinging Jet Flows .....	26
David Nixon	Controlling Combustion in Free-Shear Layers .....	145

## North Carolina State University

H. A. Hassan	New Approach for Transitional-Flow Modeling .....	77
--------------	---------------------------------------------------	----

## Northrop Corporation

K. Appa	Hydrodynamic Ram Structural Response Analyses .....	5
Richard D. Crouse	Fighter Acoustic-Load Predictions .....	34

## Old Dominion University

Oktay Baysal	Aerodynamic Shape Optimization .....	8
A. O. Demuren	Complex Three-Dimensional Turbulent Flows .....	46
Osama A. Kandil	Simulation and Control of Slender Wing Rock .....	91
	(with NASA Lewis Research Center)	

	Page
M. G. Macaraeg	121
	(with NASA Langley Research Center and ICASE)
<b>Oregon State University</b>	
Jeffrey R. Barnes	6
	(with NASA Ames Research Center)
<b>Pennsylvania State University</b>	
James G. Brasseur	13
	(with Georgia Institute of Technology)
Budugur Lakshminarayana	108
	(with General Motors Technical Center)
Budugur Lakshminarayana	109
Charles L. Merkle	136
<b>Pratt &amp; Whitney</b>	
Joseph L. Garrett	59
	(with General Electric Aircraft Engines)
<b>Princeton University</b>	
George E. Karniadakis	94
G. E. Karniadakis	95
<b>Purdue University</b>	
John T. Batina	7
	(with NASA Langley Research Center)
<b>QUEST Integrated, Inc.</b>	
Suresh Menon	135
<b>Rockwell International Science Center</b>	
Marek K. Bleszynski	11
C. L. Chen	23
	(with NASA Ames Research Center)
Yeu-chuan Hsia	79
	(with Rockwell International, Rocketdyne Division)
Vijaya Shankar	177
<b>Rockwell International, North American Aircraft Division</b>	
Ban H. Tran	199
Jong H. Wang	209

	Page
Chung-Jin Woan	Supersonic Laminar Flow Control Concept ..... 216
Chung-Jin Woan	Nozzle Screech Phenomena ..... 217
David T. Yeh	Steady and Unsteady Flows at High Angle of Attack ..... 222
<b>Rockwell International, Rocketdyne Division</b>	
Yeu-chuan Hsia	Full Navier–Stokes Analysis of a Three-Dimensional Scramjet Inlet ..... 79 (with Rockwell International Science Center)
S. J. Lin	Turbopump Rotor/Stator Flows ..... 119
<b>Sandia National Laboratory</b>	
Brian J. Cantwell	Simulation of a Time-Developing Incompressible Plane Wake ..... 18 (with Stanford University)
<b>Science Applications International Corporation</b>	
Sanford M. Dash	Simulation of Turbulent Jets for Aeroacoustic Applications ..... 38
Sanford M. Dash	Three-Dimensional High-Speed Plume/Propulsive Flow-Field Analysis ..... 39
<b>Scientific Research Associates, Inc.</b>	
Richard C. Buggeln	Hot-Gas-Manifold Flow Simulation ..... 15
Thomas T. Huang	Submarine-Appendage Design and Turbulence Modeling ..... 81 (with Naval Surface Warfare Center; Jason Associates; and MCAT Institute)
<b>Southern Methodist University</b>	
Fazle Hussain	Coherent-Structure Interactions with Turbulence ..... 84 (with University of Houston)
<b>Southwest Research Institute</b>	
C. S. Lin	Electron-Beam Injections from the Space Shuttle ..... 118 (with Aurora Science, Inc.)
<b>Space Physics Research Institute</b>	
Richard E. Young	Volcanic Aerosol Clouds in the Stratosphere ..... 223 (with NASA Ames Research Center)
<b>Stanford University</b>	
Diane M. Bell	Turbulent Boundary Layer with Heat Transfer ..... 9
Brian J. Cantwell	Simulation of a Time-Developing Incompressible Plane Wake ..... 18 (with Sandia National Laboratory)
Dean R. Chapman	Boost-Phase Detection Study ..... 21 (with NASA Ames Research Center)
William Feiereisen	Discrete Particle Simulation of Compressible Flow ..... 54 (with NASA Ames Research Center)

	Page
Sanjiva K. Lele	Skewed Compressible Mixing Layers ..... 115
Sanjiva K. Lele	Turbulence Effects on Stagnation-Point Flow ..... 116
Parviz Moin	Turbulent Flow Over Riblets ..... 137 (with NASA Ames Research Center)
Parviz Moin	Aerodynamic Sound Generation ..... 139 (with NASA Ames Research Center)
Parviz Moin	Shock-Wave/Turbulent-Boundary-Layer Interaction ..... 140 (with NASA Ames Research Center and Center for Turbulence Research)
Michael M. Rogers	Mixing and Reacting in Plane Mixing Layers ..... 164 (with NASA Ames Research Center and University of Wisconsin, Madison)
Arnaud Trouvé	Turbulent Premixed Combustion ..... 200 (with NASA Ames Research Center)
 <b>Stanford University School of Medicine</b>	
Dennis Sullivan	Microwave Hyperthermia Computer Modeling ..... 192
 <b>Sterling Software</b>	
G. S. Deiwert	Self-Adaptive Grid Code Applied to Complex Three-Dimensional Flows ..... 45 (with NASA Ames Research Center and Eloquent Institute)
 <b>Sverdrup Technology, Inc.</b>	
Suk C. Kim	Low-Thrust Chemical Rockets ..... 98 (with NASA Lewis Research Center)
Kevin R. Kirtley	Multistage Turbomachinery Flows ..... 100 (with NASA Lewis Research Center)
H. T. Lai	Hydrogen–Air Reacting Flow Fields in Drag Reduction External Combustion ..... 107
Sang Soo Lee	Resonant-Triad Interaction in an Adverse Pressure-Gradient Boundary Layer ..... 113 (with NASA Lewis Research Center)
David L. Rigby	Leading-Edge Heat Transfer in a Flow with Spanwise Variations ..... 161
Eric T. Stewart	Space Station Freedom Internal Flow Analysis ..... 188 (with NASA Marshall Space Flight Center)
 <b>Teledyne Brown Engineering</b>	
R. P. Roger	Jet Interaction Aero-Optic Effects on Hypersonic Interceptors ..... 163
 <b>TRW, Ballistic Missiles Division</b>	
M. I. Cruz	Flexible Aerobrake Aerothermodynamic Study ..... 35 (with TRW, Federal Systems Division)



## University of California, Santa Cruz

Jeffrey N. Cuzzi	Particle-Gas Dynamics in the Protoplanetary Nebula.....	36
	(with NASA Ames Research Center and A.T.M., Inc.)	

## University of Chicago

Bruce F. Smith	Numerical Experiments in the Formation and Evolution of Galaxies .....	182
	(with NASA Ames Research Center)	

## University of Colorado, Boulder

Chuen-Yen Chow	Compressible Taylor-Couette Flow .....	28
	(with NASA Lewis Research Center)	
Karl E. Gustafson	Airfoil Lift and Thrust Generation in Hover Mode .....	68
Gary E. Thomas	Multi-Dimensional Simulations of Noctilucent Cloud Formation .....	197
	(with NASA Ames Research Center)	

## University of Houston

Fazle Hussain	Coherent-Structure Interactions with Turbulence .....	84
	(with Southern Methodist University)	
Fazle Hussain	Chemically Reacting Free-Shear Flows .....	85
	(with Naval Research Laboratory)	

## University of Illinois, Urbana/Champaign

James D. Holdeman	Hot-Gas Ingestion by a Short Takeoff and Vertical Landing Aircraft in Ground Proximity .....	78
	(with NASA Lewis Research Center)	
J. P. Wolfe	Advanced Computational Materials Research .....	218

## University of Iowa

V. C. Patel	Hydrodynamics of Self-Propelled Bodies .....	150
Fred Stern	Free-Surface Effects on Boundary Layers and Wakes .....	187

## University of Maryland

T. A. Zang	Transition Modeling .....	225
	(with NASA Langley Research Center and University of Texas)	

## University of Missouri, Rolla

R. Clayton Rogers	Hypervelocity Mixing and Combustion in Pulse Facility Flows .....	165
	(with NASA Langley Research Center and Analytical Services and Materials, Inc.)	

## University of Texas

T. A. Zang	Transition Modeling .....	225
	(with NASA Langley Research Center and University of Maryland)	

## University of Virginia

Ahmed K. Noor	Thermomechanical Buckling and Post-Buckling of Multilayered Composite Panels with Cutouts .....	146
	(with NASA Langley Research Center)	

## University of Wisconsin, Madison

Michael M. Rogers	Mixing and Reacting in Plane Mixing Layers .....	164
	(with NASA Ames Research Center and Stanford University)	

## ViGYAN, Inc.

Jassim A. Al-Saadi	Transonic Reynolds Number Effects on Aircraft Configurations .....	4
	(with NASA Langley Research Center)	

H. C. Chen	Euler Analysis of Turboprop and Turbofan Integration .....	24
	(with The Boeing Company and NASA Langley Research Center)	

Virendra K. Dogra	Rarefied Hypersonic Condition Wake Structures .....	47
	(with NASA Langley Research Center)	

H. Harris Hamilton	Analysis of Radiative Structure in Aerobrake Shock Layers .....	73
	(with NASA Langley Research Center)	

Julius E. Harris	Swept-Wing Leading-Edge Transition .....	75
	(with NASA Langley Research Center)	

Kenneth M. Jones	Analysis of High-Speed Civil Transport Configurations .....	88
	(with NASA Langley Research Center and Lockheed Engineering and Sciences Company)	

Richard G. Wilmoth	Shock Interactions in Hypersonic Rarefied Flows .....	215
	(with NASA Langley Research Center)	

## Virginia Polytechnic Institute and State University

Robert W. Walters	Finite-Rate Chemistry Algorithms .....	208
-------------------	----------------------------------------	-----

## Vista Research, Inc.

Charles L. Rino	Scattering from Ocean Surfaces and Near-Surface Objects .....	162
-----------------	---------------------------------------------------------------	-----

## VRA, Inc.

Clark H. Lewis	Three-Dimensional Parabolized and Full Navier–Stokes Techniques .....	117
----------------	-----------------------------------------------------------------------	-----

## WL/FIMM, Wright Patterson AFB

Datta Gaitonde	Turbulent Flow Past a Complete Hypersonic Reentry Configuration .....	58
----------------	-----------------------------------------------------------------------	----

Raymond Gordnier	Unsteady Delta-Wing Flow .....	62
------------------	--------------------------------	----

Balu Sekar	Viscous Non-Reacting Flows in High-Speed Combustors .....	176
------------	-----------------------------------------------------------	-----

National Aeronautics and  
Space Administration

**Ames Research Center**  
Moffett Field, California 94035-1000



Coupled particle-gas flows in a circumstellar nebula  
prior to planetary formation.

