

PRIMARY AND SECONDARY ELECTRICAL SPACE POWER BASED ON
ADVANCED PEM SYSTEMS

N. E. Vanderborgh, J. C. Hedstrom and K. R. Stroh
Advanced Engineering Technology Group
Los Alamos National Laboratory
Los Alamos, New Mexico 87545

and

J. R. Huff
Ballard Power Corporation
Albuquerque, New Mexico 87109

INTRODUCTION

For new space ventures, power continues to be a pacing function for mission planning and experiment endurance. Although electrochemical power is a well demonstrated space power technology, current hardware limitations impact future mission viability. In order to document and augment electrochemical technology, a series of experiments for the National Aeronautics and Space Administration Lewis Research Center (NASA LeRC) are underway at the Los Alamos National Laboratory that define operational parameters on contemporary proton exchange membrane (PEM) hardware operating with hydrogen and oxygen reactants. Because of the high efficiency possible for water electrolysis, this hardware is also thought part of a secondary battery design built around stored reactants -- the so-called regenerative fuel cell. An overview of stack testing at Los Alamos, and of analyses related to regenerative fuel cell systems are provided in this paper.

Finally, this paper describes work looking at innovative concepts that remove complexity from stack hardware with the specific intent of higher system reliability. This new concept offers the potential for unprecedented electrochemical power system energy densities.

STACK TEST PROGRAM

Although contemporary designs are not space qualified, available PEM stacks are being tested to ascertain the utility of this fuel cell design for long term space power applications. Tests are conducted that operate multi-kilowatt stacks on hydrogen and oxygen. Experiments are run that explore individual cell voltages, the effects of reactant stoichiometry, thermal management, and water balances during stack operation. To date, two fuel cell stacks manufactured by Ballard Power Systems, Vancouver, B.C., have been evaluated: 1) a stack using DuPont NafionTM 117 electrolyte membranes; and 2) a similar stack formed using experimental polyperfluorosulfonic acid polymer membranes manufactured by Dow Chemical Company.

Fuel cell stack testing requires the establishment of a safe and regulated test environment. Under NASA sponsorship, Los Alamos designed and fabricated two test stations to obtain reliable test data. These test stations monitor inlet and outlet parameters, and accomplish a full mass and energy balance around the test. One test station utilizes a passive load bank to facilitate long-term, unattended testing under rather continuous conditions. The second utilizes a computer-controlled electronic load that permits programmed load changes. Because the objective of these tests is to provide data on stack life and performance decay

rates, long term testing is necessary. The tests are fully automated with a control computer that is able to diagnose faults and, if necessary, terminate a particular test.

The test configuration is shown schematically in Fig. 1. The experiment is designed to measure reactant flows, product flows, current and voltage, and heat flows. The determination of water production rates and locations helps in the evaluation of candidate membrane materials used to form PEM stacks. Electrochemical water production is frequently used to supply makeup water, making this diagnostic measurement difficult. Water flows were partitioned in the experimental design specifically to determine stack water balances.

Electrochemical water production occurs in the cathode compartment as the result of two processes, hydrogen oxidation and water generation as the result of electro-osmosis (transport of water from the anode to cathode membrane faces as the result of proton motion). Water transport occurs through motion of a hydrated proton, $H(H_2O)_n^+$. This type of transport is frequently termed "water drag." Water also moves from the wet cathode to the anode through the membrane controlled by membrane mass transfer rates.

The model predicts that appreciable fractions of water can be produced in the anode compartment, depending on the value selected for k_5 and n , where k_5 is a

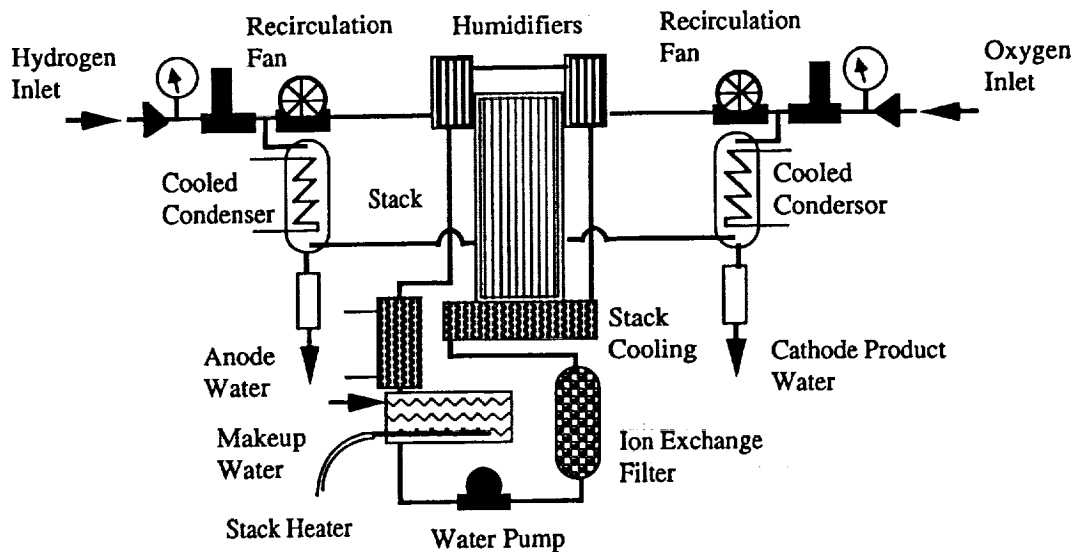

Fig. 1 Stack test schematic -- recirculation of both H_2 and O_2 and condensation of product water allows full measurement of mass and energy flows.

Stack Performance Models. An energy- and mass-balance computer model has been developed, assuming simple stack reactant and cooling flow geometry. The partitioning of the chemical hydrogen energy into heat and electrical energy is modeled. This fuel cell stack code also includes implicit terms for membrane water transport.

water mass transfer coefficient that contains both diffusive and convective terms, and n is the stoichiometry factor that describes the average proton hydration number. Model development is discussed in Refs. 1-5. Additional discussion, related to the data presented below, can be found in Ref. 1.

Stack Test Results. Early experiments showed relatively short stack lifetimes. The cause of failure was typically excess cross over, that is, excessive leakage anode to cathode resulting from one or more failed membranes. Ballard worked to correct these failures and supplied a series of modified stacks with improved membranes, electrodes, gaskets, and seals. A variety of stack clamping designs have been tested. Each time a stack was refitted to solve a known technical problem, the clock was set to zero and testing started on that new configuration. Initially failures occurred near 200 hours; the last stack tested, fitted with Nafion membranes, obtained a test duration of 1250 hours.

Likewise, ancillaries have also been improved during this test program. Initially recirculation pumps used a metal bellows design that typically lasted less than 24 hours. A whole series of recirculation pumps for both hydrogen and oxygen have been evaluated, and currently lifetimes in excess of 500 hours are predicted. The water circulation pump, used for thermal control, also now shows useful, long lifetime. These stack tests will continue until the 5,000 hour continuous operating goal is achieved.

To date, two improved 4-kW stacks have been tested -- the Ballard Mark V "Nafion" and "Dow" stacks. The Nafion stack tested has 46 single cells, using graphite bipolar plates. Each cell has an active area of 232.3 cm² (0.25 ft²). The higher performance of the Dow membrane allows that stack to contain only 40 cells. The stacks are water cooled through the use of integrated cooling hardware. Cooling water also flows through the humidification section that forms one end of the stack.

Some representative data from these tests can be found in Table I. These data were obtained operating the stacks at a constant current of 125 amps resulting in a current density of 538 mA/cm² (500 amp/ft²). Under these conditions, the

average cell voltage for the Nafion stack was 0.752 V and was 0.799 V for the Dow stack. The apparent electrical efficiency (electrical energy/HHV fuel energy) was 50.7% for the Nafion stack and 54.1% for the Dow stack.

Measurement of voltage performance under various load conditions with time is straightforward and gave, in general, expected results. The successful partition of chemical energy into electrical energy and exhaust heat routinely showed internal and external leak rates were very low on the improved stacks. Additional stack testing and performance model details can be found in Refs. 1 and 6.

POWER SYSTEM DESIGN

The preceding sections described Los Alamos activities for NASA LeRC related to contemporary PEM fuel cell components. The following sections describe system analyses and conceptual design work related to complete fuel cell power systems. The first section describes a completed study of regenerative fuel cell systems configured with evolutionary hardware. The last sections present an innovative concept for PEM fuel cell configuration and power system integration that offers the potential for both higher reliability (through use of fewer active components and reduced complexity) and unprecedented energy density in an electrochemical power system.

Regenerative Systems. Los Alamos has completed a technology assessment and trade-off study of fuel cell and electrolyzer technologies suitable for use in a regenerative fuel cell (RFC) system for Project Pathfinder [Ref. 7, see also Refs. 8-10]. The major components of an RFC system can be seen in Fig. 2. The technology assessment provides the basis for selecting the most promising candidate fuel cell and electrolyzer technologies for the Pathfinder RFC energy storage system. The trade-off study identifies the general characteristics of a 25-kW, 20,000-h energy storage system utilizing the fuel cell and electrolyzer

technologies identified in the technology assessment phase. The resulting system incorporates PEM, metal-hardware fuel cell stacks, PEM electrolysis stacks, and compressed-gas reactant storage in filament-wound, lined-composite, high-performance tanks.

ment and system integration, there would be no difference between the space and terrestrial components. Total system considerations would also be very similar. Only later would development efforts become application specific.

TABLE I Energy Balances and Water Balances from Operating PEM Fuel Cell Stacks

Energy Balance						
Membrane Type	Fuel Flow	Reject Heat	Stack Heat Loss	Anode Heat Loss	Cathode Heat Loss	Electrical Energy
Nafion	8532W (HHV)	3581W	187W	165W	284W	4327W
Dow	7395W (HHV)	3006W	160W	187W	287W	3997W
Water Balance						
Membrane Type	Water In ("makeup")	Product Water (from H ₂ flow)	Anode Water Flow	Cathode Water Flow		
Nafion	252 g/h	1,935 g/h	181 g/h	2,027 g/h		
Dow	345 g/h	1,674 g/h	453 g/h	1,633 g/h		

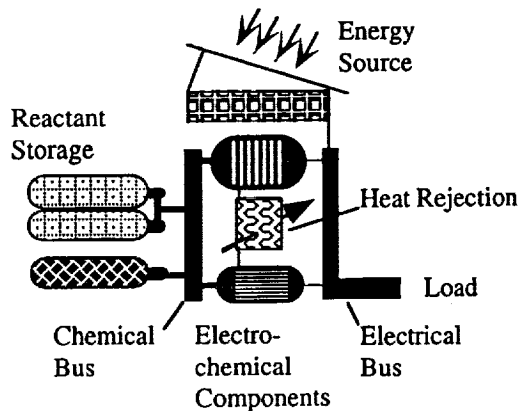

Fig. 2 Major components of a regenerative fuel cell (RFC) system.

During program deliberations, it became apparent that some terrestrial applications could profitably use an RFC system. In the initial stages of develop-

Simple, Modular PEM Systems. A space power system requires a weight- and volume-constrained, reliable and rugged power supply. Some applications have the benefit of low gravity (for example, on the lunar surface), but other applications must function in the microgravity of space. Demonstrated contemporary electrochemical systems are quite complex (especially in ancillary components contrasted to electrochemical components), making the high reliability requirements of future space missions quite challenging. However, new designs offer the potential to eliminate heavy bipolar plates and greatly simplify stack thermal management, thereby reducing system complexity. Moreover, such designs can, in concept, handle freeze-thaw cycles with little problem.

Given the basic concept of a proton exchange membrane (PEM) fuel cell op-

erating on hydrogen, we have developed a concept¹ that has the potential for exhibiting the necessary and desirable characteristics [Refs. 11 and 12]. Modularity permits both flexibility in mission planning and increasing overall reliability. Appropriate power system designs tend to integrate into human habitat modules, simplifying heat management in space environments.

The selection of compressed hydrogen storage in a composite pressure vessel presents the system designer with a sizable cylindrical section. In considering ways to optimize the packaging of an entire power system, a concept was developed that wraps the PEM fuel cell components around the exterior of the hydrogen tank. In this concept, the necessary flow fields, anode, membrane, and cathode are assembled in an annular configuration. This configuration is modular, and useful voltages can be obtained by electrically connecting the anode and cathode of adjacent modules in series. An efficient solid-state DC-DC converter raises the "stack" voltage to the desired system output voltage. Higher system powers can be obtained by incorporating additional annular PEM modules.

An individual module consists of an annular arrangement of PEM fuel cell components. From the inside out there are successive layers performing the function of the porous electrocatalytic anode, the proton exchange membrane, and the porous electrocatalytic cathode. Pressurized oxygen is recirculated over the exterior of the cathode providing the oxidant. Hydrogen is fed from the storage tank through a pressure regulator to a plenum feeding the anode flow field.

The fuel cell stack is assembled on the exterior of the hydrogen storage tank, which completely supports the annular

fuel cell modules. As a result, the fuel cell components can be very thin, providing high performance, low weight, and ease of heat removal. System start-up can be rapid because the low mass of the cell allows the membrane and catalysts to rapidly attain the optimum operating temperature. The gas-diffusion portion of the electrodes is constructed from carbon felt embedded, if necessary, with a wire-screen conductor. An optimized membrane fabricated with integral thin-film catalyst layers is hot-pressed between the carbon felt electrodes to complete the cell. No clamping forces or associated hardware are required. We envision fabrication of two carbon-felt electrode sections on a continuous electrical conductor, where one electrode section becomes the anode of the "upstream" cell and the next electrode section becomes the cathode of the "downstream" cell. The continuous conductor electrically connects the anode and cathode of adjacent modules. (The transition must also maintain anode-to-anode and cathode-to-cathode electrical separation, continuity of the anode hydrogen flow field, and separation of the anode and cathode gas flows.) The interconnection concept can be seen in Fig. 3.

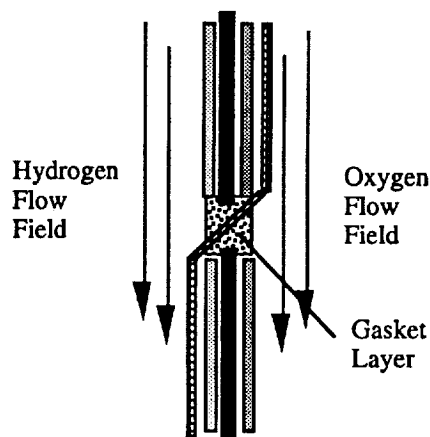

Cell Stacking Scheme

Fig. 3 Concept for interconnection of modular annular fuel cells.

The composite tank is wrapped with a non-conducting layer to prevent elec-

¹ Work performed for the US Army's Belvoir Research, Development, and Engineering Center, Fort Belvoir, VA.

trical connection between the individual module anodes. This layer is fabricated from a low-density, high-porosity, open-cell polymer that acts as the anode flow field. An additional layer of the same material covers the exterior of the stack assembly, mechanically protecting the annular modules and preventing any exterior contact from shorting cathode-to-cathode, while allowing the free flow of oxygen, product water, and excess heat through the interconnected porosity.

The recirculating cathode oxygen flow serves to remove heat caused by fuel cell inefficiencies from the stack and to sweep product water from the system. Subsequent heat exchange from the recirculating cathode flow will condense the product water vapor to liquid where it can be collected and drained to the electrolyzer water source. (In the absence of gravity, centrifugal separation of the liquid water will be required.)

A close-fitting shroud encloses the system. This shroud channels the cathode flow, supports those components not directly mounted on the tank, and provides the pressure boundary for the fuel cell system. Some fraction of the waste heat will dissipate through the shroud. Ribs on the inside of the shroud contact and retain the porous layer covering the cathode. The use of composite material for the shroud could provide exceptional stiffness and strength with little weight impact.

A connecting boss on the upper end of the composite storage tank feeds the hydrogen pressure regulator. The porous annular anode flow field is connected to the pressure-regulated hydrogen supply by a plenum. Experimental results suggest that hydrogen humidification is not required if cell current densities are kept below about 500 mA/cm^2 . A connecting boss on the bottom of the tank locates a safety valve and a valved fill port for refueling from the electrolyzer. Because water will slowly accumulate in the dead-end anode flow field, a periodic purge of a "sump" is required, with a corresponding valve and control circuit.

Safety considerations are expected to require the incorporation of hydrogen leak sensing and automatic shut-off of the high-pressure gas supply. Hydrogen sensors can be relatively simple and robust, consisting of a catalyst to enhance hydrogen oxidation and a thermocouple to sense that the exothermic reaction is occurring. This function does not significantly complicate the microprocessor control system.

Figure 4 displays the annular module PEM $\text{H}_2\text{-O}_2$ fuel cell concept. When integrated with an electrolyzer, the resulting configuration forms the reversible energy storage/generation portion of a regenerative power system.

Example System. To illustrate the concept, we have performed some scoping calculations on a 5-kW, 20,000 W-h system. To increase the power density, we have extended the design concept (described above and in Refs. 11 and 12) by "folding" the PEM membrane and electrode assemblies into two concentric cylinders. Here, one mono-layer of cells covers the hydrogen tank surface (as above), but then "crosses over" and folds back on itself with a continued mono-layer of cells lining the inside of the shroud/pressure boundary. The inner and outer PEM cells are arranged so that the cathodes face a common oxygen flow field.

For reactant storage at 3,000 psi, the resulting configuration has a shroud outer diameter of approximately 36.3 cm (14.3 in) and an overall length of about 133 cm (52.3 in). The corresponding oxygen tank has an outer diameter of 25.4 cm (10 in) and an overall length of 88.9 cm (35 in). The calculated weight of the tanks, reactants, fuel cell stack, shroud/pressure boundary and ducting is 28.7 kg (63.2 lb). Higher hydrogen storage pressure will decrease volume, but have little impact on overall weight. Including a rough estimate for the weight of those necessary components not included above, it appears that a primary (but refuelable) "battery" of this design could have an energy density (excluding

the heat rejection components) exceeding 500 W-h/kg (227 W-h/lb). Higher stored energy will increase the energy density, with the system energy density approaching that of the reactant storage subsystem. Figure 5 displays a cross-section through the example fuel cell module.

Direct radiators are large, therefore, and consequently heavy. In an application where living or equipment space must be conditioned, however, use of this "waste" energy for heating, with subsequent rejection of excess heat from the larger surface of the conditioned volume, may prove attractive.

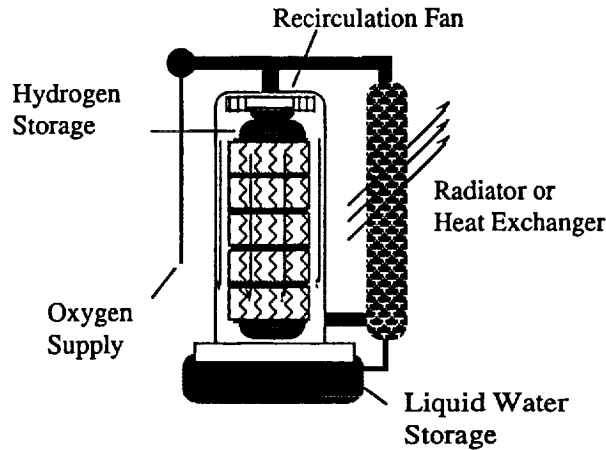

Fig. 4 Simple modular system concept using annular PEM fuel cells.

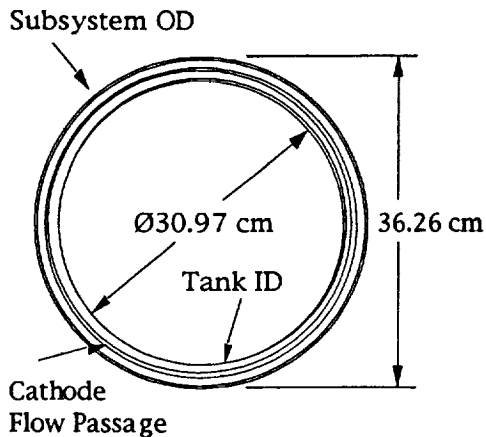

Fig. 5 Horizontal cross-section through example fuel cell system showing relative dimensions.

Heat rejection is a challenge for this technology because the optimum operating temperature of the fuel cell components is no more than about 90°C.

Regenerative System Integration.

The concept and example above require additional functions and components to complete a regenerative system (see Fig. 2 and Ref. 7). Electrolysis could proceed at the reactant storage pressure in a separate electrochemical component, with a water pump raising the water from the storage reservoir to the electrolyzer pressure. Alternately, electrolysis could occur in a reversible fuel-cell/electrolyzer at the low fuel-cell operating pressure, with the product reactants subsequently pumped up to the required storage pressure. Each approach involves challenges with high pressure pumps and interfaces. Additional design work and trade-off studies are required to optimize the overall system in terms of reliability, weight, and volume.

Concept Summary. In summary, the series-integrated annular module PEM H₂-O₂ regenerative fuel cell system

consists of the following major components:

- A fuel cell subsystem consisting of several annular PEM modules, the anode and cathode flow-field layers, the anode feed plenum, and gasketing;
- A hydrogen delivery system consisting of a high-performance graphite-composite reinforced compressed-gas storage tank with a shut-off valve, pressure regulation, a safety valve, a valved fill port, and an anode-flow-field purge valve;
- An oxygen delivery system consisting of a high-performance graphite-composite reinforced compressed-gas storage tank with a shut-off valve, pressure regulation, a safety valve, a valved fill port, a humidifier, a recirculation fan, a heat exchanger with provision for product water collection, and a shroud/pressure boundary;
- An electrolyzer system consisting of a high-pressure electrolyzer with necessary pumps, valving, water storage, and photovoltaic array;
- An electronic package containing DC-DC power conditioning, sensors, and controls;
- Mechanical supports; and
- A heat rejection radiator or connection with an integrated thermal management system (for example, providing cabin heat).

We believe that the development of the annular modular configuration described above could lead to a system that exhibits the necessary and desirable characteristics for application to a variety of space or planetary missions. This same technology would certainly have

broad uses in both the civilian and military sectors.

FUTURE WORK

As part of the ongoing effort, the Los Alamos National Laboratory will assist the NASA Lewis Research Center by conducting an electrochemical cell test program to provide critical life, reliability, and performance data currently lacking in the data base of PEM fuel cells and water electrolyzers. Los Alamos will provide technical support for fuel cell programs managed by NASA LeRC at the discretion of the NASA program manager. Los Alamos will also continue to develop, in collaboration with NASA, the single cell stand that was delivered to NASA LeRC during Fiscal Year 1992.

REFERENCES

1. Vanderborgh, N. E., Kimble, M. C., Huff, J. R., and Hedstrom, J. C., "PEM Fuel Cell Stack Heat and Mass Management," Proc. 27th Intersociety Energy Conversion Engineering Conference (IECEC), Vol. 3, pp. 407-411 (1992).
2. Nguyen, T., Hedstrom, J., and Vanderborgh, N., "Heat and Mass Transfer Design Issues in PEM Fuel Cell Hardware," Proc. American Institute of Chemical Engineers (AIChE) Meeting, San Francisco CA (November 1989).
3. Vanderborgh, N., Huff, J., and Hedstrom, J., "Heat and Mass Transfer Effects in PEM Fuel Cells," Proc. 24th Intersociety Energy Conversion Engineering Conference (IECEC), p. 1637 (1989).
4. Rieke, P., and Vanderborgh, N., "Temperature Dependence of Water Content and Proton Conductivity in Polyperfluorosulfonic Acid Membranes," J. Membrane Science, Vol. 32, pp. 313-328 (1987).
5. Nguyen, T., Guante, J., and Vanderborgh, N., "Ion Transport

Through Polyperfluorosulfonic Acid Membranes," Materials Research Society Fall Meeting, Boston, MA, (November 28-December 2, 1988).

Reactant Delivery Systems, and System Integration for Individual Power Sources," Los Alamos National Laboratory LA-UR-93-345 Revised (January 1993).

6. Vanderborgh, N., Hedstrom, J., and Huff, J., "Thermal Management of Advanced Fuel Cell Power Systems," Proc. 25th Intersociety Energy Conversion Engineering Conference (IECEC), p. 149 (1990).
7. Huff J., Vanderborgh, N., and Hedstrom, J., "Technology Assessment and Trade-off Study of Fuel Cell and Electrolyzer Technologies for the Project Pathfinder Energy Storage System," Los Alamos National Laboratory LA-UR-90-3244 prepared for the National Aeronautics and Space Administration Lewis Research Center (May 1991).
8. Huff, J., Hedstrom, J., Vanderborgh, N., and Prokopius, P., "Regenerative Fuel Cell Systems for Project Pathfinder," Proc. European Space Power Conference, Madrid, Spain (October 2-6, 1989). Published by ESA Pub. Div., Noordwijk, Netherlands, pp. 217-219.
9. Vanderborgh, N., Hedstrom, J., and Huff, J., "Electrochemical Energy Storage Using PEM Systems," Proc. European Space Power Conference, Florence, Italy (September 1991).
10. Vanderborgh, N., Hedstrom, J., and Huff, J., "Advanced Space Power PEM Fuel Cell Systems," Proc. European Space Power Conference, Madrid, Spain (October 2-6, 1989). Published by ESA Pub. Div., Noordwijk, Netherlands.
11. Vanderborgh, N. E., and Stroh, K. R., "High Energy Density Stack Design," Los Alamos National Laboratory PATENT DISCLOSURE (December 11, 1992).
12. Vanderborgh, N. E., Stroh, K. R., and Meier, R., "Analysis of Fuel Cells,

