

HIGH ENERGY DENSITY ALUMINUM-OXYGEN CELL

E. J. Rudd and D. W. Gibbons
 ELTECH Research Corporation
 Fairport Harbor, OH 44077

ABSTRACT

An alternative to a secondary battery as the power source for vehicle propulsion is a fuel cell, an example of which is the metal-air cell using metals such as aluminum, zinc, or iron. Aluminum is a particularly attractive candidate, having high energy and power densities, being environmentally acceptable and having a large, established industrial base for production and distribution.

An aluminum-oxygen system is currently under development for a UUV test vehicle and recent work has focussed upon low corrosion aluminum alloys, and an electrolyte management system for processing the by-products of the energy-producing reactions.

This paper summarizes the progress made in both areas. Anode materials capable of providing high utilization factors over current densities ranging from 5 to 150 mA/cm² have been identified, such materials being essential to realize mission life for the UUV. With respect to the electrolyte management system, a filter/precipitator unit has been successfully operated for over 250 hours in a large scale, half-cell system.

INTRODUCTION

An alternative to a secondary battery as the power source in a vehicle is a fuel cell. It has been shown that metals such as aluminum, zinc, lithium and iron may be used as a "fuel" in the fuel cell or metal-air battery. Aluminum is a particularly attractive candidate. The metal has both high energy and power densities, it is environmentally acceptable (as are the products of the cell reaction), it is easy to handle and has a large, industrial base for production and distribution.

The chemistry that is involved in the aluminum-air cell is shown by the following equations:

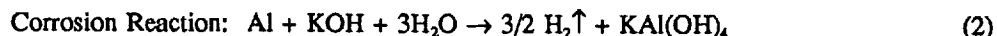
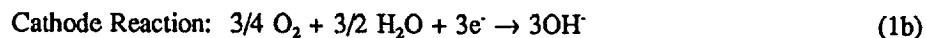
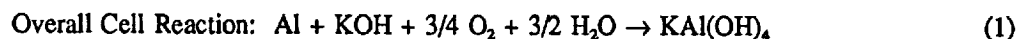

In operation, aluminum is dissolved (Equation 1) forming a soluble aluminate species and consuming the alkali metal hydroxide in the electrolyte. A corrosion reaction also occurs in the aqueous electrolyte, again forming the soluble aluminate together with hydrogen gas (Equation 2). This corrosion reaction is a coulombic inefficiency and, therefore, must be minimized. As the battery operates, the conductivity of the electrolyte decreases until precipitation or crystallization of aluminum trihydroxide occurs (Equation 3), replenishing "free" hydroxide. Thus a "steady state" condition may be achieved with respect to electrolyte composition and conductivity, at which time the electrolyte will contain crystals of aluminum trihydroxide. As will be discussed later, controlling the electrolyte composition is very important.

The reaction at the cathode is the electroreduction of oxygen, which can only be sustained at practical rates by using a gas diffusion electrode. A three-phase boundary between the catalyst, electrolyte and reactant oxygen

must be established and this demands a unique electrode structure. It is known that the presence of carbon dioxide in the air feed stream to the cathode can lead to loss of performance, due probably to precipitation of alkali metal carbonates within the structure of the electrode. Therefore, the battery system must include a method to reduce the levels of carbon dioxide in the air feed steam, or ideally to remove it entirely. For a power source in an underwater vehicle, the fuel is necessarily oxygen, probably cryogenic oxygen, and removal of carbon dioxide is not required.

Aluminum cannot be electrodeposited from aqueous solutions, so that the aluminum-air battery is not a true secondary battery. The anode must be replaced mechanically, requiring novel features in the cell design, but offering relatively rapid refuelability.

The aluminum-air battery is, therefore, a multi-component system (Figure 1) and programs to develop this technology have necessarily focussed upon:

1. The Electrodes
2. The Electrolyte Management System, i.e., the separation of crystals of aluminum trihydroxide from the electrolyte and control of the composition and conductivity of that electrolyte
3. Cell Design to allow replacement of the anode material
4. The Auxiliary System, including a heat exchange unit, safe handling and/or disposal of hydrogen gas and control of carbon dioxide in the air feedstream

This paper will provide a brief review and summarize the recent progress made in the first two areas, the electrodes and the Electrolyte Management System.

THE ELECTRODES

Development of Aluminum Alloys

Aluminum reacts rapidly and irreversibly with oxygen to form a strongly-adhering oxide film, which largely determines the electrochemical behavior in aqueous electrolytes. Macdonald [1] has described aluminum as a passive metal, which displays an active-to-passive transition, a passive region and transpassive dissolution. The current-potential relationship can be represented schematically as in Figure 2 and a superior battery anode should, therefore, exhibit the following characteristics:

1. A very negative activation potential, (E_{CRIT})
2. High discharge currents at potentials only slightly anodic to the activation potential, i.e., a low value for the slope b ,
3. A low corrosion current, (I_{CORR}), which remains low or decreases at the more anodic potentials required for dissolution.

Modification of the behavior of the oxide layer through the formation of alloys of aluminum has been extensively explored [2-6]. The incorporation of small concentrations of metals such as magnesium, calcium, zinc, gallium, indium, thallium, lead, mercury, and zinc, usually in combinations as ternary or quaternary alloys, has been effective in achieving activation (high rates of dissolution) and inhibition of corrosion.

The presence of certain impurities in the aluminum can markedly affect the electrochemical behavior. For example, the corrosion rate is particularly sensitive to the concentration of iron in the metal. Using manganese as an alloying element has been shown to reduce the rate of corrosion of primary aluminum (99.9% purity), which contains high levels of iron [7]. Typically alloy fabrication has used metal of higher purity, e.g., 99.995% and 99.999%.

The transition from fabrication at the laboratory-scale (bookmold ingots of weight approximately 3-5 lbs.) to the pilot-scale (150-250 lb. ingots) is not always readily achieved. The electrochemical performance of the large ingot material can be variable and often is inferior to that of the bookmold material. That the fabrication "practice" and thermomechanical processing is important is illustrated by the data presented as Table 1 [8]. This shows the electrochemical performance of an indium-manganese-magnesium alloy, prepared as a 150 lb. ingot by direct chill casting and processed in sections to give different grain structures and microstructures (Figure 3). For example, using the process IC, i.e., cooling slowly from the solutionizing temperature and only cold-working (cold-rolling) the alloy, will lead to an unrecrystallized structure with some precipitation of the alloying elements.

In the recent program to develop a power source for an unmanned underwater vehicle [9], emphasis has been upon mission life or the range achieved by the vehicle. It was then essential to identify an alloy with a low rate of corrosion in order to maximize the utilization of the metal fuel. An added advantage was that the hydrogen gas handling requirements within the system are minimized. The polarization characteristics remained important, as well as realizing a uniform, "smooth" surface as dissolution proceeded.

The electrochemical characteristics of three candidate alloys are presented as Table 2, showing the dependence of the anode potential and corrosion current density upon the external load. The percent utilization realized with these alloys is presented as Table 3, together with data for pure aluminum and earlier alloy materials. The target levels of performance are also shown in the table and are based upon a corrosion current density of 5 mA/cm² or less over the operating range of current densities.

The alloy materials were fabricated as large ingots by conventional industry practice, although the data shown as Table 2 was obtained in laboratory-scale cells. Alloy ERC-4 is clearly superior, meeting utilization requirements while maintaining acceptable polarization behavior. Alloys ERC-2 and ERC-3 closely approached the utilization targets but the former material showed poor physical characteristics during dissolution/corrosion due to intergranular attack. This was particularly serious in the full-scale single cell studies.

Development of Air Cathodes

The air cathode used in the recent programs to develop the aluminum-air or aluminum-oxygen battery as the power source in (a) an electric vehicle [8], and (b) an unmanned, underwater vehicle [9] is a high performance, two layer structure. The development of air cathode technology, involving ELTECH Research Corporation and Case Western Reserve University, has been described elsewhere [8,10] and has led to the present electrode, which is a laminate of

- (a) an active layer, containing the catalyst (cobalt tetramethoxyphenylporphyrin) absorbed onto a graphitized carbon black, pyrolyzed and coated with a perfluorinated ionomer,
- (b) a gas supply layer, which is a mixture of the graphitized carbon black and teflon, and
- (c) two nickel meshes, one on the gas side for mechanical support and the second on the electrolyte side for current distribution or collection.

This type of electrode has shown excellent extended performance under both constant current operation (Figure 4) and cyclic operation (Figure 5).

For use in the unmanned, underwater vehicle, it is necessary that the transport of oxygen gas through the electrode into the electrolyte be prevented, or at least minimized. A porous barrier layer was added, bonded to the nickel mesh and surface of the active layer. During operation the pores of this layer readily fill with electrolyte, providing an effective barrier to the transport of oxygen gas into the electrolyte.

The performance of the modified electrode, over the range of current densities of interest, is shown as Table 4.

THE ELECTROLYTE MANAGEMENT SYSTEM

Development of the Filter/Crystallizer

The Al/Air battery may operate in two basic modes, batch or steady state, depending on how one desires to treat the aluminate species generated in reactions 1 and 2. In the batch mode, fresh electrolyte is charged into the system and operation continues until the level of dissolved aluminate reaches saturation. This situation corresponds to an end of charge condition; no solids are formed during batch operation. Conversely, a near constant electrolyte composition can be maintained in the steady state mode by promoting the crystallization of the aluminate species into an insoluble hydroxide called hydrargillite, $\text{Al}(\text{OH})_3$ (equation 3). During the cell refueling operation, the electrolyte tank is emptied and the $\text{Al}(\text{OH})_3$ crystals may be sent to a Hall-Heroult cell for processing back into aluminum.

The performance of a batch operation battery is electrolyte volume limited and off-board facilities to process the supersaturated solutions of potassium aluminate would be required. Steady state operation produces a battery with greater capacity and a more constant voltage profile versus time for a given load. By promoting the crystallization of $\text{Al}(\text{OH})_3$ and generating KOH, the energy capacity of the battery is significantly enhanced for a given electrolyte tank volume. This fact is illustrated in Figure 6 for a 200 liter electrolyte tank where battery capacity is plotted versus packing factor (P_f). The packing factor is a convenient way of representing filter/crystallizer performance. It may be defined as

$$P_f = \frac{V_E + V_C}{V_C}$$

where V_E is the electrolyte volume and V_C is the volume of crystals. A packing factor of 1 corresponds to a solid mass of $\text{Al}(\text{OH})_3$ with no entrained electrolyte. A value of 2 in the figure means that the electrolyte tank is full of a dense, paste-like slurry at the end of mission, but only 100 liters of that mass is actually $\text{Al}(\text{OH})_3$ crystals.

Solomon Zaromb and R. A. Foust, Jr. first described operation of Al/Air batteries with electrolyte regeneration by precipitation of $\text{Al}(\text{OH})_3$ in 1962 [11,12]. Since then a variety of crystallizer/separator techniques have been attempted to control the electrolyte aluminate concentration as indicated in Table 5 [13-17]. With the exception of the filtration techniques, all of these methods have been rejected for propulsion applications because of weight, volume, and/or energy considerations.

Previous studies have shown that optimization of Al/O_2 energy and power density requires an electrolyte management system [18,19]. ELTECH's patented filter/crystallizer unit [20] maintains system simplicity, since only a filter and two additional valves are required. Mission duration is increased by continuously regenerating potassium hydroxide for subsequent reaction at the anode and storing cell discharge products compactly as a crystalline hydroxide species, $\text{Al}(\text{OH})_3$. Continuous crystallization maintains a high and nearly constant electrolyte conductivity; therefore, stack voltage remains steady throughout the discharge cycle. As the stack is discharged, a crystal cake forms and gradually increases in thickness with a subsequent increase in pressure drop across the filter. When the pressure drop reaches a predetermined level, the cake is pulsed off the filter by backflushing (flow reversal) to settle in the bottom of the tank.

Filter/Crystallizer Operation

Test equipment utilized to investigate behavior of the filter/crystallizer is shown in Figure 7. Total hydroxide concentration is kept constant by water addition and backflush cycles are produced by 2-way solenoid "backflush valves." Figure 8 displays the results of a filter test for a power load of 40.3 Amps. This experiment was run in conjunction with an aluminum half cell driven by a power supply in which H_2 was evolved at the nickel counter-electrode. Electrolyte conductivity was continuously monitored by a Foxboro model 872 conductivity meter with an electrodeless sensor, 871EC.

Backflushes occurred at 5 psi or 202 Ah, whichever came first and, in the figure, a hollow circle indicates a backflush. A software bug prevented the system from backflushing properly for the first 20 hours. Operation began again at 40 hours after the necessary software modifications were made. Despite the system upsets the filter performed well for more than 250 hours, maintaining the conductivity between 300 and 400 mS/cm. Filter lifetime depends primarily on three factors:

- 1) the anode alloy,
- 2) the filter material, and
- 3) the backflush algorithm

ALUMINUM-OXYGEN SINGLE CELL PERFORMANCE

Full-scale aluminum-oxygen cells (with an active electrode area of 690 cm²) have been integrated with the filter/crystallizer unit for a series of studies. The cell featured a fixed anode with backside temperature control and a modified AE100 cathode to minimize electrolyte leakage and oxygen gas blowthrough. The anode alloy, ERC-4, was manufactured from high purity aluminum as a 150 lb. ingot using conventional practice and thermomechanical processing. The experimental apparatus is that used in the filter/crystallizer studies (Figure 7), but incorporates the Al/O₂ single cell. The process streams were all maintained at 50°C with an oxygen gas flowrate of 1.75x stoichiometry. The unreacted oxygen was recycled to the cell using a peristaltic pump.

This single cell was operated at a constant current density of 50 mA/cm², drawing more than 5,000 amp-hours, during which time the cell voltage declined from 1.43 volts to 1.3 volts (see Figure 9). This decline in the cell voltage may be attributed to the increasing interelectrode gap in this particular (fixed electrode) cell design. A movable anode prevents this ohmic voltage loss and is essential to achieve the required high energy density. The data shown represents an energy yield of 3.9 kilowatt-hours/kilogram aluminum, which is significantly better than that obtained with earlier aluminum alloys.

Polarization data was recorded periodically and is presented as Figure 10 at two time and conductivity intervals. The fact that the data obtained approaches the target performance for a single cell is most promising, since, as stated above, the cell uses fixed anodes. The large decrease in cell voltage observed from open circuit to 25 mA/cm² is a consequence of the irreversibility of both the aluminum anode and the oxygen cathode reactions. At higher current densities the slope of the polarization curve decreases markedly, the voltage presumably being dominated by the concentration and ohmic overpotentials in the cell.

CONCLUSIONS

A brief review of the aluminum-oxygen cell and related technology has been presented. Two areas of this technology, considered to be critical to successful application in vehicular propulsion systems, were identified. Firstly, the fabrication of high performance aluminum alloys was demonstrated, using conventional industry practice. The alloys provided the required utilization targets for the aluminum fuel in operation in a vehicle. Secondly, an effective electrolyte management system has been developed, providing the necessary control of composition and conductivity of the electrolyte as well as removing the solid by-products of the energy-producing reactions. These developments led to the integration of a single, full-size aluminum-oxygen cell with the filter/precipitator unit to give over 5,000 ampere-hours of operation, with an overall energy density of 3.9 kilowatt-hours/kilogram aluminum.

ACKNOWLEDGEMENTS

A substantial part of this work was performed under the auspices of the Defense Advanced Research Projects Agency, Contract Number MDA-972-91-C-0040.

REFERENCES

1. "Development and Evaluation of Anode Alloys for Aluminum-Air Batteries," Final Report to Lawrence Livermore National Laboratory from ELTECH Research Corporation, Contract Number 1806205, Section VIII B, November 1987.
2. J. T. Reding and J. J. Newport, *Materials Production*, 5, 15 (1966).
3. T. Sakano, K. Toda, and M. Hanoda, *Materials Production*, 5, 45 (1966).
4. "The Metallurgy and Electrochemistry of the Aluminum Anode," a report from the Fontana Corrosion Center for ELTECH Research Corporation, May 1984.
5. "The Behavior of Aluminum in Aqueous Solutions," a report to the Norwegian Defense Research Establishment by T. Valand, NRDE-PUBL-81/1003, 1981.
6. "Aluminum-Air Battery Development," Final Report to Lawrence Livermore National Laboratory from ELTECH Research Corporation, Contract Number 1806205, Sections VIII C, VIII D, and X, November 1987.
7. "Effect of Manganese Additions on the Performance of Aluminum Anode Alloys," a progress report to Lawrence Livermore National Laboratory by D. H. Scott, UCRL-15473, May 1982.
8. "Development of Aluminum-Air Batteries for Application in Electric Vehicles," Final Report to Sandia National Laboratories from ELTECH Research Corporation, Contract Number SAND 91-7066, December 1990.
9. "An Aluminum-Air Fuel Cell Power System for an Undersea Vehicle (UUV)," Defense Advanced Research Projects Agency, Contract Number MDA-972-91-C-0040, July 1991.
10. "Status of the Aluminum-Air Battery Technology," Proceedings of the Workshop on Structure Effects in Electrocatalysis and Oxygen Electrochemistry, Volume 92-11, Published by the Electrochemical Society, Inc., NJ (1992).
11. S. Zaromb, "The Use and Behavior of Aluminum Anodes in Alkaline Primary Batteries," *J. Electrochem. Soc.*, 109, 1125, (1962).
12. S. Zaromb and R. A. Foust, Jr., "Feasibility of Electrolyte Regeneration in Aluminum Batteries," *J. Electrochem. Soc.*, 109, 1191, (1962).
13. A. Maimoni, "Lamella Settlers: Material Balances and Clarification Rates," Lawrence Livermore National Laboratory, UCRL-95924, 1987.
14. A. Maimoni, "Crystallization of Aluminum Hydroxide in the Aluminum-Air Battery: Literature Review, Crystallizer Design and Results of Integrated Systems Tests," Lawrence Livermore National Laboratory, UCRL-53843, March 1988.
15. A. Maimoni, "Aluminum-Air Battery Crystallizer," Lawrence Livermore National Laboratory, UCRL-95923, January 1987.
16. T. G. Swansiger and C. Misra, "Development and Demonstration of Process and Components for the Control of Aluminum Air Battery Electrolyte Composition Through the Precipitation of Aluminum Trihydroxide," Alcoa Labs, Final Report under Subcontract No. 5724709, available as UCRL-15503, (1982).
17. M. Balasko, R. J. Adler, R. V. Edwards, and S. B. Adler, "Initial Studies of Particle Trapping in Impeller Fluidizers," *AIChE Symposium Series*, 83, 112, (1987).

18. D. W. Gibbons, M. J. Niksa, and S. Sinsabaugh, "*Aluminum/Oxygen Fuel Cell with Continuous Electrolyte Management*," *Unmanned Systems*, **9**, 38, (1991).
19. A. Maimoni and J. F. Cooper, "*Development of the Aluminum-Air Battery for an Electric Vehicle*," *Energy Technology Review*, Lawrence Livermore National laboratory, p. 9, April 1988.
20. R. J. Coin, C. W. Brown Jr., and J. M. Nosal, "*Metal-Hydroxide Crystallizer and Filter*," U.S. Patent 4,994,332, (1991).

TABLE 1

Electrochemical behavior of an InMgMn alloy - effects of thermomechanical processing

	Open Circuit		100 mA/cm ²		200 mA/cm ²		300 mA/cm ²		400 mA/cm ²	
	Potl	Corr	Potl	Corr	Potl	Corr	Potl	Corr	Potl	Corr
From Process 1A*	-1.72	51.0	-1.70	35.0	-1.71	70.0	-1.66	58.5	-1.60	65.0
From Process 1B*	-1.77	38.1	-1.74	69.0	-1.56	20.0	-1.41	22.0	-1.27	10.0
From Process 1C*	-1.75	27.7	-1.67	31.9	-1.50	20.6	-1.38	17.5	-1.25	14.0
From Process 2*	-1.76	30.4	-1.71	41.0	-1.69	47.4	-1.65	58.0	-1.60	60.9

Electrolyte: 5M KOH, 60°C
 Potential: Volts vs. Hg/HgO reference electrode
 Corrosion: Expressed as a current density, mA/cm²
 *as in Figure 3

TABLE 2

Electrochemical performance of selected alloys

	at 7 mA/cm ²		at 25 mA/cm ²		at 75 mA/cm ²		at 125mA/cm ²		at 175 mA/cm ²	
	Potl	Corr	Potl	Corr	Potl	Corr	Potl	Corr	Potl	Corr
ERC-2	-1.78	4.8	-1.62	2.4	-1.47	2.7	-1.42	2.25	-1.39	1.25
ERC-3	-1.77	3.5	-1.71	1.3	-1.63	0.5	-1.35	2.0	-	-
ERC-4	-1.76	3.0	-1.58	0.2	-1.57	0.1	-1.52	0.8	-1.49	0.1

Electrolyte: 4M KOH containing 1.5M dissolved aluminum, 50°C
 Electrode Area: 6.45 cm²
 Potential: Volts vs. Hg/HgO reference electrode
 Corrosion: Expressed as a current density, mA/cm²

TABLE 3

Corrosion characteristics of selected aluminum alloys

	% Utilization* at			
	5 mA/cm ²	50 mA/cm ²	100 mA/cm ²	200 mA/cm ²
High Purity Aluminum	0.05	31	54	76
ERC-1	12.5	56	71	81
Alcan BDW	19	72	83	92
ERC-2	43	94	97	98
ERC-3	59	98	98	-
ERC-4	62.5	~99	~99	~100
Performance Target	>50	>91	>95	>97.5

Electrolyte: 4M KOH containing 1.5M dissolved aluminum
 Temperature: 50°C

*% Utilization = $\frac{\text{Faradaic Dissolution Current (load)}}{\text{Faradaic Dissolution Current} + \text{Corrosion Current}}$ %

TABLE 4

Electrochemical performance of the modified cathode

	Cathode Potential* (volts) vs. Hg/HgO at				
	Open Circuit	25 mA/cm ²	50 mA/cm ²	100 mA/cm ²	200 mA/cm ²
After 27 hours at 50 mA/cm ²	+0.06	-0.07	-0.1	-0.13	-0.19
After 313 hours at 50 mA/cm ²	+0.06	-0.06	-0.09	-0.12	-0.18
After 1000 hours at 50 mA/cm ²	+0.07	-0.07	-0.09	-0.13	-0.21

Electrolyte: 4M KOH at 60°C
 Gas: Oxygen, dry
 Electrode Area: 14 cm²
 *Corrected for IR contributions

TABLE 5

Alternative Solids Separation Techniques

•Gravity Settler	•Wound Cartridge Filter
•Lamella Settler	•Cross Flow Filter
•Hydrocyclone	•Helipump Impeller Fluidizer
•Centrifuge	•Poulos Separator

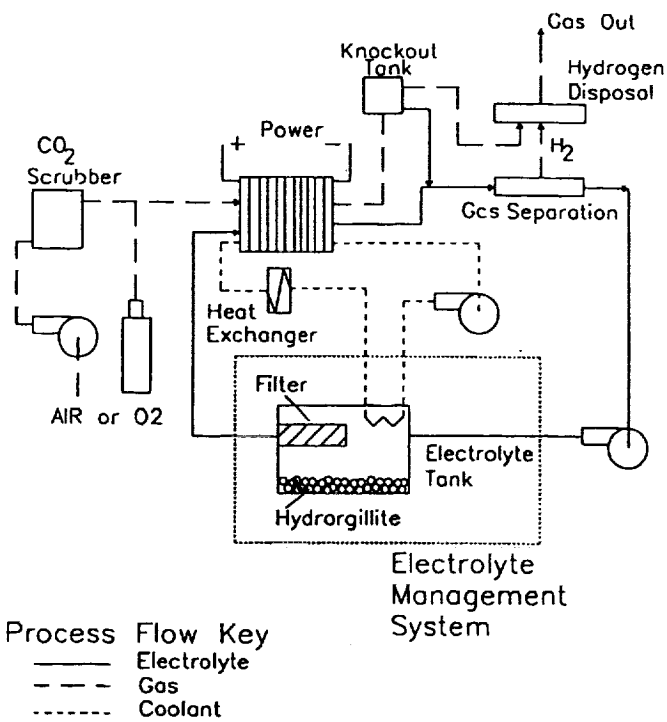

Fig. 1. -- Schematic Representation of the Aluminum-Oxygen cell system.

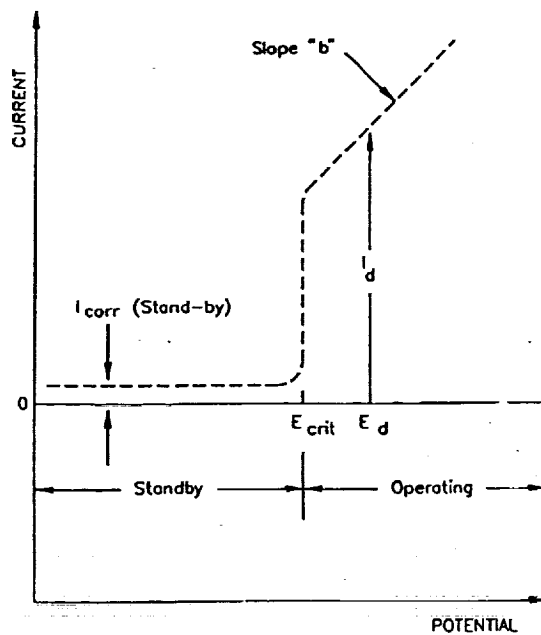

Fig. 2. -- Schematic representation of the current-potential relationship for aluminum in alkaline solutions.

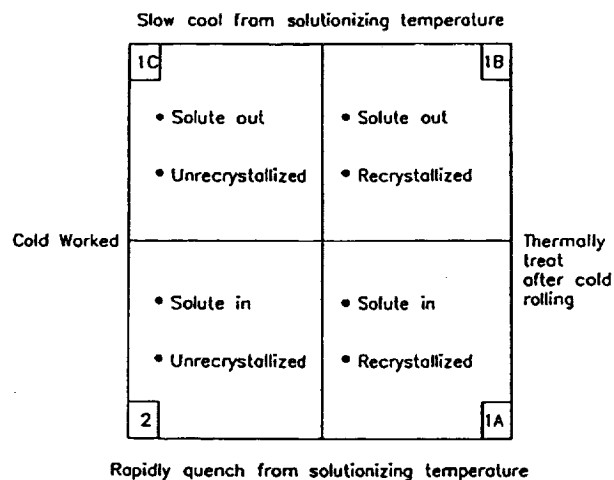

Fig. 3. -- Matrix to show the four types of structures resulting from the processing variations.

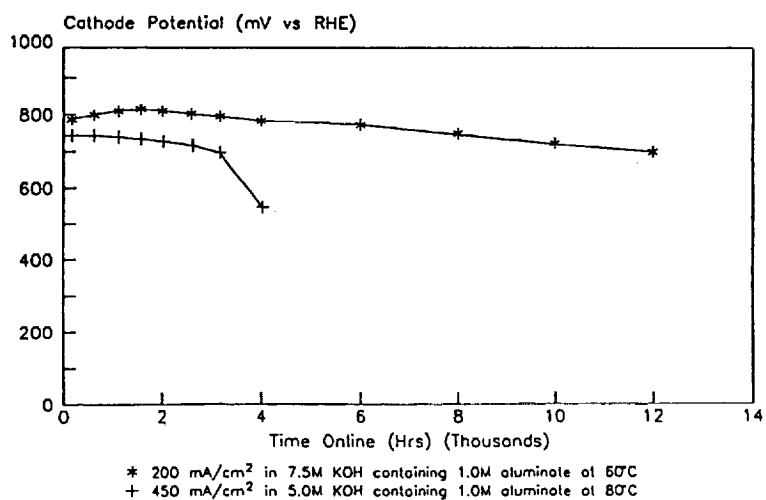

Fig. 4. -- Performance of polymer-modified air cathodes - constant current operation.

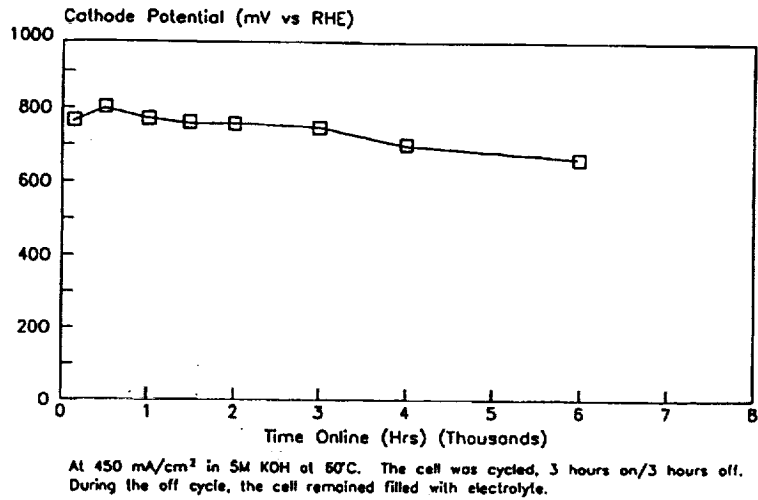
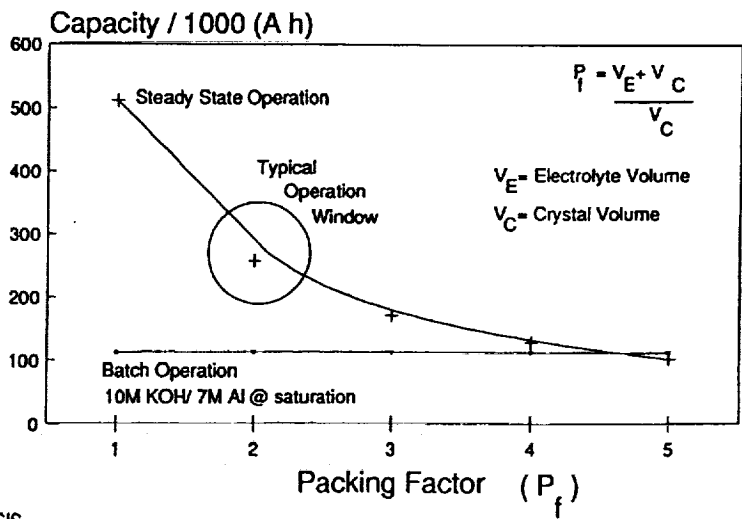

Fig. 5. -- Performance of polymer-modified air cathodes - cyclic operation.



BASIS
Electrolyte Tank = 200 liters

Fig. 6. -- Capacity for a given electrolyte volume.

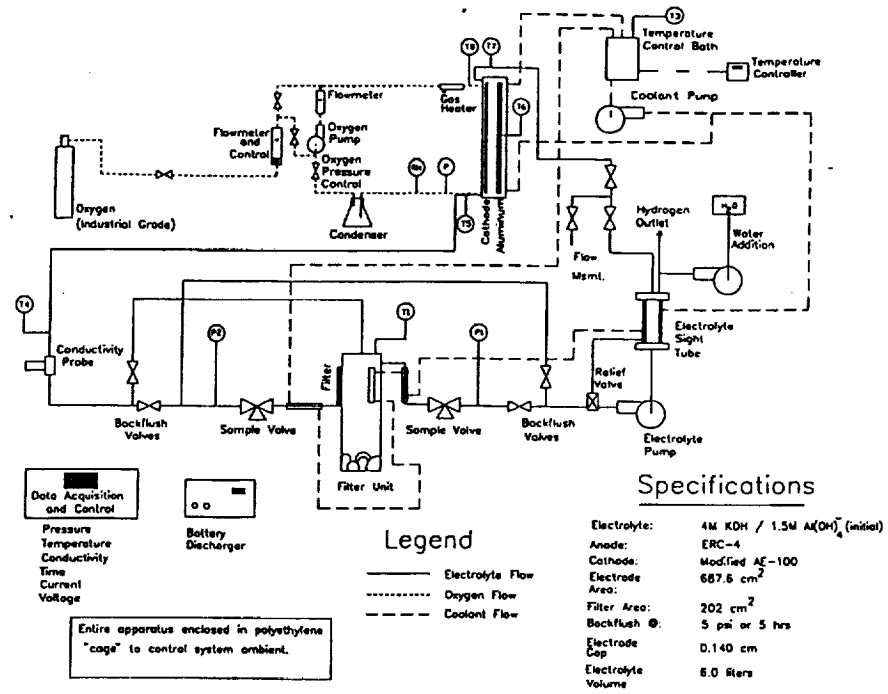

Fig. 7.-- Al/O₂ single cell test apparatus.

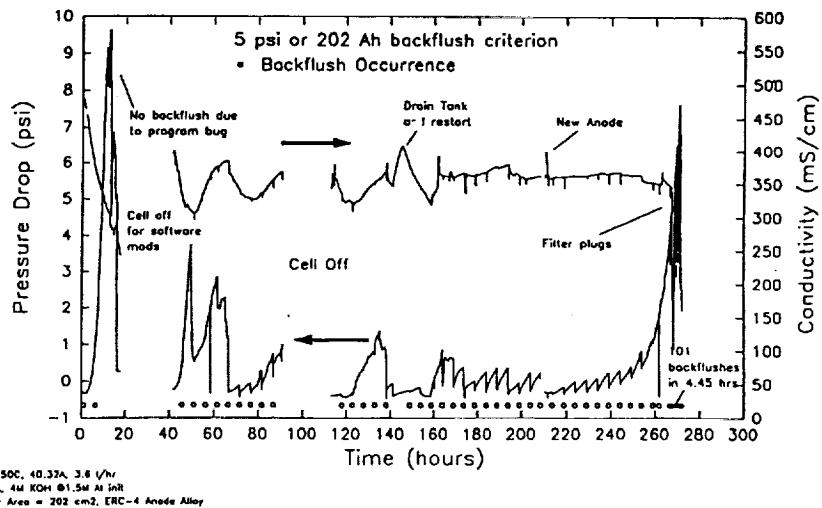

Fig. 8.-- Filter/crystallizer test.

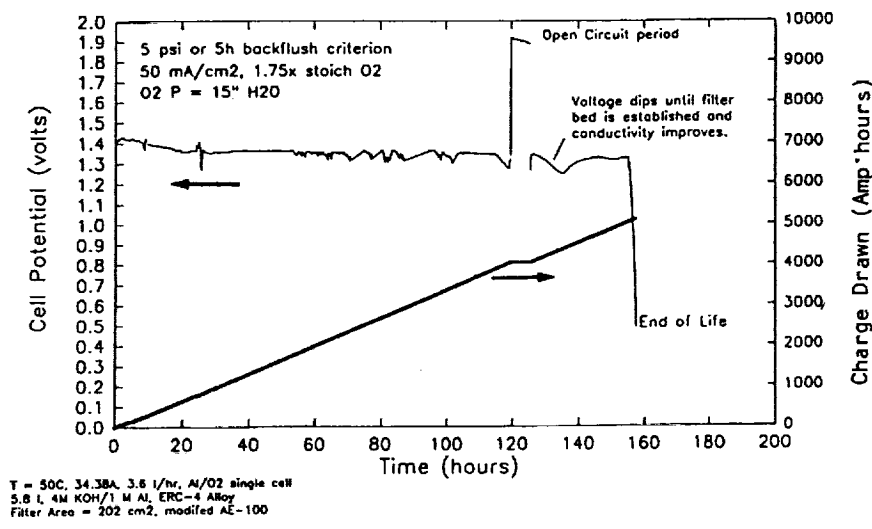

Fig. 9. -- Al/O₂ single cell test.

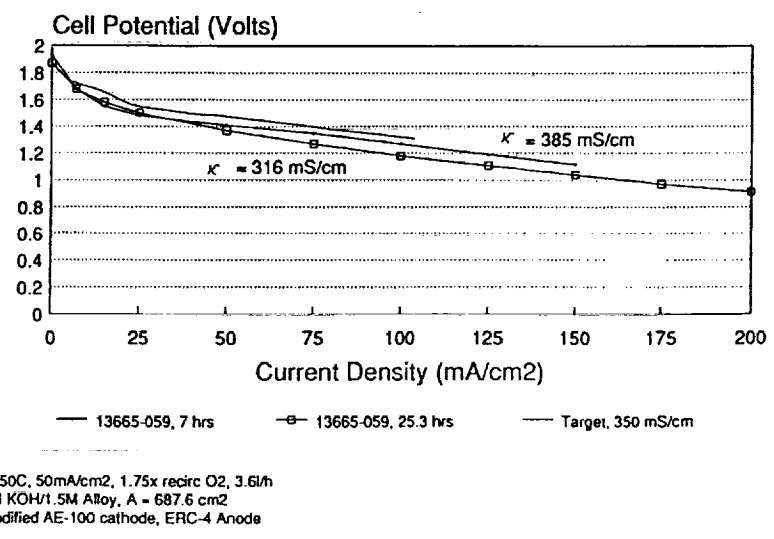

Fig. 10. -- Full scale Al/O₂ single cell results polarizations during mean power test.