

Enhanced Image Capture Through Fusion

Peter J. Burt
Keith Hanna
Raymond J. Kolczynski
David Sarnoff Research Center

42-35
205742
P 1

ABSTRACT

Image fusion may be used to combine images from different sensors, such as IR and visible cameras, to obtain a single composite with extended information content. Fusion may also be used to combine multiple images from a given sensor to form a composite image in which information of interest is enhanced.

We present a general method for performing image fusion and show that this method is effective for diverse fusion applications. We suggest that fusion may provide a powerful tool for enhanced image capture with broad utility in image processing and computer vision.

The Fusion Task

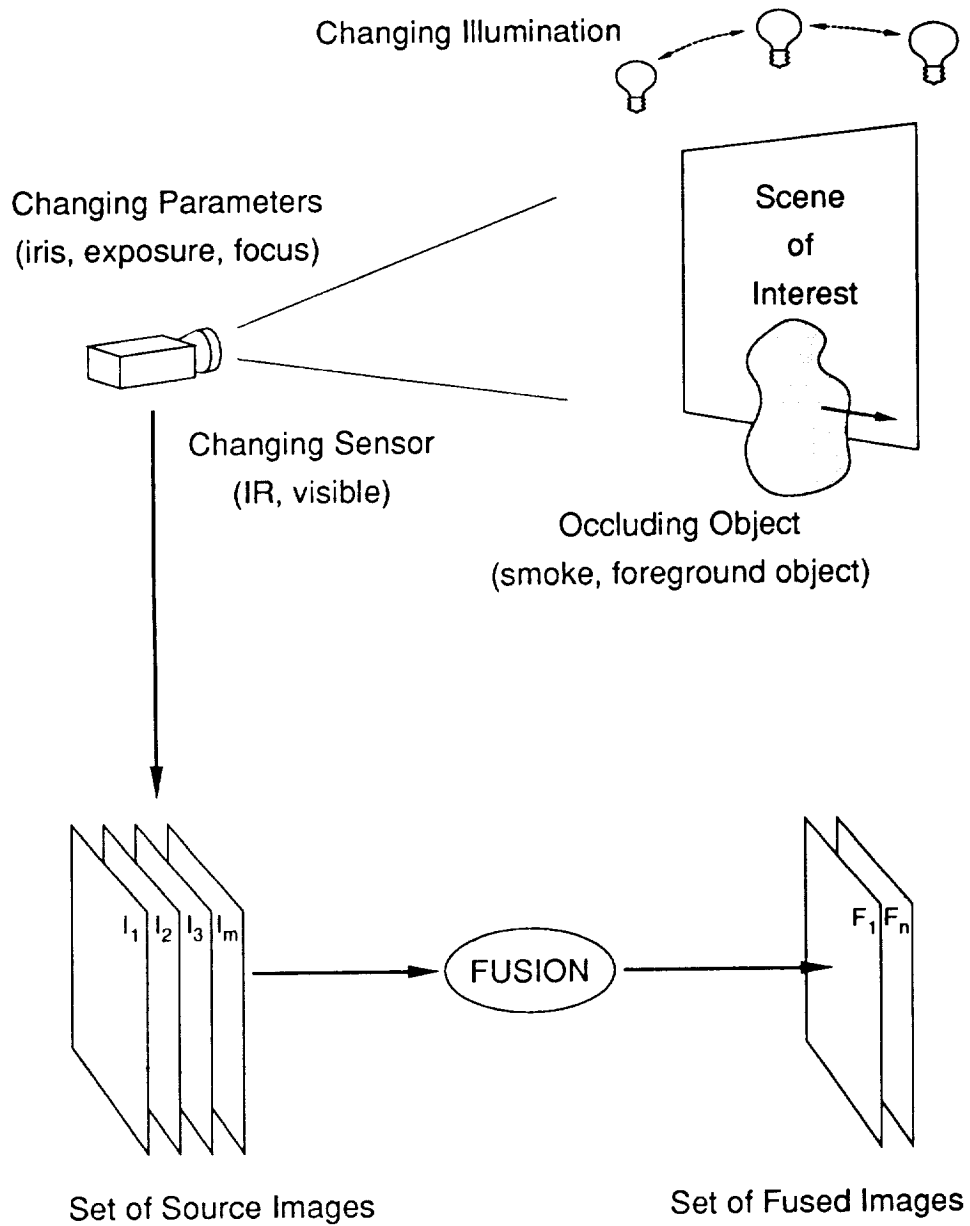
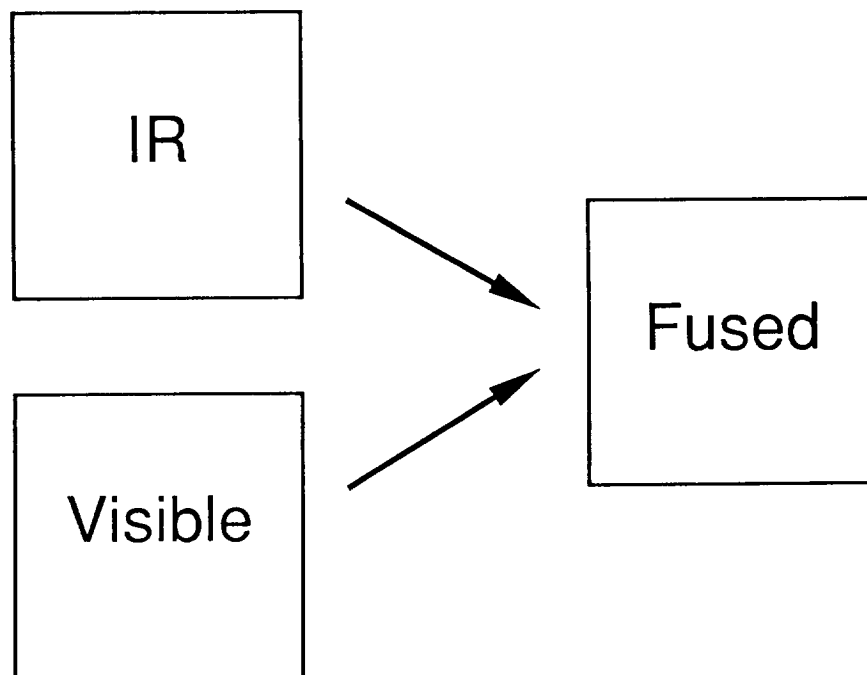

Image Fusion: Objectives

Combine two or more source images to obtain a single composite with extended information content.



Requirements

- retain all useful information from the source images
- not introduce fusion artifacts into the combined image
- look "natural"

Technical Challenge

Pixel averaging, results in ...

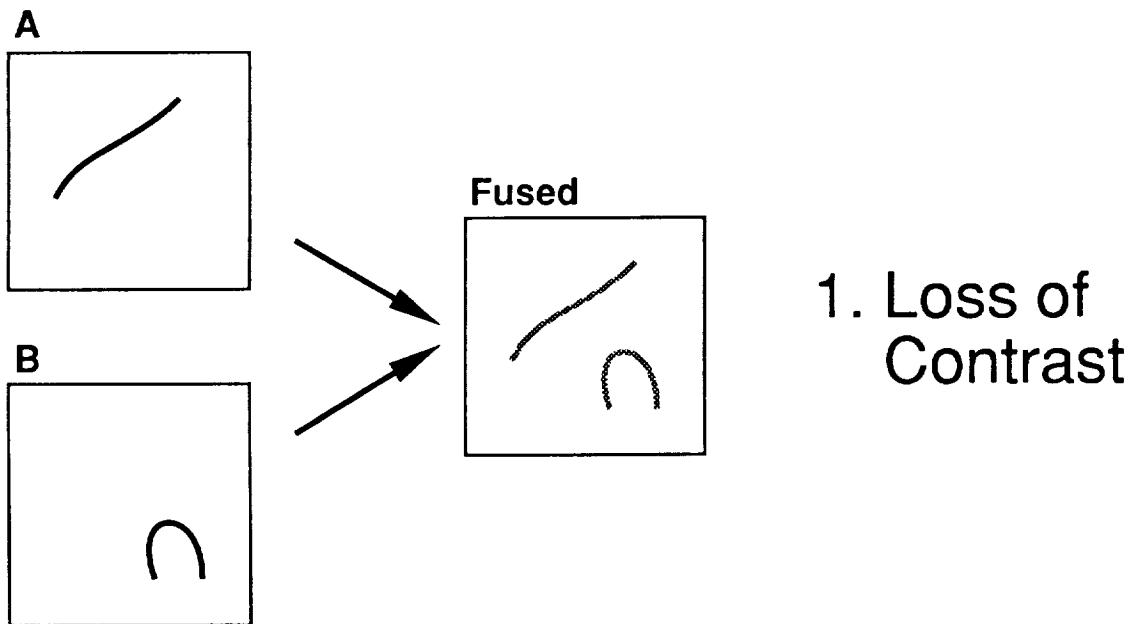

Technical Challenge

Pixel averaging, results in ...

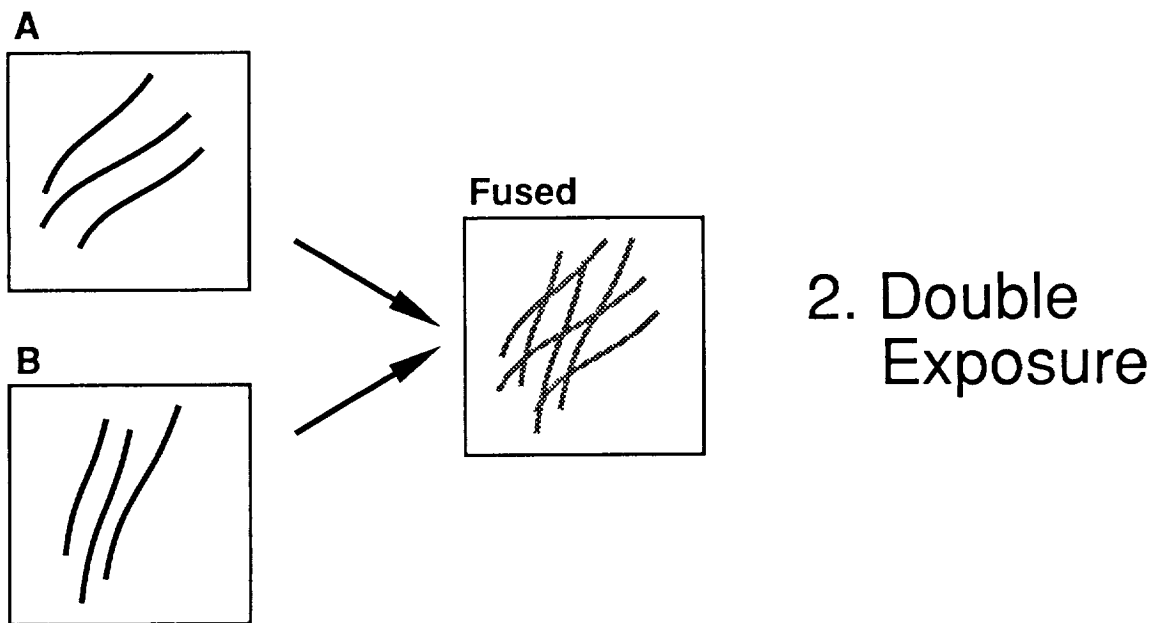

Pixel-Based Approach

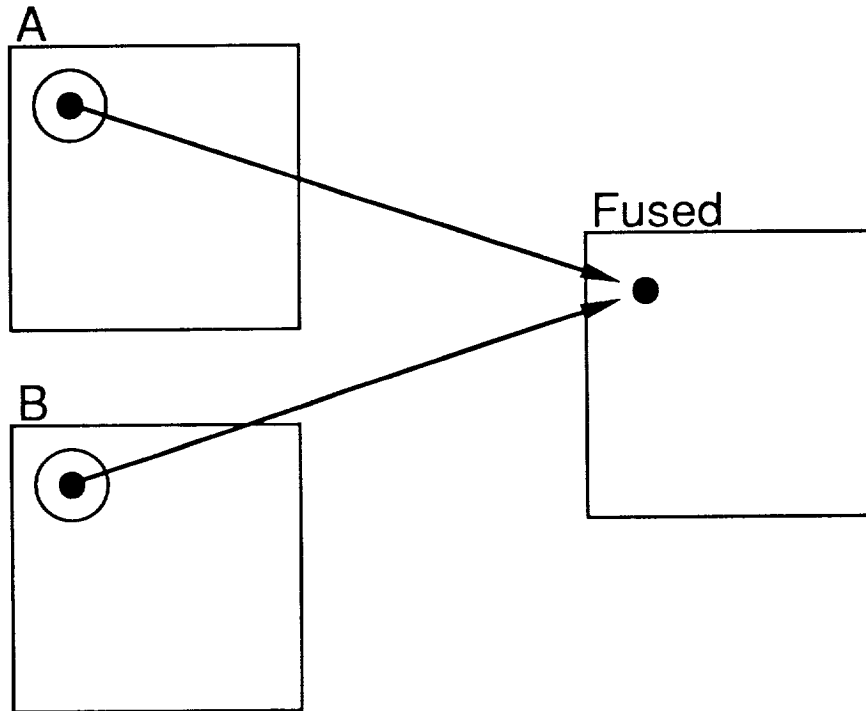

- each output pixel is computed separately
- based on the corresponding source image pixels
- or neighborhoods of corresponding pixels

Pattern-Selective Approach

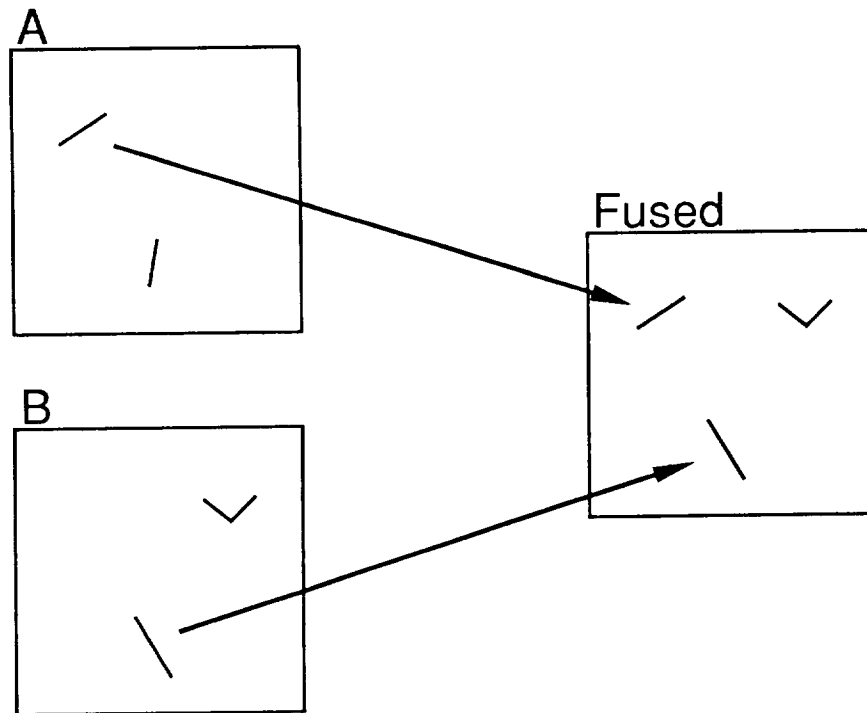

- copy a pattern at a time
- select most salient patterns only

Composite Imaging

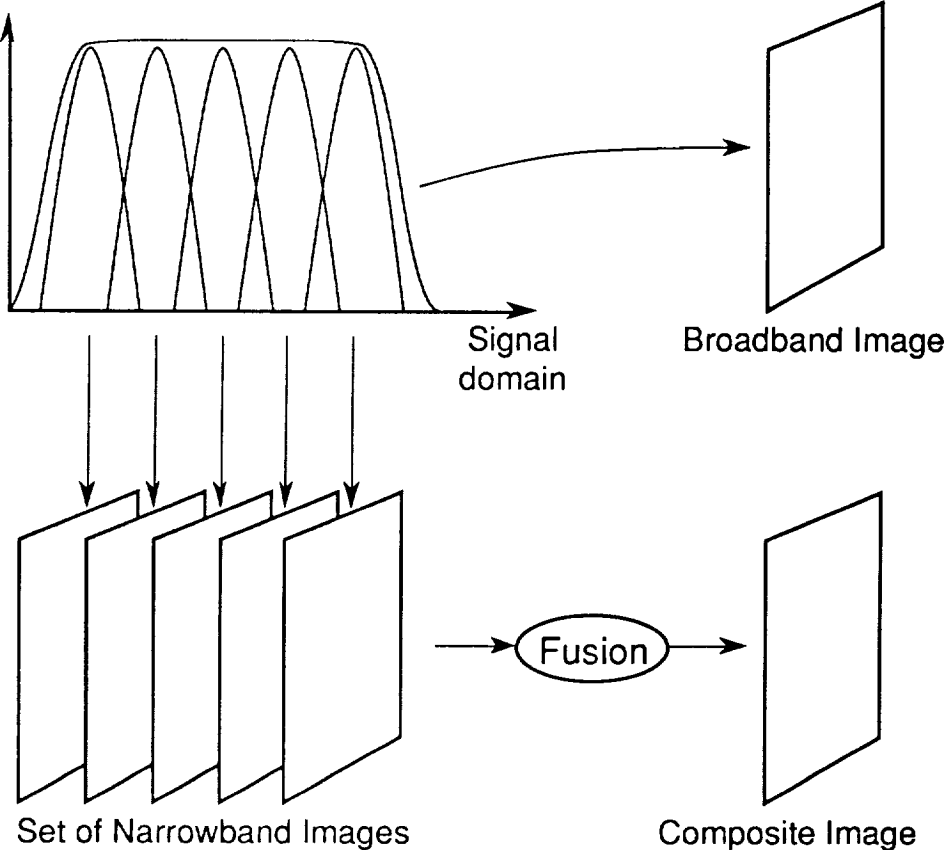

Pyramid-Based Fusion: Some History...

1983	Burt	model of human binocular vision
1984	Adelson	multi-focus
1990	Toet	IR and visual images
1991	Pavel,..	noise model
1992	Tinkler	TI method

Laplacian Pyramid Transform

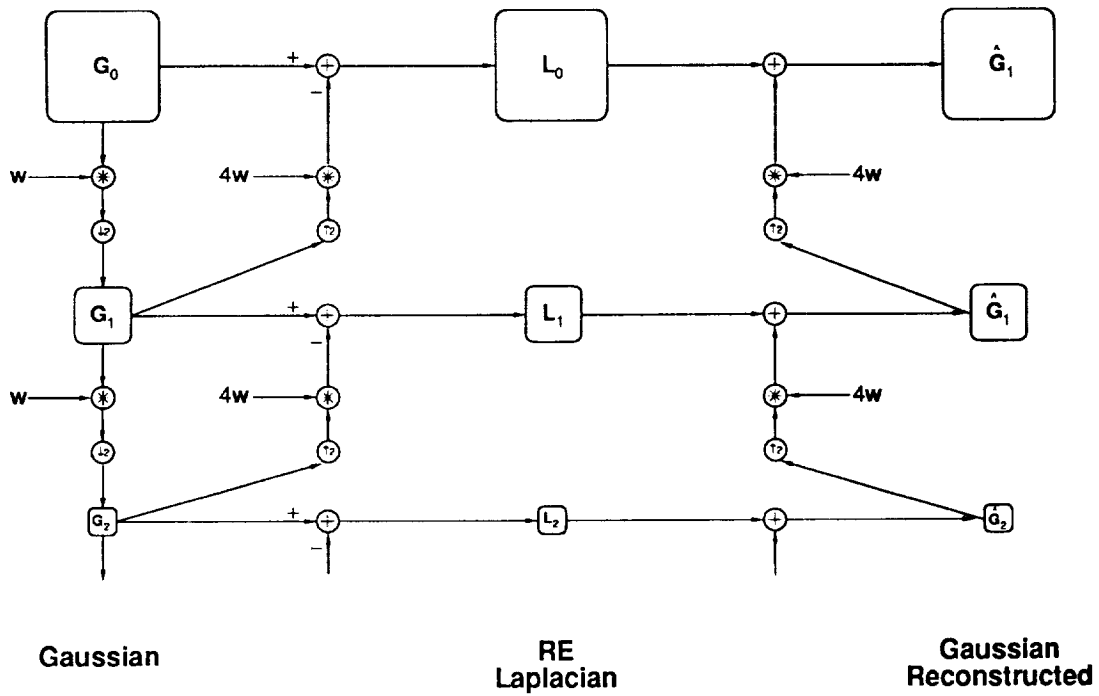

Gradient Pyramid Framework for Image Fusion

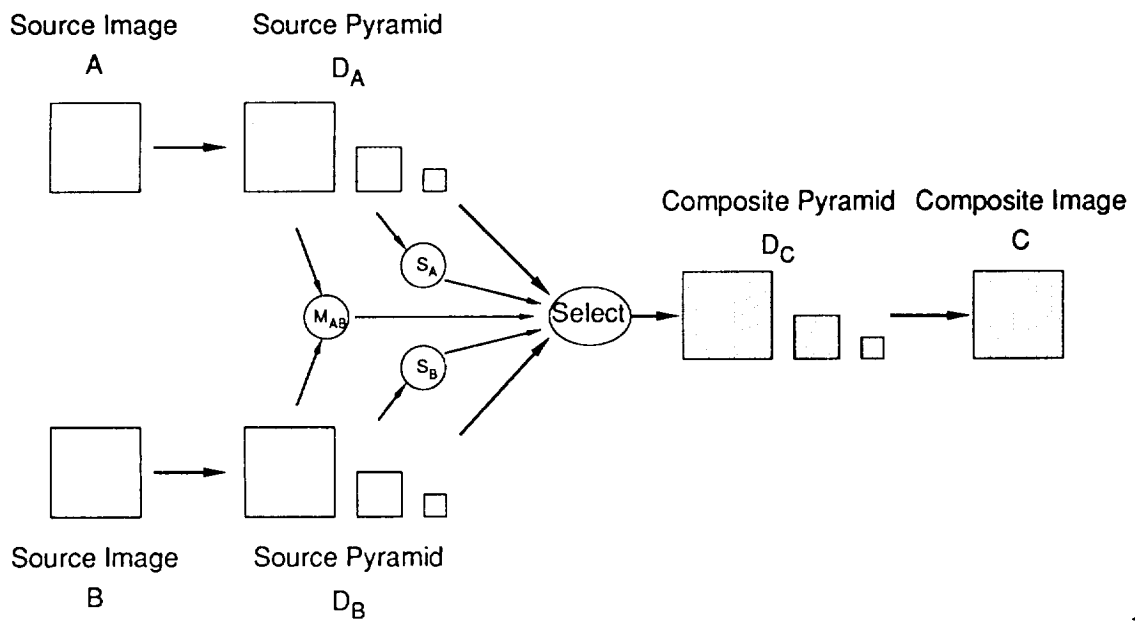

Composition Based on Scaled Relative Gradients

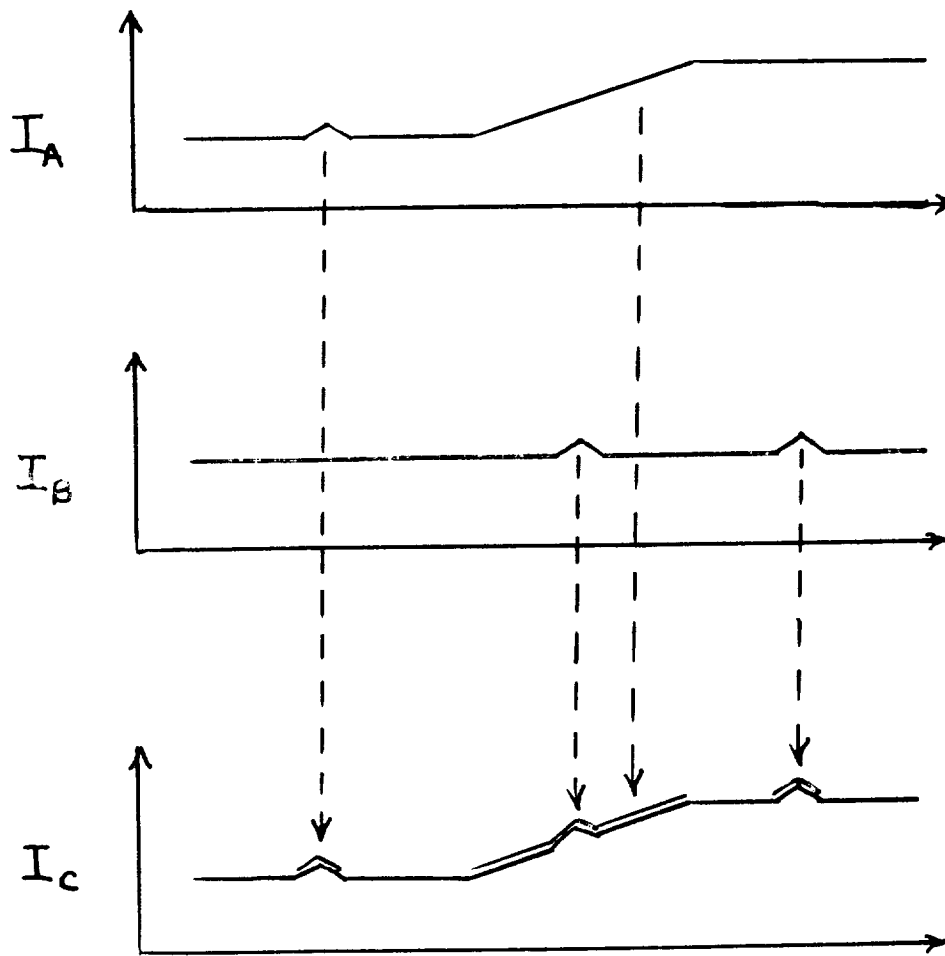

Scaled Gradient Operators

$$G(x, \sigma)$$



$$\frac{d}{dx} G$$



Gradient Pyramid Transform

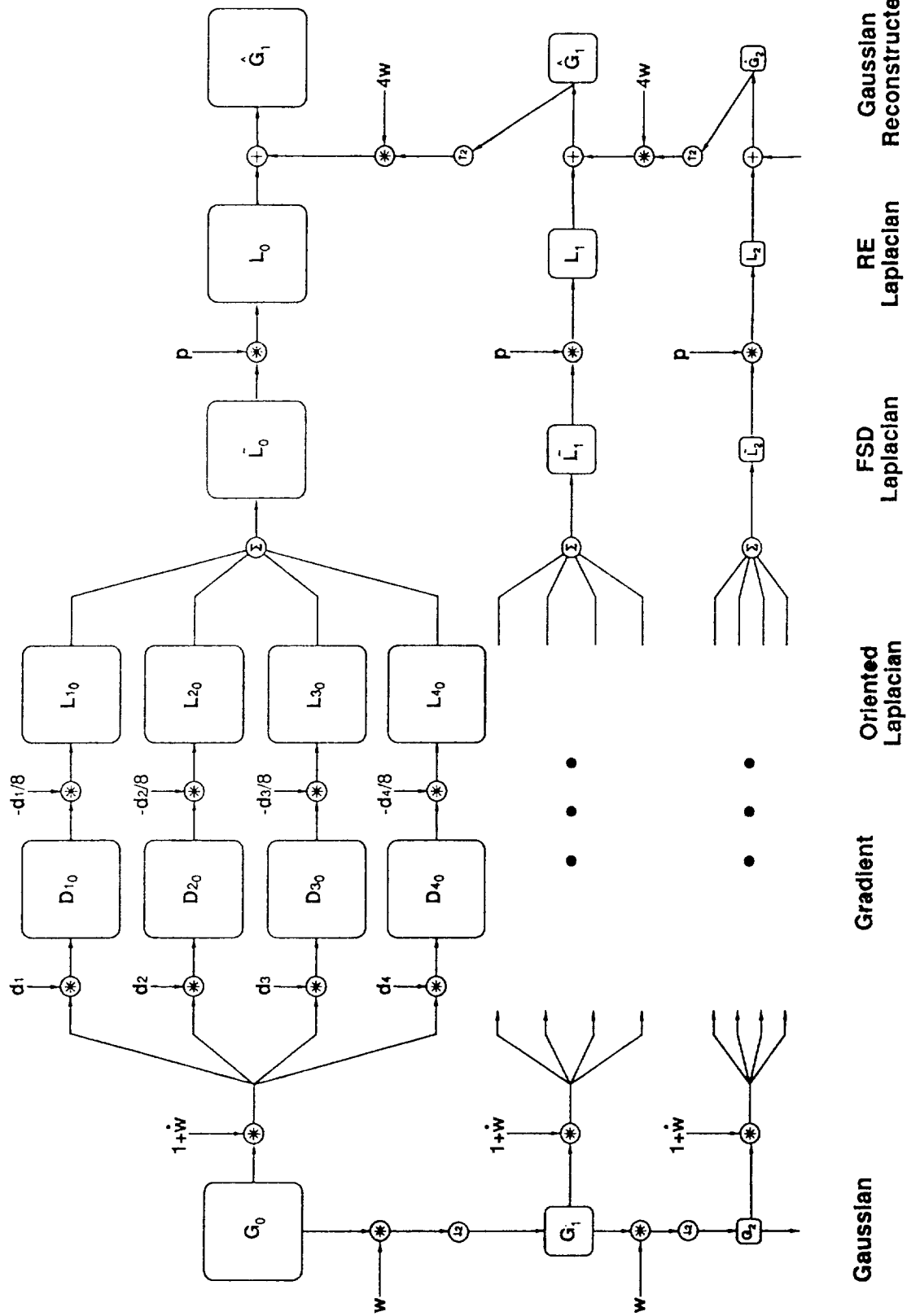



Multi-focus example of gradient pyramid fusion. (*a* and *b*) Source images obtained with a camera lens set to focus at different distances. (*c*) The fused image has an extended depth of field.



Multi-exposure example of gradient pyramid fusion. (*a* and *b*) Source images obtained with different camera exposure settings to observe patterns in shaded regions (*a*) and bright, sun-lit regions (*b*). (*c*) The fused image includes detail from both regions. (*d*) Pyramid samples values are normalized and quantized to just 4 bits to demonstrate that a broad dynamic range scene can be represented by a narrow dynamic range signal without loss of critical detail.

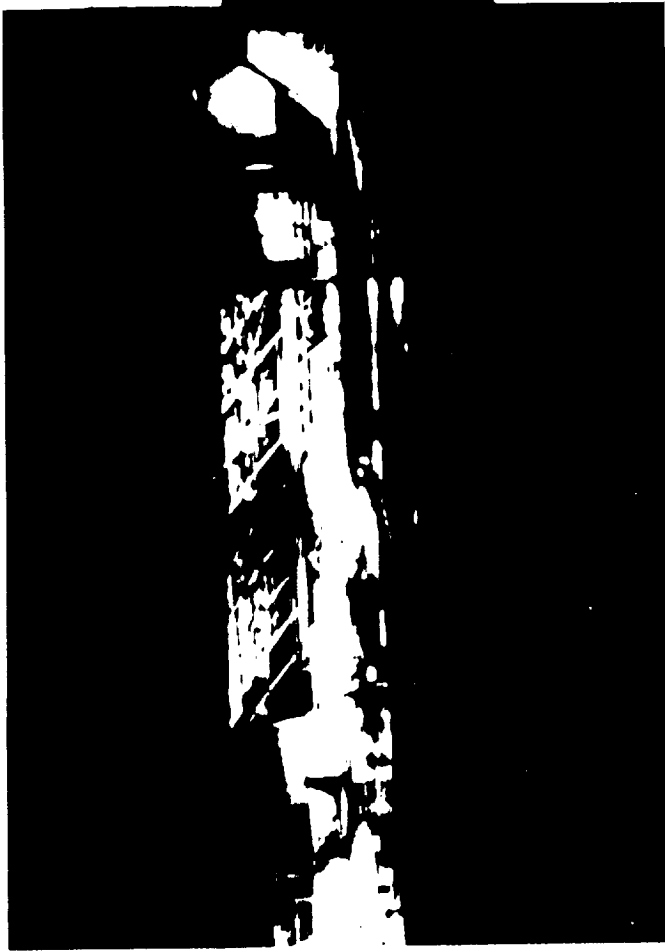

(a)



(b)



(c)

A multi-sensor example of gradient pyramid fusion. (a and b) Source images were obtained from a visible light camera (a) and an infrared camera (b). (c) The fused image includes details from both sources.

Summary

- **Enhance image capture by combining observations**
- **Combine to preserve contrast (max gradient)**
- **Gradient pyramid framework (multiscale)**
- **Deliberately limit each observation (narrow band)**