

**DESIGN STUDY TO SIMULATE THE DEVELOPMENT
OF A COMMERCIAL FREIGHT TRANSPORTATION SYSTEM**

**University of Notre Dame
Department of Aerospace and Mechanical Engineering
Notre Dame, Indiana**

**Dr. Stephen M. Batill
Kevin Costello and Jim Pinkelman, Teaching Assistants**

Abstract

The Notre Dame Aerospace Engineering senior class was divided into six design teams for the purpose of this study. A request for proposals (RFP) asking for the design of a remotely piloted vehicle (RPV) was given to the class, and each design team was responsible for designing, developing, producing, and presenting an RPV concept. The RFP called for the design of commercial freight transport RPV. The RFP provided a description of a fictitious world called 'Aeroworld'. Aeroworld's characteristics were scaled to provide the same types of challenges for RPV design that the real world market provides for the design of commercial aircraft. Fuel efficiency, range and payload capabilities, production and maintenance costs, and profitability are a few of the challenges that were addressed in this course. Each design team completed their project over the course of a semester by designing and flight testing a prototype, freight-carrying remotely piloted vehicle.

Introduction

The undergraduate Aerospace Engineering design project is presented to the senior class as a single semester course. The focus of this class is the "design process." The design process is the sequence of steps which an engineering group follows from the initiation of a project through to its completion. In this course it involves the definition of the mission, the determination of goals, the development of concepts, the selection and technical analysis of a concept, prototype production, and testing of the finished product. In the students' previous engineering courses, class projects typically focused on the solution of specific technical problems with little effort spent on the design process. The senior design class was created to augment the emphasis on engineering analysis by introducing the students to the design process.

The purpose of the design class is twofold. First, it serves as a capstone Aerospace Engineering course where the students have the opportunity to apply all of their knowledge from previous courses to a single, integrated project. Secondly, the class serves to bridge the gap between typical engineering coursework and engineering practice. This twofold purpose is fulfilled by structuring the course around the process of design, rather than the solution of an intricate technical problem.

The project for the 1992 design course was the development of a remotely piloted vehicle (RPV) to fulfill a commercial cargo carrying role. A model world called "Aeroworld" was created with its economic, geographic, and demographic characteristics tailored to provide similar design challenges for small remotely piloted vehicles that the real world provides for actual commercial cargo transport aircraft. The simple technologies involved in the design and construction of electric-powered RPVs allowed students with limited knowledge to experience the entire design process despite the time and resource limitations of a one semester undergraduate course. Using RPVs and the "Aeroworld" model allowed the students to address their design project from the very beginning of the design process all the way through to the production and flight testing of the actual product.

The following are some of the specific goals of the course:

- Introduce the student to system design methodology and, in particular, aircraft design.
- Illustrate the interactive interface between each of the technologies that influence the performance of a system.
- Provide an opportunity to integrate each of the independent technical disciplines at a level where the students understand the technology and can effectively use the appropriate tools.

- Develop an understanding of the planning, coordination, and communication necessary in a team project.
- Expose the students to numerous phases of the system development process, from problem definition to system operation.
- Provide the opportunity to experience the process of transitioning ideas to an actual product.

The course meets each of these goals by leading the students through a team-oriented, mission-directed, aircraft design project. The following section is the request for proposals which provided the students with a detailed description for the course project.

Request for Proposals - (RFP)

The mission and project requirements, as well as the Aeroworld model, were defined for the students in the request for proposals. This request placed some additional requirements and constraints on the basic mission specifications. In order to keep the project as open-ended as possible, the design teams were notified that certain aspects of the mission were open for modification, given sufficient justification for these changes.

Air Transport System Design

The successful development of an air transportation system depends upon a sound understanding of the market and efficient development of an aircraft system which can operate effectively in that market. Since a particular aircraft cannot satisfy every possible user need, it must be evaluated on how well it meets its own design objectives.

In order to be considered as a reasonable aircraft system for a commercial venture, it must be able to operate at a profit which requires compromises between technology and economics. The objective of this project will be to gain some insight into the problems and trade-offs involved in the design of a commercial transport system. This project will simulate numerous aspects of the overall systems design process so that you will be exposed to many of the conflicting requirements encountered in a systems design. In order to do so in the

limited time allowed for this single course, a "hypothetical world" has been developed and you will be provided with information on geography, demographics, and economic factors. The project is formulated in such a fashion that you will be asked to design a basic aircraft configuration which will have the greatest impact on a particular market. The project will not only allow you to perform a systems design study, but will provide an opportunity to identify those factors which have the most significant influence on the system design and design process. Formulating the project in this manner will also allow you the opportunity to fabricate the prototype for your aircraft and develop the experience of transitioning ideas to "hardware" and then validate the hardware with prototype flight testing.

An aircraft which is simply the fastest or "looks neat" will not be considered a marketable product. Economic feasibility and, in particular, compliance with the group's design objectives will provide the primary means for evaluating the system design of that group.

Opportunity

The project goal will be to design a commercial transport which will provide the greatest potential return on investment. Maximizing the profit that your airplane will make for an "overnight" package delivery network can be accomplished by minimizing the cost per "package." G-Dome Enterprises has conducted an extensive market survey for an airborne package delivery service and is now in the market for an aircraft which will allow them to operate at a maximum profit. AE441, INC. has agreed to work with them to establish a delivery system. This includes a market analysis, the establishment of a distribution concept and the development of a number of aircraft concepts to help meet this market need. This will be done by careful consideration and balancing of the variables such as the payload, range, fuel efficiency, production costs, as well as maintenance, operation and disposal costs. Appropriate data for each is included later in the project description.

The "world" market in which the airline will operate is shown in Figure 1. The service may operate in any number of markets provided that they use only one airplane design and any potential derivatives (your company does not have the engineering manpower to

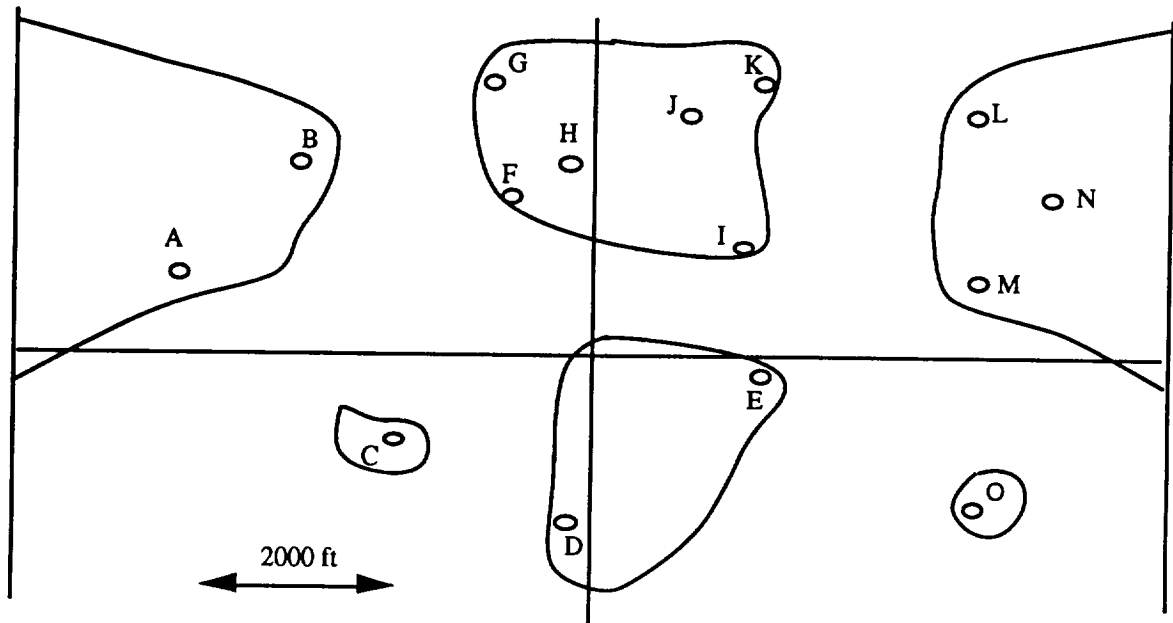

Fig. 1 Geography of "Aeroworld"

develop two different designs). Consider derivative aircraft as a possible cost-effective way of expanding the market.

Requirements

1. Develop a proposal for an aircraft and any appropriate derivative aircraft which will maximize the return on investment gained by the airline through careful consideration and balance of the payload/volume, the distance traveled, the fuel burned, and the production cost of each plane. The greatest measure of merit will be associated with obtaining the highest possible return on investment. You will be expected to determine the freight cost for all markets in which you intend to compete. The proposal should not only detail the design of the aircraft but must identify the most critical technical and economic factors associated with the design.

2. Develop a flying prototype for the system defined above. The prototype must be capable of demonstrating

the flight worthiness of the basic vehicle and flight control system and be capable of verifying the feasibility and profitability of the proposed airplane. The aerodynamic performance of the prototype will be evaluated using a "stick-fixed" catapult launch of the aircraft carrying a specialized instrument package and where the range of the aircraft under specified launch conditions will be the primary measure of aerodynamic efficiency. Flightworthiness and handling qualities of the prototype will be demonstrated by flying a closed figure "8" course within a highly constrained envelope.

Basic Information for "Aeroworld"

The following information is to be used to define special technical and economic factors for this project. Some information is specific, other information provides ranges which are projected to exist during the development of this airplane.

1. Payload: There are two standard parcel packing

containers, a 2"cube and a 4"cube. Remember these are cargo, therefore items like access and ease in loading are important. Since various types of cargo can be considered, cargo weight/volume requirements are also important. Cargo weights can vary from 0.01 to 0.04 oz/cubic inch.

2. Range: distance traveled in feet.
3. Fuel: battery charge measured in milli-amp hours.
4. Production cost = 400 x (total cost of prototype in dollars) \$ + 1000 x (prototype construction man-hours) \$.
5. Operation costs = (number of servos in the aircraft) x flight time in minutes - this is a cost per flight.
6. Maintenance costs = \$50 per man-minute for a complete "battery" exchange - this is a cost per flight.
7. Fuel costs = \$5.00 to \$20.00 per milli-amp hour.
8. Regulations will not allow your plane to produce excessive "noise" from sonic-booms; consider the speed of sound in this "world" to be 30 ft/s.
9. The typical runway length at the city airports is 75 ft, this length is scaled by a runway factor in certain cities.
10. Time scale: "Aeroworld day" is 30 minutes.
11. Propulsion systems: The design, and derivatives, should use one or a number of electric propulsion systems from a family of motors currently available.
12. Handling qualities: To be able to perform a sustained, level 60' radius turn.
13. Loiter capabilities: The aircraft must be able to fly to the closest alternate airport and maintain a loiter for one minute.
14. Aircraft Life: Is based upon a scaled fatigue life of the materials used in Aeroworld.

Special Considerations for the Technology Demonstrator

The prototype system will be an RPV and shall satisfy the following:

1. All basic operation will be line-of-sight with a fixed ground-based pilot, although automatic control or other systems can be considered.
2. The aircraft must be able to take off from the ground and land on the ground under its own power.
3. The prototype flight tests for the Technology Demonstrator will be conducted on a closed course in the Loftus Center. The altitude must not exceed 25' at any point on the course.
4. Catapult launch tests will be conducted in the Loftus Center. Details on the catapult and instrument package will be provided.
5. The complete aircraft must be able to be disassembled for transportation and storage and must fit within a storage container no larger than 2' x 2' x 5'.
6. Safety considerations for systems operations are critical. A complete safety assessment for the system is required.
7. The Technology Demonstrator will be a full-sized prototype of the actual design and must be used to validate the most critical range/payload condition for the aircraft.
8. Take-off must be accomplished within the take-off region of 75 ft.
9. A complete record of prototype production cost (materials and manhours) is required.
10. The radio control system and the instrumentation package must be removable, and a complete system installation should be able to be accomplished in 30 min.
11. System control for the flight demonstrator will be a Futaba 6FG radio system with up to 4 S28 servos or a system of comparable weight and size.

12. Each group must comply with all FAA and FCC regulations for operation of remotely piloted vehicles and others imposed by the course instructor.

Student Response to RFP

Each of the six student design teams responded to the RFP by defining mission priorities for their design within the framework provided by the RFP. The groups established Design Requirements and Objectives (DR&O) for their RPVs according to the mission priorities that they set for themselves. The DR&Os consisted of target performance goals such as payload and range requirements as well as configurational data dealing with the RPV's manufacturing and operating requirements. With these goals established, the members in each group created specific RPV concepts to satisfy the mission. From these individual concepts, each group selected one for their team concept. The team concept was developed throughout the course up to the actual construction and flight testing of a prototype. The following section describes the six group concepts.

Concept Descriptions

The following summaries provide an overview of each of the six team concepts. These summaries describe the final concept and address specific technical merits and limitations of each group's RPV. It is interesting to note that each of the six groups created different designs although they were all given the same request for proposals.

The following are edited versions of the final proposal executive summaries. Further technical detail on each proposal is available upon request.

S.T.o.R.M.

The members of Team Asylum have proposed a helicopter design concept, called the S.T.o.R.M., in order to meet the market demands for an aircraft to perform overnight package delivery services in Aeroworld. Many critical design areas needed to be investigated as part of the helicopter concept's selection.

One of the most significant design factors was the weight of the aircraft. This determined the selection of the propulsion system necessary to get the S.T.o.R.M. off the ground, and maintain flight once airborne. After an analysis of helicopter flight principles, it became apparent that if the S.T.o.R.M. could be provided with the necessary power to hover, it would also be able to sustain forward flight at a cruise velocity of 25 ft/sec. This is due to the fact that a helicopter requires more power to hover than to maintain forward flight. Using the provided data bases along with researched weight estimates, the S.T.o.R.M. was determined to weigh within the range of 4.77 lbs and 7.33 lbs, depending upon the weight of the payload being transported. In an attempt to fulfill the mission requirement mandating delivery of the .04 oz/cu in cargo, a propulsion system which enabled the S.T.o.R.M. to carry 2.56 lbs of cargo within a 1024 cu in payload bay would be required. An Astro 25 motor was selected because of its ability to deliver the necessary power required, while minimizing the battery-package and motor weights.

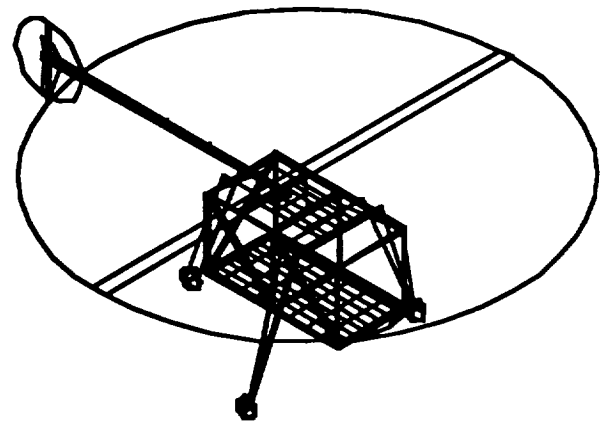

Fig. 2 The S.T.o.R.M.

Another significant factor closely related with the motor selection was the choice of the main rotor. Since the main rotor is the primary source of lift for the helicopter, its proper selection became increasingly important. The rotor diameter needed to be large enough to provide the necessary lift within the bounds of the power available limits of the Astro 25 motor, yet not be so large that it would suffer severe drooping at the rotor tips or be in

danger of clipping the tail rotor during rotation. A main rotor diameter of 50 inches was chosen in order to best fulfill these constraints.

Upon first analysis, a helicopter concept provides many advantages for the required mission. The S.T.o.R.M.'s ability to eliminate takeoff distance, landing distance, and loiter time constraints due to its vertical takeoff and landing capabilities was viewed as a major advantage in time and fuel savings. The S.T.o.R.M.'s ability to fly at slow speeds and thus stay under the Aeroworld sound barrier of 30 ft/sec was also a desirable design aspect. Also, the S.T.o.R.M.'s maneuverability would enable it to avoid obstacles better than a conventional airplane design.

However, some disadvantages for this concept exist as well. The excessive weight of S.T.o.R.M.'s design along with the tremendous power requirements necessary for its flight hinder the helicopter's range and endurance capabilities. Thus, it became necessary to decrease the market that could be served. Instead of servicing all of Aeroworld, only the central continent could be serviced for the concept to remain economically feasible. The cost associated with the technological complexity of the S.T.o.R.M.'s development became a hindrance. Although the smaller market (the central continent) would provide an estimated 48% profit based on the original investment, it seems that the helicopter concept falls somewhat short of the objective to fulfill all of the mission requirements. However, the evaluation of a radical vehicle system was bold, exciting, and innovative and should provide future design studies with the valuable information necessary to successfully complete other missions.

The final design characteristics of the S.T.o.R.M. incorporated an Astro 25 motor, powered by 14 Panasonic 140SCRC batteries, thus allowing the helicopter to fly at a cruise velocity of 25 ft/sec. With a payload volume of 1024 cubic inches and a full payload of 2.56 lbs., the S.T.o.R.M. would require 255 watts of power to hover and 237 watts of power to fly at cruise velocity. The lift for the aircraft is provided by a Clark-Y 50-inch diameter main rotor, which in turn is stabilized by an 8-inch diameter, symmetric tail rotor. An overall length of 31 inches, a height of 16 inches, a fuselage width of 8.25 inches, and a landing gear base width of 20 inches round out the critical dimensions for the S.T.o.R.M., thus making it compact enough to fit in the 2' x 2' x 5' storage container area. The helicopter has an empty weight of

4.77 lbs and a full-cargo weight of 7.33 lbs, with a maximum range capability of 5875 feet. The S.T.o.R.M., despite its technological complexities, was an invaluable source of new technical information.

Jeff

Jeff is a remotely piloted vehicle concept developed to fulfill the mission proposed by G-Dome Enterprises: to build a cost efficient aircraft to service Aeroworld with overnight cargo delivery. The design of Jeff was most significantly influenced by the need to minimize costs. This objective was pursued by building fewer large planes as opposed to many small planes. Thus, by building an aircraft with a large payload capacity, G-Dome Enterprises will be able to minimize the high costs and the large number of cycles that are associated with a large fleet. Another factor which had a significant influence on our design was the constraint that the RPV fit into a 2' x 2' x 5' storage container. This constraint meant that Jeff's wing span would be limited to 10 feet unless we wanted to build foldable wings. To avoid this and to provide enough lifting surface to suit our needs a canard configuration was chosen.

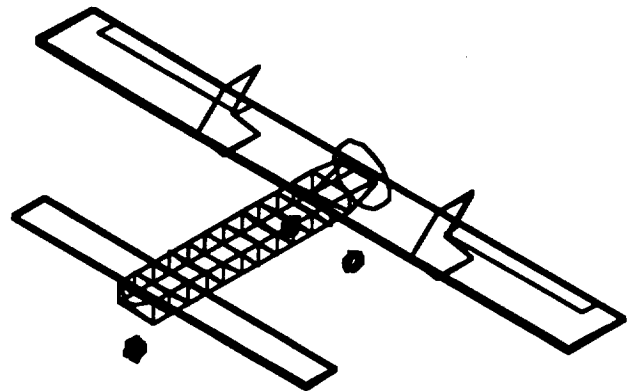

Fig. 3 Jeff

Because of the canard configuration, stability of the aircraft became a main design concern. To achieve acceptable static margins, the interior of the aircraft was carefully configured and wing and canard carefully sized and placed. The aircraft achieves good static margins (10-20%) at full payload and also at a decreased payload with the addition of ballast. Control surfaces were sized

accordingly. Ground control is achieved with a movable nose wheel, and elevons on the main wing provide pitch and roll control.

Economically, the aircraft is very cost efficient. A fleet of 19 aircraft is sufficient to service our target market--the upper hemisphere of Aeroworld. The lower hemisphere of Aeroworld was left out because it was thought that the long distances between cities in this hemisphere outweighed the benefits of the limited cargo that existed in this market. At \$287,000 per plane, fleet life cost is \$33,800,000. This figure translates to a unit volume cost of \$3.72/in³ of cargo. Thus G-Dome Enterprises can charge a competitive price of approximately \$4/in³ and maintain a profit of \$12,261,388 per year.

Some areas of concern still remain. Static stability, although achieved, was a difficult issue. The stability depends largely on payload weight and payload distribution within the fuselage because the center of gravity of the plane when empty differs greatly from that when full. Also, propeller ground clearance may be a concern as the plane rotates on takeoff. Finally, because the aircraft is so large and because the airfoil chosen has a sharp trailing edge, the manufacturing process was somewhat time-consuming and difficult.

The aircraft was designed to fly at a maximum altitude of 25 ft and at low speeds (less than 30 ft/sec). To carry large amounts of payload, Jeff consists primarily of a 1408 in³ fuselage (44" x 8" x 4"). A rear-mounted pusher propeller was chosen. The FX63-137B airfoil was selected for both the wing and canard because of its high lift characteristics and moderate thickness. Both lifting surfaces are rectangular, with aspect ratios of 10. Sized to provide static stability as well as lift, the wing planform area is 10.0 ft²; canard planform area is 3.0 ft². Each of the two vertical stabilizers have an area of 0.75 ft² and is mounted above and below the wing 3 ft inboard from the wing tips.

The aircraft is constructed mainly of balsa, with spruce wing and canard spars and a monokote covering. It was designed to support a maximum payload weight of 35 oz (total aircraft weight of 108 oz) and withstand a maximum load factor of 2.5. Tricycle landing gear support the plane up to a load factor of 4.0 during landing, and ensure propeller clearance during takeoff rotation.

The propulsion system consists of an Astro 15 motor, which was chosen because it can provide the power required for our large aircraft to take off and fly at a cruise velocity of 28 ft/sec. Twelve 1.2 volt batteries are required to power the system and to ensure takeoff in a distance of 60 ft, a maximum range of 9770 ft, and a maximum endurance of 11.50 minutes.

Despite the technical challenges, Jeff provides the Aeroworld market with a large cargo carrying capacity which will ensure that all cargo can be delivered to its target cities efficiently overnight. It provides G-Dome Enterprises with a low-cost small fleet of aircraft that will operate at a profit over the life span of the structure, and it can fully accomplish the specified mission.

Hermes CX-7

The Hermes CX-7 has been designed to service the overnight parcel package delivery needs of the cities of Aeroworld as determined in the G-Dome Enterprises market survey. The design optimization centers on the prime goal of servicing the needs of these cities as efficiently and profitably as possible. The greatest factors which affect the design of an aircraft for the mission outlined in the RFP are cost, construction feasibility, and effectiveness of the design. Other influencing factors are given by the constraints of the market, including a maximum take-off and landing distance of 60 feet, storage capability in a container of size 5' x 3' x 2', cargo packages of 2 and 4 in cubes, and ability to turn with a radius no larger than 60 feet. Safety considerations, such as flying at or below Mach one (30 ft/sec), controllability, and maintainability must also be designed into the aircraft. Another influential factor is the efficiency of the aircraft as a system involving optimizations and tradeoffs of such factors as weight, lifting surface sizing, structural redundancy, and material costs.

The design market will consist of all Aeroworld cities except C, D, E, and O due to low demand in these cities and their excessive distances from the northern cities. A routing system was designed to service the needs of the target cities overnight using a fleet of 22 planes. The routing system is based on two main hubs at cities F and K. Each aircraft will make two round-trips on one leg of the route. To minimize cost, the route structure is designed such that it uses as few aircraft as possible, and

these aircraft cover the shortest distance possible each night.

The constraint which sized the engine and propeller was take-off performance. The Hermes CX-7 employs the Astro 15 engine and the TopFlight 12x6 propeller. This engine/propeller combination provides the necessary power needed for take-off in less than 60 feet, while minimizing the fuel burned during cruise. The Astro 15 was the engine that weighed the least of those which provided sufficient power for take-off. The TopFlight 12x6 was the smallest diameter propeller which fulfilled the necessary take-off distance requirement. The TopFlight version of this propeller was chosen because it exhibits the best efficiency of the brands available. The aircraft will be powered by 12 Panasonic 600 milli-amp hour batteries having voltage capacity of 1.2 volts each. These provide sufficient power for both takeoff and cruise conditions to meet the restrictions on take-off distance and on range needed.

The wing section will be constructed from the NACA 6412 airfoil. This airfoil section was chosen because it provides the desired lift capability while also minimizing the difficulty in construction because of its simple structure. The wing has an area of 8 square feet and an aspect ratio of 12. There is no sweep or taper on the wings because this will greatly simplify construction. The wings will be mounted as two plug-in sections, low on the fuselage at a dihedral of 6 degrees and an angle of incidence of 1 degree. The wing will have three spars and will be built primarily from spruce, bass, balsa, and monokote.

The fuselage will have a rectangular cross-section of area 4.6 in x 6.9 in and a length of 54 in. It is constructed of spruce and balsa wood and includes a cargo space 4 in x 4 in x 40 in. The aircraft was laid out such that the center of gravity is located 24 in from the front of the fuselage regardless of whether the aircraft is empty or full of cargo.

The Hermes CX-7 is designed to be controlled with rudder and elevator deflections. There are no ailerons. This minimizes the number of servos needed to control the aircraft. Turning is achieved through the use of the rudder and dihedral effects. The horizontal and vertical surfaces of the tail both consist of flat plates for simplicity. The elevator area is 30% of the horizontal tail and the

rudder area is 50% of the vertical tail. The c.g. travel is constrained by static and dynamic stability considerations and is limited to 10% forward and 5% aft of the design c.g. position (24 inches from the front of the fuselage).

The Hermes CX-7 will meet and surpass the performance requirement of the mission and market. The take-off distance is 32 feet, and the landing distance is 47 feet, well below the constraint of 60 feet. The design range is 10,655 feet, and endurance is 355 seconds. The maximum range is also 10,655 feet; maximum endurance is 356 seconds. The aircraft can execute a 48-foot radius turn, which is less than the 60-foot restriction, at a 30-degree bank angle.

The Hermes CX-7 will cost an estimated \$390,000 (in Aeroworld dollars). The recommended charge is \$10.50 per cubic inch for an average delivery distance. This will enable G-Dome Enterprises to break even in less than half of the life of the aircraft.

Arrow 227

The Arrow 227 is a commercial transport designed for use in an overnight package delivery network. The major goal of the concept was to provide the delivery service with the greatest potential return on investment.

The first step in the design process was to conduct a detailed mission evaluation followed by a thorough market analysis. The market analysis of Aeroworld led to the implementation of a hub system of delivery with the hub located at city K. The analysis also revealed that service to cities C, D, and O should be excluded due to small runways and a negative profit margin due to excessive fuel costs. In order to execute this delivery plan, the Arrow 227 will be required to fly intercontinental flights with a minimum range of 9720 feet and a minimum endurance of 6 minutes. The flight route suggested by the producers of the Arrow 227 requires a fleet of 16 aircraft. The fleet services twelve cities in Aeroworld, and each craft carries a maximum volume load of 1000 in³ to each city. This proposed service also requires the Arrow 227 to take off within a distance of 60 feet due to restrictions at Aeroworld's city B airport. Finally, the RFP also required a minimum turn radius of 60 ft and a packaging constraint of 5' x 2' x 2'.

The design objectives of the Arrow 227 were based on three parameters: production cost, payload weight, and aerodynamic efficiency. Low production cost helps to reduce initial investment. Increased payload weight allows for a decrease in flight cycles and, therefore, less fuel consumption than an aircraft carrying less payload weight and requiring more flight cycles. In addition, fewer flight cycles will allow a fleet to last longer. Finally, increased aerodynamic efficiency in the form of high L/D will decrease fuel consumption.

The aerodynamics of the design were driven mainly by the desire for the minimization of drag and production cost. The wing planform was designed to minimize induced drag through the use of an aspect ratio equal to 10.5. A rectangular configuration was implemented to reduce production cost. The GO-508 airfoil was selected on the basis that it enabled cruise at the minimum point of the airfoil drag curve, and its simple shape helped to reduce production cost. Drag minimization was also apparent in the component drag breakdown. The fuselage and landing gear were designed to minimize their contribution to total parasite drag of the aircraft.

The design of the propulsion system was driven by three main objectives: 60-ft take-off distance, minimal weight, and minimal current draw. The Astro 15 engine was chosen because it provided enough power to allow the aircraft to take off under 60 feet. The Zinger 10-6 was chosen as the propeller because it performed close to its maximum efficiency at cruise, and it provided enough thrust to take off within 60 feet. Twelve 1.2 volt, 900 milliamp-hour batteries were used to provide enough power for the engine during takeoff and enough endurance for cruise.

The Arrow 227 is stabilized by employing a horizontal tail, a vertical tail, and dihedral. A conventional wing/tail configuration was chosen for the Arrow 227 so the stability of the aircraft would be less sensitive to the center of gravity shift that occurs in cargo transport aircraft. The wing location and the center of gravity location of the loaded aircraft were positioned so that no trim drag occurred at the cruise conditions. Such placement maximized the aerodynamic efficiency. Longitudinal and lateral control are achieved through the use of an elevator and a rudder. Ailerons were not employed since they would introduce additional cost and weight. Instead, lateral control was obtained by coupling

the yaw and roll axis by using a high wing with 8 degrees of dihedral.

Because the structure of the aircraft is the major weight component, it must be light in order to meet our weight objective. With this in mind, the fuselage was designed as an all-balsa wood, truss structure with all unnecessary support beams eliminated. The Arrow 227 is a cargo plane flying at low velocities. Since it is not expected to fly high g-maneuvers, the limit load factor is only 1.5. This allowed the wing and fuselage to be designed as light as possible, resulting in a structural weight fraction of less than 30%.

The strengths of the Arrow 227 are:

- large payload volume
- low weight
- large payload fraction
- simple design.

The aircraft design was based on a 1000 in³ cargo hold. The desire for a maximum cargo hold was to decrease the number of flights and increase profit for G-Dome Enterprises. The 1000 in³ cargo hold can carry maximum capacity at an average package weight of .032 ounce per in³. The total aircraft weight of 6.0 lbs loaded was due to material selection, lightweight design of the fuselage and wing, and careful construction. By excluding control surfaces on the wing and implementing dihedral, added weight due to hinges and control rods was eliminated.

The weaknesses of the Arrow 227 are:

- inability to service all of Aeroworld
- low take-off thrust from small propeller.

The aircraft was designed to have a maximum full weight of 6.0 lbs carrying 1000 in³ of cargo. However, this payload volume and projected range and endurance do not allow all of Aeroworld to be serviced. The cargo volume carried to and from each of the three cities eliminated from service was not sufficient to provide a profit for G-Dome Enterprises, and these cities do not have sufficient runway lengths to accommodate the Arrow 227.

The Zinger 10-6 was chosen as the propeller for the Arrow 227. The propeller was designed to provide enough thrust at take-off, but there were two factors that led to uncertainty in these findings. The first was the high

friction coefficient, 0.15, of the flight test range, which would increase the take-off thrust requirement. The second was the size of the fuselage. The fuselage cross section was 7.5 x 4.0 in. Considering the diameter of the propeller was only 10 inches, the effect of fuselage interference on the propeller was uncertain.

Exodus Prime Mover

The Exodus Prime Mover (Figure 4) is an overnight package delivery aircraft designed to serve the Northern Hemisphere of Aeroworld. The preliminary design goals originated from the desire to produce a large profit. The two main driving forces throughout the design process were, first, to reduce the construction man-hours by simplifying the aircraft design, thereby decreasing the total production cost of the aircraft. The second influential factor affecting the design was minimizing the fuel cost during cruise. The lowest fuel consumption occurs at a cruise velocity of 30 ft/s. Overall, it was necessary to balance the economic benefits with the performance characteristics in order to create a profitable

product that meets all specified requirements and objectives.

The SPICA airfoil section and a rectangular planform were selected to reduce construction hours necessary to produce the wing. Its flat bottom and lift characteristics provide a balance between aircraft performance and construction simplicity. The wing area of 9.62 square feet ensured the necessary lift both during cruise and takeoff. In addition, cruise conditions occur at maximum lift to drag ratio.

The Astro 15 electric motor and the ZingerJ 11-5 propeller comprise the propulsion system of the Prime Mover. The propeller selection was based upon the take-off distance requirement of 60 feet; the ZingerJ 11-5 provided the highest efficiency while still meeting this requirement. Twelve batteries of 1.2 volts and 1000 mah each were selected to power the system. The battery pack provides the voltage needed for take-off and the capacity required for the flight time of the aircraft.

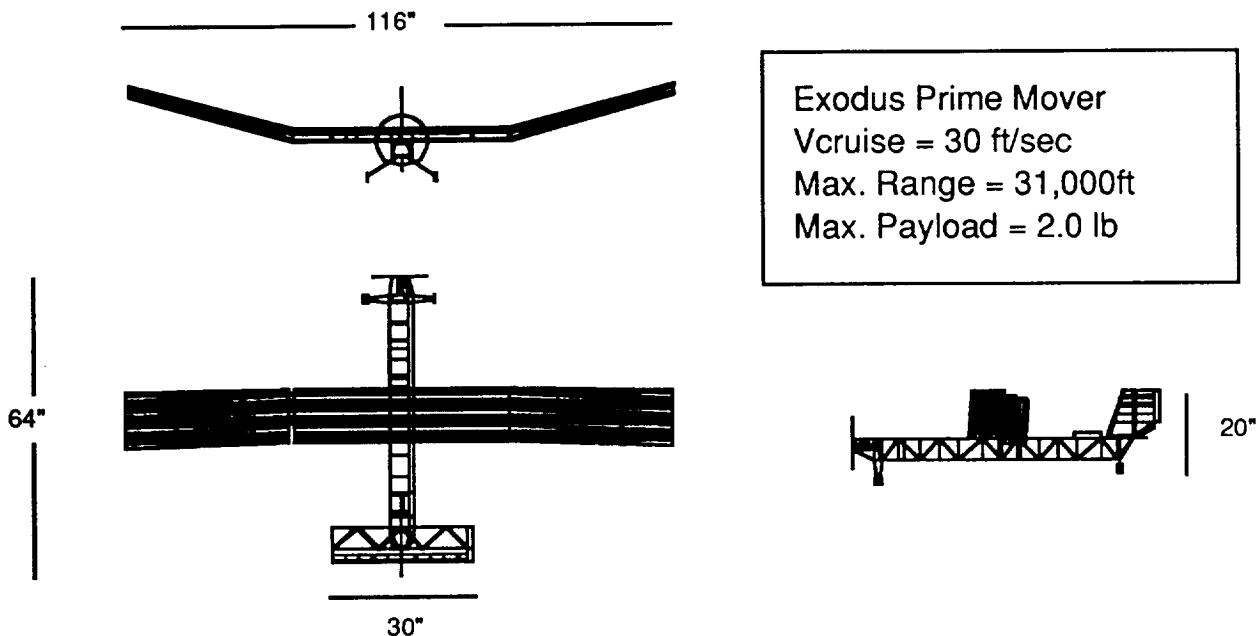

Fig. 4 Exodus Prime Mover

Directional and longitudinal control have been achieved through the use of a rudder and an elevator. A polyhedral concept has also been adopted for roll control. The polyhedral was chosen over the dihedral to decrease the amount of structure needed to withstand the bending moment at the root of the wing.

The Prime Mover is capable of guaranteeing overnight delivery for the entire Northern Hemisphere due to the proposed fleet size of 42 airplanes and the high range and endurance capabilities. The design objectives required the aircraft to meet a 8600 foot range minimum. The final design has displayed a cruise range of 24,000 feet, enabling the aircraft to complete its nightly schedule without the need to refuel. This reduces the operating costs of the aircraft. The maximum range and endurance of the fully loaded aircraft is 31,000 feet and 13.5 minutes, respectively. The take-off distance at maximum take-off weight is 59 feet.

The Prime Mover has a rectangular frontal area of 4.6 inches by 4.4 inches and a fuselage length just under 5.0 feet to provide 800 cubic inches of cargo space. The fuselage, wing, and empennage were designed to withstand a landing load factor of 4.0, a cruise load factor of 2.5, and a catapult launch load factor of 2.0.

The wing and the empennage will be removable in order to fit the disassembled aircraft within a 2 ft x 2 ft x 5 ft box. Although this design increases the complexity of the structure, it enables the use of a modular construction technique. Each component of the aircraft may be built separately and assembled at a later time. This construction method will decrease the construction man-hours.

As a result of the previously mentioned design characteristics, Exodus confidently presents the Prime Mover, an aircraft created to harmonize technical and economic considerations. The total production cost is estimated at \$376,000. Based upon the production, operating, maintenance, and fuel costs Exodus recommends the price per cubic inch for intracontinental and overseas shipping be \$8.74 and \$11.01, respectively, in order to break even on the original investment.

Reliant

In formulating the Reliant design, the driving philosophy was not just to fulfill the mission requirements, but to do so in a creative manner. This explains the unconventional aircraft design, named the F-92 Reliant. Although unconventional, and perhaps more expensive to produce, the design has distinct advantages which could only be attained through such a creative design.

Major components of the F-92 Reliant include:

- unobstructed cargo bay, 1024 in³ capability
- loading ramp
- dual wing configuration
- polyhedral wing configuration

These design components combined to create an aircraft that would most effectively meet the goals of cargo transportation in Aeroworld at minimum cost.

The unobstructed cargo bay and rear loading ramp allow for ease of cargo loading and unloading. These concepts were born at the initiation of the design; the rest of the aircraft developed around the fuselage cargo bay. It is not surprising that the aircraft design started here, since the main purpose of the Reliant is to transport cargo.

The volume cargo capacity of 1024 in³ was established as the desired capacity based on an extensive market survey of Aeroworld. This large volume allows for a reduced number of flights required per day, yet still avoids flights with large amounts of unused cargo space. This component of the design is based on the reasoning that reducing the number of flights reduces fuel costs and also increases aircraft longevity.

The large horizontal tail and elevator allow for a large range of center of gravity locations; this allows for flexibility in cargo loading. This feature, in combination with the open cargo bay, reduces time and costs associated with cargo balancing and planning.

To effectively utilize the large volume capacity, the Reliant also must be capable of the large weight associated with the volume. To ensure that the Reliant is capable of carrying cargo and its own structural weight, a large lifting surface was designed for the aircraft. It was determined that for a single wing, the necessary 13 ft² of

wing area would be very difficult to build. The dual wing configuration permits 13 ft² of lifting surface while avoiding the structural complication and weight penalties of a single large wing. The placement of the wings with respect to each other maximizes aerodynamic performance without violating stability and control requirements.

The polyhedral design of the upper wing, combined with

a large rudder, allows for roll control of the Reliant without ailerons. This decision was based on the assumption that fixed polyhedral joints are less complex to incorporate into the plane than control-dependent ailerons, especially when considering that the wing must be segmented anyway because of packaging constraints. Furthermore, the polyhedral option, unlike ailerons, avoids the extra costs of an additional servo.

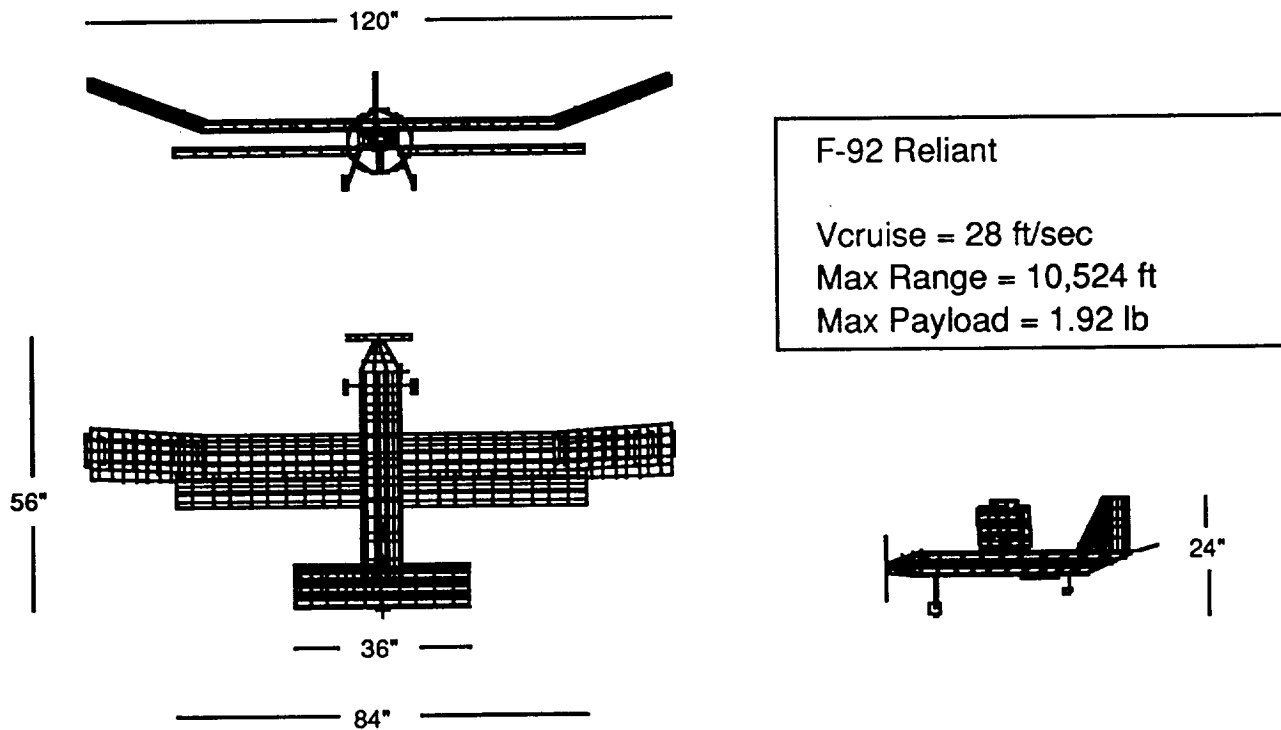

Fig. 5 Reliant

Thus, the unique design of the Reliant grew from the most basic goal of providing a highly cost-effective, reliable means of cargo transportation. On this foundation, with the help of a team of seven engineers, the Reliant evolved to its present configuration. General information about the Reliant is presented below.

The empty weight of the aircraft is 5.5 lbs and the maximum take-off weight is 7.5 lbs. The range of the aircraft with full cargo load is 8100 feet. The propulsion system includes a Cobalt-15 motor, a 13-inch propeller, and 12 Panasonic 1.2-volt high discharge rate batteries

with 900 milliamp-hour capacity. Avionics include a receiver, a speed controller, a servo and pushrod to control the elevator, and a servo and pushrod to control the rudder and tail wheel. The landing gear consists of two forward gear and a tail dragger.

Design Issues

The following sections address the major technical areas in electric powered RPV design and construction. Weights, structures, propulsion, aerodynamics, stability

and control, economics, and production are all covered. A final paragraph will then describe the concept technology demonstrators and their flight validation.

Weights

Overall weight is a critical issue in the design of any aircraft type because of the adverse effects upon range and performance from excess aircraft weight. RPV design is no different. The students were primarily concerned with minimizing the structural weight of their RPVs while maximizing their payload weight capacity. Figure 6 shows the weight breakdown for the Arrow 227 design. Note the large percentage devoted to payload.

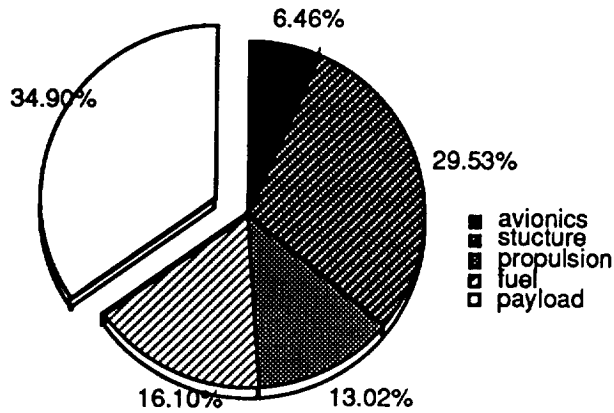

Fig. 6 Subsystem weight breakdown

Analysis of a rather large data base of old RPV designs provided the student design teams with some preliminary weight estimates, but accurate preliminary weight prediction was difficult because of the significant dependence of overall weight upon manufacturing techniques.

Structures

The primary concern of the students in this area was to create the lightest possible structure that could handle the maximum flight loads that the RPV would encounter. A finite element structural optimization program called

SWIFTOS, written by Richard Swift, was a particularly useful tool employed by the student groups for the structural design of their wings. Truss structures were typically used for the RPV fuselage designs, with a three-dimensional finite element truss program used for the primary analysis. The limited manufacturing expertise of the students along with the construction time limitations posed serious barriers for the use of more advanced structures such as circular fuselage sections and tapered wings. Another factor in the structural design was the amount of labor hours necessary to fabricate the RPV. High labor hours increased the production cost which adversely affected the economic profitability of the RPV in the Aeroworld market.

Propulsion

Electric propulsion systems were required for the RPV designs primarily because of safety considerations. Electric propulsion provides some unique challenges in RPV design as opposed to gas propulsion due to its significantly lower thrust to weight ratio. Determination of the proper propulsion system combination of batteries, an electric motor, and a propeller proved to be critical in the success of each RPV. Figure 7 is a schematic diagram of the propulsion system arrangement used in the Hermes CX-7.

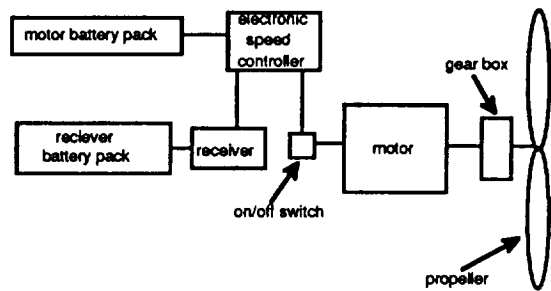

Fig. 7 Schematic of basic propulsion system

Take-off power requirements exceeded the low speed, steady cruise requirements as the primary driver in

propeller selection; whereas current draw at steady cruise proved to be the primary factor in battery selection. Various computer-based methods were available to provide performance predictions for the electric motors. Propeller analysis was primarily done with a computer program based upon simple blade element theory. Accurate performance predictions for the propellers operating in this low Reynolds number regime proved difficult and the flight validation indicated that some of the propeller selections could have been improved. All of the RPVs except the helicopter used the Astro-15 motor. The helicopter group used a special Astro-05 helicopter motor for their prototype RPV as a substitute for the Astro-25 in their design. None of the other student groups deemed the extra power of the Astro-25 and its corresponding weight increase to be necessary, nor did they believe that the weight benefit of the lighter Astro-05 would overcome the handicap of that motor's significantly lower power.

Aerodynamics

Induced drag and the low Reynolds number flight regime, along with the Aeroworld constraints of airport gate size and a 30 ft/s "speed of sound" limitation were some of the primary drivers in the aerodynamic design of the RPV wings. The desire for high aspect ratio wing designs to reduce induced drag conflicted with the Aeroworld gate limitations on wing span.

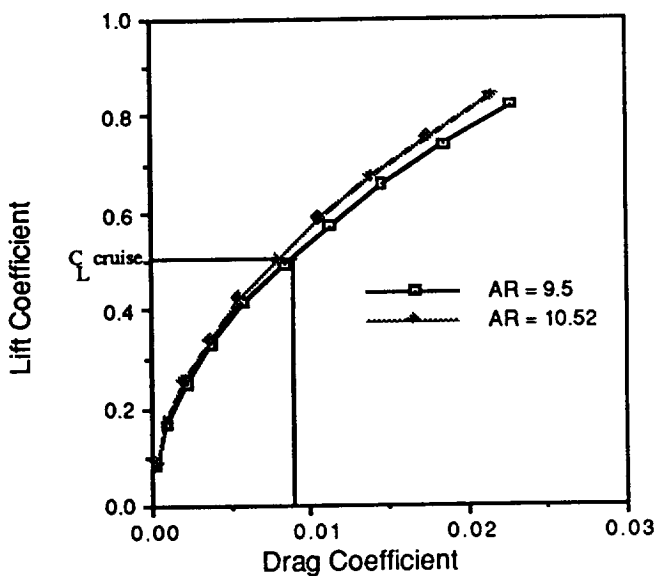

Fig. 8 Induced drag dependence on aspect ratio

Figure 8 illustrates the drag reduction benefits of higher aspect ratio wings. A number of groups opted for folding wing tips as a compromise.

The low Reynolds number flight regime, typically 10^5 to 1.5×10^5 , made drag prediction difficult. The use of low Reynolds number airfoil sections was typical. Certain advanced aerodynamic characteristics such as taper, twist, or complex airfoil geometries were often eliminated from the wing designs due to anticipated fabrication problems. The "Mach number" limit did not carry a "penalty" and was primarily invoked only for safety considerations associated with the indoor flight tests. Most groups attempted to achieve cruise near L/D_{max} . Typical cruise speeds ranged between 25 ft/s and 30 ft/s. Although the high induced drag and low Reynolds number flight regime imposed by the "Mach number" limit made this difficult, most groups had at least some degree of success with their efforts.

Stability and Control

Most groups concentrated their efforts in this area at providing adequate static pitch stability and the necessary roll control to perform the closed course, indoor maneuvers. Static stability was of particular concern to this year's students since their payload, the cargo cubes, had both variable weight and volume. Particular attention was given to center of gravity travel under a variety of loaded, unloaded, and partially loaded payload configurations. The added complexity of the pitching stability problem in the canard design proved to make that RPV difficult to manage in flight testing.

Control of the RPVs was usually accomplished with two channels, elevator, and rudder. This eliminated the extra weight and complexity of the additional controls for ailerons. Turning was accomplished using the combination of rudder and wing dihedral. One RPV, the canard configuration, had a single control surface which alternately performed aileron and elevator functions. Flight success was limited as that RPV did crash a few times during flight testing due to marginal pitching stability and control. Previous RPV designs had demonstrated the feasibility of the two-channel control concepts and other than issues related to control surface sizing and actuator sensitivity and installation, few

significant problems were encountered.

Economics

The overall goal of each design team, regardless of the particular market they wished to address or the type of RPV they designed, was to make a profit based upon the Aeroworld economy. Most groups decided that fuel costs and production costs were the primary economic drivers, with maintenance costs and other operational costs being less critical. The most prominent economic trade-offs occurred when the groups decided the extra production cost of more advanced aerodynamic designs, such as circular fuselage sections and tapered wings, would offset any reduction in fuel costs due to the reduced drag. Hence most groups chose to quickly build the most aerodynamically efficient rectangular wings and truss fuselages that they could, rather than spend extra production time and money on more advanced designs.

Although the Aeroworld economy may not exactly reflect the real world economy with regard to the relative scale of its economic drivers, it did fulfill its primary purpose which was to make the students include economic constraints as well as technical constraints in their designs.

Production

Since each group has limited manufacturing experience and only two weeks to construct the technology demonstrator, the design is largely influenced by ease of construction. Airfoil complexity, wing taper, fuselage cross-section, type and placement of the control systems, and internal structural arrangement are all influenced by the manufacturing requirement. The tools and materials available to the students make it more difficult to incorporate new technologies, such as metal structures and circular fuselages. Complex airfoil shapes coupled with inexperienced wing builders have been the cause of many problems with some RPVs in testing because slight inaccuracies in the construction of airfoils can cause large differences in aerodynamic performance. A few unwanted degrees of twist in either side of an RPV wing can cause a large asymmetry in lift.

The requirement to produce a product in a finite time,

with a limited budget, is probably the most important design driver. Every decision appears to be influenced by this factor.

Technology Demonstrators

Each design team constructed their prototype RPVs during the last three weeks of the project. All groups except the helicopter group were provided with a remote control radio system and an Astro-15 engine. The helicopter group was provided with a specialized helicopter engine, gear set, and transfer case, as well as tail and main rotors. All construction took place in the Hessert Aerospace Design Lab, where simple construction equipment was available for student use. After a construction period of approximately two weeks, a series of taxi tests was performed to test the propulsion and control systems and to check the RPVs for basic flight worthiness. All but one of the RPVs experienced problems, especially in the areas of CG placement, control surface sensitivity, asymmetric lift distribution, and propulsion system battery performance. As expected, those designs which were the most conventional had the most success in initial flight tests.

On Friday, May 1, 1992, the flight demonstrations were held in the Loftus indoor sports arena. Three of the six aircraft and the helicopter successfully performed take-off and sustained, controlled flight. The three successful RPVs were the conventional designs: Hermes CX-7, Arrow 227, and Exodus Prime Mover. The other two aircraft, the canard and biplane configurations, Jeff and Reliant, attained flight, but could not be kept under control for a sustained period of time. The canard's primary flight difficulty was caused by the combination of marginal pitching stability, oversensitive elevator control and thrust coupling to pitch control. The biplane suffered from an asymmetric lift distribution which was the result of construction difficulties with the wings. Considering the lack of experience of the builders and the time constraints placed on the teams, this flight demonstration was considered a great success, and showed the students the difference between a conceptual success and success in the real world.

Conclusions

The students entered the course with the knowledge required to complete the mission. The learning process involved the ability to incorporate that knowledge into a single integrated design. They were involved with the design process all the way from the mission definition to the prototype flight testing. Each student encountered many real world problems including working with a team of peers on a single aircraft design. The construction process allowed the students the experience of transforming a design concept from paper into a flightworthy aircraft.

The attempt to simulate numerous issues related to a commercial cargo transportation system design through the use of an RPV system and the Aeroworld economic and demographic model was largely successful.

Acknowledgments

This project was supported by NASA/USRA Advanced Aeronautics Design Program. Technical assistance and guidance was provided by the Boeing Company under the coordination of Mr. Cal Watson. Thanks also to Boeing's Mr. Ben Almojuela for his participation in the preliminary design review. The course was presented by Dr. Stephen M. Batill and graduate teaching assistants Jim Pinkelman, Ken Cheung, Nat Georges, and Kevin Costello. Finally, thanks to Mr. Joseph Mergen, Mr. Tony DeRoza, Mr. Kane Kinyon, Mr. Joel Preston, and Mr. Mike Swadener for their technical assistance and advice throughout the semester.