

**THE DESIGN OF FOUR HYPERSONIC RECONNAISSANCE AIRCRAFT**

**The Ohio State University  
Department of Aeronautical and Astronautical Engineering  
Columbus, Ohio**

**Professor G.M. Gregorek  
D.T. Detwiler, Teaching Assistant**

**Abstract**

Four different hypersonic reconnaissance aircraft were designed by separate student teams. These aircraft were designed to provide the U.S. with a system to acquire aerial tactical reconnaissance when satellite reconnaissance proved unobtainable or ineffective. The design requirements given for this project stated that these aircraft must carry a 7500 lb, 250 cu ft payload of electronic and photographic intelligence gathering equipment over a target area at speeds between Mach 4-7 and at altitudes above 80,000 ft. Two of the aircraft were required to be manned by a crew of two and have a range of 12,000 nmi. One of these was to use airborne refueling to complete its mission while the other was not to use any refueling. The other two aircraft were required to be unmanned with a range of 6,000 nmi. One of these was to take off from a naval vessel while the other was to be launched from another aircraft. This paper provides the final details of all four aircraft designs along with an overview of the design process.

**Introduction**

The Ohio State University (OSU) Advanced Design Program (ADP) continues the tradition of hypersonic vehicle design with this year's project. Past projects for this program at OSU range from high speed cruise vehicles, including commercial 250-passenger transports and executive 10-passenger aircraft, to accelerating type vehicles, such as a Mach 10 scramjet test bed and a two stage to orbit vehicle. This year's project, a hypersonic reconnaissance aircraft, presents its own set of unique design challenges.

The majority of U.S. reconnaissance and surveillance intelligence is obtained by satellites. These spy satellites are sometimes unable to obtain vital intelligence due to

orbital restrictions or weather conditions. This gap in U.S. reconnaissance capabilities was filled in the past by the Lockheed SR-71 reconnaissance aircraft until its retirement in January, 1991. A replacement for this exceptional aircraft is needed. The four aircraft presented in this paper are intended for this purpose.

**Project Requirements**

The design requirements set for the four aircraft were intended to represent current U.S. reconnaissance needs. These needs include a real time response coupled with a near-global range. This combination requires cruising at hypersonic speeds between Mach 4-7. The upper limit of Mach 7 was imposed because of thermal and structural constraints determined from current literature. These aircraft will be required to complete their mission over hostile territory. The high cruising speed and a cruising altitude above 80,000 ft are advantageous for survivability. There has been a serious debate over the necessity of a crew for this type of aircraft. Therefore, two of the aircraft were required to be manned while the other two were unmanned to provide a comparison. The diverse nature of these types of missions make several different operational capabilities attractive. Four possible mission scenarios were created, two with ranges of 12,000 nmi for the manned aircraft, and the other two with ranges of 6,000 nmi for the unmanned aircraft (Figures 1 and 2)

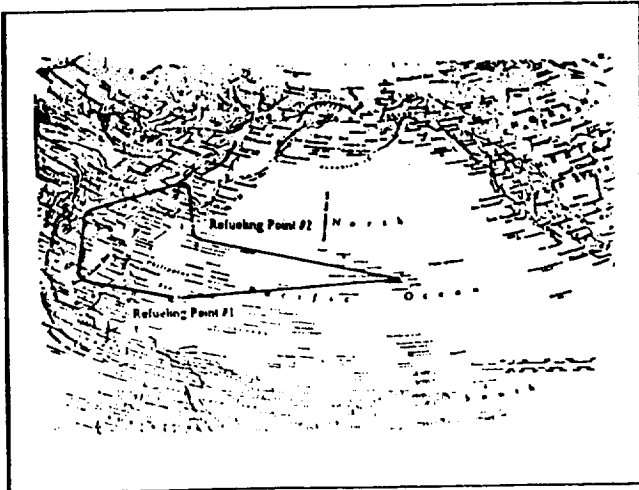

Fig. 1 12,000 nmi reconnaissance mission

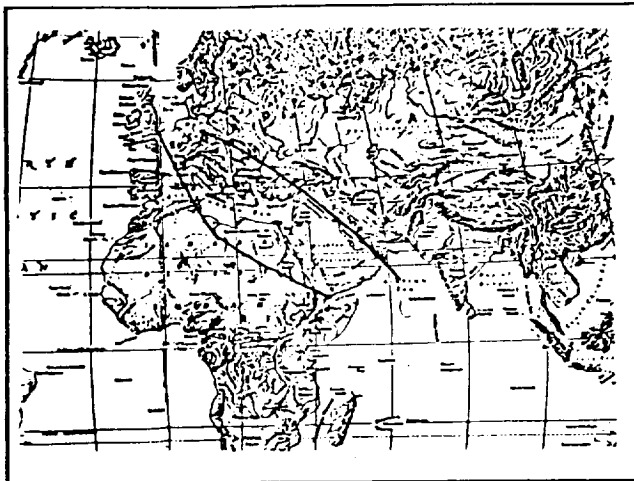

Fig. 2 6,000 nmi reconnaissance mission

The possibility of airborne refueling was studied by requiring one of the manned aircraft to use airborne refueling, while the other was required to complete the same mission without it. The tanker aircraft that provided the refueling for the above case was designed by engineering students from Ecole Polytechnique Feminine (EPF) in Paris, France. The possibilities of sea launch from a naval vessel and air launch from another aircraft were examined for the two unmanned vehicles. The general design requirements for all four aircraft and the mission specific requirements for each aircraft follow in Tables 1 and 2.

Table 1 General Design Requirements

Cruise speed	Mach 4-7
Propulsion	Airbreathing (cruise)
Payload weight	7500 lbs
Payload volume	250 cu ft
TO/Landing distance	10,000 ft

Table 2 Design Team Requirements

Group	Mission	Range (nm)	Crew
GRAY I	Airborne refueling	12,000	2
GRAY II	No refueling	12,000	2
SCARLET I	Air launched	6,000	Unmanned
SCARLET II	Sea launched	6,000	Unmanned

**Design Program Outline**

The ADP at OSU consists of three separate classes over the entire academic year. These include a one credit hour seminar during Autumn Quarter, a four credit hour Aerospace Vehicle Design Course during Winter Quarter, and an Advanced Vehicle Design Course during Spring Quarter.

The first course offers the students the opportunity to hear seminars from design engineers in the industry and government. These professionals speak about the design process and some specific problems created by operating in a hypersonic speed regime. The students were also asked to do a conceptual design of a primary trainer aircraft for this course. This allowed the students to familiarize themselves with the aspects of aircraft design. Roskam's first *Aircraft Design* book<sup>1</sup> was used for this project.

The students were divided into four separate design teams at the beginning of Winter Quarter. These teams consisted of a team leader and members specializing in one or more disciplines, such as aerodynamics, propulsion systems, etc. Since there is a separate structural design course offered at OSU, no structural design was required

for this project. The four groups were given the project requirements, which they incorporated into their own design goals. Trade studies were conducted by the groups dealing with different aerodynamic configurations and propulsion systems. The results of these studies and estimates of dimensions and weights were used to create a conceptual design and to do initial trajectory analysis.

The design cycle was continued during Spring Quarter by employing an iteration process. The groups attempted to optimize their trajectories and thereby minimize their weights. The details of each design, such as stability and control, thermal protection systems, and component weight analysis, were included. The groups were expected to give oral presentations on their progress on a regular basis and to turn in a final paper at the end of each quarter.

### Aircraft Designs

The four design groups were designated GRAY I and GRAY II for the two manned aircraft and SCARLET I and SCARLET II for the two unmanned aircraft. Each group operated independently and in a spirit of friendly competition with the others. The Teaching Associate functioned as a project manager to make sure that all the groups stayed on track.

The GRAY I aircraft (Figure 3) is a 207 ft-long conventional double delta wing-body configuration. It cruises at a speed of Mach 5 and an altitude above 80,000 ft for most of its 12,000 nmi range. However, this aircraft does descend to an altitude of 40,000 ft and decelerates to a speed of Mach 0.8 for two airborne refueling maneuvers to complete its mission. This wing-body configuration was selected for its balance of low speed and high speed capabilities and its volumetric efficiency. The aircraft is powered by three integrated turbo-ramjets that burn liquid hydrogen fuel. This integrated engine system allows the aircraft to operate at a wide range of speeds while reducing the weight produced by two separate engines. The single fuel, liquid hydrogen, was selected to simplify refueling systems while allowing the aircraft to reach Mach 5. The GRAY I aircraft has a takeoff weight of 281,000 lbs and operates from a standard runway.

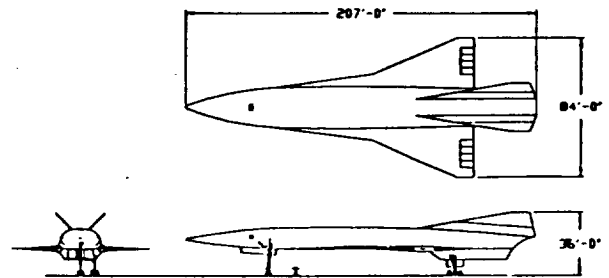

Fig. 3 GRAY I (3-view)

The GRAY II aircraft (Figure 4) is a 188-ft long waverider configuration. It cruises at Mach 4 and 80,000 ft. This aircraft was required to complete its mission range of 12,000 nmi without refueling. Therefore, the GRAY II group optimized their aircraft for hypersonic cruise conditions. A waverider vehicle was chosen for this purpose. The aircraft is powered by six augmented turbojet engines that burn liquid hydrogen fuel. The weight of the fuel was determined to be the critical design variable for this aircraft. This engine system was chosen to minimize specific fuel consumption. The liquid hydrogen fuel was selected for its high energy per unit mass content. The GRAY II aircraft has a takeoff weight of 558,000 lbs and operates from a standard runway.

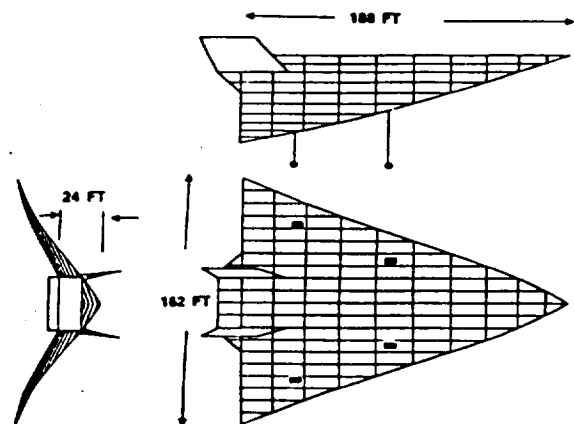

Fig. 4 GRAY II (3-view)

The SCARLET I aircraft (Figure 5) is a 61-ft long, lifting body configuration. It cruises at Mach 5 and 80,000 ft. This aircraft was designed to be launched from another aircraft traveling at Mach .8 and 35,000 ft. The capabilities of possible launch aircraft imposed serious size and weight constraints for this group. A lifting-body configuration was chosen for its volumetric efficiency. The aircraft is powered by four over/under rocket-ramjet engines. The liquid oxygen-hydrogen burning rockets power the vehicle during ascent, while the methane burning ramjets are used during cruise. The rockets were selected for the quick ascent to minimize engine weight. Methane was used to power the ramjets because it provided the necessary SFC while meeting the size and weight constraints. The SCARLET I aircraft has a launch weight of 130,000 lbs and lands unpowered on a standard runway.

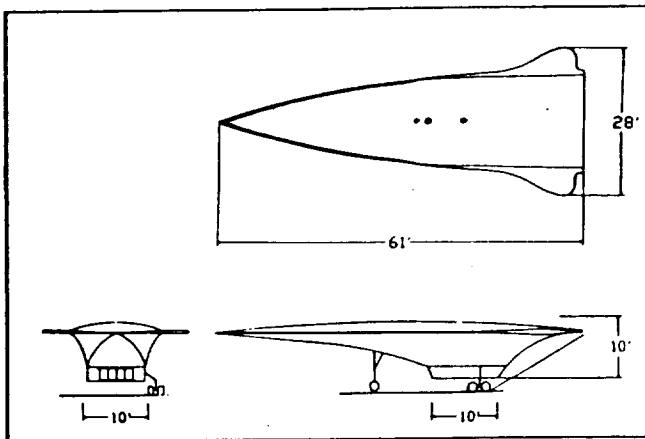

Fig. 5 SCARLET I (3-view)

The SCARLET II aircraft (Figure 6) is a 79.5-ft long waverider configuration. It cruises at MACH 4 and 80,000 ft. This aircraft was designed to operate from a Naval aircraft carrier. The constraints imposed on carrier-based aircraft include a maximum length of 80 ft, a maximum wing span of 52 ft, and a maximum weight of 100,000 lbs. A waverider configuration was selected because it provided optimal cruising characteristics while meeting all of the constraints. The aircraft is powered by two augmented turbofan engines burning JP-X. The turbofan was chosen for its superior performance at takeoff speed and to minimize engine system weight. The JP-X fuel was selected to meet volume constraints imposed by the waverider configuration and

environmental requirements for storage aboard an aircraft carrier. The SCARLET II aircraft has a takeoff weight of 100,000 lbs and operates from a naval aircraft carrier. The carrier's catapult is used for an assisted takeoff.

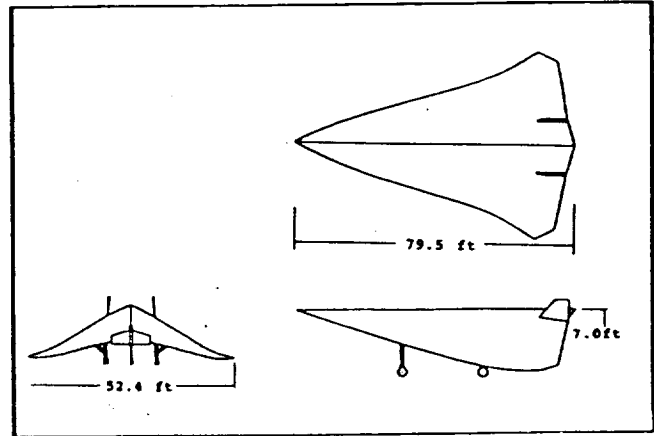

Fig. 6 SCARLET II (3-view)

### Design Methods

The hypersonic reconnaissance aircraft is a cruise vehicle. Therefore, it is advantageous to optimize for a set cruise condition. However, the various constraints placed on the four aircraft by their respective missions often conflict with this optimization. This leads to a series of compromises to reach the desired design goals. The following sections provide details of the various technical disciplines incorporated into the design process.

### Propulsion

The focus in designing a propulsion system is to select engine and fuel types that satisfy the mission requirements while minimizing the overall weight of the aircraft. This requires initial trade studies that compare the various possibilities. Figure 7 shows the mass and volumetric energy density comparison for various fuels for airbreathing engines. Liquid hydrogen possesses the highest mass energy density, but its low volumetric density produces serious volume requirements. The JP fuel has a much lower mass energy density and therefore a greater relative weight, but its high volumetric density provides greater volumetric efficiency. The methane fuel is a balance between the two others. Cryogenic fuels such as

liquid hydrogen and corrosive fuels such as methane have several operational problems which must be answered before use. The JP fuel has a maximum speed capability of Mach 4.

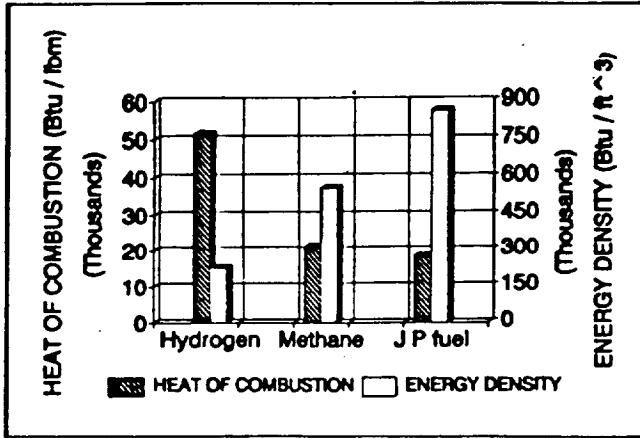

Fig. 7 Comparison of fuels

A single, multiple, or hybrid engine system must be selected to produce the required thrust over the entire flight envelope. Figure 8 shows several engine types. A cruising speed of Mach 4-7 for this type of vehicle requires a turbojet or ramjet engine. The turbojet has an operational speed limitation of Mach 4. A rocket engine is also a possibility, but its low specific impulse makes it very inefficient for long cruise applications. These aircraft are required to operate over a wide range of Mach numbers during the takeoff/landing and ascent/descent phases of the mission. Those aircraft equipped with ramjets for cruise must have multiple or hybrid systems for lower speeds.

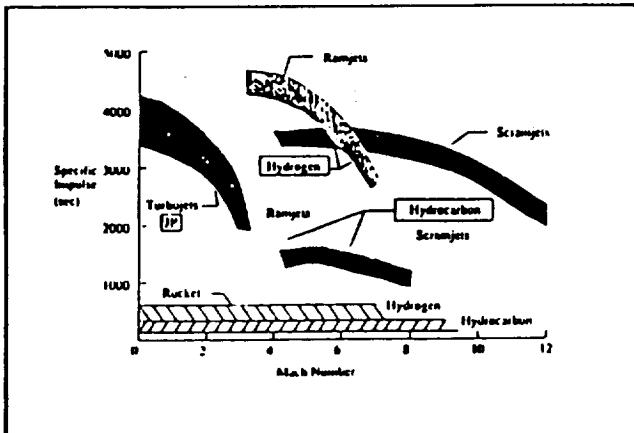

Fig. 8 Propulsion alternatives

The maximum net thrust produced by each group's propulsion system at specified Mach numbers and altitudes was obtained (Figure 9). This was done in part by scaling performance data provided by General Electric on several turbojet, turbofan, and ramjet concepts. The flexible ramjet/scramjet engine simulation program, RAMSCRAM, provided by NASA Lewis Research Center was also used to generate engine performance data.<sup>2</sup> All engine data assumes mil-spec inlet and nozzle efficiencies.

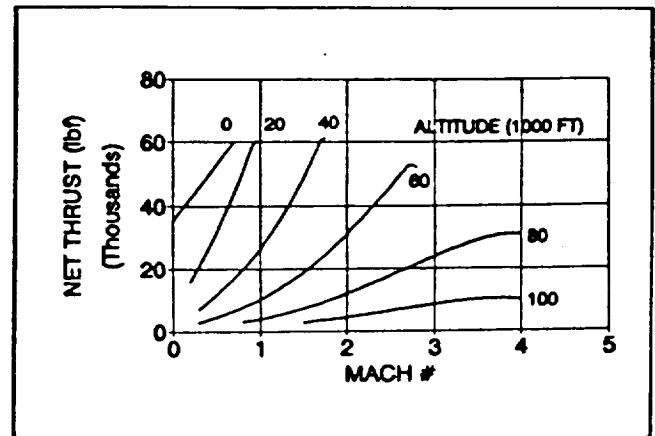

Fig. 9 Engine performance

This engine data was incorporated into the trajectory analysis as thrust available. The results of the trajectory analysis were then used to scale the number and size of the engines according to the critical design point.

### Aerodynamics

The aerodynamic analysis of the vehicles was conducted using a variety of methods. Those methods outlined in Nicolai's book, *Fundamentals of Aircraft Design*,<sup>3</sup> and Raymer's book, *Aircraft Design: A Conceptual Approach*,<sup>4</sup> were primarily used along with shock expansion theory and Newtonian methods. The two waverider configurations were approximated by equivalent flat plate delta-wings.

These waverider configurations were created using the MAXWARP program developed at the University of Maryland.<sup>5</sup> The waverider is optimized for a given Mach number and altitude. This makes it ideal for a cruise

vehicle.

The hypersonic aerodynamic characteristics for the lifting-body configuration were obtained using the computer panel code called APAS developed by NASA Langley Research Center.<sup>6</sup> The body geometry was broken down into several meshed surfaces. The code then analyzed them using the tangent cone, tangent wedge, and Dahlem Buck theories.

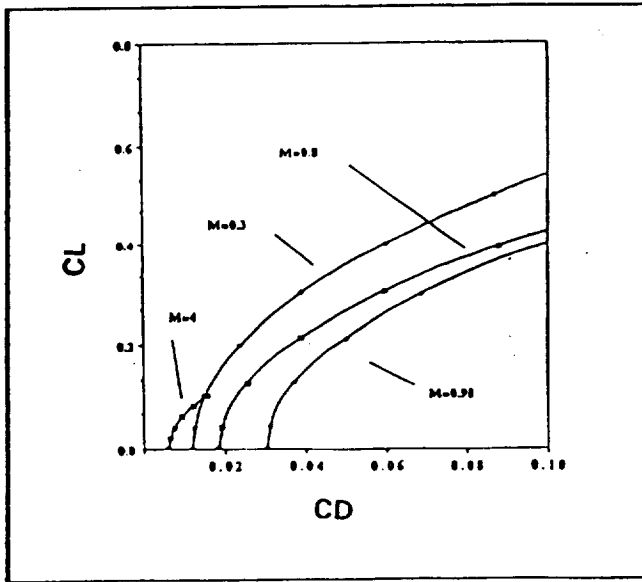

Fig. 10 Drag polar

All of the aerodynamic characteristics were used to generate drag polars for each aircraft (Figure 10). These drag polars were in turn used to produce lift-to-drag ratios for the trajectory analysis (Figures 11 and 12).

Wind tunnel models were constructed for the wing-body and lifting-body configurations. These modes were tested in the OSU Low Speed Wind Tunnel. Figure 13 shows the suspension of the wing-body model from the test mount. This arrangement was used to produce experimental lift-to-drag ratios. This experimental data was used for correlation with the analytical results.

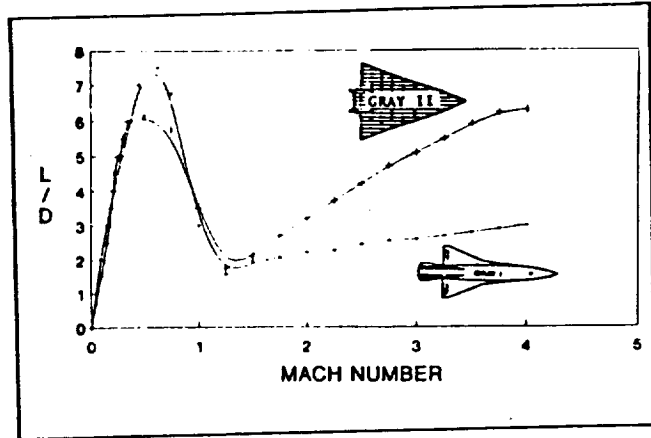

Fig. 11 L/D vs. Mach number

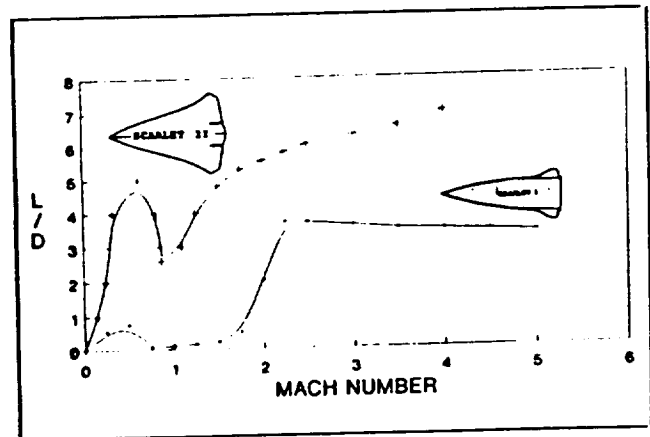

Fig. 12 L/D vs. Mach number

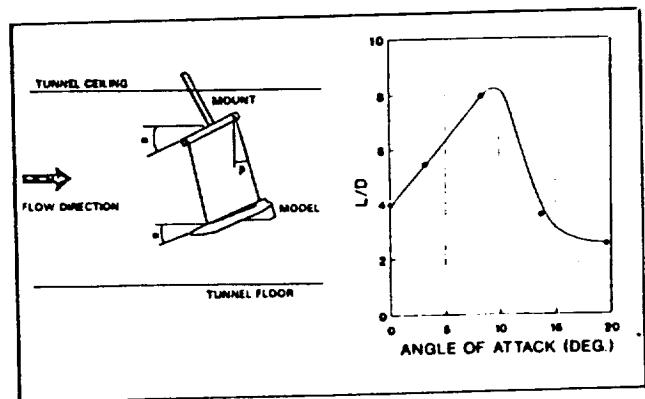

Fig. 13 Wind tunnel testing

## Weight

The component weight analysis for the aircraft was obtained using the WAATS<sup>7</sup> and HASA<sup>8</sup> computer programs provided by the NASA Lewis Research Center. These programs used aerodynamic geometry and propulsion parameters as inputs. The weights calculated in this fashion were used in the trajectory analysis. As the design iteration process continued, these inputs were updated to recalculate the weights.

A component weight breakdown for each aircraft is shown in Figure 14. The fuel weight comprises over fifty percent of the total weight for all the aircraft. This is expected for a cruise vehicle. The two GRAY aircraft are much heavier than the two SCARLET aircraft. This is mostly due to the greater range (12,000 nmi) of the GRAY aircraft. The use of airborne refueling produces a lighter weight of 281,000 lbs for the GRAY I aircraft compared to 558,000 lbs for the GRAY II aircraft. The air-launched SCARLET I and the sea-launched SCARLET II aircraft have almost identical weights of 130,000 lbs and 100,000 lbs respectively.

## Trajectory

The trajectory analysis is the core of the aircraft design process. The propulsion, aerodynamic, and weight data are used as inputs to determine the aircraft's ability to meet the mission requirements. If these requirements are not met, then the previous propulsion, aerodynamic, and weight data must be updated and the cycle repeated until a viable design is produced. Once an aircraft that satisfies all requirements has been obtained, optimization procedures are used to produce the best possible design according to determined design goals.

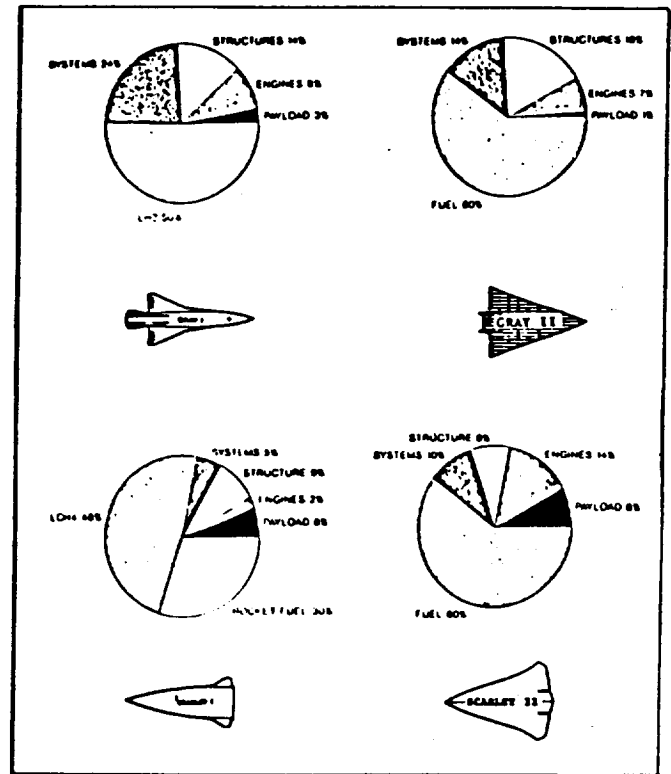

Fig. 14 Total weight breakdown

All four hypersonic reconnaissance aircraft follow very similar mission profiles. After takeoff or launch, the aircraft climb and accelerate toward Mach 1. The aircraft must punch through the transonic region. They then continue to accelerate and climb at a constant dynamic pressure up to cruise altitude and speed. After cruising the required mission range the aircraft descend, possibly at the maximum lift-to-drag ratio, until landing. Figure 15 shows the mission acceleration profile for the GRAY II aircraft. In this case the aircraft executes a constant specific energy dive to pass through the transonic region. This allowed the team to reduce the size of their aircraft's engines and thereby reduce the overall weight of their aircraft.

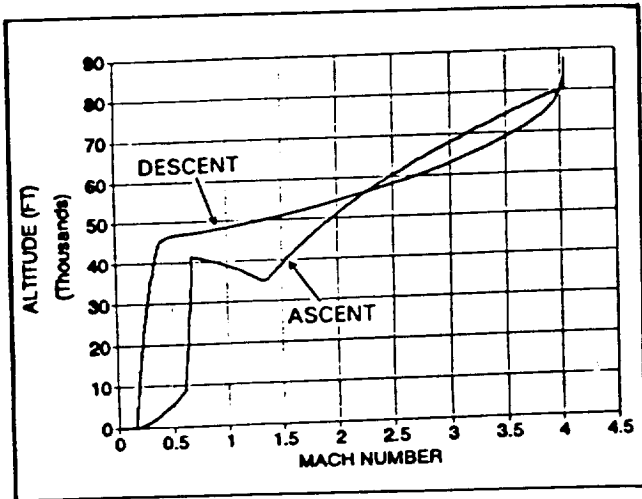

Fig. 15 Mission acceleration

A viable aircraft design is one for which the thrust available is greater than the thrust required throughout the mission trajectory. The thrust available is the maximum net thrust produced by the engines at determined flight path altitudes and mach numbers. The thrust required is the minimum thrust to allow the aircraft to climb and accelerate through a determined flight path. Figure 16 shows curves of thrust available and thrust required versus Mach number for the GRAY I aircraft. If the thrust available curve fell below the thrust required curve at any point then the design parameters would be changed and another analysis conducted. The closest point between the two curves is the critical design point. The aircraft's engine system is sized for this region.

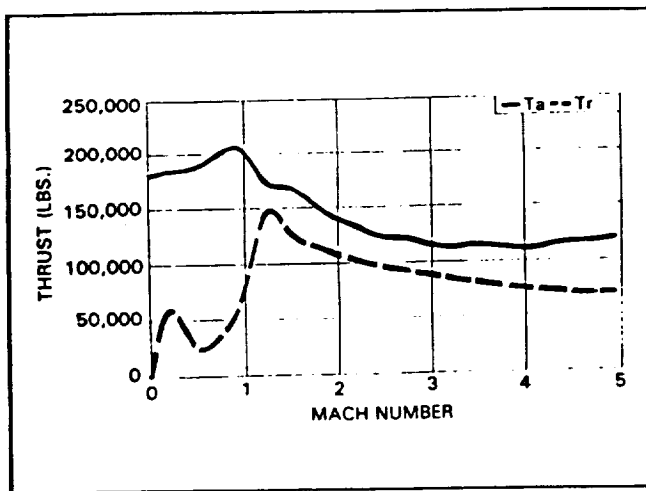

Fig. 16 Thrust available and required vs. Mach number

The GRAY I team chose to optimize further their ascent trajectory. This was accomplished using energy-state methods. The curves shown in Figure 17 are specific fuel consumption contours. Specific fuel consumption is defined as the change in specific energy with respect to the change in fuel weight.<sup>4</sup> These contours are plotted along with constant total energy curves not shown in the figure. The points where the two sets of curves become tangent mark the minimum fuel-to-climb trajectory. This minimum fuel-to-climb flight path is followed until it intersects the constant dynamic pressure flight path. Since the weight of fuel was found to have a significant effect on the total weight of the aircraft, this trajectory minimized the total weight.

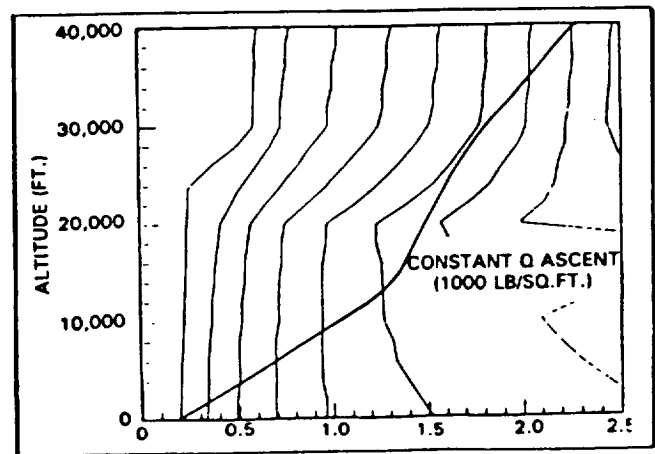

Fig. 17 Minimum fuel-to-climb rate

### Conclusion

Four conceptual designs of hypersonic reconnaissance aircraft have been completed by independent student design teams. These aircraft were designed to provide the U.S. with a flexible and reliable system to collect intelligence data around the globe within hours. This type of aircraft is seen as a next generation replacement of the Lockheed SR-71.

Table 3 compares the four different aircraft designs. There is a large difference in total weights of the two manned and the two unmanned aircraft. This is due to the difference between their respective ranges. The addition of two crew members and a cockpit is only a very small fraction of the total weight. The real differences between the two cases are operational and economic



factors that still need to be examined.

The capability of airborne refueling contributed to an aircraft with a total weight of approximately fifty percent less than one without it. The problems of airborne cryogenic refueling were studied by the French design team from EPF.

There are still questions to be answered and details to be added to these conceptual designs. But, this project has achieved its goal. The students have discovered the cooperation and compromise necessary to conduct multidisciplinary design in a team effort.

### References

1. Roskam, J. Airplane Design, University of Kansas, 1986.
2. Burkhardt, L. and Franciscus L. "RAMSCRAM - A Flexible Ramjet/Scramjet Engine Simulation Program." Technical Manual, 1990.
3. Nicolai, L.M. Fundamentals of Aircraft Design, San Jose, CA: METS, Inc., 1974.
4. Raymer, Daniel P. Aircraft Design: A Conceptual Approach, AIAA, 1989.
5. Corda, S. "Viscous Optimized Hypersonic Waveriders Designed from Flows over Cones and Minimum Drag Bodies," University of Maryland, 1988.
6. NASA Langley Research Center. APAS Computer Software, 1991.
7. Glatt, C.R. "WAATS - A Computer Program for Weights Analysis of Advanced Transportation," CR-2420, 1974.
8. Harloff, G.J. and Berkowitz, B.M. "HASA - Hypersonic Aerospace Sizing Analysis for the Preliminary Design of Aerospace Vehicles." CR-182226, 1988.

Table 3 Aircraft specifications

	GRAY I	GRAY II	SCARLET I	SCARLET II
Configuration	Wing-body	Waverider	Lifting body	Waverider
Planform area (sq ft)	3,000	13,475	854	2,300
Cruise speed (kts)	Mach 5.0	Mach 4.0	Mach 5.0	Mach 4.0
Cruise altitude (ft)	92,000	80,000	80,000	80,000
Mission time (hrs)	3.0	5.5	2.1	3.0
Total weight (lbs)	281,000	558,000	130,000	100,000
Engines	3 integrated turbojet/ramjets	6 augmented turbojets	4 rocket/ramjets	2 augmented turbofans
Fuel	LH <sub>2</sub>	LH <sub>2</sub>	LO/LH <sub>2</sub> + methane	JP-X