

NASA CR-179548
RI/RD 86 - 214

1N-37
028981
(NASA-CR-179548) DESIGN AND
EXPERIMENTAL PERFORMANCE OF A TWO
STAGE PARTIAL ADMISSION TURBINE.
TASK B.1/B.4 Final Report, Dec.
1984 - Jun. 1986 (Rockwell
International Corp.) 168 p

N94-27228

Unclas

G3/37 0208981

430291

FINAL REPORT

Design and Experimental Performance of a Two Stage Partial Admission Turbine Task B.1 / B.4

by

Rocketdyne Engineering

Rocketdyne Division

Rockwell International

prepared for

NATIONAL AERONAUTICS AND SPACE ADMINISTRATION

December 1992

NASA-Lewis Research Center
Cleveland, Ohio 44135

Contract NAS3-23773

G. Paul Richter, Project Manager

FOREWORD

The work presented herein was conducted from December 1984 to June 1986 by personnel from Engineering functional units at Rocketdyne, a division of Rockwell International, under Contract NAS3-23773. Mr. Dean Scheer, Lewis-Research Center, was the NASA Project Manager. At Rocketdyne, Messrs. Anthony Zachary, Program Manager, and Robert F. Sutton, Project Engineer, were responsible for the direction of the program.

Important contributions to the conduct of the program, and to the preparation of the report material were made by the following Rocketdyne personnel:

Advanced Turbomachinery Projects	Mr. Dan Shea Mr. Edmund Roschak
Hydrodynamics and Aerodynamics	Mr. Jim Boynton Mr. Lou Rojas
Structures	Mr. Linsey Orr
Dynamics	Ms. Linda Davis
Engineering Development Laboratory	Mr. Brad King Mr. Bill Bubel Mr. Joe Lichatowich Mr. John McPherson Mr. Ted Davis Ms. Dawn Elliott Mr. Robert Herbig

TABLE OF CONTENTS

FOREWORDi

LIST OF FIGURESi i

LIST OF TABLESv

SUMMARY1

INTRODUCTION4

OBJECTIVES6

TECHNICAL DISCUSSION7

 MK49-F TURBINE DESIGN.....7

 TESTER DESIGN AND DESCRIPTION.....1 6

 ROTOR DYNAMIC ANALYSIS2 1

 FACILITY DESCRIPTION3 0

 INSTRUMENTATION3 4

 DATA ACQUISITION AND ANALYSIS3 7

 TEST MATRIX AND PROCEDURES.....3 9

TEST RESULTS4 1

 DESIGN ADMISSION CONFIGURATION4 8

 Design Configuration Efficiency Characteristic4 8

 Design Configuration Flow Characteristic.....5 3

 Design Configuration Static Pressure Distribution5 6

 Design Configuration Turbine Rotor Axial Thrust.....6 6

 HALF DESIGN ADMISSION CONFIGURATION6 9

 Half Configuration Efficiency Characteristic6 9

 Half Configuration Flow Characteristic.....7 3

 Half Configuration Static Pressure Distribution7 3

 Half Configuration Turbine Rotor Axial Thrust.....7 3

 QUARTER DESIGN ADMISSION CONFIGURATION8 0

 Quarter Configuration Efficiency Characteristic8 0

 Quarter Configuration Flow Characteristic.....8 4

 Quarter Configuration Static Pressure Distribution8 7

 Quarter Configuration Turbine Rotor Axial Thrust.....8 7

CONCLUSIONS9 2

REFERENCES.....9 4

APPENDIX A Standard Air Equivalent Conditions9 5

APPENDIX B Raw Data, Tests 8-10 (Pressure Distribution).....9 7

APPENDIX C Data Reduction Technique13 1

APPENDIX D Raw and Reduced Data, Tests 11-13.....14 0

LIST OF FIGURES

1. Program Schedule.....	2
2. MK49-F Liquid Hydrogen Turbopump.....	5
3. Blade Path Mean State Conditions at Design.....	9
4. Velocity Vector Diagram.....	10
5. MK49-F Turbine Cross Section.....	11
6. Blade Path Design Data.....	12
7. First and Second Stage Nozzle Angular Orientation.....	13
8. Two Stage Partial Admission Turbine Blade Coordinates.....	14
9. Performance Characteristics.....	15
10. Two stage, Partial Admission Turbine Tester.....	18
11. First and Second Stage Nozzle Turbine Wheels.....	22
12. Tester Components.....	23
13. Second Stage Nozzle Angular Orientation Motor Drive Setup.....	24
14. Load Path Diagram.....	25
15. Rotordynamic Critical Speed Plot.....	26
16. Rotor Group Mode Shape - 1st Rotor Mode.....	27
17. Rotor Group Mode Shape - 2nd Rotor Mode.....	28
18. Facility Schematic.....	31
19. Tester Installation.....	32
20. Tester Disassembly.....	33
21. Instrumentation Parameter Locations.....	35
22. Static Pressure Tap Locations.....	36
23. Data Acquisition Flow Chart.....	38
24. Efficiency vs. U/CO, Zero Degrees, Three Arcs.....	43
25. Equivalent Flowrate vs. PR (eq) for Arcs of Admission.....	44
26. Interstage Static Pressure Distribution.....	46
27. Efficiency vs. U/CO, Design Configuration.....	49
28. Design Configuration Second Stage Nozzle Orientation.....	50
29. Delta Temperature Efficiency vs. Angle Orientation, Design Configuration.....	52
30. Equivalent Flowrate vs. PR (eq), Design Configuration.....	54
31. Equiv. Flow Parameter vs. Angle Orientation, Design Configuration.....	55
32. Interstage Static Pressure Distribution at Design.....	58
33. Static Pressure Distribution, Design Configuration, 0 Degrees.....	59
34. Static Pressure Distribution, Design Configuration, +40 Degrees.....	61
35. Static Pressure Distribution, Design Configuration, -30 Degrees.....	62

36. Static Pressure Distribution, Design Config., 0 Degrees, 10,052 RPM.....	6 4
37. Static Pressure Distribution, Design Config., 0 Degrees, 25,003 RPM.....	6 5
38. Axial Thrust From Pressure Loads, Design Configuration	6 7
39. Axial Thrust From Pressure Loads, Design Configuration, High Pressure.....	6 8
40. Efficiency vs. U/CO, Half Design Configuration.....	7 0
41. Delta Temperature Efficiency vs. Angle Orientation, Half Design.....	7 2
42. Equivalent Flowrate vs. PR (eq), Half Design Configuration	7 4
43. Equivalent Flowrate vs. Angle Orientation, Half Design Configuration	7 5
44. Interstage Static Pressure Distribution at Half Design.....	7 6
45. Axial Thrust From Pressure Loads, Half Design.....	7 8
46. Axial Thrust From Pressure Loads, Half Design, High Pressure	7 9
47. Efficiency vs. U/CO, Quarter Design Configuration.....	8 1
48. Delta Temperature Efficiency vs. Angle Orientation, Quarter Design.....	8 3
49. Equivalent Flowrate vs. PR (eq), Quarter Design Configuration	8 5
50. Equivalent Flow Parameter vs. Angle Orientation, Quarter Design.....	8 6
51. Interstage Static Pressure Distribution at Quarter Design.....	8 8
52. Axial Thrust From Pressure Loads, Quarter Design.....	9 0
53. Axial Thrust From Pressure Loads, Quarter Design, High Pressure	9 1

LIST OF TABLES

1. Design Requirements for the MK49-F Turbine.....	7
2. MK49-F Turbine/Tester Design Parameters.....	17
3. Nozzle Admission Fractions	19
4. Turbine Tester Parts List.....	20
5. Test Peak Efficiency for Arc of Admission.....	41
6. Turbine Axial Thrust From Pressure Forces.....	47
7. Target N (eq) and PR (eq), Design Arc of Admission.....	51
8. Interstage Static Pressure Distribution Ratios, Design Configuration	57
9. Target N (eq) and PR (eq), Half Design Configuration	71
10. Interstage Static Pressure Distribution Ratios, Half Design Configuration	77
11. Target N (eq) and PR (eq), Quarter Design Configuration.....	82
12. Interstage Static Pressure Distribution Ratios, Quarter Design Configuration	89

SUMMARY

The Rocketdyne Orbital Transfer Vehicle (OTV) rocket engine system's high pressure, liquid hydrogen turbopump was designed with a two stage, partial-admission axial turbine. The turbine is basically two single stage, partial-admission, subsonic impulse stages designed so the kinetic energy leaving the first stage rotor is discharged directly into the second stage nozzle at nominal operation to minimize staging losses. Very little data was available in the literature for this type of turbine design. Therefore, the decision was made to test a full-size model of this turbine design using ambient-temperature gaseous nitrogen as the working fluid.

The effort conducted herein was sponsored by the Space Propulsion Technology Division, NASA Lewis Research Center, Cleveland, Ohio, under Contract NAS3-23773, "Orbit Transfer Rocket Engine Technology Program." The program began in December 1984 and continued through June 1986. **Figure 1** presents the overall program schedule.

The tester design features a rotatable, remote-controlled, variable orientation second stage nozzle system which changes the first to second stage nozzle angulation during a single test period and allows adjustment to the optimum position for highest performance. In addition, this feature minimizes test turnaround time and maintains good test-to-test performance correlations. Nozzle arcs of admission were changed by plugging, or unplugging, a discrete number of nozzles with silicon rubber. Problems with the retention of these plugs during the test program were solved by epoxying the plugs in place.

Figure 1

TASK B.1: TWO STAGE PARTIAL ADMISSION TURBINE PROGRAM SCHEDULE

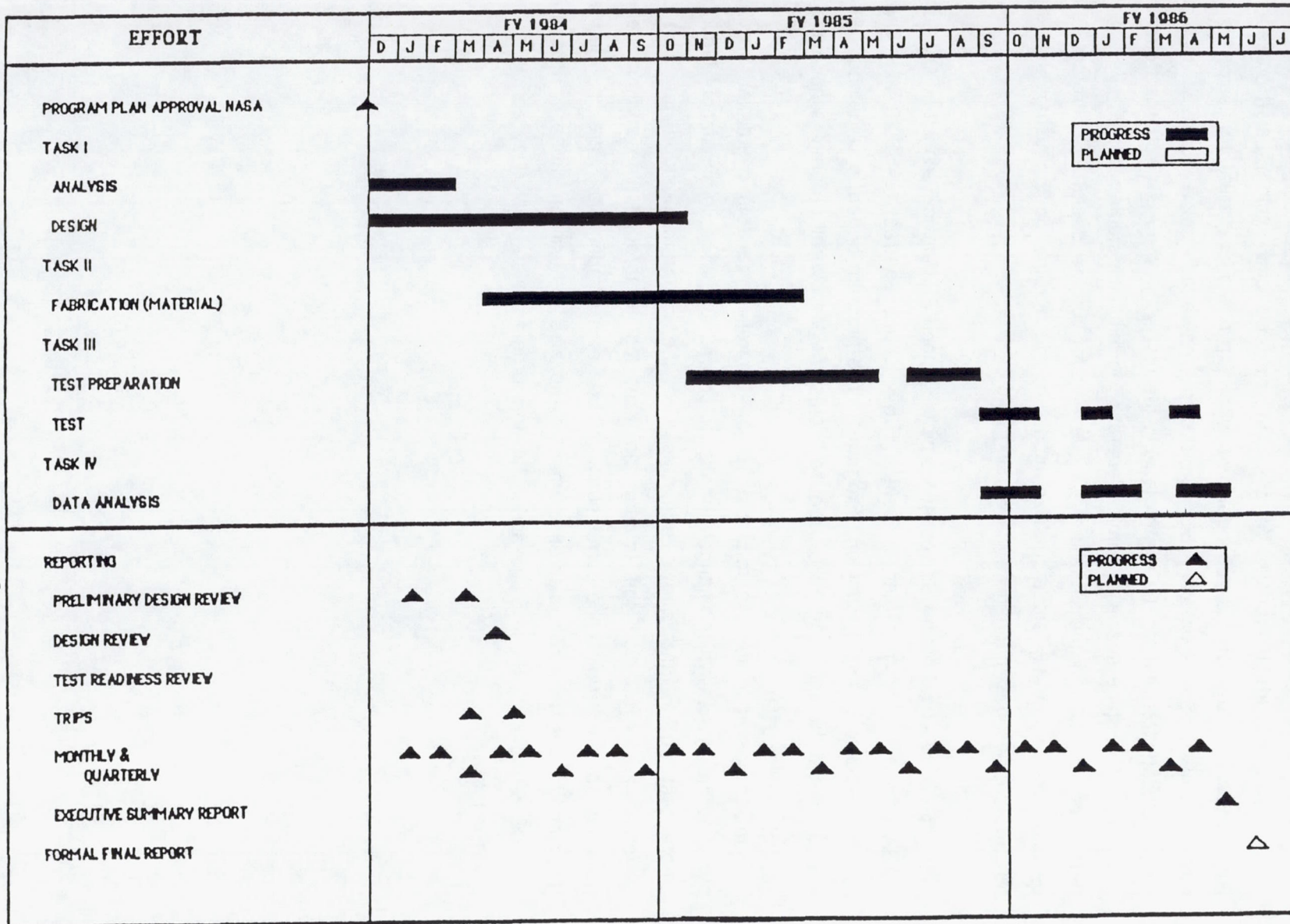

NASA CR-179548
 R/RD 86-214

A total of thirteen tests were conducted in the Rocketdyne Engineering Development Laboratory starting in September 1985 and continuing in three phases until April 1986. Second stage nozzle orientation angles from +40 to -30 degrees from the designed nozzle angular orientation (40 degrees from the center of the first stage nozzle, in the direction of rotor rotation) were tested. Arc of admission variations for the first stage nozzle were from 37.4 percent (10 nozzle passages - 5 per side) to a low of 6.9 percent (2 nozzle passages - 1 per side). The second stage arc of admission varied from a high of 84.4 percent (26 nozzle passages - 13 per side) to a low of 12.9 percent (4 nozzle passages - 2 per side).

Performance of the turbine at design conditions was approximately 6.7 percent higher than originally predicted, which was probably attributable to a higher predicted turbine windage loss. Effects and trends of nozzle arc of admission variation were generally as expected with the lowest performance coincident with the lowest arc of admission. In addition, large deviations from the design nozzle orientation produced the lowest performance. Turbine pressure ratio variations (1.3 to 2.0) had little effect on the overall turbine performance.

The data generated during the test program substantially verified the performance prediction methods used at Rocketdyne. Minor nozzle to nozzle angular orientation changes could be made to attain the highest performance of the MK49-F turbine.

INTRODUCTION

Partial admission turbines are used in applications such as low thrust rocket engines where low volume flow rates and flow areas in the turbines require very small blade heights for full admission (360 degree) designs. In the 15,000 lbf thrust expander cycle engine concept defined by Rocketdyne under NASA/Marshall Space Flight Center (MSFC) contract NAS8-33568, partial admission was used in the drive turbines for both the oxygen pump and the hydrogen pump (Reference 1). The turbine for the oxygen pump was a "conventional" single stage, impulse type, partial-admission design based on experimentally verified analytical codes. On the hydrogen side, a two-stage turbine with partial admission in each stage was shown by analysis to provide the highest efficiency. However, a lack of substantiating empirical data to support the analyses flagged the turbine as one of the technology issues in the hydrogen turbopump concept.

Subsequent to the engine point design effort conducted under the MSFC contract, Rocketdyne initiated company-funded detail design, analysis, and fabrication work on the major components required for the engine system. An isometric view of the high pressure hydrogen turbopump (MK49-F) resulting from this work is shown in **Figure 2**. As noted in the figure, 1,704 horsepower was required to drive the three stage pump which delivered 418 GPM at a discharge pressure of 4671 psia. In view of the lack of empirical data for the turbine, the NASA Lewis Research Center (LeRC) issued a Task Order under the Orbit Transfer Rocket Engine Technology Program (contract NAS3-23773) to experimentally determine performance and establish a data base for future designs.

Task Order scope consisted of design, fabrication and test of three two-stage partial admission turbine configurations using ambient temperature nitrogen gas as the working fluid. The three inch diameter turbine utilized the exhaust housing and rotors fabricated under the company-funded effort. Flow passages in the first and second stage nozzles aerodynamically reflected the MK49-F turbine design, but could be blocked to change the degree of admission for a given test. In addition, the second stage nozzle could be circumferentially rotated during a given test to determine the effects of second stage nozzle angular orientation on turbine performance. Results of the Task Order effort are reported herein.

MARK 49 LH₂ TURBOPUMP

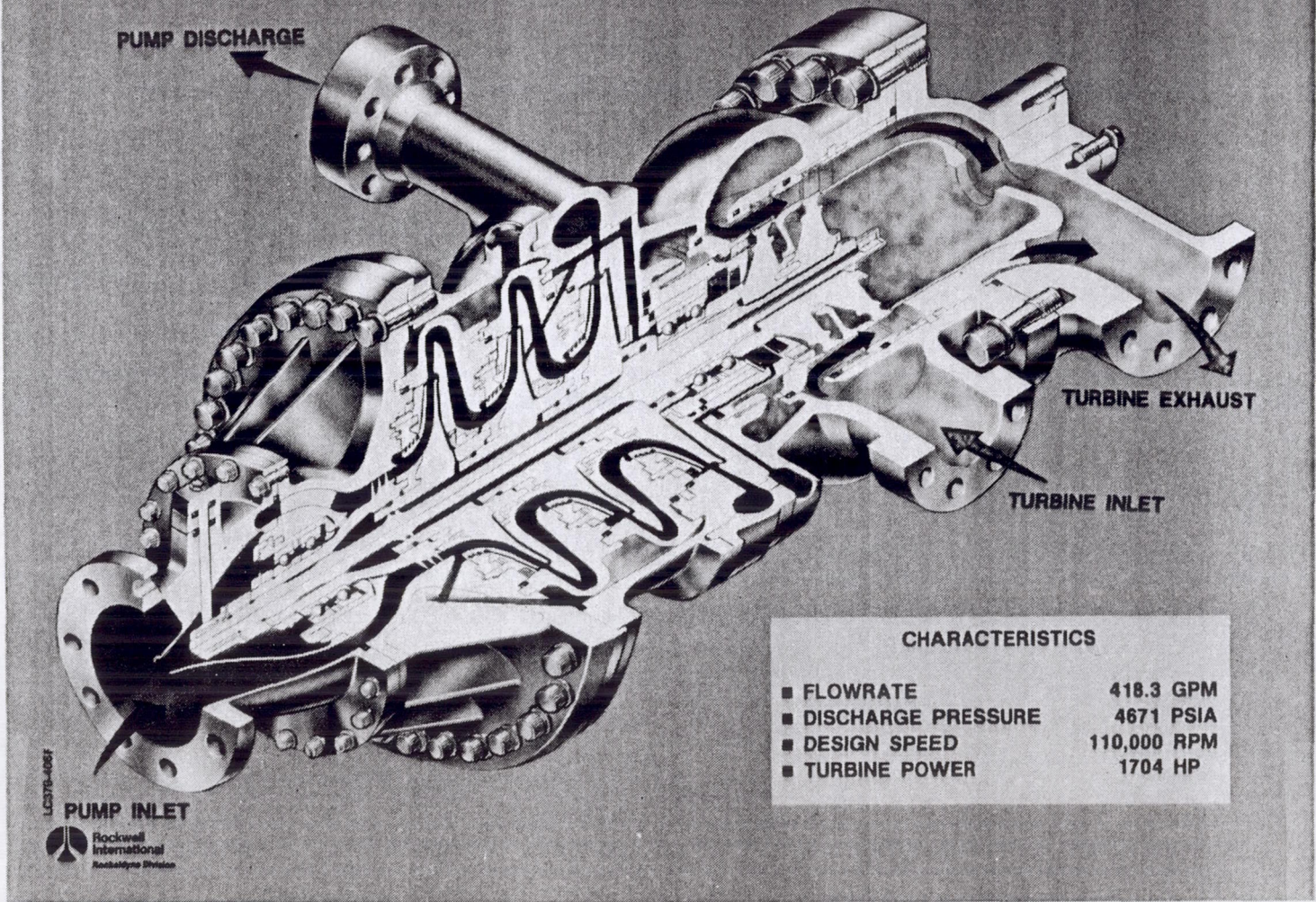

Figure 2

OBJECTIVES

The overall objectives of this program were to (1) verify the two stage partial-admission turbine analytical predictions by conducting laboratory tests using ambient (room) temperature gaseous nitrogen, (2) update analytical performance prediction methods for future designs of similar low thrust engine turbines, and (3) provide baseline data for comparison with the OTV MK49-F turbine for possible performance enhancements with only minor hardware modifications.

The technical approach to reduce cost was to use all available MK49-F turbine hardware, such as the turbine and exhaust housing, and design most of the other tester hardware using aluminum material to minimize design and fabrication complexities.

TECHNICAL DISCUSSION

MK49-F TURBINE DESIGN

Design requirements for the MK49-F turbine were derived from the cycle power balance for the engine and are shown in **Table 1**. The turbine speed of 110,000 rpm was set based on optimization of the hydrogen pump performance. The working fluid was hydrogen gas at a flow rate of 3.73 lbm/sec with a total pressure and total temperature at the inlet flange of 3830 psia and 881 degrees Rankine, respectively. Total pressure at the turbine outlet flange was 2173 psia.

Table 1. Design Requirements for the MK49-F Turbine

Working fluid	Gaseous Hydrogen
Power output, hp	1,704
Speed, rpm	110,000
Flowrate, lb/sec	3.73
Inlet flange total temperature, R	881
Inlet flange total pressure, psia	3,830
Outlet flange total pressure, psia	2,173
Pressure ratio	1.763
Specific work, btu/lb	323
Efficiency, percent	63.6

The MK49-F turbine was designed assuming an equal available energy split between stages. Design point pressures and temperatures at the blade path mean diameter are shown in **Figure 3**. Design point velocity diagrams at the mean diameter are shown in **Figure 4**. The turbine inlet manifold total pressure loss was set at 5 percent of the flange-to-flange total pressure drop resulting in a first stage nozzle inlet total pressure of 3,747 psia. The first stage rotor exit absolute velocity pressure was 3 percent of the overall total pressure drop and 25 percent of that was considered available to the second stage. The outlet manifold total pressure loss was set equal to the second stage rotor outlet absolute velocity pressure.

A cross-sectional view of the turbine is shown in **Figure 5**. The rotor blades were shrouded to reduce tip clearance loss. Shroud operating radial clearance was 0.005 inch for each stage. A close clearance interstage seal under the second stage nozzle provided

low bypass nozzle leakage and also served as a rotordynamic stabilizing factor. Blade path design data are given in **Figure 6**. The nozzle and rotor blade height for each row was constant from inlet to outlet. Rotor blade heights overlapped the nozzle outlet heights and were set to provide the flow area requirements for the gas at the outlet of the respective nozzle arc of admission. The axial space between the nozzle trailing edge and rotor leading edge for each stage was set at 0.05 inches to minimize nozzle outlet flow spillage into the axial space with the associated energy loss at the end of the arc of admission. The axial space between the first stage rotor trailing edge and the second stage nozzle leading edge was set at 0.20 inches to minimize circumferential gradients into the second stage. The benefit of a large axial space between stages was reported in Reference 2 from tests of a two stage turbine with a partial admission first stage and a full admission second stage. Two admission arcs spaced 180 degrees apart were used in each nozzle. Total admission fractions were 0.345 (5 passages per arc) and 0.452 (7 passages per arc) for stage 1 and stage 2, respectively. The circumferential position of the second stage nozzle center relative to the first stage nozzle center was set at 40 degrees in the direction of rotation (**Figure 7**) such that the absolute velocity vector from the first stage rotor would discharge directly into the second stage nozzle.

Blade shapes and blade profile coordinates were defined at the mean diameter and are presented in **Figure 8**. Non-twisted, constant section blading was used because the blade heights were small and previous Rocketdyne designs with similar constant section and small height demonstrated high performance. As noted in **Figure 6**, prime numbers were selected for the number of rotor blades (53 first stage, 59 second stage) in order to minimize blade frequency problems.

Predicted design and off-design performance and flow characteristics for the MK49-F turbine are shown in **Figure 9**. At the design point velocity ratio of 0.286, an efficiency of 63.6 percent was predicted.

BLADE PATH MEAN STATE CONDITIONS AT DESIGN

MK 49-F TURBINE

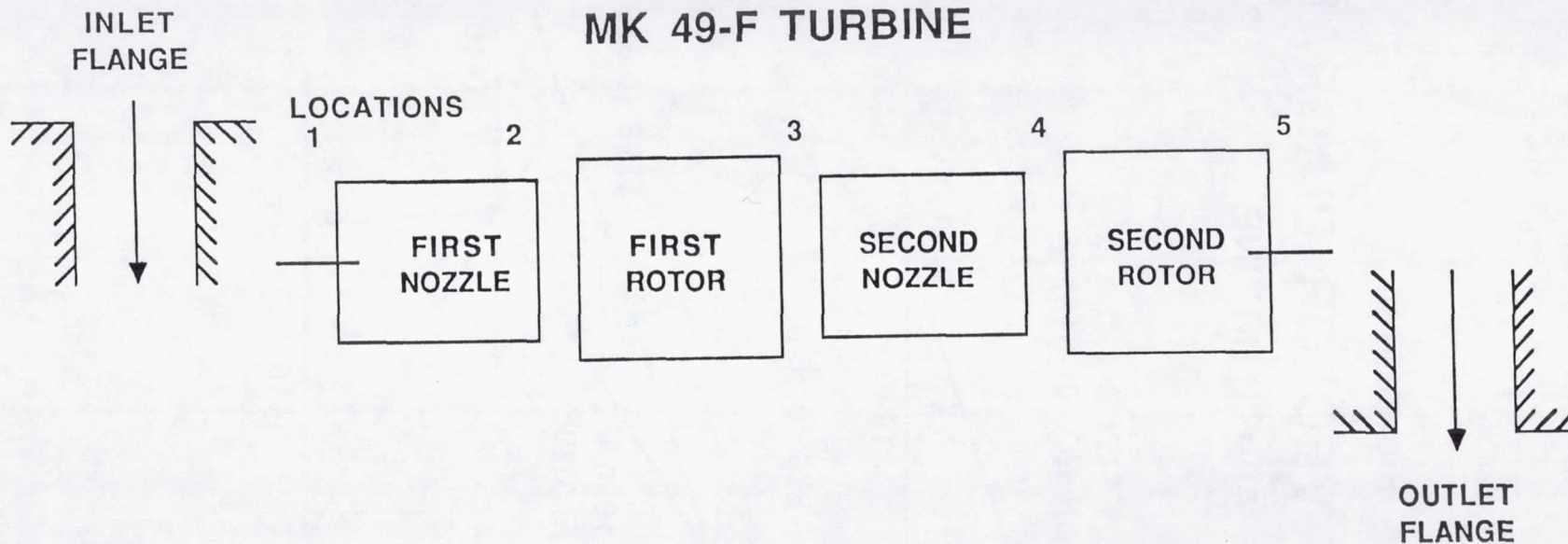

LOCATION	IN. FLG.	1	2	3	4	5	OUT. FLG.
PRESSURES, PSIA							
TOTAL	3830	3747	---	---	---	---	2173
STATIC	---	---	2896	2859	2200	2173	---
TEMPERATURE, R							
TOTAL	881	881	---	---	---	---	799
STATIC	---	---	825	830	777	783	---

Figure 3



Rockwell
International
Rocketdyne Division

0920/S/ca

NASA CR-179548
R/RD 86-214

Figure 4
VELOCITY VECTOR DIAGRAM
MK 49-F TURBINE

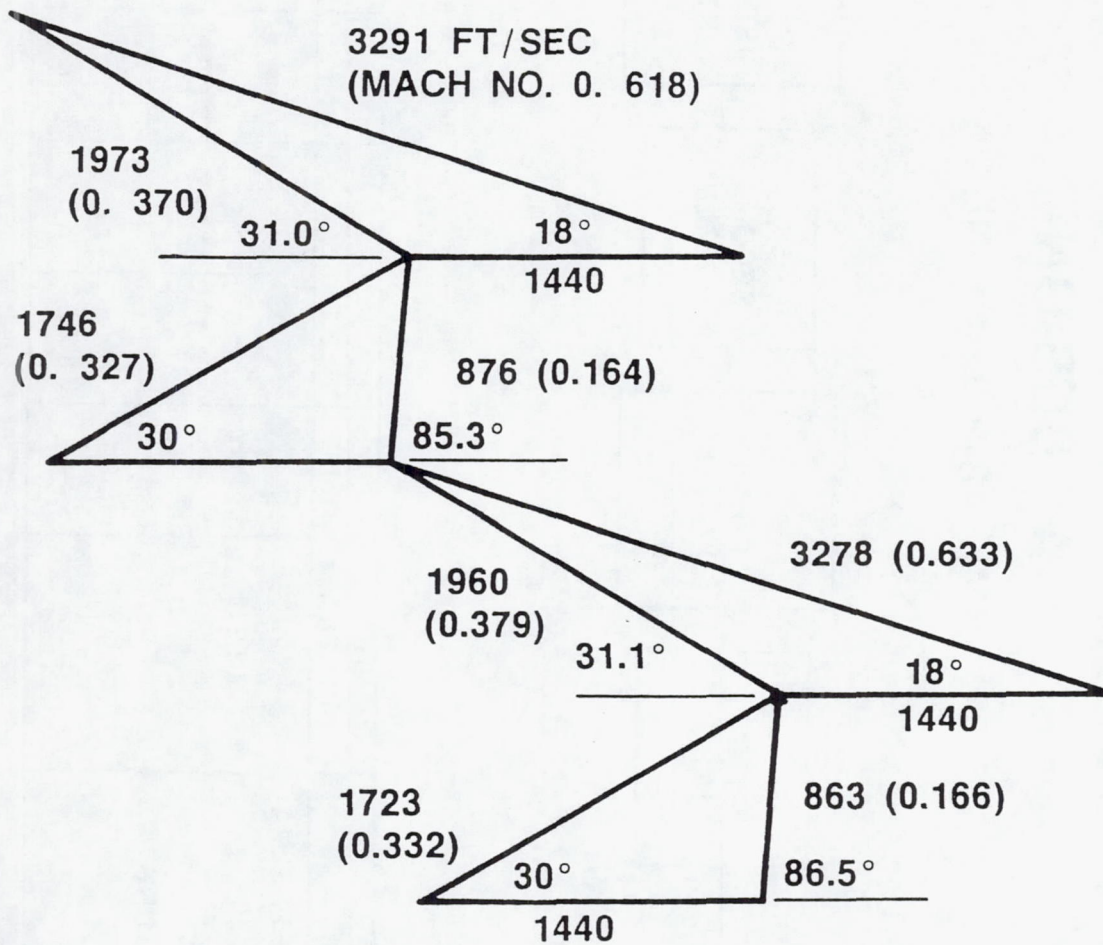

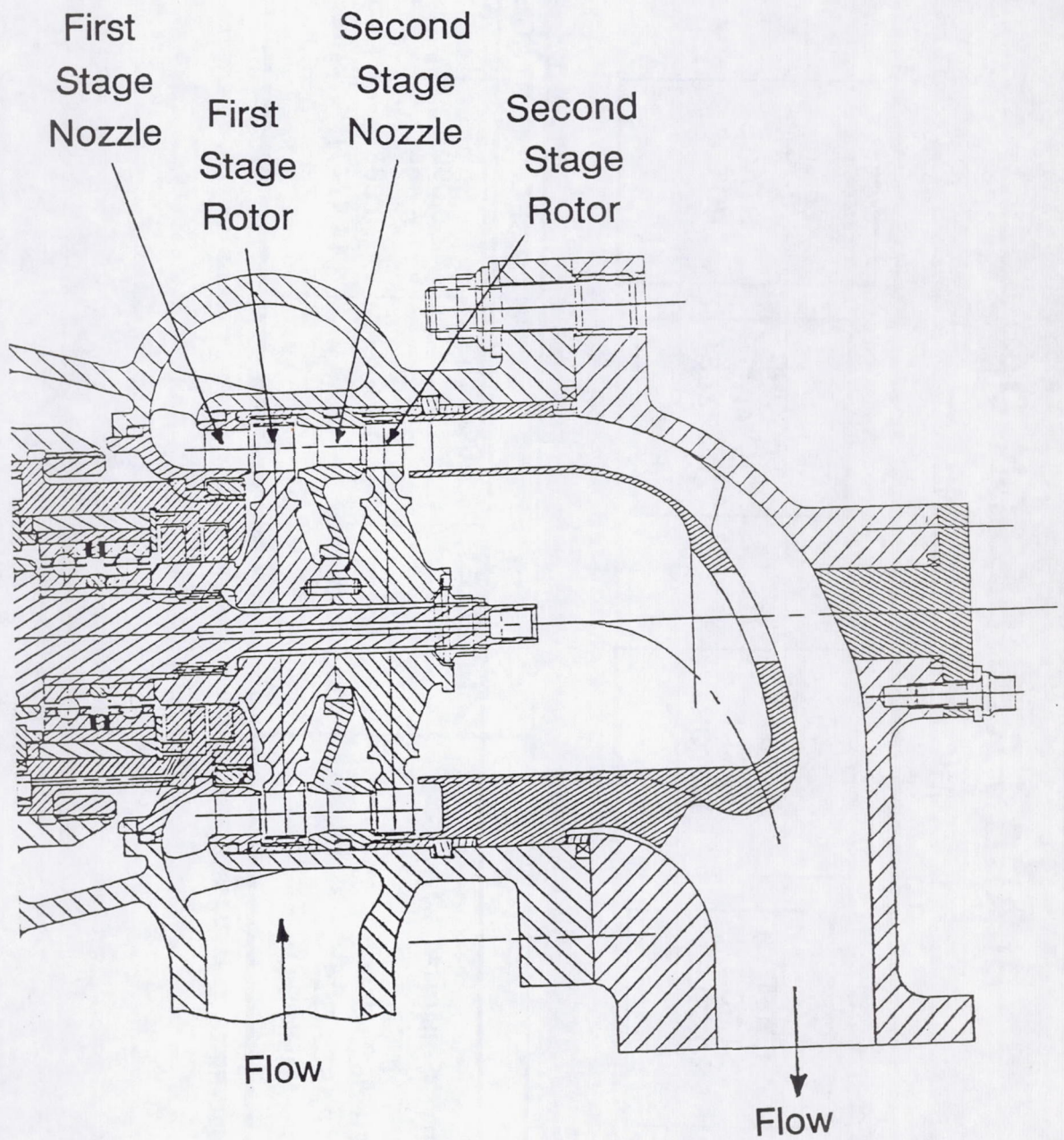
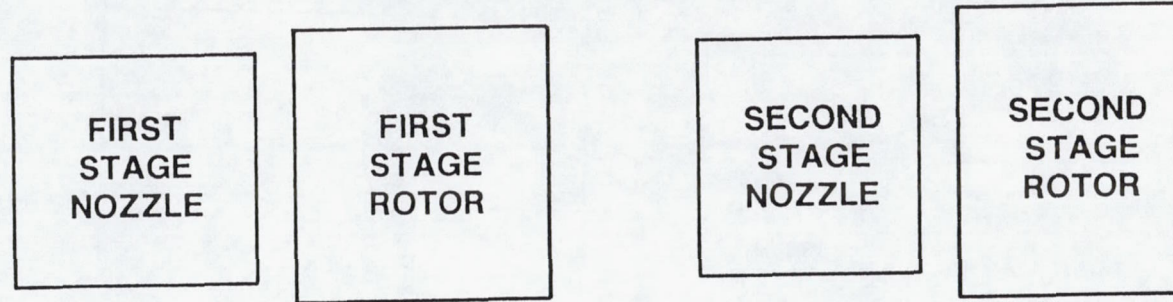

Figure 5 MK49-F Turbine Cross Section

Figure 6

BLADE PATH DESIGN DATA

MK 49-F TURBINE



STAGE	FIRST STAGE		SECOND STAGE	
	NOZZLE	ROTOR	NOZZLE	ROTOR
ELEMENT	3.000	3.000	3.000	3.000
MEAN DIAMETER, INCH	0.316	0.366	0.298	0.367
BLADE HEIGHT, INCH	0.381	0.340	0.368	0.310
NUMBER OF PASSAGES	10 (5+5)*	53	14 (7+7)**	59
FRACTION OF ADMISSION	0.345		0.452	

*29 VANES FULL RING; **31 VANES FULL RING

Figure 7 First and Second Stage Nozzle Angular Orientation
MK 49-F TURBINE

DESIGN SECOND NOZZLE INLET CIRCUMFERENTIAL DISPLACEMENT
= 40 DEGREES IN DIRECTION OF ROTATION

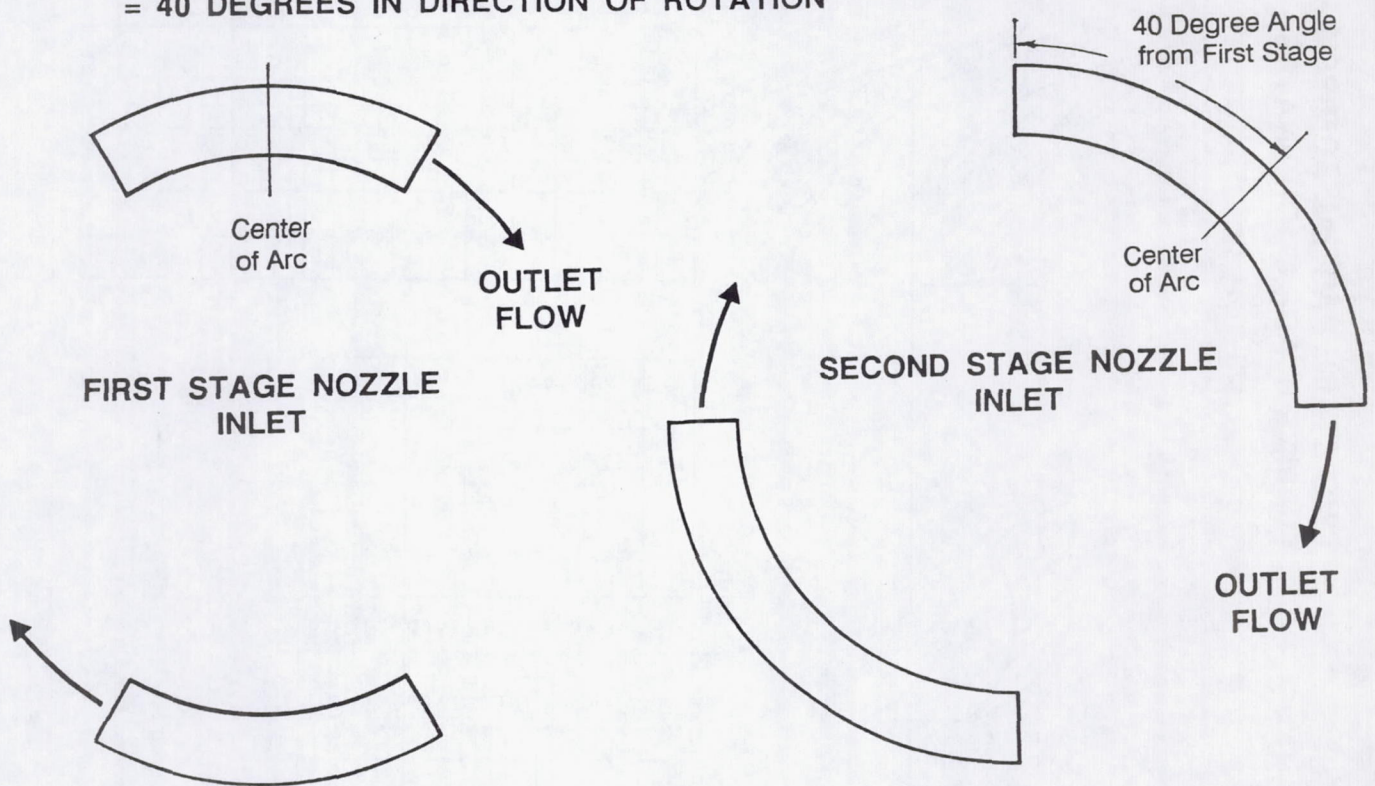

TWO STAGE PARTIAL ADMISSION TURBINE BLADE COORDINATES

Figure 8

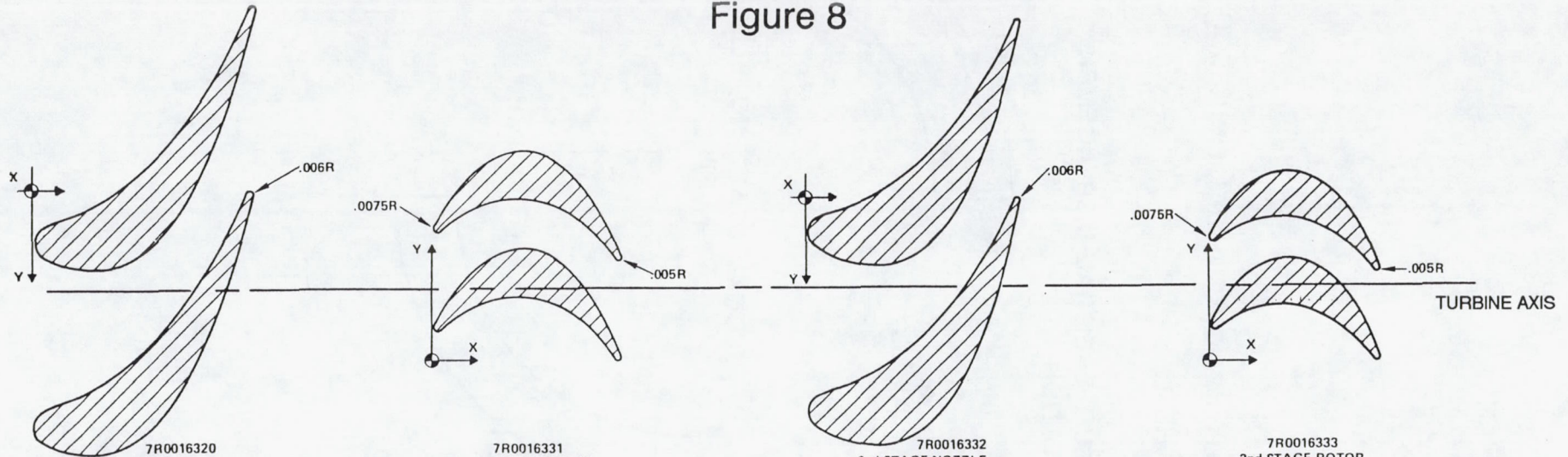

7R0016320
1st STAGE NOZZLE

STATION	X, IN	Y, IN
1	0.0000	0.4210
2	0.0037	0.4214
3	0.0117	0.4440
4	0.0187	0.4493
5	0.0468	0.4606
6	0.0760	0.4667
7	0.1052	0.4683
8	0.1345	0.4642
9	0.1637	0.4536
10	0.1929	0.4349
11	0.2222	0.4069
12	0.2455	0.3764
13	0.2689	0.3376
14	0.2865	0.3025
15	0.3040	0.2616
16	0.3215	0.2145
17	0.3391	0.1606
18	0.3566	0.0996
19	0.3683	0.0552
20	0.3798	0.0074
21	0.3800	0.0058
22	0.3783	0.0017
23	0.3742	0.0000
24	0.3700	0.0018
25	0.3687	0.0037
26	0.3566	0.0332
27	0.3391	0.0719
28	0.3215	0.1068
29	0.3040	0.1384
30	0.2865	0.1672
31	0.2689	0.1935
32	0.2455	0.2251
33	0.2222	0.2533
34	0.1929	0.2842
35	0.1637	0.3108
36	0.1345	0.3335
37	0.1052	0.3526
38	0.0760	0.3683
39	0.0468	0.3808
40	0.0187	0.3927
41	0.0117	0.3980
42	0.0048	0.4059

7R0016331
1st STAGE ROTOR

STATION	X, IN	Y, IN	STATION	X, IN	Y, IN
1	0.0000	0.0569	26	0.3387	0.0017
2	0.0060	0.0701	27	0.3346	0.0000
3	0.0190	0.0922	28	0.3308	0.0023
4	0.0320	0.1113	29	0.3128	0.0272
5	0.0450	0.1281	30	0.2946	0.0476
6	0.0580	0.1430	31	0.2764	0.0644
7	0.0709	0.1563	32	0.2583	0.0782
8	0.0851	0.1693	33	0.2401	0.0894
9	0.1001	0.1809	34	0.2220	0.0983
10	0.1152	0.1898	35	0.2038	0.1051
11	0.1302	0.1958	36	0.1857	0.1097
12	0.1452	0.1991	37	0.1675	0.1124
13	0.1603	0.2002	38	0.1502	0.1130
14	0.1775	0.1988	39	0.1359	0.1123
15	0.1954	0.1936	40	0.1216	0.1106
16	0.2134	0.1849	41	0.1072	0.1076
17	0.2313	0.1728	42	0.0929	0.1033
18	0.2492	0.1567	43	0.0786	0.0975
19	0.2670	0.1352	44	0.0642	0.0902
20	0.2795	0.1167	45	0.0499	0.0814
21	0.2921	0.0967	46	0.0356	0.0710
22	0.3046	0.0753	47	0.0212	0.0592
23	0.3171	0.0524	48	0.0106	0.0500
24	0.3296	0.0278	49	0.0045	0.0500
25	0.3399	0.0061			

7R0016332
2nd STAGE NOZZLE

STATION	X, IN	Y, IN
1	0.0000	0.3635
2	0.0049	0.3811
3	0.0135	0.3907
4	0.0245	0.3982
5	0.0491	0.4090
6	0.0797	0.4184
7	0.1104	0.4224
8	0.1411	0.4200
9	0.1717	0.4098
10	0.2024	0.3902
11	0.2269	0.3662
12	0.2515	0.3336
13	0.2760	0.2906
14	0.2944	0.2507
15	0.3128	0.2032
16	0.3312	0.1473
17	0.3435	0.1050
18	0.3557	0.0586
19	0.3678	0.0076
20	0.3680	0.0061
21	0.3662	0.0018
22	0.3619	0.0000
23	0.3576	0.0018
24	0.3562	0.0038
25	0.3435	0.0335
26	0.3312	0.0692
27	0.3128	0.0936
28	0.2944	0.1239
29	0.2760	0.1509
30	0.2515	0.1827
31	0.2269	0.2106
32	0.2024	0.2347
33	0.1717	0.2608
34	0.1411	0.2827
35	0.1104	0.3009
36	0.0797	0.3157
37	0.0491	0.3273
38	0.0245	0.3364
39	0.0147	0.3408
40	0.0062	0.3487

7R0016333
2nd STAGE ROTOR

STATION	X, IN	Y, IN	STATION	X, IN	Y, IN
1	0.0000	0.0575	26	0.3099	0.0059
2	0.0039	0.0715	27	0.3088	0.0018
3	0.0131	0.0906	28	0.3049	0.0000
4	0.0224	0.1050	29	0.3011	0.0019
5	0.0317	0.1171	30	0.2837	0.0221
6	0.0410	0.1276	31	0.2663	0.0399
7	0.0503	0.1371	32	0.2488	0.0551
8	0.0596	0.1454	33	0.2313	0.0677
9	0.0712	0.1546	34	0.2139	0.0777
10	0.0844	0.1637	35	0.1964	0.0854
11	0.0977	0.1710	36	0.1789	0.0909
12	0.1109	0.1763	37	0.1614	0.0945
13	0.1242	0.1795	38	0.1440	0.0964
14	0.1374	0.1808	39	0.1277	0.0968
15	0.1551	0.1799	40	0.1157	0.0964
16	0.1739	0.1760	41	0.1036	0.0952
17	0.1927	0.1685	42	0.0916	0.0931
18	0.2115	0.1567	43	0.0796	0.0901
19	0.2303	0.1403	44	0.0676	0.0858
20	0.2490	0.1194	45	0.0555	0.0804
21	0.2595	0.1055	46	0.0435	0.0738
22	0.2700	0.0896	47	0.0315	0.0661
23	0.2805	0.0714	48	0.0194	0.0573
24	0.2909	0.0507	49	0.0101	0.0504
25	0.3014	0.0274	50	0.0043	0.0507

Figure 9
PERFORMANCE CHARACTERISTICS
MARK 49-F TURBINE

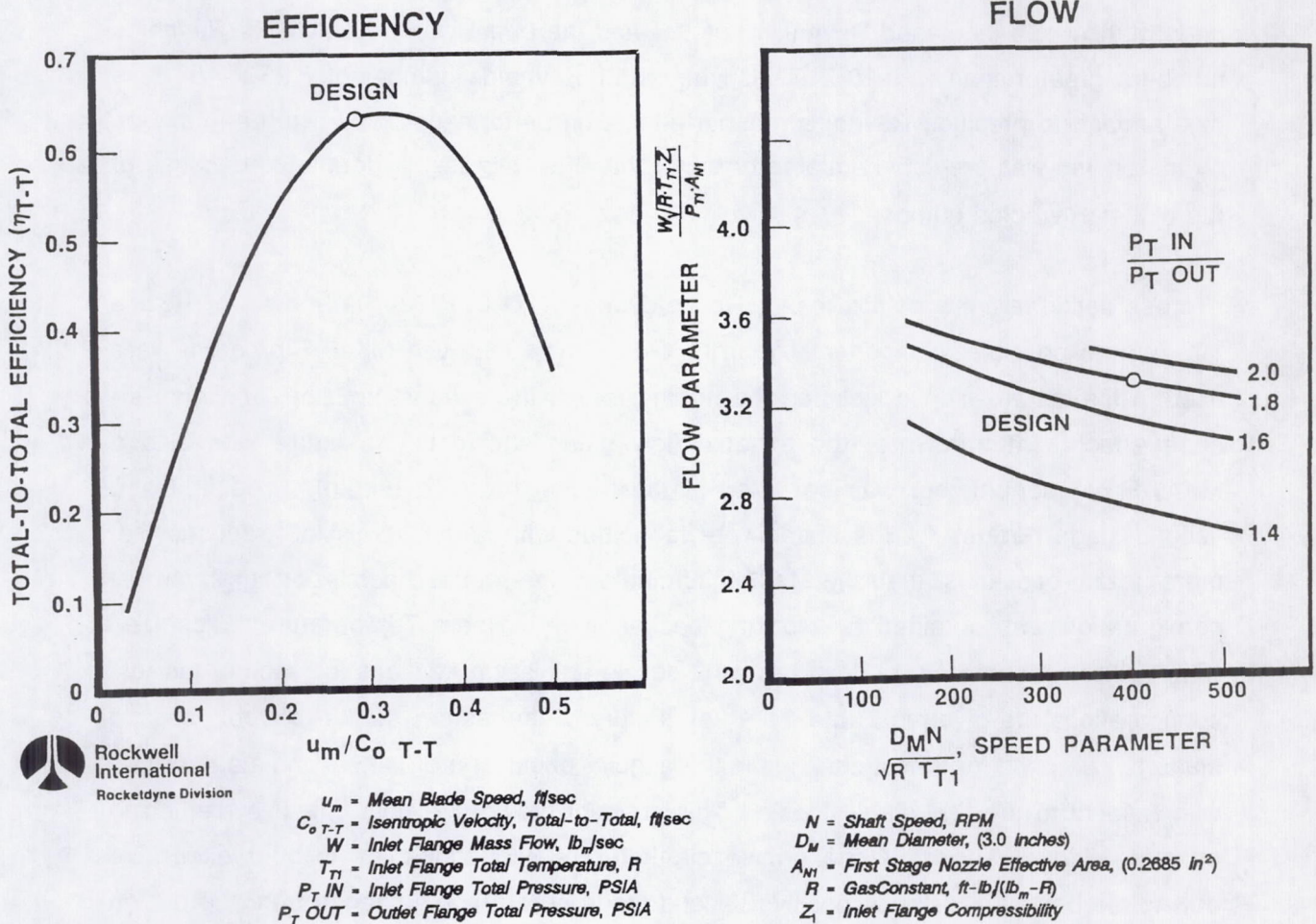

TESTER DESIGN AND DESCRIPTION

In order to provide a comprehensive data base for future designs, program scope included gaseous nitrogen testing of a full-scale model of the MK49-F turbine plus two additional configurations with smaller admission fractions. Design point parameters for the MK49 -F turbine are listed in **Table 2** along with standard air equivalent conditions as defined in **Appendix A**. Also presented are speed, flow rate and pressure ratio magnitudes that simulate MK49-F turbine design point operation in the tester with nitrogen gas as the working fluid at representative test inlet conditions. Note in **Table 2** that the Reynolds number of the MK49-F turbine was not duplicated in the tester. In Reference 3, the effect of Reynolds number on turbine performance was increased performance with increased Reynolds number and the effect was negligible for Reynolds numbers greater than 2×10^5 . Thus, the tester Reynolds number of 8.05×10^5 was high enough to preclude Reynolds number effects on performance. Turbine performance on the engine was predicted equal to or better than the GN₂ test performance because of the higher Reynolds number.

A cross sectional view of the tester, Rocketdyne P/N 7R0017780, is shown in **Figure 10**. Where possible, components from the Rocketdyne in-house MK49-F program were used in the tester. These included the turbine rotors, the exhaust housing, and rotor-to-shaft attachment hardware (the exhaust flow guide shown in the figure was also a MK49-F component, but was not used in the testing reported herein). The first and second stage nozzles for the tester were fabricated with larger admission fractions (i.e. more nozzle passages) than the MK49-F turbine and the required admission for each test configuration was obtained by blocking passages with Room Temperature Vulcanized (RTV) silicon rubber. Stage 1 and stage 2 nozzle admission fractions for each of the test configurations are given in **Table 3**. A key feature of the tester was the rotatable second stage nozzle used for in-test changes in the angular orientation of the second stage nozzle with respect to the first stage nozzle. This concept provided a cost effective method to evaluate first to second stage nozzle circumferential relationships without excessive down time between tests. A positive second stage nozzle angle change from the design position was opposite the direction of rotor rotation. The tester was also built with two quartz windows to provide capability for laser velocimeter viewing of the flow at the inlet of the second stage nozzle. However, tests using the velocimeter were not conducted because of a reduction in Task Order scope. Polyimide turbine tip shroud and interstage seals were used in the tester to prevent damage to the MK49-F turbine rotors in the event of a rub. The tester parts list is shown in **Table 4**.

Table 2
MK49-F TURBINE/TESTER DESIGN PARAMETERS

PARAMETER		HYDROGEN GAS	STANDARD AIR EQUIVALENT CONDITIONS	TESTER
				NITROGEN GAS REPRESENTATIVE TEST CONDITIONS
SPECIFIC HEAT	$\frac{\text{BTU}}{\text{LBM } ^\circ\text{R}}$	3.534	0.240	0.256
SPECIFIC HEAT RATIO		1.409	1.400	1.432
GAS CONSTANT	$\frac{\text{FT-LBF}}{\text{LBM } ^\circ\text{R}}$	766.4	53.345	55.164
COMPRESSIBILITY FACTOR		1.107	1.000	0.994
NOZZLE INLET TOTAL PRESSURE	PSIA	3747	14.696	215
INLET MANIFOLD TOTAL TEMPERATURE	$^\circ\text{R}$	881	518.7	480
PRESSURE RATIO		1.725	1.721	1.735
FLOW RATE	$\frac{\text{LBM}}{\text{SEC}}$	3.73	.0746	1.128
SPEED	RPM	110,000	21,144	20,711
REYNOLDS NUMBER		34.5 X 10 ⁵		8.05 X 10 ⁵

$$Re = \frac{12 W}{V_m \mu}$$

$W = \text{Flow Rate, } \frac{\text{LBM}}{\text{SEC}}$
 $V_m = \text{Mean Radius, In.}$
 $\mu = \text{Viscosity, LBM / (ft-sec)}$

RamIn 6/8/92 TH/jm-2

Figure 10
**TWO-STAGE PARTIAL-ADMISSION
 TURBINE TESTER**

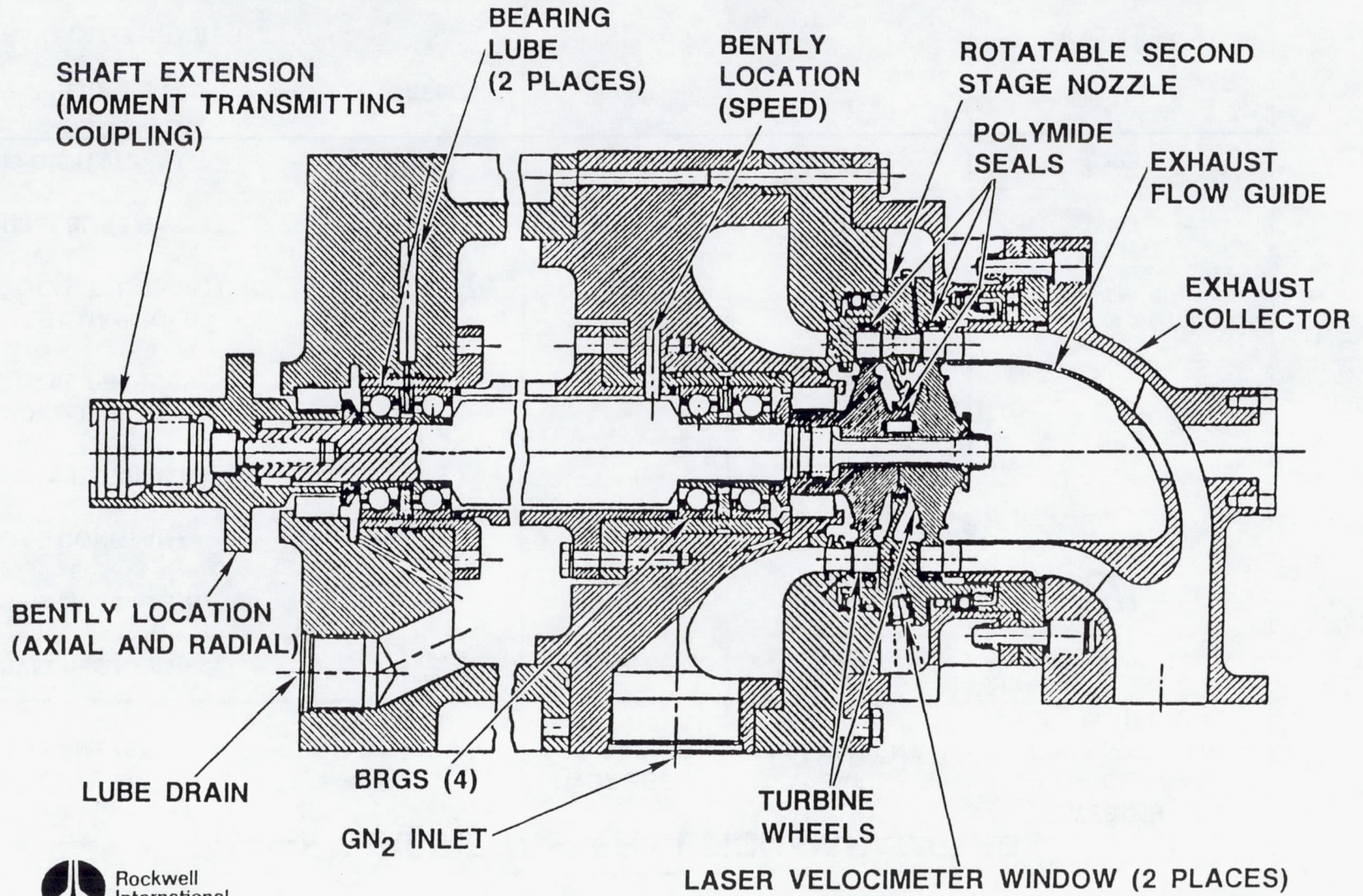

- 18 -

Table 3
NOZZLE ADMISSION FRACTIONS

TEST CONFIGURATION	STAGE 1 NOZZLE ADMISSION FRACTION NO. OF OPEN PASSAGES	STAGE 2 NOZZLE ADMISSION FRACTION NO. OF OPEN PASSAGES
"DESIGN" (MK-49F)	.345 10 (5 EACH ARC)*	.452 14 (7 EACH ARC)
"HALF-DESIGN"	.138 4 (2 EACH ARC)	.194 6 (3 EACH ARC)
"QUARTER-DESIGN"	.069 2 (1 EACH ARC)	.129 4 (2 EACH ARC)

* ARCS OF ADMISSION ARE 180° APART

STAGE 1 NOZZLE BASED ON 29 PASSAGES FOR FULL ADMISSION AND WAS FABRICATED WITH 14 PASSAGES (7 EACH ARC).

STAGE 2 NOZZLE BASED ON 31 PASSAGES FOR FULL ADMISSION AND WAS FABRICATED WITH 26 PASSAGES (13 EACH ARC).

Ramin 6/8/92 TH/jm-3

Table 4 TURBINE TEST PARTS LIST

DRAWING NO.	PART NAME	DRAWING NO.	PART NAME
FBG190-06-3.0-4.5	PROXIMITOR, BENTLY	7R0017759-3, -5	SLEEVE AND NUT, TARE TEST
-36-02	PROXIMITOR, BENTLY	7R0017760	LOCK, CUP
M204BJHX2	20MM BRG, TURBINE SHAFT	7R0017761	SHAFT 2 STAGE PARTIAL ADMI. TURBINE
NAS558-606-10	KEY COUPLING	7R0017762	SPACER, BEARING INNER RACE
1-1318-2	SEAL, FACE, COUPLING END	7R0017763	SPRING BEARING PRELOAD (100#)
5-9-BO-07-BG-19	SEAL, FACE TURBINE END	7R0017764	SPACER, 2ND STAGE NOZZLE
NSH12RGB2150-10BOG	GEAR MOTOR AND CONTROL UNIT	7R0017765	SPACER, BRG OUTER RACE
YA40	GEAR, PINON (2 INCH DIAMETER)	7R0017766-3	RETAINER, BRG OUTER RACE
YA120	GEAR, (6 INCH DIAMETER)	7R0017767	COUPLING, QUILL (MODIFIED)
SBB 3TAF64-72P	BEARING, NOZZLE ANGULATION	7R0017768	BOLT, SHAFT EXT (NAS1315-6-14)
1604-116-500	LEBOW TORQUEMETER (500)	7R0017769	QUILL, POWER ABSORBER (MODIFIED)
1604-116-100	LEBOW TORQUEMETER (100)	7R0017770-3	SLEEVE, BEARING, COUPLING END
7540-105	LEBOW SIGNAL COND.	7R0017771	SPACER SEAL
R0012814	COUPLINGS, QUILL	7R0017772-3	EXTENSION SHAFT
EWR524025	QUILL, POWER ABSORBER (R0012816)	7R0017773-3	RING, MATING
7R0015027	SPACER	7R0017774-3	HOUSING, REAR BEARING
7R0016309	COVER, EXHAUST HOUSING	7R0017775-3	SLEEVE, BEARING
7R0016327-3	NUT, TURBINE	7R0017776	INLET, TURBINE
7R0016328-3	LOCK, TURBINE NUT	7R0017777	SPACER, SHAFT EXTENSION
7R0016331	WHEEL, 1ST STAGE, TURBINE	7R0017778	NOZZLE, FIRST STAGE
7R0016333	WHEEL, 2ND STAGE TURBINE	7R0017779	NOZZLE, SECOND STAGE
7R0016356	HOUSING, TURBINE EXHAUST	7R0017780	ASSY, 2-STAGE PARTIAL ADMI. TURBINE
7R0016357	GUIDE, FLOW, TURBINE EXHAUST	NAS 1081C3A4	SCREW
7R0017741	ORIFICE, LUB BEARING	NAS 1351N6-14	SCREW
7R0017742-3	HOUSING, 2ND STAGE NOZZLE	NAS 1081C4A4	SCREW
7R0017743	SPACER, 2ND STAGE NOZZLE BEARING	NAS 558-606-10	KEY
7R0017744	NUT, BRG, RETAINER 2ND STAGE NOZZLE	MS 9501-014	BOLT
7R0017745-3	LOCK, NUT, BRG RET, 2ND STAGE NOZZLE	MS 15795-809	WASHER
7R0017746	RETAINER, 2ND STAGE NOZZLE BEARING	MS 9490-014	BOLT
7R0017747	WINDOW, VELOCIMETER	MS 9581-10	WASHER
7R0017748	SCREW, WINDOW RETAINING	MS 9490-020	BOLT
7R0017749	PLUG, WINDOW	MS 9501-030	BOLT
7R0017750	STAND, LASER ASSY	MS 9501-023	BOLT
7R0017751	EXHAUST, DUCT, STRAIGHT	MS 9500-06	BOLT
7R0017752	SPRING, BEARING PRELOAD (200#)	MS 9321-09	WASHER
7R0017753	PLATE, ADAPTER	SP-211 B	VESPEL BAR, 1.75 DIA X 2.5
7R0017754	GEAR SECTOR (MODIFIED)	SP-211 D	VESPEL DISK, 5 DIA X .75
7R0017755	RING, BOLT	MISC.	O-RINGS
7R0017756	SET SCREW, EXHAUST GUIDE	MISC.	PRESSURE TUBING (.040X.008)
7R0017757-1	BRACKET, GEAR MOTOR		
7R0017758	PINON, GAR MOTOR (MODIFIED)		

NASA CR-179548
 R/RD 86-214

Photographs of the first stage nozzle, the MK49-F turbine wheels, and the second stage nozzle are presented in **Figure 11**. Note that **Figure 11** is a composite of individual photographs which were taken at different object distances (approximate scales are shown above the component photos). **Figure 12** is a photograph of all the tester components. **Figure 13** is a closeup photograph showing the second stage nozzle angular orientation motor drive setup and the instrumentation tube bundles emanating from the nozzle housing.

ROTORDYNAMIC ANALYSIS

The two stage partial admission turbine tester was analyzed from a rotordynamic standpoint to determine the rotor critical speeds, stability, and response to unbalance forces. Following an iterative process, analysis indicated that a tester design with a 1.45 inch shaft diameter between duplex bearing sets could adequately meet the design criteria of operation outside of the 20% critical speed margin. Response analysis indicated low steady-state bearing loads and rotor displacements during operation. Stability analysis showed the rotor to be stable to speeds greater than the operating speed range.

A detailed finite element model was developed which represented the stiffness, mass, and geometric properties of the rotor. **Figure 14** presents a diagram of the rotor corresponding load path.

Damped natural frequencies and corresponding mode shapes were calculated. Results are shown in **Figures 15** through **17**. These curves represent the rotor critical speeds with damping and cross-coupling forces present as well as turbine Alford forces. Observing **Figure 15**, at a speed of 31,000 RPM, the nearest rotor critical speed occurred at 47,747 RPM. This resulted in a 35% separation of the maximum operating speed from the rotor first critical.

Since the seals on the turbine tester produced destabilizing cross-coupling forces, the turbine tip Alford forces were expected to be present, therefore the possibility for unstable rotor whirl to develop existed. For this reason, a stability analysis was conducted. The results of the analysis showed that the rotor was stable for all speeds analyzed. This was the expected result since the rotor operated below its lowest critical speed.

Figure 11 First and Second Stage Nozzle Turbine Wheels

3"

FIRST-STAGE NOZZLE

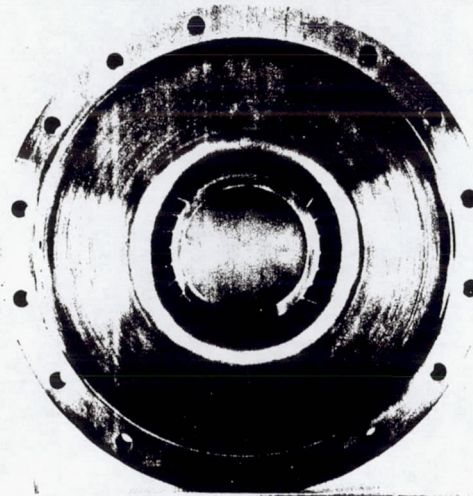

INLET

3"

TURBINE WHEELS

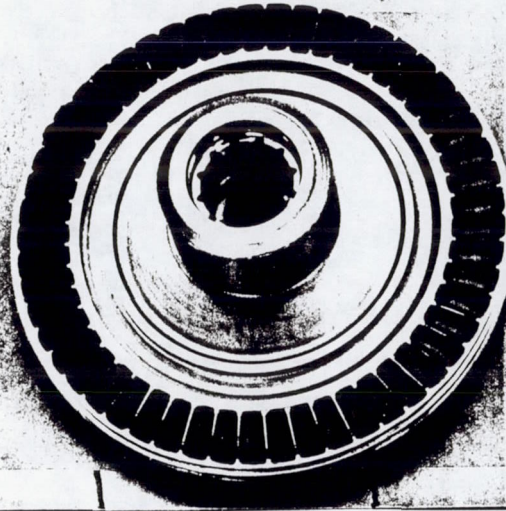

FIRST STAGE

3"

SECOND-STAGE NOZZLE

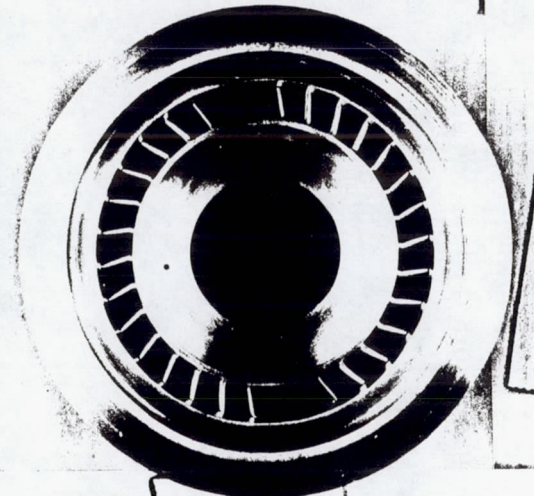

INLET

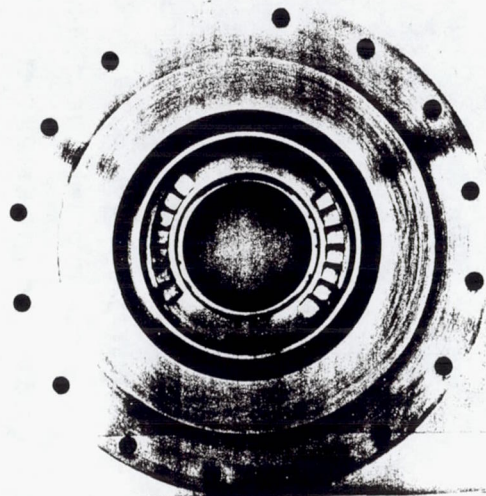

DISCHARGE

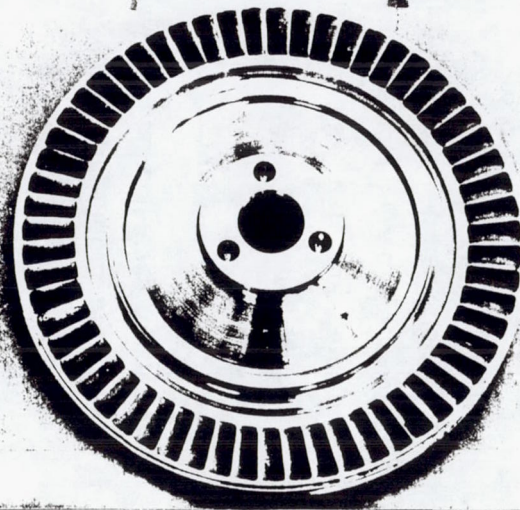

SECOND STAGE



DISCHARGE

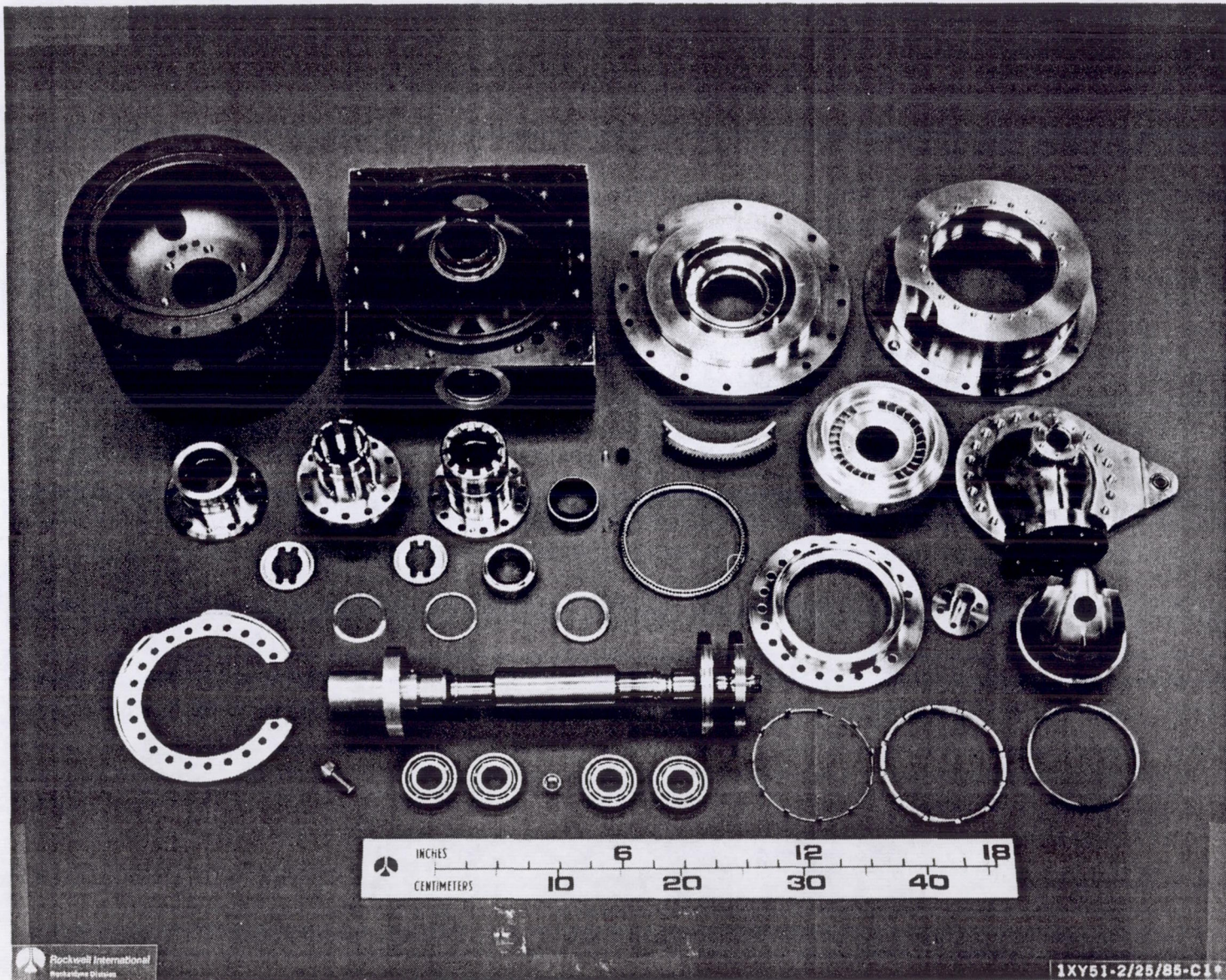
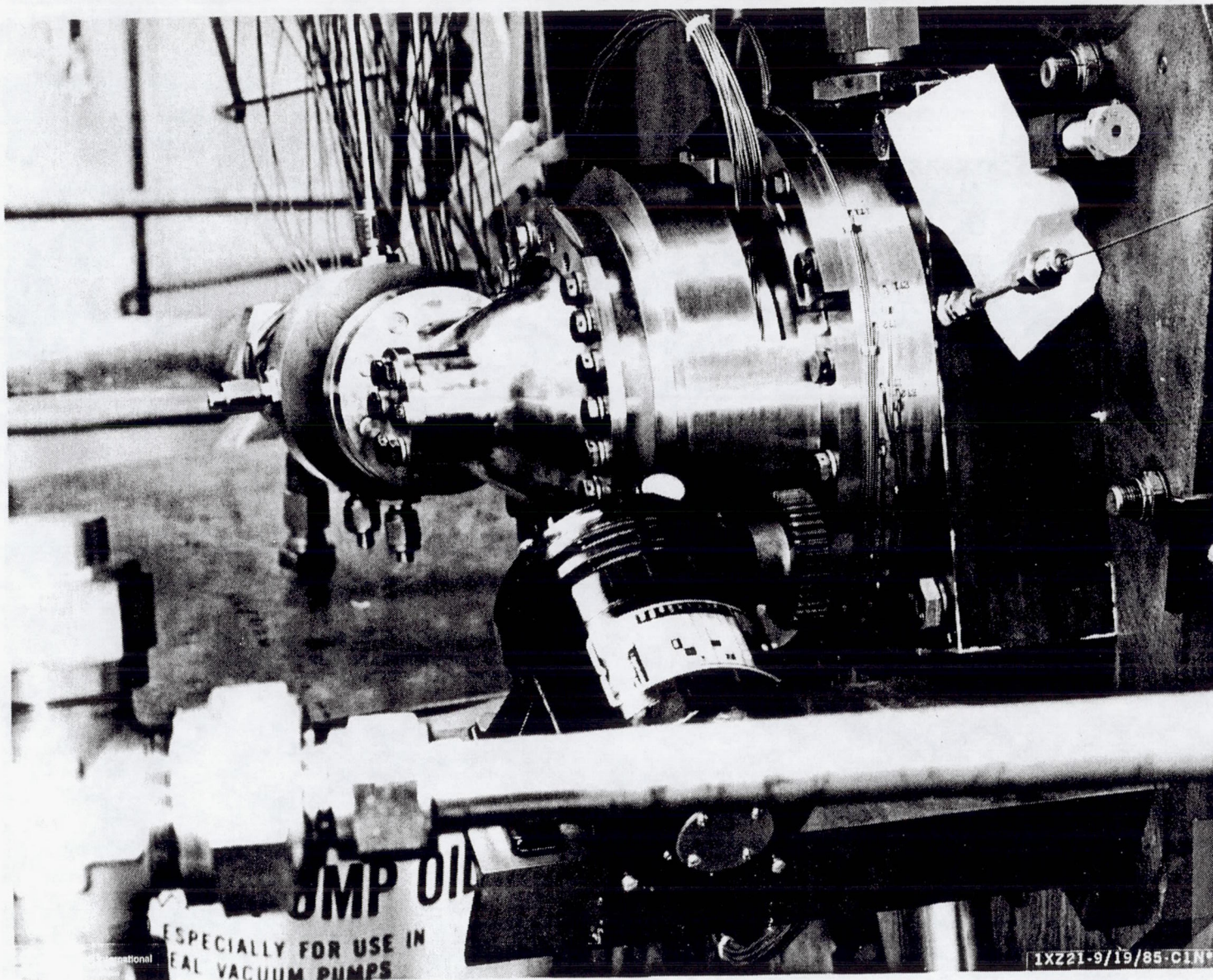

Figure 12 Tester Components

Figure 13 Second Stage Nozzle Angular Orientation Motor Drive Setup



NASA CR-179548
R/IRD 86-214

Figure 14
 Load Path Diagram
 MK49-F Turbine Tester
 Rotating Assembly Model

material 1 - Aluminum
 material 2 - Steel

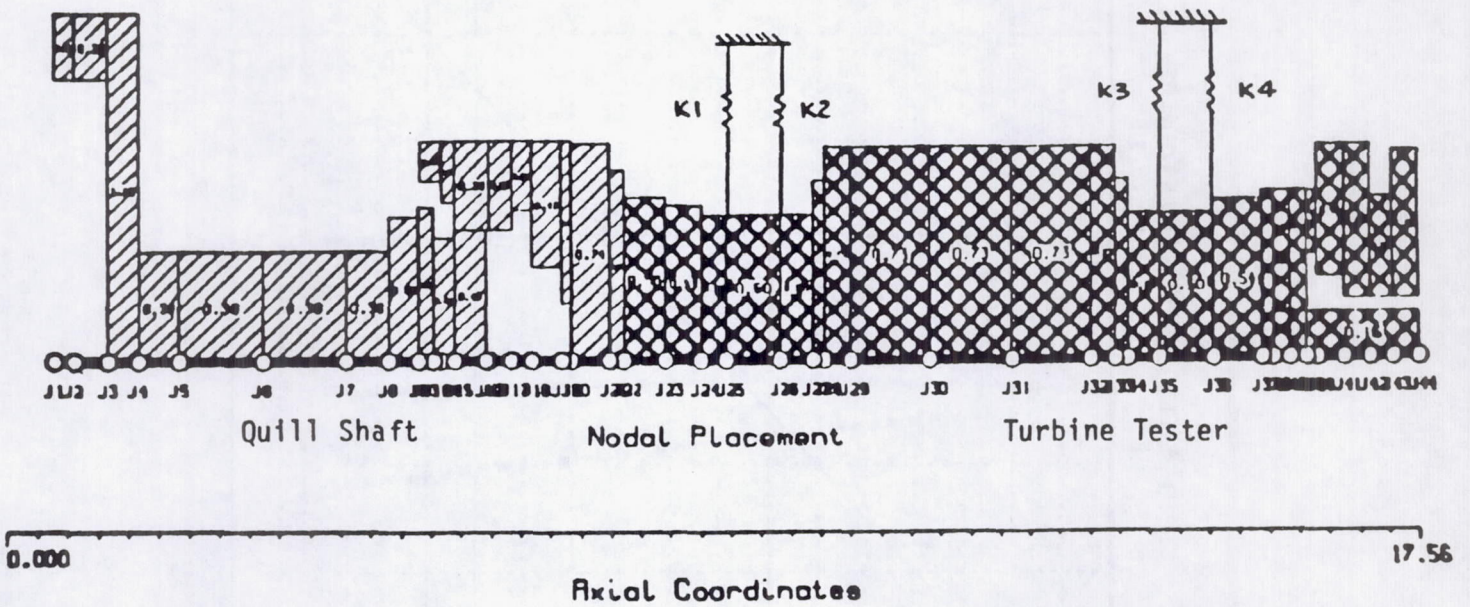

Figure 15

ROTORDYNAMIC CRITICAL SPEED PLOT

MK 49-F TURBINE TESTER - DAMPED CRITICAL SPEEDS
DESIGN - DUPLEX SLAVE BRGS, 1.45 IN SHAFT DIA BETWEEN BEARINGS

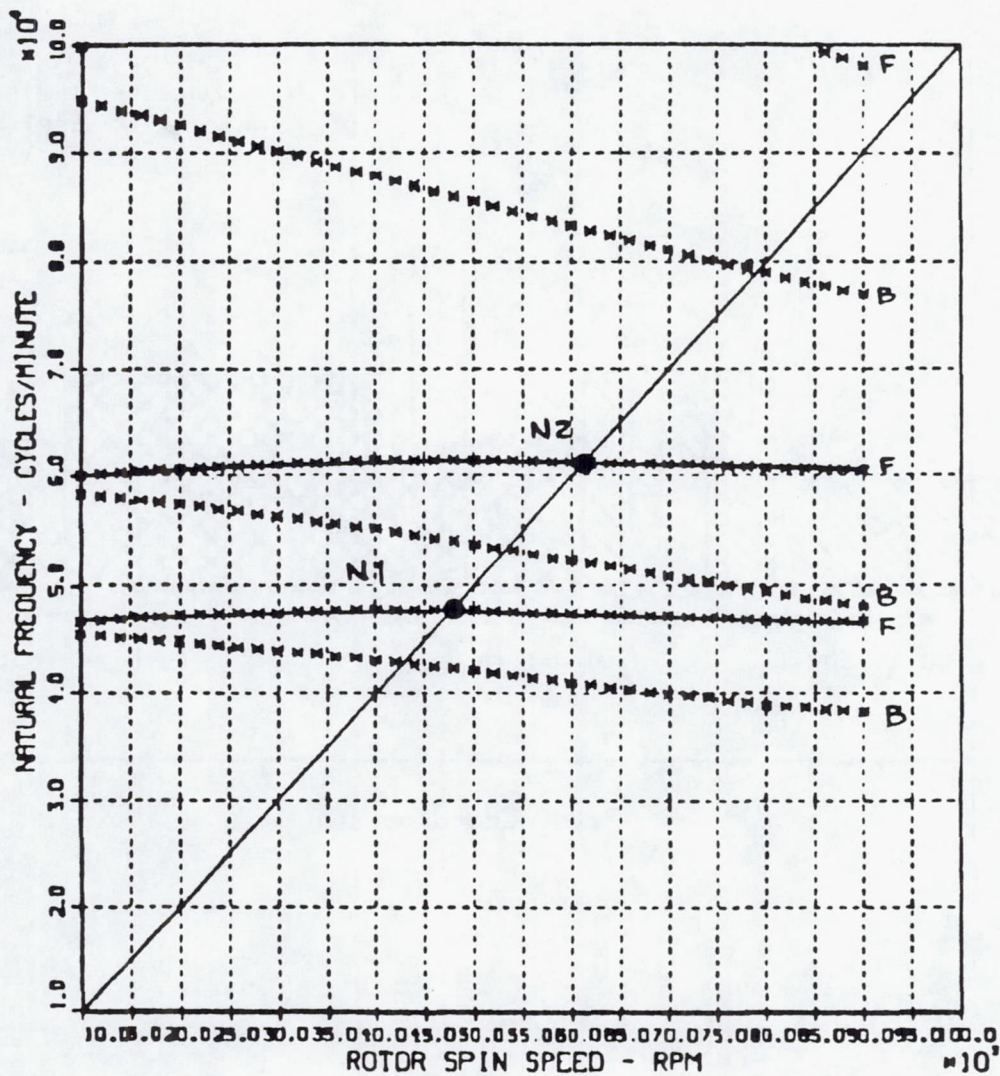

Figure 16

Rotor Group Mode Shape

MK 49-F TURBINE TESTER - DAMPED CRITICAL SPEEDS
DESIGN - DUPLEX SLAVE BRGS, 1.45 IN SHAFT DIA BETWEEN BRGS

1ST ROTOR MODE
47747.RPM

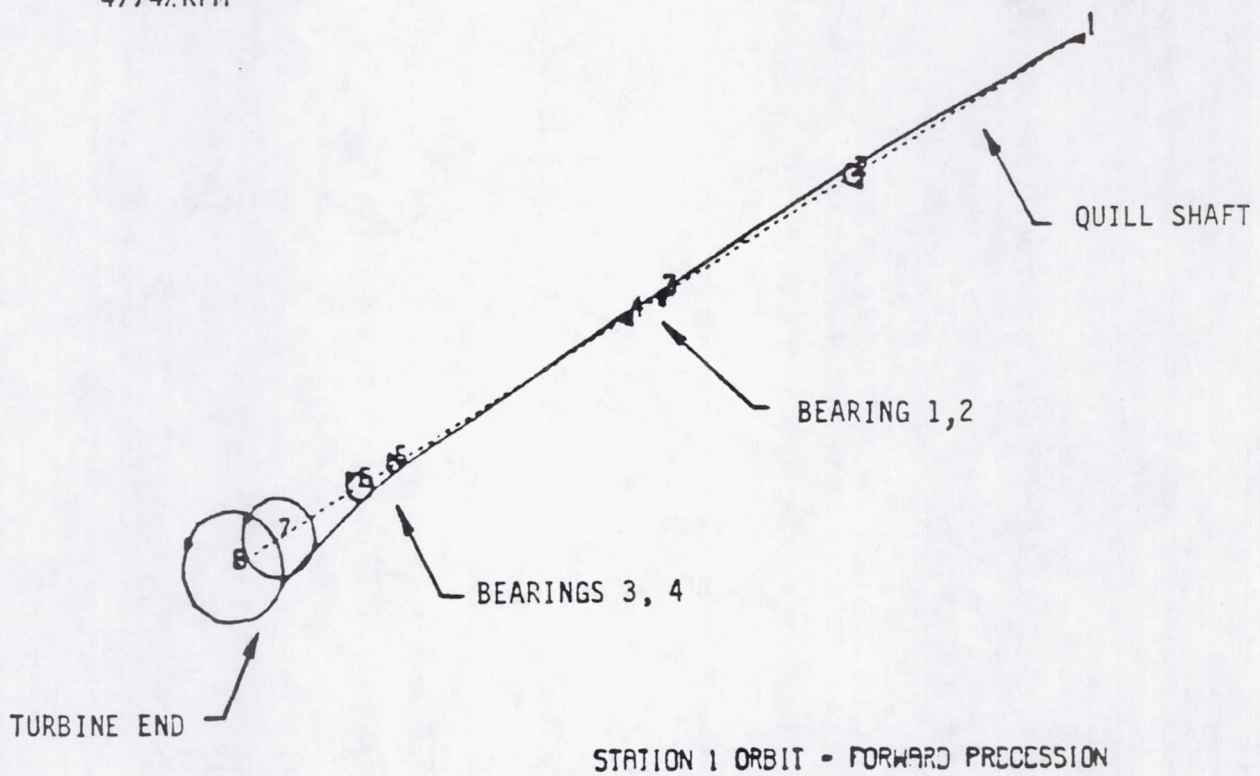
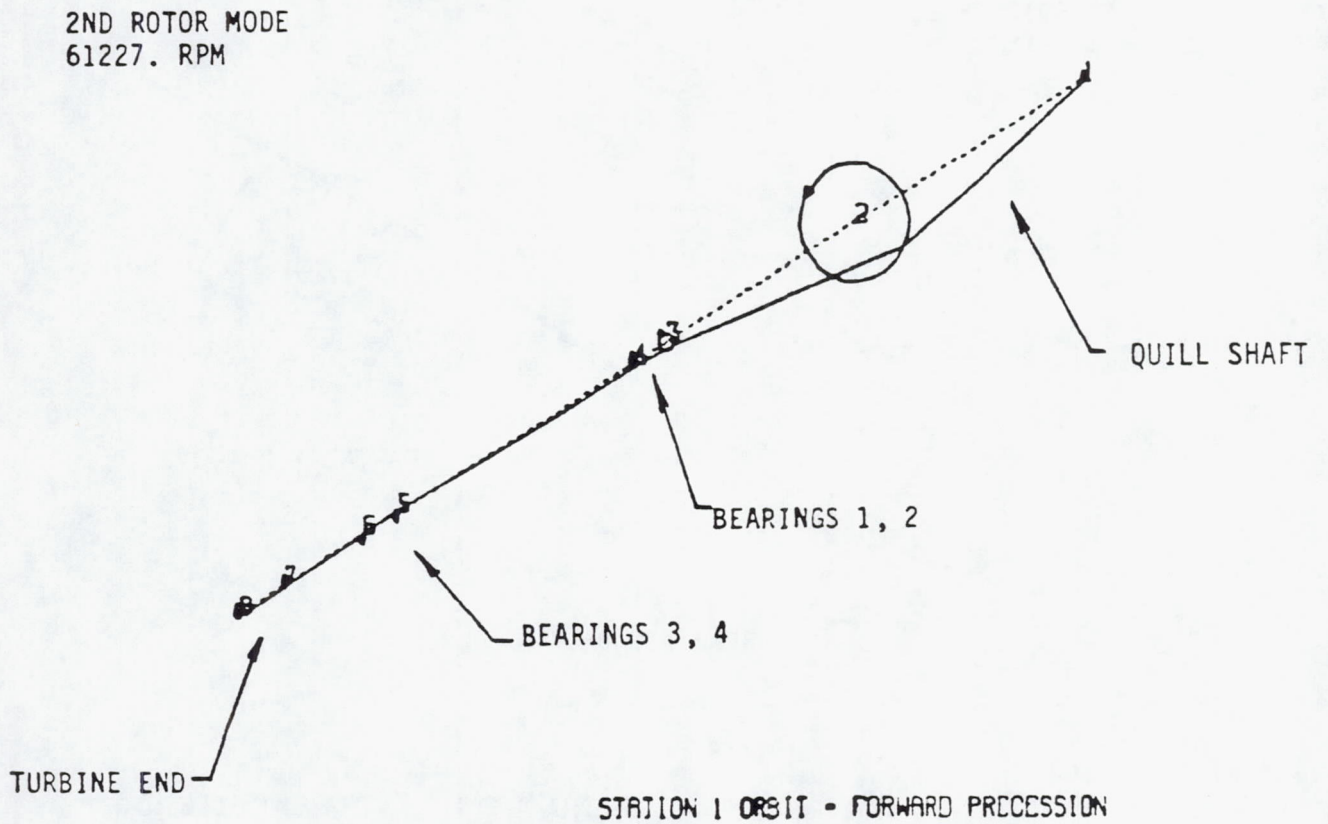

Figure 17

Rotor Group Mode Shape

MX 49-F TURBINE TESTER - DAMPED CRITICAL SPEEDS
DESIGN - DUPLEX SLAVE BRGS, 1.45 IN SHAFT DIA BETWEEN BRGS



A linear response analysis was also performed to assess the bearing loads and rotor displacements as a function of rotor spin speed. For an assumed 1.0 gram-inch residual unbalance, the maximum radial load over the tester's operating range was 250 lbs. at the turbine end bearings. The maximum rotor displacement was .0025 inches peak and occurred at the second stage turbine disk. A more realistic unbalance of 0.20 gram-inches scaled these values to 50 lbs. and .0005 inches peak. Note that these results were for steady-state operation.

The possible addition of squeeze film dampers to the rotor assembly were found to lower the overall response, but also shift the peak response into the operating range of the tester. Thus, the maximum response of the rotor with squeeze film dampers produced higher loads than without the dampers over the tester's operating range, and therefore were not included in the design.

FACILITY DESCRIPTION

Testing was conducted at Rocketdyne's Engineering Development Laboratory (EDL) Rotary 1 Test Facility, which is shown schematically in **Figure 18**. Nitrogen gas for the test turbine was supplied from high pressure storage through a servo controlled valve which regulated turbine upstream pressure during testing. After expanding through the turbine, the gas flowed through the exhaust control valve and was discharged to atmosphere. Power generated by the turbine was absorbed by an electric dynamometer that was coupled to the turbine through a 10:1 speed increasing gearbox, quill shafts, and a brushless torque meter. In order to accelerate the turbine up to test speed without an excessive amount of time or turbine drive gas, the dynamometer was used as the prime mover. **Figure 19** is a photograph of the tester installed in the facility. **Figure 20** shows the start of disassembly in the test cell for nozzle arc of admission changes between tests.

Figure 18
FACILITY SCHEMATIC

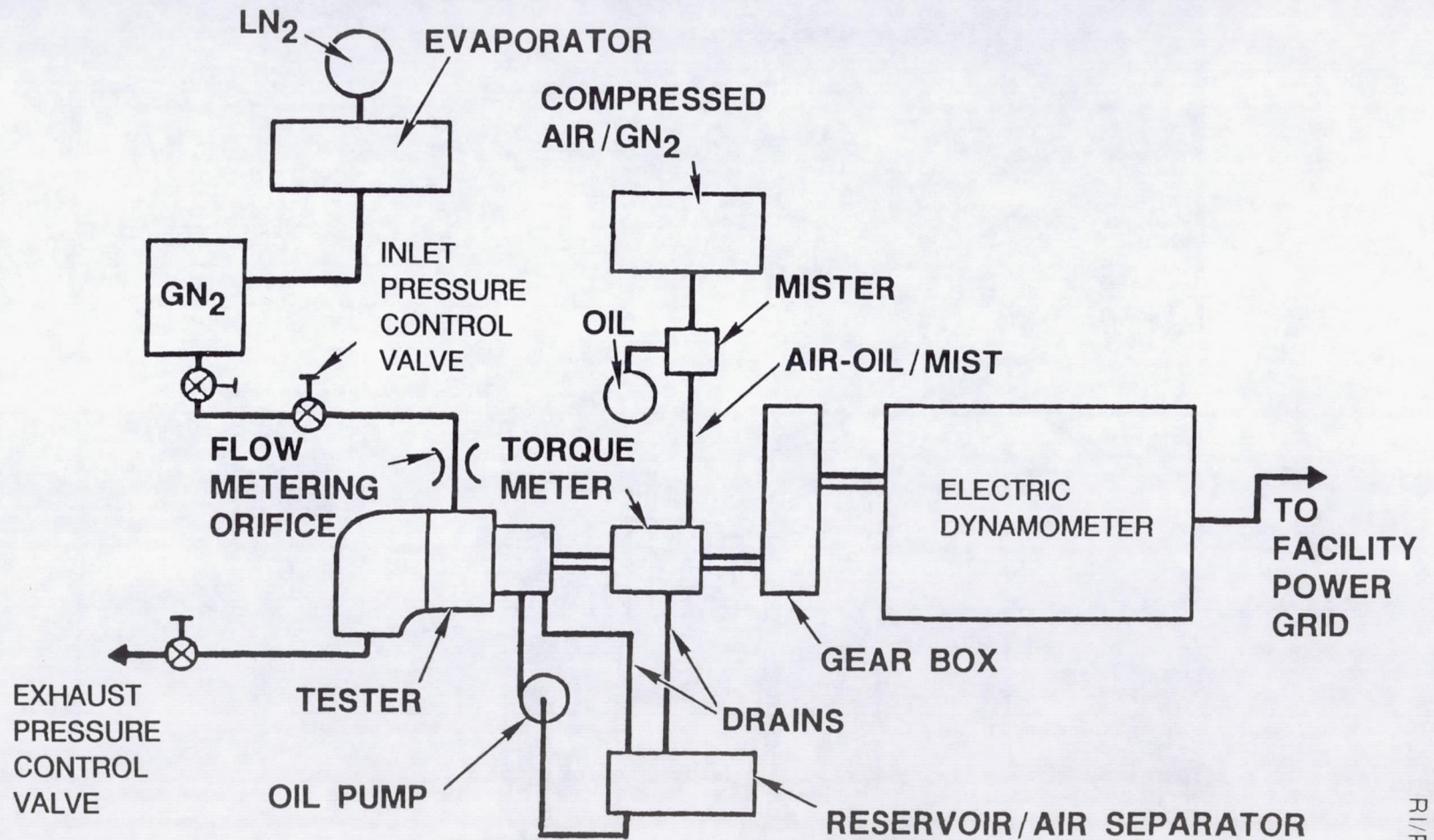

- 31 -

Figure 19 Tester Installation

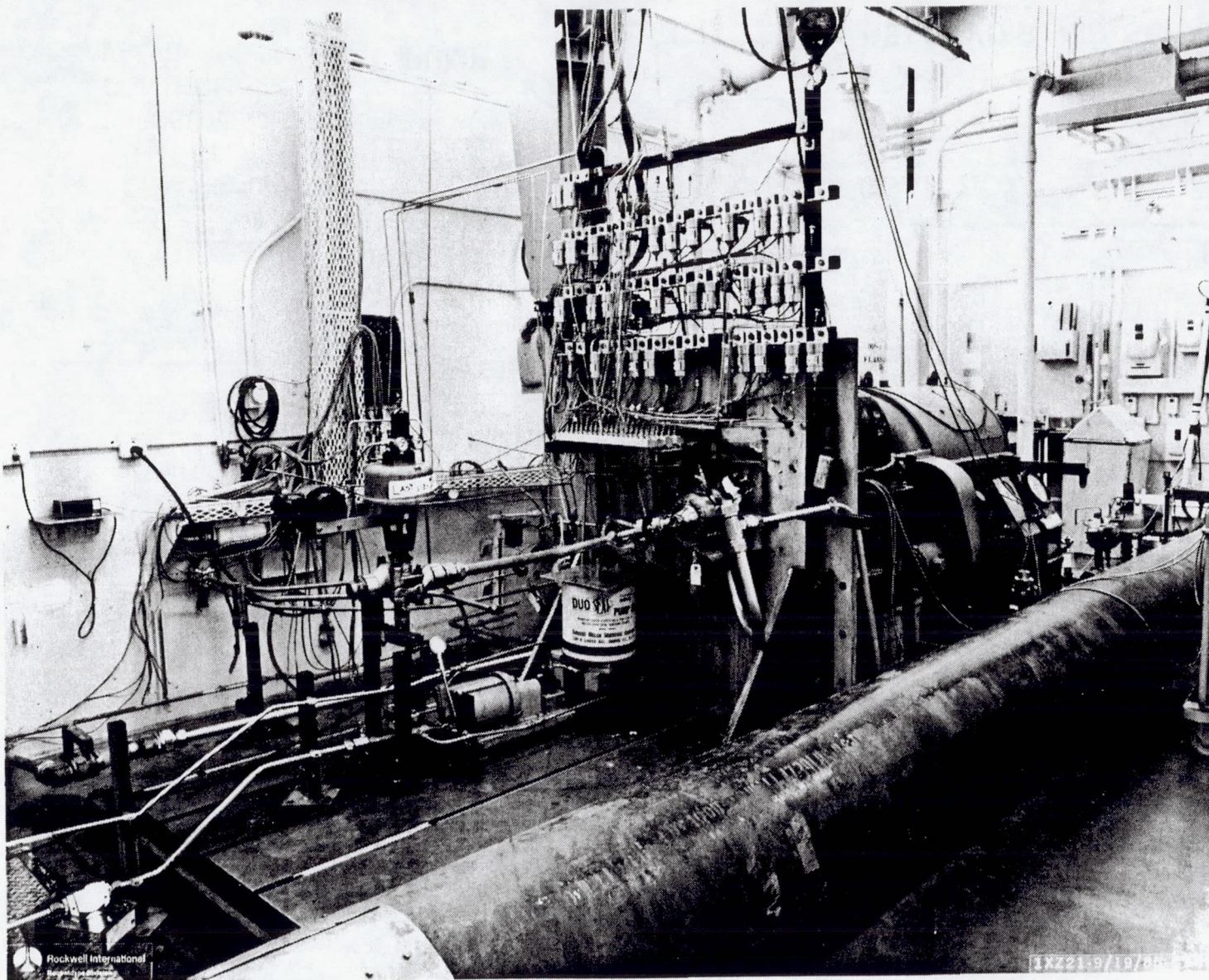

NASA CR-179548
R/IRD 86-214

- 33 - j

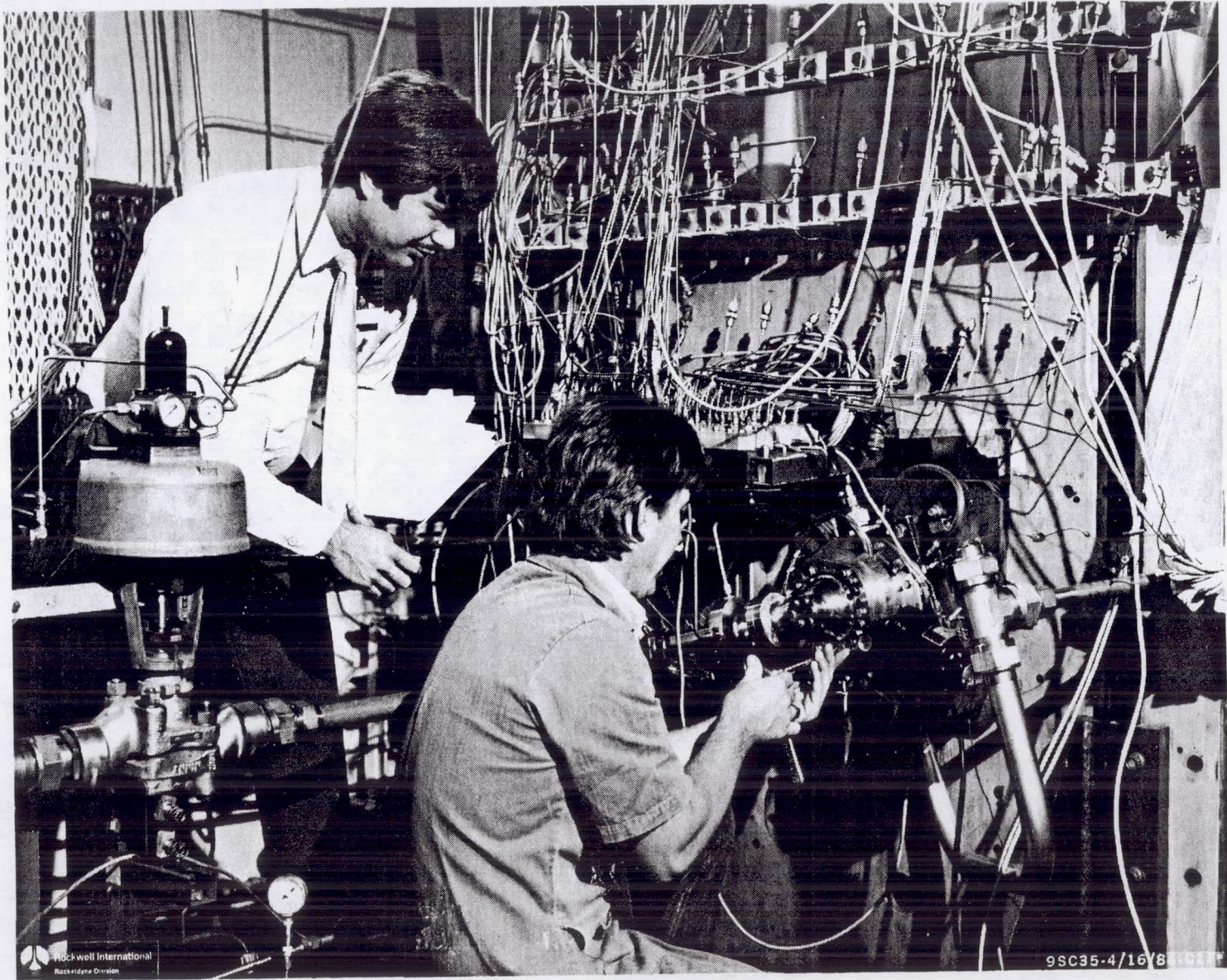

Rockwell International
Racine Engine Division

9SC35-4/16/8

Figure 20 Tester Disassembly

NASA CR-179548
RI/RD 86-214

INSTRUMENTATION

In addition to the instrumentation necessary to determine overall turbine performance, interstage static pressures were measured at selected axial and circumferential locations to determine pressure distributions within the test turbines. Location of the instrumentation is shown in **Figures 21** and **22**. The number designations shown adjacent to the static tap locations refer to the instrumentation channel numbers listed in **Appendix B**.

Shaft speed was measured using an eddy current proximity probe that sensed the rotation of a 0.005 inch, 40 degree arc depression that was machined on the tester shaft. Turbine shaft torque was measured with a torque meter as shown in **Figure 21**. However, torque data was suspect because of problems with the torque meter. Overall turbine performance reported herein was based on first stage nozzle inlet total-to-turbine discharge flange static conditions. Inlet total pressure was measured in the stagnation region of the manifold 180 degrees around the inlet manifold from the inlet pipe as shown in **Figure 22**. Turbine discharge pressure was measured with a four hole static pressure piezometer ring attached at the outlet flange parting line. Inlet and discharge temperatures were measured at the respective pressure measurement locations. Nitrogen gas flow rates were measured upstream of the inlet flange with a sonic flow nozzle. Because of the wide flow range, different size flow nozzles were necessary for each of the three test configurations. Efficiency characteristics of the test turbines were calculated from the measured temperature drops across the turbine.

Static pressure taps within the turbine, which included first and second stage nozzle flow channel hub and tip taps at the inlet and discharge locations, are shown in **Figure 22**. The channel taps were positioned at the midpoint of the channel in the plane of the respective nozzle blade leading or trailing edge. Taps were also located on the upstream and downstream surfaces of the nozzle block at a three inch diameter, approximately 90 degrees from the centerline of the arcs of admission as shown. The second stage nozzle inlet and outlet cavity pressure taps shown in **Figure 22** were located on a two inch diameter.

Additional data parameters necessary for safely conducting the tests were monitored in real time in the facility control room. These included the redline parameters, facility status, and test condition monitors.

Figure 21

INSTRUMENTATION PARAMETER LOCATIONS

TWO-STAGE PARTIAL ADMISSION TURBINE TESTER

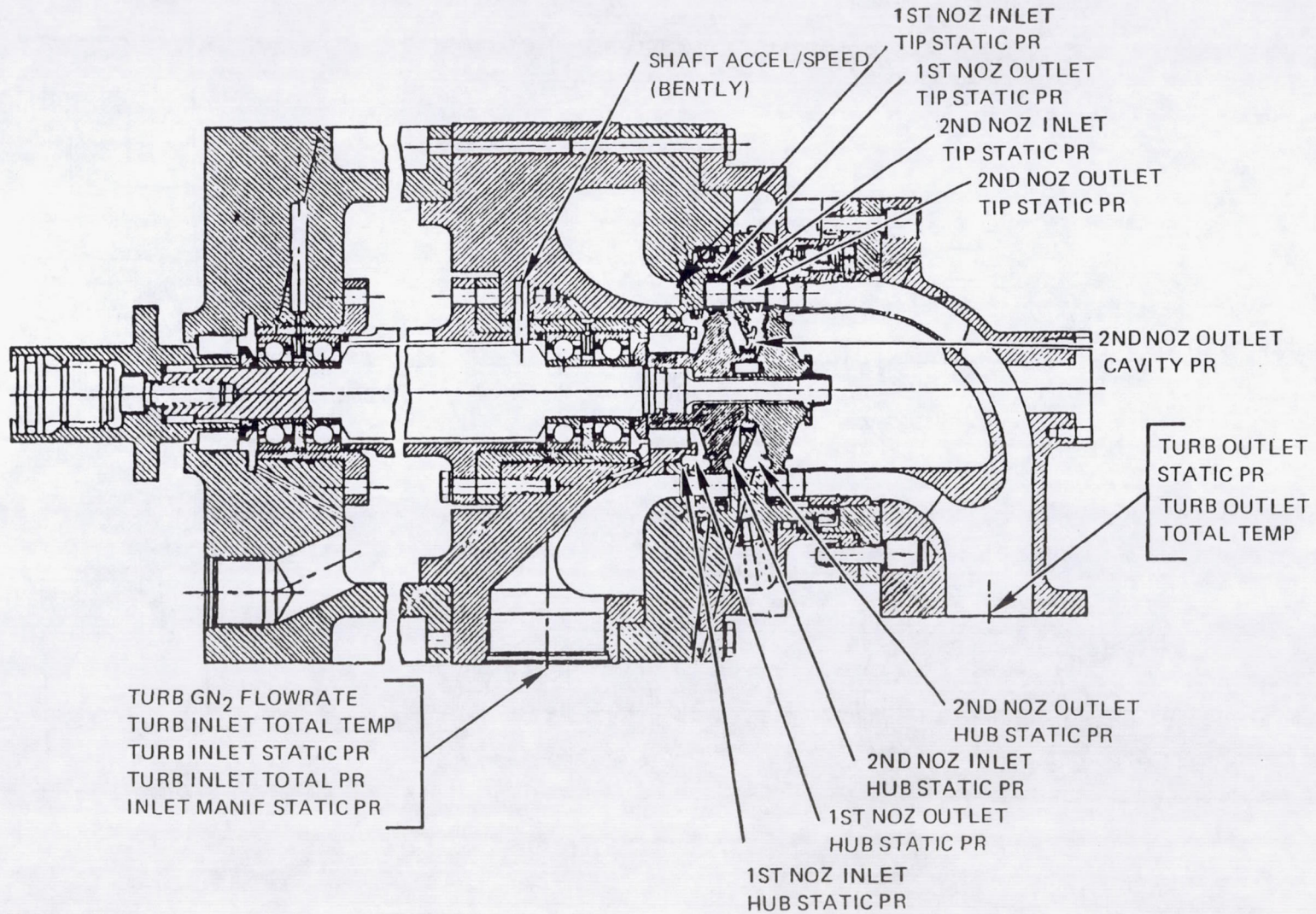

- 35 -

FIGURE 22 Static Pressure Tap Locations

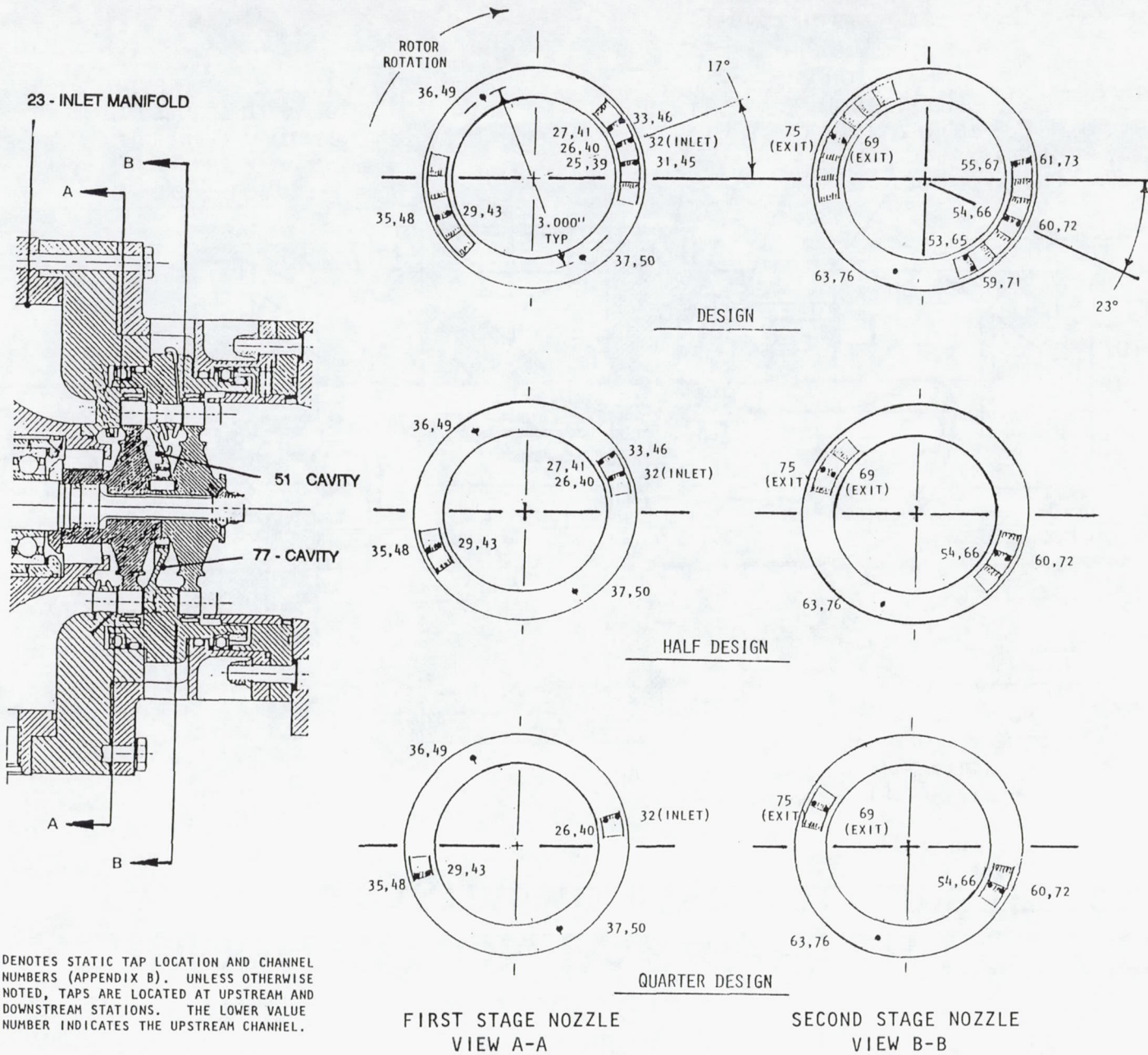

DATA ACQUISITION AND ANALYSIS

A flow chart showing the steps involved in the acquisition and analysis of the test data is presented in **Figure 23**. Only steady-state operation data were recorded. The individual data parameters were recorded on a measurement group System 4000. The System 4000 recorded the transducer output voltage data on floppy disks which were later used as the database for a scaling program. The scaling program converted the voltage data onto another set of floppy disks in engineering units (pressure, temperature, torque, etc.). Since the System 4000 utilized a Hewlett Packard computer which was not IBM compatible, the scaled data was transmitted to the IBM directly via an RS-232 port line.

The Lotus 1-2-3 spreadsheet program was used to reduce the scaled data to performance parameters. It was also used to produce a majority of the performance plots. An engineering generated macro program was written that automatically read the scaled data, averaged it, and then stored this averaged test data in the format required for the performance reduction program. The test data required averaging because each test slice consisted of 10 to 20 scans at one steady state test condition.

The performance program was also an engineering generated macro program that automatically read the averaged data and performed iterative calculations for performance parameters. These performance parameters were used to produce performance plots.

Real gas properties were used in the analysis of the test data. The curve fit equations of the property data along with the equations used in the data analysis are given in **Appendix C**.

The flowrates were obtained by applying the ideal isentropic critical flow equation across the nozzle. The specific heat ratio used in the analysis was obtained by a curve fit equation that characterized the real property gamma as a function of temperature and pressure. The total pressure and temperature were obtained by iterating the Mach number at the nozzle inlet. The mass flowrate was calculated, from the ideal isentropic critical flow equation, with the Mach number equal to 1.0 at the nozzle throat. The total pressure was initially assumed equal to the measured static pressure. Applying this initial assumption, a Mach number at the nozzle inlet was calculated. A new total

Figure 23 TWO STAGE PARTIAL ADMISSION TURBINE TEST DATA ACQUISITION - ANALYSIS -

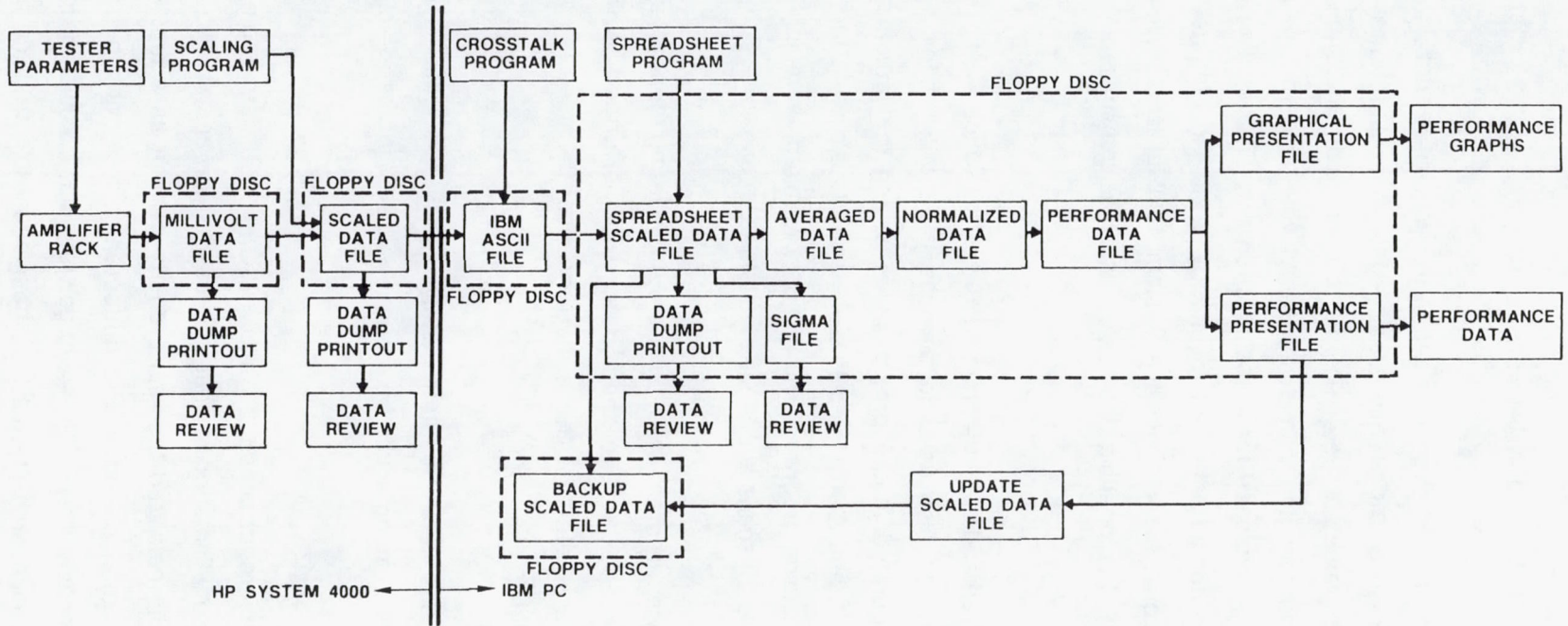

- 38 -

pressure was then calculated. This process was repeated about 3 times before any further change occurred.

The turbine efficiency was obtained by dividing the actual enthalpy drop across the turbine by the isentropic enthalpy drop.

$$\text{Efficiency} = \frac{h_{in(\text{act})} - h_{out(\text{act})}}{h_{in(\text{act})} - h_{out(\text{isen})}}$$

Two curve fit equations of real gas properties were used to calculate enthalpy; one as a function of temperature (T) and pressure (P), and the other as a function of pressure (P) and entropy (S). A curve fit equation was also used for the entropy calculation, as a function of pressure and temperature. The pressure and temperature measured at the inlet were used to obtain the turbine inlet enthalpy. The pressure and temperature measured at the outlet were used to obtain the actual outlet enthalpy. The turbine outlet pressure and calculated inlet entropy were used to obtain the turbine outlet isentropic enthalpy.

TEST MATRIX AND PROCEDURES

Testing was conducted with nitrogen gas at turbine inlet manifold total pressure and temperature of approximately 215 psia and 480 degrees Rankine, respectively. Target test speeds were 50, 70, 100, and 120 percent of the design equivalent speed. At each test speed, data was recorded at target pressure ratios of 1.3, 1.6, 1.74 (design) and 2.0 with the second stage-to-first stage nozzle angular orientation set at the design angle (+40 degrees as shown in **Figure 22**) and at -30, -10, +10, and +40 degrees (+30 degrees for the "quarter design" configuration) from the design angle. Positive second nozzle angle rotation was opposite the rotor rotation direction.

The turbines operated by setting inlet conditions and motoring the turbine to the test speed with the electric dynamometer. Test pressure ratio was set by adjustment of the exhaust control valve with the turbine output power absorbed by the dynamometer. At each test pressure ratio, the second stage nozzle was remotely rotated to each of the angle settings noted above.

Static pressure checks were performed before and/or after the main portion of each test. The system was pressurized to approximately turbine inlet pressure (200 psig) with the discharge valve closed and the shaft at or near zero speed. The pressure transducers were checked to verify that all read nearly the same value. Significantly lower pressure values indicated leaks in the instrumentation lines that would have caused erroneous readings during the test.

Three test series involving a total of thirteen tests were conducted accumulating approximately 36 hours of run time on the rotor assembly. The first series (seven tests) included checkout and what was intended to be performance testing of the design arc of admission configuration. However, a problem with nozzle plug retention caused by inadvertent reverse motoring of the turbine, along with instrumentation problems, precluded the use of the first series test data. In the second series (tests 8, 9, and 10), each of the turbine configurations was tested at the target speeds, pressure ratios, and nozzle angle settings noted above. After completion of test 10, the thermocouples used to measure gas temperatures at the sonic flow nozzle and at the turbine inlet manifold were found to be malfunctioning. Subsequent flow checks failed to provide temperature data that could be used with confidence, and therefore a third test series (tests 11, 12, and 13) was conducted to determine turbine performance. Since the pressure data from the second series was valid and relatable to the performance tests because of similar inlet conditions, the level of instrumentation in the third test series was reduced to only what was necessary to determine turbine overall isentropic efficiency.

The second and third test series were run without the exhaust flow guide installed. The flow guide performance effects were to have been evaluated in the first test series, but the plug retention and instrumentation problems noted above made evaluation impossible.

TEST RESULTS

Efficiency test data for the design admission configuration, the half design admission configuration, and the quarter design admission configuration are shown for the 0 degree second nozzle orientation angle in **Figure 24**. Smaller admission resulted in lower peak efficiency, and peak efficiency occurred at lower velocity ratios. The peak efficiency and velocity ratio values are listed in **Table 5**.

**Table 5. Test Peak Efficiency for Arc of Admission
 (0 Degree, Second Stage Nozzle Orientation)**

Configuration	% Admission		Peak Efficiency (%)	Velocity Ratio (U/CO) @Peak Efficiency
	1st stage	2nd stage		
Design	34.5 (10 of 29)	45.2 (14 of 31)	68	0.30
Half Design	13.8 (4 of 29)	19.4 (6 of 31)	47	0.24
Quarter Design	6.9 (2 of 29)	12.9 (4 of 31)	36	0.18

The equivalent flow test data for the three nozzle arcs is shown in **Figure 25**. Similar trends of increasing flow with increased pressure ratio are shown for each admission. The spread with equivalent speed was small for design admission and became smaller as admission was reduced.

The test data analyses included determination of the turbine efficiency characteristics, flow characteristics, internal pressure distributions, and turbine axial thrusts. All admission configurations and second stage nozzle orientation tests were conducted without the exhaust duct flow guide installed. Comparisons were made of the test results and the design predictions. The results are presented in terms of standard air inlet condition equivalent parameters: equivalent flow (W_{eq}), equivalent speed (N_{eq}), equivalent pressure ratio (P_{Req}), and efficiency (η). These parameters are described

in **Appendix A**. The equivalent pressure ratios were determined from the first stage nozzle inlet total pressures and the elbow duct outlet flange static absolute pressures.

The performance test results included the efficiencies and flow characteristics. These characteristics for the three arcs of admission found in **Table 5** were determined from test 11 for the design admission, from test 12 for the half design admission, and from test 13 for the quarter design admission. The test data and performance parameters for these tests are listed in **Appendix D**. The efficiency characteristics were calculated from the measured temperature drop across the turbine because of problems with the torque meter data.

Figure 24

EFFICIENCY VS. U/CO , 0 DEGREE ORIENTATION

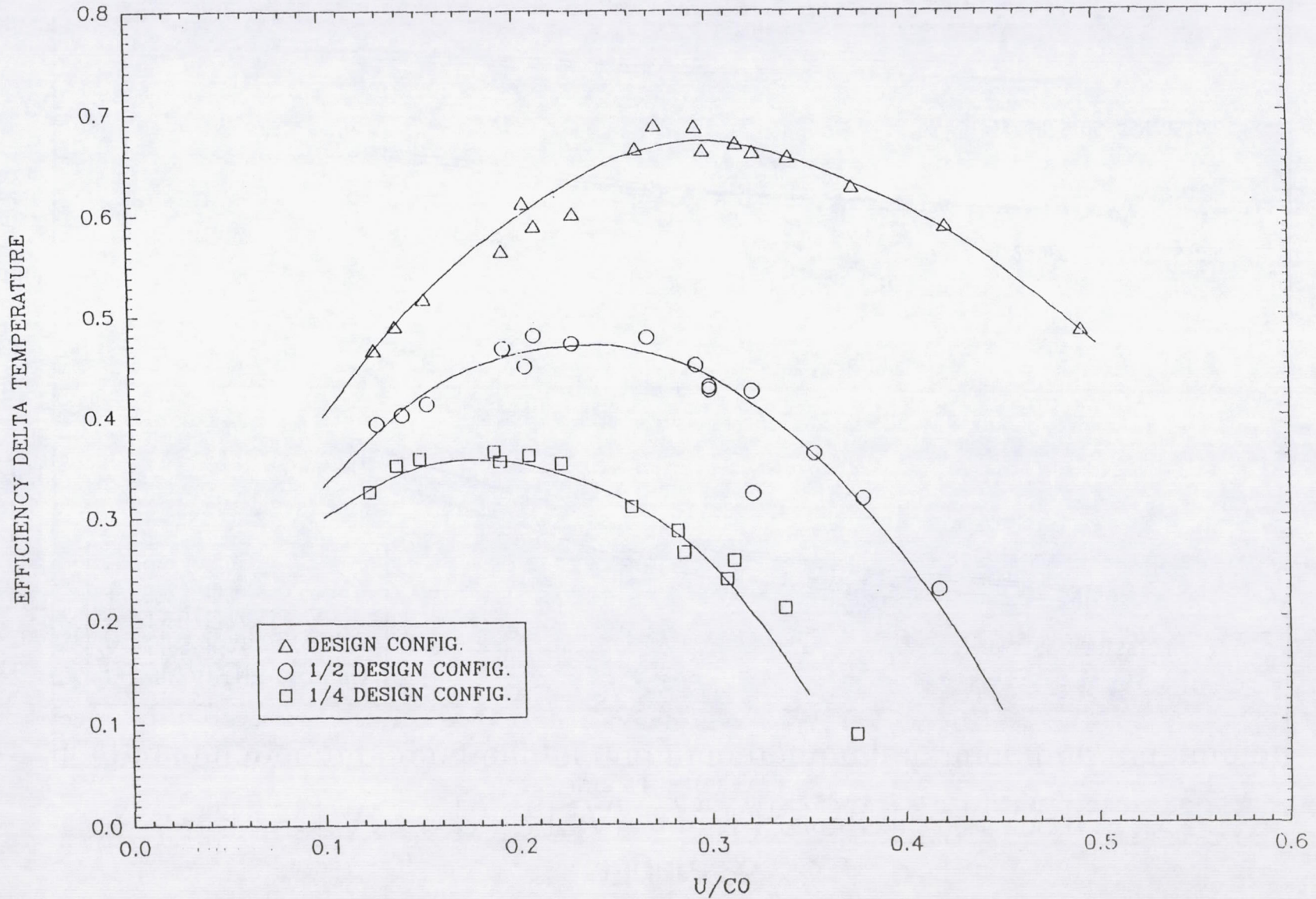
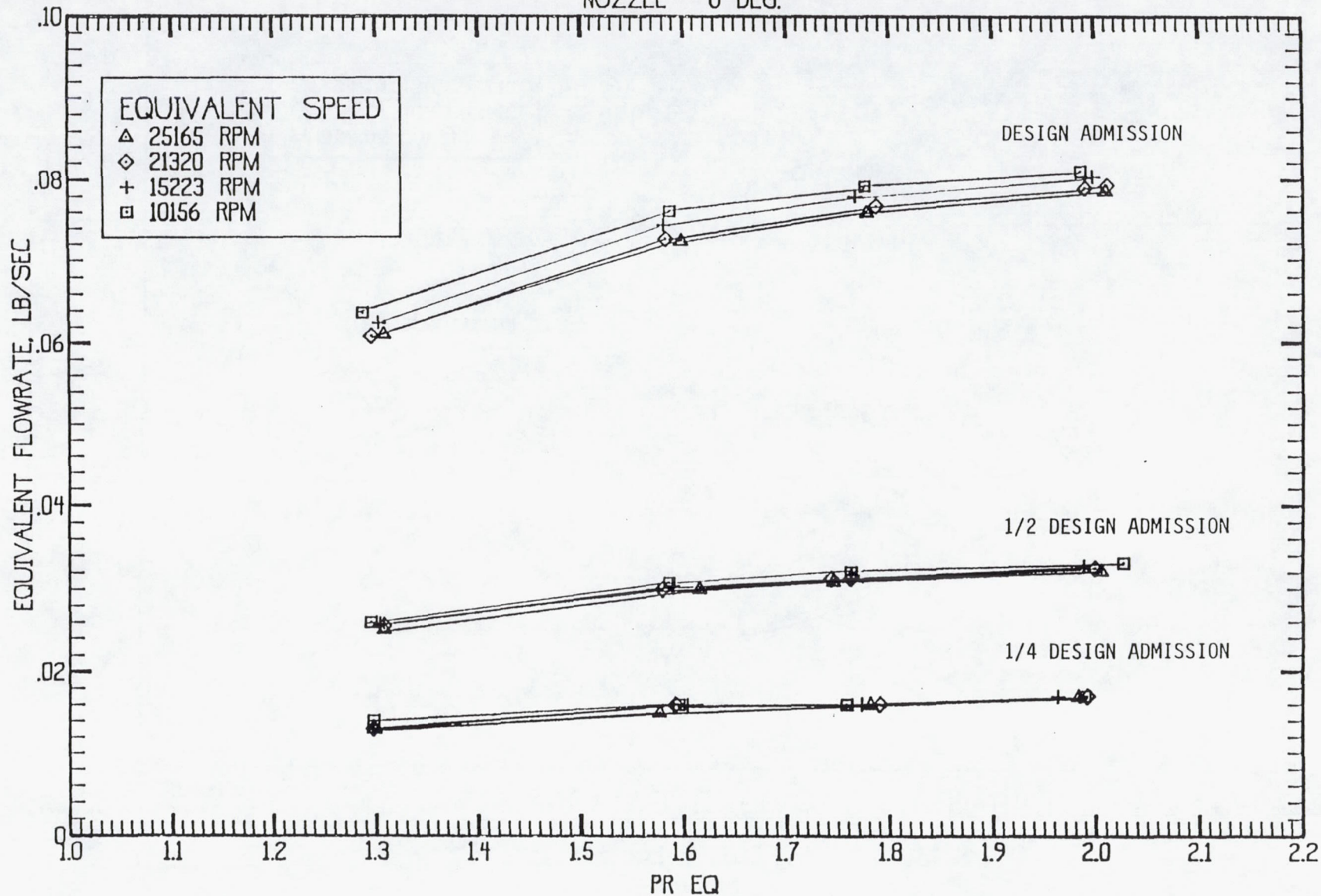

Figure 25

2 STAGE PARTIAL ADMISSION TURBINE

NOZZLE - 0 DEG.



The turbine pressure distribution data and the turbine axial thrust calculated from the pressure distribution data were obtained from test 8 for the design admission configuration, from test 9 for the half design admission configuration, and from test 10 for the quarter design admission configuration. These tests were found to have erroneous temperature measurements and, therefore, were not usable for the performance determinations. Test data for tests 8, 9, and 10 are listed in **Appendix B**.

The interstage static pressure distributions for the three configurations are shown in **Figure 26** for the design equivalent conditions. Higher overall pressure ratios were used for the half and quarter configurations because of the higher second-to-first stage nozzle area ratios. The inactive arc pressures (triangle symbols) were equal across the first rotor as expected with the inactive rotor blade flow passage areas equalizing the pressures. Positive pressure drops are shown in the active arcs for the both tip and hub pressures across the first rotor and across the tip of the second rotor. Slight positive rotor blade reaction is shown for good performance in the active flow region. The higher pressure differences between tip and hub at the exit of the first stage nozzle and second stage nozzle reflect the high nozzle outlet swirl compared to the nearly axial rotor outlet swirl and nearly equal hub and tip pressures. Higher first stage pressure ratios are shown for the half and quarter configurations reflecting the higher second-to-first nozzle area ratios. These configurations require higher overall pressure ratios than were tested in order to produce more equal stage pressure ratios and power splits.

Turbine rotor axial thrust values were calculated using measured static pressure averages from each interstage location (**Figure 26**) for the three configurations at the design equivalent conditions. The turbine axial thrust values are shown in **Table 6**, which includes the turbine axial thrust ratios (turbine thrust divided by turbine inlet pressure). The turbine axial thrust for each engine condition was determined by scaling the test pressure ratios by the engine turbine inlet pressures and calculating the thrust. Turbine thrust was defined as positive in the direction of turbine through-flow.

Figure 26

INTERSTAGE STATIC PRESSURE DISTRIBUTIONS
(AVERAGES OF MEASUREMENTS AT LOCATIONS)

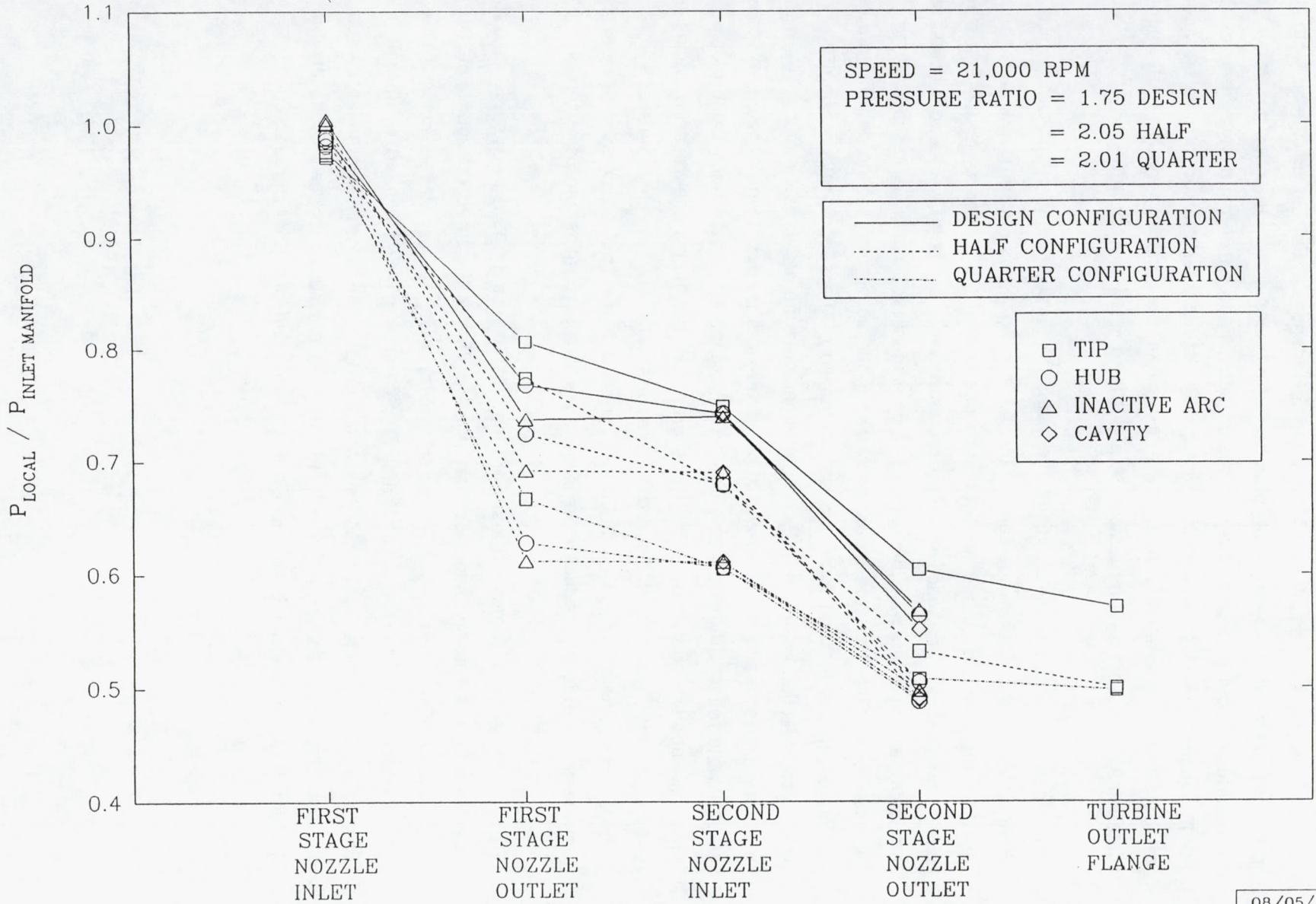

- 46 -

Table 6. Turbine Axial Thrust From Pressure Forces
 (POSITIVE AXIAL THRUST IN DIRECTION OF TURBINE THROUGH-FLOW)

PARAMETER	CONFIGURATION		
	DESIGN	HALF	QUARTER
TEST AXIAL THRUST, LB _f	-120	-109	-122
AXIAL THRUST/INLET PRES., LB _f /PSIA	-0.56	-0.51	-0.57
ENGINE AXIAL THRUST, LB _f	-2109	-1912	-2118

In the sections that follow for each configuration, detail figures are included that show the locations, pressures, areas, and forces for the two-stage partial admission turbine axial thrusts that are summarized in **Table 6**. The application of the pressure forces and the general trends are discussed below.

First stage rotor disk and blade axial thrust was calculated from pressure forces acting on the area from the shaft seal and interstage seal diameters to the rotor tip diameter. Second stage rotor axial thrust pressure forces acted on the areas from the interstage seal diameter to the rotor tip diameter on the upstream side and from the tip diameter to the shaft centerline on the downstream side. The blade annulus area was defined from the blade hub diameter to the rotor tip seal diameter. The diameters were taken from the rotor drawings. The average of the inactive arc pressures was applied over the inactive arc rotor blade faces and over the disk faces when the chamber pressure was not measured. The average active arc pressures were applied over the active arc rotor blade faces.

The disk and blade pressure forces were nearly balanced for the rotors with partial admission. Most of the turbine axial thrust resulted from the unbalanced pressure on the downstream side of the second rotor over the area from the interstage seal diameter to the shaft centerline. This pressure force was directed upstream, opposite the turbine through-flow, and is listed with a negative sign in **Table 6**. These test results show that partial admission stages provided the lowest axial thrust across blade and disk surfaces of any staging option.

DESIGN ADMISSION CONFIGURATION

The design admission configuration consisted of a first stage with 34.5 percent admission and 10 of 29 full ring nozzles flowing, 5 per half 180 degrees apart, and a second stage nozzle with 45.2 percent admission and 14 of 31 nozzles flowing, 7 per half. The second stage to first stage nozzle admission ratio was 1.310.

Design Configuration Efficiency Characteristic

The efficiency characteristic for each of the 5 second stage nozzle orientation angles is shown in **Figure 27** versus velocity ratio. Highest efficiency is shown over most of the range for the +10 degree orientation, and the lowest efficiency for the -30 degree orientation.

The design second stage nozzle orientations with test rotations for the maximum angles are shown schematically in **Figure 28**. The +10 degree nozzle orientation, which related to a 30 degree angle between the center of the first nozzle inlet arc of admission and the center of the second stage nozzle inlet arc of admission in the direction of rotation, provided the highest efficiency (not the design 40 degrees as expected). This indicated that the flow velocity through the first stage was higher than predicted.

The efficiencies and equivalent flowrates for the targeted design equivalent speed of 21,219 RPM and pressure ratio of 1.765 for the 5 second stage nozzle orientation angles are listed in **Table 7** with the design equivalent prediction. The test efficiencies at design conditions were plotted in **Figure 29** versus second nozzle orientation, along with the design prediction. The design orientation test efficiency was 68.6 percent compared with 63.6 percent for the design prediction. The test value was 6.7 percent, 4.3 percentage points higher than predicted, for the test measurement locations of first stage nozzle inlet total and outlet flange static pressure. The test efficiency adjusted to the design locations of inlet flange total and outlet flange total pressure was 67.9 percent. The efficiencies for the +10 degree and +40 degree second nozzle orientations were 68.8 and 68.6 percent, respectively. High test efficiency was shown over a wide range of second nozzle orientation angles.

Figure 27

2 STAGE PARTIAL ADMISSION TURBINE

EFFICIENCY VS U/CO

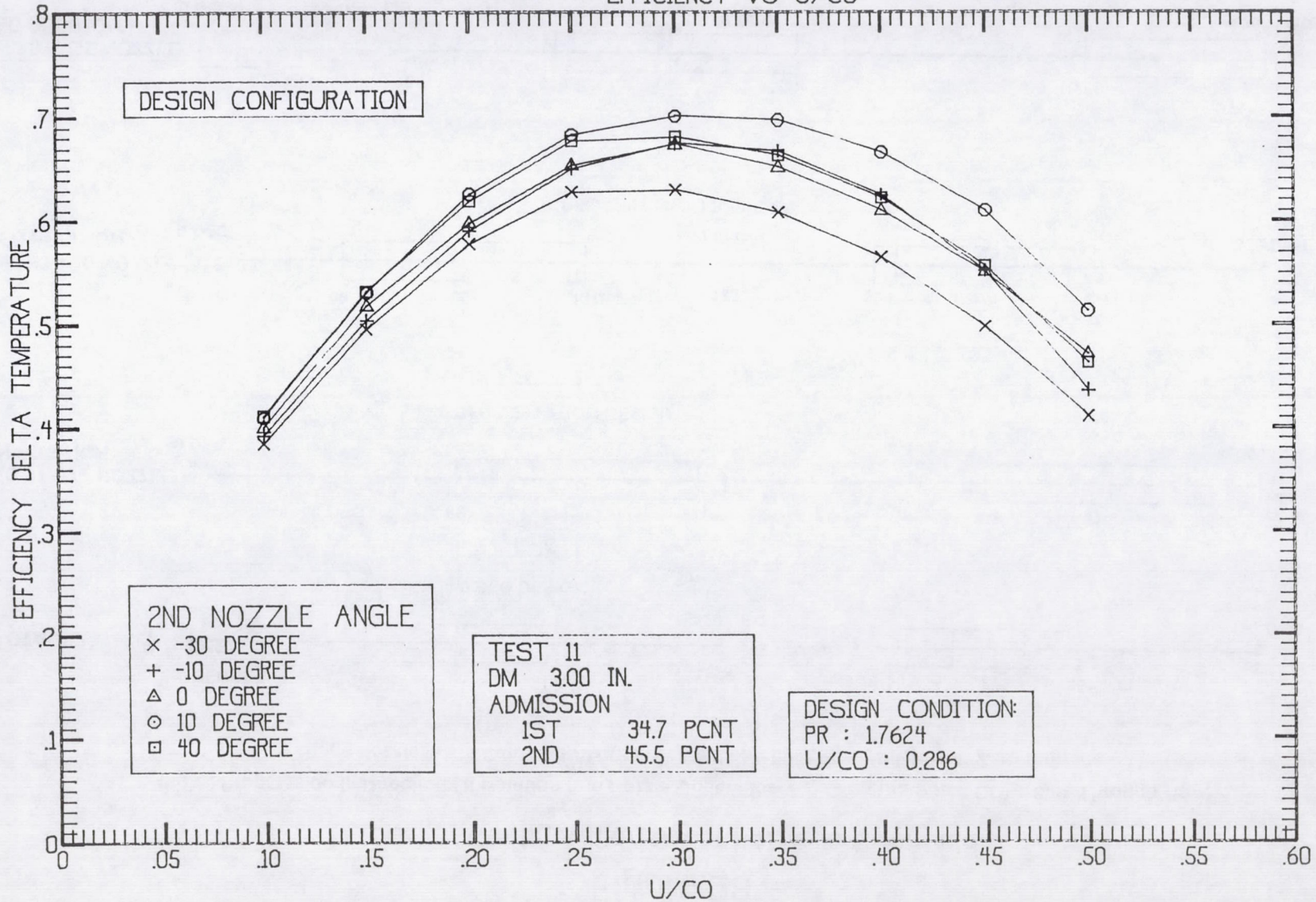

Figure 28

Design Configuration Second Nozzle Orientation

Angle Progression In Direction Of Rotation And Nozzle Outlet Flow (Looking Upstream Of Turbine Through-flow)
 First Stage Nozzle Inlets Centered About Inlet Manifold Inlet Pipe Which Is At Zero Degrees

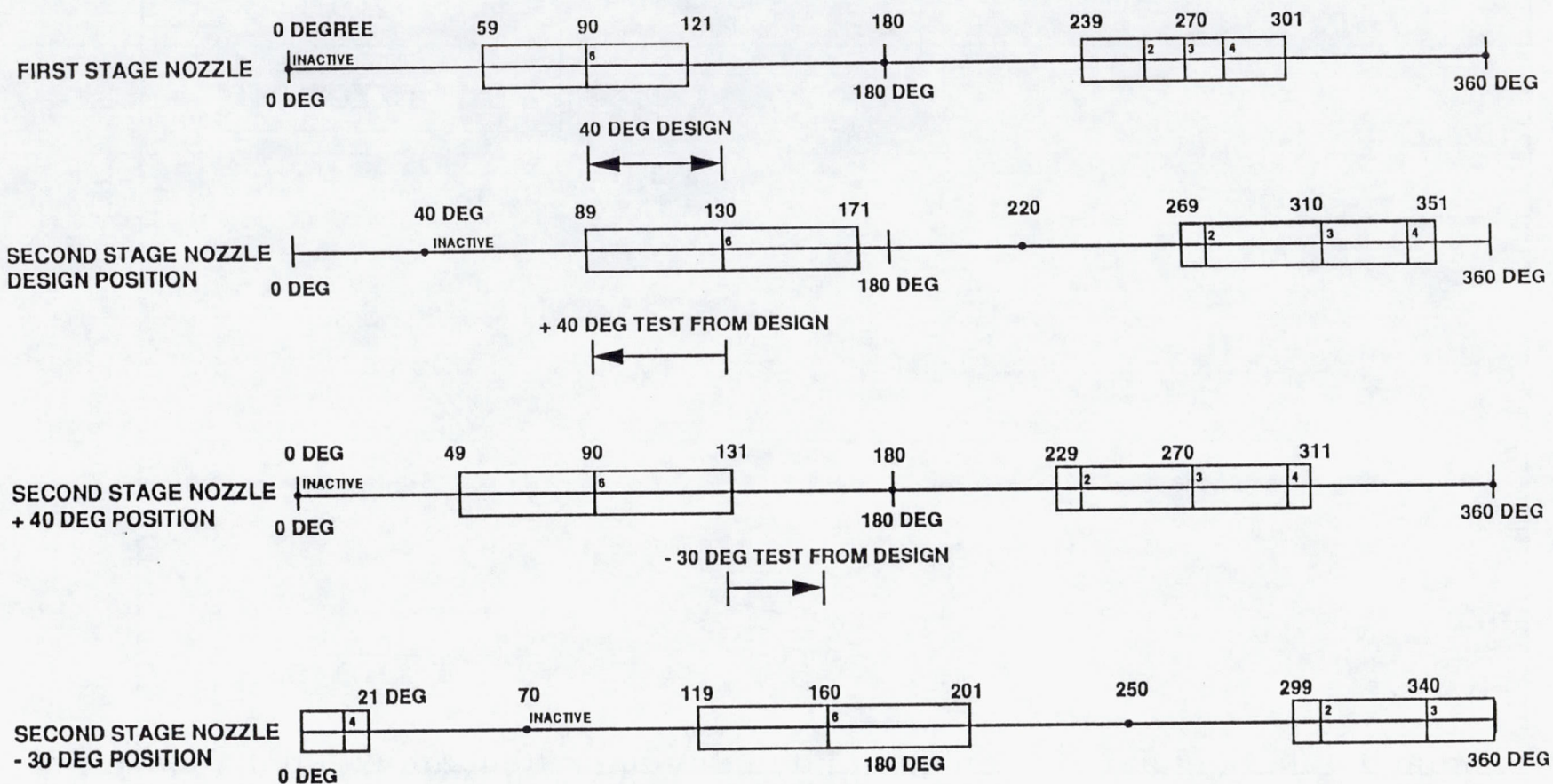

Table 7

TARGET N (eq) AND PR (eq)
 DESIGN ARC OF ADMISSION

2-N ANGLE, DEGREES	LINE NUMBER TEST 11	N (eq) RPM	PR (eq)	FLOW (eq) LB/SEC	EFFICY (ETA)	Um/Co
0	PREDICTED	21219	1.7651	0.0744	0.636	0.286
-30	45	21246	1.780	0.0751	0.638	0.289
-10	51	21599	1.767	0.0760	0.677	0.295
0	57	21690	1.787	0.0767	0.686	0.294
+10	63	21526	1.766	0.0769	0.688	0.294
+40	71	21320	1.761	0.0766	0.686	0.292

Figure 29

2 STAGE PARTIAL ADMISSION TURBINE
TEST 11, DESIGN CONFIGURATION

NASA CR-179548
R/RD 86-214

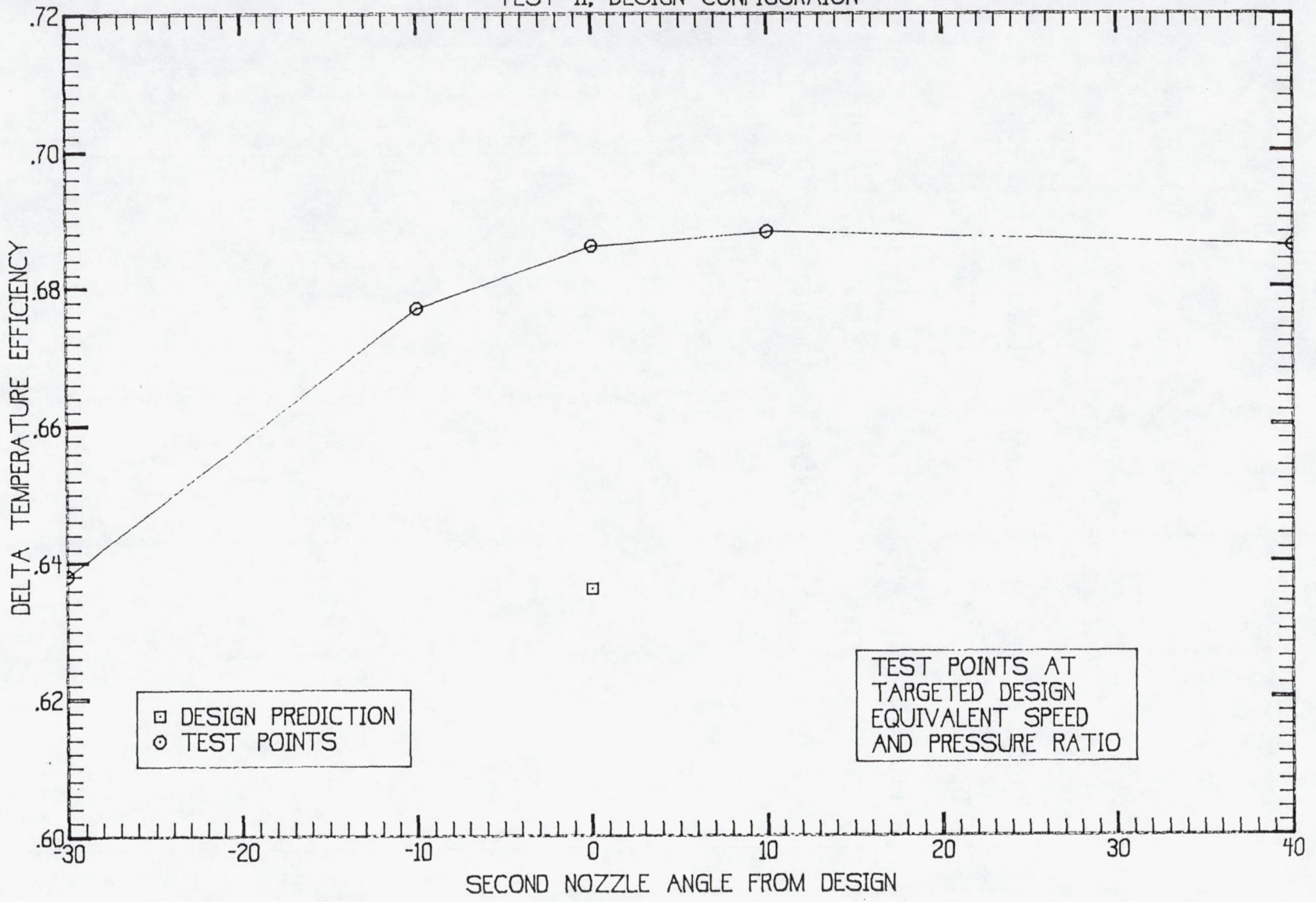

The slight efficiency decrease for the +40 degree orientation indicated that +40 degrees was beyond the optimum, which was apparently between the +10 and +40 angles for the design admission configuration. Nozzle orientation was shown to significantly affect efficiency. An increase of 5.0 percentage points or 7.8 percent was shown in efficiency from -30 to +10 degree orientations.

Design Configuration Flow Characteristic

The equivalent flowrate versus pressure ratio for the targeted design equivalent speed test points are shown in **Figure 30** for each of the five second stage nozzle angles, along with the predicted values. The equivalent flow for the test points targeted at the design equivalent speed and pressure ratio from **Table 7** are shown in **Figure 31** versus second stage nozzle orientation, along with the design prediction. The equivalent flow at the 0 degree design orientation was 3.1 percent higher than predicted. At +10 degrees, the equivalent flow was 3.4 percent higher than the design prediction. As with the efficiency characteristics, all the test equivalent flow values were higher than the design predictions. The equivalent flow decrease from the +10 to +40 degree orientation indicated that +40 degrees was beyond the optimum which was between +10 and +40 degrees, as with the efficiency characteristic. The increased flow from the -30 to +10 degree orientation was 2.4 percent, which was less than the efficiency increases.

A test value for equivalent flow within three percent of predicted is considered close agreement for this small-size turbine with a 3-inch mean diameter, considering the difficulties involved in fabrication and inspection of the small nozzle, rotor passages, and throat openings.

Figure 30
2 STAGE PARTIAL ADMISSION TURBINE
 TEST 11, DESIGN CONFIG., DESIGN NEQ

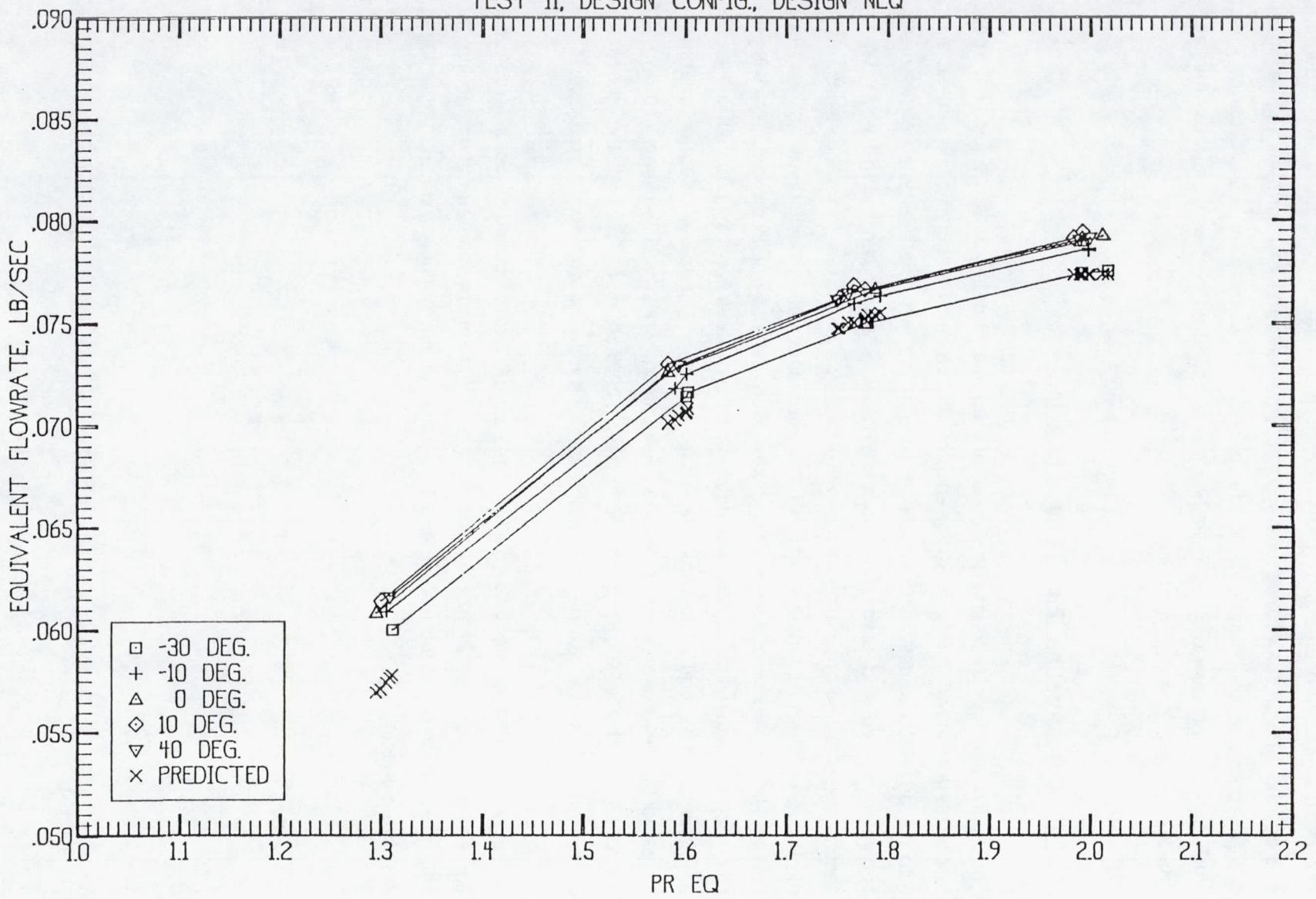
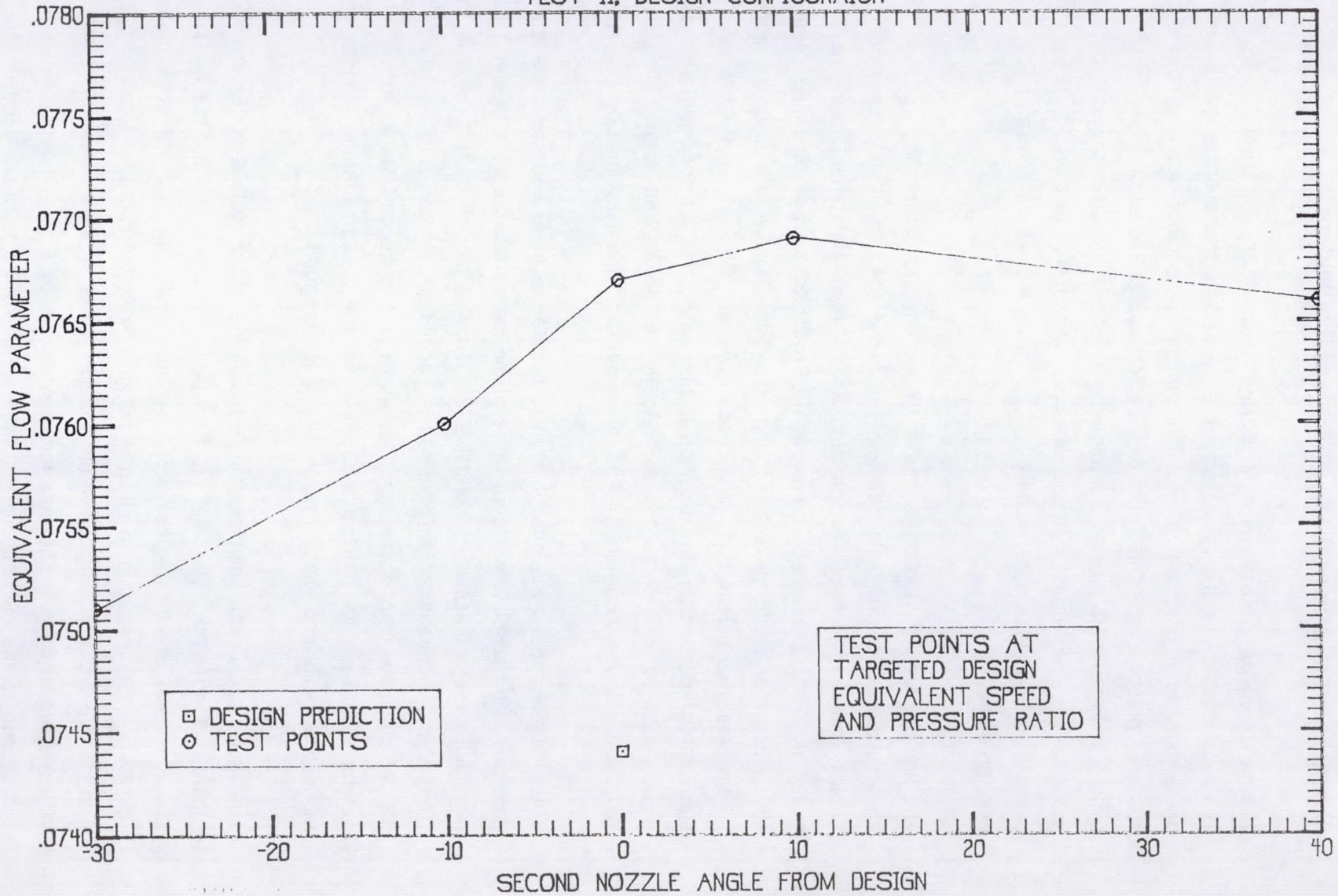

Figure 31

2 STAGE PARTIAL ADMISSION TURBINE
TEST 11, DESIGN CONFIGURATION



Design Configuration Static Pressure Distribution

The measured static pressures were averaged at each of the locations listed in **Table 8**. The local absolute static pressures were divided by the average inlet manifold test pressure to form pressure ratios. The test pressure ratios were compared with the predicted pressure ratios in **Table 8**. The test and predicted pressure ratios were also plotted in **Figure 32**. Good agreement was shown between the test data and the predictions. The largest delta (difference) ratio in **Table 8** was 0.039, or about 5 percent, for the first stage nozzle outlet hub pressure, which showed good agreement with predictions.

The test pressure distribution results confirmed that the design staging achieved a near equal available energy split between the two stages for high overall performance. Similar magnitude effects of the high nozzle outlet tangential swirl (tip pressures higher than hub pressures) are shown in **Figure 32** for both first and second stage nozzle active arcs and for both test and prediction. Positive test pressure drops shown for tip pressures across both rotor blade rows and for hub pressures across the first stage rotor indicated positive reaction in the active arcs for good performance. Near equal pressures were present in the inactive arcs across both rotors. This resulted in low blade and disk axial thrust loads, characteristic of partial admission staging.

The circumferential variations of a large number of measured static pressures were analyzed using absolute pressure ratios of the local static pressure divided by the inlet manifold average pressure to normalize the data. A plot of the test pressure ratios for the design configuration at the zero degree second stage nozzle angle is found in **Figure 33**, which shows the distributions for the first and second stage nozzle inlets and outlets. Data shown in **Figure 33** were for the instrumentation that survived the fabrication, build, and installation phases of the program.

The first stage nozzle inlet pressure ratios were shown with a larger scale than the others in **Figure 33**. The inlet manifold pressure ratio was 1.00, but the inactive arc pressure ratio at 180 degrees from the inlet pipe indicated a slightly higher value (1.015) due to the stagnation effect of being opposite the inlet pipe location (0 degrees). The inactive arc pressure ratio at the location where the inlet pipe entered the manifold was a value of 0.976. The hub values were slightly higher (1.3 percent) than the tip values due to the curvature of the inlet manifold into the first stage nozzle. These differences increased with flowrate (overall pressure ratio) from 1.3 to 2.0. Pressure

Table 8. Interstage Static Pressure Distribution Ratios, Design Configuration

COMPARISON OF TEST (TEST 8, LINE 10) AND PREDICTION

LOCATION	PRESSURE RATIO	TEST	PREDICTED	DELTA (PRED.-TEST)
PT1 INLET TOTAL PRESSURE, PSIA =		212.6	3747.3	- - -
N-1 INLET. - TIP/PT1		0.977	0.989	+0.012
N-1 INLET. - HUB/PT1		0.990	0.989	-0.001
N-1 INLET. - INACTIVE ARC/PT1		0.996	1.000	+0.004
N-1 OUTLET. - TIP/PT1		0.807	0.792	-0.015
N-1 OUTLET. - HUB/PT1		0.768	0.729	-0.039
N-1 OUTLET. - INACTIVE ARC/PT1		0.738	0.767 (1)	+0.029
N-2 INLET. - TIP/PT1		0.746	0.762	+0.016
N-2 INLET. - HUB/PT1		0.743	0.762	+0.019
N-2 INLET. - INACTIVE ARC/PT1		0.740	0.762 (1)	+0.022
N-2 INLET. - CAVITY/PT1		0.743	0.762 (1)	+0.019
N-2 OUTLET. - TIP/PT1		0.602	0.606	+0.004
N-2 OUTLET. - HUB/PT1		0.576	0.547	-0.029
N-2 OUTLET. - INACTIVE ARC/PT1		0.568	0.583 (1)	+0.015
R-2 OUTLET./PT1		0.571	0.579	+0.008

N-1 : FIRST STAGE NOZZLE

N-2 : SECOND STAGE NOZZLE

(1) MEAN GAS PATH PRESSURE

Figure 32

INTERSTAGE STATIC PRESSURE DISTRIBUTION AT DESIGN
(TEST 8, SLICE 10, AVERAGES OF MEASUREMENTS AT LOCATIONS)

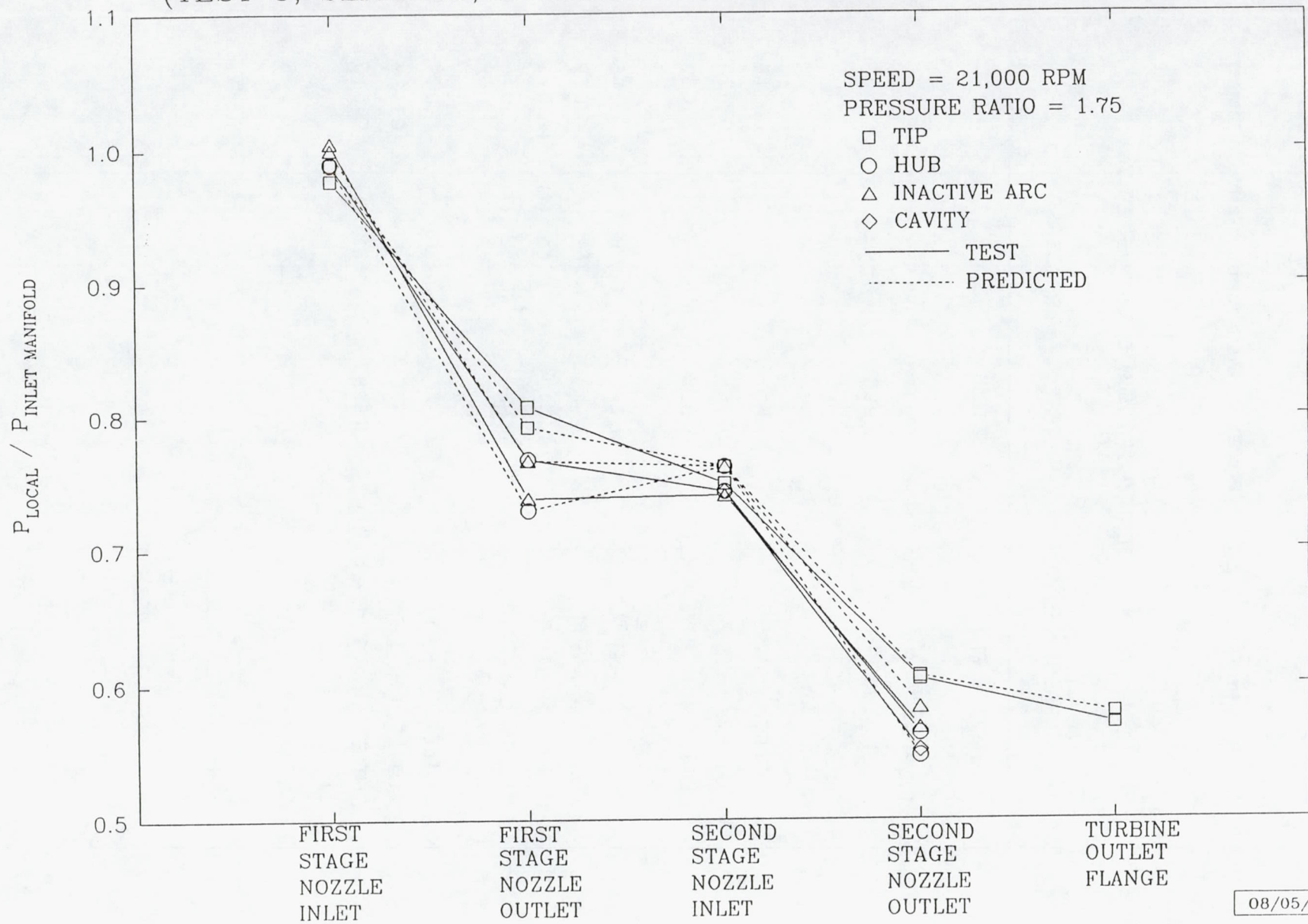
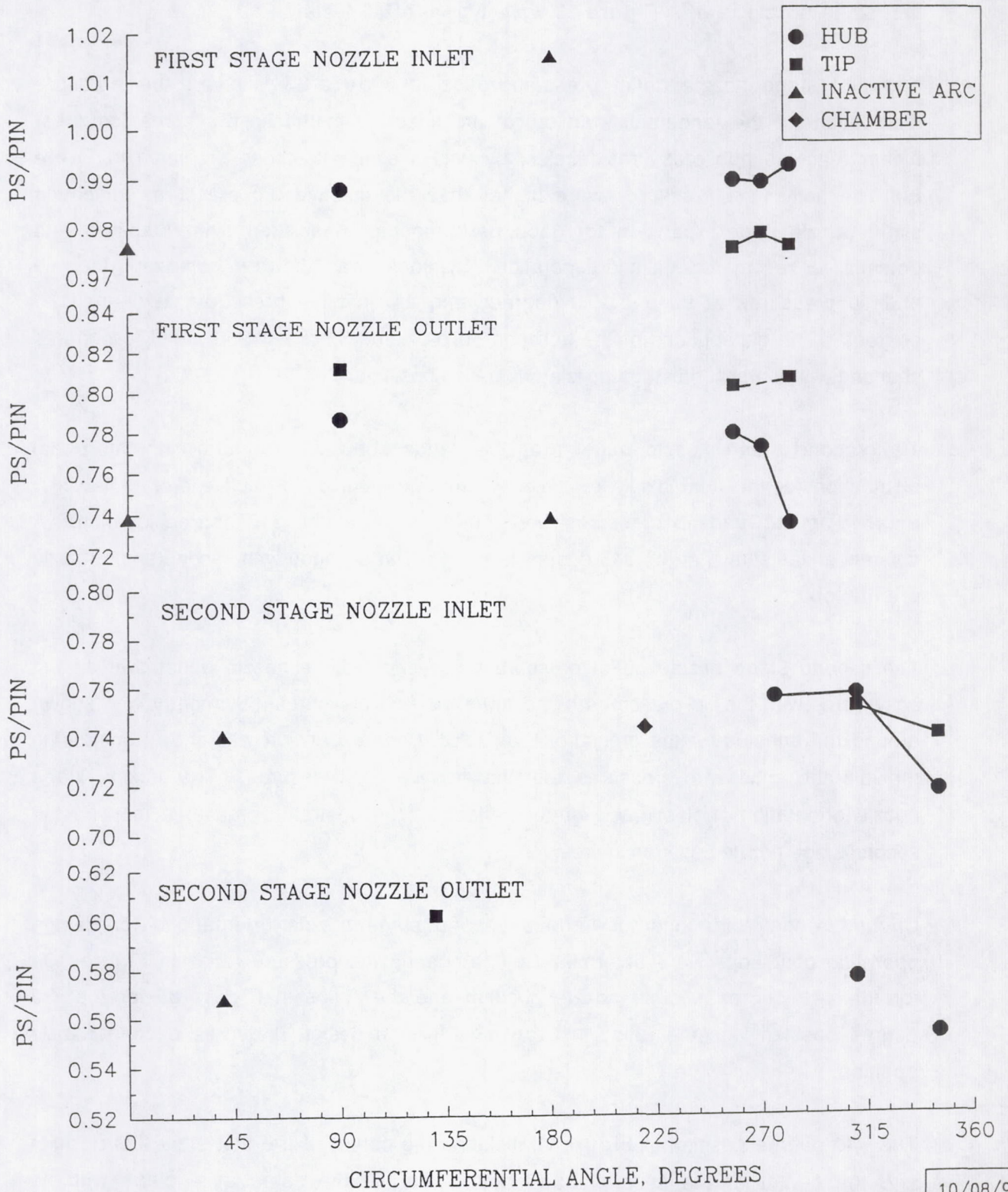

Figure 33

STATIC PRESSURE DISTRIBUTIONS
 DESIGN CONFIGURATION, 0 DEGREE SECOND NOZZLE
 TEST 8, LINE 10, 21086 RPM, 1.751 PRESSURE RATIO



10/08/92

Symmetry was shown for the two arcs of admission by comparing the hub pressure at 90 degrees with the hub pressure at 270 degrees. The distribution proportions for the first stage nozzle inlet in **Figure 33** were typical of all tests.

The first stage nozzle outlet pressure ratios in **Figure 33** showed the pressure distribution for the tangential swirl out of the nozzle with the tip pressures (squares) higher than the hub pressures (circles) by values similar to those predicted in **Table 8**. The active arc pressures were higher than the inactive arc pressures indicating slight nozzle underexpansion for good performance rather than overexpansion with potential for recompression and separation. Symmetry was shown in comparing the hub and tip pressures at 90 and 270 degrees and the inactive pressures at 0 and 180 degrees. The distributions of the hub and tip pressures between 250 and 270 degrees changed with the second stage nozzle orientation position.

The second stage nozzle outlet pressure ratios showed a uniform circumferential distribution for the near axial, low velocity head flow out of the active arcs of the first rotor. The hub and tip pressures were nearly equal at the 310 degree location. A difference was shown at the 345 degree location which changed with second stage nozzle orientation.

The second stage nozzle outlet pressure ratios showed the nozzle outlet swirl in the active arcs with the tip pressures higher than the hub pressures. Symmetry was shown around the annulus for the pressures available. Underexpansion was shown comparing the average active arc pressures with the inactive arc pressures. The second stage nozzle orientation angles had a greater effect on the upstream pressures than on the second stage nozzle outlet pressures.

Circumferential variations for various second stage nozzle orientations for design operating conditions were determined by comparing the pressure ratios in **Figures 34** for the +40 degree second nozzle position and the ratios in **Figure 35** for the -30 degree position with the ratios in **Figure 33** for the design 0 degree second nozzle position.

The +40 degree position in **Figure 28** included the center of the first stage nozzle inlet and the center of the second stage nozzle inlet in the same axial plane with no circumferential offset. In the -30 degree position at the bottom of **Figure 28**, significant circumferential offset was present (70 degrees in the direction of rotation)

Figure 34

STATIC PRESSURE DISTRIBUTIONS
DESIGN CONFIGURATION, +40 DEGREE SECOND NOZZLE
TEST 8, LINE 9, 21096 RPM, 1.754 PRESSURE RATIO

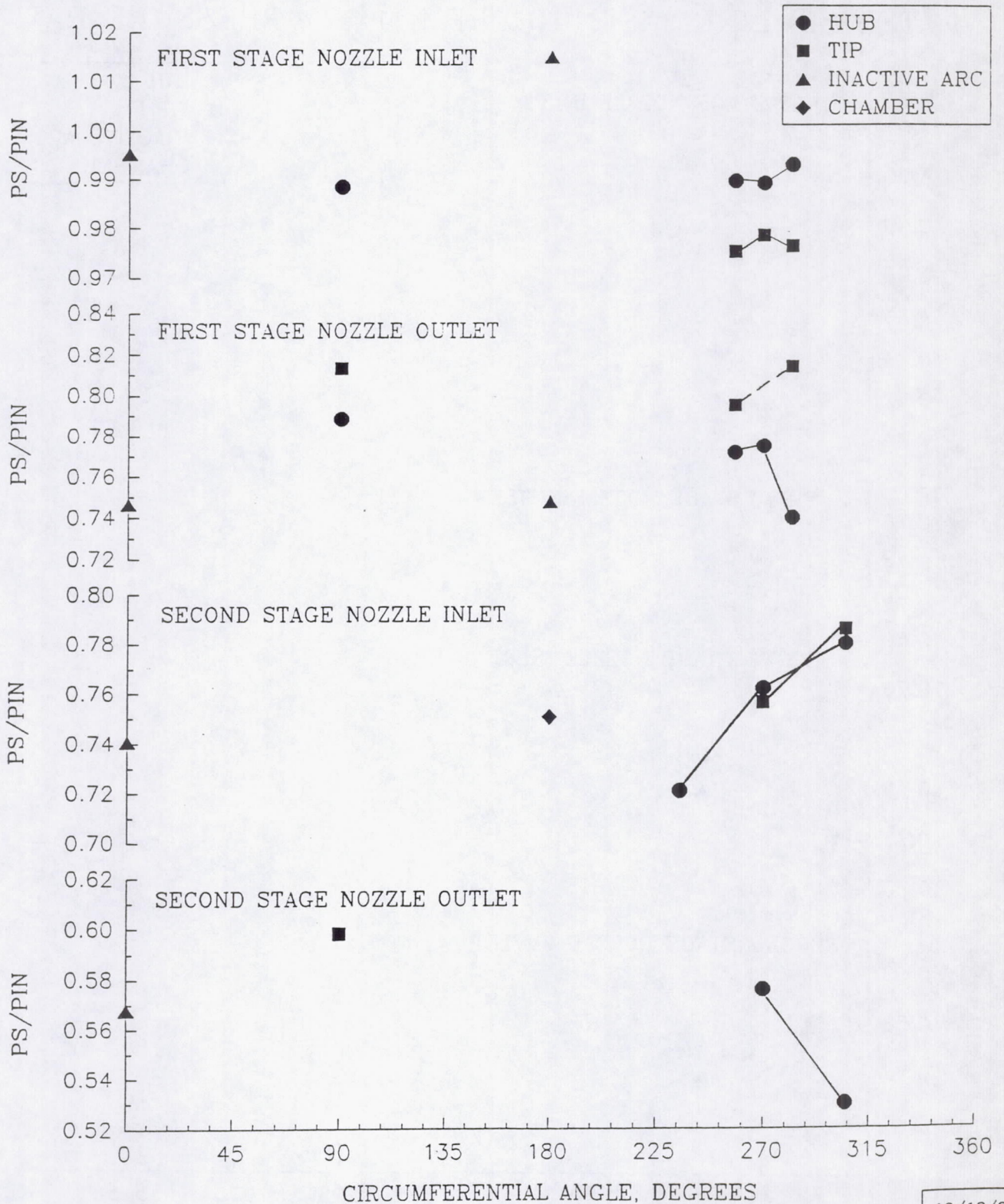

10/19/92

Figure 35

STATIC PRESSURE DISTRIBUTIONS
 DESIGN CONFIGURATION, -30 DEGREE SECOND NOZZLE
 TEST 8, LINE 14, 21101 RPM, 1.777 PRESSURE RATIO

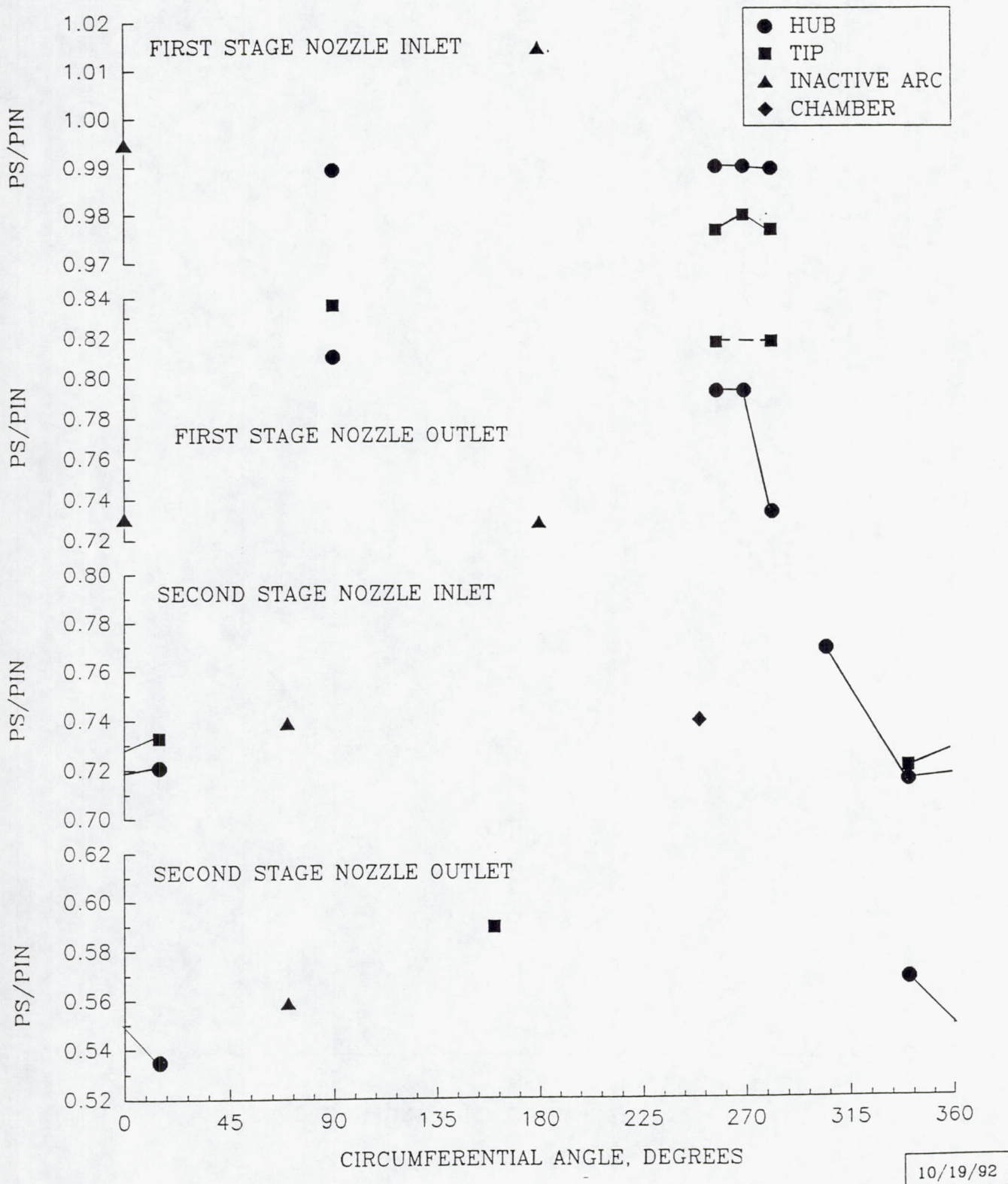

10/19/92

with almost no overlap of the first stage nozzle inlet arc with the second stage nozzle inlet arc.

The design second stage nozzle position at 40 degree circumferential offset was between the two extremes tested. Since a flow molecule traverses circumferentially in the direction of rotation in passing through the turbine, highest performance is achieved when the second stage nozzle inlet is positioned to most efficiently capture the kinetic energy leaving the first stage active arcs of admission. Highest test efficiency was shown for the +10 degree second stage nozzle orientation with only a slight reduction for the +40 degree orientation.

The first stage nozzle inlet and second stage nozzle outlet pressure ratios did not show significant changes for the second stage nozzle orientations. However, the active arc distributions at the first stage nozzle outlet and at the second stage nozzle inlet did show the effects of the second stage nozzle orientation changes.

The first stage nozzle outlet tip pressure ratios increased from the 258 degree to the 282 degree angles due to the effective blockage with no offset for the + 40 degree second nozzle position in **Figure 34** compared with **Figure 33** for the design 0 degree position. The hub pressures at 310 degree and 345 degree angles were also higher for the same reason. The second stage nozzle inlet pressure ratios at both the hub and tip exhibited an increasing trend from 235 to 305 degrees for the +40 second stage nozzle position in **Figure 34**. The higher velocity head and lower static pressures are shown for the +40 second stage nozzle in **Figure 34**, lower than the inactive arc pressures.

Comparing the -30 degree, high offset, second stage nozzle orientation in **Figure 35** with the design in **Figure 33**, less increase was shown for the tip pressures at the first stage nozzle outlet from 258 degrees to 282 degrees for the - 30 degree second stage nozzle. The lower value at 282 degrees indicated a lower resistance with the higher offset. The second stage nozzle inlet pressure ratios were lower at the 305 degree and 340 degree angles indicating lower pressures required to pass the flow beyond the range of kinetic energy from the first stage.

The circumferential variations with shaft speed at the design pressure ratio and second nozzle orientation are shown in **Figure 36** for the test at 10,052 RPM and in **Figure 37** for the test at 25,003 RPM. The 25,003 RPM test compared closely with

Figure 36

STATIC PRESSURE DISTRIBUTIONS
 DESIGN CONFIGURATION, 0 DEGREE SECOND NOZZLE
 TEST 8, LINE 82, 10052 RPM, 1.759 PRESSURE RATIO

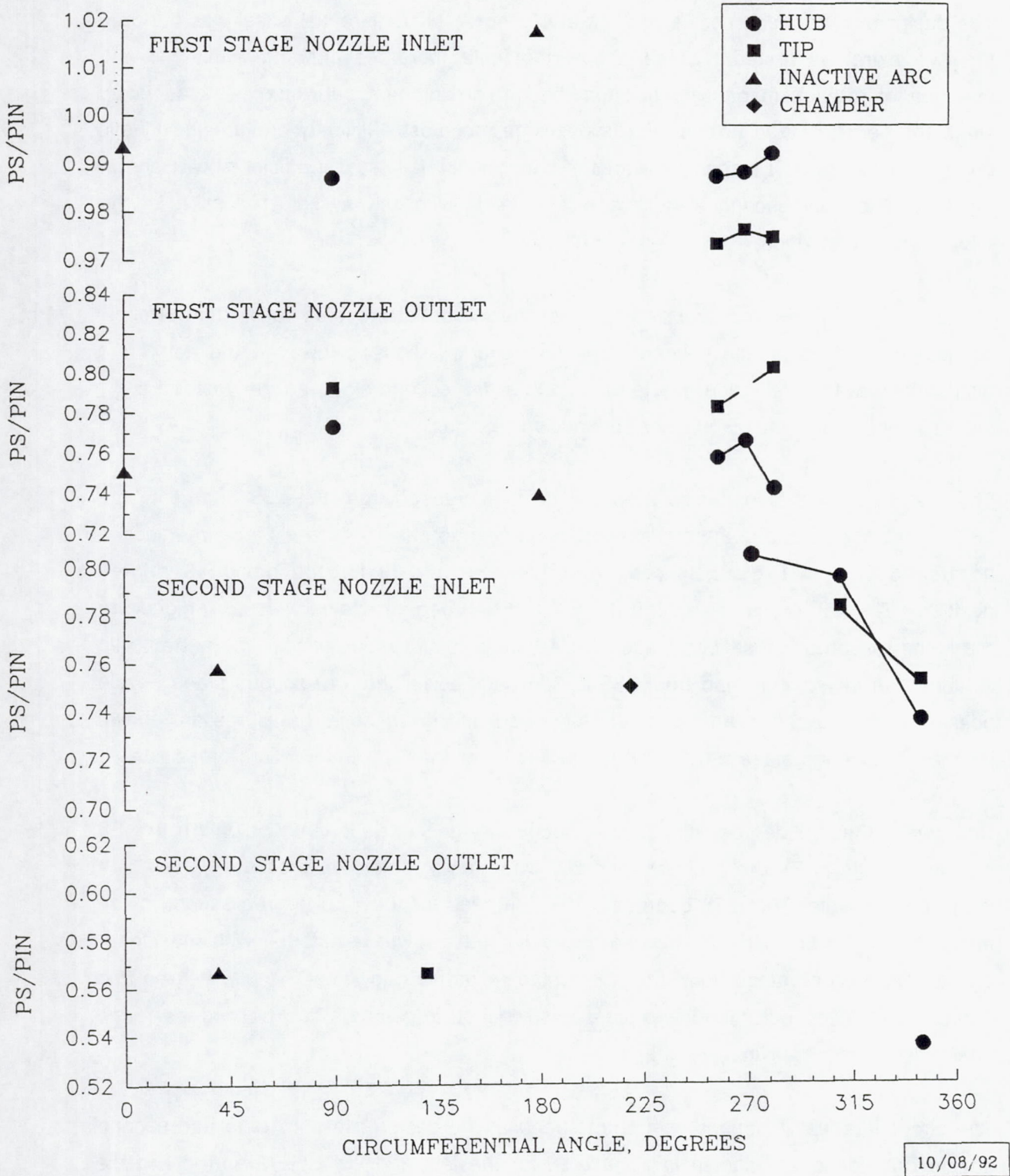

10/08/92

Figure 37

STATIC PRESSURE DISTRIBUTIONS
 DESIGN CONFIGURATION, 0 DEGREE SECOND NOZZLE
 TEST 8, LINE 57, 25003 RPM, 1.741 PRESSURE RATIO

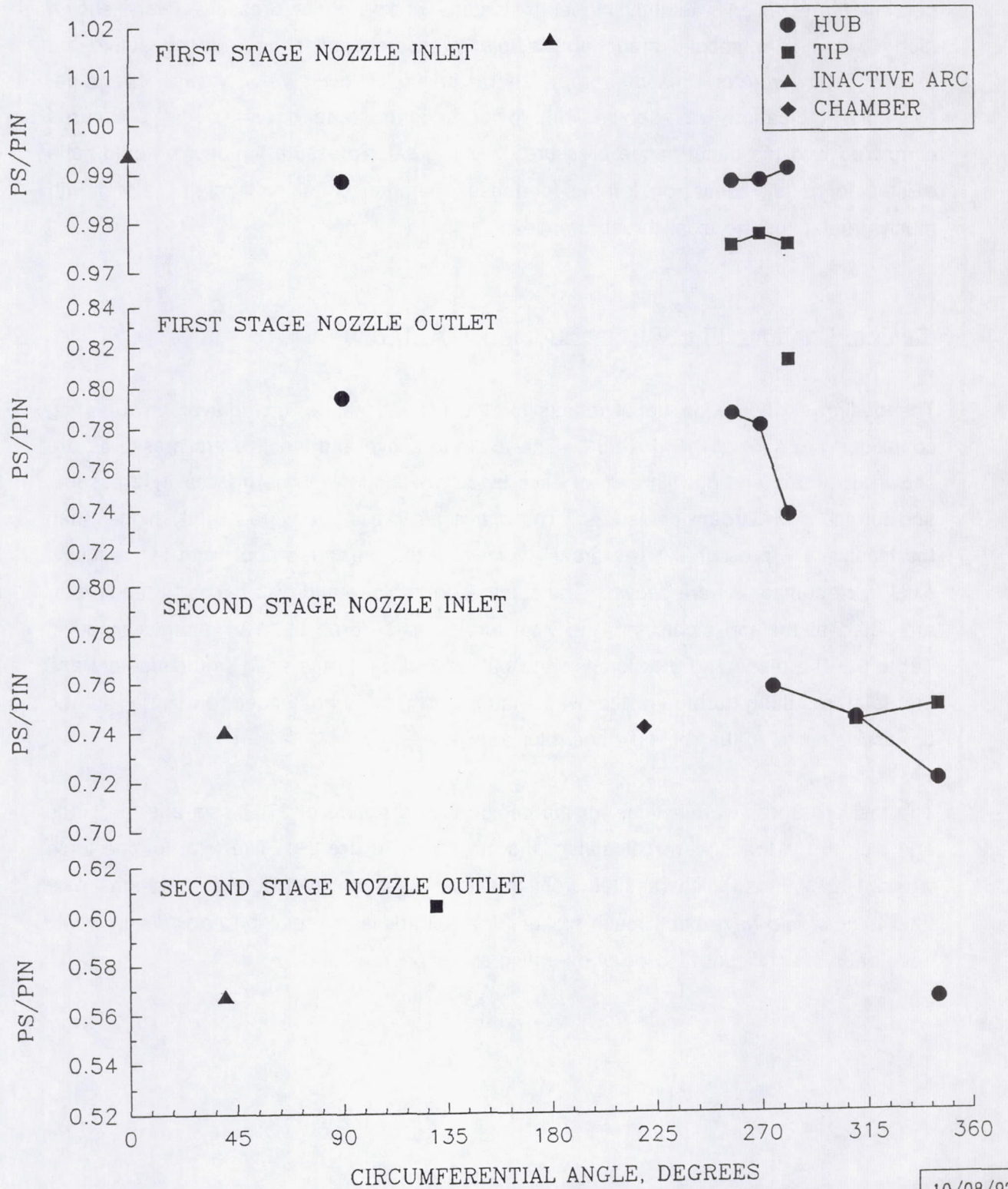

10/08/92

the design speed test in **Figure 33**. The overall velocity change from design was less than 20 percent. The velocity ratio change for the 10,052 RPM test was down 60 percent from design. Slightly higher first stage nozzle outlet pressures were shown along with higher second stage nozzle inlet pressures indicating reduced active arc reactions (lower rotor pressure drop), characteristic of lower velocity ratio operation. A similar indication was shown with lower second stage nozzle outlet pressures compared with the outlet flange pressure. Much greater pressure variations would have existed for a full admission turbine for these operating condition changes along with much greater turbine axial thrust changes.

Design Configuration Turbine Rotor Axial Thrust

The design configuration detail results for the test at the design equivalent operating conditions are shown in **Figure 38**. The average active and inactive arc pressures are shown upstream and downstream of each blade row along with the disk cavity pressures and turbine downstream pressures. The active arc pressures were slightly higher than the inactive arc pressures. The areas over which the pressures apply and the resulting axial force component are shown. The summation of blade and disk forces for each rotor are listed at the top along with the total turbine axial force of 119.7 pounds listed in **Table 6**. The blade and disk forces were balanced down to the shaft seal diameters and the total resulting turbine force was mainly from the unbalanced pressure on the downstream side of the second stage rotor disk.

The test pressures were ratioed for the design inlet pressure of 3747 psia and the blade and disk thrust loads were calculated and shown in **Figure 39**. The total turbine force was 2,109 pounds which resulted from the high pressure level during operation. The total force would have been much higher for a full admission reaction turbine and would have been a significant function of operating shaft speed.

Figure 38 Axial Thrust From Pressure Loads

Design Configuration , Design Conditions, 0 Deg Second Nozzle (Test 8, Line 10)

Test Pressures for Inlet Pressure of 212.65 Psia

TOTAL TURBINE FORCE, LBf 119.7 ←

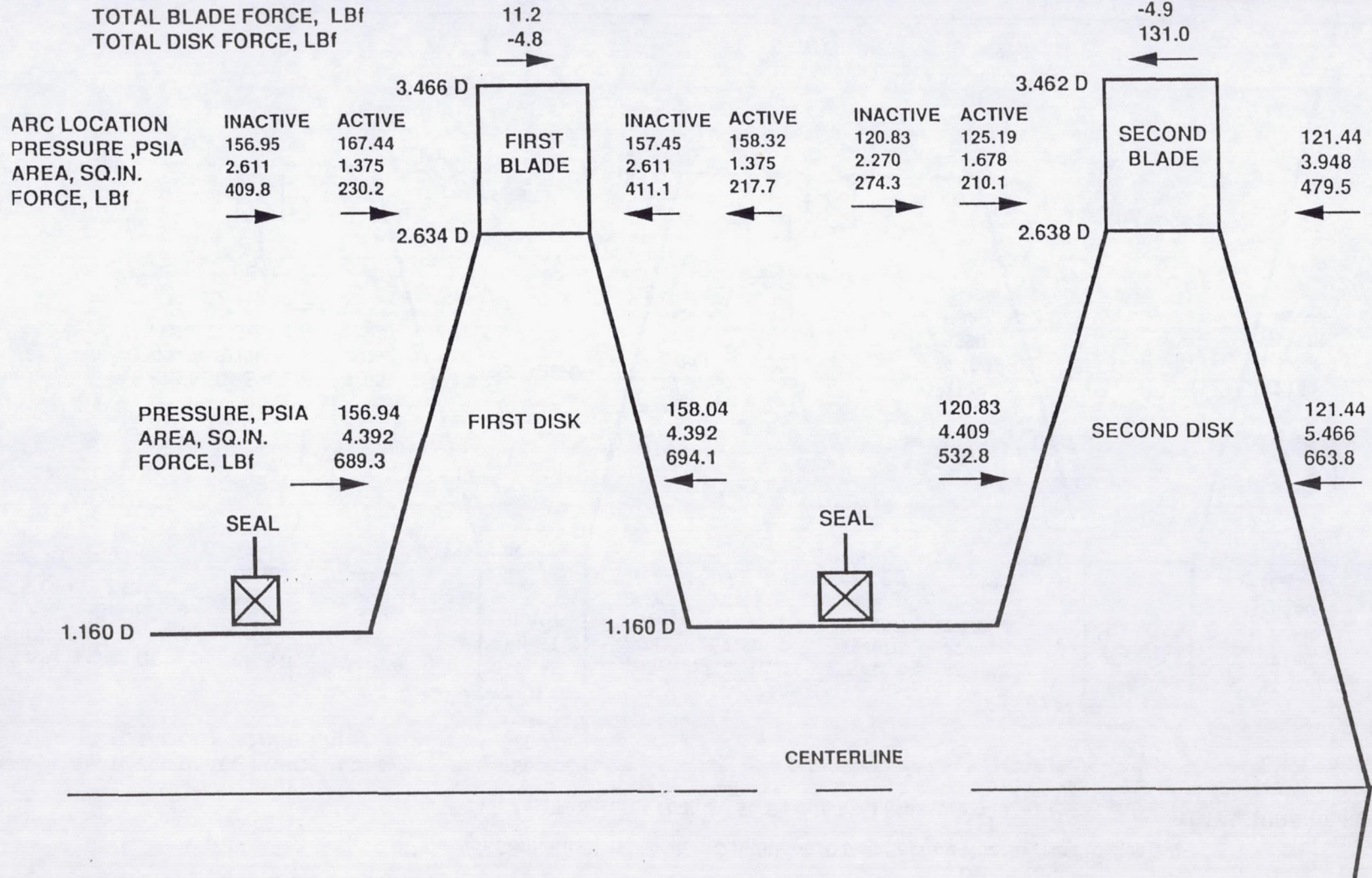

- 67 -

Figure 39

Axial Thrust From Pressure Loads

Design Configuration , Design Conditions, 0 Deg Second Nozzle (Test 8, Line 10)

Test Pressures Ratioed To Design Inlet Pressure of 3747 Psia

TOTAL TURBINE FORCE, LBf 2109

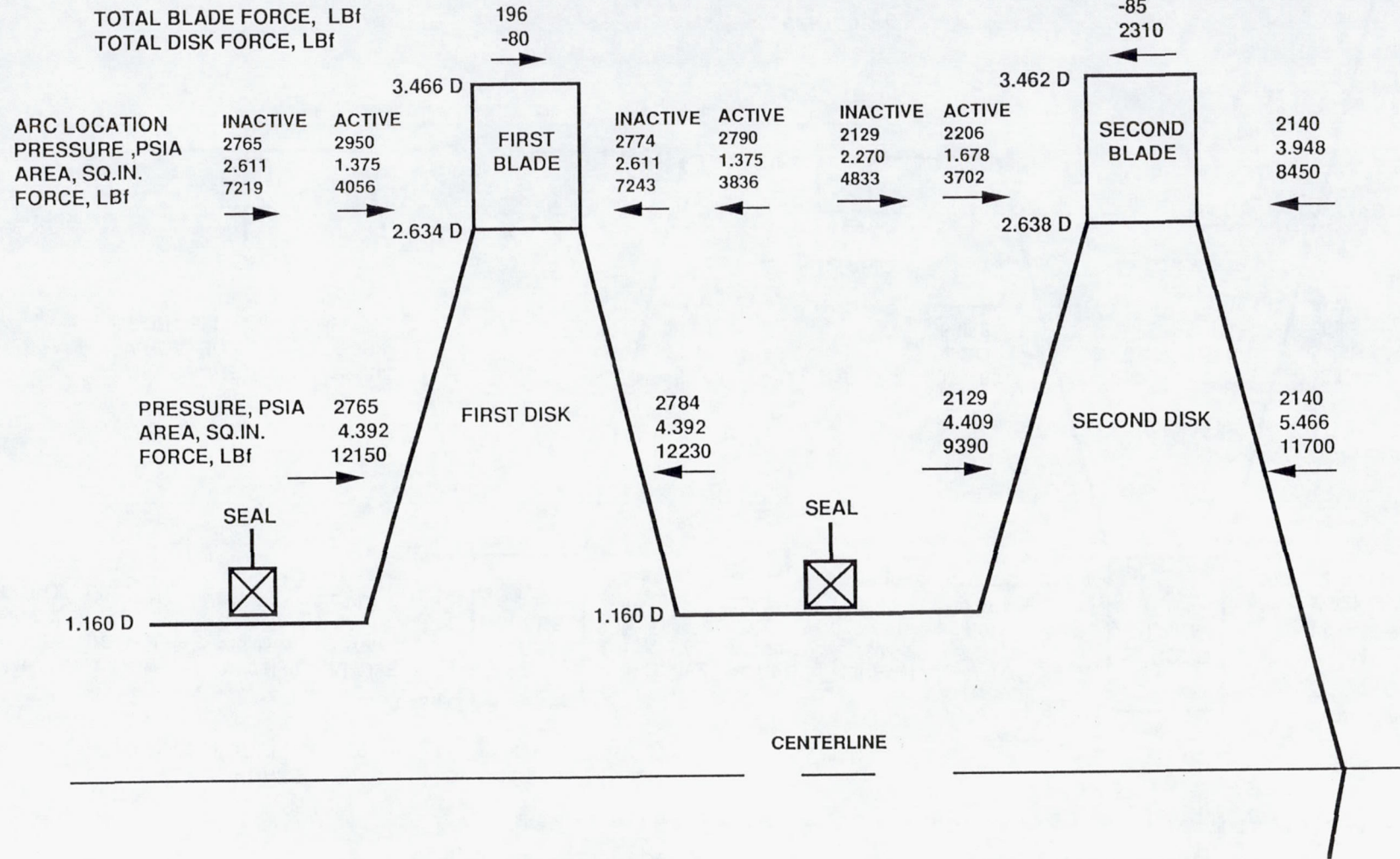

- 68 -

HALF DESIGN ADMISSION CONFIGURATION

The half design admission configuration included a first stage admission of 13.8 percent with 4 of 29 nozzles flowing, two per half 180 degrees apart, and a second stage nozzle admission of 19.4 percent with 6 of 31 nozzles flowing, three per half 180 degrees apart. The ratio of second stage nozzle admission to first stage nozzle admission was 1.406, compared with 1.310 for the design admission configuration. The half design configuration was the ideal design for a turbine application with a lower specific speed than the design admission configuration. Reasons for this are lower flowrate, lower admission, higher pressure and higher second to first stage nozzle admission ratios for a turbine with a near equal stage power split, and potentially lower speed for the lower peak efficiency from reduced admission.

Half Configuration Efficiency Characteristic

The best fit efficiency curves for the 5 second stage nozzle orientation angles are shown in **Figure 40**. A lower peak efficiency was shown for the smaller arc of admission with a lower peak efficiency velocity ratio compared with the design admission configuration. A greater variation in efficiency existed for the range of second stage nozzle orientation angles. Relatively high efficiencies were shown in these figures for the tests with pressure ratios of 2.0. A pressure ratio of 2.0 was used as the reference for analyses of the half design admission configuration, rather than the design pressure ratio of 1.765, because of the higher second to first stage nozzle admission ratio. Parameters for the prediction, test points for the targeted design equivalent speed of 21,219 RPM, and the equivalent pressure ratio of 2.0 are listed in **Table 9** for the 5 second stage nozzle angles. These efficiencies were plotted versus second stage nozzle angle in **Figure 41**, along with the gas path program prediction. A much more significant effect from the second stage nozzle orientation was shown for the half design admission compared to the design admission configuration. An efficiency increase of 21 percent, 8.5 percentage points, was shown from the -30 degree orientation to the +30 degree orientation. The predicted efficiency was plotted at the design second stage nozzle 0 degree position, and was 7.3 percent higher than the test value. The efficiency for the +30 degree orientation was 3.7 percent lower than the prediction.

Figure 40
 2 STAGE PARTIAL ADMISSION TURBINE
 EFFICIENCY VS U/CO

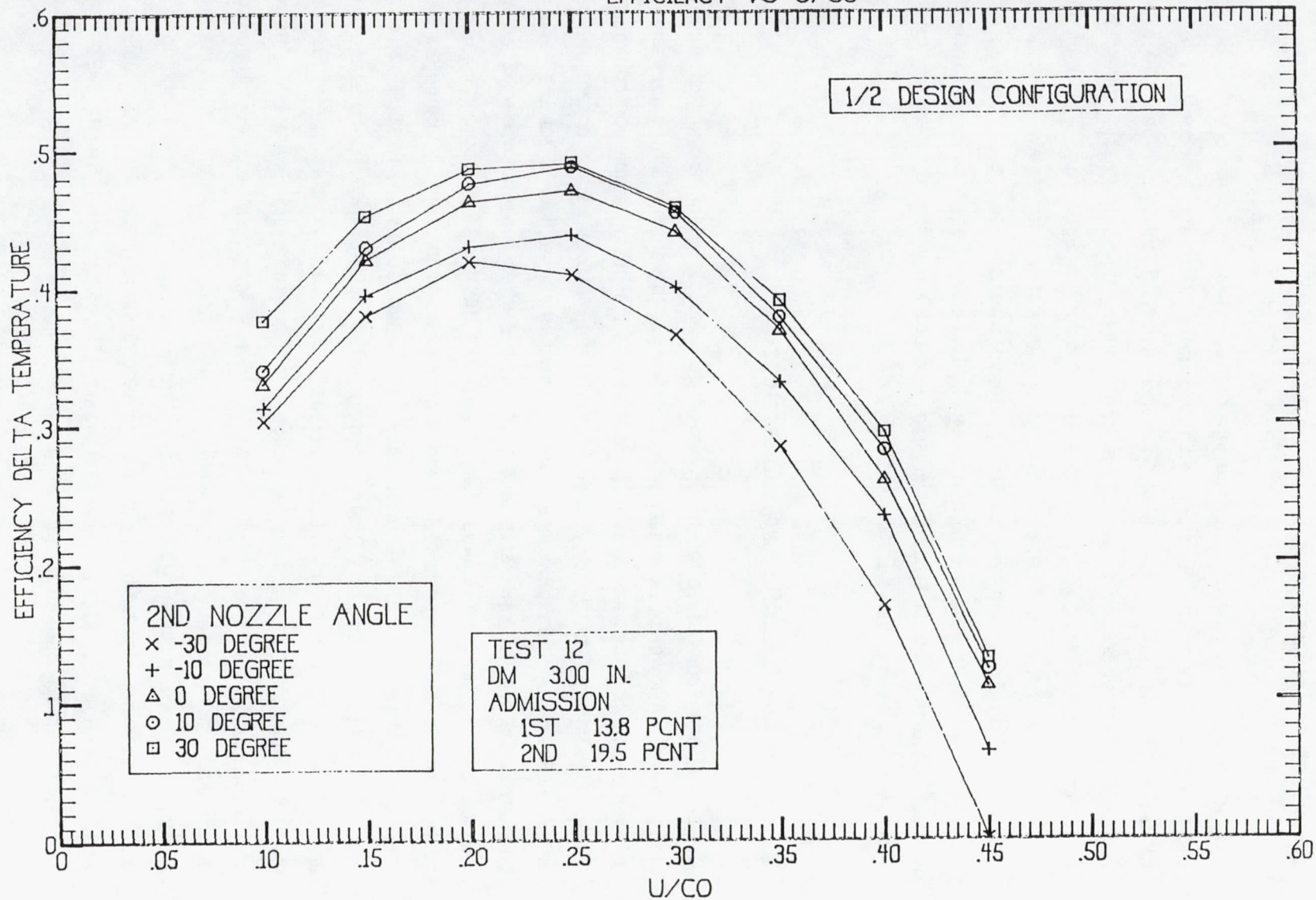

- 70 -

Table 9

TARGET N (eq) AND PR (eq)
 $\frac{1}{2}$ DESIGN ARC OF ADMISSION

2-N ANGLE, DEGREES	LINE NUMBER TEST 12	N (eq) RPM	PR (eq)	FLOW (eq) LB/SEC	EFFICIENCY (ETA)	Um/Co
0	PREDICTED	21219	2.000	0.0313	0.513	0.2662
-30	50	21563	1.985	0.0318	0.409	0.272
-10	54	21553	2.009	0.0321	0.437	0.270
0	61	21375	1.999	0.0325	0.478	0.268
+10	41	21259	1.996	0.0326	0.491	0.267
+30	46	21403	1.999	0.0329	0.494	0.269

Figure 41
2 STAGE PARTIAL ADMISSION TURBINE
TEST 12, HALF DESIGN CONFIGURATION

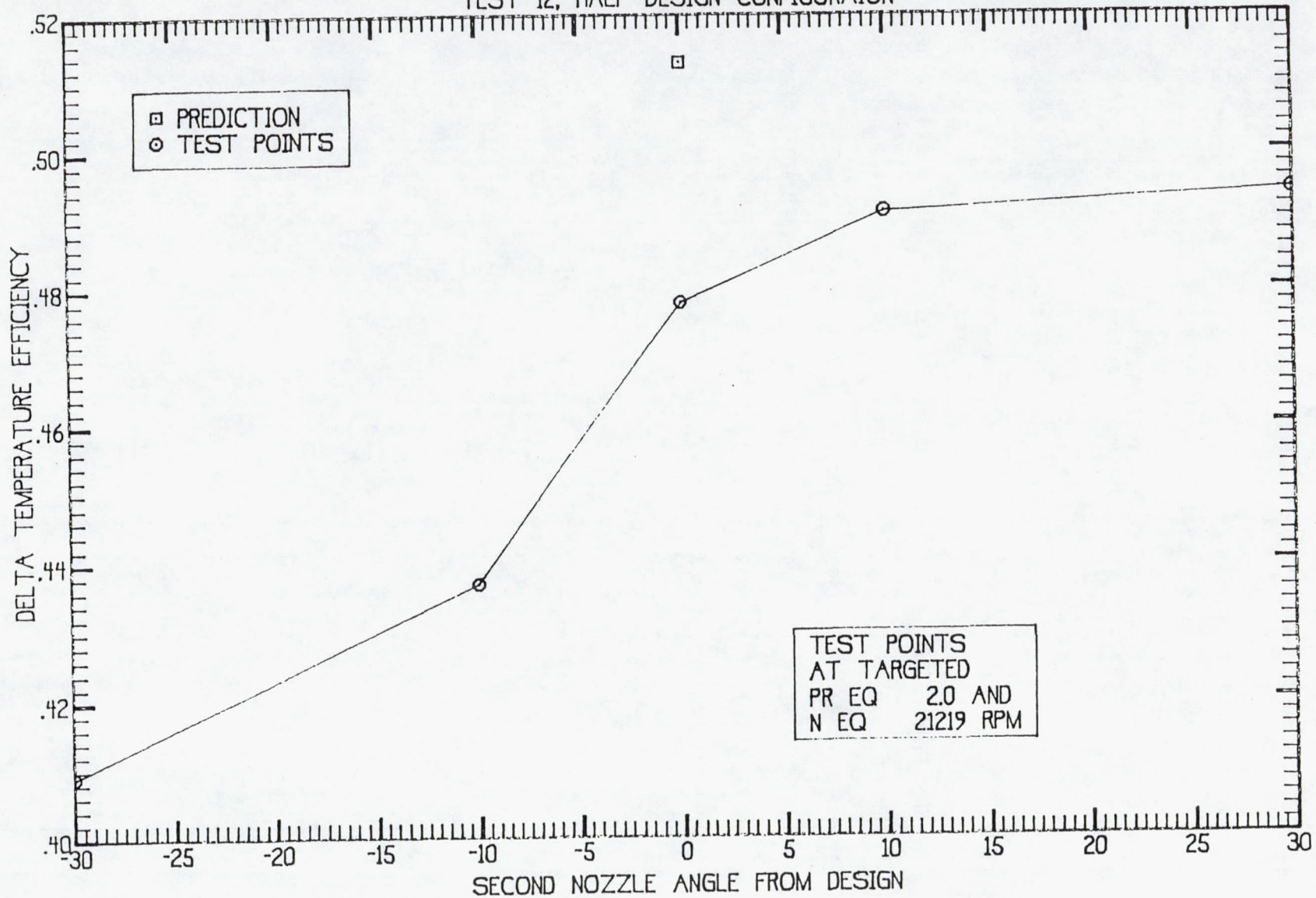

Half Configuration Flow Characteristic

The equivalent flow versus pressure ratio for the targeted design equivalent speed test points are shown in **Figure 42** for each of the 5 second stage nozzle orientation angles along with the predicted values. The equivalent flow for the test points targeted at the design equivalent speed of 21,219 RPM and pressure ratio of 2.0 from **Table 9** are shown in **Figure 43** versus second stage nozzle orientation along with the prediction. The equivalent flow at the 0 degree design orientation was 3.8 percent higher than predicted. An increased equivalent flow of 3.1 percent was shown from -30 degrees to +30 degrees. The efficiency also increased with increasing nozzle orientation angle, with the optimum (beyond which efficiency and flow decrease) appearing higher than the +30 degrees tested.

Half Configuration Static Pressure Distribution

The average static pressures measured at each interstage location were averaged and compared with the predictions for the design equivalent test conditions in **Figure 44** and in **Table 10**. Good agreement of the test data with the prediction was shown. The largest deviation was for the first stage nozzle outlet hub pressure with a delta ratio of 0.076, or about 11 percent. The higher first stage pressure ratio was consistent with the higher second-to-first-stage nozzle area ratio.

Half Configuration Turbine Rotor Axial Thrust

The average active and inactive arc test pressures are shown in **Figure 45**. The areas of active arc pressure were smaller for the half configuration. The areas and forces are also shown in **Figure 45**. The total turbine force was less than the design configuration because of the lower turbine outlet pressure. The pressures were scaled by the design inlet pressure in **Figure 46**. The total turbine force was 1912 pounds for the high design pressures.

Figure 42

2 STAGE PARTIAL ADMISSION TURBINE

TEST 12, 1/2 DESIGN CONFIG., DESIGN NEQ

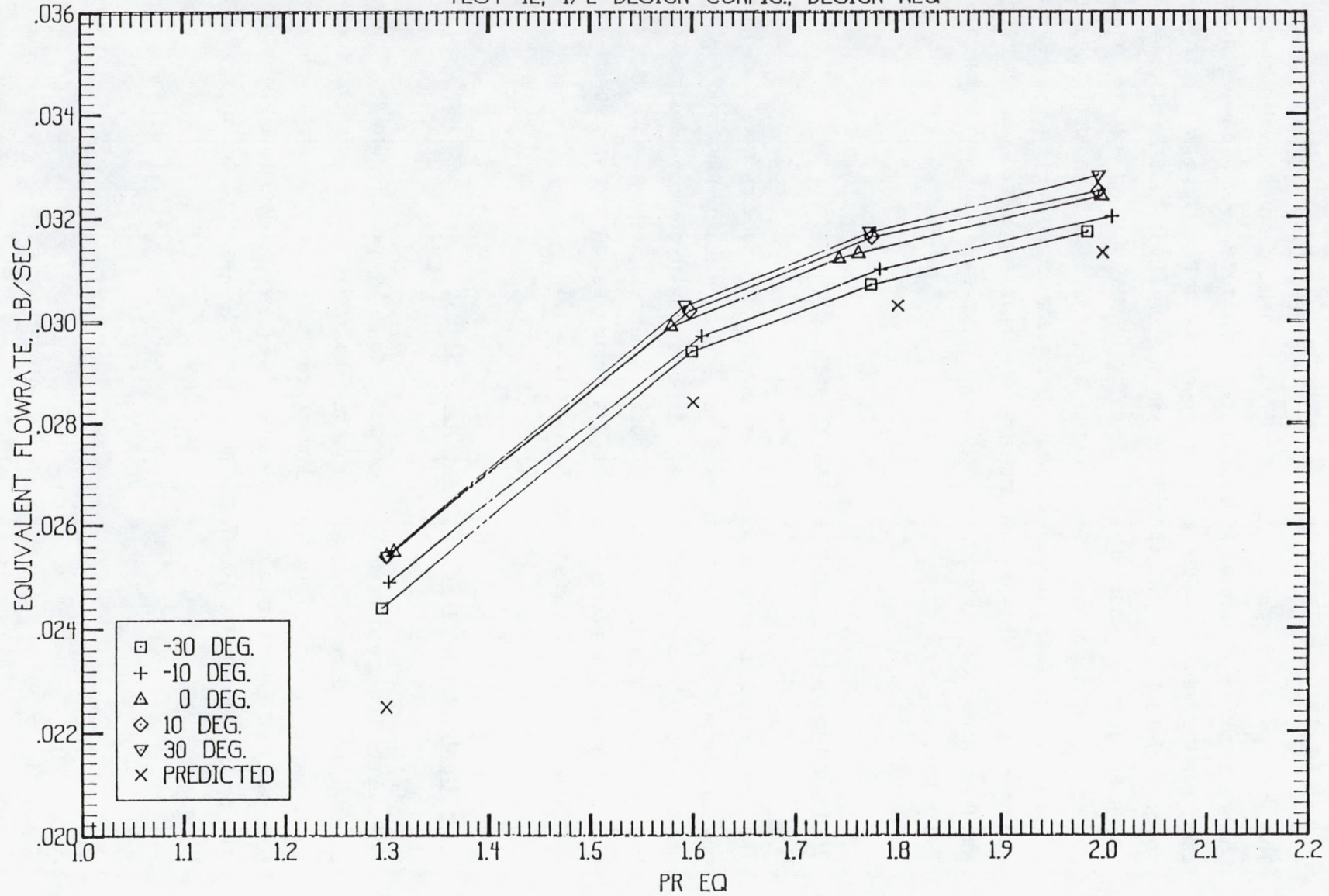

- 7 4 -

Figure 43

2 STAGE PARTIAL ADMISSION TURBINE
TEST 12, HALF DESIGN CONFIGURAION

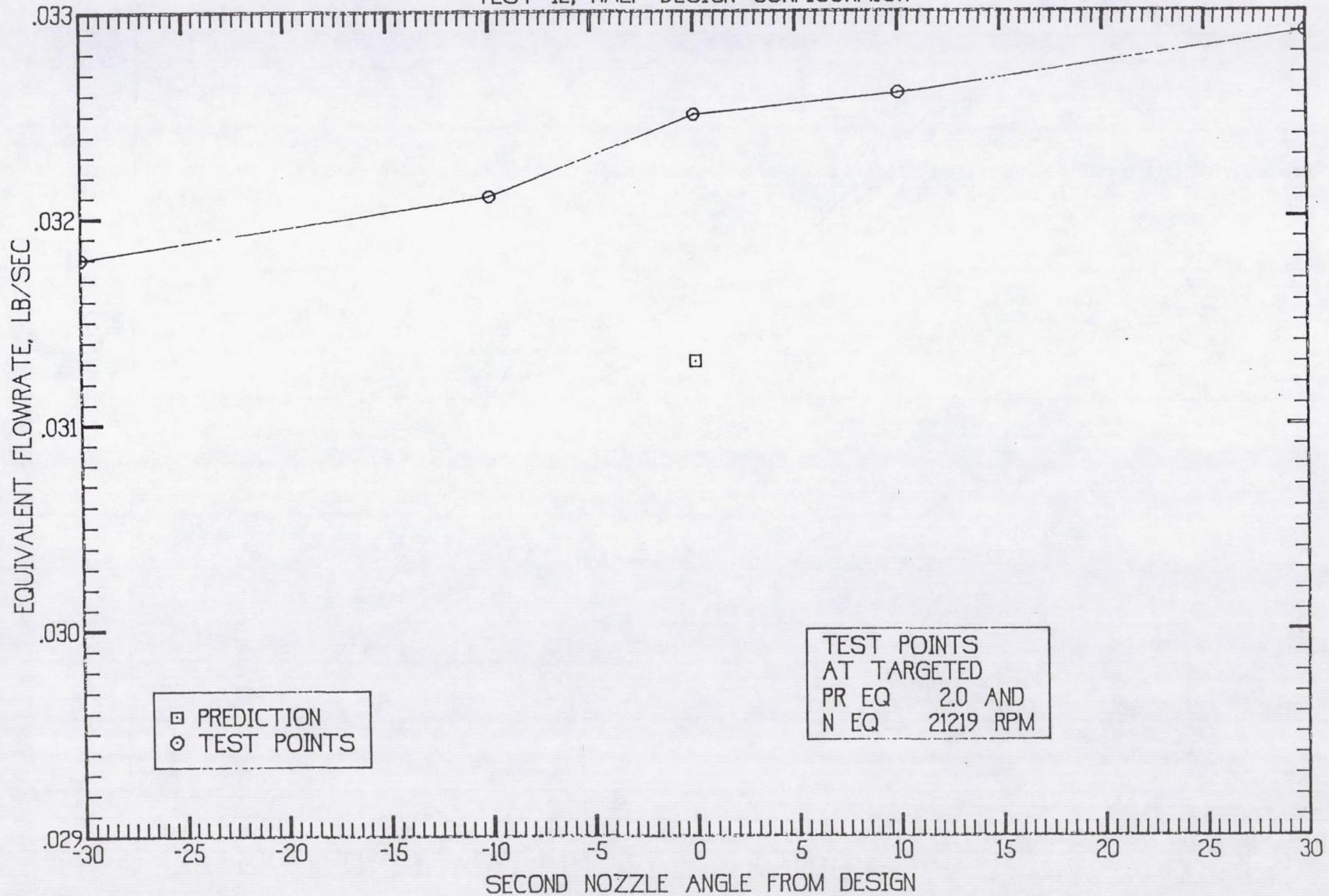

□ PREDICTION
○ TEST POINTS

TEST POINTS
AT TARGETED
PR EQ 2.0 AND
N EQ 21219 RPM

Figure 44

INTERSTAGE STATIC PRESSURE DISTRIBUTION AT HALF DESIGN
 (TEST 9, SLICE 10, AVERAGES OF MEASUREMENTS AT LOCATIONS)

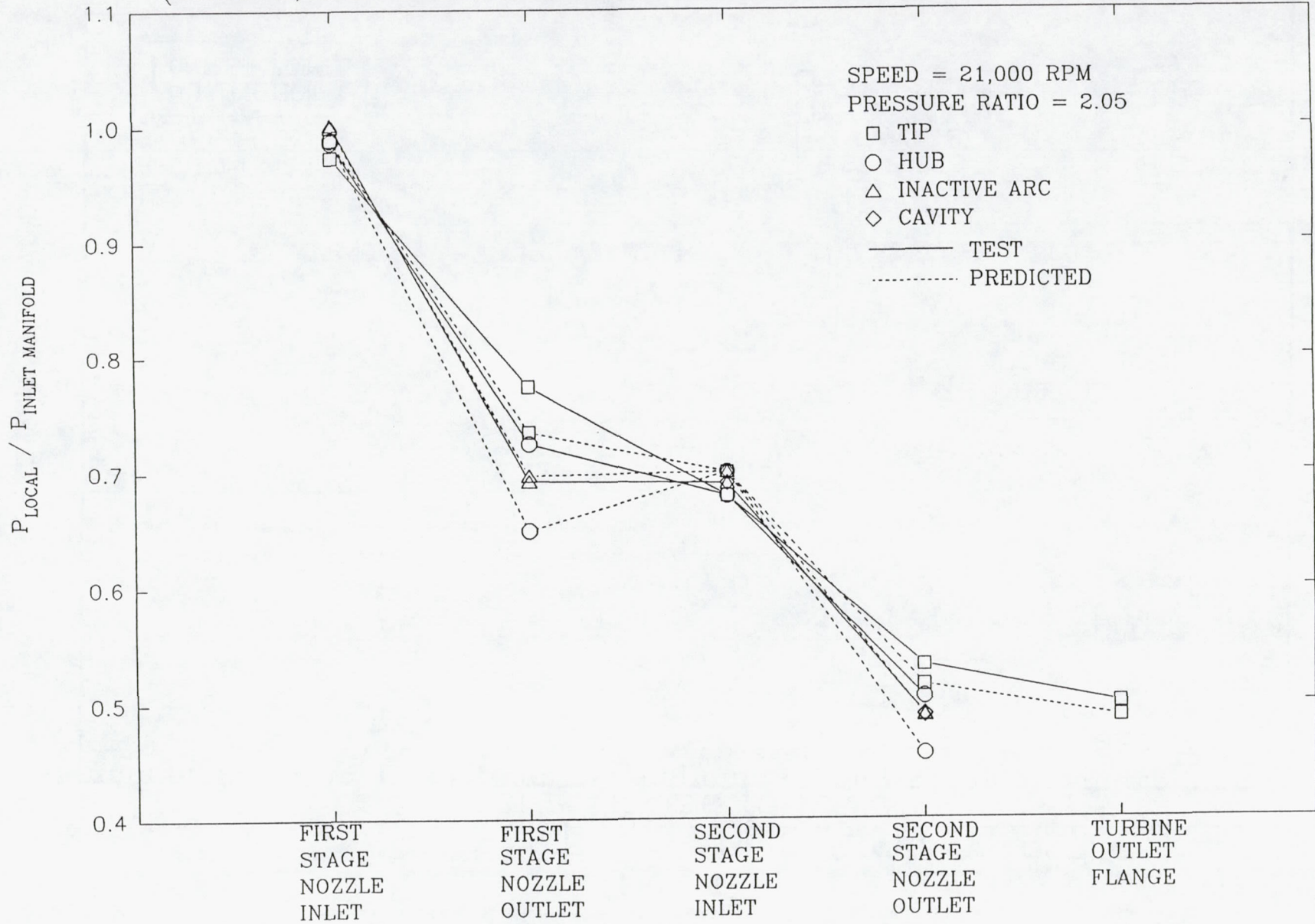

Table 10. Interstage Static Pressure Distribution Ratios, Half Design Configuration

COMPARISON OF TEST (TEST 9, LINE 10) AND PREDICTION

LOCATION	PRESSURE RATIO	TEST	PREDICTED	DELTA (PRED. - TEST)
INLET TOTAL PRESSURE (PT1), PSIA		213.4	3747.3	- - -
N-1 INLET - TIP/PT1		0.974	0.989	+0.015
N-1 INLET - HUB/PT1		0.987	0.989	-0.002
N-1 INLET - INACTIVE ARC/PT1		1.002	1.000	-0.002
N-1 OUTLET - TIP/PT1		0.774	0.735	-0.039
N-1 OUTLET - HUB/PT1		0.725	0.649	-0.076
N-1 OUTLET - INACTIVE ARC/PT1		0.692	0.697 (1)	+0.005
N-2 INLET - TIP/PT1		0.679	0.700	+0.021
N-2 INLET - HUB/PT1		0.679	0.700	+0.021
N-2 INLET - INACTIVE ARC/PT1		0.690	0.700 (1)	+0.010
N-2 INLET - CAVITY/PT1		0.690	0.700 (1)	+0.010
N-2 OUTLET - TIP/PT1		0.532	0.515	-0.017
N-2 OUTLET - HUB/PT1		0.505	0.456	-0.049
N-2 OUTLET - INACTIVE ARC/PT1		0.497	0.489 (1)	-0.008
N-2 OUTLET - CAVITY/PT1		0.490	0.489 (1)	-0.001
R-2 OUTLET/PT1		0.500	0.488	-0.012

N-1 : FIRST STAGE NOZZLE
 N-2 : SECOND STAGE NOZZLE
 (1) MEAN GAS PATH PRESSURE

Figure 45 Axial Thrust From Pressure Loads

Half Design Configuration, Design Conditions, 6 Deg Second Nozzle (Test 9, Line 10)

Test Pressures for Inlet Pressure of 213.44 Psia

TOTAL TURBINE FORCE, LBf 108.9

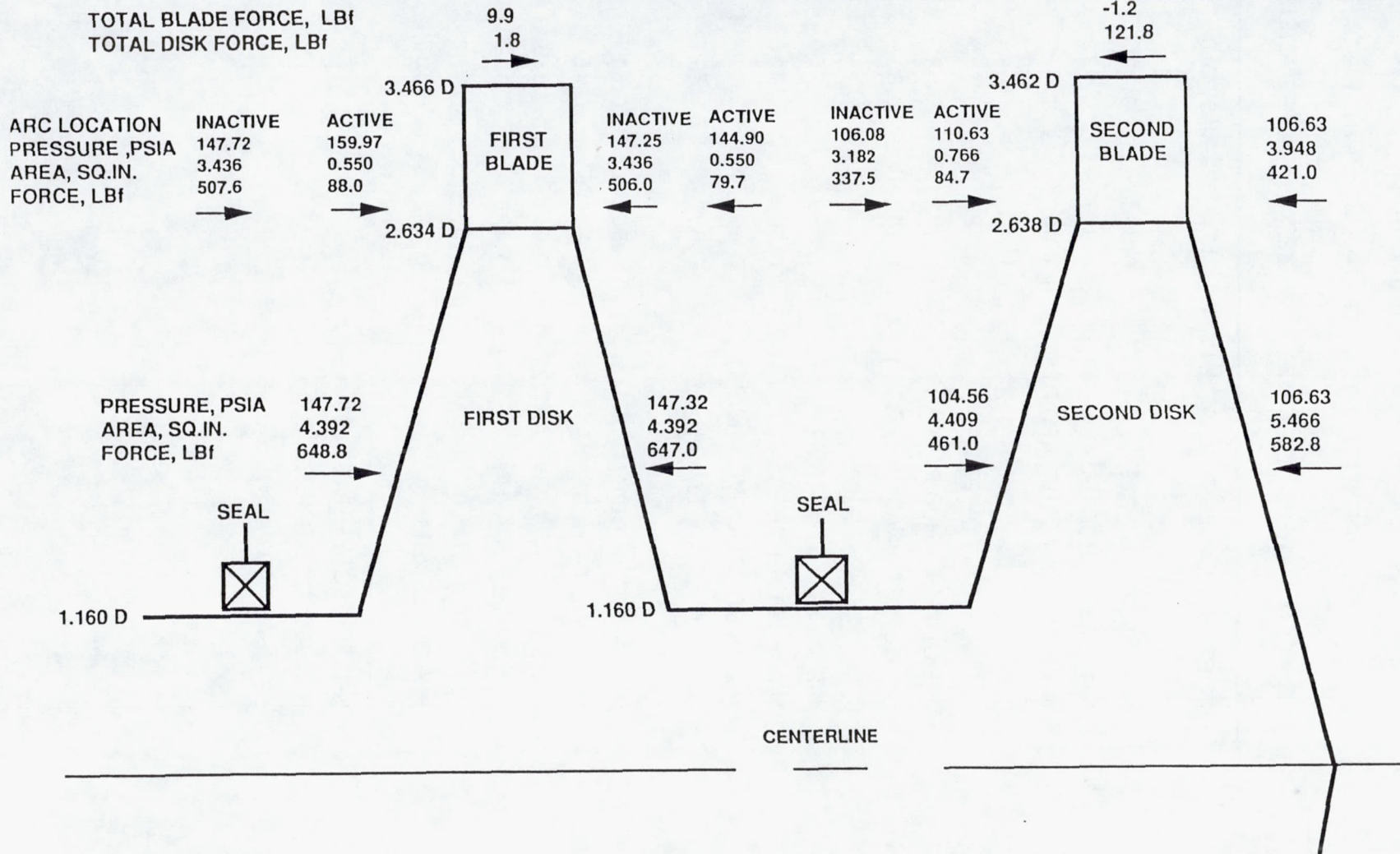
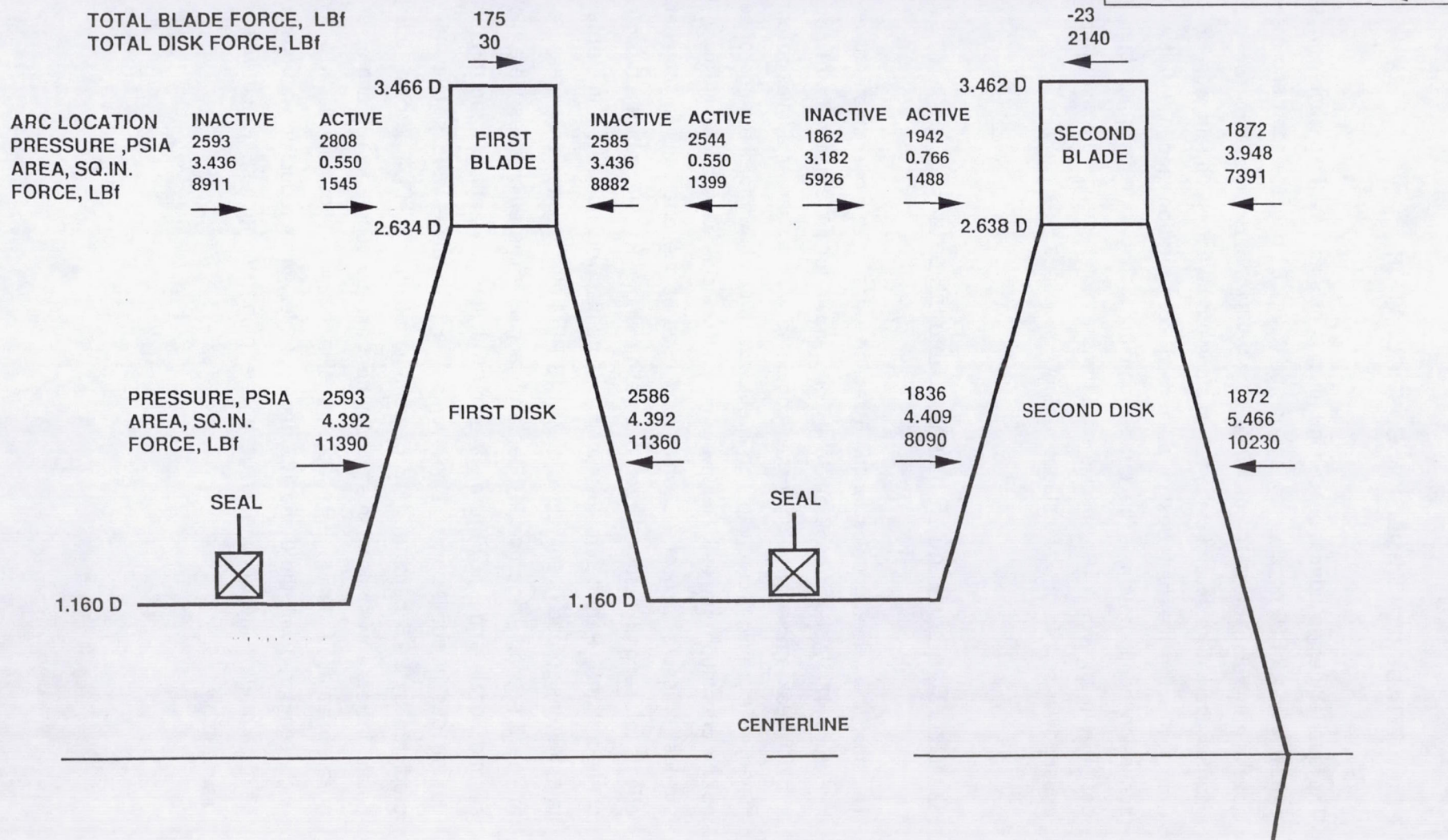

Figure 46 Axial Thrust From Pressure Loads

Half Design Configuration, Design Conditions, 6 Deg Second Nozzle (Test 9, Line 10)

Test Pressures Ratioed To Design Inlet Pressure of 3747 Psia

TOTAL TURBINE FORCE, LBf 1912



- 7 6 -

QUARTER DESIGN ADMISSION CONFIGURATION

The quarter design admission configuration consisted of a first stage admission of 6.9 percent with 2 of 29 nozzles flowing, one per half, 180 degrees apart and a second stage nozzle admission of 12.9 percent with 4 of 31 nozzles flowing, two per half, 180 degrees apart. The second stage to first stage nozzle admission ratio was 1.871 compared with 1.406 for the half design admission configuration and 1.310 for the design admission configuration. The quarter configuration design is applicable to a turbine design with an even lower specific speed and a higher design pressure ratio for a near-equal power split for the two stages for low flow losses.

Quarter Configuration Efficiency Characteristic

The best fit efficiency curves for the 5 second stage nozzle orientation angles are shown in **Figure 47**. A lower peak efficiency was shown for the smaller arc of admission with a lower peak efficiency velocity ratio compared with the larger admission configurations tested. A more significant variation in efficiency was shown for the range of second stage nozzle orientation angles. Relatively high efficiencies were shown in these Figures for the test pressure ratio of 2.0 which was used as the reference for comparison of the effects of second stage nozzle orientation angle for the quarter design admission configuration. Parameters for these test points were tabulated in **Table 11** for the targeted design equivalent speed of 21,219 RPM and an equivalent pressure ratio of 2.0 for the 5 second stage nozzle orientation angles. The efficiencies were plotted versus second nozzle angle in **Figure 48** along with the gas path program prediction for the quarter design admission configuration. The test values were significantly lower than predicted by 26.5 percent, 11.2 percentage points. A 43.4 percent, 9.5 percentage points, increase was shown in efficiency from the -30 degree to +30 degree second stage nozzle orientation angles. A reduction in efficiency was shown for the +10 degree nozzle angle compared with the 0 and +30 degree angles. This reduction was possibly due to a shift of one of the second stage nozzle plugs during test, which was found upon disassembly.

Figure 47
 2 STAGE PARTIAL ADMISSION TURBINE
 EFFICIENCY VS U/CO

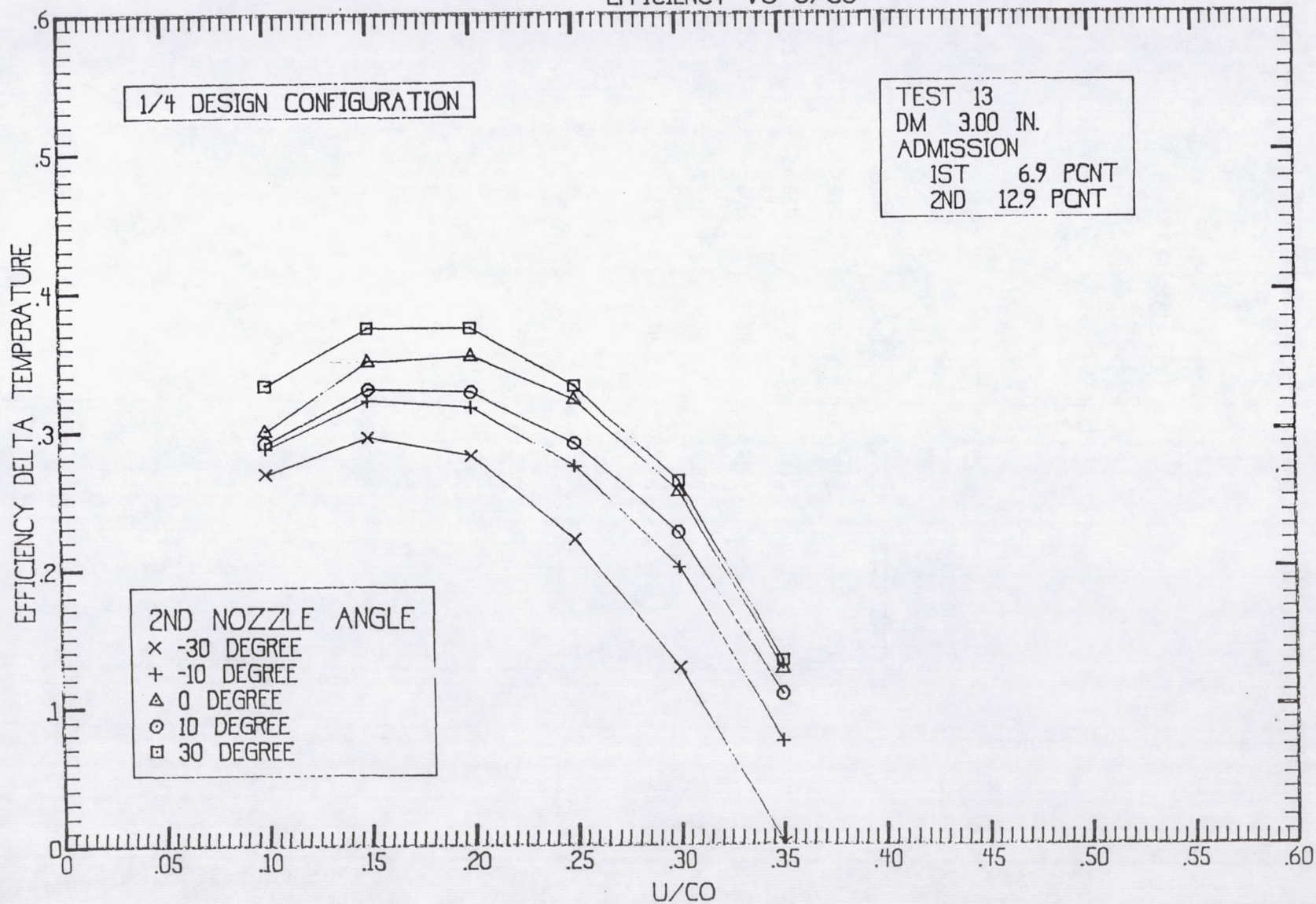
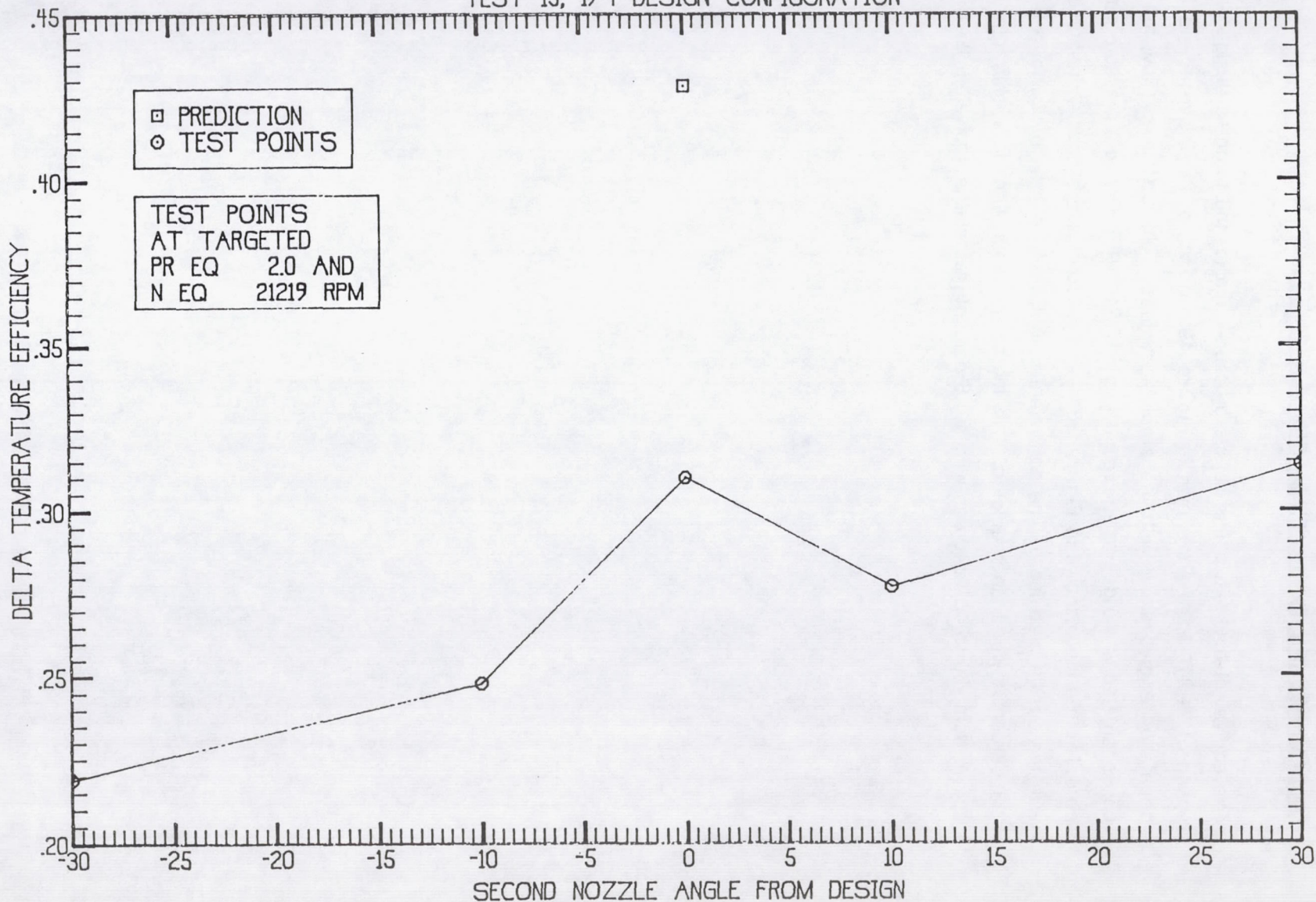

Table 11

TARGET N (eq) AND PR (eq)
 $\frac{1}{4}$ DESIGN ARC OF ADMISSION

2-N ANGLE, DEGREES	LINE NUMBER TEST 13	N (eq) RPM	PR (eq)	FLOW (eq) LB/SEC	EFFICIENCY (ETA)	Um/Co
0	PREDICTED	21219	2.0001	0.01725	0.4218	0.2662
-30	44	20970	1.997	0.0164	0.219	0.255
-10	48	21282	1.979	0.0163	0.248	0.262
0	50	21144	1.992	0.0167	0.310	0.259
+10	56	21256	1.989	0.0163	0.277	0.260
+30	59	21143	1.978	0.0167	0.314	0.261

Figure 48
2 STAGE PARTIAL ADMISSION TURBINE
TEST 13, 1/4 DESIGN CONFIGURATION



Quarter Configuration Flow Characteristic

The equivalent flow test points versus pressure ratio for the targeted design equivalent speed of 21,219 RPM are shown in **Figure 49** for each of the 5 second stage nozzle orientation angles along with the predicted values. The equivalent flow for the test points targeted at the design equivalent speed of 21,219 RPM and a pressure ratio of 2.0 from **Table 11** are shown in **Figure 50** versus second stage nozzle orientation along with the design prediction. The equivalent flow at the 0 degree design orientation was 3.3 percent lower than predicted. An increasing equivalent flow characteristic was shown from -30 to +30 degrees with a 1.8 percent increase in equivalent flow.

Figure 49
 2 STAGE PARTIAL ADMISSION TURBINE
 TEST 13, 1/4 DESIGN CONFIG., DESIGN NEQ

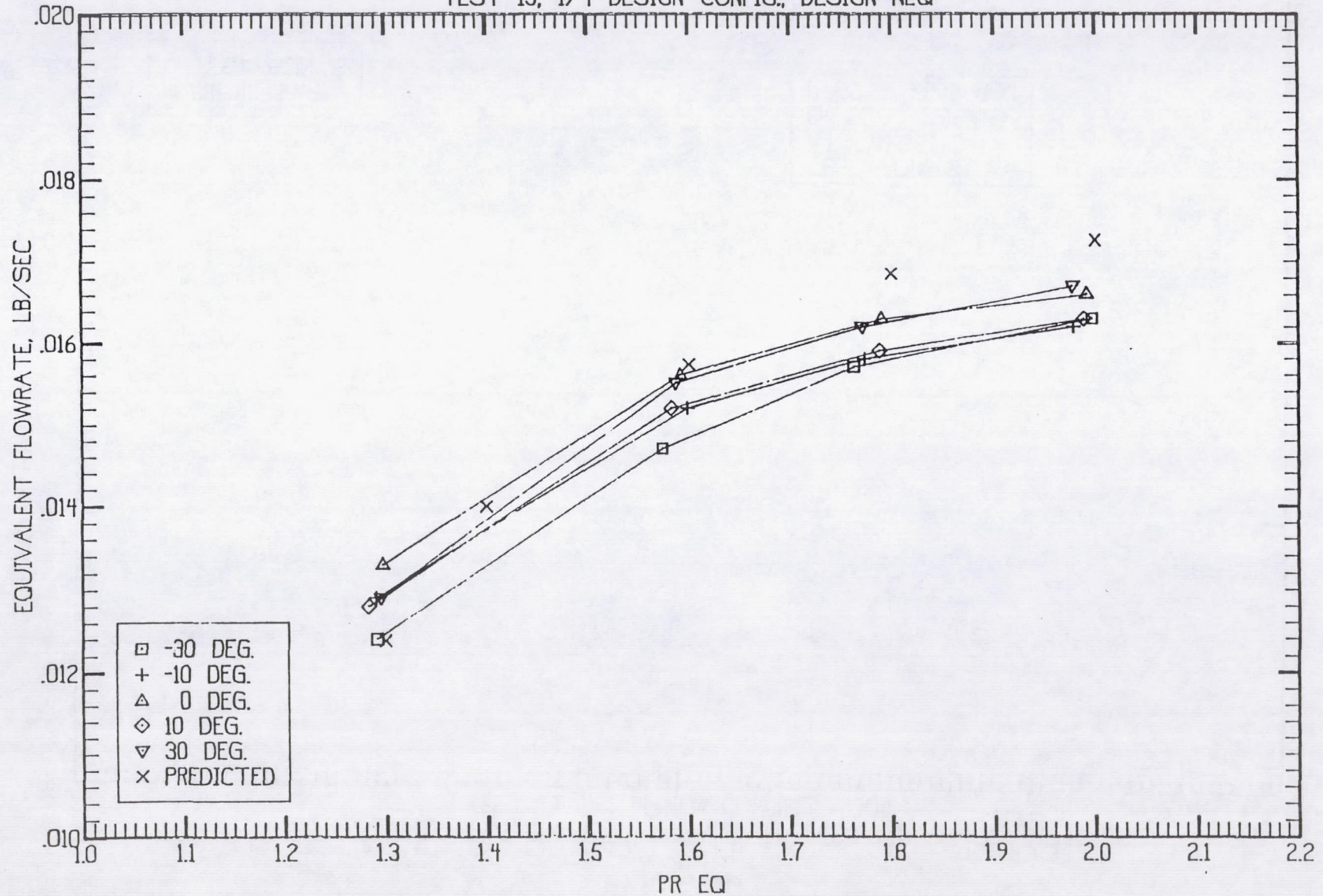
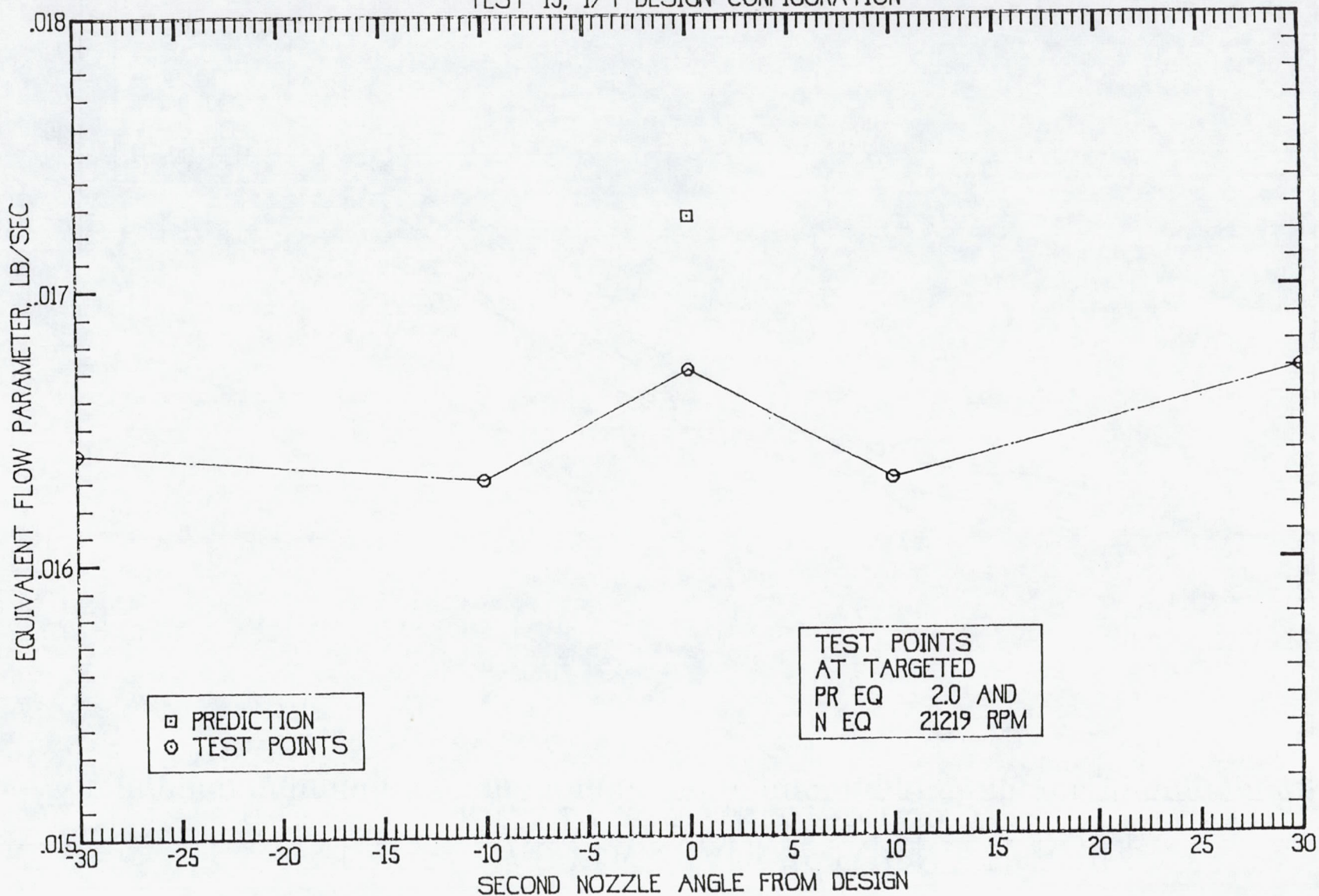

Figure 50

2 STAGE PARTIAL ADMISSION TURBINE

TEST 13, 1/4 DESIGN CONFIGURATION

NASA CR-179548
R/RD 86-214



□ PREDICTION
○ TEST POINTS

TEST POINTS
AT TARGETED
PR EQ 2.0 AND
N EQ 21219 RPM

Quarter Configuration Static Pressure Distribution

The average static pressures measured at each interstage location were averaged and compared with the predictions for the design equivalent test conditions in **Figure 51** and in **Table 12**. Good agreement of the test data with the prediction was shown. The largest deviation was for the first stage nozzle outlet hub pressure with a delta ratio of 0.076, or about 11 percent. The higher first stage pressure ratio was consistent with the higher second-to-first stage nozzle area ratio.

Quarter Configuration Turbine Rotor Axial Thrust

The average active and inactive arc test pressures are shown in **Figure 52**. The areas of active arc pressure were smaller for the half configuration. The areas and forces are also shown in **Figure 52**. The total turbine force was less for the design configuration because of the lower turbine outlet pressure. The pressures were scaled by the design inlet pressure in **Figure 53**. The total turbine force was 2,118 pounds for the high design pressures.

Figure 51

INTERSTAGE STATIC PRESSURE DISTRIBUTION AT QUARTER DESIGN
(TEST 10, LINE 14, AVERAGES OF MEASUREMENTS AT LOCATIONS)

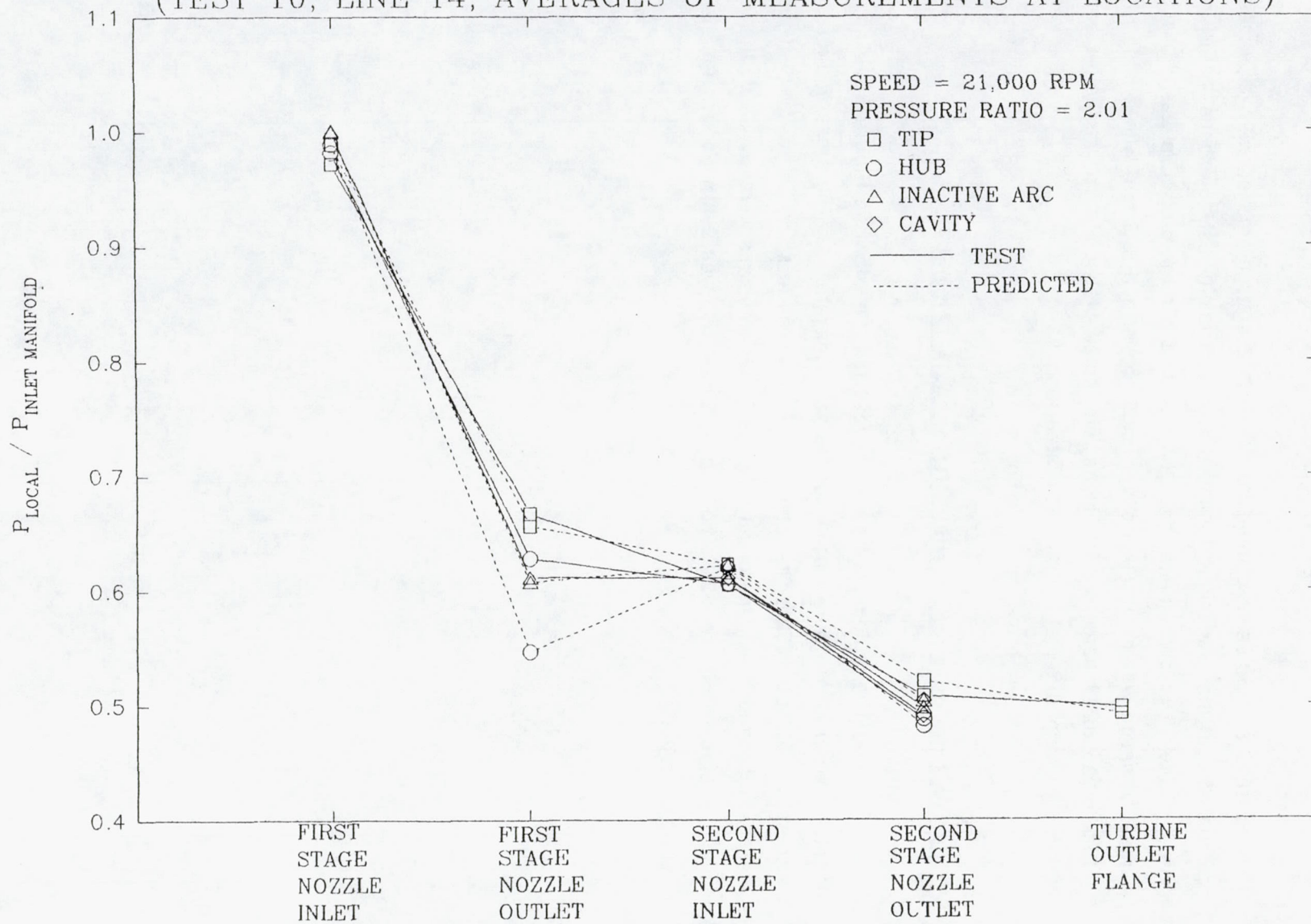

TABLE 12. Interstage Static Pressure Distribution Ratios, Quarter Design Configuration
COMPARISON OF TEST (TEST 10, LINE 14) AND PREDICTION

LOCATION	PRESSURE RATIO	TEST	PREDICTED	DELTA (PRED. - TEST)
INLET TOTAL PRESSURE (PT1), PSIA		215.6	3747.3	- - -
N-1 INLET - TIP/PT1		0.972	0.987	+0.015
N-1 INLET - HUB/PT1		0.982	0.987	+0.005
N-1 INLET - INACTIVE ARC/PT1		1.005	1.000	-0.005
N-1 OUTLET - TIP/PT1		0.667	0.656	-0.011
N-1 OUTLET - HUB/PT1		0.628	0.547	-0.081
N-1 OUTLET - INACTIVE ARC/PT1		0.612	0.608 (1)	-0.004
N-2 INLET - TIP/PT1		0.607	0.623	+0.016
N-2 INLET - HUB/PT1		0.606	0.620	+0.014
N-2 INLET - INACTIVE ARC/PT1		0.611	0.622 (1)	+0.011
N-2 INLET - CAVITY/PT1		0.618	0.622 (1)	+0.004
N-2 OUTLET - TIP/PT1		0.509	0.521	-0.012
N-2 OUTLET - HUB/PT1		0.488	0.482	-0.006
N-2 OUTLET - INACTIVE ARC/PT1		0.498	0.504 (1)	+0.006
N-2 OUTLET - CAVITY/PT1		0.491	0.504 (1)	+0.013
R-2 OUTLET/PT1		0.498	0.492	-0.006

N-1 : FIRST STAGE NOZZLE

N-2 : SECOND STAGE NOZZLE

(1) MEAN GAS PATH PRESSURE

Figure 52

Axial Thrust From Pressure Loads

Quarter Design Configuration, Design Conditions, -4 Deg Second Nozzle (Test 10, Line 14)

Test Pressures for Inlet Pressure of 215.55 Psia

TOTAL TURBINE FORCE, Lbf 122.1

NASA CR-179548
R/R/D 86-214

- 0.6 -

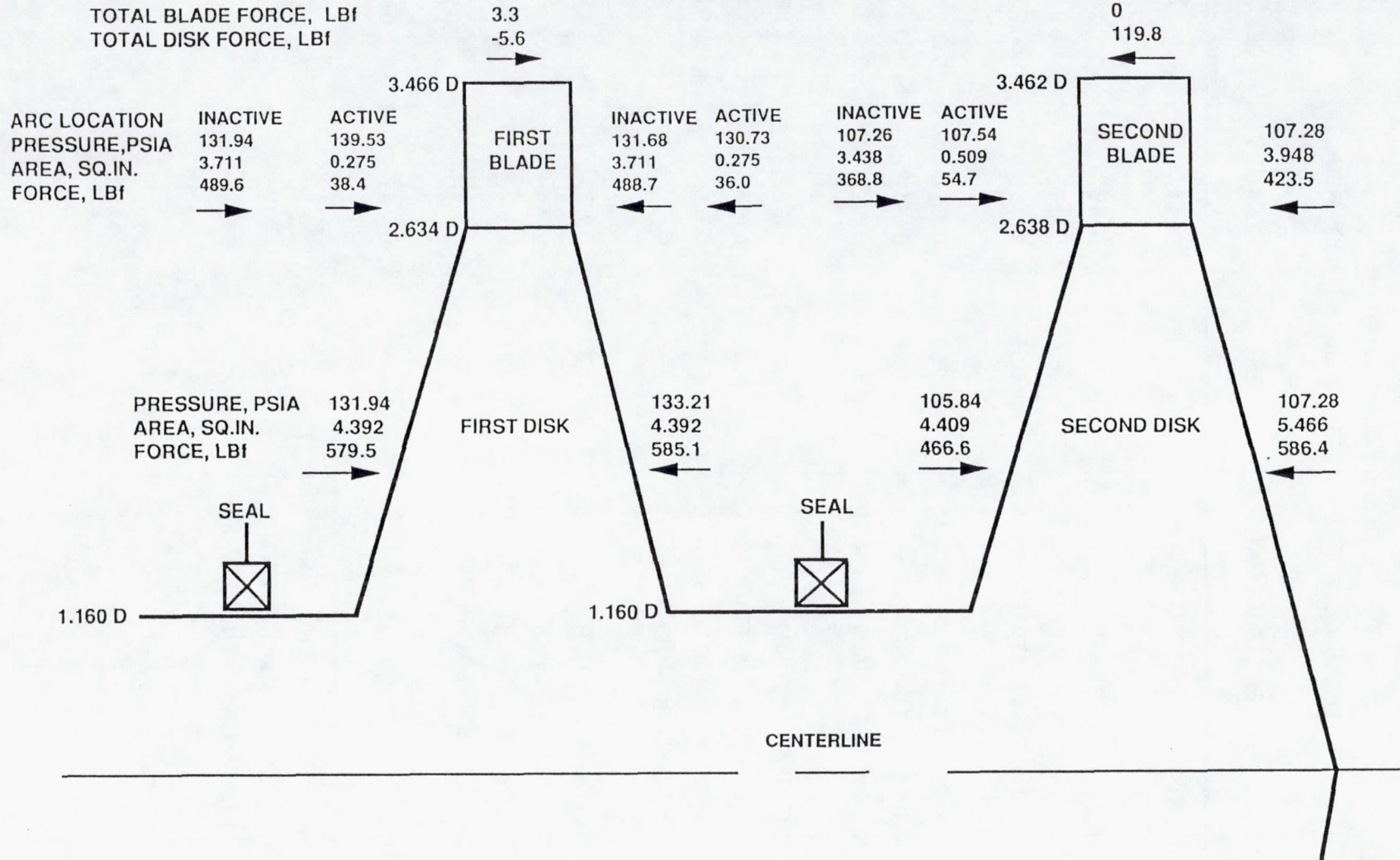
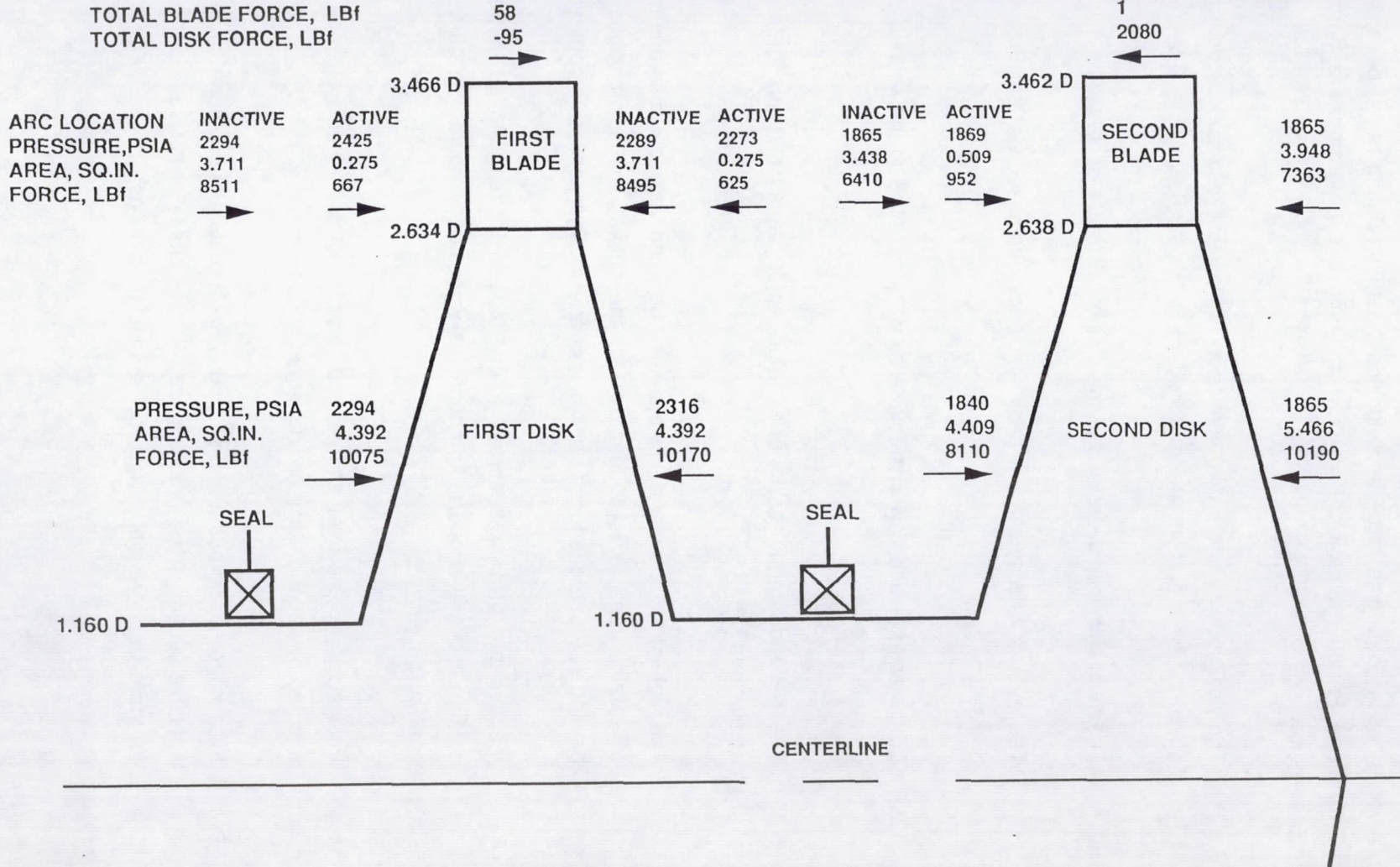

Figure 53 Axial Thrust From Pressure Loads

Quarter Design Configuration, Design Conditions, -4 Deg Second Nozzle (Test 10, Line 14)

Test Pressures Ratioed To Design Inlet Pressure of 3747 Psia

TOTAL TURBINE FORCE, Lbf 2118



-91-

0.2

CONCLUSIONS

A review of the data was made and significant results relating to the performance of the Two Stage Partial Admission Turbine test during this program were determined and listed below.

1. The design two stage partial admission turbine test results exceeded the predicted efficiency by 8 percent and matched the predicted flow within 3 percent.
2. The peak efficiency decreased as the arcs of admission decreased.
3. The overall velocity ratio at peak efficiency decreased as the arcs of admission decreased.
4. Both efficiency and flow characteristics were sensitive to the second stage nozzle orientation angle.
5. The second stage nozzle orientation angle sensitivity was greater at lower admissions.
6. The highest efficiency and flow appeared between second nozzle orientation angles of +10 degrees and +40 degrees for the design admission configuration, and beyond +30 degrees for the half and quarter design admission configurations.
7. Inactive arc pressures across rotor blades (upstream to downstream) for all configurations and operating conditions were nearly equal with partial admission configurations.
8. First stage nozzle inlet and second rotor outlet pressures were not significantly affected by second stage nozzle angular position variation.
9. First stage nozzle outlet and second stage nozzle inlet pressures increased due to effective second stage nozzle inactive arc blockage at the ends of the active arcs for the extreme second stage nozzle angular positions.

10. Only slight changes in interstage pressure distributions were shown for large speed changes with partial admission compared to a full admission reaction turbine.
11. Turbine axial thrust was not significantly affected by second stage nozzle angular position.
12. Partial admission staging provided the lowest turbine axial thrust across the blades and disks of any staging option.

REFERENCES

1. Anon: Orbit Transfer Vehicle Advanced Expander Cycle Engine Point Design Study (Volume II: Study Results). Report No. RI/RD80-218-2, Contract NAS8-33568, Rocketdyne, December 1980.
2. Nusbaum, William J., and Wong, Robert Y., Effect of Stage Spacing on Performance of 3.75-Inch-Mean-Diameter Two-Stage Turbine Having Partial Admission in the First Stage. NASA TN D-2335, 1964.
3. Holeski, D. E., and Stewart, W. L., Study of NASA and NACA Single-Stage Axial Flow Turbine Performance as Related to Reynolds Number and Geometry. J. Eng. Power, Vol. 86, No. 3, July 1964, pp. 296-298.
4. NASA TN D-4700, Cold-Air Investigation of Effects of Partial Admission on Performance of 3.75-Inch Mean-Diameter Single-Stage Axial-Flow Turbine, Hugh A. Klassen, NASA/LeRC, Cleveland, OH, Aug. 1968.

APPENDIX A Standard Air Equivalent Conditions

Standard Air Conditions

Pressure	=	14.696 PSIA
Temperature	=	518.7 °R
Gas Constant	=	53.345 FT LB _f /LB _m °R
Ratio of Specific Heats	=	1.4
Critical Velocity	=	1019.5 FT/SEC

Standard Air Constants

$$\theta_{CR} = \frac{2\gamma g R T_1 Z_1}{\gamma + 1} / (1019.5)^2, \text{ critical velocity ratio based on inlet total temp., test-to-standard air, squared.}$$

$$\delta = P_1 / 14.696, \text{ inlet pressure ratio, test-to-standard air}$$

$$\epsilon = \frac{0.739594}{\gamma} \left(\frac{\gamma + 1}{2}\right)^{\frac{\gamma}{\gamma - 1}}, \text{ gamma function ratio, test-to-standard air}$$

Where:

- γ - Ratio of Specific Heats - Test Gas
- R - Gas Constant - Test Gas
- T_1 - Inlet Total Temp. - Test Gas
- Z_1 - Inlet Compressibility - Test Gas
- P_1 - Inlet Total Pressure - Test Gas
- g - 32.174 FT/SEC²

Standard Air Equivalent Parameters

$$W_{EQ} = \frac{W \sqrt{\theta CR} \epsilon}{\delta}$$

$$N_{EQ} = \frac{N}{\sqrt{\theta CR}}$$

$$PR_{EQ} = \left(\frac{1}{1 - 0.1666667 \left(\frac{\gamma + 1}{\gamma - 1} \right) \left[1 - \frac{1}{(PR) \frac{\gamma - 1}{\gamma}} \right]} \right)^{3.5}$$

Where:

W - Test Flow Rate - Pounds/Second

N - Test Speed - RPM

PR - Test Pressure Ratio

APPENDIX B Raw Data, Tests 8-10 (Pressure Distribution)

This appendix consists of three test data sets for the following three configurations:

<u>Test Number</u>	<u>Configuration</u>
8	Design
9	Half Design
10	Quarter Design

The data was not reduced because two thermocouples measuring the turbine inlet temperature and the flow nozzle inlet temperature were faulty during testing. The channel numbers associated with these measurements were 3 and 4.

The data set represents the pressure distribution between stages, both radially (hub and tip) and circumferentially. Channel numbers correspond to pressure tap locations shown in **Figure 2 2**. Note that the pressure magnitudes are gage pressures.

constant parameters			constant parameters				constant parameters			constant parameters	
a	b	c	d	e	f	g	h	i	j	k	l
specific heat ratio	gas R (nitrogen) lbf-ft/lbm-f	atm pr psia	flow nozzle inlet dia (inch)	flow nozzle throat dia (inch)	turbine mean dia (inch)	mach no due to area ratio	tot to sta pressure ratio due to area ratio	critical flow parameter gamma	area of flow noz throat (in.sq.)	1st stage nozzle flow area (in.sq.)	2nd stage nozzle flow area (in.sq.)
=====	=====	=====	=====	=====	=====	=====	=====	=====	=====	=====	=====
1.4040	55.1644	14.2180	0.8700	0.4000	3.0000	0.1234	1.0107	0.8121	0.1257	2.6851	3.2924
turbine seal leakage lbm/sec											
=====											
0.022											

channel number	1	2	3	4	5	6	7	21	22	23	25
slice number	speed rpm	shaft torque in-lbf	new sonic nozzle temp deg f	inlet manifold temperature deg F	exhaust manifold temp deg f	nozzle position degree	old sonic nozzle temp deg f	sonic noz u/s press psig	sonic noz thrt press psig	inlet manifold avg press psig	1st stg noz inl press hub # 4 psig
1	17.3	-0.120	68.400	71.910	73.160	0	70.760	0.000	0.000	0.000	0.070
2	35005.0	340.400	68.440	71.910	71.570	0	70.720	12.880	13.060	13.350	13.370
3	1740.2	-0.280	68.680	71.910	76.950	0	71.270	204.320	204.920	204.450	203.850
4	21055.3	45.790	59.490	67.570	-39.700	0	18.490	372.950	211.450	199.580	197.290
5	21072.6	45.660	59.360	65.920	-36.170	5	20.080	374.280	211.540	199.640	197.730
6	21072.6	45.880	59.420	65.240	-35.260	10	20.460	373.080	210.640	198.690	197.120
7	21102.9	45.820	59.930	64.730	-34.560	20	20.780	372.650	209.870	198.050	196.700
8	21098.5	45.210	60.110	64.260	-33.790	30	21.540	372.600	210.220	198.310	196.840
9	21096.4	43.960	59.910	64.060	-32.140	40	22.300	371.730	210.370	198.590	197.080
10	21085.6	44.620	59.880	63.470	-32.050	0	23.490	371.870	210.260	198.430	196.770
11	21092.1	43.890	60.160	63.290	-31.200	-5	24.490	371.880	210.670	198.870	197.000
12	21107.2	43.170	59.960	63.060	-30.370	-10	25.030	371.730	211.130	199.440	197.410
13	21120.2	41.910	60.250	62.730	-28.900	-20	25.730	371.470	212.450	200.790	198.540
14	21100.7	40.270	60.370	62.670	-26.970	-30	26.250	371.740	214.120	202.560	200.250
15	21100.7	51.340	60.070	62.200	-34.390	-30	27.940	383.920	213.590	201.250	199.060
16	21111.5	53.630	60.330	61.830	-35.830	-10	28.380	384.290	211.450	198.880	197.360
17	21107.2	55.090	60.030	61.780	-36.430	0	28.500	383.930	209.880	197.200	196.100
18	21105.0	60.180	60.090	61.530	-38.650	10	29.560	392.470	212.110	199.050	197.390
19	21105.0	59.400	59.510	61.500	-37.270	40	30.320	392.490	212.390	199.410	197.530
20	21096.4	33.810	60.550	61.600	-16.140	40	31.840	359.480	211.830	200.830	198.820
21	21092.1	35.570	60.020	61.550	-16.650	10	32.220	358.910	210.880	199.970	198.680
22	21087.7	34.940	60.160	61.730	-16.070	0	32.450	358.860	211.580	200.680	198.910
23	21094.2	33.720	60.490	61.570	-15.290	-10	32.940	358.860	212.530	201.790	199.600
24	21089.9	30.850	60.810	61.570	-11.910	-30	33.710	352.560	211.990	201.540	199.430
25	21057.5	7.600	61.650	61.990	9.710	-30	31.680	280.320	205.920	198.940	198.290
26	21061.8	9.090	61.650	62.380	9.200	-10	31.910	280.210	204.970	198.070	197.490
27	21055.3	8.770	61.940	62.360	9.070	0	31.910	279.930	204.380	197.440	196.940
28	21055.3	9.310	61.990	62.500	9.250	10	31.790	280.050	204.070	197.130	196.690
29	21061.8	8.320	61.760	62.820	10.910	40	31.930	279.840	205.090	198.160	197.030
30	15088.9	21.370	62.090	62.390	6.150	40	34.710	295.950	206.640	199.040	198.010
31	15119.2	21.300	62.080	62.040	5.950	10	34.740	296.090	206.640	198.940	198.000
32	15117.0	20.790	61.900	61.920	6.170	0	34.780	295.730	207.030	199.400	198.180
33	15108.4	20.350	62.220	61.920	6.810	-10	34.510	295.730	207.860	200.270	198.780
34	15143.0	18.640	62.710	61.830	8.380	-30	34.580	295.490	209.980	202.500	200.790
35	15168.9	44.400	62.020	61.530	-6.080	-30	36.100	358.210	212.090	201.220	199.980
36	15181.9	46.450	61.920	61.250	-7.080	-10	36.370	358.010	209.270	198.310	197.330
37	15177.6	47.580	61.760	61.550	-7.520	0	36.860	358.230	208.110	197.070	196.140
38	15177.6	49.610	61.760	61.040	-7.760	10	37.120	366.220	212.060	200.720	199.300
39	15155.9	48.880	61.900	60.990	-7.580	40	38.000	360.720	209.070	197.990	196.820
40	15192.7	63.080	62.130	60.860	-15.080	40	38.370	382.960	210.740	198.420	196.850
41	15034.9	64.040	61.830	60.720	-14.690	10	38.640	388.330	213.250	200.620	198.440

66

Two Stage Partial Admission Turbine Test (NAS3-23773) Test No 8 : DESIGN CONFIGURATION TEST DATE 12,13DEC 1985

channel number	1	2	3	4	5	6	7	21	22	23	25
slice number	speed rpm	shaft torque in-lbf	new sonic nozzle temp deg f	inlet manifold temperature deg F	exhaust manifold temp deg f	nozzle position degree	old sonic nozzle temp deg f	sonic noz u/s press psig	sonic noz thrt press psig	inlet manifold avg press psig	1st stg noz inl press hub # 4 psig
42	15041.4	64.210	61.620	61.060	-14.800	0	39.110	388.440	213.450	200.770	198.570
43	15050.0	62.840	61.920	61.000	-14.120	-10	39.210	389.110	214.970	202.290	200.030
44	15065.1	54.930	61.880	60.620	-10.910	-30	39.140	372.710	210.430	198.610	197.390
45	15063.0	65.870	62.020	60.700	-16.590	-30	39.230	385.750	211.590	199.070	197.230
46	15086.8	69.060	61.580	60.850	-18.340	-10	39.430	385.250	208.270	195.570	194.270
47	15101.9	75.410	61.530	60.780	-20.800	0	39.730	396.150	211.610	198.400	196.500
48	15101.9	76.540	61.720	60.620	-21.230	10	39.980	396.290	210.490	197.140	195.530
49	15127.8	76.920	61.760	60.440	-21.230	40	40.480	396.190	210.340	197.010	195.030
50	25009.1	49.820	61.110	61.710	-25.900	40	41.160	389.360	212.690	200.080	197.910
51	25009.1	51.900	61.460	61.740	-27.470	10	40.930	389.310	211.950	199.230	197.350
52	25007.0	50.090	61.780	61.920	-26.990	0	41.020	389.280	212.990	200.270	198.000
53	25013.5	49.150	60.860	62.100	-26.400	-10	41.120	389.360	214.000	201.340	198.960
54	24983.2	43.870	60.920	62.010	-20.670	-31	41.190	376.940	212.570	200.660	198.400
55	24996.2	31.920	61.410	62.430	-9.460	-31	41.260	360.270	211.450	200.520	198.980
56	25009.1	34.740	62.020	62.660	-12.540	-10	41.670	359.800	207.710	196.560	195.570
57	25002.6	37.200	61.760	62.900	-13.730	0	41.870	369.160	211.420	199.840	197.800
58	25015.6	38.750	61.810	62.990	-14.670	10	41.910	369.250	209.960	198.380	197.030
59	24929.1	32.720	61.530	62.830	-8.650	40	41.480	362.060	210.330	199.190	197.290
60	24955.1	22.870	60.650	63.040	-6.140	40	36.710	343.820	210.500	200.610	198.690
61	25426.3	23.930	59.840	62.760	-16.310	10	31.700	345.230	209.680	199.500	197.810
62	24914.0	25.150	58.850	62.110	-21.290	0	27.640	345.600	209.990	199.870	198.020
63	25054.5	24.600	59.420	61.580	-22.490	-10	24.270	346.170	210.740	200.580	198.750
64	24937.8	24.000	59.680	60.860	-19.140	-30	23.040	343.620	210.460	200.480	199.120
65	24965.9	3.590	61.710	60.900	12.860	-30	26.290	276.020	207.490	200.900	200.270
66	24989.7	5.080	62.150	61.940	17.130	-10	32.220	281.690	208.910	202.120	200.670
67	25056.7	5.130	62.990	62.270	18.210	0	33.020	281.600	208.670	201.850	200.730
68	25458.8	4.570	62.450	62.780	19.440	10	34.140	278.270	206.170	199.380	198.570
69	25121.5	4.090	62.500	62.960	20.980	40	34.960	277.080	206.900	200.150	198.760
70	10093.1	28.650	62.690	61.510	14.420	40	38.820	291.220	205.720	198.360	197.070
71	10134.2	30.660	62.620	61.990	13.350	10	39.230	301.530	207.630	199.770	198.830
72	10119.1	30.550	62.730	62.060	13.480	0	39.250	301.450	207.740	199.940	198.830
73	10149.4	29.910	62.690	61.970	13.790	-10	39.320	301.350	207.830	200.050	198.840
74	10123.4	28.550	62.570	61.690	14.750	-30	39.370	301.480	210.650	202.870	200.930
75	10104.0	55.880	62.010	60.580	3.680	-30	39.520	356.810	209.430	198.610	196.850
76	10101.8	56.540	62.080	60.810	3.610	-10	39.980	356.760	208.020	197.140	195.940
77	10084.5	60.040	62.690	60.930	2.780	0	40.120	363.610	209.780	198.510	197.220
78	10097.5	60.530	61.970	60.260	2.760	10	40.440	363.830	209.310	197.890	196.730
79	10084.5	61.150	62.110	60.620	2.670	40	40.800	367.140	211.530	200.100	198.170
80	10114.8	73.420	61.740	60.120	-1.840	40	41.410	383.400	212.340	199.940	198.220
81	10088.8	73.390	61.940	59.860	-2.070	10	41.260	383.440	211.670	199.260	197.780
82	10052.1	72.950	61.810	59.820	-1.720	0	41.530	383.240	212.170	199.830	197.960

- 100 -

channel number	1	2	3 new sonic nozzle	4 inlet manifold temperature deg F	5 exhaust manifold temp deg f	6 nozzle position degree	7 old sonic nozzle temp deg f	21 sonic noz u/s press psig	22 sonic noz thrt press psig	23 inlet manifold avg press psig	25 1st stg noz inl press hub # 4 psig
slice number	speed rpm	shaft torque in-lbf	temp deg f	temperature deg F	temp deg f	degree	temp deg f	press psig	press psig	psig	psig
=====	=====	=====	=====	=====	=====	=====	=====	=====	=====	=====	=====
83	10091.0	71.940	62.340	59.900	-1.530	-10	41.660	383.310	212.710	200.330	198.420
84	10091.0	67.880	61.970	60.070	-0.360	-30	41.320	376.130	211.120	199.190	197.620
85	10045.6	66.510	62.410	59.750	0.160	-30	41.440	374.830	211.380	199.490	197.930
86	10073.7	79.520	61.740	59.930	-4.810	-30	41.590	387.090	211.700	199.080	197.500
87	10093.1	80.950	61.740	59.490	-6.340	-10	41.760	386.680	209.650	197.050	195.630
88	10088.8	83.350	61.740	59.370	-6.410	0	42.170	393.150	212.500	199.510	197.290
89	10088.8	85.780	61.950	59.600	-7.210	10	41.980	392.430	210.510	197.350	196.110
90	10099.6	84.980	61.670	59.310	-6.400	40	42.230	392.560	211.250	198.210	196.280
91	765.3	118.950	62.220	58.610	27.850	40	42.620	406.070	214.360	200.580	198.360
92	823.6	116.640	62.410	58.770	27.800	10	42.800	406.160	213.740	199.930	198.010
93	748.0	115.280	62.250	58.590	27.920	0	42.490	405.640	214.260	200.460	198.180
94	620.4	112.410	62.060	58.260	28.030	-10	42.990	401.130	213.060	199.550	197.260
95	724.2	104.790	62.320	58.130	28.550	-31	42.980	395.280	212.870	199.720	197.370
96	693.9	91.530	62.680	57.740	29.540	-31	42.620	381.990	210.530	198.120	196.070
97	853.9	97.570	62.600	57.730	29.580	-10	43.010	388.190	211.970	199.160	197.140
98	709.0	101.980	62.590	57.730	29.090	0	43.150	393.220	212.080	198.990	197.220
99	693.9	101.440	62.590	57.520	29.040	0	43.100	393.800	212.840	199.750	198.040
100	763.1	102.440	62.870	57.550	29.330	10	43.370	394.170	211.640	198.530	197.030
101	752.3	104.530	62.710	57.430	30.030	40	43.400	394.490	212.360	199.100	197.190
102	544.8	95.020	63.040	57.500	30.670	40	43.380	386.760	213.630	201.100	199.420
103	650.7	90.170	62.710	57.300	31.050	10	42.890	382.290	211.890	199.570	197.910
104	626.9	88.960	62.660	57.450	31.230	0	42.900	381.860	212.270	199.970	197.980
105	680.9	88.390	62.680	57.270	31.120	-10	43.210	381.540	213.290	201.080	198.930
106	795.5	82.220	62.730	57.230	31.480	-30	42.990	377.670	214.270	202.390	200.540
107	765.3	47.960	62.830	57.290	33.890	-30	42.030	311.570	208.280	199.900	198.170
108	732.8	50.180	62.830	57.360	33.720	-10	42.330	311.540	206.640	198.180	197.520
109	802.0	52.390	62.920	57.430	33.510	0	42.480	317.300	207.840	199.160	197.530
110	817.1	52.800	62.940	57.410	33.540	10	42.780	317.040	207.130	198.380	197.380
111	657.2	54.040	63.080	57.450	33.600	40	42.600	317.720	207.520	198.760	197.400
112	4.3	-3.880	64.490	57.300	35.500	0	46.600	-0.080	0.000	0.490	1.300
113	0.0	-3.680	64.910	58.030	42.480	0	47.380	200.120	200.920	200.790	200.320
114	0.0	-3.670	65.350	58.150	34.150	0	49.210	-0.160	0.000	0.470	1.330
115	34875.3	336.720	65.560	57.870	39.160	0	49.050	-0.160	0.060	0.470	1.160

- 101 -

channel number	26 1st stg noz inl press hub # 3 psig	27 1st stg noz inl press hub # 2 psig	29 1st stg noz inl press hub # 6 psig	31 1st stg noz inl press tip # 4 psig	32 1st stg noz inl press tip # 3 psig	33 1st stg noz inl press tip # 2 psig	36 1st stg noz inl noz # 1 psig	37 1st stg noz inl noz # 2 psig	39 1st stg noz exit press hub # 4 psig	40 1st stg noz exit press hub # 3 psig	41 1st stg noz exit press hub # 2 psig
1	-0.010	0.000	0.000	0.000	0.000	-0.030	0.000	0.000	0.000	0.000	0.000
2	12.920	13.340	13.030	12.740	12.370	12.870	12.850	13.570	12.880	13.060	13.120
3	204.200	204.720	204.870	203.450	204.040	203.140	203.480	205.330	203.500	204.210	205.210
4	197.260	197.400	197.080	194.530	195.050	194.380	198.550	202.600	143.050	151.190	152.750
5	197.310	197.470	197.150	194.500	195.100	194.460	198.590	202.600	143.110	151.010	152.470
6	196.350	196.540	196.260	193.680	194.170	193.550	197.690	201.740	142.670	150.300	151.350
7	195.670	195.780	195.520	193.000	193.420	192.770	196.970	201.060	142.510	149.730	150.040
8	196.040	196.090	195.900	193.280	193.780	193.030	197.280	201.440	142.970	150.230	149.850
9	196.260	196.370	196.120	193.550	194.020	193.320	197.570	201.770	143.240	150.750	150.080
10	196.060	196.150	195.880	193.290	193.830	193.190	197.370	201.610	141.960	149.950	151.420
11	196.500	196.630	196.370	193.700	194.230	193.670	197.810	202.050	142.250	150.750	152.400
12	197.060	197.160	196.860	194.300	194.810	194.230	198.340	202.550	142.570	151.650	153.310
13	198.490	198.580	198.320	195.670	196.350	195.610	199.640	203.940	143.480	154.480	155.620
14	200.340	200.350	200.220	197.490	198.140	197.470	201.420	205.680	144.780	157.710	157.730
15	198.810	198.880	198.710	195.870	196.470	195.810	200.090	204.580	138.120	152.180	151.560
16	196.360	196.450	196.070	193.370	193.980	193.390	197.730	202.290	136.290	147.050	148.180
17	194.690	194.820	194.500	191.850	192.400	191.730	196.190	200.810	135.100	144.330	145.700
18	196.320	196.260	196.020	193.330	193.780	193.160	197.820	202.540	134.850	143.460	144.240
19	196.700	196.700	196.570	193.860	194.300	193.530	198.280	202.980	136.470	144.270	143.040
20	198.560	198.620	198.590	196.040	196.450	195.730	199.740	204.160	150.390	157.750	157.200
21	197.630	197.700	197.610	195.030	195.470	194.870	198.800	203.240	149.450	156.640	157.110
22	198.370	198.420	198.310	195.740	196.160	195.610	199.460	203.960	149.640	157.300	158.510
23	199.430	199.510	199.410	196.780	197.310	196.730	200.520	205.020	150.270	158.760	160.380
24	199.290	199.410	199.420	196.690	197.330	196.640	200.310	204.770	149.930	161.790	162.240
25	197.350	197.550	197.650	195.290	195.930	195.350	197.760	201.720	166.170	174.280	175.560
26	196.330	196.550	196.610	194.390	194.840	194.310	196.770	200.760	166.550	172.330	174.080
27	195.780	195.920	196.030	193.810	194.260	193.680	196.210	200.180	166.520	171.890	172.930
28	195.460	195.540	195.700	193.490	193.900	193.280	195.870	199.850	166.450	171.610	172.460
29	196.540	196.590	196.820	194.590	194.970	194.320	196.870	200.890	167.460	172.740	173.030
30	197.270	197.360	197.510	195.220	195.620	194.940	197.780	201.930	167.030	171.050	171.140
31	197.140	197.240	197.330	195.100	195.540	194.920	197.680	201.890	166.660	170.920	171.790
32	197.610	197.690	197.780	195.520	195.980	195.330	198.150	202.270	166.830	171.310	172.560
33	198.500	198.660	198.710	196.420	196.920	196.310	199.020	203.160	167.440	172.540	173.960
34	200.810	200.900	201.080	198.680	199.300	198.600	201.270	205.380	168.800	176.170	176.850
35	198.970	199.000	199.060	196.330	196.910	196.180	200.060	204.650	150.020	160.740	160.220
36	195.990	196.000	195.930	193.250	193.800	193.250	197.130	201.780	147.580	155.600	156.520
37	194.690	194.700	194.640	192.000	192.420	191.910	195.850	200.530	146.870	153.140	154.440
38	198.260	198.320	198.230	195.570	196.020	195.420	199.540	204.270	149.960	155.330	156.220
39	195.490	195.400	195.530	192.890	193.250	192.600	196.700	201.390	148.840	153.650	152.820
40	195.610	195.530	195.520	192.810	193.200	192.540	197.120	202.050	141.910	146.690	145.490
41	197.840	197.790	197.770	194.930	195.330	194.790	199.350	204.240	142.390	147.800	148.170

- 102 -

NASA CR-179548
RI/RD 86-214

channel number	26 1st stg noz inl press hub # 3 psig	27 1st stg noz inl press hub # 2 psig	29 1st stg noz inl press hub # 6 psig	31 1st stg noz inl press tip # 4 psig	32 1st stg noz inl press tip # 3 psig	33 1st stg noz inl press tip # 2 psig	36 1st stg noz inl noz # 1 psig	37 1st stg noz inl noz # 2 psig	39 1st stg noz exit press hub # 4 psig	40 1st stg noz exit press hub # 3 psig	41 1st stg noz exit press hub # 2 psig
42	198.090	197.990	197.910	195.000	195.440	194.960	199.450	204.350	141.810	147.880	149.160
43	199.780	199.650	199.610	196.810	197.190	196.640	201.080	205.870	142.540	150.780	151.870
44	196.170	196.140	196.170	193.350	193.900	193.280	197.400	202.170	141.520	153.210	152.470
45	196.380	196.320	196.340	193.460	193.970	193.350	197.720	202.620	136.630	149.310	148.350
46	192.840	192.750	192.720	189.930	190.390	189.800	194.310	199.270	133.130	143.030	143.240
47	195.460	195.400	195.300	192.320	192.730	192.310	196.970	201.990	133.780	141.350	143.050
48	194.340	194.190	194.100	191.220	191.530	191.100	195.850	200.880	133.460	138.990	140.010
49	194.160	193.940	194.030	191.130	191.410	190.870	195.720	200.810	134.720	139.280	137.850
50	197.210	197.180	197.290	194.360	194.720	194.070	198.690	203.780	136.810	146.470	145.230
51	196.340	196.200	196.280	193.400	193.710	193.210	197.810	202.850	135.940	145.210	145.250
52	197.460	197.390	197.490	194.550	194.980	194.430	198.950	203.970	136.520	146.690	147.470
53	198.560	198.560	198.630	195.650	196.110	195.570	200.070	205.050	137.090	148.180	149.380
54	198.180	198.070	198.150	195.270	195.830	195.150	199.330	204.210	137.900	153.600	153.230
55	198.140	198.080	198.250	195.350	195.930	195.390	199.200	203.970	143.920	158.280	158.450
56	194.070	194.130	194.130	191.310	191.850	191.370	195.310	200.250	141.240	151.470	152.950
57	197.310	197.270	197.380	194.520	194.960	194.460	198.560	203.570	143.430	152.850	154.070
58	195.800	195.680	195.810	192.980	193.370	192.880	197.050	202.010	141.980	150.860	151.400
59	196.820	196.670	196.740	194.280	194.660	193.890	197.930	202.890	146.230	155.900	154.030
60	198.290	198.170	198.320	195.970	196.270	195.570	199.200	203.980	153.800	162.670	160.900
61	197.310	197.150	197.310	194.830	195.200	194.490	198.230	203.020	151.350	160.220	159.030
62	197.600	197.470	197.630	195.130	195.440	194.790	198.520	203.270	151.700	160.040	159.480
63	198.270	198.210	198.420	195.810	196.150	195.580	199.290	204.000	152.020	160.560	160.500
64	198.220	198.040	198.450	195.600	195.970	195.410	199.180	203.850	150.960	160.330	160.330
65	199.120	199.170	199.600	197.150	197.620	197.080	199.630	203.800	169.460	175.820	176.470
66	200.350	200.420	200.700	198.400	198.810	198.240	200.790	205.090	170.640	176.390	177.280
67	200.140	200.140	200.510	198.260	198.610	197.970	200.580	204.870	170.890	176.430	176.610
68	197.650	197.720	198.020	195.810	196.230	195.580	198.160	202.410	168.980	174.530	174.340
69	198.540	198.550	198.860	196.650	197.010	196.380	198.820	203.070	170.710	176.150	175.950
70	196.500	196.480	196.770	194.710	194.920	194.230	197.060	201.310	168.730	171.900	171.130
71	197.890	197.930	198.120	195.890	196.150	195.520	198.490	202.840	168.050	171.390	170.700
72	197.970	197.990	198.240	195.990	196.320	195.670	198.610	202.960	168.000	171.450	171.210
73	198.150	198.140	198.410	196.120	196.470	195.730	198.710	203.080	167.790	171.790	171.030
74	200.940	200.970	201.400	198.850	199.180	198.610	201.540	205.850	169.990	173.400	174.070
75	196.030	195.980	196.420	193.500	193.660	193.190	197.310	202.100	149.530	152.910	153.760
76	194.750	194.430	194.720	192.010	192.390	191.670	195.810	200.600	148.870	154.330	151.310
77	196.040	195.900	196.080	193.480	193.840	193.150	197.320	202.150	149.210	154.350	152.520
78	195.360	195.300	195.420	192.860	193.150	192.540	196.710	201.640	149.130	153.440	151.920
79	197.600	197.470	197.550	195.100	195.340	194.640	198.800	203.770	151.440	155.500	153.560
80	197.300	197.010	197.110	194.640	194.790	194.130	198.670	203.730	145.550	149.690	147.390
81	196.600	196.400	196.450	193.780	194.090	193.400	197.900	202.960	144.400	148.780	146.480
82	197.140	196.950	196.980	194.250	194.590	193.970	198.450	203.540	144.410	149.490	147.660

- 103 -

channel number	26 1st stg noz inl press hub # 3 psig	27 1st stg noz inl press hub # 2 psig	29 1st stg noz inl press hub # 6 psig	31 1st stg noz inl press tip # 4 psig	32 1st stg noz inl press tip # 3 psig	33 1st stg noz inl press tip # 2 psig	36 1st stg noz inl press noz # 1 psig	37 1st stg noz inl press noz # 2 psig	39 1st stg noz exit press hub # 4 psig	40 1st stg noz exit press hub # 3 psig	41 1st stg noz exit press hub # 2 psig
83	197.690	197.460	197.720	194.900	195.330	194.520	199.100	204.160	144.540	150.500	147.060
84	196.360	196.250	196.660	193.640	193.740	193.330	197.820	202.760	143.430	147.200	147.410
85	196.720	196.680	197.180	194.100	194.300	193.780	198.310	203.250	144.560	148.250	148.470
86	196.190	196.110	196.490	193.360	193.520	193.010	197.830	202.900	138.820	142.830	142.630
87	194.210	193.950	194.280	191.330	191.690	190.950	195.700	200.890	137.640	143.860	139.480
88	196.780	196.600	196.650	193.860	194.150	193.510	198.250	203.440	139.490	145.590	142.410
89	194.530	194.420	194.450	191.700	191.920	191.420	196.130	201.320	137.500	142.160	140.100
90	195.450	195.240	195.330	192.690	192.880	192.180	197.010	202.180	139.310	143.490	140.890
91	197.520	197.270	197.360	194.670	194.800	194.140	199.270	204.450	139.730	141.000	138.180
92	197.060	196.700	196.780	194.030	194.250	193.460	198.620	203.830	138.690	140.970	137.390
93	197.490	197.350	197.320	194.590	194.790	194.180	199.140	204.270	138.000	142.130	139.160
94	196.690	196.310	196.760	193.640	194.160	193.210	198.310	203.510	137.860	144.510	137.060
95	196.720	196.520	197.250	193.700	193.750	193.410	198.390	203.420	137.800	138.770	137.530
96	195.180	195.030	195.780	192.370	192.530	192.000	196.850	201.770	141.180	141.990	140.930
97	196.410	196.060	196.650	193.570	193.920	192.980	197.900	202.820	143.420	147.290	140.440
98	196.290	196.010	196.220	193.280	193.590	192.870	197.710	202.720	140.960	146.090	141.830
99	197.020	196.770	197.050	194.120	194.480	193.750	198.540	203.510	142.030	147.020	142.910
100	195.670	195.480	195.550	192.860	193.150	192.440	197.270	202.340	141.460	143.760	140.930
101	196.380	196.120	196.300	193.670	193.790	193.010	197.940	202.960	143.270	144.480	141.780
102	198.490	198.170	198.340	195.790	195.920	195.240	199.870	204.690	149.340	150.260	147.910
103	197.000	196.690	196.920	194.300	194.550	193.770	198.390	203.220	148.540	150.250	147.480
104	197.330	197.150	197.310	194.650	194.920	194.270	198.730	203.580	147.940	150.810	148.640
105	198.530	198.140	198.650	195.580	196.080	195.150	199.760	204.530	148.740	153.580	147.900
106	199.640	199.410	200.240	196.790	196.980	196.430	201.140	205.810	149.410	150.160	149.140
107	197.740	197.730	198.460	195.570	195.830	195.230	198.630	202.860	166.120	166.460	166.130
108	196.310	196.040	196.680	194.070	194.420	193.600	196.990	201.210	165.880	167.760	164.580
109	197.150	197.080	197.480	194.960	195.360	194.680	197.930	202.130	165.780	168.040	166.470
110	196.420	196.240	196.530	194.300	194.520	193.790	197.240	201.430	165.700	166.720	165.720
111	196.780	196.700	196.830	194.630	194.940	194.230	197.520	201.800	166.700	167.050	166.120
112	0.080	-0.160	0.480	-0.070	-0.080	-0.410	0.150	0.680	0.650	0.210	0.050
113	200.200	200.440	201.010	199.310	199.650	199.100	199.540	202.300	199.660	200.270	201.000
114	0.000	-0.230	0.460	-0.070	-0.080	-0.450	0.150	0.680	0.650	0.210	0.020
115	0.010	-0.230	0.460	-0.080	-0.080	-0.450	0.150	0.670	0.590	0.220	0.010

NASA CR-179548
R/R/D 86-214

channel number	43 1st stg noz exit press slice number psig	45 1st stg noz exit press tip # 4 psig	46 1st stg noz exit press tip # 2 psig	48 1st stg noz exit press tip # 6 psig	49 1st stg noz exit noz # 1 psig	50 1st stg noz exit noz # 2 psig	51 2nd stg noz inl chamber press psig	53 2nd stg noz inl press hub # 4 psig	54 2nd stg noz inl press hub # 3 psig	55 2nd stg noz inl press hub # 2 psig	59 2nd stg noz inl press tip # 4 psig
1	0.040	0.000	-0.030	0.000	0.000	0.050	0.030	0.000	0.000	0.000	0.000
2	13.180	12.250	12.390	13.230	13.090	13.260	12.880	12.920	12.630	12.970	13.330
3	204.480	203.890	202.170	202.570	203.300	203.430	202.330	202.690	203.150	202.910	205.680
4	154.280	158.280	157.810	159.510	143.530	143.660	144.730	138.410	148.280	148.250	143.920
5	154.380	158.290	157.450	159.540	143.710	143.790	144.990	139.440	148.080	146.480	144.240
6	153.620	157.740	156.210	158.770	143.250	143.320	144.680	140.940	148.430	143.700	144.500
7	152.850	157.250	154.870	157.840	143.160	143.310	144.730	144.610	148.800	142.520	146.370
8	153.300	158.080	154.820	158.390	144.210	144.150	144.810	148.400	149.050	139.890	149.780
9	153.600	159.010	155.030	158.850	144.950	144.620	145.540	151.850	148.010	139.230	153.080
10	153.100	157.220	156.360	158.430	142.660	142.790	143.830	138.270	146.750	146.480	143.120
11	153.810	157.720	157.300	159.160	142.830	143.040	144.210	137.130	145.690	149.370	143.330
12	154.880	158.370	158.220	160.380	142.990	143.210	144.390	138.170	144.280	150.940	143.630
13	158.000	160.220	160.640	163.600	143.350	143.310	144.840	138.600	142.010	152.280	143.440
14	161.460	163.020	162.960	167.040	143.700	144.160	146.180	142.010	140.950	152.530	144.620
15	156.090	157.920	157.470	162.150	136.360	136.900	139.080	136.260	133.160	147.180	137.700
16	150.880	153.880	153.740	156.820	136.450	136.380	137.740	132.170	135.930	146.520	135.690
17	147.550	151.790	151.220	153.440	135.780	135.820	137.130	130.490	138.920	143.930	135.550
18	146.800	151.720	150.030	152.720	135.710	135.730	137.500	132.070	142.040	137.680	135.540
19	147.380	153.500	148.980	153.510	138.810	138.500	138.050	146.020	142.190	131.240	146.990
20	160.440	165.220	161.540	165.220	152.820	152.460	152.740	157.920	154.800	147.350	159.980
21	159.120	163.160	161.420	163.940	150.280	150.400	151.590	150.510	154.750	150.840	152.870
22	159.940	163.670	162.890	164.960	150.470	150.720	151.480	147.250	153.740	153.000	151.860
23	161.600	164.790	164.780	166.670	150.780	151.070	151.810	145.920	151.610	157.410	152.160
24	164.930	166.340	166.910	170.040	149.250	149.920	151.910	145.240	147.040	156.350	149.710
25	176.280	177.000	177.880	179.300	166.860	167.350	166.240	164.230	163.890	168.460	169.460
26	174.180	176.060	176.160	177.100	167.500	167.920	165.340	165.180	165.410	169.050	170.600
27	173.720	175.770	174.970	176.540	167.590	168.010	165.680	165.540	167.000	168.350	170.780
28	173.360	175.590	174.450	176.110	167.900	168.040	166.070	165.620	168.430	166.980	171.340
29	174.650	177.480	175.060	177.460	170.720	170.310	167.310	171.150	168.770	165.420	175.350
30	172.650	175.690	173.060	175.380	167.850	168.070	167.450	171.230	169.920	164.390	173.620
31	172.540	174.930	173.680	175.230	167.260	167.590	167.770	166.120	170.410	167.330	169.370
32	172.930	175.220	174.530	175.740	167.450	167.800	167.940	164.320	169.810	169.810	168.940
33	174.270	176.190						164.460	168.810	172.520	169.670
34	178.200	179.050						166.870	167.240	173.410	170.200
35	163.210	165.070						148.600	146.300	159.040	149.560
36	158.140	160.620						146.570	148.500	158.580	147.760
37	155.520	159.000						144.590	151.630	156.130	147.120
38	157.740	161.690						147.580	156.920	154.480	150.540
39	155.890	160.310						155.970	154.840	146.080	156.800
40	149.500	154.260						149.900	149.090	138.780	150.350
41	150.570	155.290						140.020	151.250	144.960	142.380

- 105 -

NASA CR-179548
R/RD 86-214

channel number	43 1st stg noz exit press hub # 6 psig	45 1st stg noz exit press tip # 4 psig	46 1st stg noz exit press tip # 2 psig	48 1st stg noz exit press tip # 6 psig	49 1st stg noz exit noz # 1 psig	50 1st stg noz exit noz # 2 psig	51 2nd stg noz inl chamber press psig	53 2nd stg noz inl press hub # 4 psig	54 2nd stg noz inl press hub # 3 psig	55 2nd stg noz inl press hub # 2 psig	59 2nd stg noz inl press tip # 4 psig
42	150.660	155.250						139.140	148.840	151.140	141.310
43	153.850	157.360						140.910	146.290	156.060	142.260
44	155.970	158.290						139.890	137.350	152.470	140.430
45	152.250	155.120						134.600	131.830	149.160	135.120
46	146.240	149.270						132.070	134.060	148.400	132.090
47	144.640	149.050						132.390	139.910	147.130	133.020
48	142.310	147.390						130.600	142.040	140.770	132.430
49	142.820	147.890						143.540	142.420	130.920	143.850
50	149.700	155.710						146.430	141.840	132.020	148.670
51	148.490	153.410						136.750	141.840	136.540	139.730
52	150.150	154.490						133.010	140.870	139.800	138.770
53	151.840	155.670						131.820	137.730	145.140	138.630
54	157.320	159.450						132.200	132.360	142.650	137.070
55	161.820	163.410						137.840	139.430	147.580	143.940
56	154.680	157.580						136.950	140.040	147.580	143.210
57	155.940	159.590						139.910	145.240	147.940	146.300
58	153.830	157.950						141.210	146.050	143.410	145.920
59	156.060	164.770						154.810	151.120	141.600	158.410
60	162.810	170.470						160.010	157.200	149.630	164.250
61	161.680	167.640						151.270	159.340	147.610	156.890
62	162.100	167.440						150.880	157.780	152.870	156.450
63	162.980	167.650						150.620	155.730	156.560	156.750
64	166.100	166.860						150.330	151.290	155.670	153.350
65	179.010	179.700	179.130	182.310	169.680	169.680	171.750	165.890	169.270	170.590	170.890
66	178.140	181.100	179.790	181.370	171.630	171.630	173.700	167.570	171.470	172.180	174.390
67	178.070	181.440	179.170	181.210	172.160	172.160	174.230	167.360	173.210	171.570	175.310
68	175.930	179.490	176.980	179.110	170.580	170.580	172.300	165.580	172.550	167.340	173.040
69	176.580	180.930	178.600	179.730	169.370	169.370	172.840	171.530	170.280	165.540	177.060
70	172.060	177.060	173.070	174.250	168.440	169.790	168.560	173.760	172.930	166.540	176.700
71	171.920	176.040	172.730	174.240	168.370	169.160	169.120	166.270	175.040	170.940	169.610
72	172.160	176.090	173.290	174.580	168.070	169.290	169.410	166.430	174.280	174.120	169.800
73	173.230	175.900	172.950	175.720	167.630	168.760	169.030	166.810	172.020	175.660	170.180
74	178.420	178.460	176.120	180.830	168.940	170.880	171.310	168.430	169.860	176.730	172.240
75	162.060	161.150	157.690	165.630	146.980	149.710	150.780	146.850	149.300	160.590	150.410
76	158.510	160.270	155.170	162.110	147.950	150.020	150.570	146.830	152.450	162.200	151.420
77	156.190	160.810	156.930	160.080	148.740	150.740	150.680	148.030	157.810	162.280	151.010
78	154.590	160.560	156.330	158.260	149.330	151.330	150.760	147.510	160.150	158.190	150.530
79	155.730	164.130	157.920	159.810	151.910	153.400	151.750	162.340	159.750	149.330	164.090
80	150.150	159.490	152.300	154.720	146.150	147.820	146.040	158.790	154.370	143.550	159.980
81	150.200	156.740	151.500	154.050	144.880	146.920	145.880	143.220	157.330	149.730	145.110
82	151.130	157.280	153.080	155.320	143.920	146.520	146.300	143.330	156.030	158.210	146.790

channel number	43 1st stg noz exit press hub # 6 psig	45 1st stg noz exit press tip # 4 psig	46 1st stg noz exit press tip # 2 psig	48 1st stg noz exit press tip # 6 psig	49 1st stg noz exit noz # 1 psig	50 1st stg noz exit noz # 2 psig	51 2nd stg noz inl chamber press psig	53 2nd stg noz inl press hub # 4 psig	54 2nd stg noz inl press hub # 3 psig	55 2nd stg noz inl press hub # 2 psig	59 2nd stg noz inl press tip # 4 psig
83	154.190	157.500	151.950	158.460	143.570	145.990	146.590	142.730	152.310	160.670	147.520
84	157.740	156.570	151.980	161.870	140.790	143.960	145.420	141.170	144.030	156.630	144.870
85	158.660	157.390	152.880	162.710	141.770	144.950	146.420	142.040	144.990	157.380	145.770
86	154.500	152.860	147.660	158.880	135.450	139.270	141.020	137.380	139.420	153.010	140.070
87	149.450	151.420	144.690	154.020	136.030	138.640	139.720	135.320	141.230	154.130	139.310
88	148.160	153.410	148.270	152.880	138.520	141.100	141.280	138.700	150.520	156.180	142.670
89	144.000	151.100	145.840	148.380	137.390	139.960	139.390	138.060	151.560	149.070	140.060
90	144.160	154.280	146.380	149.340	139.970	141.910	140.030	154.880	148.970	137.350	155.080
91	143.160	153.060	141.920	147.500	143.000	146.540	140.040	161.460	150.990	139.540	159.270
92	142.110	150.700	141.610	146.440	139.430	144.530	138.160	140.950	158.680	142.520	146.150
93	145.310	151.670	145.370	150.010	137.950	142.660	139.970	140.550	156.490	161.290	145.270
94	150.180	149.960	142.130	154.840	135.890	141.130	139.980	137.510	146.050	163.930	142.110
95	155.690	150.060	141.890	159.980	135.590	139.770	141.050	135.880	139.610	159.570	140.220
96	157.650	152.050	144.660	161.410	139.510	143.050	143.990	139.560	143.000	161.250	143.720
97	155.330	153.870	143.240	159.140	140.640	145.780	145.000	141.860	148.450	166.350	146.760
98	149.570	152.570	147.140	153.980	140.570	144.430	142.820	142.020	152.620	165.270	145.780
99	150.400	153.550	147.920	154.720	141.690	145.440	143.680	143.120	153.380	166.000	146.440
100	145.690	152.930	144.960	149.880	141.990	146.290	141.560	143.480	160.070	154.210	147.900
101	146.070	154.970	144.980	149.600	146.100	149.600	143.060	163.450	153.440	143.380	161.790
102	151.500	160.250	150.500	154.890	152.120	155.330	149.510	168.440	159.010	149.460	167.230
103	150.900	157.810	150.350	153.980	149.550	153.690	147.820	150.560	165.240	152.070	155.270
104	153.350	158.790	153.130	157.470	147.970	151.870	149.180	150.530	163.050	167.430	154.230
105	158.620	158.440	151.680	162.420	147.930	151.590	150.260	149.560	155.940	171.000	152.840
106	164.720	158.970	152.350	167.720	147.940	151.250	151.920	148.960	151.360	168.350	152.260
107	175.550	171.900	167.190	177.330	165.450	167.360	167.130	165.230	167.420	178.100	168.870
108	172.750	171.280	164.960	174.440	165.030	167.310	166.050	165.150	169.050	179.260	169.010
109	170.150	172.050	168.230	172.240	165.510	167.720	165.990	166.540	172.930	180.070	169.680
110	167.610	171.750	166.670	169.590	166.130	168.560	164.990	166.890	176.270	173.160	170.270
111	167.810	172.760	166.770	169.420	168.320	170.340	165.960	177.320	173.420	166.520	178.020
112	0.000	-0.600	-0.270	0.300	0.440	0.450	0.160	-0.760	0.220	0.380	0.240
113	200.230	199.980	198.480	198.860	199.310	199.700	198.320	198.050	199.060	199.030	201.660
114	0.000	-0.670	-0.310	0.300	0.440	0.450	0.160	-0.760	0.210	0.380	0.240
115	0.000	-0.600	-0.310	0.300	0.440	0.450	0.160	-0.760	0.220	0.450	0.240

- 107 -

channel number	60 2nd stg noz inl press tip # 3 psig	63 2nd stg noz inl noz # 2 psig	65 2nd stg noz exit press hub # 4 psig	66 2nd stg noz exit press hub # 3 psig	75 2nd stg noz exit press tip # 6 psig	76 2nd stg noz exit noz # 2 psig	78 exhaust manifold average psig
1	-0.030	0.080	0.000	0.000	-0.080	0.000	0.000
2	12.880	13.040	13.410	13.030	12.850	12.950	12.800
3	203.140	201.220	203.260	203.440	204.020	202.750	201.340
4	146.200	144.390	103.520	108.410	114.920	107.050	107.420
5	146.890	144.090	103.500	108.540	114.750	107.120	107.620
6	147.310	143.300	103.720	108.170	114.270	106.810	107.290
7	147.490	143.080	100.430	108.350	113.840	106.760	107.200
8	147.550	143.340	98.660	109.150	113.840	106.740	107.260
9	146.790	143.410	98.540	108.390	113.120	106.620	107.100
10	145.580	143.230	103.310	108.210	113.720	106.610	107.230
11	144.760	144.390	102.820	108.260	113.840	106.690	107.360
12	143.650	145.810	102.700	108.410	113.790	106.630	107.440
13	142.140	146.380	101.810	108.600	113.600	106.690	107.570
14	142.140	145.960	101.750	109.070	113.550	106.930	107.800
15	134.220	139.410	81.810	93.930	99.070	92.620	93.770
16	135.340	139.470	85.220	93.740	99.550	92.610	93.820
17	137.660	138.530	85.030	93.730	99.350	92.570	93.760
18	140.370	136.710	84.790	90.850	96.560	90.310	91.480
19	140.110	137.570	76.910	91.660	96.470	90.410	91.660
20	153.960	150.690	113.070	122.290	124.930	119.630	120.280
21	153.820	149.690	117.730	122.070	125.410	119.620	120.280
22	152.940	150.410	117.530	122.300	125.910	119.790	120.620
23	151.420	152.800	118.030	122.440	125.930	119.990	120.950
24	148.340	151.660	115.750	121.460	124.250	118.530	119.460
25	165.870	169.020	150.990	152.730	153.360	149.190	149.630
26	166.610	166.700	150.810	153.330	154.210	149.870	150.330
27	167.910	165.790	151.210	153.780	154.870	150.400	150.860
28	168.750	165.250	151.210	154.180	155.310	150.750	151.150
29	169.920	167.150	149.790	155.670	155.660	151.810	151.820
30	169.110	166.620	145.560	151.290	152.310	149.420	149.770
31	169.690	166.680	149.610	151.650	153.360	149.950	150.300
32	169.180	167.210	149.300	151.910	153.650	150.250	150.610
33	168.430	168.500	149.590		153.800	150.520	150.980
34	167.790	169.120	149.350		154.130	150.960	151.420
35	146.110	150.970	111.890		122.150	119.000	119.910
36	147.440	149.300	111.680		122.320	118.940	119.800
37	149.920	148.790	113.360		122.470	119.000	119.850
38	154.980	151.760	119.410		125.210	121.940	122.750
39	152.750	150.300	109.550		123.170	120.090	120.910
40	146.570	144.160	93.740		109.670	106.430	107.410
41	148.700	144.310	103.050		110.740	107.960	108.790

channel number	60 2nd stg noz inl press tip # 3 psig	63 2nd stg noz inl noz # 2 psig	65 2nd stg noz exit press hub # 4 psig	66 2nd stg noz exit press hub # 3 psig	75 2nd stg noz exit press tip # 6 psig	76 2nd stg noz exit noz # 2 psig	78 exhaust manifold average psig
42	146.590	143.930	97.130		109.370	106.240	107.270
43	144.500	144.370	97.250		109.750	106.580	107.580
44	136.960	142.600	95.170		106.780	104.270	105.390
45	131.400	138.080	80.660		94.240	91.740	93.020
46	132.340	134.990	80.850		94.600	91.720	92.890
47	137.580	136.300	79.150		93.800	90.820	92.000
48	139.780	135.730	79.640		93.400	90.890	91.930
49	139.740	137.430	74.420		93.620	90.910	92.020
50	141.020	137.680	82.060		98.860	92.020	93.200
51	140.860	136.500	87.740		99.350	91.950	93.120
52	140.050	137.730	88.300		100.060	92.010	93.280
53	137.640	140.330	87.740		100.180	91.970	93.420
54	134.650	140.870	88.530		99.210	91.610	93.050
55	141.810	149.270	106.110		113.240	105.950	107.360
56	140.760	144.260	105.960		112.770	105.540	106.970
57	145.010	144.360	106.830		115.050	107.330	108.770
58	145.750	142.150	104.150		113.420	105.820	107.040
59	150.950	152.510	94.940		113.080	105.740	106.960
60	157.840	159.360	111.380		126.900	119.760	120.760
61	158.660	151.970	111.440		126.820	118.110	119.330
62	157.820	152.410	112.050		126.770	118.370	119.650
63	156.340	153.280	112.600		126.420	118.280	119.710
64	152.940	156.430	113.950		124.780	117.350	118.740
65	171.220	172.460	152.200	154.330	156.480	151.420	152.310
66	173.280	170.950	152.420	154.960	157.580	152.040	152.890
67	174.380	170.290	152.930	155.350	158.510	152.370	153.240
68	173.410	167.960	151.020	153.500	157.130	150.500	151.380
69	172.160	169.280	149.200	156.040	156.800	150.660	151.470
70	172.080	168.990	146.370	149.480	152.710	151.510	151.790
71	173.670	169.070	146.850	147.150	151.910	150.610	151.040
72	172.940	169.310	147.720	146.670	152.000	150.570	150.990
73	170.780	169.140	147.220	146.790	151.820	150.340	150.730
74	169.600	170.450	151.820	149.860	153.690	152.060	152.550
75	148.060	149.970	114.770	112.180	119.790	118.240	119.100
76	149.830	151.550	115.890	112.160	121.300	119.430	120.040
77	155.500	152.530	113.400	110.380	119.890	118.760	119.180
78	158.120	151.680	113.980	110.740	119.250	118.850	119.190
79	158.590	153.550	109.440	112.690	119.820	119.920	120.280
80	153.870	148.210	94.160	97.760	105.910	107.250	107.590
81	155.270	147.300	99.370	96.630	106.250	107.050	107.400
82	153.440	147.970	100.410	96.680	107.010	107.160	107.470

- 109 -

NASA CR-179548
R/RD 86-214

channel number	60 2nd stg noz inl press tip # 3 psig	63 2nd stg noz inl noz # 2 psig	65 2nd stg noz exit press hub # 4 psig	66 2nd stg noz exit press hub # 3 psig	75 2nd stg noz exit press tip # 6 psig	76 2nd stg noz exit noz # 2 psig	78 exhaust manifold average psig
83	149.120	148.420	100.610	97.280	107.780	106.960	107.480
84	142.430	144.590	99.490	97.600	106.170	105.190	106.160
85	143.440	145.510	101.570	99.190	107.830	106.740	107.730
86	137.530	140.580	85.290	81.990	92.370	91.520	92.460
87	138.600	141.020	86.520	80.870	93.570	91.970	92.550
88	147.440	143.870	85.660	81.870	93.870	93.830	94.180
89	149.060	141.080	81.300	79.610	90.670	91.140	91.460
90	148.620	142.540	75.940	82.190	91.350	92.630	92.920
91	155.590	145.690	75.520	85.040	90.850	93.240	92.870
92	157.040	143.400	82.480	82.740	90.980	93.290	93.000
93	154.010	143.750	82.990	81.960	92.520	93.350	93.040
94	143.440	142.930	84.880	80.970	92.660	93.600	93.270
95	138.870	142.680	84.730	84.780	91.220	92.420	92.840
96	142.420	145.790	100.570	100.470	105.010	106.070	106.440
97	145.720	146.390	102.880	102.280	107.810	108.570	108.380
98	151.020	146.320	98.930	94.820	104.650	105.420	105.180
99	151.960	147.250	100.400	96.200	106.210	106.780	106.510
100	157.270	146.320	99.690	95.860	104.260	106.690	106.470
101	157.620	148.550	91.990	98.720	103.280	106.770	106.440
102	162.600	154.400	106.290	111.700	115.180	118.590	118.240
103	163.790	152.860	114.860	111.910	117.530	120.650	120.440
104	160.690	152.870	114.650	111.710	119.100	120.550	120.410
105	153.820	152.270	115.140	113.420	119.490	120.470	120.280
106	150.790	153.610	115.370	115.600	119.220	120.240	120.550
107	157.190	167.880	149.600	150.200	151.000	151.530	151.630
108	157.290	166.980	149.750	149.490	151.360	151.830	151.670
109	171.400	168.160	149.520	147.850	151.550	152.080	151.870
110	174.530	167.850	149.660	147.650	150.440	152.030	151.800
111	174.500	168.540	145.370	149.200	149.720	152.000	151.630
112	0.070	0.620	0.300	0.080	-2.170	0.060	1.030
113	199.020	197.560	199.370	199.650	198.100	198.320	198.000
114	0.080	0.610	0.300	0.080	-2.170	0.010	1.030
115	0.070	0.590	0.300	0.070	-2.170	0.050	1.030

constant parameters		constant parameters			constant parameters		constant parameters			
a	b	c	d	e	f	g	h	i	j	k
specific heat ratio	gas R (nitrogen) lbf-ft/lbm-f	atm pr psia	flow nozzle inlet dia (inch)	flow nozzle throat dia (inch)	turbine mean dia (inch)	mach no due to area ratio	tot to sta pressure ratio due to area ratio	critical flow parameter gamma	area of flow nozzle throat (in.sq.)	1st stage nozzle flow area (in.sq.)
1.4040	55.1644	14.3454	0.8700	0.2500	3.0000	0.0478	1.0016	0.8121	0.0491	2.6851
turbine seal leakage lbm/sec										
0.018										

- 1 1 1 -

channel number	1	2	3 new sonic nozzle	4 inlet manifold temperature	5 exhaust manifold temp	6 nozzle position degree	7 old sonic nozzle temp deg f	21 sonic noz u/s press psig	22 sonic noz thrt press psig	23 inlet manifold avg press psig	26 1st stg noz infl press hub # 3 psig
slice number	speed rpm	shaft torque in-lbf	temp deg f	deg F	deg f						
1	21072.9	13.440	68.350	79.900	-10.590	6	43.540	398.840	203.140	200.650	197.550
2	21066.4	13.850	67.980	78.410	-12.480	16	39.300	399.180	202.310	199.830	196.700
3	21077.2	13.400	68.010	77.480	-13.210	26	36.800	398.790	201.280	198.770	195.690
4	21081.6	13.260	67.660	76.730	-13.540	36	34.580	398.590	201.530	198.990	195.950
5	21070.7	13.020	67.940	75.300	-12.710	-4	31.930	398.370	204.540	202.050	199.030
6	21068.6	11.330	67.660	74.690	-11.410	-14	30.800	398.420	205.920	203.460	200.490
7	21068.6	11.160	67.790	73.840	-11.390	-24	29.130	397.740	205.960	203.490	200.540
8	21075.1	15.700	67.910	72.680	-21.100	-24	27.870	407.070	202.980	200.430	197.270
9	21075.1	16.680	67.650	72.250	-23.440	-4	27.440	409.930	203.410	200.810	197.630
10	21079.4	18.360	67.870	71.790	-25.840	6	26.770	410.350	201.710	199.090	195.870
11	21081.6	18.560	67.770	71.340	-27.380	16	26.310	410.550	199.950	197.290	194.040
12	21081.6	19.130	67.770	71.080	-27.830	36	26.050	411.060	199.550	196.930	193.650
13	21120.6	10.320	67.350	69.710	-11.670	36	24.050	389.570	205.030	202.660	199.760
14	21122.8	10.840	67.650	69.730	-12.430	16	24.200	388.230	203.700	201.360	198.410
15	21081.6	10.150	67.280	69.400	-12.060	6	23.940	386.990	204.340	201.990	199.060
16	21092.4	9.770	67.260	69.170	-10.350	-4	23.260	386.860	206.510	204.160	201.310
17	21098.9	7.810	67.840	68.850	-6.890	-24	23.010	375.610	204.890	202.650	199.940
18	21111.9	-0.090	67.840	69.060	13.220	-24	22.180	301.780	202.680	201.040	199.150
19	21105.4	0.240	68.080	69.130	13.150	-4	22.010	300.710	201.460	199.790	197.880
20	21096.8	0.680	69.200	69.130	12.380	6	21.490	300.690	200.350	198.720	196.780
21	21070.7	0.730	68.190	69.290	11.590	16	21.220	300.750	199.490	197.860	195.940
22	21096.8	0.760	68.080	69.330	12.130	36	21.560	300.960	200.710	199.090	197.210
23	15025.8	6.910	68.010	68.730	0.580	36	21.670	319.870	201.360	199.560	197.520
24	15017.1	6.920	67.890	68.540	-0.030	16	21.290	320.270	201.120	199.330	197.240
25	15030.1	6.600	67.980	68.480	0.050	6	21.330	320.860	202.600	200.810	198.720
26	15038.8	5.900	68.050	68.190	0.950	-4	21.060	321.030	204.100	202.300	200.240
27	15019.2	5.430	67.940	68.060	1.850	-24	21.020	321.470	205.990	204.190	202.160
28	15021.4	14.290	67.800	67.260	-12.820	-24	21.760	382.490	203.840	201.550	198.750
29	15006.2	14.800	67.720	67.130	-14.060	-4	21.850	382.370	203.210	200.900	198.090
30	15034.4	15.880	67.980	66.770	-15.290	6	21.870	382.720	202.000	199.680	196.820
31	15058.3	16.070	67.860	66.590	-16.220	16	21.710	382.840	200.460	198.100	195.210
32	15053.9	16.250	68.010	66.450	-16.420	36	21.920	382.840	199.700	197.320	194.470
33	15038.8	22.820	67.120	65.780	-25.090	36	22.660	413.560	203.960	201.360	198.070
34	15038.8	22.500	66.890	65.680	-25.670	16	22.810	413.010	203.960	201.370	198.100
35	15080.0	21.590	67.050	65.750	-25.020	6	22.570	413.040	205.660	203.030	199.790
36	15075.6	20.060	66.860	65.590	-22.900	-4	22.840	407.260	204.680	202.110	198.970
37	15073.5	18.980	67.000	65.470	-21.070	-24	22.520	407.450	206.090	203.560	200.440
38	15058.3	24.000	66.870	65.420	-28.510	-24	22.900	416.690	203.490	200.860	197.520
39	15077.8	24.370	67.140	65.080	-29.470	-4	22.990	417.050	203.250	200.580	197.250
40	15093.0	25.620	66.770	65.050	-30.800	6	23.020	416.960	201.680	199.010	195.690
41	15058.3	27.120	66.770	64.820	-32.800	16	23.130	417.990	200.240	197.540	194.160

channel number	1	2	3 new sonic nozzle	4 inlet manifold temperature deg F	5 exhaust manifold temp deg f	6 nozzle position degree	7 old sonic nozzle temp deg f	21 sonic noz u/s press psig	22 sonic noz thrt press psig	23 inlet manifold avg press psig	26 1st stg noz inl press hub # 3 psig
slice number	speed rpm	shaft torque in-lbf	temp deg f	temperature deg F	temp deg f	degree	temp deg f	psig	psig	psig	psig
=====	=====	=====	=====	=====	=====	=====	=====	=====	=====	=====	=====
42	15069.1	27.590	66.680	64.750	-32.990	36	23.220	418.520	199.200	196.490	193.080
43	25058.1	14.870	67.470	64.890	-28.750	36	21.960	419.880	204.350	201.650	198.350
44	25088.5	15.270	67.860	65.290	-29.620	16	21.960	420.450	204.010	201.360	197.970
45	25114.5	15.200	67.840	65.330	-28.900	6	21.920	420.390	205.460	202.820	199.460
46	25108.0	13.750	67.930	65.640	-24.360	-4	22.210	410.890	204.190	201.610	198.380
47	25112.3	13.060	67.660	65.820	-22.090	-24	22.010	411.400	206.280	203.750	200.570
48	25129.6	8.740	67.540	65.960	-10.800	-24	21.580	389.320	203.770	201.380	198.480
49	25147.0	9.270	68.010	65.960	-11.090	-4	21.220	390.470	203.540	201.130	198.150
50	10049.7	11.010	68.630	65.770	-1.350	-4	21.760	319.550	202.600	200.830	198.750
51	10030.2	9.970	68.960	65.270	-0.410	-24	21.350	319.540	203.350	201.580	199.520
52	10051.9	10.760	68.770	64.520	-1.570	6	21.270	319.760	202.100	200.300	198.240
53	10043.2	11.150	68.750	64.220	-1.680	16	20.660	319.820	201.110	199.340	197.240
54	10023.7	11.050	68.520	64.050	-1.550	37	20.860	319.830	200.810	199.030	196.960
55	10041.0	25.340	68.580	63.870	-16.180	37	22.140	401.970	202.890	200.410	197.240
56	10049.7	24.990	68.120	63.890	-16.220	16	22.560	401.960	203.790	201.330	198.170
57	10056.2	23.770	68.210	63.380	-14.950	6	22.590	401.690	205.750	203.290	200.180
58	10041.0	21.690	67.890	62.960	-13.410	-4	22.680	394.520	204.190	201.810	198.810
59	10049.7	20.820	67.720	62.920	-12.460	-24	22.610	394.450	205.520	203.130	200.200
60	10006.3	24.550	67.700	62.690	-16.070	-24	23.390	404.160	202.660	200.180	197.070
61	10012.8	24.860	67.590	62.690	-16.110	-4	23.400	403.310	202.030	199.510	196.350
62	10010.7	25.990	67.510	62.520	-17.260	6	23.550	402.950	199.980	197.460	194.290
63	10015.0	29.040	68.300	61.970	-18.960	16	24.070	419.150	204.610	202.020	198.590
64	10023.7	29.600	67.790	61.970	-19.070	36	24.500	418.170	201.670	199.030	195.580
65	9991.1	36.220	68.100	62.060	-21.830	36	26.160	430.500	200.920	198.150	194.500
66	10010.7	34.770	68.210	62.170	-19.270	16	27.530	429.110	201.620	198.850	195.240
67	10019.3	33.460	68.560	61.850	-16.140	6	28.840	428.600	203.160	200.390	196.840
68	10017.2	31.370	68.580	62.110	-13.080	-4	30.080	428.050	204.930	202.180	198.760
69	10012.8	30.980	68.800	61.940	-10.650	-24	31.770	427.490	205.760	203.060	199.610
70	25019.1	9.920	68.820	64.840	-0.690	6	34.420	396.580	202.100	199.650	196.580
71	25016.9	10.730	68.860	65.260	-1.840	16	34.850	396.280	199.900	197.440	194.340
72	25027.7	10.570	69.030	65.800	-0.450	36	35.440	396.120	200.500	198.030	195.010
73	663.5	54.390	69.210	64.080	22.450	36	38.050	442.550	203.090	200.230	196.340
74	667.8	51.380	69.260	63.640	22.820	16	38.550	441.940	205.030	202.130	198.340
75	776.2	49.210	69.290	63.340	23.020	6	38.680	440.770	206.310	203.410	199.700
76	678.7	45.730	69.290	63.100	23.740	-4	38.980	431.980	204.690	201.850	198.280
77	670.0	45.000	69.350	62.940	23.980	-24	39.320	431.470	204.470	201.710	198.110
78	652.6	38.590	69.540	62.570	25.010	-24	39.410	415.730	202.880	200.300	196.900
79	622.3	38.240	68.910	62.460	25.120	-4	39.480	415.060	202.860	200.240	196.880
80	741.5	39.630	69.150	62.590	25.080	6	39.520	414.900	201.460	198.800	195.420
81	761.0	41.110	69.070	62.620	25.080	16	39.640	414.820	199.480	196.810	193.390
82	784.9	47.550	69.140	62.390	24.700	36	39.620	432.470	202.610	199.780	196.110

- 1 1 3 -

channel number	1	2	3 new sonic nozzle	4 inlet manifold temperature	5 exhaust manifold temp	6 nozzle position degree	7 old sonic nozzle temp	21 sonic noz u/s press psig	22 sonic noz thrt press psig	23 inlet manifold avg press psig	26 1st stg noz inl press hub # 3 psig
slice number	speed rpm	shaft torque in-lbf	temp deg f	temperature deg F	temp deg f		deg f				
83	678.7	41.820	69.610	62.150	25.400	36	39.840	420.150	203.070	200.440	196.930
84	700.3	39.380	69.430	62.130	25.640	16	39.860	418.700	204.740	202.110	198.660
85	758.9	35.860	69.400	61.990	26.140	6	40.020	408.440	203.860	201.290	198.090
86	769.7	34.090	69.430	61.830	26.380	-4	40.070	407.750	205.810	203.330	200.090
87	722.0	33.450	69.560	61.800	26.430	-24	40.180	407.100	205.590	203.080	199.890
88	722.0	20.410	69.450	61.920	28.660	-24	39.910	341.790	203.500	201.550	199.230
89	624.4	20.390	69.470	61.970	28.730	-4	39.770	341.270	203.520	201.570	199.280
90	730.7	21.100	69.380	61.920	28.790	6	39.610	340.350	202.130	200.190	197.860
91	654.8	21.910	69.560	61.950	28.730	16	39.410	340.080	200.720	198.770	196.440
92	722.0	25.210	69.560	62.010	28.500	36	39.200	353.150	201.170	199.150	196.570
93	25055.9	5.110	69.400	63.610	9.890	6	39.090	390.160	206.170	203.820	200.880
94	25105.8	5.740	69.100	64.270	10.000	16	39.180	389.570	205.160	202.800	199.870
95	25144.8	5.510	69.240	64.800	11.130	36	38.840	389.370	206.140	203.780	200.910
96	25166.5	5.090	69.540	65.610	13.090	-4	39.180	388.270	207.880	205.600	202.710
97	24741.5	4.190	69.560	66.640	17.310	-24	38.790	371.990	203.960	201.790	199.100
98	25374.7	3.880	69.730	66.680	18.740	-24	39.020	371.620	204.160	201.930	199.280
99	25068.9	4.430	69.870	67.100	18.470	-24	38.770	371.160	203.820	201.620	198.980
100	25318.3	-2.650	69.800	67.750	40.820	-24	38.020	295.620	202.190	200.610	198.800
101	25108.0	-2.260	69.750	68.220	41.210	-4	38.230	295.230	201.170	199.580	197.700
102	25064.6	-1.800	69.820	68.550	40.130	6	38.320	295.050	199.550	197.950	196.070
103	25398.5	-1.690	69.990	68.890	40.390	16	38.180	294.820	198.430	196.810	194.910
104	25363.8	-1.750	70.010	69.150	40.770	36	38.210	294.650	199.200	197.580	195.750
105	0.0	3.130	69.940	69.830	37.820	0	43.850	0.230	-0.070	0.090	0.080
106	34973.4	342.830	69.920	70.290	39.300	0	44.350	0.230	0.000	0.120	0.050
107	284.0	2.720	69.990	70.690	48.910	0	49.430	205.450	205.870	205.460	205.210

- 1 1 4 -

NASA CR-179548
R/RD 86-214

Two Stage Partial Admission Turbine Test (NAS3-23773) Test No 9 : 1/2 DESIGN CONFIGURATION TEST DATE 16 DEC 1985

channel number	27 1st stg noz inl press hub # 2 psig	29 1st stg noz inl press hub # 6 psig	32 1st stg noz inl press tip # 3 psig	33 1st stg noz inl press tip # 2 psig	36 1st stg noz inl noz # 1 psig	37 1st stg noz inl noz # 2 psig	40 1st stg noz exit press hub # 3 psig	41 1st stg noz exit press hub # 2 psig	43 1st stg noz exit press hub # 6 psig	48 1st stg noz exit press tip # 6 psig	50 1st stg noz exit noz # 2 psig
1	197.580	198.780	195.360	195.340	199.780	202.270	147.110	141.280	152.140	156.340	140.880
2	196.790	197.920	194.500	194.530	198.910	201.470	145.970	140.300	150.730	154.860	140.360
3	195.710	196.900	193.490	193.510	197.970	200.460	144.930	138.670	149.640	153.730	139.980
4	195.970	197.130	193.740	193.680	198.120	200.680	145.570	139.120	150.070	154.400	141.190
5	199.050	200.250	196.870	196.790	201.100	203.700	150.020	143.360	154.650	158.980	142.440
6	200.500	201.680	198.340	198.220	202.540	205.080	152.220	145.150	156.600	160.990	143.510
7	200.510	201.730	198.380	198.250	202.530	205.110	152.530	145.200	157.030	161.470	143.090
8	197.260	198.480	195.010	194.940	199.450	202.130	144.960	136.580	149.700	154.270	134.710
9	197.680	198.880	195.360	195.310	199.920	202.530	144.230	136.350	149.160	153.720	135.070
10	195.890	197.120	193.540	193.540	198.280	200.830	141.050	133.650	146.350	150.900	133.370
11	194.060	195.260	191.670	191.720	196.500	199.070	137.940	131.220	143.260	147.730	131.560
12	193.650	194.870	191.280	191.380	195.970	198.660	137.410	130.210	142.290	147.220	132.860
13	199.760	200.940	197.680	197.610	201.710	204.290	154.070	148.050	158.310	162.280	149.840
14	198.480	199.580	196.260	196.300	200.480	202.960	152.290	147.060	156.480	160.330	147.470
15	199.130	200.270	196.930	196.900	200.950	203.580	153.270	148.500	157.690	161.670	147.910
16	201.340	202.480	199.170	199.130	203.160	205.730	156.470	150.920	161.010	165.120	149.710
17	199.940	201.080	197.910	197.880	201.650	204.210	158.190	152.150	162.050	166.080	150.040
18	199.340	200.100	197.650	197.570	200.190	202.650	173.050	171.160	175.500	177.830	167.900
19	198.090	198.850	196.370	196.300	198.920	201.420	171.410	170.070	174.310	176.590	167.550
20	197.000	197.750	195.280	195.270	197.840	200.360	170.130	168.810	172.910	175.120	167.170
21	196.140	196.860	194.420	194.310	196.970	199.480	169.390	167.620	171.620	173.840	166.990
22	197.330	198.140	195.730	195.550	198.060	200.700	171.390	168.690	173.780	175.940	169.060
23	197.620	198.510	195.920	195.770	198.600	201.220	168.620	165.960	171.240	173.240	166.700
24	197.390	198.230	195.610	195.550	198.360	200.970	167.930	165.790	170.650	172.600	165.750
25	198.870	199.720	197.070	197.000	199.790	202.420	169.350	167.470	172.240	174.240	166.850
26	200.370	201.250	198.620	198.590	201.320	203.900	171.240	168.880	174.120	176.140	167.940
27	202.240	203.140	200.530	200.380	203.170	205.730	173.580	170.530	176.410	178.570	169.060
28	198.720	199.880	196.620	196.570	200.520	203.160	154.880	149.760	159.580	162.650	149.340
29	198.090	199.240	195.970	195.950	200.040	202.540	153.940	149.420	158.360	161.410	149.540
30	196.820	197.950	194.680	194.710	198.840	201.330	152.120	147.870	156.180	159.260	148.020
31	195.270	196.320	193.050	193.130	197.250	199.780	149.650	145.800	153.860	156.980	146.390
32	194.480	195.550	192.290	192.380	196.450	199.020	149.020	144.720	152.600	156.130	146.840
33	198.040	199.270	195.700	195.870	200.490	203.030	143.450	138.410	147.590	151.940	141.040
34	198.100	199.300	195.690	195.830	200.450	203.050	143.360	138.600	148.300	152.130	139.780
35	199.790	201.030	197.430	197.540	202.040	204.700	146.130	141.020	150.830	154.590	141.880
36	198.950	200.160	196.620	196.690	201.170	203.800	147.120	141.660	152.030	155.680	142.720
37	200.390	201.670	198.130	198.120	202.540	205.210	149.300	143.020	154.730	158.380	143.110
38	197.480	198.750	195.090	195.210	199.870	202.550	141.290	134.430	147.230	151.360	134.820
39	197.230	198.490	194.820	194.990	199.680	202.290	140.720	134.190	146.100	150.190	135.650
40	195.680	196.920	193.230	193.400	198.190	200.800	138.090	132.240	143.210	147.360	133.820
41	194.110	195.390	191.640	191.870	196.600	199.310	134.920	129.620	140.050	144.230	130.830

- 1 1 5 -

channel number	27 1st stg noz inl press hub # 2 psig	29 1st stg noz inl press hub # 6 psig	32 1st stg noz inl press tip # 3 psig	33 1st stg noz inl press tip # 2 psig	36 1st stg noz inl noz # 1 psig	37 1st stg noz inl noz # 2 psig	40 1st stg noz exit press hub # 3 psig	41 1st stg noz exit press hub # 2 psig	43 1st stg noz exit press hub # 6 psig	48 1st stg noz exit press tip # 6 psig	50 1st stg noz exit noz # 2 psig
42	193.050	194.270	190.550	190.780	195.620	198.290	133.060	127.620	137.490	142.260	130.580
43	198.250	199.590	195.890	195.980	200.660	203.400	141.040	132.630	146.200	151.520	135.080
44	197.940	199.220	195.500	195.720	200.460	203.080	140.030	132.240	145.030	150.050	132.880
45	199.420	200.700	196.970	197.090	201.810	204.520	142.060	134.910	147.420	152.500	134.000
46	198.330	199.640	196.010	196.110	200.710	203.380	144.320	136.630	149.710	154.660	135.010
47	200.450	201.790	198.210	198.200	202.700	205.440	147.850	139.080	152.590	157.710	136.270
48	198.450	199.680	196.310	196.330	200.470	203.160	152.040	145.140	156.170	160.820	141.990
49	198.120	199.370	195.950	196.010	200.140	202.880	150.690	144.660	155.550	160.130	142.350
50	198.840	199.750	197.110	196.990	199.810	202.440	170.290	168.240	172.860	174.480	168.560
51	199.560	200.510	197.880	197.720	200.520	203.180	171.200	168.840	174.070	175.700	168.600
52	198.330	199.230	196.560	196.550	199.440	201.950	169.500	167.940	171.960	173.610	168.220
53	197.330	198.220	195.580	195.540	198.480	201.000	168.200	166.990	170.690	172.300	166.990
54	197.050	197.920	195.300	195.180	198.150	200.710	168.180	166.570	170.240	172.120	167.480
55	197.270	198.460	194.890	195.100	199.540	202.150	146.580	143.970	149.940	153.560	146.390
56	198.240	199.350	195.850	196.090	200.300	203.020	147.570	145.120	151.330	154.750	146.930
57	200.220	201.400	197.900	198.050	202.270	204.970	150.860	147.810	154.460	157.950	149.410
58	198.820	200.010	196.580	196.690	200.790	203.540	151.600	148.020	154.910	158.400	149.570
59	200.150	201.340	197.950	198.030	202.140	204.840	153.770	149.320	157.460	161.020	150.340
60	196.980	198.200	194.650	194.760	199.190	201.910	145.850	140.960	149.890	153.910	142.250
61	196.300	197.530	194.020	194.120	198.650	201.280	145.180	140.600	148.810	152.720	142.450
62	194.250	195.420	191.880	192.070	196.580	199.240	141.820	138.380	145.410	149.260	140.050
63	198.630	199.870	196.110	196.380	201.000	203.740	141.740	138.660	146.120	150.060	140.800
64	195.590	196.820	193.070	193.400	198.170	200.830	137.490	134.660	141.510	145.360	137.440
65	194.540	195.750	191.850	192.220	197.250	199.960	129.660	126.600	134.220	138.390	129.650
66	195.300	196.540	192.610	193.000	197.880	200.670	131.440	128.470	136.390	140.610	130.890
67	196.870	198.120	194.270	194.610	199.460	202.200	135.140	131.500	139.530	143.760	133.800
68	198.690	199.960	196.130	196.380	201.230	203.950	138.840	134.420	143.060	147.420	136.530
69	199.520	200.840	197.040	197.240	202.140	204.790	140.730	135.240	145.440	149.980	136.870
70	196.520	197.780	194.230	194.340	198.690	201.440	146.700	140.750	151.750	156.340	139.440
71	194.280	195.500	192.000	192.150	196.510	199.250	143.800	137.940	147.910	152.570	137.690
72	194.910	196.210	192.710	192.740	197.050	199.880	145.230	138.070	149.770	154.480	140.140
73	196.460	197.670	193.570	194.140	199.320	202.080	126.310	125.320	130.550	134.280	130.060
74	198.430	199.700	195.600	196.100	201.140	203.950	130.760	128.870	135.670	140.030	132.860
75	199.790	201.050	197.020	197.460	202.510	205.230	134.640	131.700	138.760	143.030	136.260
76	198.310	199.550	195.620	196.120	200.920	203.690	136.250	134.460	139.850	144.190	137.340
77	198.110	199.400	195.490	195.790	200.800	203.510	136.410	133.000	140.310	145.050	136.160
78	196.910	198.100	194.410	194.690	199.340	202.010	141.670	138.650	141.980	149.280	141.550
79	196.910	198.110	194.430	194.700	199.280	202.000	142.030	139.090	144.730	148.970	142.650
80	195.500	196.690	192.910	193.310	197.950	200.600	139.620	137.730	142.960	146.450	141.040
81	193.470	194.670	190.870	191.300	195.980	198.670	136.330	134.210	139.960	143.820	138.100
82	196.240	197.380	193.410	193.970	198.950	201.610	131.880	131.200	135.670	139.060	135.750

NASA CR-179548
R/RD 86-214

channel number	27 1st stg noz inl press hub # 2 psig	29 1st stg noz inl press hub # 6 psig	32 1st stg noz inl press tip # 3 psig	33 1st stg noz inl press tip # 2 psig	36 1st stg noz inl noz # 1 psig	37 1st stg noz inl noz # 2 psig	40 1st stg noz exit press hub # 3 psig	41 1st stg noz exit press hub # 2 psig	43 1st stg noz exit press hub # 6 psig	48 1st stg noz exit press tip # 6 psig	50 1st stg noz exit noz # 2 psig
83	197.050	198.200	194.370	194.860	199.560	202.230	139.420	139.020	142.580	145.630	143.160
84	198.760	197.960	196.150	196.580	201.150	203.860	142.950	141.620	146.690	150.530	145.090
85	198.110	199.310	195.650	195.920	200.290	203.080	146.590	144.390	149.520	152.730	148.170
86	200.190	201.330	197.680	198.010	202.330	205.040	149.600	148.280	152.150	155.460	150.670
87	199.900	201.110	197.490	197.680	202.120	204.800	149.660	146.930	152.540	156.320	149.610
88	199.320	200.300	197.380	197.480	200.580	203.250	167.060	165.740	168.800	170.860	167.080
89	199.340	200.270	197.400	197.480	200.570	203.240	167.230	166.050	168.630	170.740	167.760
90	197.970	198.880	196.000	196.170	199.380	201.900	165.620	165.100	167.340	168.910	166.590
91	196.560	197.450	194.550	194.700	197.950	200.490	163.960	163.370	165.780	167.580	165.260
92	196.730	197.670	194.620	194.870	198.260	200.870	160.770	161.050	162.550	163.990	163.440
93	200.870	202.100	198.680	198.770	202.830	205.550	154.670	149.960	158.870	163.190	148.900
94	199.890	201.080	197.670	197.790	201.930	204.540	153.640	148.780	157.320	161.680	148.480
95	200.800	202.100	198.710	198.680	202.760	205.490	155.530	149.290	159.740	164.060	151.150
96	202.660	203.940	200.520	200.560	204.520	207.270	157.610	152.490	162.290	166.610	150.510
97	199.080	200.250	197.060	197.050	200.770	203.480	157.970	152.390	161.570	165.750	149.200
98	199.250	200.410	197.220	197.250	200.940	203.640	158.140	152.800	161.770	165.990	149.380
99	199.000	200.120	196.930	196.930	200.750	203.360	157.960	152.570	161.530	165.720	149.180
100	198.950	199.750	197.250	197.250	199.590	202.200	172.940	171.910	175.400	178.310	168.000
101	197.860	198.680	196.130	196.180	198.740	201.200	171.370	170.760	174.560	177.350	167.850
102	196.230	197.050	194.510	194.580	197.120	199.590	169.560	168.810	172.550	175.300	166.950
103	195.100	195.860	193.370	193.380	196.020	198.460	168.610	167.330	170.940	173.700	166.770
104	195.860	196.700	194.230	194.150	196.600	199.210	170.310	167.920	172.530	175.220	168.210
105	0.000	0.150	-0.080	-0.220	0.150	0.220	0.000	0.000	-0.010	0.070	0.150
106	0.000	0.150	-0.080	-0.240	0.110	0.220	0.000	0.000	0.000	0.070	0.150
107	205.560	205.830	204.770	204.250	204.410	206.770	205.050	205.880	205.250	203.560	204.350

- 117 -

NASA CR-179548
R/RD 86-214

channel number	51 2nd stg noz inl chamber press	54 2nd stg noz inl press hub # 3	60 2nd stg noz inl press tip # 3	63 2nd stg noz inl noz # 2	66 2nd stg noz exit press hub # 3	75 2nd stg noz exit press tip # 6	76 2nd stg noz exit noz # 2	77 2nd stg noz exit chamber press	78 exhaust manifold average
slice number	psig	psig	psig	psig	psig	psig	psig	psig	psig
1	139.890	139.710	139.450	140.240	109.400	114.600	107.190	105.550	107.490
2	139.600	140.830	140.230	139.430	109.430	114.490	107.200	105.480	107.480
3	139.040	141.470	141.450	138.640	109.590	113.680	107.140	105.430	107.400
4	139.980	139.040	140.930	139.750	111.190	114.280	107.030	105.340	107.270
5	141.860	139.490	140.060	142.060	109.250	114.570	106.970	105.510	107.330
6	143.860	140.320	141.290	144.160	109.290	114.340	107.130	105.620	107.560
7	143.890	139.210	140.770	144.530	110.380	113.800	106.910	105.330	107.220
8	136.080	130.710	131.510	137.030	94.760	98.300	91.400	89.960	92.000
9	135.780	131.460	132.140	135.960	93.440	98.960	91.620	90.170	92.250
10	132.960	130.490	130.620	132.900	93.360	99.200	91.740	90.210	92.290
11	131.040	131.860	131.040	130.700	93.260	99.200	91.780	90.210	92.220
12	131.760	130.610	132.650	131.440	95.110	99.390	92.060	90.480	92.470
13	148.430	148.220	149.660	148.400	124.770	127.080	120.290	118.460	120.510
14	146.380	148.720	148.720	146.240	122.660	126.370	119.880	118.040	120.010
15	146.790	147.490	147.310	147.020	122.520	126.980	119.670	117.910	119.890
16	148.900	147.320	148.080	149.100	122.350	127.030	119.600	118.030	119.960
17	149.670	146.930	148.750	150.610	124.400	127.680	121.350	119.630	121.430
18	166.560	165.770	168.040	167.300	155.610	157.000	151.920	149.960	151.700
19	165.980	165.930	167.620	166.490	154.930	156.970	151.790	149.860	151.690
20	165.280	166.010	167.520	165.820	155.120	157.370	151.970	149.970	151.840
21	164.830	166.340	168.040	165.370	155.620	157.730	152.270	150.170	152.100
22	166.380	168.120	169.660	167.270	156.280	158.060	152.620	150.640	152.580
23	165.550	165.510	166.600	164.960	153.220	155.140	150.310	148.510	150.020
24	164.880	166.710	166.500	164.160	152.060	154.650	150.390	148.570	150.000
25	165.970	166.530	166.500	165.500	152.860	155.710	151.010	149.260	150.670
26	167.250	166.500	166.780	166.800	152.930	155.870	151.080	149.450	150.820
27	168.990	167.010	168.040	168.880	153.630	156.100	151.700	149.980	151.320
28	150.330	146.140	146.850	149.470	120.750	124.490	120.030	118.470	120.090
29	149.700	146.180	146.320	149.380	120.490	124.670	119.890	118.300	119.970
30	147.580	145.920	145.370	147.740	120.580	124.910	119.960	118.310	119.970
31	146.000	146.880	146.190	145.280	120.720	124.990	120.250	118.620	120.180
32	146.070	146.570	146.520	145.410	120.820	124.670	120.280	118.630	120.250
33	140.380	141.650	140.820	139.730	106.620	111.170	107.540	105.920	107.690
34	139.660	142.080	140.790	138.710	106.640	111.650	107.370	105.710	107.420
35	141.580	140.590	139.190	141.480	107.010	112.020	107.470	105.800	107.440
36	142.330	138.900	138.620	142.110	105.750	110.890	106.420	104.740	106.520
37	144.400	139.840	140.440	143.660	106.320	110.780	106.720	105.110	106.970
38	136.150	131.420	131.870	135.590	89.390	94.410	90.890	89.290	91.290
39	135.330	130.960	130.820	135.260	89.030	94.780	90.630	88.970	91.100
40	133.420	130.270	129.350	133.120	88.820	94.880	90.840	89.070	90.970
41	130.710	131.130	129.400	130.430	88.710	94.120	90.710	88.940	90.860

channel number	51 2nd stg noz inl chamber press psig	54 2nd stg noz inl press hub # 3 psig	60 2nd stg noz inl press tip # 3 psig	63 2nd stg noz inl noz # 2 psig	66 2nd stg noz exit press hub # 3 psig	75 2nd stg noz exit press tip # 6 psig	76 2nd stg noz exit noz # 2 psig	77 2nd stg noz exit chamber press psig	78 exhaust manifold average psig
42	130.270	131.290	130.210	129.480	88.900	93.510	90.790	89.070	91.170
43	133.470	132.740	134.590	133.860	96.830	99.700	91.180	89.420	92.070
44	131.640	134.100	134.340	131.920	95.220	99.830	91.360	89.590	92.210
45	132.660	132.980	132.840	133.460	95.110	100.620	91.330	89.550	92.240
46	133.850	131.770	132.660	134.700	95.150	100.690	91.500	89.900	92.470
47	136.100	131.990	134.650	137.560	96.670	100.180	92.030	90.270	92.920
48	141.110	138.310	140.920	142.700	112.050	114.590	107.260	105.340	107.770
49	140.990	139.570	140.850	141.970	110.830	115.580	107.390	105.610	108.270
50	167.900	166.110	166.180	167.210	152.030	154.660	151.760	149.710	151.320
51	168.760	166.810	167.250	167.830	152.700	154.980	152.220	150.170	151.760
52	167.600	166.510	166.050	166.880	152.750	155.440	152.520	150.420	152.020
53	166.450	167.650	166.780	165.570	153.090	155.420	152.720	150.650	152.160
54	166.730	167.570	167.230	165.790	153.170	155.320	153.080	151.010	152.550
55	145.590	148.810	147.490	145.090	119.230	121.680	120.660	118.670	120.620
56	146.120	148.600	146.660	145.620	119.370	122.360	120.730	118.710	120.590
57	148.560	146.810	145.590	148.240	118.760	123.070	120.930	118.870	120.700
58	148.730	145.830	145.540	149.020	118.100	122.190	119.980	117.940	119.780
59	150.700	147.040	147.520	150.070	119.340	122.030	120.140	118.180	120.140
60	142.660	138.720	138.970	142.060	105.180	108.130	106.860	104.970	107.010
61	141.780	138.660	137.660	142.510	104.390	108.560	106.730	104.750	106.790
62	138.970	136.280	135.650	139.580	103.710	108.250	106.640	104.630	106.640
63	139.830	139.490	137.380	139.650	103.990	108.880	107.380	105.320	107.370
64	136.530	140.970	139.560	136.290	104.380	107.320	106.920	104.910	107.020
65	128.850	133.730	132.330	128.550	88.340	91.660	92.200	90.220	92.450
66	130.070	132.040	130.060	129.830	87.610	92.450	91.930	89.940	92.040
67	132.720	130.290	129.000	133.230	87.240	92.760	92.030	90.010	92.100
68	135.400	131.860	131.080	136.260	87.710	93.040	92.040	90.060	92.170
69	137.510	132.940	133.020	136.920	88.190	91.970	91.950	89.970	92.130
70	137.970	137.540	137.950	138.880	109.150	113.550	105.200	103.150	105.970
71	136.360	137.900	138.450	136.800	109.240	113.330	105.420	103.210	106.000
72	138.140	138.200	139.930	138.910	110.970	113.070	105.710	103.580	106.400
73	128.790	135.920	136.720	128.560	87.760	88.830	92.890	90.660	92.850
74	130.000	132.860	130.650	131.230	83.340	88.580	92.920	90.780	92.840
75	133.030	133.860	132.190	134.580	83.300	88.160	92.750	90.430	92.600
76	134.440	134.510	132.270	135.630	83.450	87.970	92.290	89.970	92.170
77	136.850	134.530	132.630	134.850	84.630	89.060	92.000	89.960	92.050
78	142.080	140.130	138.420	140.390	101.580	105.000	107.170	105.010	107.000
79	140.990	139.970	138.310	141.240	100.050	104.080	107.160	104.900	106.950
80	137.640	138.820	137.110	139.540	99.850	103.610	107.320	104.970	107.020
81	135.110	136.770	134.910	136.470	99.950	104.110	107.530	105.290	107.220
82	134.420	141.430	141.720	134.210	102.350	102.750	106.240	103.990	106.040

- 119 -

channel number	51 2nd stg noz inl chamber press psig	54 2nd stg noz inl press hub # 3 psig	60 2nd stg noz inl press tip # 3 psig	63 2nd stg noz inl noz # 2 psig	66 2nd stg noz exit press hub # 3 psig	75 2nd stg noz exit press tip # 6 psig	76 2nd stg noz exit noz # 2 psig	77 2nd stg noz exit chamber press psig	78 exhaust manifold average psig
83	141.850	148.680	148.360	141.520	116.200	116.320	119.240	116.990	118.890
84	142.200	145.160	143.110	143.360	112.190	115.740	118.830	116.620	118.430
85	145.250	146.290	144.960	146.380	114.500	117.960	121.050	118.720	120.590
86	147.780	148.500	146.580	148.890	114.620	118.650	120.820	118.530	120.420
87	150.040	148.350	146.690	148.250	116.040	118.910	120.600	118.500	120.310
88	166.970	166.190	165.200	165.230	148.900	150.540	150.940	148.750	150.260
89	166.090	166.400	165.300	165.860	147.820	149.820	150.970	148.750	150.250
90	163.890	165.040	164.350	164.720	147.670	149.660	150.900	148.620	150.160
91	162.750	164.180	163.150	163.300	147.790	150.040	151.180	148.980	150.460
92	162.240	167.160	166.520	161.580	149.340	149.340	150.770	148.600	150.120
93	147.200	148.190	149.070	148.080	124.640	128.570	120.470	118.400	120.930
94	146.780	148.260	149.700	147.350	124.710	128.090	120.470	118.260	120.910
95	148.390	149.140	151.440	149.750	125.870	127.760	120.760	118.620	121.210
96	148.840	148.470	149.440	149.950	124.340	128.490	120.520	118.670	121.100
97	148.050	146.370	148.740	149.540	125.630	127.560	121.110	119.110	121.290
98	148.070	146.560	149.040	149.700	125.930	127.800	121.240	119.230	121.430
99	147.930	146.410	148.810	149.510	125.760	127.650	121.140	119.140	121.330
100	165.420	165.430	168.930	167.480	156.080	156.850	151.500	149.280	151.470
101	165.290	165.200	168.510	166.700	155.860	157.090	151.540	149.390	151.610
102	164.260	165.250	167.810	165.570	155.430	157.140	151.420	149.140	151.420
103	163.570	165.450	168.140	165.100	155.800	157.580	151.670	149.290	151.640
104	164.970	166.790	169.500	166.440	156.210	157.860	151.710	149.600	151.870
105	0.160	0.070	0.070	0.080	-0.150	-0.640	0.000	-0.710	0.230
106	0.160	0.070	0.070	0.080	-0.150	-0.640	0.000	-0.700	0.230
107	203.330	203.950	204.070	202.130	204.420	204.260	203.420	201.080	202.380

constant parameters		constant parameters			constant parameters			constant parameters			
a	b	c	d	e	f	g	h	i	j	k	l
specific heat ratio	gas R (nitrogen) lbf-ft/lbm-f	atm pr psia	flow nozzle inlet dia (inch)	effective flow nozzle throat dia (inch)	turbine mean dia (inch)	mach no due to area ratio	tot to sta pressure ratio due to area ratio	critical flow parameter gamma	effective area of flow nozzle throat (in.sq.)	1st stage nozzle flow area (in.sq.)	2nd stage nozzle flow area (in.sq.)
=====	=====	=====	=====	=====	=====	=====	=====	=====	=====	=====	=====
1.4040	55.1644	14.3552	0.8700	0.1578	3.0000	0.0190	1.0003	0.8121	0.0196	2.6851	3.2924
turbine seal leakage lbm/sec											
=====											
0.018											

- 1 2 1 -

channel number	1	2	3 new sonic nozzle	4 inlet manifold temperature	5 exhaust manifold temp	6 nozzle position degree	7 old sonic nozzle temp deg f	21 sonic noz u/s press psig	22 sonic noz thrt press psig	23 inlet manifold avg press psig	26 1st stg noz inl press hub # 3 psig
slice number	speed rpm	shaft torque in-lbf	temp deg f	temperature deg F	temp deg f	degree	temp deg f	psig	psig	psig	psig
=====	=====	=====	=====	=====	=====	=====	=====	=====	=====	=====	=====
1	0.0	0.020	72.200	73.240	76.690	0	76.090	0.000	0.000	0.000	0.000
2	35001.5	340.630	72.310	73.330	76.710	0	76.020	0.000	0.000	0.000	0.000
3	8.7	0.640	72.860	73.750	74.250	0	73.660	191.840	192.380	191.880	191.660
4	21166.1	1.660	70.630	77.400	13.260	0	42.370	214.220	201.810	200.680	196.420
5	21101.1	2.680	74.300	78.200	8.470	6	44.240	452.120	201.620	200.490	196.240
6	21118.4	4.010	74.140	76.000	3.790	6	37.280	451.890	200.940	199.790	195.540
7	21144.5	4.260	73.370	75.830	3.310	16	38.250	451.820	200.450	199.310	195.040
8	21138.0	4.050	73.900	75.790	3.500	26	37.140	452.020	200.970	199.830	195.580
9	21166.1	4.070	73.970	75.760	3.530	36	37.410	452.230	201.900	200.730	196.500
10	21164.0	3.900	73.600	75.580	3.570	-4	36.570	452.420	201.740	200.620	196.370
11	21177.0	3.500	74.330	75.440	5.180	-14	36.500	452.810	202.580	201.460	197.220
12	21049.1	3.590	73.420	75.390	5.750	-24	37.610	452.900	203.210	202.070	197.850
13	21094.6	5.900	73.690	75.440	-2.730	-24	36.860	465.690	202.390	201.220	196.780
14	21094.6	6.180	73.720	75.440	-3.740	-4	36.280	466.580	202.370	201.190	196.720
15	21072.9	6.780	73.860	75.360	-5.550	6	36.690	467.560	202.180	201.010	196.500
16	21103.3	7.110	73.790	75.320	-6.670	16	36.570	468.050	201.860	200.650	196.150
17	21077.2	6.990	73.970	75.200	-6.670	36	37.050	468.240	202.440	201.280	196.800
18	21025.2	2.800	74.000	75.430	10.160	36	35.760	434.190	201.680	200.570	196.640
19	21016.5	2.920	74.190	75.560	10.290	16	35.690	434.340	200.840	199.710	195.800
20	21031.7	2.790	74.670	75.620	10.890	6	36.030	434.230	200.620	199.520	195.590
21	21033.9	2.370	74.610	75.720	12.370	-4	36.180	434.340	201.750	200.650	196.780
22	21051.2	1.900	73.720	75.700	14.580	-24	36.480	433.770	202.550	201.450	197.550
23	21051.2	-1.570	74.280	76.040	34.210	6	36.030	363.970	201.340	200.440	197.720
24	21042.6	-1.630	74.390	76.180	35.940	16	36.550	363.840	201.660	200.730	198.040
25	21064.2	-1.550	74.320	76.460	37.450	36	36.660	363.660	201.920	201.030	198.350
26	21075.1	-1.580	74.610	76.800	39.070	-4	37.780	363.170	201.550	200.650	197.970
27	21079.4	-1.610	74.180	77.050	40.610	-24	37.480	363.790	202.660	201.720	199.080
28	15047.4	1.680	74.250	77.170	27.800	-24	40.610	362.260	199.360	198.410	195.750
29	15040.9	1.640	74.420	77.360	27.560	-4	40.280	362.210	199.020	198.120	195.400
30	15045.3	1.820	74.420	77.380	27.170	6	41.340	361.780	198.410	197.470	194.790
31	15038.8	1.850	74.670	77.450	26.900	16	41.420	360.550	197.290	196.370	193.680
32	15040.9	1.760	74.940	77.520	27.150	36	41.640	367.220	200.720	199.770	196.990
33	15010.6	7.030	75.120	77.330	11.990	36	44.020	443.980	203.540	202.410	198.390
34	15008.4	6.910	75.100	77.260	11.620	16	44.910	443.540	202.850	201.720	197.700
35	15004.1	6.760	74.940	77.260	11.440	6	45.790	443.870	203.650	202.540	198.490
36	14995.4	6.310	75.350	77.200	12.000	-4	45.130	444.220	204.740	203.640	199.620
37	14999.7	5.900	74.960	77.120	13.190	-24	45.790	444.660	206.130	205.030	201.030
38	15090.8	7.930	74.700	77.050	6.300	-24	45.520	453.700	201.350	200.190	195.940
39	15082.1	8.130	74.600	76.960	5.670	-4	45.320	453.420	201.150	200.010	195.790
40	15088.6	8.540	74.940	77.050	4.610	6	45.680	452.900	200.270	199.120	194.880
41	15088.6	8.960	74.770	77.010	3.590	16	45.610	452.240	199.280	198.140	193.870

channel number	1	2	3 new sonic nozzle	4 inlet manifold temperature deg F	5 exhaust manifold temp deg f	6 nozzle position degree	7 old sonic nozzle temp deg f	21 sonic noz u/s press psig	22 sonic noz thrt press psig	23 inlet manifold avg press psig	26 1st stg noz inl press hub # 3 psig
slice number	speed rpm	shaft torque in-lbf	temp deg f	temperature deg F	temp deg f	degree	temp deg f	psig	psig	psig	psig
42	15064.8	8.750	74.790	76.910	4.340	36	44.610	451.760	199.450	198.340	194.090
43	15053.9	11.670	74.840	76.770	-4.040	36	44.930	475.240	204.040	202.790	198.230
44	15069.1	12.160	75.190	76.770	-6.620	16	44.580	475.610	203.710	202.520	197.930
45	15045.3	11.530	75.050	76.700	-6.300	6	42.760	475.830	204.480	203.300	198.710
46	15027.9	11.410	74.390	76.460	-5.010	-4	43.220	476.210	205.420	204.210	199.640
47	15021.4	9.850	74.650	76.390	-3.370	-24	43.030	476.580	206.040	204.900	200.310
48	25066.8	3.390	74.630	76.630	10.470	-24	41.210	457.740	199.590	198.430	194.080
49	25068.9	4.100	74.790	76.800	9.220	-4	41.370	457.630	198.980	197.810	193.440
50	25086.3	4.940	74.720	77.100	7.450	6	41.000	457.620	198.320	197.160	192.810
51	25081.9	5.250	74.470	77.150	6.440	17	41.390	457.810	198.070	196.910	192.530
52	25086.3	5.140	74.530	77.200	7.060	36	40.980	457.840	199.210	198.000	193.640
53	10099.6	17.450	74.600	77.000	-5.990	36	43.740	466.090	199.220	198.020	193.550
54	10114.7	16.830	74.600	76.590	-6.930	16	43.780	466.710	199.620	198.410	193.920
55	10119.1	15.970	74.890	76.450	-5.360	6	43.440	467.200	200.700	199.510	195.000
56	10134.3	14.950	75.080	76.190	-4.550	-4	43.240	467.650	201.580	200.400	195.920
57	10142.9	14.740	74.700	75.630	-4.070	-24	43.220	467.430	201.340	200.140	195.690
58	10129.9	12.040	74.120	75.300	-0.450	-24	42.490	457.440	201.830	200.680	196.380
59	10121.2	12.110	74.770	75.040	-0.960	-4	42.170	457.640	202.210	201.070	196.810
60	10119.1	12.490	74.930	75.160	-2.080	6	42.330	457.620	201.800	200.620	196.370
61	10132.1	12.990	74.890	74.780	-3.020	16	42.640	458.100	201.000	199.830	195.550
62	10160.3	13.000	74.600	74.710	-2.910	36	42.030	457.940	200.460	199.310	194.980
63	10004.2	10.560	74.600	74.540	1.080	36	41.710	446.170	202.470	201.360	197.280
64	10019.3	10.350	74.910	74.500	0.360	16	40.820	446.290	202.430	201.250	197.210
65	10025.8	9.830	74.860	74.220	1.300	6	41.020	446.580	203.650	202.520	198.510
66	10006.3	9.280	74.860	74.310	2.320	-4	41.090	446.720	204.680	203.550	199.530
67	9995.5	8.870	74.740	74.060	3.330	-24	40.190	442.380	202.810	201.670	197.670
68	10069.2	2.930	74.770	74.050	15.020	-24	38.430	371.920	201.800	200.850	198.040
69	10067.0	3.060	74.470	74.120	14.710	-4	38.300	373.870	202.920	202.000	199.150
70	10060.5	3.420	74.700	73.990	14.000	6	38.460	373.730	201.780	200.830	197.990
71	10058.4	3.530	74.770	73.980	13.890	16	38.180	374.280	201.830	200.900	198.050
72	10056.2	3.470	74.750	73.890	14.220	36	37.960	374.690	202.330	201.370	198.580
73	676.5	27.230	74.470	72.280	16.450	36	40.800	479.820	203.040	201.830	197.140
74	724.2	25.260	74.110	71.910	16.400	16	40.910	480.050	204.590	203.430	198.780
75	693.8	24.320	74.210	71.630	16.400	6	40.890	480.360	205.120	203.920	199.270
76	657.0	23.390	73.910	71.340	16.440	-4	40.850	475.600	203.090	201.890	197.290
77	741.5	23.150	74.230	70.880	16.200	-24	40.930	475.700	203.390	202.190	197.620
78	667.8	19.740	74.790	70.570	17.110	-24	41.160	461.670	202.770	201.610	197.240
79	648.3	19.760	74.560	70.170	16.930	-4	41.030	461.910	202.850	201.710	197.370
80	739.4	19.880	74.860	70.170	16.850	6	40.870	461.860	202.640	201.470	197.140
81	698.2	20.570	74.740	69.820	16.530	16	40.680	461.890	201.830	200.630	196.250
82	823.9	22.340	74.420	69.520	16.160	36	40.550	461.800	199.540	198.360	193.950

- 123 -

channel number	1	2	3 new sonic nozzle	4 inlet manifold temperature	5 exhaust manifold temp	6 nozzle position degree	7 old sonic nozzle temp deg f	21 sonic noz u/s press psig	22 sonic noz thrt press psig	23 inlet manifold avg press psig	26 1st stg noz inl press hub # 3 psig
slice number	speed rpm	shaft torque in-lbf	temp deg f	temperature deg F	temp deg f	degree	temp deg f	press psig	press psig	psig	psig
=====	=====	=====	=====	=====	=====	=====	=====	=====	=====	=====	=====
83	782.7	19.340	74.670	69.570	16.930	36	40.770	448.140	200.160	199.040	194.900
84	715.5	17.800	74.420	69.110	17.250	16	40.840	447.920	202.350	201.210	197.130
85	691.7	17.300	75.010	69.220	17.290	6	40.890	448.040	202.850	201.740	197.640
86	813.1	16.760	74.860	68.780	17.420	-4	40.910	447.980	203.130	202.000	197.950
87	689.5	16.710	74.610	68.870	17.360	-24	41.020	448.160	203.800	202.660	198.630
88	787.1	10.050	74.790	68.400	19.590	-24	39.280	382.770	202.140	201.150	198.160
89	665.6	10.080	74.770	68.360	20.190	-4	39.000	382.990	202.330	201.390	198.360
90	691.7	10.230	74.770	68.410	20.150	6	39.040	383.180	202.360	201.390	198.380
91	728.5	10.690	74.670	68.590	20.020	16	39.040	382.980	201.980	200.990	197.990
92	659.1	11.560	74.750	68.310	19.810	36	39.020	382.580	200.060	199.110	196.050
93	25006.1	-1.110	74.440	69.660	12.060	36	37.390	450.750	202.210	201.100	196.920
94	24915.0	0.260	74.630	70.530	10.890	6	36.480	451.410	201.300	200.170	196.000
95	0.0	2.060	73.790	70.940	10.840	0	43.440	0.230	-0.070	-0.070	0.000
96	0.0	1.600	73.270	72.440	28.930	0	48.800	207.590	205.940	205.480	205.310
97	0.0	239.310	74.400	72.420	27.040	0	51.180	0.230	0.050	0.000	0.010
98	0.0	1.380	74.120	72.440	34.480	0	52.240	0.160	0.030	0.000	0.000
99	24470.5	341.090	74.210	72.260	39.130	0	53.090	0.160	0.000	0.000	0.000
100	34932.2	341.100	74.320	72.300	41.520	0	53.410	0.160	0.020	0.000	0.000

NASA CR-179548
R/RD 86-214

channel number	29	32	36	37	40	43	48	50	51	54	60
	1st stg noz inl press hub # 6	1st stg noz inl press tip # 3	1st stg noz inl noz # 1	1st stg noz inl noz # 2	1st stg noz exit press hub # 3	1st stg noz exit press hub # 6	1st stg noz exit press tip # 6	1st stg noz exit	2nd stg noz inl chamber press	2nd stg noz inl press hub # 3	2nd stg noz inl press tip # 3
slice number	psig	psig	psig	psig	psig	psig	psig	psig	psig	psig	psig
1	0.000	-0.020	0.030	0.000	0.000	0.000	0.000	0.000	0.000	0.000	0.010
2	0.000	-0.020	0.010	0.000	0.000	0.000	0.000	0.000	0.000	0.000	0.010
3	192.220	191.420	191.170	192.890	191.340	191.580	189.890	190.580	189.790	190.330	190.380
4	197.680	194.910	199.930	201.810	127.890	133.660	138.040	128.380	127.420	127.950	128.410
5	197.490	194.710	199.800	201.490	126.280	132.010	136.680	127.050	126.190	127.560	128.120
6	196.750	194.010	199.070	200.780	125.010	130.940	135.560	125.780	124.960	126.300	126.850
7	196.270	193.510	198.590	200.330	124.190	130.120	134.700	125.560	124.540	125.570	127.050
8	196.790	194.020	199.000	200.840	125.220	131.020	135.650	127.360	125.740	125.290	127.570
9	197.700	194.930	199.850	201.710	127.240	132.650	137.170	129.690	128.400	127.600	129.510
10	197.610	194.800	199.750	201.610	126.330	132.260	136.900	126.810	125.960	126.230	126.720
11	198.440	195.650	200.570	202.420	127.690	133.520	138.110	127.540	127.200	126.130	126.540
12	199.100	196.290	201.210	203.040	128.850	134.600	139.240	128.170	128.330	126.490	127.400
13	198.030	195.150	200.360	202.240	118.260	125.150	130.000	117.560	117.990	115.500	116.210
14	198.000	195.080	200.460	202.230	117.370	124.510	129.380	117.580	117.310	116.360	116.050
15	197.750	194.860	200.230	202.010	116.060	123.230	128.130	116.690	116.130	117.380	116.880
16	197.430	194.540	199.990	201.730	114.910	122.260	127.030	116.180	115.470	116.620	117.640
17	198.040	195.150	200.470	202.300	116.900	123.730	128.500	119.470	118.270	117.320	118.500
18	197.830	195.190	199.740	201.570	136.560	141.140	145.470	138.770	137.440	136.550	138.670
19	196.980	194.310	199.010	200.760	134.730	139.800	144.160	136.410	134.820	135.320	137.460
20	196.770	194.120	198.810	200.570	134.360	139.470	143.860	135.350	134.190	135.640	137.190
21	197.960	195.260	199.820	201.670	136.280	141.190	145.660	136.680	135.570	136.280	137.460
22	198.720	196.060	200.560	202.440	137.790	142.510	146.960	137.060	136.730	135.040	136.770
23	198.730	196.590	199.660	201.400	161.920	165.200	168.510	162.190	160.790	161.810	163.860
24	199.070	196.980	199.980	201.730	162.420	165.560	168.800	163.080	161.680	162.380	164.250
25	199.410	197.280	200.250	202.040	163.110	165.690	169.100	164.120	162.580	162.480	164.320
26	198.980	196.830	199.850	201.610	162.300	165.510	168.800	162.320	160.880	161.730	163.990
27	200.110	197.980	200.940	202.690	163.760	166.580	169.900	162.880	161.670	161.440	164.320
28	196.750	194.640	197.760	199.500	160.810	163.360	165.700	160.540	160.010	159.500	160.190
29	196.400	194.300	197.400	199.160	160.340	162.910	165.250	160.640	159.680	160.170	160.710
30	195.760	193.670	196.750	198.520	159.570	162.120	164.490	160.080	159.110	160.270	161.020
31	194.690	192.520	195.640	197.420	158.270	160.760	163.130	159.020	157.960	158.820	159.850
32	197.980	195.860	199.020	200.710	161.140	163.540	165.890	162.480	161.380	161.270	162.390
33	199.600	196.850	201.650	203.410	136.200	140.560	144.060	138.560	137.830	136.180	137.680
34	198.910	196.130	201.000	202.730	135.080	139.540	143.140	136.580	136.220	137.000	137.470
35	199.710	196.930	201.700	203.510	136.130	140.590	144.220	137.290	136.870	138.830	137.760
36	200.820	198.080	202.800	204.640	137.910	142.270	145.850	138.880	138.690	138.840	137.490
37	202.240	199.490	204.160	205.990	139.990	144.350	147.970	140.430	140.980	138.680	138.810
38	197.180	194.330	199.430	201.230	126.150	131.300	135.240	126.890	127.660	124.750	124.920
39	197.030	194.160	199.340	201.080	125.940	131.140	135.050	127.000	127.150	126.050	124.540
40	196.120	193.280	198.490	200.220	124.430	129.730	133.660	125.610	125.510	126.490	124.920
41	195.100	192.250	197.480	199.210	122.660	128.070	132.010	124.070	123.930	126.080	125.010

- 1 2 5 -

channel number	29 1st stg noz inl press hub # 6 psig	32 1st stg noz inl press tip # 3 psig	36 1st stg noz inl noz # 1 psig	37 1st stg noz inl noz # 2 psig	40 1st stg noz exit press hub # 3 psig	43 1st stg noz exit press hub # 6 psig	48 1st stg noz exit press tip # 6 psig	50 1st stg noz exit noz # 2 psig	51 2nd stg noz inl chamber press psig	54 2nd stg noz inl press hub # 3 psig	60 2nd stg noz inl press tip # 3 psig
42	195.280	192.470	197.530	199.410	123.680	128.940	132.730	126.210	125.680	123.460	125.030
43	199.510	196.540	201.980	203.810	115.540	122.290	126.510	117.980	117.680	115.420	116.160
44	199.200	196.200	201.770	203.540	114.060	121.130	125.400	115.370	115.380	117.040	115.980
45	200.000	197.020	202.490	204.310	115.920	122.840	127.190	117.030	117.030	118.970	116.980
46	200.910	197.920	203.380	205.220	118.160	124.810	129.070	119.390	119.510	118.830	116.600
47	201.590	198.610	204.010	205.840	119.560	126.110	130.450	120.450	121.390	117.930	118.090
48	195.320	192.410	197.600	199.470	117.300	124.110	129.600	115.880	115.830	113.150	115.480
49	194.680	191.760	197.160	198.900	115.900	122.930	128.360	115.720	114.660	114.080	115.470
50	194.030	191.120	196.480	198.250	114.280	121.530	126.930	114.660	113.470	114.830	116.290
51	193.750	190.870	196.220	198.000	113.490	120.810	126.210	114.720	113.220	114.140	116.410
52	194.890	191.980	197.190	199.070	116.690	123.180	128.730	119.050	117.590	116.300	118.910
53	194.750	191.860	197.190	199.070	111.280	117.890	121.650	113.580	113.270	112.400	112.310
54	195.150	192.200	197.590	199.470	111.670	118.370	122.180	113.640	113.140	117.980	115.270
55	196.260	193.330	198.670	200.540	114.390	120.760	124.470	116.410	115.540	116.380	114.190
56	197.150	194.230	199.550	201.420	116.650	122.640	126.080	118.620	118.080	116.910	114.560
57	196.940	193.980	199.440	201.220	116.310	122.500	125.980	118.020	118.630	115.890	114.880
58	197.630	194.760	199.990	201.730	125.440	130.730	133.830	127.270	127.680	125.190	124.620
59	198.020	195.150	200.290	202.100	126.130	131.230	134.390	128.160	127.850	126.070	124.090
60	197.600	194.720	199.980	201.700	125.160	130.350	133.710	127.380	126.720	127.510	124.590
61	196.750	193.880	199.170	200.920	122.940	128.370	131.810	125.240	124.650	128.350	125.280
62	196.190	193.340	198.510	200.370	122.040	127.410	130.820	124.710	124.350	123.550	123.960
63	198.490	195.710	200.670	202.410	133.680	138.080	141.020	136.220	135.850	135.010	135.280
64	198.430	195.660	200.430	202.330	133.350	137.830	140.870	135.430	135.050	138.040	136.650
65	199.690	196.900	201.690	203.560	135.440	139.820	142.810	137.460	136.880	138.450	136.330
66	200.740	197.960	202.700	204.550	137.140	141.460	144.430	139.190	138.660	138.330	136.080
67	198.890	196.140	200.980	202.700	136.030	140.470	143.340	137.730	137.920	135.760	135.460
68	199.050	196.850	200.110	201.890	161.640	163.870	165.780	162.230	162.190	160.980	161.070
69	200.190	198.030	201.270	203.050	162.890	165.120	167.040	163.640	163.280	163.100	162.220
70	199.000	196.770	200.040	201.860	160.940	163.240	165.110	161.740	161.310	162.330	161.370
71	199.080	196.850	200.140	201.960	160.950	163.230	165.160	161.840	161.350	162.820	162.480
72	199.570	197.350	200.650	202.450	161.630	163.890	165.710	163.100	162.470	161.550	162.370
73	198.440	195.390	201.070	202.850	107.300	114.990	118.840	110.430	109.550	111.330	113.830
74	200.070	197.030	202.600	204.420	112.670	120.260	123.950	115.710	113.590	116.130	115.520
75	200.590	197.500	203.060	204.920	114.160	121.560	124.840	117.730	115.870	118.570	115.580
76	198.580	195.540	201.210	202.940	114.070	120.400	123.650	117.410	115.920	116.610	115.420
77	198.890	195.870	201.470	203.230	114.360	121.160	124.420	117.290	117.240	114.280	113.010
78	198.500	195.600	200.900	202.670	125.300	130.590	133.170	128.290	128.130	125.460	124.670
79	198.590	195.660	201.010	202.810	125.630	130.660	133.190	129.230	127.680	128.320	126.780
80	198.350	195.480	200.810	202.560	125.020	129.960	132.660	128.510	126.680	128.240	126.790
81	197.500	194.600	199.930	201.730	122.940	128.230	130.980	126.180	124.040	126.880	124.850
82	195.180	192.240	197.690	199.500	117.510	123.180	126.110	121.430	120.440	119.590	124.590

NASA CR-179548
R/RD 86-214

channel number	29 1st stg noz inl press slice hub # 6 psig	32 1st stg noz inl press tip # 3 psig	36 1st stg noz inl noz # 1 psig	37 1st stg noz inl noz # 2 psig	40 1st stg noz exit press hub # 3 psig	43 1st stg noz exit press hub # 6 psig	48 1st stg noz exit press tip # 6 psig	50 1st stg noz exit noz # 2 psig	51 2nd stg noz inl chamber press psig	54 2nd stg noz inl press hub # 3 psig	60 2nd stg noz inl press tip # 3 psig
83	196.100	193.290	198.280	200.160	128.970	133.480	135.900	132.720	131.790	128.550	135.960
84	198.350	195.520	200.390	202.300	133.350	137.580	139.830	136.280	134.130	136.440	135.180
85	198.840	196.040	200.860	202.800	133.990	138.640	140.760	137.330	135.480	138.090	135.770
86	199.140	196.350	201.170	203.090	135.110	138.980	141.110	138.320	136.780	137.760	136.930
87	199.820	197.010	201.960	203.760	135.900	140.170	142.290	138.690	138.440	136.160	135.670
88	199.200	196.900	200.470	202.180	159.130	161.480	162.430	160.940	160.440	159.160	159.040
89	199.450	197.130	200.610	202.400	159.490	161.720	162.540	161.640	160.260	160.560	160.140
90	199.420	197.140	200.680	202.410	159.450	161.490	162.450	161.480	159.720	161.350	160.540
91	199.010	196.730	200.330	202.020	158.780	161.050	162.110	160.700	158.850	160.700	159.780
92	197.070	194.760	198.370	200.140	156.290	158.560	159.620	158.680	157.740	151.880	160.960
93	198.150	195.290	200.250	202.150	128.260	133.710	139.230	130.430	128.810	127.660	130.510
94	197.230	194.350	199.470	201.290	125.490	131.840	137.280	126.140	124.620	126.280	128.550
95	0.000	-0.160	0.150	-0.130	-0.070	-0.050	-0.070	0.000	0.170	0.000	0.000
96	205.870	204.930	204.720	206.390	205.020	205.250	203.580	204.230	203.410	203.970	204.000
97	0.020	-0.160	0.150	-0.140	0.000	-0.050	-0.010	0.010	0.240	0.000	0.010
98	0.050	-0.160	0.150	-0.070	-0.010	-0.030	-0.010	0.050	0.240	0.000	0.010
99	0.020	-0.160	0.150	-0.070	-0.010	-0.010	0.000	0.060	0.220	0.000	0.000
100	0.020	-0.160	0.100	-0.070	-0.010	-0.020	0.000	0.080	0.170	0.000	0.000

- 1 2 7 -

channel number	63	66	72	75	76	77	78
	2nd stg noz inl	2nd stg noz exit press	2nd stg noz exit press	2nd stg noz exit press	2nd stg noz exit noz # 2	2nd stg noz exit chamber press	exhaust manifold average
slice number	noz # 2 psig	hub # 3 psig	tip # 3 psig	tip # 6 psig	psig	psig	psig
	=====	=====	=====	=====	=====	=====	=====
1	0.000	0.000	-0.020	0.000	0.010	0.000	0.100
2	0.000	0.000	-0.240	0.000	0.000	0.000	0.080
3	188.450	190.610	193.650	191.230	189.790	188.510	188.770
4	127.720	108.860	112.740	112.680	109.630	108.410	109.600
5	126.280	107.280	110.700	110.650	108.090	106.620	107.860
6	125.000	105.900	110.020	109.210	106.750	105.240	106.560
7	124.490	106.880	109.960	109.220	106.820	105.220	106.590
8	126.060	108.130	110.310	109.650	107.200	105.600	106.960
9	128.380	106.370	110.380	109.490	107.160	105.650	106.950
10	126.190	106.110	110.180	110.000	107.260	105.830	107.080
11	127.350	106.270	110.370	110.310	107.430	106.000	107.250
12	128.440	106.700	110.560	110.750	107.950	106.470	107.710
13	118.040	90.710	95.420	94.660	92.690	91.210	92.540
14	117.320	90.940	95.680	95.160	92.900	91.470	92.920
15	116.020	91.330	95.930	95.130	93.230	91.740	93.220
16	115.230	92.710	96.050	95.180	93.430	91.830	93.330
17	118.240	92.000	96.050	94.640	93.020	91.520	92.960
18	137.390	119.620	123.080	122.470	119.550	117.930	119.350
19	135.100	121.150	123.430	123.220	120.300	118.530	119.980
20	134.320	120.430	123.160	123.130	120.130	118.370	119.880
21	135.860	120.660	123.170	124.080	120.960	119.310	120.750
22	137.040	120.500	123.040	124.100	120.820	119.200	120.550
23	160.830	154.990	155.610	157.460	153.380	151.510	153.040
24	161.600	155.410	157.160	157.830	153.870	151.990	153.470
25	162.510	155.430	156.900	157.700	153.690	151.900	153.380
26	161.040	155.300	156.710	157.780	153.670	151.830	153.350
27	162.040	155.790	156.980	158.280	154.300	152.420	153.840
28	159.610	152.070	153.760	154.410	151.860	150.170	151.160
29	159.320	152.320	153.650	154.580	152.030	150.320	151.380
30	158.650	152.360	153.510	154.340	151.950	150.200	151.300
31	157.430	151.520	153.240	153.140	150.760	149.000	150.100
32	160.840	152.400	153.920	154.460	152.060	150.430	151.440
33	137.220	121.570	122.820	122.990	121.390	119.890	120.990
34	135.360	121.320	123.280	123.380	121.640	120.100	121.240
35	136.200	120.390	123.270	123.490	121.870	120.360	121.490
36	137.960	120.560	123.420	124.280	122.250	120.770	121.900
37	140.110	121.940	124.110	124.910	123.280	121.760	122.820
38	127.270	104.430	107.510	107.450	106.360	104.870	106.060
39	126.830	104.280	107.520	107.880	106.450	105.030	106.300
40	124.710	104.010	107.460	107.920	106.360	104.870	106.140
41	123.090	104.630	107.050	107.140	106.350	104.850	106.120

Two Stage Partial Admission Turbine Test (NAS3-23773) Test No 10 : 1/4 DESIGN CONFIGURATION Test Date 17,Dec 1985

channel number	63	66	72	75	76	77	78
	2nd stg	2nd stg	2nd stg	2nd stg	2nd stg	2nd stg	exhaust manifold
	noz inl	noz exit	noz exit	noz exit	noz exit	noz exit	average
slice number	noz # 2	press hub # 3	press tip # 3	press tip # 6	noz # 2	chamber press	psig
	psig	psig	psig	psig	psig	psig	psig
=====	=====	=====	=====	=====	=====	=====	=====
42	125.030	106.190	107.520	107.830	106.530	105.120	106.290
43	116.950	93.400	96.010	95.130	94.170	92.800	94.050
44	114.460	91.660	94.590	94.030	94.020	92.610	93.890
45	116.180	90.790	94.430	94.600	93.820	92.440	93.720
46	119.150	91.020	94.880	95.090	94.230	92.830	94.160
47	120.610	92.520	95.670	95.800	95.180	93.740	95.040
48	116.520	91.720	95.270	95.860	92.650	91.200	92.810
49	115.390	91.730	95.260	95.850	92.650	91.170	92.920
50	114.050	92.180	95.340	95.590	92.690	91.080	92.880
51	113.760	93.150	95.840	95.470	92.730	91.080	92.880
52	117.910	92.400	96.050	95.490	92.690	91.190	92.930
53	112.600	90.890	92.060	93.300	93.030	91.550	92.770
54	112.630	91.230	91.860	92.510	93.160	91.620	92.850
55	115.400	89.400	92.890	93.160	93.250	91.720	92.960
56	117.860	91.080	93.410	93.710	93.850	92.350	93.610
57	118.280	90.930	93.310	93.720	93.890	92.370	93.680
58	127.100	104.490	105.580	107.080	106.830	105.300	106.460
59	127.290	105.010	106.890	107.470	107.040	105.470	106.690
60	126.320	104.290	107.060	107.550	107.220	105.600	106.830
61	124.210	104.630	107.090	107.340	107.200	105.590	106.750
62	123.530	105.650	106.630	107.860	106.880	105.290	106.480
63	134.920	120.140	120.450	121.860	120.780	119.110	120.210
64	134.300	120.630	119.720	121.040	121.260	119.580	120.670
65	136.510	118.870	121.010	122.160	121.420	119.740	120.910
66	138.040	119.670	121.660	122.310	121.620	119.970	121.130
67	137.180	118.890	120.590	121.230	120.660	118.980	120.130
68	161.400	152.080	152.670	153.930	152.680	150.890	151.840
69	162.510	153.370	154.130	155.560	154.140	152.330	153.340
70	160.230	151.880	153.800	154.260	152.780	150.970	152.010
71	160.300	153.200	153.640	154.780	153.750	151.910	152.920
72	161.420	153.930	154.330	155.070	153.730	151.920	152.900
73	109.110	90.420	90.330	90.120	92.540	90.910	92.180
74	114.160	89.450	90.310	91.680	93.460	91.790	92.970
75	116.250	88.650	90.570	91.680	93.510	91.800	93.050
76	115.760	88.690	90.270	90.450	92.350	90.650	91.940
77	116.310	89.510	89.880	90.690	92.270	90.630	91.900
78	127.070	106.420	106.640	107.260	108.360	106.620	107.830
79	127.440	107.280	106.640	107.470	109.020	107.240	108.480
80	126.990	105.550	106.610	108.150	109.150	107.300	108.590
81	124.570	104.110	106.270	106.290	107.790	105.960	107.220
82	119.980	106.260	105.100	105.320	107.220	105.400	106.680

- 1 2 9 -

channel number	63 2nd stg noz inl noz # 2 psig	66 2nd stg noz exit press hub # 3 psig	72 2nd stg noz exit press tip # 3 psig	75 2nd stg noz exit press tip # 6 psig	76 2nd stg noz exit noz # 2 psig	77 2nd stg noz exit chamber press psig	78 exhaust manifold average psig
83	131.250	120.720	117.380	119.610	121.090	119.210	120.410
84	134.540	118.310	119.340	120.140	121.350	119.450	120.630
85	135.670	118.250	119.530	120.650	121.480	119.560	120.760
86	136.500	119.400	119.700	120.770	121.590	119.670	120.910
87	137.320	120.660	120.340	121.290	121.980	120.130	121.290
88	159.160	150.710	148.840	151.100	151.200	149.230	150.240
89	159.620	151.410	150.360	151.640	151.770	149.800	150.830
90	159.580	150.430	150.810	152.290	152.080	150.060	151.100
91	158.760	150.450	151.030	151.740	152.040	150.050	151.060
92	156.890	153.000	150.970	151.660	152.090	150.100	151.150
93	129.230	108.320	114.600	111.300	107.700	105.950	108.020
94	125.390	108.390	111.400	111.290	107.720	105.810	107.910
95	-0.080	-0.150	57.990	-0.640	0.120	-0.750	0.340
96	201.970	204.180	199.480	203.940	203.580	201.030	202.470
97	-0.070	-0.150	128.950	-1.050	0.060	-1.220	0.460
98	-0.050	-0.150	94.630	-1.120	0.060	-1.290	0.460
99	-0.030	-0.080	66.680	-1.120	0.060	-1.360	0.460
100	-0.020	-0.080	49.280	-1.120	0.090	-1.380	0.460

NASA CR-179548
R/R/D 86-214

APPENDIX C Data Reduction Technique

The following describes the equations and methods used to determine the overall turbine performance. All the pressures and temperatures are absolute values.

Many of the properties equation were obtained by curve fitting real property data. The real property data were obtained from running a nitrogen property routine, ONTHPR, which was written, in Rocketdyne's main-frame UNIVAC computer, by J. K. Jakobsen in 1972. The program is located in the Engineering Subroutine Library.

The curvefit equations used will be included in this section, along with their coefficients. The curvefits are only valid for the range of test operation. A discussion of how the curvefits coefficients were calculated will be discussed at the end of this section.

The flowrates were obtained by using the ideal isentropic critical flow equation across a nozzle. The specific heat ratio (γ) used in the equation has obtained by a curvefit equation that characterized the real property γ as a function of temperature and pressure.

$$\dot{m} = g A M P_0 \left[\frac{\gamma}{g R T_0} \right]^{\frac{1}{2}} \cdot \left[1 + \frac{\gamma - 1}{2} M^2 \right]^{\frac{-(\gamma+1)}{2(\gamma-1)}}$$

- where :
- P0 = Total Pressure, psia
 - T0 = Total Temperature, deg R
 - M = Mach number
 - A = nozzle throat area, in²
 - R = gas constant, ft-lbf/lbm-deg R
 - g = 32.174 lbm-ft/lbf-sec²
 - \dot{m} = flowrate, lbm/sec
 - γ = specific heat ratio

The total pressure and temperature were obtained by iterating between the Mach number at the nozzle inlet, due to the mass flowrate. The mass flowrate was calculated, by the above equation, where $M = 1$. The total pressure was initially assumed to equal the static pressure measured. Using this initial assumption a Mach number at the nozzle inlet was calculated. A new total pressure was then calculated. This process was repeated about 3 times before no further change occurred.

The nozzle inlet Mach number was calculated by dividing the mass flow by the inlet area and sonic velocity. The total pressure and temperature were calculated by the following equations

$$P_0 := P \left[1 + \frac{\gamma - 1}{2} M_{inlet}^2 \right]^{\frac{\gamma}{\gamma - 1}} \quad T_0 := T \left[1 + \frac{\gamma - 1}{2} M_{inlet}^2 \right]$$

Where T and P are the nozzle inlet static temperature and pressure.

The equation for gamma is : where k0 ≡ 1 ..9

i := 1 ..3 j := 1 ..3

C ≡
k0

$$\gamma := \sum_i \sum_j C_{3(i-1)+j} \cdot \frac{P^{i-1}}{T^{j-1}}$$

0
1.38718101309 10
1
1.33421229506 10
3
-3.36768173119 10
-5
7.24069630487 10
-1
-1.02536990231 10
1
6.55360232959 10
-7
2.40239920704 10
-4
-2.83856529863 10
-2
8.13424970141 10

The specific volume of the gas was calculated by the following curvefit equation :

i := 1 ..3 ;j := 1 ..3 where k0 ≡ 1 ..9

D ≡
k0

$$v := \sum_i \sum_j D_{3(i-1)+j} \cdot \frac{T^{i-1}}{P^{j-1}}$$

-2
-9.73934911339 10
-3
-5.387717631225 10
-2
-4.36782615969 10
-4
2.94268189908 10
-1
3.82360778543 10
-2
2.27130816879 10
-7
-2.25608326345 10
-7
9.8782949984 10
-5
-3.06153388554 10

The velocity, V, at the nozzle inlet was calculated by mass continuity equation :

$$V = 144 \cdot \frac{v}{\text{area}_{\text{inl}}} \quad \begin{array}{l} V = \text{inlet velocity, ft/sec} \\ \text{area} = \text{inlet area, in}^2 \\ v = \text{specific volume, ft}^3/\text{lb} \end{array}$$

The nozzle inlet Mach number :

$$M_{\text{inlet}} := \frac{V}{\sqrt{g \text{ gam } R T}}$$

The turbine pressure ratio across the turbine was assumed to be total-to-total since the two areas of measurement were relatively large, that is, the Mach number was less than 0.1.

$$P_r := \frac{P_{\text{in}}}{P_{\text{out}}}$$

The turbine efficiency was obtained by dividing the actual enthalpy, across the turbine, by the isentropic enthalpy.

$$\eta_{\text{turb}} := \frac{h_{\text{in_act}} - h_{\text{out_act}}}{h_{\text{in_act}} - h_{\text{out_isen}}}$$

Two curvefit equations were used for enthalpy. One as a function of temperature T and pressure P. The other as a function of pressure P and entropy s. A curvefit equation was used for entropy, as a function of pressure and temperature. The pressure and temperature measured at the inlet were use to obtain the turbine inlet enthalpy and entropy. The turbine outlet pressure and temperature measured were used to obtain the actual outlet enthalpy. The turbine outlet pressure and the inlet calculated entropy were used to obtain the turbine outlet isentropic enthalpy. The equations used are :

i := 1 ..4 j := 1 ..4

$$s := \sum_i \sum_j E_{4(i-1)+j} \cdot \frac{T}{P^{j-1}} \quad , \text{btu}/(\text{lbm} \cdot \text{deg R})$$

where : for k1 ≡ 1 ..4

E ≡
k1

6.7544752574 10	-1
6.4345893938 10	1
-3.23568313559 10	3
-1.66276892738 10	4

E ≡
k1+4

2.14457854498 10	-3
-5.35320318401 10	-3
-2.17601576899 10	1
1.82707334974 10	3

E ≡
k1+8

-2.40290241705 10	-6
-1.35426963699 10	-4
6.46831998357 10	-2
-4.67810491676 10	0

E ≡
k1+12

1.0863782209 10	-9
1.61878278367 10	-7
-5.38690472998 10	-5
3.6511832911 10	-3

i := 1 ..4 j := 1 ..4

$$h_{PT} := \sum_i \sum_j F_{4(i-1)+j} \cdot \frac{T}{P^{j-1}} \quad ; \text{btu}/\text{lbm}$$

where : for k2 ≡ 1 ..4

F ≡
k2

-5.22655244233 10	1
9.464278572589 10	3
-3.40829266077 10	5
-1.7935734637 10	7

F ≡
k2+4

4.11793038505 10	-1
-7.04911193625 10	0
-4.56884504042 10	3
4.07625294607 10	5

$$F \equiv k2+8$$

-1.69214857206 10	-4
-4.17603347662 10	-2
1.6882782708 10	1
-1.1773032577 10	3

$$F \equiv k2+12$$

4.75648465964 10	-8
5.24523782643 10	-5
-1.48071153388 10	-2
9.55472887408 10	-1

$$i := 1 \dots 3 \quad j := 1 \dots 6$$

$$h_{Ps} := \sum_i \sum_j G_{6(i-1)+j} \frac{s^{i-1}}{p^{j-1}}$$

where : for $k3 \equiv 1 \dots 6$

$$G \equiv k3$$

9.03482161609 10	2
7.7392940758 10	4
1.63942252554 10	7
-4.83895335393 10	9
3.27377498877 10	11
-3.052261796 10	12

$$G \equiv k3+6$$

-1.70554732153 10	3
-1.08062748155 10	5
-6.44250655923 10	6
2.69374376999 10	9
-5.40664991925 10	10
-1.01307802656 10	13

$$G \equiv k3+12$$

8.63431991984 10	2
1.14082068107 10	4
2.43746386678 10	6
-3.136026318 10	8
-6.60879065646 10	10
6.96976678636 10	12

The mean velocity to isentropic velocity ratio is :

$$\frac{U}{C_o} := \frac{\frac{D}{12} \cdot \pi \cdot \frac{N}{60}}{\sqrt{2 g J \left[h_{in_act} - h_{out_isen} \right]}}$$

where :

U = ft/sec

C_o = ft/sec

N = rmp

D = dia, inch

J = 778.17 ft*lb/btu

This parameter is the loading function of the turbine.

It is useful to convert the turbine performance to equivalent standard ambient state conditions. The following equations were used to obtain equivalent speed and flow.

$$m_{eq} := \frac{\dot{m} \sqrt{\frac{\theta}{cr}} \cdot \epsilon}{\delta} \quad ; \quad \text{lbfm/sec : (Equivalent flow)}$$

$$N_{eq} := \frac{N}{\sqrt{\frac{\theta}{cr}}} \quad ; \quad \text{rpm : (Equivalent Speed)}$$

where :

$$\frac{\theta}{cr} := \frac{2 \text{ gam } R T \quad z}{\text{Tot}^2} \\ (\text{gam} + 1) \cdot (1019.5)^2$$

$$\delta := \frac{P}{14.696} \quad \text{Tot} \quad \text{and}$$

$$\epsilon := \frac{0.7396}{\text{gam}} \\ \frac{\text{gam}}{\text{gam}-1} \\ \left[\frac{2}{\text{gam} + 1} \right]$$

The following discussion will be on curvefit coefficient determination. The curvefit equations were derived by intuitive interpretation of real property curve trends. If a dependent variable, such as specific volume, was a function of two independent variables, temperature and pressure, then the equation would be a matrix of these two variables. The matrix would be a cross product of two polynomial of the two independent variables. The polynomial power would be positive if the dependent variable increased with the independent variable and negative for the reverse.

To illustrate; specific volume increases with temperature and decreases with pressure, therefore, the equation would look like the following:

$$\text{vol} := \left[a_1 + a_2 T + a_3 T^2 \right] \cdot \left[b_1 + \frac{b_2}{P} + \frac{b_3}{P^2} \right]$$

or multiplying across and re-substituting new dummy coefficients the equation would be as the following.

$$\text{vol} := c_1 + c_2 \frac{1}{P} + c_3 \frac{1}{P^2} + c_4 T + c_5 \frac{T}{P} + c_6 \frac{T}{P^2} \dots c_9 \frac{T^2}{P^2}$$

Since each function, that make up the above equation, only has one coefficient in from of it, the coefficients can be solved by the least square fit process. The process is performed by substituting the above equation into a better format.

Let

$$f_0 := \text{vol} \quad ; \quad f_1 := 1 \quad ; \quad f_2 := \frac{1}{P} \quad ; \quad f_2 := \frac{1}{P^2} \quad ;$$

$$f_3 := T \quad ; \quad f_4 := \frac{T}{P} \quad ; \quad f_5 := \frac{T}{P^2} \quad ; \quad \dots \quad f_9 := \frac{T^2}{P^2}$$

Now the equation is in a linear type equation, in addition n was used instead of subscript 9, so as not to limit the process capability.

$$f_0 := c_1 f_1 + c_2 f_2 + c_3 f_3 \dots c_{n-1} f_{n-1} + c_n f_n$$

The coefficients can than be solved by the matrix equation

$$\begin{bmatrix}
 \Sigma(f \ f)_{1 \ 1} & \Sigma(f \ f)_{1 \ 2} & \Sigma(f \ f)_{1 \ 3} & \dots & \Sigma(f \ f)_{1 \ n} \\
 \Sigma(f \ f)_{2 \ 1} & \Sigma(f \ f)_{2 \ 2} & \Sigma(f \ f)_{2 \ 3} & \dots & \Sigma(f \ f)_{2 \ n} \\
 \vdots & \vdots & \vdots & & \vdots \\
 \Sigma(f \ f)_{n \ 1} & \Sigma(f \ f)_{n \ 2} & \Sigma(f \ f)_{n \ 3} & \dots & \Sigma(f \ f)_{n \ n}
 \end{bmatrix}
 \times
 \begin{bmatrix}
 C_1 \\
 C_2 \\
 \vdots \\
 C_n
 \end{bmatrix}
 =
 \begin{bmatrix}
 \Sigma(f \ f)_{0 \ 1} \\
 \Sigma(f \ f)_{0 \ 2} \\
 \vdots \\
 \Sigma(f \ f)_{0 \ n}
 \end{bmatrix}$$

Where the f functions are summation of all the data set given. The values of the coefficients are obtained by solving the above system of equations.

The coefficients obtained will be subject to run-off errors from the accuracy of the computer solving the system of equation and the software using the coefficients. For this reason, the property curvefit equation may experience 1 to 2 percent errors. Actually the coefficients are not off by much, but, because performance calculations are usually deferrence of two points the delta of big numbers are prone to higher inaccuracy.

APPENDIX D Raw and Reduced Data, Tests 11-13

This appendix consists of three test data sets for the following three configurations:

<u>Test Number</u>	<u>Design Configuration</u>
11	Design
12	Half Design
13	Quarter Design

The measurements consisted of three temperatures, five pressures, nozzle position and speed. These tests were essentially performed in order to recover the overall turbine efficiency not attainable from Tests 8 through 10 due to the two faulty thermocouples.

Each data set consists of an input and an output section. The input section is the test measurement values and the output section is the calculated performance.

2 STAGE PARTIAL ADMISSION TEST 11, DESIGN CONFIGURATION

FULL - DESIGN ADMISSION CONFIGURATION : 1ST STAGE 34.7% , 2ND STAGE 45.5%

turbine dia= 3.00 noz thr dia, in= 0.4000
 atm= 14.23 1st stg noz area= 0.2685
 leak 0.015 flo noz in dia= 0.8700

line number	input slice	input speed	input flow noz temp	input turb in temp	input turb out temp	input noz pos	input noz u/s press	input noz d/s press	input turb in press	input turb in press	input turb out press
1	77	9984.9	9.32	14.42	-6.17	-30	295.64	210.09	200.16	201.49	151.97
2	78	10014.2	9.19	11.66	-18.68	-30	352.90	213.59	200.09	201.95	121.42
3	79	10005.5	9.01	10.91	-23.68	-30	369.24	214.62	200.05	201.98	107.72
4	80	9986.2	9.06	10.17	-28.95	-30	379.75	215.29	199.94	201.95	94.09
5	125	10006.8	33.67	35.71	13.48	-10	308.53	212.24	201.88	203.59	151.47
6	126	10004.2	35.12	34.88	2.93	-10	361.24	214.18	200.45	202.60	121.71
7	127	9999.4	36.10	35.03	-1.98	-10	377.92	215.49	200.50	202.78	106.84
8	128	9984.0	36.82	35.33	-6.40	-10	386.73	215.40	199.68	202.08	93.07
9	30	10041.4	33.49	35.06	13.55	0	303.14	209.79	198.96	201.19	152.27
10	31	10094.6	35.01	34.38	1.69	0	364.13	213.33	198.44	201.19	120.61
11	32	10064.5	35.69	34.22	-3.43	0	383.13	216.19	200.06	203.12	107.28
12	33	10046.7	36.44	34.53	-7.56	0	390.55	215.78	198.72	201.85	93.78
13	116	10101.0	29.37	30.96	7.70	10	313.31	211.91	200.87	202.73	150.62
14	115	10130.4	30.16	29.49	-4.09	10	366.31	213.82	199.07	201.41	120.98
15	114	10153.6	29.89	28.72	-10.44	10	384.86	215.90	199.81	202.33	105.98
16	113	10151.4	28.90	27.82	-15.13	10	389.97	214.89	198.23	200.88	93.77
17	59	10002.8	34.53	36.78	14.42	40	304.88	210.47	199.46	201.29	152.48
18	60	9979.6	36.03	36.26	2.21	40	365.65	213.17	198.27	200.62	120.68
19	61	9931.1	36.53	35.78	-2.77	40	383.40	215.52	199.23	201.78	107.47
20	62	10024.3	36.94	35.90	-8.07	40	393.89	216.08	199.20	201.87	93.39
21	69	15032.7	18.45	24.42	2.02	-30	286.53	208.51	198.76	200.21	150.43
22	70	15049.3	17.94	21.50	-15.35	-30	348.61	213.54	200.03	202.03	121.11
23	71	15040.1	17.41	20.07	-23.07	-30	365.21	214.52	199.88	202.00	107.59
24	72	15050.6	16.80	18.64	-30.83	-30	376.00	214.53	199.06	201.26	92.57
25	117	15065.6	30.26	32.67	8.30	-10	296.91	210.73	200.79	202.46	151.12
26	118	15100.2	31.79	32.07	-6.84	-10	357.63	215.01	201.16	203.28	120.89
27	119	15111.6	33.53	32.79	-13.24	-10	374.81	215.84	200.86	203.19	106.36
28	120	15127.9	34.37	33.42	-18.51	-10	382.26	214.96	199.39	201.75	93.56
29	22	15083.7	29.58	31.57	7.40	0	299.16	210.77	200.06	202.17	151.19
30	23	15083.7	31.90	31.38	-7.43	0	357.46	213.71	199.35	201.93	121.70
31	24	15097.7	32.92	31.82	-14.16	0	374.90	214.64	198.99	201.75	107.20
32	25	15112.1	33.53	32.06	-20.97	0	386.22	215.12	198.67	201.55	93.03
33	108	15140.1	3.02	8.30	-16.56	10	297.85	211.43	200.80	202.60	151.38
34	107	15173.9	4.81	7.61	-32.79	10	360.54	215.87	201.04	203.50	121.02
35	106	15178.7	5.82	8.19	-38.78	10	375.51	215.90	199.92	202.46	106.97
36	105	15159.8	6.31	8.90	-44.67	10	381.20	213.84	197.20	199.76	92.39
37	51	15107.1	29.62	33.31	8.89	40	293.46	209.33	198.67	200.35	151.02
38	52	15097.9	32.15	33.13	-7.21	40	360.22	215.38	200.55	202.83	121.76
39	53	15118.5	33.40	33.51	-13.64	40	374.94	215.04	199.13	201.52	107.63
40	54	15131.6	34.46	34.03	-19.95	40	386.49	215.74	198.92	201.47	94.39

FULL - DESIGN ADMISSION CONFIGURATION : 1ST STAGE 34.7% , 2ND STAGE 45.5%

turbine dia= 3.00 noz thr dia, in= 0.4000
 atm= 14.23 1st stg noz area= 0.2685
 leak 0.015 flo noz in dia= 0.8700

line number	input slice	input speed	input flow temp	input noz temp	input turb in temp	input turb out temp	input noz pos	input noz u/s press	input noz d/s press	input turb in press	input turb in press	input turb out press
41	68	21050.2	20.74	26.94	6.43	-30	286.24	210.39	200.80	202.33	150.35	
42	18	21007.7	7.46	9.82	-27.11	-30	343.87	214.22	200.62	202.96	120.81	
43	67	21054.5	24.53	28.59	-10.66	-30	344.20	213.98	200.77	202.81	120.58	
44	9	21146.8	21.41	22.18	-24.43	-30	363.23	215.56	201.08	203.40	107.53	
45	65	21066.3	29.26	33.94	-14.42	-30	359.57	214.11	199.78	202.00	106.63	
46	66	21076.4	27.14	30.35	-25.82	-30	369.18	213.42	198.30	200.65	93.08	
47	17	21031.7	9.43	10.68	-44.26	-30	371.75	214.68	199.00	201.61	92.13	
48	90	20926.8	6.62	12.95	-8.96	-10	290.19	210.77	200.79	202.08	150.97	
49	19	21018.6	6.58	9.09	-29.71	-10	344.25	213.28	199.59	201.93	121.03	
50	89	20986.7	8.19	12.02	-29.05	-10	347.19	213.78	200.11	201.91	120.23	
51	87	20972.7	9.66	14.28	-34.28	-10	361.16	213.27	198.56	200.50	106.72	
52	8	21137.6	19.10	20.02	-29.78	-10	368.21	215.36	200.40	202.74	106.17	
53	88	20988.5	8.68	12.10	-45.50	-10	376.20	214.95	199.18	201.27	93.11	
54	16	21039.5	11.41	12.68	-44.45	-10	379.12	216.61	200.39	203.00	93.84	
55	21	20944.5	27.68	29.46	8.44	0	288.99	209.05	198.81	200.76	150.98	
56	20	21064.8	23.92	23.23	-16.73	0	346.66	211.82	198.09	200.46	120.64	
57	7	21138.5	15.93	17.63	-32.77	0	368.69	214.92	200.01	202.30	106.27	
58	15	21060.9	12.81	14.33	-43.94	0	381.09	216.62	200.35	203.00	94.27	
59	34	20923.1	36.65	35.12	-24.73	0	383.24	216.01	199.86	202.81	92.93	
60	86	20970.1	8.77	14.38	-8.18	10	290.40	209.37	199.05	200.42	150.39	
61	85	20989.3	9.74	13.71	-27.17	10	347.11	212.30	198.57	200.31	120.74	
62	10	21114.1	23.07	23.28	-25.67	10	366.76	214.35	199.60	201.90	108.48	
63	83	21006.4	13.19	18.88	-30.91	10	367.67	215.03	199.88	201.87	107.58	
64	104	21182.2	7.15	13.92	-37.23	10	364.19	213.74	198.44	200.85	106.16	
65	14	21034.7	14.82	16.65	-42.00	10	379.08	214.87	198.64	201.29	93.78	
66	84	20995.0	11.43	14.97	-44.09	10	381.53	216.18	199.87	202.05	93.82	
67	11	21135.4	17.45	21.62	-22.38	30	318.49	211.23	199.42	201.35	108.13	
68	50	21047.5	26.73	30.78	8.22	40	294.69	211.59	200.90	202.61	150.86	
69	49	21069.8	24.13	27.08	-14.59	40	348.10	213.01	198.89	200.96	120.23	
70	12	21104.5	24.19	24.11	-24.39	40	366.31	214.27	199.65	202.03	108.65	
71	47	21025.2	22.37	28.74	-21.61	40	363.44	213.75	198.45	200.72	107.19	
72	13	21037.3	16.47	18.62	-39.89	40	378.48	215.04	198.78	201.45	93.55	
73	48	21101.8	22.17	25.54	-34.61	40	377.61	214.74	198.38	200.84	92.74	
74	76	24916.5	10.21	16.56	1.40	-30	278.55	208.31	199.21	200.41	149.89	
75	75	24982.6	11.85	15.71	-18.05	-30	336.13	212.95	200.39	202.10	122.03	
76	74	24932.3	13.24	16.29	-27.86	-30	355.16	214.13	200.29	202.18	107.43	
77	73	25037.3	14.59	16.65	-37.94	-30	370.63	215.73	200.89	203.02	93.17	
78	124	25002.3	33.44	36.21	19.41	-10	284.96	210.57	201.56	203.07	152.53	
79	123	24985.2	34.40	35.13	-3.52	-10	344.95	213.31	200.49	202.49	120.34	
80	122	25035.6	34.55	34.60	-12.29	-10	357.75	213.20	199.45	201.58	108.81	

FULL - DESIGN ADMISSION CONFIGURATION : 1ST STAGE 34.7% , 2ND STAGE 45.5%

 turbine dia= 3.00 noz thr dia, in= 0.4000
 atm= 14.23 1st stg noz area= 0.2685
 leak 0.015 flo noz in dia= 0.8700

line number	input slice	input speed	input flow noz temp	input turb in temp	input turb out temp	input noz pos	input noz u/s press	input noz d/s press	input turb in press	input turb in press	input turb out press
=====	=====	=====	=====	=====	=====	=====	=====	=====	=====	=====	=====
81	121	25013.3	34.78	34.26	-23.72	-10	375.72	215.92	200.95	203.26	94.71
82	29	24975.2	33.20	35.35	16.96	0	290.63	209.18	199.03	201.15	149.70
83	28	24932.4	34.26	34.33	-5.27	0	348.16	213.22	199.50	202.11	120.37
84	27	24947.3	34.46	33.78	-15.89	0	366.67	215.14	200.09	202.88	107.11
85	26	24963.8	34.46	33.35	-26.68	0	380.68	216.51	200.50	203.42	93.34
86	109	24996.2	9.06	13.14	-3.36	10	283.47	209.27	199.38	201.06	152.15
87	110	25389.7	21.68	22.24	-15.59	10	343.73	212.43	198.99	201.14	121.55
88	111	25168.0	24.03	24.12	-24.11	10	362.27	213.57	198.90	201.21	107.78
89	112	25007.6	26.67	26.06	-34.63	10	381.09	216.34	200.41	202.91	92.31
90	58	25042.5	34.15	37.19	19.66	40	290.76	211.44	201.22	202.95	152.22
91	57	25344.5	35.14	35.96	-3.72	40	352.13	215.32	201.30	203.53	120.55
92	56	25068.8	35.21	35.33	-14.76	40	367.69	215.74	200.50	202.84	106.44
93	55	25079.7	35.15	34.90	-25.26	40	379.11	215.68	199.69	202.14	93.02

- 143 -

FULL - DESIGN ADMISSION CONFIGURATION : 1ST STAGE 34.7% , 2ND STAGE 45.5%

line number	noz pos	speed	flow temp R	noz press psia	noz inlet gamma	turb in temp R	turb in press psia	turb in inlet gamma	turb out temp R	turb out press psia	turb in enthalpy btu/lbm	turb in entropy btu/#-R	turb out enthalpy btu/lbm	turb out isen. enthalpy btu/lbm	sonic vel	flow rate #/sec	noz mach number	noz flow tot press
1	-30	9984.9	468.99	309.87	1.4478	474.09	215.06	1.4323	453.50	166.20	115.80	1.40996	110.97	107.66	1091.9	0.9464	0.1217	313.20
2	-30	10014.2	468.86	367.13	1.4567	471.33	215.25	1.4328	440.99	135.65	115.09	1.40839	107.98	100.87	1091.9	1.1268	0.1223	371.15
3	-30	10005.5	468.68	383.47	1.4593	470.58	215.24	1.4329	435.99	121.95	114.90	1.40799	106.79	97.82	1091.8	1.1787	0.1224	387.68
4	-30	9986.2	468.73	393.98	1.4609	469.84	215.18	1.4330	430.72	108.32	114.71	1.40761	105.61	94.66	1091.9	1.2118	0.1225	398.31
5	-10	10006.8	493.34	322.76	1.4435	495.38	216.96	1.4291	473.15	165.70	121.22	1.42050	115.98	112.33	1118.6	0.9604	0.1218	326.23
6	-10	10004.2	494.79	375.47	1.4501	494.55	215.75	1.4290	462.60	135.94	121.02	1.42050	113.47	106.07	1120.2	1.1199	0.1223	379.55
7	-10	9999.4	495.77	392.15	1.4520	494.70	215.87	1.4290	457.69	121.07	121.06	1.42054	112.31	102.73	1121.4	1.1697	0.1224	396.43
8	-10	9984.0	496.49	400.96	1.4530	495.00	215.11	1.4289	453.27	107.30	121.14	1.42096	111.34	99.59	1122.1	1.1958	0.1224	405.35
9	0	10041.4	493.16	317.37	1.4428	494.73	214.30	1.4288	473.22	166.50	121.08	1.42111	115.99	112.77	1118.3	0.9441	0.1217	320.78
10	0	10094.6	494.68	378.36	1.4505	494.05	214.05	1.4289	461.36	134.84	120.91	1.42085	113.16	105.97	1120.1	1.1289	0.1223	382.47
11	0	10064.5	495.36	397.36	1.4528	493.89	215.82	1.4291	456.24	121.51	120.85	1.42014	111.94	102.66	1120.9	1.1862	0.1224	401.70
12	0	10046.7	496.11	404.78	1.4536	494.20	214.52	1.4289	452.11	108.01	120.94	1.42076	111.04	99.69	1121.7	1.2080	0.1225	409.21
13	10	10101.0	489.04	327.54	1.4452	490.63	216.03	1.4297	467.37	164.85	120.02	1.41837	114.51	111.18	1114.0	0.9796	0.1218	331.07
14	10	10130.4	489.83	380.54	1.4522	489.16	214.47	1.4297	455.58	135.21	119.65	1.41816	111.69	104.89	1114.9	1.1417	0.1223	384.69
15	10	10153.6	489.56	399.09	1.4548	488.39	215.30	1.4299	449.23	120.21	119.45	1.41747	110.17	101.26	1114.7	1.1992	0.1225	403.46
16	10	10151.4	488.57	404.20	1.4558	487.49	213.78	1.4299	444.54	108.00	119.23	1.41754	109.12	98.41	1113.5	1.2163	0.1225	408.63
17	40	10002.8	494.20	319.11	1.4428	496.45	214.60	1.4286	474.09	166.71	121.51	1.42189	116.21	113.17	1119.4	0.9483	0.1217	322.53
18	40	9979.6	495.70	379.88	1.4504	495.93	213.68	1.4286	461.88	134.91	121.39	1.42195	113.29	106.47	1121.1	1.1323	0.1223	384.02
19	40	9931.1	496.20	397.63	1.4526	495.45	214.73	1.4288	456.90	121.70	121.26	1.42133	112.11	103.20	1121.7	1.1860	0.1224	401.97
20	40	10024.3	496.61	408.12	1.4539	495.57	214.77	1.4288	451.60	107.62	121.29	1.42138	110.91	99.84	1122.2	1.2175	0.1225	412.59
21	-30	15032.7	478.12	300.76	1.4441	484.09	213.71	1.4304	461.69	164.66	118.37	1.41578	113.07	109.97	1101.7	0.9083	0.1216	303.98
22	-30	15049.3	477.61	362.84	1.4533	481.17	215.26	1.4311	444.32	135.34	117.60	1.41367	108.83	103.01	1101.4	1.1022	0.1222	366.80
23	-30	15040.1	477.08	379.44	1.4559	479.74	215.17	1.4313	436.60	121.82	117.24	1.41295	106.95	99.77	1100.9	1.1547	0.1224	383.59
24	-30	15050.6	476.47	390.23	1.4577	478.31	214.39	1.4314	428.84	106.80	116.88	1.41246	105.16	96.13	1100.2	1.1892	0.1225	394.51
25	-10	15065.6	489.93	311.14	1.4427	492.34	215.85	1.4294	467.97	165.35	120.45	1.41932	114.66	111.72	1114.9	0.9283	0.1217	314.47
26	-10	15100.2	491.46	371.86	1.4505	491.74	216.45	1.4296	452.83	135.12	120.30	1.41880	111.00	105.15	1116.7	1.1129	0.1222	375.90
27	-10	15111.6	493.20	389.04	1.4524	492.46	216.25	1.4294	446.43	120.59	120.48	1.41924	109.46	102.08	1118.6	1.1635	0.1224	393.28
28	-10	15127.9	494.04	396.49	1.4531	493.09	214.80	1.4291	441.16	107.79	120.65	1.42009	108.27	99.37	1119.4	1.1853	0.1224	400.83
29	0	15083.7	489.25	313.39	1.4432	491.24	215.34	1.4295	467.07	165.42	120.18	1.41894	114.43	111.55	1114.1	0.9359	0.1217	316.75
30	0	15083.7	491.57	371.69	1.4505	491.05	214.87	1.4295	452.24	135.93	120.13	1.41900	110.84	105.41	1116.8	1.1123	0.1222	375.74
31	0	15097.7	492.59	389.13	1.4525	491.49	214.60	1.4293	445.51	121.43	120.25	1.41933	109.22	102.31	1117.9	1.1646	0.1224	393.38
32	0	15112.1	493.20	400.45	1.4539	491.73	214.34	1.4293	438.70	107.26	120.31	1.41954	107.65	99.01	1118.5	1.1985	0.1225	404.83
33	10	15140.1	462.69	312.08	1.4499	467.97	215.93	1.4335	443.11	165.61	114.22	1.40632	108.33	105.95	1085.0	0.9604	0.1218	315.45
34	10	15173.9	464.48	374.77	1.4594	467.28	216.50	1.4337	426.88	135.25	114.04	1.40574	104.39	99.70	1087.2	1.1569	0.1224	378.88
35	10	15178.7	465.49	389.74	1.4614	467.86	215.42	1.4334	420.89	121.20	114.20	1.40644	102.96	97.05	1088.2	1.2030	0.1225	394.03
36	10	15159.8	465.98	395.43	1.4622	468.57	212.71	1.4329	415.00	106.62	114.41	1.40780	101.65	94.31	1088.6	1.2203	0.1226	399.79
37	40	15107.1	489.29	307.69	1.4424	492.98	213.74	1.4290	468.56	165.25	120.64	1.42041	114.81	112.20	1114.0	0.9184	0.1217	310.98
38	40	15097.9	491.82	374.45	1.4508	492.80	215.92	1.4293	452.47	135.99	120.57	1.41954	110.90	105.66	1117.0	1.1204	0.1223	378.52
39	40	15118.5	493.07	389.17	1.4524	493.18	214.55	1.4291	446.03	121.86	120.68	1.42022	109.34	102.78	1118.3	1.1641	0.1224	393.42
40	40	15131.6	494.13	400.72	1.4536	493.70	214.42	1.4290	439.72	108.62	120.81	1.42053	107.89	99.76	1119.5	1.1981	0.1225	405.10

- 144 -

NASA CR-179548
R/RD 86-214

FULL - DESIGN ADMISSION CONFIGURATION : 1ST STAGE 34.7% , 2ND STAGE 45.5%

line number	noz pos	output speed	output flow noz temp R	output flow noz press psia	output flow noz inlet gamma	output turb in temp R	output turb in press psia	output turb in inlet gamma	output turb out temp R	output turb out press psia	output turb in enthalpy btu/lbm	output turb in entropy btu/#-R	output turb out enthalpy btu/lbm	output turb out enthalpy btu/lbm	isen. sonic vel	output flow noz flowrate #/sec	output mach number	output flow noz tot press
41	-30	21050.2	480.41	300.47	1.4435	486.61	215.79	1.4303	466.10	164.58	118.99	1.41636	114.19	110.21	1104.3	0.9051	0.1216	303.69
42	-30	21007.7	467.13	358.10	1.4559	469.49	216.02	1.4332	432.56	135.04	114.61	1.40712	105.84	100.22	1090.1	1.1005	0.1222	362.00
43	-30	21054.5	484.20	358.43	1.4507	488.26	216.02	1.4300	449.01	134.81	119.41	1.41714	110.03	104.37	1108.6	1.0803	0.1222	362.32
44	-30	21146.8	481.08	377.46	1.4544	481.85	216.47	1.4311	435.24	121.76	117.77	1.41361	106.60	100.03	1105.4	1.1433	0.1223	381.58
45	-30	21066.3	488.93	373.80	1.4515	493.61	215.12	1.4291	445.25	120.86	120.78	1.42024	109.15	102.56	1113.6	1.1220	0.1223	377.87
46	-30	21076.4	486.81	383.41	1.4535	490.02	213.70	1.4295	433.85	107.31	119.88	1.41889	106.42	98.76	1111.3	1.1544	0.1224	387.60
47	-30	21031.7	469.10	385.98	1.4596	470.35	214.53	1.4328	415.41	106.36	114.84	1.40812	101.76	94.36	1092.2	1.1860	0.1225	390.22
48	-10	20926.8	466.29	304.42	1.4477	472.62	215.66	1.4326	450.71	165.20	115.41	1.40895	110.27	107.02	1088.9	0.9322	0.1217	307.70
49	-10	21018.6	466.25	358.48	1.4562	468.76	214.99	1.4332	429.97	135.26	114.43	1.40709	105.18	100.25	1089.0	1.1029	0.1222	362.39
50	-10	20986.7	467.86	361.42	1.4562	471.69	215.24	1.4327	430.62	134.46	115.18	1.40860	105.35	100.71	1090.7	1.1101	0.1223	365.36
51	-10	20972.7	469.33	375.39	1.4578	473.95	213.76	1.4321	425.39	120.95	115.77	1.41034	104.10	98.54	1092.2	1.1523	0.1224	379.51
52	-10	21137.6	478.77	382.44	1.4558	479.69	215.80	1.4314	429.89	120.40	117.22	1.41269	105.25	99.36	1102.9	1.1618	0.1224	386.62
53	-10	20988.5	468.35	390.43	1.4605	471.77	214.45	1.4326	414.17	107.34	115.21	1.40892	101.43	94.91	1091.3	1.2011	0.1225	394.73
54	-10	21039.5	471.08	393.35	1.4600	472.35	215.92	1.4327	415.22	108.07	115.34	1.40871	101.68	95.01	1094.5	1.2065	0.1225	397.68
55	0	20944.5	487.35	303.22	1.4422	489.13	214.02	1.4296	468.11	165.21	119.65	1.41831	114.70	111.22	1112.0	0.9066	0.1216	306.47
56	0	21064.8	483.59	360.89	1.4513	482.90	213.50	1.4306	442.94	134.87	118.06	1.41522	108.48	103.56	1108.1	1.0887	0.1222	364.82
57	0	21138.5	475.60	382.92	1.4569	477.30	215.39	1.4318	426.90	120.50	116.61	1.41156	104.49	98.93	1099.4	1.1675	0.1224	387.11
58	0	21060.9	472.48	395.32	1.4598	474.00	215.91	1.4324	415.73	108.50	115.77	1.40960	101.80	95.46	1096.0	1.2107	0.1225	399.67
59	0	20923.1	496.32	397.47	1.4526	494.79	215.56	1.4290	434.94	107.16	121.08	1.42069	106.70	99.44	1122.0	1.1853	0.1224	401.81
60	10	20970.1	468.44	304.63	1.4471	474.05	213.97	1.4321	451.49	164.62	115.80	1.41033	110.47	107.52	1091.2	0.9306	0.1217	307.91
61	10	20989.3	469.41	361.34	1.4556	473.38	213.67	1.4322	432.50	134.97	115.63	1.41007	105.82	101.42	1092.3	1.1079	0.1223	365.29
62	10	21114.1	482.74	380.99	1.4544	482.95	214.98	1.4308	434.00	122.71	118.06	1.41472	106.28	100.69	1107.2	1.1521	0.1224	385.16
63	10	21006.4	472.86	381.90	1.4577	478.55	215.11	1.4315	428.76	121.81	116.94	1.41233	104.95	99.53	1096.1	1.1680	0.1224	386.09
64	10	21182.2	466.82	378.42	1.4592	473.59	213.87	1.4322	422.44	120.39	115.68	1.41011	103.36	98.32	1089.3	1.1652	0.1225	382.57
65	10	21034.7	474.49	393.31	1.4588	476.32	214.20	1.4317	417.67	108.01	116.38	1.41147	102.30	96.05	1098.1	1.2016	0.1225	397.63
66	10	20995.0	471.10	395.76	1.4604	474.64	215.19	1.4322	415.58	108.05	115.93	1.41020	101.77	95.58	1094.3	1.2141	0.1226	400.12
67	30	21135.4	477.12	332.72	1.4490	481.29	214.62	1.4310	437.29	122.36	117.64	1.41397	107.12	100.31	1100.8	1.0088	0.1220	336.32
68	40	21047.5	486.40	308.92	1.4432	490.45	215.99	1.4297	467.89	165.09	119.97	1.41830	114.64	111.20	1111.0	0.9251	0.1217	312.23
69	40	21069.8	483.80	362.33	1.4514	486.75	214.15	1.4300	445.08	134.46	119.04	1.41702	109.03	104.24	1108.1	1.0929	0.1222	366.27
70	40	21104.5	483.86	380.54	1.4540	483.78	215.07	1.4306	435.28	122.88	118.28	1.41513	106.60	100.90	1108.4	1.1493	0.1223	384.69
71	40	21025.2	482.04	377.67	1.4541	488.41	213.81	1.4297	438.06	121.42	119.47	1.41801	107.32	101.76	1106.0	1.1427	0.1224	381.80
72	40	21037.3	476.14	392.71	1.4582	478.29	214.34	1.4314	419.78	107.78	116.88	1.41247	102.84	96.38	1099.9	1.1975	0.1225	397.03
73	40	21101.8	481.84	391.84	1.4562	485.21	213.84	1.4302	425.06	106.97	118.65	1.41632	104.20	97.66	1105.9	1.1870	0.1225	396.14
74	-30	24916.5	469.88	292.78	1.4449	476.23	214.04	1.4317	461.07	164.12	116.35	1.41147	112.92	107.94	1092.7	0.8919	0.1216	295.91
75	-30	24982.6	471.52	350.36	1.4533	475.38	215.47	1.4321	441.62	136.26	116.12	1.41050	108.14	101.87	1094.8	1.0707	0.1221	354.17
76	-30	24932.3	472.91	369.39	1.4557	475.96	215.47	1.4320	431.81	121.66	116.27	1.41082	105.73	98.88	1096.3	1.1286	0.1223	373.42
77	-30	25037.3	474.26	384.86	1.4576	476.32	216.19	1.4320	421.73	107.40	116.36	1.41076	103.35	95.63	1097.9	1.1754	0.1224	389.08
78	-10	25002.3	493.11	299.19	1.4404	495.88	216.55	1.4289	479.08	166.76	121.35	1.42090	117.48	112.72	1118.3	0.8886	0.1215	302.39
79	-10	24985.2	494.07	359.18	1.4481	494.80	215.72	1.4290	456.15	134.57	121.08	1.42064	111.84	105.82	1119.4	1.0709	0.1221	363.07
80	-10	25035.6	494.22	371.98	1.4498	494.27	214.74	1.4289	447.38	123.04	120.96	1.42072	109.68	103.25	1119.6	1.1099	0.1222	376.03

- 145 -

FULL - DESIGN ADMISSION CONFIGURATION : 1ST STAGE 34.7% , 2ND STAGE 45.5%

line number	noz pos	output speed	output flow noz temp R	output flow noz press psia	output flow noz inlet gamma	output turb in temp R	output turb in press psia	output turb in inlet gamma	output turb out temp R	output turb out press psia	output turb in enthalpy btu/lbm	output turb in entropy btu/#-R	output turb out enthalpy btu/lbm	output turb out enthalpy btu/lbm	output isen. sonic vel	output flow noz flowrate #/sec	output mach number	output flow noz tot press
81	-10	25013.3	494.45	389.95	1.4521	493.93	216.33	1.4292	435.95	108.94	120.86	1.41997	106.93	99.62	1119.9	1.1647	0.1224	394.21
82	0	24975.2	492.87	304.86	1.4412	495.02	214.32	1.4288	476.63	163.93	121.15	1.42125	116.87	112.32	1118.0	0.9062	0.1216	308.13
83	0	24932.4	493.93	362.39	1.4486	494.00	215.03	1.4290	454.40	134.60	120.88	1.42047	111.40	105.75	1119.3	1.0809	0.1221	366.32
84	0	24947.3	494.13	380.90	1.4510	493.45	215.72	1.4292	443.78	121.34	120.74	1.41994	108.78	102.54	1119.6	1.1374	0.1223	385.05
85	0	24963.8	494.13	394.91	1.4529	493.02	216.19	1.4293	432.99	107.57	120.62	1.41955	106.20	99.10	1119.6	1.1803	0.1224	399.23
86	10	24996.2	468.73	297.70	1.4460	472.81	214.45	1.4324	456.31	166.38	115.47	1.40948	111.69	107.48	1091.6	0.9085	0.1216	300.89
87	10	25389.7	481.35	357.96	1.4515	481.91	214.29	1.4308	444.08	135.78	117.80	1.41442	108.77	103.42	1105.6	1.0823	0.1222	361.85
88	10	25168.0	483.70	376.50	1.4534	483.79	214.28	1.4305	435.56	122.01	118.28	1.41541	106.68	100.82	1108.2	1.1369	0.1223	380.60
89	10	25007.6	486.34	395.32	1.4553	485.73	215.89	1.4304	425.04	106.54	118.77	1.41586	104.20	97.37	1111.2	1.1918	0.1224	399.65
90	40	25042.5	493.82	304.99	1.4410	496.86	216.32	1.4288	479.33	166.45	121.60	1.42149	117.54	112.93	1119.0	0.9056	0.1216	308.25
91	40	25344.5	494.81	366.36	1.4489	495.63	216.65	1.4290	455.95	134.78	121.29	1.42074	111.79	105.91	1120.2	1.0920	0.1222	370.34
92	40	25068.8	494.88	381.92	1.4509	495.00	215.90	1.4290	444.91	120.67	121.13	1.42068	109.07	102.70	1120.3	1.1396	0.1223	386.08
93	40	25079.7	494.82	393.34	1.4525	494.57	215.15	1.4290	434.41	107.25	121.03	1.42073	106.57	99.48	1120.3	1.1746	0.1224	397.64

NASA CR-179548
R/RD 86-214

line number	output flow para fw1	output speed para sp	output turb press ratio	output isen delta enthalpy	output turb c0	output turb mean blade speed	output U/CO	output turb eff temp	output flow para pred	output flow para ratio act/pred	output EFF PRED	output EFF TEMP ACT/PRED	output gas z fact	output critical theta	output delta	output epsilon	output equiv flow lbm/s	output equiv speed rpm
1	2.651	185.23	1.294	8.14	638.4	130.69	0.205	0.593	2.773	0.956	0.548	1.081	0.9892	0.943	14.634	0.988	0.0620	10281.3
2	3.144	186.31	1.587	14.22	843.8	131.08	0.155	0.500	3.400	0.925	0.451	1.107	0.9889	0.937	14.647	0.987	0.0735	10342.7
3	3.286	186.30	1.765	17.08	924.9	130.96	0.142	0.475	3.524	0.932	0.419	1.133	0.9888	0.936	14.646	0.987	0.0769	10342.1
4	3.377	186.09	1.986	20.05	1002.1	130.71	0.130	0.454	3.406	0.992	0.391	1.161	0.9887	0.934	14.642	0.987	0.0790	10330.7
5	2.725	181.60	1.309	8.89	667.4	130.98	0.196	0.589	2.831	0.962	0.534	1.103	0.9915	0.987	14.763	0.989	0.0639	10073.3
6	3.193	181.70	1.587	14.95	865.5	130.94	0.151	0.505	3.404	0.938	0.442	1.141	0.9914	0.985	14.681	0.989	0.0749	10079.3
7	3.334	181.59	1.783	18.33	958.1	130.88	0.137	0.477	3.532	0.944	0.407	1.174	0.9914	0.985	14.689	0.989	0.0782	10072.9
8	3.421	181.26	2.005	21.55	1039.0	130.68	0.126	0.455	3.402	1.006	0.379	1.200	0.9915	0.986	14.638	0.989	0.0802	10054.3
9	2.711	182.35	1.287	8.31	645.2	131.43	0.204	0.612	2.763	0.981	0.547	1.120	0.9915	0.986	14.582	0.989	0.0636	10114.9
10	3.243	183.44	1.587	14.94	864.9	132.13	0.153	0.518	3.403	0.953	0.446	1.164	0.9914	0.984	14.565	0.989	0.0760	10175.7
11	3.379	182.92	1.776	18.19	954.4	131.73	0.138	0.490	3.529	0.957	0.410	1.195	0.9914	0.984	14.686	0.989	0.0792	10147.1
12	3.463	182.54	1.986	21.25	1031.6	131.50	0.127	0.466	3.419	1.013	0.383	1.216	0.9914	0.984	14.597	0.989	0.0812	10125.9
13	2.778	184.20	1.310	8.83	665.1	132.21	0.199	0.623	2.825	0.983	0.538	1.157	0.9910	0.977	14.700	0.989	0.0651	10218.6
14	3.257	185.01	1.586	14.76	859.9	132.60	0.154	0.539	3.400	0.958	0.449	1.202	0.9909	0.974	14.594	0.989	0.0763	10264.1
15	3.405	185.58	1.791	18.19	954.5	132.90	0.139	0.510	3.527	0.965	0.413	1.235	0.9908	0.973	14.650	0.988	0.0798	10296.0
16	3.475	185.71	1.979	20.83	1021.3	132.87	0.130	0.486	3.415	1.017	0.390	1.245	0.9908	0.971	14.547	0.988	0.0814	10303.6
17	2.724	181.33	1.287	8.34	646.5	130.93	0.203	0.636	2.767	0.984	0.545	1.167	0.9917	0.989	14.603	0.989	0.0639	10058.2
18	3.264	181.01	1.584	14.92	864.5	130.62	0.151	0.542	3.401	0.960	0.442	1.228	0.9916	0.988	14.540	0.989	0.0765	10040.2
19	3.401	180.21	1.764	18.05	950.9	129.99	0.137	0.507	3.531	0.963	0.407	1.246	0.9916	0.987	14.612	0.989	0.0797	9996.4
20	3.491	181.88	1.996	21.45	1036.5	131.21	0.127	0.484	3.410	1.024	0.381	1.270	0.9916	0.987	14.614	0.989	0.0819	10088.9
21	2.587	275.97	1.298	8.40	648.6	196.76	0.303	0.630	2.612	0.990	0.641	0.984	0.9904	0.964	14.542	0.988	0.0606	15313.2
22	3.107	277.12	1.591	14.60	855.0	196.98	0.230	0.601	3.260	0.953	0.586	1.027	0.9900	0.958	14.648	0.988	0.0728	15378.1
23	3.251	277.36	1.766	17.47	935.3	196.86	0.210	0.589	3.422	0.950	0.558	1.057	0.9899	0.955	14.641	0.988	0.0761	15392.2
24	3.356	277.97	2.007	20.76	1019.6	197.00	0.193	0.565	3.366	0.997	0.529	1.068	0.9897	0.952	14.588	0.988	0.0786	15426.7
25	2.640	274.25	1.305	8.74	661.5	197.19	0.298	0.663	2.637	1.001	0.639	1.036	0.9912	0.981	14.688	0.989	0.0619	15213.9
26	3.154	275.05	1.602	15.15	871.1	197.65	0.227	0.614	3.279	0.962	0.581	1.056	0.9911	0.979	14.729	0.989	0.0739	15258.3
27	3.303	275.05	1.793	18.40	960.0	197.80	0.206	0.599	3.433	0.962	0.550	1.088	0.9912	0.981	14.715	0.989	0.0774	15258.4
28	3.389	275.17	1.993	21.29	1032.6	198.01	0.192	0.582	3.376	1.004	0.526	1.106	0.9913	0.982	14.616	0.989	0.0795	15264.7
29	2.665	274.89	1.302	8.63	657.3	197.43	0.300	0.666	2.625	1.015	0.640	1.041	0.9911	0.978	14.653	0.989	0.0625	15249.6
30	3.173	274.94	1.581	14.72	858.7	197.43	0.230	0.631	3.250	0.976	0.585	1.079	0.9911	0.978	14.621	0.989	0.0744	15252.7
31	3.328	275.07	1.767	17.94	948.0	197.61	0.208	0.615	3.425	0.972	0.554	1.109	0.9912	0.979	14.603	0.989	0.0780	15259.7
32	3.430	275.27	1.998	21.30	1032.8	197.80	0.192	0.594	3.371	1.017	0.526	1.131	0.9912	0.979	14.585	0.989	0.0804	15270.5
33	2.661	282.69	1.304	8.27	643.5	198.17	0.308	0.713	2.623	1.015	0.642	1.111	0.9884	0.931	14.693	0.987	0.0622	15694.7
34	3.195	283.53	1.601	14.34	847.4	198.61	0.234	0.673	3.264	0.979	0.591	1.139	0.9883	0.929	14.732	0.987	0.0747	15741.8
35	3.341	283.44	1.777	17.15	926.8	198.67	0.214	0.656	3.420	0.977	0.563	1.163	0.9884	0.930	14.658	0.987	0.0781	15736.6
36	3.435	282.88	1.995	20.09	1003.2	198.43	0.198	0.635	3.380	1.016	0.537	1.183	0.9887	0.932	14.474	0.987	0.0804	15704.6
37	2.639	274.83	1.293	8.44	650.2	197.74	0.304	0.690	2.600	1.015	0.641	1.076	0.9913	0.982	14.544	0.989	0.0619	15245.5
38	3.186	274.71	1.588	14.91	864.3	197.62	0.229	0.649	3.260	0.977	0.583	1.112	0.9912	0.982	14.693	0.989	0.0747	15239.1
39	3.333	274.98	1.761	17.90	947.0	197.89	0.209	0.633	3.422	0.974	0.555	1.140	0.9913	0.982	14.599	0.989	0.0781	15253.8
40	3.434	275.07	1.974	21.05	1026.9	198.06	0.193	0.614	3.391	1.013	0.528	1.163	0.9914	0.983	14.591	0.989	0.0805	15258.8

- 147 -

line number	output flow para fw1	output speed para sp	output turb press ratio	output isen delta enthalpy	output turb c0	output turb mean blade speed	output U/C0	output turb eff temp	output flow para pred	output flow para ratio act/pred	output EFF PRED	output EFF TEMP ACT/PRED	output gas z fact	output critical theta	output delta	output epsilon	output equiv flow lbm/s	output equiv speed rpm
41	2.559	385.44	1.311	8.78	663.1	275.53	0.416	0.547	2.555	1.002	0.570	0.959	0.9906	0.969	14.684	0.988	0.0600	21385.7
42	3.054	391.61	1.600	14.39	849.0	274.97	0.324	0.610	3.120	0.979	0.643	0.949	0.9886	0.934	14.699	0.987	0.0714	21740.7
43	3.057	384.87	1.602	15.05	868.1	275.58	0.317	0.624	3.131	0.976	0.643	0.971	0.9908	0.972	14.699	0.988	0.0716	21352.8
44	3.207	389.12	1.778	17.74	942.6	276.79	0.294	0.629	3.325	0.964	0.638	0.987	0.9901	0.959	14.730	0.988	0.0751	21592.9
45	3.206	382.99	1.780	18.23	955.5	275.74	0.289	0.638	3.332	0.962	0.636	1.004	0.9914	0.983	14.638	0.989	0.0751	21245.5
46	3.308	384.57	1.991	21.12	1028.4	275.87	0.268	0.637	3.418	0.968	0.624	1.022	0.9910	0.976	14.542	0.989	0.0775	21335.4
47	3.317	391.70	2.017	20.48	1012.8	275.28	0.272	0.639	3.416	0.971	0.626	1.020	0.9888	0.935	14.598	0.987	0.0776	21744.9
48	2.599	388.81	1.305	8.39	648.2	273.91	0.423	0.613	2.539	1.024	0.558	1.099	0.9890	0.940	14.675	0.987	0.0608	21582.7
49	3.072	392.12	1.590	14.18	842.8	275.11	0.326	0.653	3.105	0.990	0.642	1.016	0.9886	0.932	14.629	0.987	0.0719	21769.4
50	3.099	390.31	1.601	14.47	851.5	274.70	0.323	0.679	3.123	0.992	0.643	1.057	0.9889	0.938	14.646	0.987	0.0725	21666.5
51	3.246	389.12	1.767	17.23	929.0	274.51	0.295	0.677	3.316	0.979	0.639	1.061	0.9893	0.943	14.545	0.988	0.0760	21598.7
52	3.262	389.82	1.792	17.86	945.8	276.67	0.293	0.670	3.336	0.978	0.637	1.051	0.9898	0.955	14.684	0.988	0.0764	21633.8
53	3.365	390.31	1.998	20.29	1008.2	274.72	0.272	0.679	3.417	0.985	0.627	1.084	0.9890	0.938	14.593	0.987	0.0787	21666.5
54	3.359	391.02	1.998	20.33	1009.1	275.39	0.273	0.672	3.416	0.983	0.627	1.072	0.9890	0.940	14.693	0.987	0.0786	21705.5
55	2.592	382.52	1.295	8.43	649.6	274.14	0.422	0.588	2.518	1.029	0.559	1.052	0.9909	0.974	14.563	0.989	0.0607	21221.9
56	3.100	387.19	1.583	14.50	852.3	275.72	0.324	0.661	3.100	1.000	0.643	1.028	0.9903	0.961	14.528	0.988	0.0726	21485.1
57	3.276	390.81	1.787	17.69	941.2	276.68	0.294	0.686	3.331	0.983	0.638	1.075	0.9896	0.950	14.656	0.988	0.0767	21690.4
58	3.377	390.73	1.990	20.31	1008.5	275.67	0.273	0.688	3.416	0.989	0.627	1.096	0.9892	0.943	14.692	0.987	0.0790	21688.4
59	3.383	379.93	2.012	21.64	1041.1	273.86	0.263	0.665	3.418	0.990	0.620	1.072	0.9915	0.986	14.668	0.989	0.0793	21075.1
60	2.619	389.03	1.300	8.27	643.7	274.48	0.426	0.644	2.524	1.038	0.551	1.169	0.9893	0.943	14.559	0.988	0.0613	21593.4
61	3.121	389.66	1.583	14.20	843.5	274.73	0.326	0.690	3.098	1.007	0.643	1.074	0.9892	0.942	14.539	0.988	0.0730	21629.1
62	3.258	388.07	1.752	17.37	932.8	276.36	0.296	0.678	3.304	0.986	0.639	1.062	0.9902	0.961	14.629	0.988	0.0763	21534.1
63	3.286	387.87	1.766	17.41	933.8	274.95	0.294	0.688	3.316	0.991	0.638	1.078	0.9897	0.952	14.637	0.988	0.0769	21525.8
64	3.280	393.15	1.777	17.35	932.3	277.25	0.297	0.710	3.321	0.988	0.639	1.111	0.9892	0.942	14.553	0.988	0.0767	21823.0
65	3.387	389.29	1.983	20.33	1009.0	275.32	0.273	0.692	3.416	0.991	0.627	1.104	0.9895	0.948	14.575	0.988	0.0793	21606.7
66	3.400	389.25	1.992	20.36	1009.8	274.80	0.272	0.696	3.417	0.995	0.626	1.111	0.9893	0.944	14.643	0.988	0.0796	21605.5
67	2.853	389.13	1.754	17.33	931.8	276.64	0.297	0.607	3.305	0.863	0.639	0.950	0.9901	0.958	14.604	0.988	0.0668	21594.3
68	2.624	383.88	1.308	8.78	663.0	275.49	0.416	0.607	2.549	1.029	0.570	1.066	0.9910	0.977	14.697	0.989	0.0615	21296.6
69	3.115	385.74	1.593	14.81	861.2	275.78	0.320	0.676	3.116	0.999	0.643	1.052	0.9907	0.969	14.572	0.988	0.0730	21402.4
70	3.251	387.56	1.750	17.38	933.0	276.24	0.296	0.672	3.303	0.984	0.639	1.051	0.9903	0.963	14.635	0.988	0.0762	21505.3
71	3.267	384.27	1.761	17.71	941.9	275.20	0.292	0.686	3.315	0.986	0.637	1.076	0.9909	0.973	14.549	0.988	0.0766	21319.8
72	3.380	388.54	1.989	20.50	1013.3	275.36	0.272	0.685	3.417	0.989	0.626	1.093	0.9897	0.952	14.585	0.988	0.0791	21563.4
73	3.382	386.94	1.999	20.99	1025.2	276.20	0.269	0.689	3.417	0.990	0.625	1.103	0.9905	0.966	14.551	0.988	0.0792	21470.0
74	2.515	461.18	1.304	8.42	649.3	326.13	0.502	0.408	2.481	1.014	0.335	1.219	0.9895	0.948	14.565	0.988	0.0589	25596.6
75	2.997	462.82	1.581	14.25	844.7	327.00	0.387	0.560	3.029	0.989	0.608	0.922	0.9894	0.946	14.662	0.988	0.0701	25688.3
76	3.161	461.60	1.771	17.39	933.3	326.34	0.350	0.606	3.258	0.970	0.636	0.953	0.9894	0.947	14.662	0.988	0.0740	25620.4
77	3.282	463.37	2.013	20.73	1019.0	327.71	0.322	0.628	3.372	0.973	0.643	0.976	0.9894	0.948	14.711	0.988	0.0768	25718.3
78	2.528	453.51	1.299	8.63	657.4	327.26	0.498	0.449	2.473	1.022	0.353	1.274	0.9915	0.988	14.735	0.989	0.0593	25155.5
79	3.055	453.69	1.603	15.26	874.3	327.03	0.374	0.606	3.069	0.995	0.620	0.976	0.9915	0.986	14.679	0.989	0.0716	25166.3
80	3.179	454.85	1.745	17.70	941.6	327.69	0.348	0.637	3.240	0.981	0.637	1.000	0.9914	0.985	14.612	0.989	0.0745	25231.1

line number	output flow para fwl	output speed para sp	output turb press ratio	output isen turb delta enthalpy	output turb c0	output turb mean blade speed	output U/C0	output turb eff temp	output flow para pred	output flow para ratio act/pred	output EFF PRED	output EFF TEMP ACT/PRED	output gas z fact	output critical theta	output delta	output epsilon	output equiv flow lbm/s	output equiv speed rpm
81	3.310	454.60	1.986	21.24	1031.4	327.40	0.317	0.656	3.377	0.980	0.643	1.020	0.9913	0.984	14.721	0.989	0.0776	25217.5
82	2.602	453.41	1.307	8.83	664.9	326.90	0.492	0.485	2.494	1.043	0.376	1.289	0.9915	0.986	14.584	0.989	0.0610	25150.5
83	3.091	453.10	1.598	15.13	870.5	326.34	0.375	0.627	3.061	1.010	0.620	1.012	0.9914	0.984	14.632	0.989	0.0725	25134.1
84	3.240	453.62	1.778	18.19	954.6	326.53	0.342	0.657	3.271	0.991	0.639	1.029	0.9913	0.983	14.679	0.989	0.0759	25163.6
85	3.353	454.12	2.010	21.53	1038.4	326.75	0.315	0.670	3.381	0.992	0.643	1.043	0.9913	0.982	14.711	0.989	0.0786	25191.6
86	2.548	464.33	1.289	7.99	632.6	327.18	0.517	0.474	2.440	1.044	0.271	1.751	0.9891	0.941	14.592	0.987	0.0596	25774.3
87	3.067	467.16	1.578	14.39	848.9	332.33	0.391	0.628	3.022	1.015	0.603	1.042	0.9902	0.959	14.582	0.988	0.0718	25923.6
88	3.228	462.18	1.756	17.46	935.2	329.42	0.352	0.664	3.244	0.995	0.635	1.046	0.9904	0.963	14.581	0.988	0.0756	25645.8
89	3.366	458.32	2.026	21.39	1035.1	327.32	0.316	0.681	3.378	0.996	0.643	1.059	0.9905	0.967	14.690	0.988	0.0788	25429.9
90	2.581	453.79	1.300	8.67	659.0	327.78	0.497	0.468	2.475	1.043	0.354	1.322	0.9916	0.990	14.719	0.989	0.0605	25170.3
91	3.104	459.83	1.607	15.38	877.6	331.73	0.378	0.618	3.070	1.011	0.617	1.001	0.9915	0.987	14.742	0.989	0.0728	25506.3
92	3.248	455.12	1.789	18.44	961.0	328.13	0.341	0.654	3.279	0.991	0.639	1.024	0.9915	0.986	14.691	0.989	0.0762	25245.3
93	3.359	455.51	2.006	21.55	1038.9	328.27	0.316	0.671	3.379	0.994	0.643	1.044	0.9914	0.985	14.640	0.989	0.0787	25267.5

- 149 -

1/2 - DESIGN ADMISSION CONFIGURATION : 1ST STAGE 13.8% , 2ND STAGE 19.5%

turbine dia= 3.00 noz thr dia, in= 0.2500
 atm= 14.23 1st stg noz area= 0.1074
 leak 0.0185 flo noz in dia= 0.8700

line number	input slice	input speed	input flow noz temp	input turb in temp	input turb out temp	input noz pos	input noz u/s press	input noz d/s press	input turb in press	input turb in press	input turb out press
1	85	9941.9	13.00	15.90	-9.00	-10	391.29	203.00	200.95	202.05	120.52
2	84	9951.5	12.00	17.30	2.00	-10	324.74	200.53	199.10	200.10	150.74
3	87	9962.2	12.70	14.30	-19.00	-10	419.16	203.30	200.90	202.04	93.64
4	53	9969.9	23.00	24.00	0.00	-30	386.69	201.58	199.63	200.56	120.04
5	54	9979.2	25.00	25.00	-3.00	-30	403.21	201.67	199.61	200.53	107.01
6	22	9982.2	14.90	16.00	-14.00	0	411.62	203.89	201.53	202.33	108.44
7	21	9982.7	14.00	17.20	-8.50	0	391.09	202.14	199.88	200.70	121.02
8	39	9991.8	21.00	21.90	-16.70	40	431.22	203.05	200.52	201.48	92.56
9	23	9992.3	15.60	16.80	-19.00	0	424.11	203.31	200.81	201.62	92.04
10	38	9994.4	22.40	23.80	-10.00	40	417.94	201.78	199.44	200.33	105.92
11	86	9994.7	12.70	14.90	-13.40	-10	405.61	202.78	200.50	201.65	108.05
12	55	9995.9	25.60	25.00	-8.00	-30	417.52	202.35	200.11	201.03	92.39
13	20	9998.9	14.00	19.10	3.00	0	329.44	201.87	200.30	201.00	151.86
14	70	10012.5	22.00	23.90	-6.90	10	411.50	202.64	200.27	201.34	108.15
15	36	10014.2	24.00	28.00	11.00	40	333.65	201.61	200.15	200.93	152.62
16	71	10016.4	21.00	22.20	-13.00	10	423.36	202.64	200.17	201.23	94.12
17	52	10021.2	20.30	23.90	9.00	-30	324.55	201.81	200.50	201.38	151.87
18	69	10027.8	22.50	25.10	-1.50	10	397.61	202.69	200.52	201.59	120.00
19	68	10028.7	22.30	27.10	10.20	10	332.18	201.73	200.30	201.21	152.02
20	37	10054.2	24.10	25.80	-3.00	40	408.01	204.25	201.94	202.90	120.10
21	79	14996.0	14.20	16.60	-22.00	-10	410.58	201.61	199.29	200.39	94.82
22	76	15003.0	14.00	19.20	6.00	-10	319.36	201.06	199.69	200.64	150.84
23	60	15011.8	29.00	32.00	16.00	10	326.24	201.02	199.67	200.54	151.10
24	13	15016.0	25.80	27.80	-1.90	0	388.25	202.76	200.62	201.36	121.23
25	12	15017.7	25.00	29.00	13.00	0	327.30	201.96	200.42	201.05	150.81
26	14	15028.3	24.80	26.00	-10.00	0	408.15	204.26	201.81	202.60	108.53
27	15	15039.0	23.00	24.10	-17.30	0	418.81	203.26	200.76	201.51	94.12
28	78	15042.8	15.00	17.30	-16.00	-10	400.88	202.21	199.90	201.00	106.53
29	63	15050.3	29.00	29.10	-15.00	10	425.05	204.26	201.78	202.87	93.14
30	61	15051.2	29.00	30.30	0.10	10	387.78	200.61	198.67	199.61	119.34
31	45	15060.5	13.00	16.80	-8.20	-30	378.75	201.40	199.55	200.39	120.13
32	28	15062.2	27.00	29.00	13.00	40	331.99	202.17	200.73	201.48	151.28
33	44	15068.2	12.00	18.10	6.00	-30	312.54	199.57	198.36	199.11	150.09
34	46	15084.1	13.00	15.80	-16.00	-30	399.77	202.73	200.58	201.53	106.74
35	77	15089.6	15.00	18.00	-10.00	-10	386.12	203.18	201.11	202.20	120.33
36	47	15098.9	13.70	15.20	-23.00	-30	412.21	202.56	200.31	201.26	93.26
37	62	15100.3	29.00	29.70	-7.00	10	408.63	202.78	200.52	201.60	107.55
38	31	15125.1	29.90	29.00	-15.80	40	422.84	201.47	199.07	199.94	93.06
39	29	15126.1	28.20	29.00	-1.00	40	389.42	201.02	198.97	199.77	121.54
40	30	15155.1	29.00	29.00	-8.10	40	413.53	203.01	200.78	201.60	107.42
41	57	20970.5	30.00	29.00	-15.00	10	417.19	202.83	200.50	201.54	93.59

2 STAGE PARTIAL ADMISSION TEST 12, 1/2 DESIGN CONFIGURATION

1/2 - DESIGN ADMISSION CONFIGURATION : 1ST STAGE 13.8% , 2ND STAGE 19.5%

turbine dia= 3.00 noz thr dia, in= 0.2500
 atm= 14.23 1st stg noz area= 0.1074
 leak 0.0185 flo noz in dia= 0.8700

line number	input slice	input speed	input flow noz temp	input turb in temp	input turb out temp	input noz pos	input noz u/s press	input noz d/s press	input turb in press	input turb in press	input turb out press
42	58	20971.4	29.20	30.00	2.00	10	387.00	202.63	200.57	201.60	120.61
43	56	20976.3	29.00	29.20	-6.50	10	403.83	202.44	200.29	201.27	106.90
44	27	20983.7	25.00	27.20	17.70	40	323.44	201.03	199.71	200.41	150.57
45	26	20987.3	25.00	25.00	-2.10	40	386.96	201.97	199.90	200.74	120.58
46	25	20992.9	24.90	23.60	-20.30	40	421.00	203.26	200.90	201.74	93.61
47	40	20997.7	15.80	18.00	-11.00	-30	389.07	200.88	198.84	199.69	106.10
48	24	20999.1	22.60	22.40	-13.00	40	404.65	201.78	199.57	200.34	106.57
49	75	21004.0	14.00	19.10	11.80	-10	319.06	202.92	201.59	202.54	151.87
50	41	21004.2	15.00	17.20	-18.80	-30	402.01	200.91	198.80	199.66	93.32
51	59	21009.3	29.00	31.30	22.00	10	326.09	202.21	200.95	201.84	151.64
52	43	21010.7	13.00	18.50	14.00	-30	309.89	200.72	199.54	200.27	151.09
53	42	21012.4	14.00	17.20	-5.00	-30	376.78	203.30	201.41	202.29	120.91
54	73	21013.2	16.10	18.00	-21.00	-10	408.22	202.23	199.88	201.00	92.64
55	74	21013.6	15.00	18.30	-6.00	-10	378.05	201.69	199.71	200.75	119.07
56	72	21017.5	17.00	19.10	-13.00	-10	397.45	203.25	201.07	202.15	106.82
57	11	21063.7	26.00	29.10	19.70	0	325.77	202.48	200.89	201.50	150.61
58	10	21074.7	27.00	28.90	3.00	0	380.05	201.43	199.33	200.04	121.23
59	8	21081.8	28.90	29.00	-5.00	0	401.56	203.30	200.86	201.61	108.09
60	7	21085.0	7.70	15.40	-15.70	0	391.79	201.60	198.29	199.07	107.94
61	9	21085.3	29.00	29.00	-14.00	0	410.97	201.01	198.49	199.27	92.37
62	83	24939.4	12.00	17.10	20.00	-10	313.36	202.10	200.88	201.82	151.54
63	82	24950.8	13.00	16.10	-1.10	-10	376.05	203.26	201.34	202.40	121.79
64	81	24967.6	13.00	16.00	-10.00	-10	391.93	202.01	199.88	200.99	106.79
65	50	24979.1	16.50	18.80	2.90	-30	374.05	202.44	200.62	201.55	119.86
66	48	24987.0	14.70	16.00	-17.00	-30	403.44	201.90	199.71	200.62	91.86
67	67	24987.3	23.60	28.50	30.00	10	312.25	199.15	197.83	198.72	150.93
68	65	24988.6	28.00	28.90	-2.00	10	404.61	204.12	201.85	202.93	108.00
69	80	24990.9	14.00	16.00	-19.00	-10	403.82	201.44	199.18	200.28	92.85
70	51	24992.6	17.10	21.30	25.90	-30	309.37	201.81	200.66	201.48	151.27
71	49	24998.5	15.30	17.00	-6.60	-30	392.01	203.57	201.58	202.49	108.00
72	33	25000.9	28.20	29.00	-2.00	40	404.21	203.12	200.91	201.79	107.53
73	32	25001.8	29.00	28.90	-13.00	40	420.72	204.06	201.62	202.52	92.76
74	34	25006.2	27.90	29.00	8.20	40	383.97	202.69	200.70	201.53	121.80
75	66	25007.9	27.00	28.50	6.00	10	386.21	202.75	200.74	201.76	119.90
76	35	25008.5	26.00	29.70	30.00	40	324.82	204.32	202.99	203.78	152.74
77	64	25026.4	29.00	28.90	-11.80	10	415.08	203.02	200.59	201.70	93.83
78	17	25070.5	19.00	21.00	-6.00	0	394.73	202.00	199.70	200.48	108.59
79	19	25072.8	15.00	20.30	21.10	0	320.34	202.39	200.97	201.63	150.63
80	18	25079.4	17.00	20.10	-1.00	0	384.21	203.06	201.00	201.76	119.25
81	16	25167.5	20.40	22.20	-16.00	0	412.58	203.31	200.91	201.71	93.26

151

1/2 - DESIGN ADMISSION CONFIGURATION : 1ST STAGE 13.8% , 2ND STAGE 19.5%

line number	noz pos	output speed	output flow noz temp R	output flow noz press psia	output flow noz inlet gamma	output turb in temp R	output turb in press psia	output turb in inlet gamma	output turb out temp R	output turb out press psia	output turb in enthalpy btu/lbm	output turb in entropy btu/#-R	output turb out enthalpy btu/lbm	output turb out enthalpy btu/lbm	output isen. sonic vel	output flow noz flowrate #/sec	output mach number	output flow noz tot press
1	-10	9941.9	472.67	405.52	1.4613	475.57	215.73	1.4321	450.67	134.75	116.17	1.41051	110.45	101.56	1096.1	0.4682	0.0462	406.16
2	-10	9951.5	471.67	338.97	1.4515	476.97	213.83	1.4316	461.67	164.97	116.54	1.41195	113.06	108.31	1094.7	0.3878	0.0457	339.48
3	-10	9962.2	472.37	433.39	1.4657	473.97	215.70	1.4324	440.67	107.87	115.76	1.40966	108.14	95.32	1095.9	0.5023	0.0464	434.08
4	-30	9969.9	482.67	400.92	1.4572	483.67	214.33	1.4305	459.67	134.27	118.25	1.41533	112.74	103.48	1107.0	0.4572	0.0461	401.54
5	-30	9979.2	484.67	417.44	1.4589	484.67	214.30	1.4304	456.67	121.24	118.51	1.41587	112.05	100.84	1109.3	0.4759	0.0462	418.09
6	0	9982.2	474.57	425.85	1.4637	475.67	216.16	1.4322	445.67	122.67	116.19	1.41042	109.25	98.94	1098.3	0.4918	0.0463	426.51
7	0	9982.7	473.67	405.32	1.4609	476.87	214.52	1.4317	451.17	135.25	116.51	1.41164	110.57	102.14	1097.1	0.4674	0.0462	405.96
8	40	9991.8	480.67	445.45	1.4643	481.57	215.23	1.4310	442.97	106.79	117.71	1.41390	108.74	96.68	1104.9	0.5120	0.0464	446.15
9	0	9992.3	475.27	438.34	1.4653	476.47	215.45	1.4319	440.67	106.27	116.40	1.41110	108.17	95.47	1099.0	0.5066	0.0464	439.03
10	40	9994.4	482.07	432.17	1.4619	483.47	214.11	1.4305	449.67	120.15	118.20	1.41530	110.28	100.36	1106.3	0.4951	0.0463	432.85
11	-10	9994.7	472.37	419.84	1.4636	474.57	215.30	1.4322	446.27	122.28	115.92	1.41013	109.40	98.74	1095.8	0.4858	0.0463	420.50
12	-30	9995.9	485.27	431.75	1.4607	484.67	214.80	1.4304	451.67	106.62	118.50	1.41569	110.95	97.33	1110.0	0.4928	0.0463	432.42
13	0	9998.9	473.67	343.67	1.4516	478.77	214.88	1.4314	462.67	166.09	117.00	1.41253	113.31	108.78	1097.0	0.3925	0.0458	344.19
14	10	10012.5	481.67	425.73	1.4611	483.57	215.04	1.4307	452.77	122.38	118.22	1.41503	111.05	100.74	1105.9	0.4876	0.0463	426.39
15	40	10014.2	483.67	347.88	1.4494	487.67	214.77	1.4300	470.67	166.85	119.27	1.41728	115.34	111.07	1107.9	0.3930	0.0458	348.41
16	10	10016.4	480.67	437.59	1.4632	481.87	214.93	1.4309	446.67	108.35	117.79	1.41416	109.65	97.18	1104.9	0.5025	0.0464	438.28
17	-30	10021.2	479.97	338.78	1.4491	483.57	215.17	1.4307	468.67	166.10	118.22	1.41498	114.84	109.88	1104.0	0.3838	0.0457	339.29
18	10	10027.8	482.17	411.84	1.4589	484.77	215.28	1.4305	458.17	134.23	118.53	1.41557	112.36	103.57	1106.4	0.4706	0.0462	412.48
19	10	10028.7	481.97	346.41	1.4497	486.77	214.99	1.4301	469.87	166.25	119.04	1.41673	115.14	110.71	1106.1	0.3920	0.0458	346.93
20	40	10054.2	483.77	422.24	1.4599	485.47	216.65	1.4306	456.67	134.33	118.69	1.41545	111.98	103.54	1108.3	0.4822	0.0463	422.90
21	-10	14996.0	473.87	424.81	1.4638	476.27	214.07	1.4317	437.67	109.05	116.36	1.41148	107.36	96.31	1097.3	0.4909	0.0463	425.48
22	-10	15003.0	473.67	333.59	1.4501	478.87	214.39	1.4313	465.67	165.07	117.03	1.41276	114.08	108.69	1097.0	0.3803	0.0457	334.10
23	10	15011.8	488.67	340.47	1.4470	491.67	214.34	1.4293	475.67	165.33	120.30	1.41952	116.62	111.80	1113.4	0.3820	0.0457	340.99
24	0	15016.0	485.47	402.48	1.4565	487.47	215.22	1.4301	457.77	135.46	119.22	1.41701	112.25	104.45	1110.0	0.4575	0.0461	403.10
25	0	15017.7	484.67	341.53	1.4482	488.67	214.97	1.4298	472.67	165.04	119.52	1.41773	115.86	110.93	1109.0	0.3850	0.0457	342.05
26	0	15028.3	484.47	422.38	1.4597	485.67	216.44	1.4305	449.67	122.76	118.75	1.41564	110.26	101.08	1109.1	0.4820	0.0463	423.04
27	0	15039.0	482.67	433.04	1.4618	483.77	215.36	1.4307	442.37	108.35	118.27	1.41502	108.56	97.51	1107.1	0.4958	0.0463	433.72
28	-10	15042.8	474.67	415.11	1.4620	476.97	214.68	1.4317	443.67	120.76	116.54	1.41164	108.75	99.02	1098.3	0.4787	0.0462	415.76
29	10	15050.3	488.67	439.28	1.4606	488.77	216.56	1.4300	444.67	107.37	119.54	1.41722	109.16	98.12	1113.7	0.4999	0.0463	439.97
30	10	15051.2	488.67	402.01	1.4555	489.97	213.37	1.4294	459.77	133.57	119.87	1.41898	112.77	104.88	1113.4	0.4553	0.0461	402.63
31	-30	15060.5	472.67	392.98	1.4594	476.47	214.20	1.4317	451.47	134.36	116.41	1.41155	110.65	101.91	1095.9	0.4529	0.0461	393.59
32	40	15062.2	486.67	346.22	1.4483	488.67	215.33	1.4299	472.67	165.51	119.52	1.41760	115.86	110.96	1111.3	0.3897	0.0457	346.74
33	-30	15068.2	471.67	326.77	1.4496	477.77	212.97	1.4313	465.67	164.32	116.76	1.41269	114.09	108.51	1094.6	0.3730	0.0456	327.27
34	-30	15084.1	472.67	414.00	1.4626	475.47	215.29	1.4321	443.67	120.97	116.15	1.41062	108.75	98.65	1096.1	0.4785	0.0462	414.65
35	-10	15089.6	474.67	400.35	1.4598	477.67	215.89	1.4318	449.67	134.56	116.70	1.41159	110.20	101.97	1098.3	0.4608	0.0462	400.97
36	-30	15098.9	473.37	426.44	1.4642	474.87	215.02	1.4321	436.67	107.49	116.00	1.41039	107.13	95.51	1096.9	0.4932	0.0463	427.11
37	10	15100.3	488.67	422.86	1.4583	489.37	215.29	1.4298	452.67	121.78	119.70	1.41798	111.03	101.83	1113.6	0.4802	0.0462	423.52
38	40	15125.1	489.57	437.07	1.4600	488.67	213.73	1.4297	443.87	107.29	119.54	1.41817	108.96	98.48	1114.6	0.4967	0.0463	437.75
39	40	15126.1	487.87	403.65	1.4559	488.67	213.60	1.4296	458.67	135.77	119.54	1.41822	112.48	105.04	1112.6	0.4577	0.0461	404.28
40	40	15155.1	488.67	427.76	1.4590	488.67	215.42	1.4299	451.57	121.65	119.52	1.41757	110.75	101.63	1113.6	0.4861	0.0463	428.42
41	10	20970.5	489.67	431.42	1.4592	488.67	215.25	1.4299	444.67	107.82	119.52	1.41763	109.16	98.40	1114.8	0.4899	0.0463	432.10

1/2 - DESIGN ADMISSION CONFIGURATION : 1ST STAGE 13.8% , 2ND STAGE 19.5%

line number	output noz pos	output speed	output flow temp noz R	output flow press noz psia	output flow inlet noz gamma	output turb in temp R	output turb in press psia	output turb in inlet gamma	output turb out temp R	output turb out press psia	output turb in enthalpy btu/lbm	output turb in entropy btu/#-R	output turb out enthalpy btu/lbm	output turb out enthalpy btu/lbm	output isen. sonic vel	output flow noz flowrate #/sec	output mach number	output flow noz tot press
42	10	20971.4	488.87	401.23	1.4553	489.67	215.32	1.4297	461.67	134.84	119.78	1.41813	113.24	104.79	1113.8	0.4543	0.0461	401.85
43	10	20976.3	488.67	418.06	1.4577	488.87	215.01	1.4298	453.17	121.13	119.58	1.41782	111.16	101.61	1113.6	0.4745	0.0462	418.71
44	40	20983.7	484.67	337.67	1.4477	486.87	214.29	1.4300	477.37	164.80	119.07	1.41703	117.06	110.56	1109.1	0.3804	0.0457	338.18
45	40	20987.3	484.67	401.19	1.4566	484.67	214.55	1.4304	457.57	134.81	118.51	1.41578	112.20	103.79	1109.3	0.4564	0.0461	401.81
46	40	20992.9	484.57	435.23	1.4614	483.27	215.55	1.4308	439.37	107.84	118.14	1.41468	107.81	97.25	1109.3	0.4974	0.0463	435.91
47	-30	20997.7	475.47	403.30	1.4600	477.67	213.50	1.4314	448.67	120.33	116.73	1.41244	110.03	99.24	1099.1	0.4639	0.0462	403.92
48	40	20999.1	482.27	418.88	1.4599	482.07	214.19	1.4308	446.67	120.80	117.85	1.41454	109.52	100.20	1106.7	0.4790	0.0462	419.53
49	-10	21004.0	473.67	333.29	1.4501	478.77	216.29	1.4316	471.47	166.10	116.98	1.41203	115.55	108.56	1097.1	0.3800	0.0457	333.79
50	-30	21004.2	474.67	416.24	1.4622	476.87	213.46	1.4315	440.87	107.55	116.52	1.41203	108.20	96.15	1098.2	0.4801	0.0463	416.89
51	10	21009.3	488.67	340.32	1.4470	490.97	215.63	1.4296	481.67	165.87	120.11	1.41869	118.14	111.53	1113.5	0.3818	0.0457	340.84
52	-30	21010.7	472.67	324.12	1.4490	478.17	214.13	1.4314	473.67	165.32	116.85	1.41248	116.11	108.61	1095.8	0.3693	0.0456	324.61
53	-30	21012.4	473.67	391.01	1.4588	476.87	216.08	1.4319	454.67	135.14	116.50	1.41109	111.46	101.88	1097.2	0.4500	0.0461	391.62
54	-10	21013.2	475.77	422.45	1.4627	477.67	214.67	1.4316	438.67	106.87	116.72	1.41202	107.65	95.98	1099.5	0.4870	0.0463	423.11
55	-10	21013.6	474.67	392.28	1.4586	477.97	214.46	1.4315	453.67	133.30	116.79	1.41226	111.22	101.98	1098.2	0.4510	0.0461	392.89
56	-10	21017.5	476.67	411.68	1.4608	478.77	215.84	1.4316	446.67	121.05	116.99	1.41219	109.51	99.30	1100.5	0.4734	0.0462	412.33
57	0	21063.7	485.67	340.00	1.4478	488.77	215.43	1.4299	479.37	164.84	119.55	1.41762	117.56	110.84	1110.2	0.3827	0.0457	340.52
58	0	21074.7	486.67	394.28	1.4550	488.57	213.91	1.4297	462.67	135.46	119.51	1.41805	113.49	104.90	1111.3	0.4471	0.0461	394.89
59	0	21081.8	488.57	415.79	1.4574	488.67	215.47	1.4299	454.67	122.32	119.52	1.41755	111.54	101.77	1113.5	0.4718	0.0462	416.44
60	0	21085.0	467.37	406.02	1.4633	475.07	212.91	1.4318	443.97	122.17	116.07	1.41126	108.82	99.17	1089.8	0.4717	0.0462	406.66
61	0	21085.3	488.67	425.20	1.4586	488.67	213.11	1.4296	445.67	106.60	119.54	1.41839	109.43	98.38	1113.5	0.4830	0.0463	425.86
62	-10	24939.4	471.67	327.59	1.4498	476.77	215.58	1.4319	479.67	165.77	116.48	1.41121	117.63	108.13	1094.8	0.3740	0.0456	328.08
63	-10	24950.8	472.67	390.28	1.4590	475.77	216.10	1.4321	458.57	136.02	116.22	1.41049	112.45	101.82	1096.1	0.4496	0.0461	390.88
64	-10	24967.6	472.67	406.16	1.4614	475.67	214.67	1.4319	449.67	121.02	116.20	1.41095	110.28	98.80	1096.0	0.4689	0.0462	406.79
65	-30	24979.1	476.17	388.28	1.4575	478.47	215.31	1.4315	462.57	134.09	116.91	1.41222	113.47	102.13	1099.9	0.4453	0.0461	388.88
66	-30	24987.0	474.37	417.67	1.4625	475.67	214.39	1.4319	442.67	106.09	116.21	1.41105	108.68	95.40	1098.0	0.4820	0.0463	418.33
67	10	24987.3	483.27	326.48	1.4465	488.17	212.51	1.4296	489.67	165.16	119.42	1.41835	120.18	111.23	1107.3	0.3676	0.0456	326.97
68	10	24988.6	487.67	418.84	1.4581	488.57	216.62	1.4301	457.67	122.23	119.48	1.41709	112.30	101.56	1112.6	0.4760	0.0462	419.50
69	-10	24990.9	473.67	418.05	1.4628	475.67	213.96	1.4318	440.67	107.08	116.21	1.41120	108.16	95.71	1097.1	0.4828	0.0463	418.70
70	-30	24992.6	476.77	323.60	1.4478	480.97	215.30	1.4311	485.57	165.50	117.55	1.41356	119.13	109.13	1100.5	0.3669	0.0456	324.09
71	-30	24998.5	474.97	406.24	1.4606	476.67	216.26	1.4320	453.07	122.23	116.45	1.41092	111.13	99.05	1098.7	0.4677	0.0462	406.87
72	40	25000.9	487.87	418.44	1.4580	488.67	215.58	1.4299	457.67	121.76	119.52	1.41751	112.30	101.63	1112.7	0.4754	0.0462	419.10
73	40	25001.8	488.67	434.95	1.4600	488.57	216.30	1.4300	446.67	106.99	119.49	1.41720	109.68	98.02	1113.7	0.4947	0.0463	435.63
74	40	25006.2	487.57	398.20	1.4553	488.67	215.35	1.4299	467.87	136.03	119.52	1.41760	114.81	104.83	1112.4	0.4513	0.0461	398.81
75	10	25007.9	486.67	400.44	1.4559	488.17	215.48	1.4300	465.67	134.13	119.39	1.41729	114.26	104.28	1111.4	0.4545	0.0461	401.06
76	40	25008.5	485.67	339.05	1.4476	489.37	217.61	1.4301	489.67	166.97	119.68	1.41716	120.16	111.04	1110.3	0.3816	0.0457	339.57
77	10	25026.4	488.67	429.31	1.4592	488.57	215.37	1.4299	447.87	108.06	119.50	1.41753	109.96	98.42	1113.6	0.4879	0.0463	429.98
78	0	25070.5	478.67	408.96	1.4597	480.67	214.32	1.4310	453.67	122.82	117.49	1.41375	111.28	100.32	1102.6	0.4690	0.0462	409.60
79	0	25072.8	474.67	334.57	1.4500	479.97	215.53	1.4313	480.77	164.86	117.30	1.41294	117.92	108.73	1098.1	0.3811	0.0457	335.08
80	0	25079.4	476.67	398.44	1.4588	479.77	215.61	1.4314	458.67	133.48	117.24	1.41281	112.49	102.25	1100.4	0.4574	0.0461	399.06
81	0	25167.5	480.07	426.81	1.4618	481.87	215.54	1.4310	443.67	107.49	117.78	1.41395	108.91	96.87	1104.2	0.4898	0.0463	427.48

153

line number	output flow para fw1	output speed para sp	output turb press ratio	output isen turb delta enthalpy	output turb c0	output turb mean blade speed	output U/CO	output turb eff temp	output flow para pred	output flow para ratio act/pred	output EFF PRED	output TEMP ACT/PRED	output gas z fact	output critical theta	output delta	output epsilon	output equiv flow lbm/s	output equiv speed rpm
1	3.273	184.14	1.601	14.61	855.4	130.13	0.152	0.392	3.419	0.957	0.444	0.882	0.9894	0.946	14.679	0.988	0.0306	10220.6
2	2.739	184.05	1.296	8.24	642.3	130.26	0.203	0.423	2.783	0.984	0.545	0.775	0.9896	0.949	14.550	0.988	0.0256	10214.9
3	3.506	184.83	2.000	20.43	1011.7	130.40	0.129	0.373	3.393	1.033	0.387	0.964	0.9892	0.943	14.677	0.987	0.0328	10259.3
4	3.244	183.11	1.596	14.77	860.2	130.50	0.152	0.373	3.414	0.950	0.443	0.843	0.9903	0.963	14.584	0.988	0.0304	10160.5
5	3.381	183.09	1.768	17.67	940.8	130.62	0.139	0.365	3.528	0.958	0.412	0.887	0.9905	0.965	14.582	0.988	0.0317	10159.1
6	3.432	184.87	1.762	17.25	929.6	130.66	0.141	0.402	3.525	0.973	0.416	0.966	0.9894	0.946	14.709	0.988	0.0321	10260.9
7	3.290	184.65	1.586	14.38	848.6	130.66	0.154	0.413	3.400	0.968	0.448	0.922	0.9896	0.949	14.597	0.988	0.0308	10248.1
8	3.610	183.91	2.015	21.03	1026.4	130.78	0.127	0.426	3.376	1.069	0.383	1.113	0.9901	0.959	14.646	0.988	0.0338	10205.7
9	3.549	184.90	2.027	20.93	1023.9	130.79	0.128	0.393	3.355	1.058	0.384	1.024	0.9895	0.948	14.660	0.988	0.0332	10262.4
10	3.516	183.60	1.782	17.84	945.3	130.82	0.138	0.444	3.529	0.996	0.411	1.080	0.9903	0.962	14.569	0.988	0.0329	10187.6
11	3.399	185.32	1.761	17.18	927.6	130.82	0.141	0.379	3.524	0.964	0.418	0.908	0.9893	0.944	14.650	0.988	0.0318	10286.1
12	3.493	183.40	2.015	21.18	1029.9	130.84	0.127	0.357	3.380	1.033	0.382	0.934	0.9904	0.965	14.616	0.988	0.0327	10176.1
13	2.764	184.58	1.294	8.21	641.3	130.88	0.204	0.449	2.774	0.996	0.547	0.820	0.9898	0.953	14.622	0.988	0.0259	10243.7
14	3.448	183.91	1.757	17.48	935.6	131.05	0.140	0.410	3.525	0.978	0.415	0.988	0.9903	0.963	14.632	0.988	0.0323	10205.0
15	2.795	183.17	1.287	8.20	640.8	131.08	0.205	0.480	2.760	1.013	0.548	0.875	0.9908	0.971	14.614	0.988	0.0262	10162.4
16	3.549	184.31	1.984	20.61	1016.0	131.10	0.129	0.395	3.415	1.039	0.387	1.019	0.9901	0.959	14.625	0.988	0.0332	10227.5
17	2.712	184.07	1.295	8.33	646.1	131.17	0.203	0.406	2.781	0.975	0.546	0.744	0.9903	0.963	14.641	0.988	0.0254	10213.8
18	3.328	183.96	1.604	14.96	865.5	131.25	0.152	0.412	3.422	0.973	0.443	0.931	0.9904	0.965	14.649	0.988	0.0312	10207.5
19	2.782	183.60	1.293	8.33	646.0	131.27	0.203	0.468	2.776	1.002	0.546	0.857	0.9907	0.969	14.629	0.988	0.0261	10186.8
20	3.391	184.31	1.613	15.15	871.0	131.60	0.151	0.443	3.432	0.988	0.442	1.004	0.9904	0.967	14.742	0.988	0.0318	10226.8
21	3.461	277.55	1.963	20.05	1002.2	196.28	0.196	0.449	3.400	1.018	0.533	0.842	0.9895	0.948	14.567	0.988	0.0324	15404.6
22	2.685	276.92	1.299	8.33	646.1	196.37	0.304	0.353	2.614	1.027	0.641	0.551	0.9898	0.953	14.588	0.988	0.0251	15368.6
23	2.733	273.46	1.296	8.49	652.3	196.49	0.301	0.433	2.610	1.047	0.640	0.676	0.9912	0.979	14.585	0.989	0.0256	15170.1
24	3.246	274.71	1.589	14.76	859.9	196.54	0.229	0.472	3.262	0.995	0.583	0.809	0.9907	0.971	14.645	0.988	0.0304	15241.5
25	2.738	274.40	1.303	8.60	656.2	196.57	0.300	0.426	2.628	1.042	0.640	0.666	0.9909	0.973	14.628	0.988	0.0257	15223.9
26	3.394	275.44	1.763	17.67	940.7	196.71	0.209	0.480	3.422	0.992	0.555	0.864	0.9905	0.967	14.728	0.988	0.0318	15283.1
27	3.502	276.18	1.988	20.76	1019.7	196.85	0.193	0.467	3.381	1.036	0.528	0.885	0.9903	0.963	14.655	0.988	0.0328	15324.8
28	3.368	278.21	1.778	17.52	936.7	196.90	0.210	0.444	3.425	0.983	0.557	0.798	0.9896	0.949	14.608	0.988	0.0315	15441.0
29	3.529	274.97	2.017	21.42	1035.7	196.99	0.190	0.484	3.354	1.052	0.523	0.926	0.9908	0.973	14.736	0.988	0.0331	15255.4
30	3.267	274.65	1.597	14.99	866.5	197.01	0.227	0.474	3.274	0.998	0.582	0.815	0.9911	0.976	14.519	0.989	0.0306	15237.0
31	3.192	278.68	1.594	14.51	852.4	197.13	0.231	0.397	3.263	0.978	0.587	0.677	0.9895	0.948	14.575	0.988	0.0299	15467.6
32	2.767	275.22	1.301	8.56	654.8	197.15	0.301	0.428	2.623	1.055	0.640	0.669	0.9908	0.973	14.652	0.988	0.0259	15269.0
33	2.647	278.45	1.296	8.24	642.6	197.23	0.307	0.324	2.604	1.017	0.642	0.505	0.9898	0.951	14.491	0.988	0.0248	15453.7
34	3.351	279.41	1.780	17.49	936.0	197.44	0.211	0.423	3.425	0.979	0.558	0.757	0.9894	0.946	14.649	0.988	0.0314	15508.7
35	3.226	278.87	1.604	14.74	859.2	197.51	0.230	0.442	3.276	0.985	0.585	0.755	0.9896	0.951	14.690	0.988	0.0302	15477.4
36	3.457	279.87	2.000	20.49	1013.0	197.63	0.195	0.433	3.373	1.025	0.532	0.813	0.9893	0.945	14.631	0.988	0.0324	15534.0
37	3.412	275.71	1.768	17.87	946.1	197.65	0.209	0.485	3.424	0.997	0.555	0.874	0.9909	0.975	14.649	0.988	0.0320	15296.4
38	3.553	276.36	1.992	21.06	1027.0	197.97	0.193	0.502	3.377	1.052	0.528	0.951	0.9909	0.973	14.544	0.989	0.0333	15332.8
39	3.276	276.38	1.573	14.50	852.1	197.99	0.232	0.487	3.236	1.012	0.588	0.828	0.9909	0.973	14.535	0.989	0.0307	15333.8
40	3.449	276.91	1.771	17.89	946.7	198.37	0.210	0.490	3.424	1.007	0.556	0.881	0.9908	0.973	14.659	0.988	0.0323	15363.2
41	3.479	383.17	1.996	21.12	1028.6	274.48	0.267	0.491	3.418	1.018	0.623	0.788	0.9908	0.973	14.647	0.988	0.0326	21258.5

line number	output flow para fw1	output speed para sp	output turb press ratio	output isen turb delta enthalpy	output turb c0	output turb mean blade speed	output U/C0	output turb eff temp	output flow para pred	output flow para ratio act/pred	output EFF PRED	output EFF ACT/PRED	output gas z fact	output critical theta	output delta	output epsilon	output equiv flow lbm/s	output equiv speed rpm
42	3.229	382.80	1.597	14.98	866.3	274.49	0.317	0.436	3.126	1.033	0.643	0.679	0.9909	0.975	14.651	0.988	0.0303	21237.0
43	3.374	383.20	1.775	17.96	948.5	274.56	0.289	0.468	3.328	1.014	0.636	0.736	0.9909	0.974	14.631	0.988	0.0316	21259.8
44	2.709	384.12	1.300	8.51	652.8	274.66	0.421	0.237	2.529	1.071	0.561	0.422	0.9907	0.969	14.581	0.988	0.0254	21312.3
45	3.239	385.06	1.592	14.72	858.7	274.70	0.320	0.428	3.115	1.040	0.643	0.666	0.9904	0.965	14.599	0.988	0.0303	21365.7
46	3.508	385.72	1.999	20.89	1022.9	274.78	0.269	0.494	3.418	1.026	0.624	0.792	0.9903	0.962	14.667	0.988	0.0329	21403.3
47	3.284	388.06	1.774	17.48	935.8	274.84	0.294	0.383	3.323	0.988	0.638	0.601	0.9897	0.951	14.527	0.988	0.0308	21537.2
48	3.396	386.31	1.773	17.65	940.2	274.86	0.292	0.472	3.324	1.022	0.637	0.741	0.9902	0.960	14.574	0.988	0.0318	21437.1
49	2.658	387.73	1.302	8.42	649.4	274.92	0.423	0.170	2.531	1.050	0.556	0.306	0.9897	0.953	14.718	0.988	0.0249	21518.2
50	3.396	388.51	1.985	20.37	1010.2	274.92	0.272	0.409	3.416	0.994	0.626	0.652	0.9896	0.949	14.525	0.988	0.0318	21562.5
51	2.713	382.98	1.300	8.58	655.4	274.99	0.420	0.229	2.529	1.073	0.563	0.407	0.9911	0.978	14.672	0.989	0.0254	21246.4
52	2.608	388.10	1.295	8.24	642.3	275.01	0.428	0.089	2.513	1.038	0.548	0.163	0.9897	0.952	14.571	0.988	0.0244	21539.0
53	3.145	388.66	1.599	14.62	855.6	275.03	0.321	0.344	3.122	1.007	0.643	0.536	0.9895	0.949	14.703	0.988	0.0294	21571.1
54	3.429	388.35	2.009	20.74	1019.2	275.04	0.270	0.437	3.417	1.003	0.625	0.699	0.9897	0.951	14.607	0.988	0.0321	21553.2
55	3.179	388.23	1.609	14.82	861.5	275.05	0.319	0.376	3.137	1.013	0.643	0.585	0.9897	0.951	14.593	0.988	0.0298	21546.6
56	3.319	387.98	1.783	17.69	941.2	275.10	0.292	0.423	3.330	0.997	0.637	0.663	0.9897	0.953	14.687	0.988	0.0311	21532.1
57	2.716	384.83	1.307	8.71	660.5	275.70	0.417	0.228	2.545	1.067	0.567	0.402	0.9908	0.973	14.659	0.988	0.0255	21350.7
58	3.195	385.11	1.579	14.61	855.4	275.85	0.322	0.412	3.097	1.032	0.643	0.641	0.9909	0.973	14.556	0.988	0.0299	21366.3
59	3.348	385.20	1.762	17.75	942.9	275.94	0.293	0.450	3.315	1.010	0.637	0.706	0.9908	0.973	14.662	0.988	0.0314	21371.3
60	3.340	390.74	1.743	16.90	920.0	275.98	0.300	0.429	3.293	1.014	0.640	0.670	0.9894	0.945	14.488	0.988	0.0313	21687.7
61	3.465	385.27	1.999	21.16	1029.4	275.99	0.268	0.478	3.418	1.014	0.624	0.766	0.9909	0.973	14.501	0.989	0.0325	21374.8
62	2.619	461.34	1.301	8.34	646.4	326.43	0.505	-0.139	2.471	1.060	0.324	-0.428	0.9895	0.949	14.669	0.988	0.0245	25605.2
63	3.138	462.04	1.589	14.40	849.2	326.58	0.385	0.262	3.041	1.032	0.610	0.429	0.9894	0.947	14.705	0.988	0.0294	25644.8
64	3.295	462.40	1.774	17.41	933.8	326.80	0.350	0.341	3.260	1.011	0.636	0.536	0.9894	0.946	14.607	0.988	0.0308	25664.7
65	3.129	461.26	1.606	14.78	860.5	326.95	0.380	0.233	3.067	1.020	0.615	0.378	0.9897	0.952	14.651	0.988	0.0293	25598.9
66	3.391	462.76	2.021	20.80	1020.8	327.05	0.320	0.362	3.373	1.005	0.643	0.563	0.9894	0.946	14.589	0.988	0.0317	25684.6
67	2.643	456.80	1.287	8.18	640.3	327.06	0.511	-0.093	2.440	1.083	0.299	-0.310	0.9909	0.972	14.460	0.989	0.0248	25343.7
68	3.359	456.64	1.772	17.92	947.5	327.08	0.345	0.401	3.263	1.029	0.638	0.629	0.9908	0.973	14.740	0.988	0.0315	25334.4
69	3.404	462.83	1.998	20.50	1013.2	327.11	0.323	0.393	3.371	1.010	0.643	0.612	0.9895	0.946	14.559	0.988	0.0319	25688.6
70	2.585	460.30	1.301	8.43	649.6	327.13	0.504	-0.188	2.473	1.045	0.330	-0.569	0.9900	0.957	14.650	0.988	0.0242	25544.0
71	3.266	462.48	1.769	17.40	933.5	327.21	0.351	0.305	3.256	1.003	0.636	0.481	0.9895	0.948	14.716	0.988	0.0306	25668.7
72	3.371	456.81	1.771	17.89	946.6	327.24	0.346	0.403	3.262	1.033	0.638	0.633	0.9908	0.973	14.669	0.988	0.0316	25344.2
73	3.496	456.88	2.022	21.47	1037.0	327.25	0.316	0.457	3.379	1.035	0.643	0.711	0.9908	0.973	14.718	0.988	0.0328	25347.8
74	3.204	456.91	1.583	14.69	857.9	327.31	0.382	0.321	3.037	1.055	0.613	0.523	0.9908	0.973	14.653	0.988	0.0300	25349.6
75	3.223	457.18	1.606	15.11	870.0	327.33	0.376	0.340	3.071	1.049	0.618	0.549	0.9908	0.972	14.662	0.988	0.0302	25364.7
76	2.683	456.63	1.303	8.64	657.7	327.34	0.498	-0.056	2.482	1.081	0.353	-0.159	0.9908	0.975	14.808	0.988	0.0251	25333.3
77	3.463	457.33	1.993	21.07	1027.3	327.57	0.319	0.452	3.376	1.026	0.643	0.704	0.9908	0.973	14.655	0.988	0.0325	25372.7
78	3.318	461.88	1.745	17.17	927.3	328.15	0.354	0.362	3.234	1.026	0.634	0.570	0.9900	0.957	14.583	0.988	0.0311	25631.8
79	2.679	462.26	1.307	8.57	655.0	328.18	0.501	-0.073	2.488	1.077	0.340	-0.214	0.9899	0.955	14.666	0.988	0.0251	25653.5
80	3.213	462.48	1.615	15.00	866.7	328.26	0.379	0.317	3.079	1.043	0.616	0.515	0.9899	0.955	14.671	0.988	0.0301	25665.7
81	3.450	463.09	2.005	20.91	1023.3	329.42	0.322	0.424	3.372	1.023	0.643	0.660	0.9901	0.959	14.667	0.988	0.0323	25697.9

- 155 -

1/4 - DESIGN ADMISSION CONFIGURATION : 1ST STAGE 6.9% , 2ND STAGE 12.9%

		turbine dia=	3.00	noz thr dia, in=	0.1719						
		atm=	14.28	1st stg noz area=	0.0537						
		leak	0.017	flo noz in dia=	0.8700						

line	input	input	input	input	input	input	input	input	input	input	input
number	slice	speed	flow noz	turb in	turb out	noz pos	noz u/s	noz d/s	turb in	turb in	turb out
			temp	temp	temp		press	press	press	press	press
=====											
1	48	9980.0	28.30	38.20	27.20	-30.00	369.41	201.48	200.27	200.90	152.15
2	51	9935.0	29.00	34.40	5.90	-30.00	458.03	202.33	200.77	201.50	93.29
3	49	9956.3	29.00	36.50	16.20	-30.00	430.15	200.16	198.70	199.37	119.71
4	50	9946.0	29.00	35.40	10.80	-30.00	446.74	200.98	199.45	200.20	107.15
5	83	9975.8	25.70	32.20	1.30	-10.00	456.88	202.10	200.72	201.52	93.62
6	82	9977.4	25.80	32.20	6.00	-10.00	445.89	201.94	200.64	201.44	106.35
7	81	9991.4	25.10	33.30	11.00	-10.00	426.75	201.47	200.30	201.01	121.16
8	80	9948.2	25.00	35.00	21.40	-10.00	370.69	200.75	199.75	200.42	150.12
9	19	9979.5	25.10	31.40	-0.90	0.00	465.88	202.35	200.46	200.98	93.81
10	18	10003.8	25.30	31.70	4.00	0.00	454.92	202.27	200.40	200.90	108.01
11	16	9986.6	25.00	34.30	20.00	0.00	379.19	202.79	201.10	201.54	151.98
12	17	9991.0	25.00	32.50	8.70	0.00	442.27	203.26	201.35	201.89	121.08
13	64	9985.3	26.00	35.60	23.00	10.00	369.86	199.73	198.62	199.24	150.09
14	65	9957.6	26.90	34.70	12.10	10.00	428.83	200.85	199.52	200.24	120.00
15	66	9947.2	26.00	33.40	6.40	10.00	447.28	202.41	201.08	201.77	107.78
16	67	9957.7	26.60	32.80	1.20	10.00	456.84	201.25	199.86	200.54	92.51
17	34	10006.7	28.00	33.30	3.00	30.00	458.55	201.74	200.22	200.84	107.49
18	35	9994.3	29.00	32.80	-2.00	30.00	469.79	202.27	200.66	201.34	93.45
19	32	10029.2	25.00	33.30	18.00	30.00	378.47	200.10	198.74	199.35	149.26
20	33	10045.8	27.00	32.90	8.00	30.00	447.61	203.45	201.92	202.60	121.06
21	42	14989.7	30.00	36.50	12.00	-30.00	448.18	202.17	200.62	201.38	107.63
22	40	14992.4	29.00	38.80	33.00	-30.00	361.14	202.91	201.65	202.33	153.50
23	41	14985.7	30.00	37.20	18.50	-30.00	427.42	200.88	199.42	200.17	119.54
24	43	14986.6	30.00	35.50	6.00	-30.00	460.63	201.94	200.41	201.12	94.13
25	72	15089.0	25.00	35.30	26.00	-10.00	363.95	200.83	199.81	200.49	152.06
26	75	15031.6	26.00	32.30	0.00	-10.00	455.72	202.60	201.20	201.97	93.02
27	74	15048.6	26.00	32.80	7.20	-10.00	442.41	202.09	200.78	201.56	106.92
28	73	15086.8	26.00	33.50	13.60	-10.00	423.07	201.17	199.93	200.64	120.85
29	10	15068.8	27.00	33.80	4.80	0.00	453.56	202.55	200.45	200.90	107.03
30	9	15052.7	27.00	35.20	11.20	0.00	441.00	203.89	201.80	202.26	120.62
31	11	15061.4	27.00	33.20	-1.90	0.00	462.47	202.08	199.99	200.48	95.01
32	8	15019.3	26.60	37.00	26.00	0.00	375.69	202.65	200.74	201.17	151.85
33	59	15047.0	27.00	33.50	0.00	10.00	453.58	201.00	199.70	200.35	93.36
34	58	15091.6	27.00	33.50	6.00	10.00	442.04	200.72	199.32	200.02	105.90
35	57	15119.7	27.00	34.70	14.20	10.00	425.38	201.00	199.71	200.37	120.80
36	56	15097.4	26.00	35.70	25.90	10.00	368.36	200.55	199.35	200.02	150.44
37	24	14946.1	24.00	32.90	20.90	30.00	379.58	203.45	202.01	202.58	150.86
38	26	14935.7	25.00	30.90	1.00	30.00	455.74	202.72	201.06	201.63	108.15
39	25	14946.6	25.00	32.00	8.00	30.00	437.51	201.44	199.82	200.37	119.54
40	27	14951.1	25.00	30.30	-5.90	30.00	465.35	201.66	199.99	200.59	92.82
41	38	21015.7	30.00	37.70	29.60	-30.00	414.93	203.80	202.35	203.14	123.61

2 STAGE PARTIAL ADMISSION TEST 13, 1/4 DESIGN CONFIGURATION

1/4 - DESIGN ADMISSION CONFIGURATION : 1ST STAGE 6.9% , 2ND STAGE 12.9%

turbine dia= 3.00 noz thr dia, in= 0.1719
 atm= 14.28 1st stg noz area= 0.0537
 leak 0.017 flo noz in dia= 0.8700

line number	input slice	input speed	input flow noz temp	input turb in temp	input turb out temp	input noz pos	input noz u/s press	input noz d/s press	input turb in press	input turb in press	input turb out press
42	36	20843.6	32.10	41.70	26.10	-30.00	438.25	202.66	201.13	201.93	108.13
43	39	21046.8	29.00	39.50	47.90	-30.00	348.82	202.27	201.11	201.80	152.83
44	37	20891.4	31.00	38.50	15.00	-30.00	451.14	200.89	199.29	200.06	92.87
45	70	21045.5	25.80	33.00	19.00	-10.00	423.49	201.97	200.70	201.43	120.40
46	71	21047.6	24.70	34.20	37.20	-10.00	359.86	200.74	199.75	200.40	151.94
47	68	20978.5	26.00	32.40	12.90	-10.00	441.22	202.80	201.40	202.16	107.60
48	69	21064.8	26.00	32.20	6.90	-10.00	449.98	201.44	200.10	200.82	94.24
49	7	21005.8	27.00	36.40	36.80	0.00	376.93	204.59	202.72	203.18	153.22
50	5	20995.8	27.00	35.30	4.00	0.00	463.72	203.45	201.22	201.66	94.04
51	4	21120.2	28.00	40.20	15.70	0.00	452.46	203.41	201.22	201.63	106.25
52	6	20990.8	28.90	38.00	20.00	0.00	434.21	202.41	200.25	200.73	120.64
53	54	21085.0	27.00	33.90	19.30	10.00	422.04	200.63	199.28	199.95	120.81
54	55	21083.4	26.00	35.90	40.00	10.00	359.23	201.27	200.15	200.81	153.14
55	52	21082.0	28.00	33.80	12.00	10.00	443.36	202.01	200.59	201.31	106.11
56	53	21067.1	28.00	33.50	5.30	10.00	451.98	201.23	199.86	200.53	93.54
57	23	20897.4	23.00	31.80	31.80	30.00	364.00	203.07	201.66	202.17	152.64
58	20	20914.2	25.00	30.70	7.00	30.00	452.42	202.67	200.94	201.48	107.40
59	21	20886.9	25.00	30.40	-0.40	30.00	464.55	202.77	200.94	201.47	94.65
60	22	20884.9	24.00	30.50	13.70	30.00	431.64	202.25	200.56	201.12	121.29
61	46	24993.6	29.00	36.90	40.70	-30.00	399.68	201.15	199.82	200.50	122.13
62	44	25009.2	30.00	36.00	21.60	-30.00	446.19	202.47	201.00	201.68	93.04
63	45	25011.7	29.80	36.20	31.50	-30.00	428.53	202.63	201.20	201.89	107.22
64	47	25003.0	28.00	37.90	59.00	-30.00	339.60	201.09	199.97	200.60	150.83
65	79	24996.6	24.00	34.40	53.40	-10.00	354.99	201.95	200.99	201.69	153.05
66	76	25027.1	26.00	32.00	12.10	-10.00	452.13	202.44	201.12	201.86	93.14
67	78	24979.7	25.00	32.30	30.00	-10.00	418.22	200.93	199.76	200.45	120.59
68	77	25007.9	25.00	32.20	20.90	-10.00	437.39	201.63	200.37	201.07	106.61
69	13	24774.0	26.00	32.50	14.30	0.00	452.83	202.84	200.73	201.28	106.59
70	12	24847.7	26.00	32.60	8.00	0.00	462.99	202.84	200.72	201.23	94.29
71	15	24737.3	25.00	34.40	47.00	0.00	369.43	202.08	200.42	200.82	151.26
72	14	24741.3	25.00	32.40	25.00	0.00	430.96	202.05	200.08	200.57	121.86
73	61	25007.3	27.00	33.80	21.00	10.00	437.80	200.95	199.56	200.27	107.57
74	60	25003.0	27.00	32.90	12.00	10.00	451.64	201.49	200.01	200.70	94.24
75	62	25017.4	27.00	34.10	29.10	10.00	423.61	202.28	201.01	201.65	121.19
76	63	24985.4	26.00	36.70	54.90	10.00	360.40	203.57	202.47	203.14	153.80
77	31	25033.2	23.00	33.00	49.40	30.00	349.73	201.03	199.82	200.38	151.51
78	30	25043.2	23.90	30.50	23.30	30.00	426.16	202.97	201.40	202.06	121.24
79	28	25049.9	24.10	29.70	5.00	30.00	464.20	203.82	202.10	202.76	93.82
80	29	25052.1	24.00	30.20	14.30	30.00	442.64	200.63	199.10	199.63	105.99

- 157 -

1/4 - DESIGN ADMISSION CONFIGURATION : 1ST STAGE 6.9% , 2ND STAGE 12.9%

line number	noz pos	output speed	output temp	output press	output inlet gamma	output turb in temp	output turb in press	output turb in inlet gamma	output turb out temp	output turb out press	output turb in enthalpy	output turb in entropy	output turb out enthalpy	output turb out enthalpy	output sonic vel	output flow noz flowrate	output mach number	output flow noz tot press
			R	psia	psia	R	psia	gamma	R	psia	btu/lbm	btu/#-R	btu/lbm	btu/lbm	ft/sec	#/sec		nozz
1	-30	9980.0	487.97	383.69	1.4532	497.87	214.86	1.4284	486.87	166.43	186.19	0.84115	183.69	176.86	1112.3	0.1966	0.0209	383.82
2	-30	9935.0	488.67	472.31	1.4651	494.07	215.41	1.4291	465.57	107.57	185.22	0.83922	178.93	162.47	1113.3	0.2465	0.0213	472.46
3	-30	9956.3	488.67	444.43	1.4613	496.17	213.31	1.4285	475.87	133.99	185.77	0.84090	181.20	170.35	1113.1	0.2307	0.0211	444.57
4	-30	9946.0	488.67	461.02	1.4635	495.07	214.10	1.4287	470.47	121.43	185.48	0.84013	179.98	167.20	1113.2	0.2401	0.0212	461.17
5	-10	9975.8	485.37	471.16	1.4662	491.87	215.40	1.4294	460.97	107.90	184.66	0.83821	177.77	162.21	1109.7	0.2468	0.0213	471.32
6	-10	9977.4	485.47	460.17	1.4646	491.87	215.32	1.4294	465.67	120.63	184.66	0.83824	178.78	166.27	1109.8	0.2405	0.0212	460.32
7	-10	9991.4	484.77	441.03	1.4622	492.97	214.93	1.4292	470.67	135.44	184.94	0.83888	179.87	169.81	1108.9	0.2298	0.0211	441.18
8	-10	9948.2	484.67	384.97	1.4543	494.67	214.37	1.4288	481.07	164.40	185.38	0.83985	182.23	175.82	1108.7	0.1981	0.0209	385.09
9	0	9979.5	484.77	480.16	1.4677	491.07	215.00	1.4295	458.77	108.09	184.45	0.83797	177.21	162.19	1109.0	0.2521	0.0213	480.32
10	0	10003.8	484.97	469.20	1.4661	491.37	214.93	1.4294	463.67	122.29	184.53	0.83814	178.25	166.64	1109.2	0.2458	0.0213	469.36
11	0	9986.6	484.67	393.47	1.4555	493.97	215.60	1.4291	479.67	166.26	185.19	0.83911	181.86	175.81	1108.8	0.2029	0.0209	393.60
12	0	9991.0	484.67	456.55	1.4644	492.17	215.90	1.4294	468.37	135.36	184.73	0.83818	179.28	169.51	1108.9	0.2387	0.0212	456.70
13	10	9985.3	485.67	384.14	1.4539	495.27	213.21	1.4286	482.67	164.37	185.54	0.84053	182.64	176.15	1109.7	0.1974	0.0209	384.26
14	10	9957.6	486.57	443.11	1.4618	494.37	214.16	1.4289	471.77	134.28	185.30	0.83979	180.16	169.95	1110.8	0.2305	0.0211	443.25
15	10	9947.2	485.67	461.56	1.4647	493.07	215.70	1.4293	466.07	122.06	184.96	0.83866	178.86	166.79	1110.0	0.2412	0.0212	461.71
16	10	9957.7	486.27	471.12	1.4658	492.47	214.48	1.4292	460.87	106.79	184.81	0.83880	177.76	161.98	1110.6	0.2465	0.0213	471.28
17	30	10006.7	487.67	472.83	1.4655	492.97	214.81	1.4292	462.67	121.77	184.94	0.83892	178.00	166.82	1112.2	0.2471	0.0213	472.99
18	30	9994.3	488.67	484.07	1.4667	492.47	215.28	1.4293	457.67	107.73	184.81	0.83853	176.94	162.26	1113.4	0.2531	0.0213	484.23
19	30	10029.2	484.67	392.75	1.4554	492.97	213.33	1.4290	477.67	163.54	184.95	0.83943	181.37	175.45	1108.7	0.2025	0.0209	392.87
20	30	10045.8	486.67	461.89	1.4644	492.57	216.54	1.4294	467.67	135.34	184.83	0.83815	179.11	169.49	1111.2	0.2411	0.0212	462.04
21	-30	14989.7	489.67	462.46	1.4634	496.17	215.28	1.4287	471.67	121.91	185.75	0.84023	180.28	167.36	1114.3	0.2406	0.0212	462.61
22	-30	14992.4	488.67	375.41	1.4518	498.47	216.27	1.4285	492.67	167.78	186.34	0.84094	185.16	177.02	1113.1	0.1918	0.0208	375.53
23	-30	14985.7	489.67	441.70	1.4606	496.87	214.08	1.4285	478.17	133.82	185.94	0.84096	181.79	170.34	1114.2	0.2289	0.0211	441.85
24	-30	14986.6	489.67	474.91	1.4651	495.17	215.05	1.4289	465.67	108.41	185.50	0.83985	178.95	163.05	1114.4	0.2476	0.0213	475.07
25	-10	15089.0	484.67	378.23	1.4534	494.97	214.43	1.4288	485.67	166.34	185.45	0.83997	183.39	176.25	1108.6	0.1943	0.0208	378.35
26	-10	15031.6	485.67	470.00	1.4659	491.97	215.86	1.4294	459.67	107.30	184.68	0.83810	177.45	161.91	1110.0	0.2460	0.0213	470.16
27	-10	15048.6	485.67	456.68	1.4640	492.47	215.45	1.4293	466.87	121.20	184.81	0.83847	179.08	166.50	1110.0	0.2385	0.0212	456.84
28	-10	15086.8	485.67	437.35	1.4613	493.17	214.56	1.4291	473.27	135.13	184.99	0.83910	180.53	169.84	1109.9	0.2275	0.0211	437.49
29	0	15068.8	486.67	467.84	1.4652	493.47	214.95	1.4291	464.47	121.31	185.07	0.83910	178.47	166.77	1111.0	0.2445	0.0212	467.99
30	0	15052.7	486.67	455.28	1.4635	494.87	216.31	1.4291	470.87	134.90	185.42	0.83928	179.92	169.87	1111.0	0.2374	0.0212	455.43
31	0	15061.4	486.67	476.75	1.4665	492.87	214.51	1.4291	457.77	109.29	184.92	0.83897	176.94	163.05	1111.1	0.2496	0.0213	476.91
32	0	15019.3	486.27	389.97	1.4545	496.67	215.23	1.4287	485.67	166.13	185.88	0.84047	183.39	176.46	1110.4	0.2005	0.0209	390.10
33	10	15047.0	486.67	467.86	1.4652	493.17	214.30	1.4291	459.67	107.64	184.99	0.83918	177.44	162.48	1111.0	0.2445	0.0212	468.01
34	10	15091.6	486.67	456.32	1.4636	493.17	213.95	1.4290	465.67	120.18	185.00	0.83931	178.79	166.56	1111.0	0.2380	0.0212	456.47
35	10	15091.6	486.67	456.32	1.4636	493.17	213.95	1.4290	465.67	120.18	185.00	0.83931	178.79	166.56	1111.0	0.2380	0.0212	456.47
36	10	15119.7	486.67	439.66	1.4613	494.37	214.32	1.4289	473.87	135.08	185.30	0.83973	180.68	170.09	1111.0	0.2285	0.0211	439.80
37	10	15097.4	485.67	382.64	1.4537	495.37	213.97	1.4287	485.57	164.72	185.56	0.84031	183.38	176.11	1109.7	0.1965	0.0209	382.77
38	30	14946.1	483.67	393.86	1.4559	492.57	216.57	1.4294	480.57	165.14	184.83	0.83813	182.10	175.12	1107.7	0.2034	0.0209	393.99
39	30	14935.7	484.67	470.02	1.4663	490.57	215.62	1.4296	460.67	122.43	184.32	0.83753	177.49	166.44	1109.0	0.2463	0.0213	470.17
40	30	14946.6	484.67	451.79	1.4637	491.67	214.38	1.4293	467.67	133.82	184.61	0.83847	179.12	169.31	1108.8	0.2360	0.0212	451.93
41	-30	21015.7	489.67	429.21	1.4589	497.37	217.03	1.4288	489.27	137.89	186.05	0.84019	184.56	170.85	1114.3	0.2218	0.0211	429.35

1/4 - DESIGN ADMISSION CONFIGURATION : 1ST STAGE 6.9% , 2ND STAGE 12.9%

line number	noz pos	output	output	output	output	output	output	output	output	output	output	output	output	output	output	output	output	output	output				
		speed	temp	press	inlet	turb in	turb in	turb in	turb out	turb out	turb in	turb in	turb out	turb out	isen.	sonic	flow	noz	mach	flow			
		R	psia	gamma	R	psia	gamma	R	psia	btu/lbm	btu/#-R	btu/lbm	btu/lbm	enthalpy	entropy	enthalpy	enthalpy	vel	flowrate	number	noz	tot	press
42	-30	20843.6	491.77	452.53	1.4613	501.37	215.81	1.4280	485.77	122.41	187.08	0.84242	183.84	168.34	1116.4	0.2344	0.0212	452.68					
43	-30	21046.8	488.67	363.10	1.4501	499.17	215.74	1.4284	507.57	167.11	186.52	0.84144	188.95	177.14	1113.0	0.1848	0.0207	363.21					
44	-30	20891.4	490.67	465.42	1.4634	498.17	213.96	1.4283	474.67	107.15	186.27	0.84160	181.23	163.24	1115.3	0.2420	0.0212	465.57					
45	-10	21045.5	485.47	437.77	1.4615	492.67	215.34	1.4293	478.67	134.68	184.86	0.83860	181.91	169.54	1109.7	0.2278	0.0211	437.91					
46	-10	21047.6	484.37	374.14	1.4529	493.87	214.35	1.4290	496.87	166.22	185.17	0.83949	186.24	175.99	1108.4	0.1920	0.0208	374.26					
47	-10	20978.5	485.67	455.50	1.4639	492.07	216.06	1.4295	472.57	121.88	184.70	0.83808	180.51	166.52	1110.0	0.2378	0.0212	455.65					
48	-10	21064.8	485.67	464.26	1.4651	491.87	214.74	1.4293	466.57	108.52	184.66	0.83843	179.17	162.54	1110.0	0.2428	0.0212	464.41					
49	0	21005.8	486.67	391.21	1.4546	496.07	217.23	1.4290	496.47	167.50	185.72	0.83952	186.13	176.25	1111.0	0.2011	0.0209	391.33					
50	0	20995.8	486.67	478.00	1.4666	494.97	215.72	1.4290	463.67	108.32	185.45	0.83953	178.44	162.89	1111.0	0.2503	0.0213	478.16					
51	0	21120.2	487.67	466.74	1.4647	499.87	215.70	1.4282	475.37	120.53	186.70	0.84177	181.23	167.61	1111.8	0.2436	0.0212	466.89					
52	0	20990.8	488.57	448.49	1.4619	497.67	214.77	1.4284	479.67	134.92	186.14	0.84109	182.16	170.62	1113.0	0.2330	0.0212	448.64					
53	10	21085.0	486.67	436.32	1.4609	493.57	213.89	1.4289	478.97	135.09	185.10	0.83951	181.98	170.00	1111.0	0.2266	0.0211	436.67					
54	10	21083.4	485.67	373.51	1.4524	495.57	214.76	1.4288	499.67	167.42	185.60	0.84013	186.94	176.54	1109.8	0.1914	0.0208	373.63					
55	10	21082.0	487.67	457.64	1.4634	493.47	215.23	1.4291	471.67	120.39	185.07	0.83901	180.30	166.50	1112.2	0.2384	0.0212	457.79					
56	10	21067.1	487.67	466.26	1.4646	493.17	214.48	1.4291	464.97	107.82	184.99	0.83912	178.78	162.53	1112.2	0.2433	0.0212	466.41					
57	30	20897.4	482.67	378.28	1.4540	491.47	216.20	1.4296	491.47	166.92	184.55	0.83775	184.86	175.26	1106.6	0.1948	0.0208	378.40					
58	30	20914.2	484.67	466.70	1.4658	490.37	215.49	1.4296	466.67	121.68	184.27	0.83748	179.02	166.24	1109.0	0.2445	0.0212	466.85					
59	30	20886.9	484.67	478.83	1.4675	490.07	215.48	1.4297	459.27	108.93	184.19	0.83735	177.32	162.28	1109.0	0.2514	0.0213	478.98					
60	30	20884.9	483.67	445.92	1.4633	490.17	215.12	1.4296	473.37	135.57	184.22	0.83752	180.55	169.28	1107.8	0.2329	0.0212	446.07					
61	-30	24993.6	488.67	413.96	1.4571	496.57	214.44	1.4286	500.37	136.41	185.86	0.84070	187.38	170.77	1113.1	0.2135	0.0210	414.10					
62	-30	25009.2	489.67	460.47	1.4631	495.67	215.62	1.4289	481.27	107.32	185.63	0.83989	182.90	162.63	1114.4	0.2395	0.0212	460.62					
63	-30	25011.7	489.47	442.81	1.4608	495.87	215.82	1.4288	491.17	121.50	185.68	0.83991	185.21	167.13	1114.1	0.2296	0.0211	442.95					
64	-30	25003.0	487.67	353.88	1.4491	497.57	214.57	1.4284	518.67	165.11	186.12	0.84111	191.78	176.58	1111.9	0.1799	0.0207	353.99					
65	-10	24996.6	483.67	369.27	1.4524	494.07	215.62	1.4291	513.07	167.33	185.22	0.83915	190.34	176.03	1107.6	0.1894	0.0208	369.39					
66	-10	25027.1	485.67	466.41	1.4654	491.67	215.77	1.4295	471.77	107.42	184.60	0.83799	180.50	161.92	1110.0	0.2440	0.0212	466.56					
67	-10	24979.7	484.67	432.50	1.4610	491.97	214.39	1.4292	489.67	134.87	184.69	0.83860	184.69	169.58	1108.8	0.2250	0.0211	432.64					
68	-10	25007.9	484.67	451.67	1.4637	491.87	215.00	1.4293	480.57	120.89	184.66	0.83834	182.54	166.37	1108.9	0.2359	0.0212	451.82					
69	0	24774.0	485.67	467.11	1.4655	492.17	215.29	1.4293	473.97	120.87	184.73	0.83839	180.88	166.39	1110.0	0.2444	0.0212	467.27					
70	0	24847.7	485.67	477.27	1.4669	492.27	215.26	1.4293	467.67	108.57	184.76	0.83844	179.45	162.56	1110.0	0.2502	0.0213	477.43					
71	0	24737.3	484.67	383.71	1.4542	494.07	214.90	1.4290	506.67	165.54	185.22	0.83940	188.73	175.81	1108.7	0.1974	0.0209	383.83					
72	0	24741.3	484.67	445.24	1.4628	492.07	214.61	1.4293	484.67	136.14	184.71	0.83857	183.41	169.83	1108.8	0.2323	0.0212	445.39					
73	10	25007.3	486.67	452.08	1.4630	493.47	214.20	1.4290	480.67	121.85	185.07	0.83936	182.56	167.01	1111.0	0.2356	0.0212	452.23					
74	10	25003.0	486.67	465.92	1.4650	492.57	214.64	1.4292	471.67	108.52	184.84	0.83879	180.46	162.68	1111.1	0.2434	0.0212	466.07					
75	10	25017.4	486.67	437.89	1.4611	493.77	215.61	1.4291	488.77	135.47	185.14	0.83901	184.46	169.87	1111.1	0.2275	0.0211	438.03					
76	10	24985.4	485.67	374.68	1.4526	496.37	217.08	1.4289	514.57	168.08	185.80	0.83971	190.72	176.46	1109.8	0.1920	0.0208	374.80					
77	30	25033.2	482.67	364.01	1.4520	492.67	214.38	1.4291	509.07	165.79	184.87	0.83893	189.34	175.63	1106.5	0.1867	0.0208	364.12					
78	30	25043.2	483.57	440.44	1.4625	490.17	216.01	1.4297	482.97	135.52	184.22	0.83721	182.99	169.14	1107.7	0.2298	0.0211	440.58					
79	30	25049.9	483.77	478.48	1.4678	489.37	216.71	1.4300	464.67	108.10	184.01	0.83660	178.70	161.66	1108.1	0.2514	0.0213	478.64					
80	30	25052.1	483.67	456.92	1.4648	489.87	213.65	1.4295	473.97	120.27	184.15	0.83788	180.88	166.04	1107.8	0.2392	0.0212	457.07					

- 159 -

line number	output flow para fwl	output speed para sp	output turb press ratio	output isen turb delta enthalpy	output turb c0	output turb mean blade speed	output U/CO	output turb eff temp	output flow para pred	output flow para ratio act/pred	output EFF PRED	output EFF ACT/PRED	output EFF TEMP	output gas z fact	output critical theta	output delta	output epsilon	output equiv flow lbm/s	output equiv speed rpm
1	2.824	180.66	1.291	9.33	683.8	130.63	0.191	0.268	2.781	1.015	0.525	0.510	0.9918	0.992	14.621	0.989	0.0132	10020.5	
2	3.517	180.54	2.003	22.75	1067.5	130.04	0.122	0.276	3.408	1.032	0.368	0.750	0.9914	0.984	14.658	0.989	0.0165	10014.6	
3	3.332	180.54	1.592	15.41	878.6	130.32	0.148	0.296	3.411	0.977	0.435	0.680	0.9917	0.988	14.515	0.989	0.0156	10014.3	
4	3.451	180.55	1.763	18.28	956.9	130.18	0.136	0.301	3.531	0.977	0.405	0.742	0.9915	0.986	14.569	0.989	0.0162	10015.3	
5	3.514	181.68	1.996	22.45	1060.4	130.57	0.123	0.307	3.410	1.031	0.372	0.825	0.9912	0.980	14.657	0.989	0.0165	10078.9	
6	3.426	181.71	1.785	18.39	959.7	130.59	0.136	0.320	3.532	0.970	0.405	0.789	0.9912	0.980	14.651	0.989	0.0161	10080.5	
7	3.284	181.76	1.587	15.13	870.5	130.78	0.150	0.335	3.404	0.965	0.440	0.762	0.9913	0.982	14.625	0.989	0.0154	10083.0	
8	2.843	180.67	1.304	9.55	691.8	130.21	0.188	0.329	2.819	1.008	0.520	0.633	0.9915	0.985	14.587	0.989	0.0133	10021.7	
9	3.594	181.90	1.989	22.26	1055.9	130.62	0.124	0.325	3.418	1.051	0.373	0.872	0.9911	0.978	14.630	0.989	0.0168	10091.1	
10	3.506	182.29	1.758	17.89	946.5	130.94	0.138	0.351	3.527	0.994	0.411	0.854	0.9911	0.979	14.625	0.989	0.0164	10112.4	
11	2.893	181.49	1.297	9.38	685.5	130.71	0.191	0.355	2.795	1.035	0.524	0.677	0.9914	0.984	14.671	0.989	0.0136	10067.7	
12	3.392	181.90	1.595	15.22	873.2	130.77	0.150	0.358	3.414	0.994	0.439	0.816	0.9912	0.980	14.691	0.989	0.0159	10091.1	
13	2.849	181.23	1.297	9.39	685.7	130.70	0.191	0.308	2.797	1.019	0.524	0.588	0.9916	0.987	14.508	0.989	0.0134	10052.8	
14	3.310	180.89	1.595	15.35	876.8	130.34	0.149	0.335	3.414	0.970	0.436	0.768	0.9915	0.985	14.573	0.989	0.0155	10034.3	
15	3.435	180.94	1.767	18.17	954.0	130.20	0.136	0.336	3.531	0.973	0.406	0.826	0.9913	0.982	14.678	0.989	0.0161	10037.4	
16	3.527	181.24	2.009	22.84	1069.5	130.34	0.122	0.309	3.397	1.038	0.368	0.838	0.9913	0.981	14.595	0.989	0.0165	10054.3	
17	3.532	182.04	1.764	18.12	952.7	130.98	0.137	0.383	3.529	1.001	0.409	0.936	0.9913	0.982	14.617	0.989	0.0166	10098.5	
18	3.609	181.91	1.998	22.55	1062.8	130.82	0.123	0.349	3.407	1.059	0.372	0.939	0.9912	0.981	14.649	0.989	0.0169	10091.2	
19	2.915	182.45	1.304	9.50	689.7	131.27	0.190	0.376	2.814	1.036	0.523	0.719	0.9914	0.982	14.516	0.989	0.0137	10121.2	
20	3.418	182.83	1.600	15.34	876.5	131.49	0.150	0.373	3.419	1.000	0.439	0.849	0.9912	0.981	14.735	0.989	0.0160	10142.2	
21	3.443	271.81	1.766	18.40	959.9	196.20	0.204	0.298	3.427	1.005	0.548	0.543	0.9916	0.988	14.649	0.989	0.0161	15077.0	
22	2.738	271.23	1.289	9.32	683.3	196.24	0.287	0.126	2.590	1.057	0.635	0.199	0.9918	0.993	14.716	0.989	0.0128	15043.9	
23	3.296	271.55	1.600	15.60	883.9	196.15	0.222	0.266	3.282	1.004	0.574	0.463	0.9917	0.990	14.567	0.989	0.0155	15062.0	
24	3.544	272.03	1.984	22.45	1060.4	196.16	0.185	0.292	3.381	1.048	0.514	0.569	0.9915	0.986	14.633	0.989	0.0166	15089.5	
25	2.788	273.94	1.289	9.20	678.9	197.50	0.291	0.224	2.587	1.077	0.637	0.352	0.9915	0.986	14.591	0.989	0.0131	15195.7	
26	3.497	273.73	2.012	22.76	1067.8	196.75	0.184	0.318	3.357	1.041	0.512	0.620	0.9912	0.980	14.689	0.989	0.0164	15185.3	
27	3.397	273.90	1.778	18.31	957.5	196.97	0.206	0.313	3.430	0.991	0.550	0.569	0.9912	0.981	14.660	0.989	0.0159	15194.6	
28	3.257	274.40	1.588	15.15	871.2	197.47	0.227	0.294	3.261	0.999	0.581	0.507	0.9913	0.982	14.600	0.989	0.0153	15222.0	
29	3.495	273.99	1.772	18.29	957.2	197.24	0.206	0.361	3.427	1.020	0.551	0.655	0.9913	0.983	14.627	0.989	0.0164	15199.1	
30	3.377	273.31	1.603	15.55	882.4	197.02	0.223	0.353	3.284	1.028	0.576	0.613	0.9914	0.986	14.719	0.989	0.0158	15160.7	
31	3.572	274.03	1.963	21.87	1046.6	197.14	0.188	0.365	3.398	1.051	0.520	0.702	0.9913	0.982	14.597	0.989	0.0167	15201.1	
32	2.872	272.21	1.296	9.42	687.0	196.59	0.286	0.265	2.609	1.101	0.635	0.417	0.9917	0.989	14.646	0.989	0.0135	15098.9	
33	3.505	273.68	1.991	22.51	1061.8	196.95	0.185	0.335	3.376	1.038	0.514	0.652	0.9913	0.982	14.583	0.989	0.0164	15181.8	
34	3.417	274.49	1.780	18.43	960.8	197.53	0.206	0.337	3.430	0.996	0.550	0.613	0.9914	0.982	14.558	0.989	0.0160	15226.8	
35	3.279	274.67	1.587	15.21	872.7	197.90	0.227	0.304	3.259	1.006	0.581	0.523	0.9915	0.985	14.583	0.989	0.0154	15236.1	
36	2.828	273.99	1.299	9.45	687.9	197.61	0.287	0.231	2.618	1.080	0.635	0.363	0.9916	0.987	14.559	0.989	0.0133	15197.9	
37	2.882	272.01	1.311	9.71	697.4	195.63	0.281	0.281	2.658	1.085	0.632	0.445	0.9912	0.981	14.737	0.989	0.0135	15089.5	
38	3.500	272.37	1.761	17.88	946.3	195.49	0.207	0.382	3.425	1.022	0.551	0.693	0.9910	0.977	14.672	0.989	0.0164	15110.6	
39	3.376	272.27	1.602	15.30	875.3	195.64	0.224	0.359	3.284	1.028	0.577	0.622	0.9912	0.979	14.587	0.989	0.0158	15104.2	
40	3.593	272.82	2.003	22.53	1062.3	195.70	0.184	0.364	3.365	1.068	0.512	0.712	0.9910	0.976	14.601	0.989	0.0168	15135.7	
41	3.153	380.62	1.574	15.20	872.6	275.07	0.315	0.098	3.093	1.019	0.643	0.153	0.9917	0.991	14.768	0.989	0.0148	21111.8	

- 160 -

NASA CR-179548
RI/RD 86-214

line number	output flow para fwl	output speed para sp	output turb press ratio	output isen turb delta enthalpy	output turb c0	output turb mean blade speed	output U/C0	output turb eff temp	output flow para pred	output flow para ratio act/pred	output EFF PRED	output EFF TEMP ACT/PRED	output gas critical z fact	output theta	output delta	output epsilon	output equiv flow lbm/s	output equiv speed rpm
42	3.364	376.00	1.763	18.74	968.8	272.82	0.282	0.173	3.324	1.012	0.632	0.273	0.9921	0.999	14.685	0.989	0.0158	20853.0
43	2.647	380.50	1.291	9.38	685.5	275.48	0.402	-0.259	2.508	1.056	0.590	-0.439	0.9919	0.995	14.680	0.989	0.0124	21103.9
44	3.492	378.07	1.997	23.04	1074.1	273.45	0.255	0.219	3.419	1.021	0.612	0.357	0.9918	0.993	14.559	0.989	0.0164	20969.7
45	3.247	382.98	1.599	15.32	875.9	275.46	0.315	0.193	3.128	1.038	0.643	0.300	0.9913	0.981	14.653	0.989	0.0152	21245.2
46	2.754	382.55	1.290	9.18	678.1	275.49	0.406	-0.116	2.502	1.100	0.584	-0.199	0.9914	0.984	14.586	0.989	0.0129	21220.7
47	3.377	381.99	1.773	18.18	954.3	274.59	0.288	0.231	3.327	1.015	0.635	0.363	0.9912	0.980	14.702	0.989	0.0158	21190.8
48	3.468	383.64	1.979	22.12	1052.6	275.72	0.262	0.248	3.417	1.015	0.619	0.401	0.9912	0.980	14.612	0.989	0.0163	21282.4
49	2.852	380.94	1.297	9.47	688.7	274.95	0.399	-0.043	2.523	1.131	0.593	-0.073	0.9915	0.988	14.782	0.989	0.0134	21130.3
50	3.570	381.18	1.992	22.56	1063.0	274.81	0.259	0.310	3.418	1.044	0.616	0.504	0.9915	0.986	14.679	0.989	0.0167	21144.3
51	3.492	381.56	1.790	19.09	977.8	276.44	0.283	0.286	3.341	1.045	0.633	0.452	0.9919	0.996	14.678	0.989	0.0164	21162.2
52	3.348	380.06	1.592	15.52	881.6	274.75	0.312	0.257	3.121	1.073	0.642	0.400	0.9918	0.992	14.614	0.989	0.0157	21080.3
53	3.256	383.35	1.583	15.09	869.5	275.98	0.317	0.207	3.105	1.049	0.643	0.322	0.9914	0.983	14.555	0.989	0.0153	21265.1
54	2.744	382.54	1.283	9.06	673.8	275.96	0.410	-0.147	2.485	1.104	0.579	-0.255	0.9916	0.987	14.613	0.989	0.0129	21219.3
55	3.404	383.33	1.788	18.56	964.3	275.94	0.286	0.257	3.338	1.020	0.635	0.404	0.9913	0.983	14.646	0.989	0.0160	21264.3
56	3.485	383.18	1.989	22.46	1060.6	275.75	0.260	0.277	3.418	1.020	0.617	0.448	0.9913	0.982	14.594	0.989	0.0163	21255.9
57	2.762	380.75	1.295	9.29	682.0	273.53	0.401	-0.034	2.518	1.097	0.591	-0.057	0.9911	0.979	14.711	0.989	0.0129	21122.2
58	3.474	381.48	1.771	18.03	950.2	273.75	0.288	0.291	3.326	1.045	0.636	0.458	0.9910	0.977	14.663	0.989	0.0163	21163.5
59	3.571	381.10	1.978	21.92	1047.7	273.39	0.261	0.314	3.418	1.045	0.618	0.507	0.9910	0.976	14.663	0.989	0.0167	21142.6
60	3.316	381.02	1.587	14.95	865.2	273.36	0.316	0.246	3.112	1.065	0.643	0.382	0.9910	0.976	14.638	0.989	0.0155	21138.3
61	3.068	453.03	1.572	15.09	869.5	327.14	0.376	-0.101	3.023	1.015	0.618	-0.163	0.9917	0.989	14.592	0.989	0.0144	25128.7
62	3.420	453.73	2.009	23.00	1073.3	327.35	0.305	0.119	3.381	1.012	0.641	0.185	0.9915	0.987	14.672	0.989	0.0160	25167.8
63	3.276	453.68	1.776	18.54	963.7	327.38	0.340	0.025	3.269	1.002	0.640	0.039	0.9916	0.988	14.686	0.989	0.0154	25165.1
64	2.586	452.75	1.300	9.53	691.1	327.26	0.474	-0.594	2.476	1.045	0.436	-1.360	0.9918	0.991	14.600	0.989	0.0121	25112.2
65	2.701	454.23	1.289	9.18	678.2	327.18	0.482	-0.558	2.447	1.104	0.408	-1.367	0.9914	0.984	14.672	0.989	0.0127	25197.0
66	3.468	455.90	2.009	22.68	1065.8	327.58	0.307	0.181	3.379	1.026	0.642	0.282	0.9911	0.979	14.682	0.989	0.0163	25291.0
67	3.220	454.89	1.590	15.10	869.7	326.96	0.376	-0.000	3.048	1.056	0.619	-0.000	0.9912	0.980	14.588	0.989	0.0151	25235.2
68	3.366	455.45	1.778	18.28	956.9	327.33	0.342	0.116	3.270	1.029	0.639	0.181	0.9912	0.980	14.630	0.989	0.0158	25266.3
69	3.483	451.06	1.781	18.35	958.6	324.27	0.338	0.210	3.276	1.063	0.640	0.328	0.9912	0.980	14.649	0.989	0.0163	25022.1
70	3.566	452.35	1.983	22.20	1054.4	325.23	0.308	0.239	3.379	1.056	0.642	0.373	0.9912	0.980	14.647	0.989	0.0167	25093.9
71	2.824	449.52	1.298	9.41	686.4	323.79	0.472	-0.373	2.475	1.141	0.442	-0.844	0.9914	0.984	14.623	0.989	0.0132	24935.6
72	3.320	450.51	1.576	14.88	863.4	323.84	0.375	0.087	3.031	1.095	0.619	0.141	0.9912	0.980	14.603	0.989	0.0156	24991.7
73	3.379	454.70	1.758	18.06	951.2	327.32	0.344	0.139	3.252	1.039	0.638	0.218	0.9914	0.983	14.575	0.989	0.0158	25223.5
74	3.481	455.04	1.978	22.16	1053.5	327.26	0.311	0.198	3.375	1.031	0.642	0.308	0.9913	0.981	14.605	0.989	0.0163	25242.9
75	3.243	454.75	1.592	15.27	874.4	327.45	0.374	0.045	3.051	1.063	0.620	0.072	0.9914	0.984	14.671	0.989	0.0152	25225.8
76	2.726	452.98	1.292	9.34	684.0	327.03	0.478	-0.527	2.456	1.110	0.422	-1.247	0.9916	0.989	14.772	0.989	0.0128	25125.6
77	2.673	455.54	1.293	9.24	680.1	327.66	0.482	-0.484	2.458	1.088	0.410	-1.181	0.9913	0.981	14.588	0.989	0.0125	25270.7
78	3.258	456.89	1.594	15.08	869.0	327.79	0.377	0.082	3.053	1.067	0.618	0.132	0.9910	0.976	14.698	0.988	0.0153	25347.1
79	3.550	457.38	2.005	22.35	1058.0	327.88	0.310	0.238	3.377	1.051	0.642	0.370	0.9909	0.975	14.746	0.988	0.0166	25375.2
80	3.427	457.19	1.776	18.12	952.5	327.91	0.344	0.180	3.267	1.049	0.638	0.283	0.9910	0.976	14.538	0.989	0.0161	25364.0

- 161 -



Report Documentation Page

1. Report No. CR-179548		2. Government Accession No.		3. Recipient's Catalog No.	
4. Title and Subtitle Design and Experimental Performance of a Two Stage Partial Admission Turbine			5. Report Date 14 December 1992		
			6. Performing Organization Code		
7. Author(s) R.F.Sutton, J.L.Boynton, and R.A.Akian			8. Performing Organization Report No. RI/RD92-214		
			10. Work Unit No. TASK B.1 / B.4		
9. Performing Organization Name and Address ROCKWELL INTERNATIONAL Rocketdyne Division 6633 Canoga Avenue Canoga Park, California 91303			11. Contract or Grant No. NAS 3-23773		
			13. Type of Report and Period Covered Final Report; Dec 84 to Jun 86		
12. Sponsoring Agency Name and Address National Aeronautic Space Administration-Lewis Research Center Space Vehicle Propulsion Branch 21000 Brookpark Road Cleveland, Ohio 44135			14. Sponsoring Agency Code		
			15. Supplementary Notes Project Manager, G. Paul Richter, NASA Lewis Research Center, Cleveland, Ohio		
16. Abstract <p>A three-inch mean diameter, two-stage turbine with partial admission in each stage was experimentally investigated over a range of admissions and angular orientations of admission arcs. Three configurations were tested in which first stage admission varied from 37.4 percent (10 of 29 passages open, 5 per side) to 6.9 percent (2 open, 1 per side). Corresponding second stage admissions were 45.2 percent (14 of 31 passages open, 7 per side) and 12.9 percent (4 open, 2 per side). Angular positions of the second stage admission arcs with respect to the first stage varied over a range of 70 degrees.</p> <p>Design and off-design efficiency and flow characteristics for the three configurations are presented. The results indicated that peak efficiency and the corresponding isentropic velocity ratio decreased as the arcs of admission were decreased. Both efficiency and flow characteristics were sensitive to the second stage nozzle orientation angles.</p>					
17. Key Words (Suggested by Author(s)) Turbine Performance Two-Stage Partial Admission Turbine Impulse Turbine			18. Distribution Statement Unclassified - Unlimited		
19. Security Classif. (of this report) Unclassified		20. Security Classif. (of this page) Unclassified		21. No. of Pages 161	22. Price