

SPACE STATION FREEDOM SOLAR ARRAY TENSION MECHANISM DEVELOPMENT

Curtis Allmon and Bert Haugen
Lockheed Missiles & Space Company
Sunnyvale, California

Abstract

The tension mechanism is used to apply a tension force to the Space Station *Freedom* Solar Array Blanket. This tension is necessary to meet the deployed frequency requirement of the array as well as maintain flatness of the flexible substrate solar cell blanket. The mechanism underwent a series of design iterations before arriving at the final design. This paper discusses the design and testing of the mechanism.

Introduction and Requirements

Tension mechanisms are mounted to the containment box base of the Space Station solar array in two locations. The internal torque developed by two power springs as they wrap around an arbor is transferred to a cable which is wound on a spiral reel (Figure 1). The cable is attached to a tension distribution bar, which in turn transfers the tension to the solar cell blanket. In order to meet the overall system frequency requirement, the tension mechanism is required to provide an output force of 166.8 ± 44.5 N (37.5 ± 10 lbs). This force range must be maintained over a 71 cm (28 in.) stroke for 35 blanket deployment cycles and over a 15.2 cm (6 in.) stroke for 88,000 thermally induced cycles. Qualification testing required additional margin for twice the life cycles plus acceptance test cycles.

Design History

Negator Spring

The original design used negator springs to obtain the required force. Three springs were connected to a central hub which rotated during cable pay-out, reeling in the springs and producing the required force. The advantage of this design over others was that it produced a near constant force without requiring a spiral cable reel to compensate for variations in torque. This design was capable of meeting the output force requirements based on analysis and test; however, once the large number of cycles required to meet thermal cycling over 15 years of operational life was identified, this design was not capable of meeting fatigue requirements within the existing weight and envelope constraints.

Power Spring

The next design considered was a power spring design. The power spring used a strip of Elgiloy 3.8 cm (1.5 in.) wide, and .08 cm (0.032 in.) thick. The spring was wrapped inside a 15.2 cm (6 in.) diameter housing with one end attached to the housing and the other end to an arbor. The housing was attached to a helical reel and rotated on a bushing with respect to the arbor. The helical reel offset the spring rate as the cable payed-out in an effort to maintain a

near constant force. Development testing showed the average force to be within the acceptable range; however, with hysteresis, the force exceeded the specified range. This hysteresis caused the torque developed during cable pay-out to be significantly greater than the torque developed during cable pay-in. Some hysteresis was expected but not to the magnitude found during testing.

Power Spring (Bearings)

At this point, analysis and test suggested a major contributor to the hysteresis was the friction produced from the bushings. It was expected that by replacing the bushings with ball bearings the friction, thus hysteresis, would be reduced. This change, along with several other changes made to meet revised force and stroke requirements, were then incorporated into the design. The spring material, as well, was changed from Elgiloy to stainless steel. This was done originally to reduce cost and improve material availability; however, testing performed by Vulcan Spring showed that the stainless steel also out performed Elgiloy in cycles to failure.

A new unit was then built and tested. The results from testing showed that the hysteresis had not been significantly reduced and the loads still exceeded the specified range. This led to the conclusion that the power spring itself was the main source of hysteresis overwhelming all other sources. At this point an effort to reduce spring hysteresis, by providing oil lubrication or by co-wrapping Teflon material with the springs, was attempted with only very minor improvements. In parallel, the deployed frequency requirement was revisited. It was found that using an "average" force from the hysteresis curve was acceptable and that the tension mechanism output was within acceptable limits.

A life-cycle test was then initiated on the mechanism. As cycling continued through the first several thousand cycles, the hysteresis gradually began to increase. At the same time, a pile of metallic powder began to form beneath the mechanism. The cycling continued through 26,000 cycles at which point it was stopped due to the increased hysteresis. Examination of the mechanism revealed that the springs had large patterns of wear which had produced the debris. These wear patterns on the springs were a result of the spring rubbing on itself as it was cycled (many layers are formed as the springs are wrapped inside the 19 cm (7.5 in.) diameter housing).

The solution to this problem was to add lubrication to the springs. All springs previously tested had been unlubricated. A separate wear test was initiated with the purpose of selecting the most appropriate lubrication for the spring.

Power Spring (Lubricated)

As a result of the wear test, it was decided that the springs would be coated with an unburnished impinged Molydisulfide (MoS_2) and a light coat of Braycote 815Z oil. This combination was added to two new springs which were inserted into the existing mechanism for further testing. Testing showed that the output force was within the acceptable range and the hysteresis remained constant throughout the required 176,000 cycles with no signs of adverse wear.

Special Testing

Wear Test

A coupon wear test fixture was designed to test spring coupons coated with various lubricants by simulating the load and motion seen by the actual spring. These coupons were cut

out of the actual mechanism spring material and were stacked three high with the top and bottom coupons fixed and the middle coupon attached to a linear motion device. To simulate the force that occurs between spring layers in the actual mechanism, compression springs were used to apply a normal force to each coupon stack. A load cell was part of the driving arm of the linear motion device and was used to measure the force required to pull the middle coupons. Preliminary testing was performed to calibrate the normal force by reproducing the wear that occurred during life cycling. Two test runs, six coupon sets each, were made for over 200,000 cycles each.

The selection of coatings or lubricants to be tested were based on the coating/lubricant's successful history in space applications, its ability to be applied to the 6.1 m (20 ft) spring, and its availability. In addition, the following considerations applied to specific coupons:

- Bare 301 was tested as a baseline to which other samples could be compared.
- Bare Elgiloy was tested to investigate if the composition of the base metal significantly effected the performance.
- Braycote 815Z oil was used on various coupons due to its extremely low volatility, easily controlled application, and successful history on bearings.
- A black oxide coating was investigated primarily as a controlled surface finish that would potentially provide better adhesion for the oil.
- Various forms of MoS₂ were tested due to the potential advantages of a dry lubricant.
- Braycote 815Z oil in conjunction with impinged MoS₂ was investigated for their combined effect.
- Braycote 600 was tested as a grease alternative.

Each coupon set was cycled under both ambient conditions and a nitrogen purge. The nitrogen purge was used to minimize humidity effects on the MoS₂. All coupons were life cycled; after which, a select few underwent a cold test to demonstrate the oil's performance in a cold environment. Figure 2 shows a plot of load vs. cycles for 6 sets of coupons.

It became evident after cycling all the coupons that those coated with even small amounts of oil performed the best. Further testing revealed that the coupons coated with oil and the unburnished impinged MoS₂ performed the best of any combination tested. Other interesting points observed from the test include:

- The unburnished MoS₂ coupons outperformed those that had been burnished.
- The heat cured MoS₂ coupons outperformed those that had been air dried.

The cold test was performed by cooling the coupons with liquid nitrogen. Thermocouples were strategically placed on the coupons to monitor the temperature. The low end of the temperature range of the tension mechanism in its operational environment was predicted to be -56.7°C (-70°F); however, the detailed thermal model of the mechanism predicted the low extreme of the spring to be -26.1°C (-15°F).

In order to get a conservative range of data, the temperature of the spring was taken below -73.3°C (-100°F) during the test runs. Results from the tests were recorded on a strip chart, plotting force and temperature as a function of time (Figure 3). These plots revealed that the force necessary to pull the middle coupon remained constant until the temperature had reached -28.9°C (-20°F), at which time the force began to increase slightly. The force didn't increase significantly until the temperature had dropped to approximately -51.1°C (-60°F). The data also indicated that the force returns to its initial range after exposure to extreme temperatures. This test confirmed that the lubricated spring would not be affected by the cold temperatures of the Space Station environment.

Life Test

The life test was performed by placing the mechanism on the fixture shown in Figure 4 and cycling it for 176,000 cycles. The output force of the mechanism was monitored continuously using a strip chart, and after every 5,000 cycles, a full functional test was run. The results showed that, after an initial break-in of several hundred cycles, the mechanisms output force remained relatively constant for the entire 176,000 cycles without showing signs of wear. Figure 5 shows an example of a test run made late in the life cycle test. The top line is the force during cable pay-out over a 71 cm (28 in.) stroke and the bottom line is cable pay-in over a 71 cm (28 in.) stroke.

This test proved that the tension mechanism will adequately meet all output force requirements. It also revealed that each mechanism will need to be broken in by cycling it several hundred times and that the amount of oil applied to each spring needs to be held to a minimum to prevent oil migration out of the mechanism housing.

Conclusion

The development of the Space Station Solar Array Tension Mechanism has been completed revealing the following lessons: 1) A power spring design provided the best weight and envelope for the required tension range, 2) Inherent hysteresis in the power springs is significant and only marginally affected by lubrication, 3) Wear in the power springs requires the use of a lubricant, and 4) A combination of MoS₂ and Braycote 815 Z oil provided the best performance of the options tested for this design. The Tension Mechanism now awaits qualification testing (including 176,000 cycles under full thermal vacuum conditions) scheduled for the second quarter of 1994.

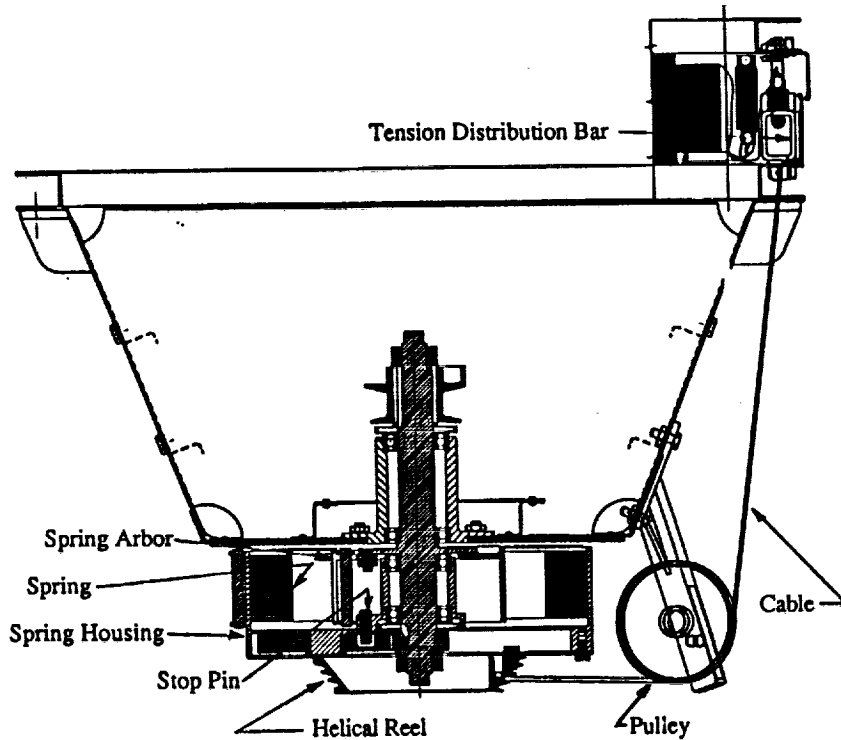

Figure 1: Cross-Sectional View of Tension Mechanism

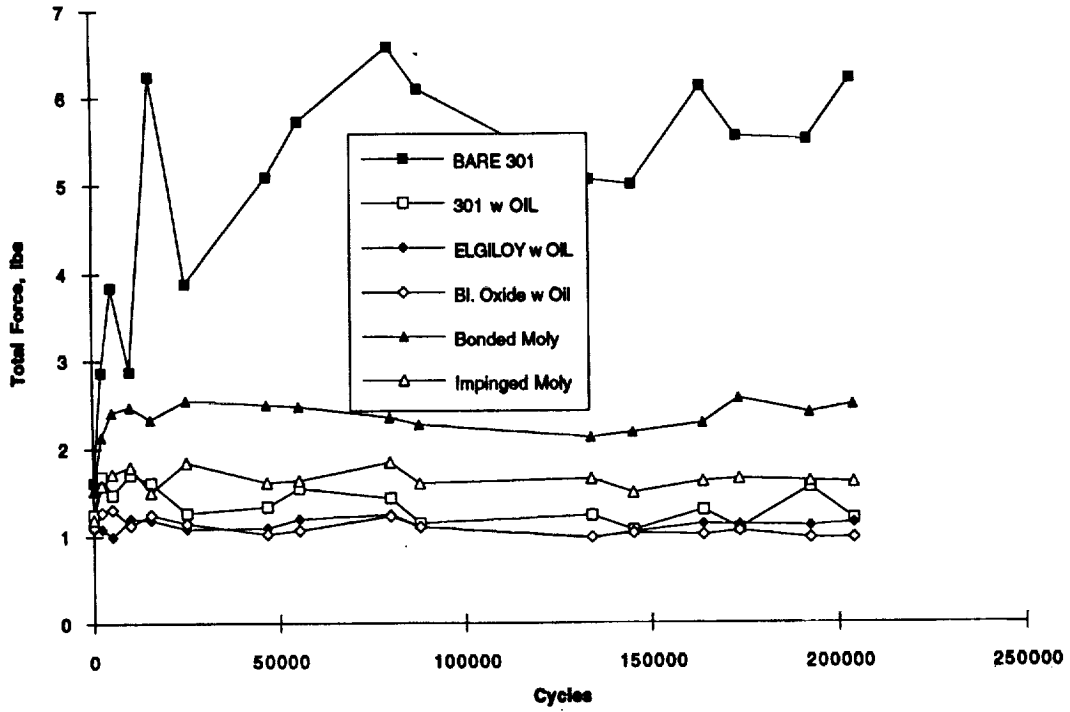

Figure 2: Representative Plot of Force vs Time for 6 coupon sets.

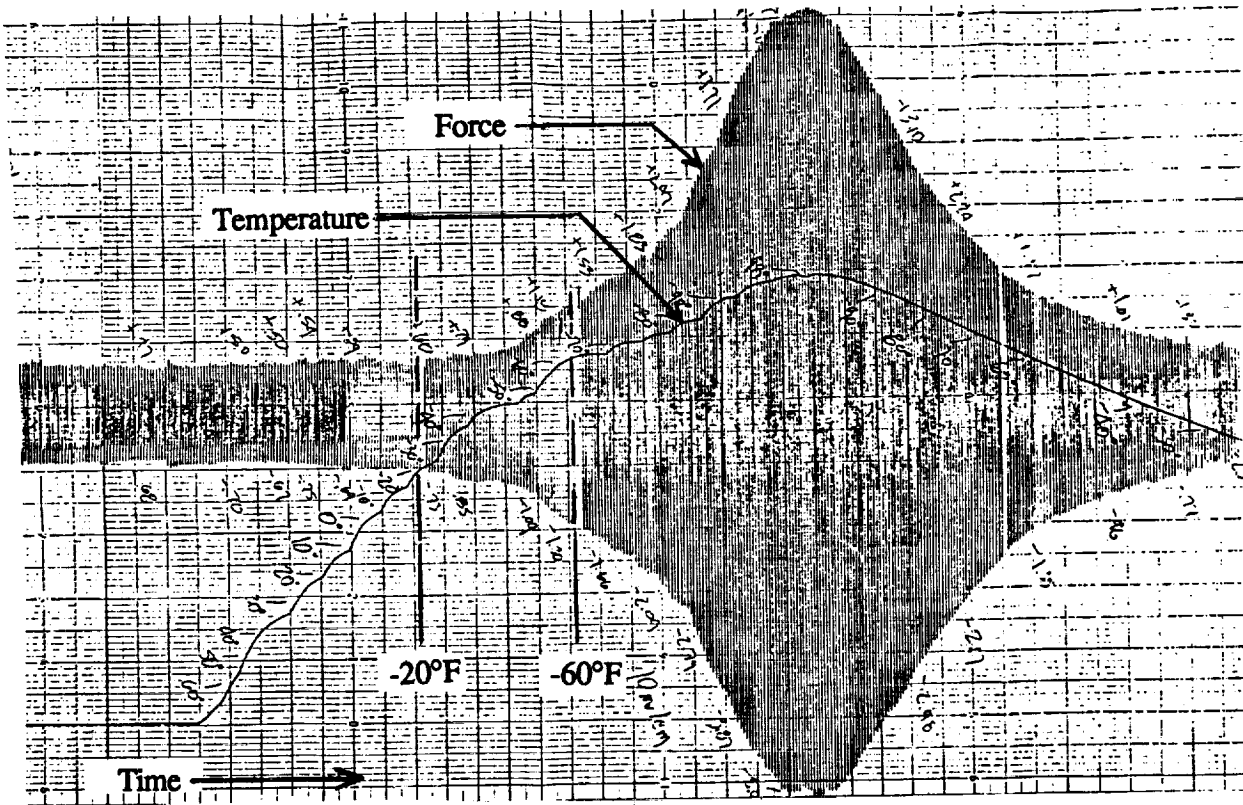

Figure 3: Cold Test Data

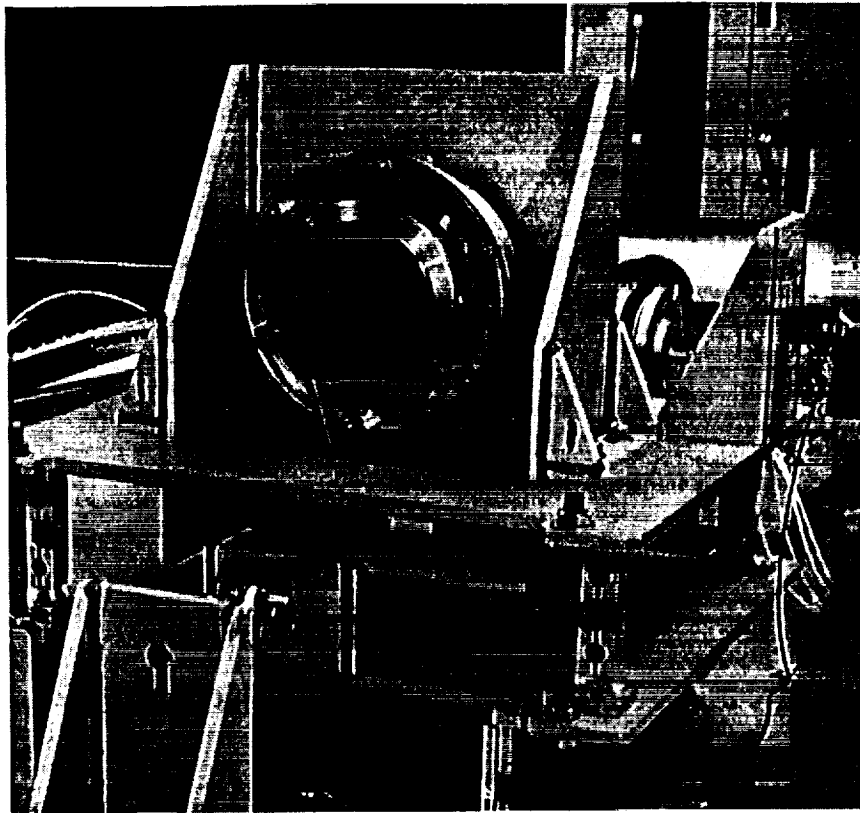

Figure 4: Life-Cycle Test Fixture

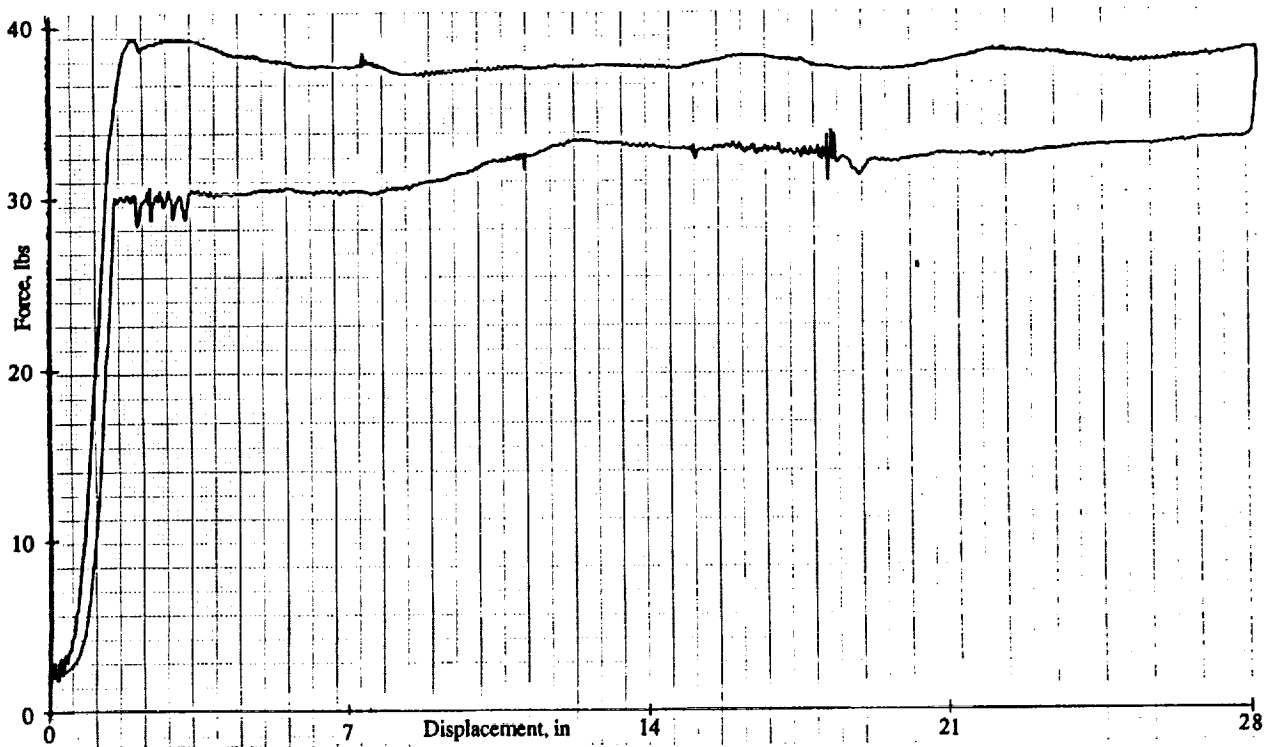

Figure 5: Force vs. Displacement Plot Over Full 28 in. Tension Mechanism Stroke