

54-02
11979

*HSR High Lift Research
Ames Research Center*

HSR High Lift Research Program

Status & Plans

*Jim Rose
Fixed Wing Aerodynamics Branch*

High Speed Research Workshop May 16, 1991

*HSR High Lift Research
Ames Research Center*

- Ames participants
- Objective and approach
- Current status
- Research plans

High Speed Research Workshop May 16, 1991

*HSR High Lift Research
Ames Research Center*

Ames Participants

- Fixed Wing Aerodynamics Branch (FFF)
 - NFAC
 - 7- x 10-Foot Wind Tunnel
 - Applied CFD

- Applied Aerodynamics Branch (RAA)
 - Applied CFD
 - 12 Foot Wind Tunnel

- Applied Computational Fluids Branch (RFA)
 - Computational tools
 - Applied CFD

High Speed Research Workshop May 16, 1991

Benefits of Improved High Lift Performance

- Reduced Noise
 - Increased rate of climb
 - Reduced thrust required
 - Increased utilization
(avoid curfew restraints)
- Reduced Weight
 - Shorter landing gear
 - Smaller/lighter wing
- Improved control/performance
 - Reduced horizontal tail size
 - Lower cruise drag
- Lower cost
 - Reduced complexity
 - Lower maintenance/down time

*HSR High Lift Research
Ames Research Center*

Objectives

- Evaluate & develop advanced concepts
- Validate design/analysis methods

High-lift systems that contribute to meeting
FAR Stage III noise abatement rules

High Speed Research Workshop May 16, 1991

*HSR High Lift Research
Ames Research Center*

Approach

CFD Techniques and Analysis:

- Potential flow
- Concept development
- Euler
- Design
- Concept development
- Navier-Stokes
- Analysis
- Concept development
- Rn effects

Wind Tunnel Experiments:

- 7x10 W.T.
- Flow physics & understanding
- 40x80x120 W.T.
- Concept evaluation & development
- Scale effects
- Integrated aerodynamics, acoustics,
& propulsion
- High fidelity experiments
- 12 Foot High-Re W.T.
- Rn effects
- Mach number effects

*HSR High Lift Research
Ames Research Center*

Advanced High-Lift Concept

Trapped vortex to provide high lift at low α

High Speed Research Workshop May 16, 1991

Current Status

- Identified trapped vortex as promising technology
- Parametric studies using CFD tools
- Preliminary W.T studies with Boeing on simple systems
- Tests in preparation for 7 x 10 in summer '91
- Continuing CFD work to Euler & N-S computations of realistic configurations

Experimental Results to Date

- 2-D water channel experiments are encouraging
- Several 2-D wind tunnel experiments have shown similar results
- Tests of single fence configurations on Boeing low-speed model showed only small lift and pitching moment benefits

Two-fence configuration should increase performance

Tests Planned in FY '91

- Basic Research Test 7/91
 - Ames 7x10 W.T.
 - Examine effects of sweep and fence geometry
- Boeing HSCT test 8/91
 - Ames 7x10 W.T.
 - Two-fence configurations based on above results

*HSR High Lift Research
Ames Research Center*

Basic Research Test

7 x 10 Foot Wind Tunnel

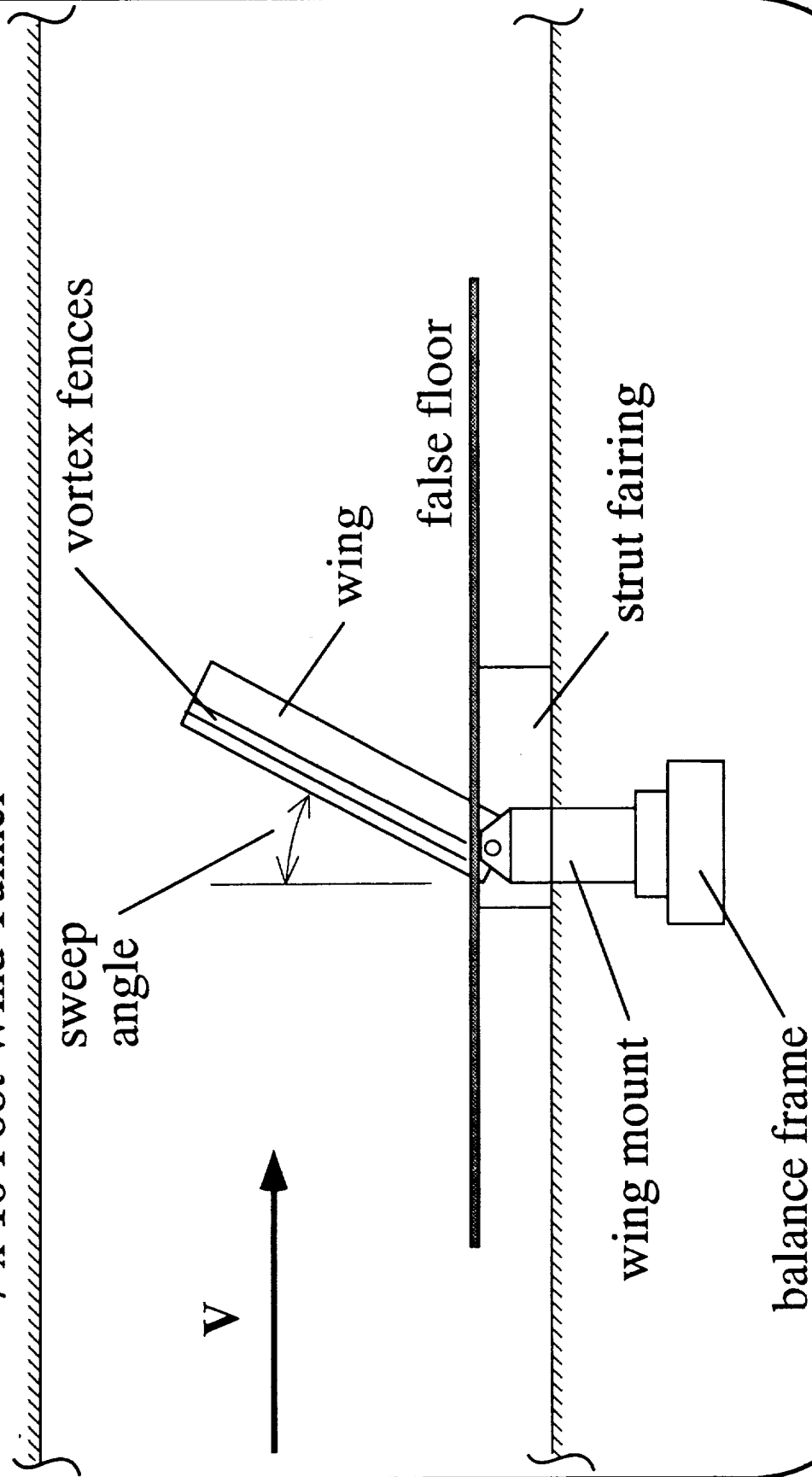

High Speed Research Workshop May 16, 1991

*HSR High Lift Research
Ames Research Center*

Application to HSCT Configuration

Two fence system on
Boeing HSCT geometry

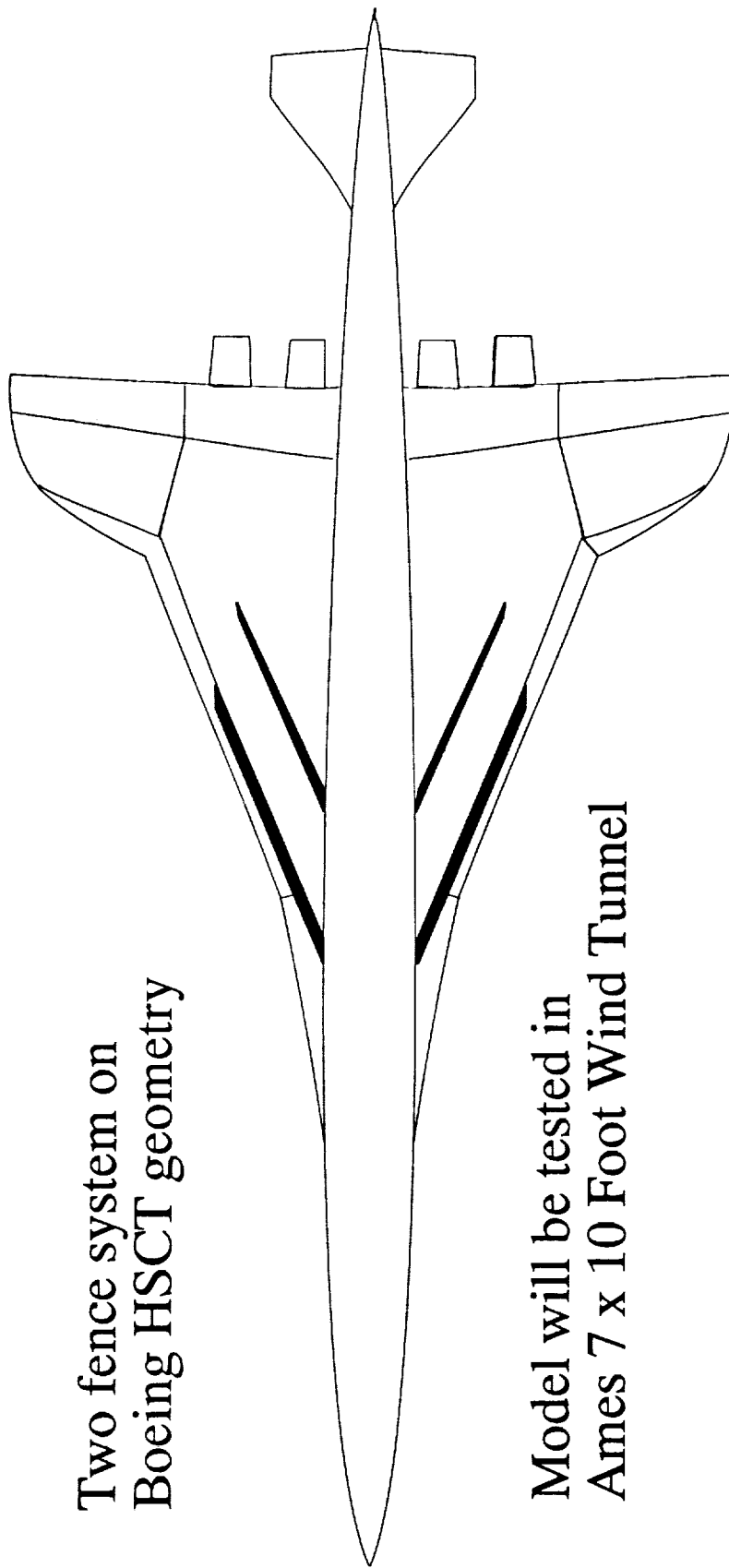

Model will be tested in
Ames 7 x 10 Foot Wind Tunnel

High Speed Research Workshop May 16, 1991

Applied CFD

Objective:

To use and improve computational methods for evaluation and development of high-lift systems for HSCT configurations

Approach:

Use codes appropriate to level of development

- Potential flow
- Euler
- Navier-Stokes

Potential Flow Analysis

Trapped Vortex Stability Analyses

- Mapping technique
- Compute stable point for vortex
- Determine suction requirements
- Parametric fence geometry variations

Euler Method

- Unstructured Grid Code (TIGER)
 - Cell refinement capability
 - * Delta wing generic fighter (vortex tracking)
 - * ONERA M-6 wing (shock refinement)
 - Deflected flap analysis capability
 - * Straight wing with adjacent leading edge flaps
- Plans
 - Trapped vortex configurations (model small-scale tests)
 - SCAT-15 model

Navier-Stokes

- Incompressible N.S.
 - INS2D code validated for trapped vortex
 - * Backward facing step
 - * Single and double fence on plate
 - Initial 3-D results obtained for double fence case
- Plans
 - Examine R_n effects
 - Model small-scale experiments
 - Realistic HSCT wing geometry

Additional Research Opportunities

- Trapped vortex performance on SCAT-15 model (LaRC 14 x 22 test)
- Trapped vortex on E-7 model (40 x 80)
- Examine leading edge radius effects, drooped leading edge, & Krueger flap on E-7 model (cooperative studies with LaRC, Boeing and DAC in 40 x 80)
- LaRC vortex flap on E-7 model (40 x 80)

Summary

- Have identified trapped vortex as a candidate high-lift technology
- Preliminary analyses and experiments are promising
- Extension of analysis to 3-D is underway
- Two 3-D wind-tunnel experiments are in preparation and scheduled to begin in July