

# Thin-Ribbon Tapered Coupler for Dielectric Waveguides

C. Yeh<sup>1</sup>

T. Y. Otoshi

Ground Antennas and Facilities Engineering Section

F. I. Shimabukuro

Aerospace Corporation

Los Angeles, California

*A recent discovery shows that a high-dielectric constant, low-loss, solid material can be made into a ribbon-like waveguide structure to yield an attenuation constant of less than 0.02 dB/m for single-mode guidance of millimeter/submillimeter waves. One of the crucial components that must be invented in order to guarantee the low-loss utilization of this dielectric-waveguide guiding system is the excitation coupler. The traditional tapered-to-a-point coupler for a dielectric rod waveguide fails when the dielectric constant of the dielectric waveguide is large. This article presents a new way to design a low-loss coupler for a high- or low-dielectric constant dielectric waveguide for millimeter or submillimeter waves.*

## I. Introduction

A recent discovery shows that a high-dielectric constant, low-loss, solid material, such as TiO ( $\epsilon_1/\epsilon_0 = 100$ ,  $\tan \delta = 0.00025$ ) or Rexolite ( $\epsilon_1/\epsilon_0 = 2.55$ ,  $\tan \delta = 0.001$ ), can be made into a ribbon-like waveguide structure to yield an attenuation constant of less than 0.02 dB/m for single-mode guidance of millimeter or submillimeter waves [1]. This discovery provides the impetus to perfect a practical low-loss guided transmission system for these short wavelengths. As a comparison of loss, the attenuation constant

of a WR28 copper waveguide is 0.58 dB/m at 32 GHz. One of the crucial components that must be invented in order to guarantee the low-loss utilization of this dielectric-waveguide guiding system is the excitation coupler.

A conventional technique to minimize the coupling loss of an excitation coupler is to taper the coupling end of a dielectric waveguide to a very narrow, sharp apex [2]. However, this method fails when the relative dielectric constant of the dielectric waveguide is much greater than unity, the free-space value. Another technique is to shape the coupling end of the dielectric waveguide into a cusp-like form [3]. This cusp design, which is based on the direct ap-

<sup>1</sup> Independent consultant to the Ground Antennas and Facilities Engineering Section.

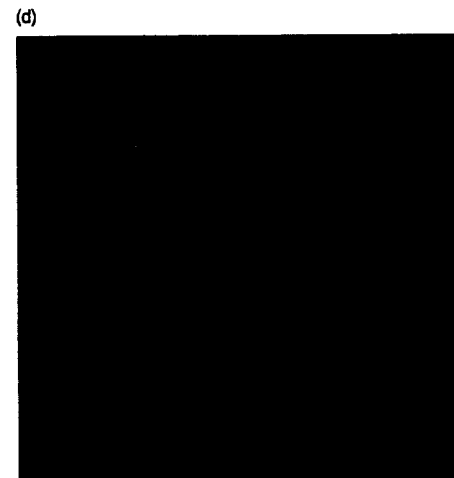
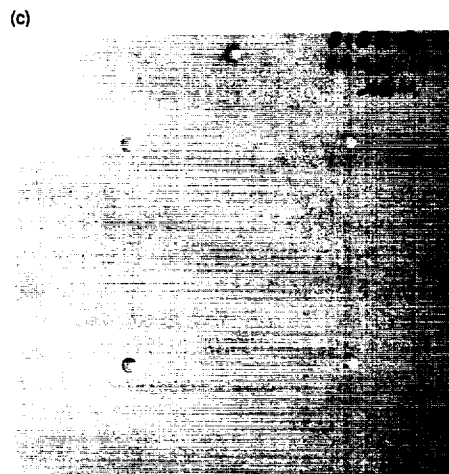
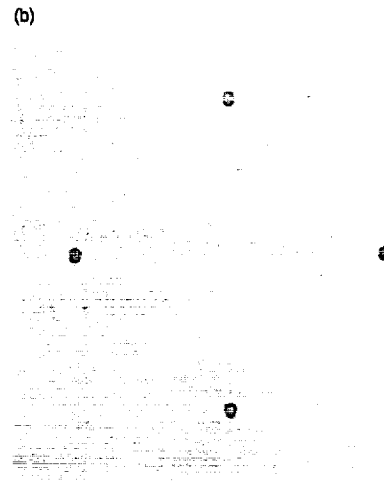
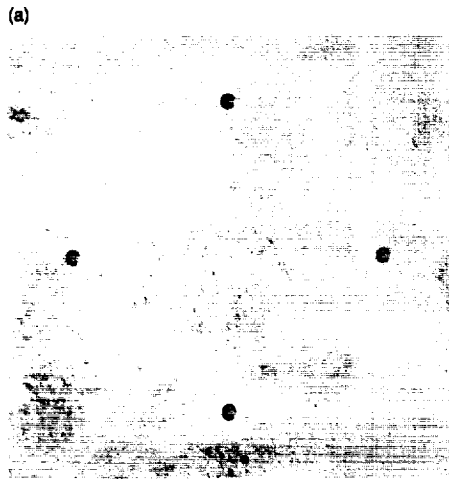

**Fig. 3. Other sample candidate shroud materials tested (10.16 cm x 10.16 cm): (a) type 1018 steel bare metal; (b) aluminum 6061; (c) aluminum 6061 with irridite surface treatment; and (d) aluminum 6061 with black anodized surface treatment.**

plication of geometrical optics to minimize reflection, is applicable to guided wave structures whose cross-sectional dimensions are many free-space wavelengths.

Neither of the two techniques described above is applicable to the case of a dielectric waveguide with (1) a large dielectric constant difference between the core and cladding material and (2) a guide dimension of less than the free-space wavelength, such as the ultralow-loss millimeter or submillimeter dielectric ribbon waveguide [1]. This article will describe a different approach for designing a low-loss coupler for this case.

## II. Approaches

### A. Impedance Matching Approach

It is possible to define a wave impedance for a given propagating mode along a dielectric waveguide of a given cross section [4]. The wave impedance may be viewed as the characteristic impedance of a transmission line (i.e., the dielectric waveguide). Thus, a tapered (tapered in the direction of propagation of the guided wave, the  $z$ -direction) dielectric waveguide is then viewed as an inhomogeneous transmission line with  $z$ -dependent characteristic impedance [5].

The problem of designing a transition between a dielectric waveguide and free space becomes one of impedance matching the characteristic impedance of a given dielectric waveguide mode to the characteristic impedance (377 ohms) of free space. It is known that, between two transmission lines with different characteristic impedances, the best matching can be achieved over a broad-band of frequencies with a tapered section of transmission line [6,7]. For this reason, in practice, transitions between a dielectric waveguide and free space are generally of the tapered-transmission line type. The shape of the taper is based upon one that produces the minimum mismatch losses over the frequency band of interest.

In principle, this tapering approach to a narrowed, thin apex is workable for any dielectric waveguide with any dielectric constant. In practice, however, this approach is workable only for a dielectric waveguide with a relative dielectric constant near unity. This is because when the core dielectric constant is large, to achieve good matching with free space, the tapered section must be very, very long and the cross-sectional dimension of the taper must be very small, making the tapered section extremely difficult to handle and align. The stability of the modal field in adhering to the tapered guiding section also becomes questionable. In other words, it is difficult to excite a guided

wave along this type of tapered section for a high-dielectric constant guide, even though good impedance matching is present. It appears that the surface area for this high-dielectric constant tapered section is too small to capture the incident wave and to transform it to a guided wave [1].

### B. Ribbon Transition Approach

Instead of tapering a high-dielectric constant guide to a very small cross-sectional area, the guide should be flattened to a large surface area and very thin thickness [1], i.e., the transition region should be tapered to a thin, flat, but wide ribbon, as shown in Fig. 1. To provide further improvements in matching, the end of the transition region can be further extended with a comb-like structure, as shown in Fig. 2. Because of the large surface area of this structure, it can be easily supported mechanically without causing noticeable interference to the electromagnetic field. The large surface area also enables the guided surface wave to better attach to the guiding structure, thus improving the launching efficiency [1].

It can be seen from Fig. 2 that this ribbon transition region is very different from the conventional tapered-to-a-point transition region used by all earlier investigators to obtain a better match between the free-space region and the dielectric waveguide region.

## III. Transitions

The analytical foundation for the transitions described in this section is given in the Appendix.

### A. Metallic Rectangular Waveguide-to-Ribbon Dielectric Waveguide Transition

The ribbon transition is tailor-made for the ultralow-loss ribbon dielectric waveguide for millimeter or submillimeter wavelengths. Figure 3 shows the transition region between a metallic rectangular waveguide supporting the dominant  $TE_{10}$  mode and a dielectric ribbon waveguide supporting the dominant  ${}_{\epsilon}HE_{11}$  mode [1]. A flared metallic horn is used to provide the wide width for the ribbon transition region.

### B. Microstripline-to-Ribbon Dielectric Waveguide Transition

Another important, practical transition is between the microstripline [8] and the ribbon dielectric waveguide. Figure 4 is a sketch of such a transition. In order to minimize Fresnel-type reflection losses and to accommodate the wide width of the ribbon transition, an additional transition section is added as shown. In the added transition region, it

is necessary to taper the microstripline dielectric filling to a vanishingly thin wedge while the upper conducting strip is flared to a wide width. It is seen that the field concentrated under the narrow, upper conducting strip of the microstripline is spread out through the added transition region to cover the wider width of the ribbon transition.

### C. Transition for a Round Dielectric Waveguide

If it is desirable to excite propagating fields on a round (circular) dielectric waveguide, the transition region, as shown in Fig. 5, can be designed. Here, the circular core is flared in one transverse direction and compressed in the other transverse direction into a flat ribbon and then tapered to a very narrow wedge. Again, the idea is to re-

tain the largest possible surface area to capture the guided fields. Thus, an incident plane wave can easily be captured smoothly by the wide-but-thin wedge-shaped dielectric transition.

## IV. Conclusions

A semiheuristic way to design a low-loss excitation coupler for a high-dielectric constant dielectric waveguide has been presented. Unlike the traditional tapered-to-a-point transition region, a tapered-to-a-thin-sheet transition region is proposed. It is found that the thin sheet gives better stability for the surface wave in the transition region, thus improving the launching efficiency for the wave onto a dielectric waveguide.

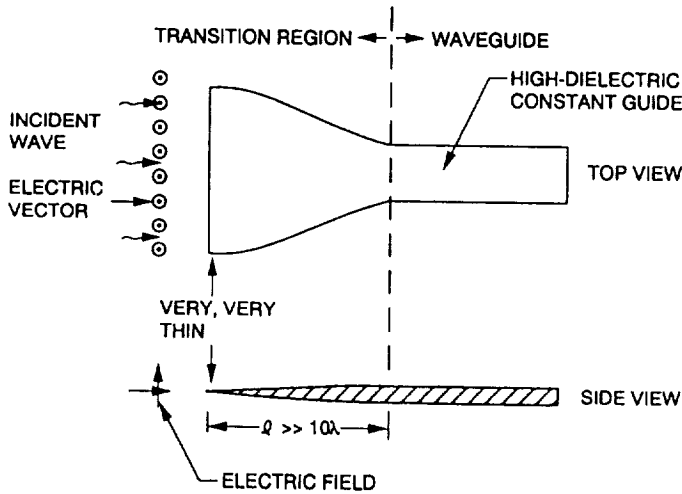

Fig. 1. Tapered section for a high-dielectric constant waveguide.

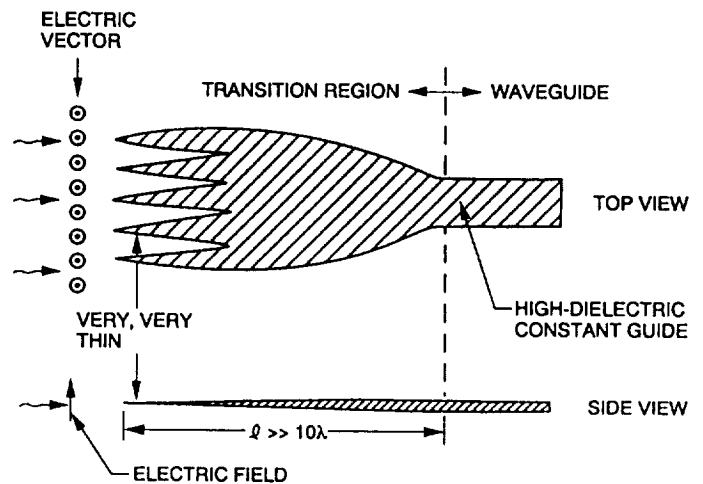

Fig. 2. Comb-like transition region.

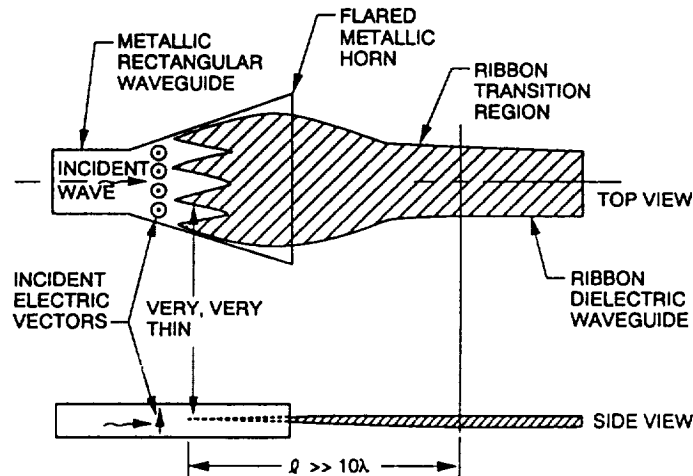

Fig. 3. Metallic rectangular waveguide-to-ribbon dielectric waveguide transition.

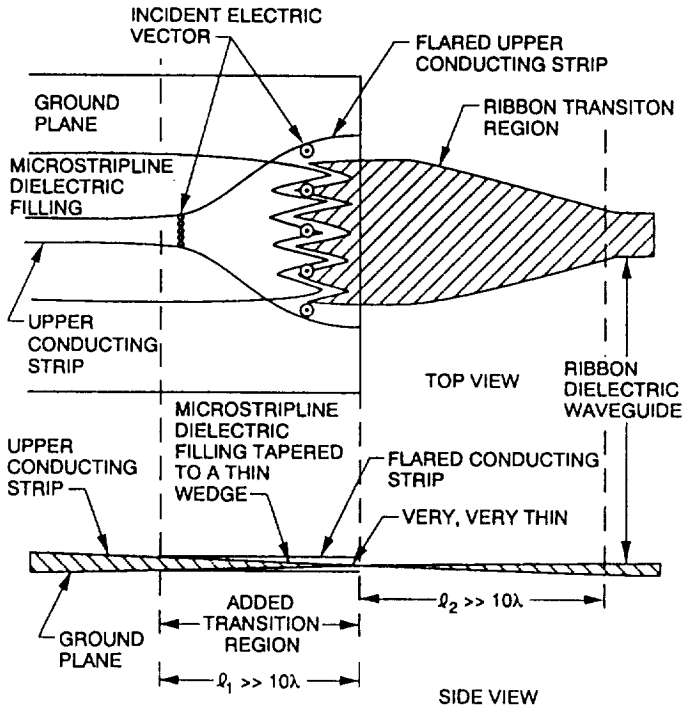

Fig. 4. Microstripline-to-ribbon dielectric waveguide transition.

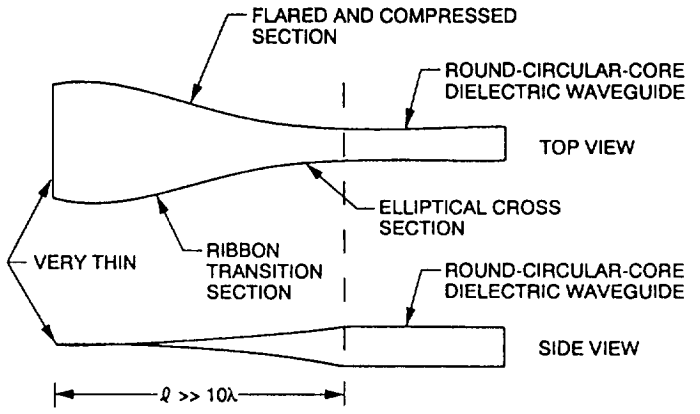

Fig. 5. Transition from a ribbon-wedge to a round-circular-core dielectric waveguide.

## Appendix

### Analytical Foundation

The following provides the theoretical foundation [9,10] for the heuristic approach to the design of low-loss, efficient transitions to dielectric waveguides. The canonical problem is the study of the propagation characteristics of a guided wave on a dielectric slab of thickness  $d$ , enclosed by two conducting plates as shown in Fig. A-1. Referring to Fig. A-1, it is of interest to learn how a guided wave is detached from the conducting planes as  $a$  (the separation of the two conducting plates) is increased. We wish to know how the guided field and its wave impedance of a parallel plate guide are affected by the presence of a very thin high-dielectric constant slab.

The guided mode of interest is the one whose electric field is polarized in the x-direction and whose electric field distribution is even with respect to positive and negative values of  $x$ . A propagation factor and a time-dependent factor of  $e^{-j\beta z + j\omega t}$ , where  $\beta$  is the propagation constant and  $\omega$  is the frequency of the wave, is implied and suppressed for all field components. In region (1), the field components for the mode of interest are

$$E_z^{(1)} = A_1 \sin \sqrt{k_1^2 - \beta^2} x \quad (\text{A-1})$$

$$E_x^{(1)} = \frac{-j\beta A_1}{\sqrt{k_1^2 - \beta^2}} \cos \sqrt{k_1^2 - \beta^2} x \quad (\text{A-2})$$

$$H_y^{(1)} = \frac{-j\omega\epsilon_1 A_1}{\sqrt{k_1^2 - \beta^2}} \cos \sqrt{k_1^2 - \beta^2} x \quad (\text{A-3})$$

where  $A_1$  is an arbitrary constant and  $k_1^2 = \omega^2\mu_0\epsilon_1$ . In region (0), the field components are

$$E_z^{(0)} = A_0 \sin \left[ \sqrt{k_0^2 - \beta^2} \left( x - \frac{a}{2} \right) \right]$$

$$\text{for } \beta < k_0 \quad (\text{A-4a})$$

$$= A_0 \sinh \left[ \sqrt{\beta^2 - k_0^2} \left( x - \frac{a}{2} \right) \right]$$

$$\text{for } \beta > k_0 \quad (\text{A-4b})$$

$$E_x^{(0)} = \frac{-j\beta A_0}{\sqrt{k_0^2 - \beta^2}} \cos \left[ \sqrt{k_0^2 - \beta^2} \left( x - \frac{a}{2} \right) \right]$$

$$\text{for } \beta < k_0 \quad (\text{A-5a})$$

$$= \frac{-\beta A_0}{\sqrt{k_0^2 - \beta^2}} \cosh \left[ \sqrt{\beta^2 - k_0^2} \left( x - \frac{a}{2} \right) \right]$$

$$\text{for } \beta > k_0 \quad (\text{A-5b})$$

$$H_y^{(0)} = \frac{-j\omega\epsilon_0 A_0}{\sqrt{k_0^2 - \beta^2}} \cos \left[ \sqrt{k_0^2 - \beta^2} \left( x - \frac{a}{2} \right) \right]$$

$$\text{for } \beta < k_0 \quad (\text{A-6a})$$

$$= \frac{-\omega\epsilon_0 A_0}{\sqrt{k_0^2 - \beta^2}} \cosh \left[ \sqrt{\beta^2 - k_0^2} \left( x - \frac{a}{2} \right) \right]$$

$$\text{for } \beta > k_0 \quad (\text{A-6b})$$

where  $A_0$  is an arbitrary constant and  $k_0^2 = \omega^2\mu_0\epsilon_0$ . Matching the boundary conditions at  $x = d/2$  and solving for the nontrivial solution yields the dispersion relation

$$\frac{\epsilon_0 \sqrt{k_1^2 - \beta^2}}{\epsilon_1 \sqrt{k_0^2 - \beta^2}} \tan \left[ \sqrt{k_1^2 - \beta^2} \frac{d}{2} \right] =$$

$$\tan \left[ \sqrt{k_0^2 - \beta^2} \left( \frac{d}{2} - \frac{a}{2} \right) \right]$$

$$\text{for } \beta < k_0 \quad (\text{A-7})$$

or

$$- \frac{\epsilon_0 \sqrt{k_1^2 - \beta^2}}{\epsilon_1 \sqrt{\beta^2 - k_0^2}} \tan \left[ \sqrt{k_1^2 - \beta^2} \frac{d}{2} \right] =$$

$$\tanh \left[ \sqrt{\beta^2 - k_0^2} \left( \frac{d}{2} - \frac{a}{2} \right) \right] \text{ for } (k_1 > \beta > k_0) \quad (\text{A-8})$$

It is seen that, if  $d \ll a$  and if  $\beta < k_0$ , the fields inside the conducting plates are basically those of a parallel-plate conducting waveguide whose propagation constant is given by

$$\left(\frac{\beta a}{2}\right) \simeq \sqrt{\left(k_0 \frac{a}{2}\right)^2 - \pi^2} \quad (\text{A-9})$$

with a phase velocity,  $\omega/\beta$ , faster than the speed of light in a vacuum. As  $k_0 a$  becomes large and  $\beta > k_0$ , the fields are basically governed by the fields on a slab dielectric waveguide with a phase velocity slower than the speed of light in a vacuum. A sketch of the transformation (or launching) of the transverse electric field for the dominant mode from an enclosed waveguide to a dielectric ribbon guide through a wedge dielectric flared-horn transition region (which slows down the phase velocity of the wave) is shown in Fig. A-2. It is seen that the  $TM_1$  mode in a conducting parallel-plate waveguide can be launched smoothly onto a flat ribbon waveguide as the dominant  $TM_0$  mode if the transition region contains a gradually tapered section of the dielectric ribbon and a gradually flared conducting-plates region. Due to the thinness and wideness of the tapered dielectric ribbon, this type of transition remains effective even when the dielectric constant of the ribbon is very large.

Let us consider this transition from the impedance matching point of view. The wave impedance of the  $TM_1$  mode in the parallel-plate waveguide is [11]

$${}_p Z_{TM_1} = \frac{\beta^{(TM_1)}}{\omega \epsilon_0} \quad (\text{A-10})$$

where the subscript  $p$  means a parallel-plate guide and  $\beta^{(TM_1)}$  represents the propagation constant of the  $TM_1$  mode, expressed as

$$\beta^{(TM_1)} = \sqrt{\omega^2 \mu \epsilon_0 - \left(\frac{2\pi}{a}\right)^2} \quad (\text{A-11})$$

Using the same definition for wave impedance as the conducting guide, for a dielectric slab guide, one has

$${}_d Z_{TM_0}^{(0),(1)} = \frac{E_x^{(0),(1)}}{H_y^{(0),(1)}} = \frac{\beta^{(TM_0)}}{\omega \epsilon_{0,1}} \quad (\text{A-12})$$

where the subscript  $d$  means a dielectric slab (ribbon) waveguide and the subscript  $TM_0$  means the dominant mode on the dielectric slab guide;  $E_x$  and  $H_y$  are, respectively, the transverse electric field and the transverse magnetic field of the  $TM_0$  mode; and the superscript (0) or (1) refers to the region outside the dielectric slab (the cladding region) or the region inside the dielectric slab (the core region). Unlike the case for an empty conducting waveguide, the wave impedance for a dielectric slab guide, defined as the ratio of the transverse electric field and the transverse magnetic field, depends on the region in which it applies, as shown by Eq. (A-12). In fact,

$$\frac{{}_d Z_{TM_0}^{(0)}}{{}_d Z_{TM_0}^{(1)}} = \frac{\epsilon_1}{\epsilon_0} \quad (\text{A-13})$$

This perhaps highlights the reason why the usual tapering technique, i.e., conical tapering to a thin apex, does *not* work well for high-dielectric constant dielectric waveguides. The same can be said for the tapered ribbon guide, but, because the surface area for the surface wave to “cling to” does not decrease, the surface wave can still be attached to the ribbon structure, even when the thickness of the ribbon is very small and when the dielectric constant of the ribbon is high. Another way to look at this problem is that, since most of the guided energy of a thin-ribbon electric waveguide is outside the dielectric material, the wave impedance of the dielectric ribbon can be approximately represented by the “outside” wave impedance, i.e.,  ${}_d Z_{TM_0}^{(0)} = \beta^{(TM_0)}/\omega \epsilon_0$ , which is very close to the wave impedance of the empty parallel-plate waveguide, i.e.,  ${}_p Z_{TM_1} = \beta^{(TM_1)}/\omega \epsilon_0$ , implying good impedance matching or good launching of the  $TM_1$  wave from the parallel-plate guide to the  $TM_0$  mode of the thin-ribbon dielectric waveguide.

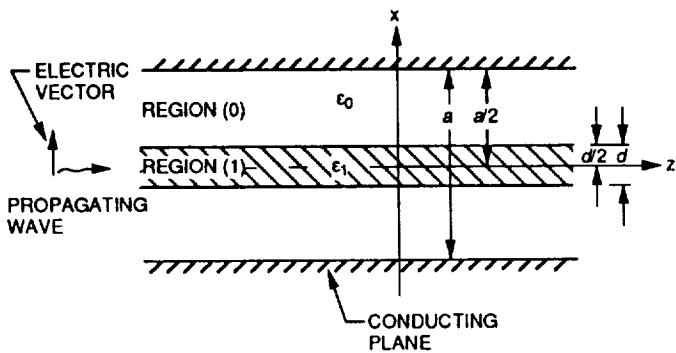

Fig. A-1. Geometry of the canonical problem.

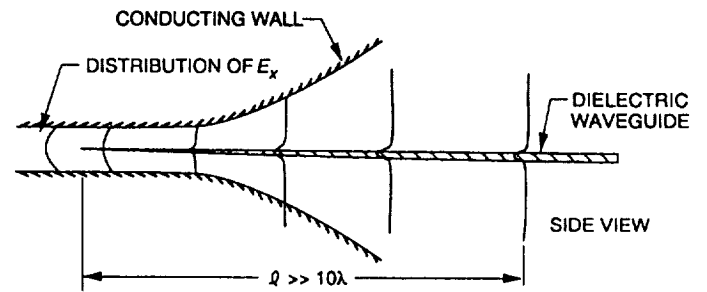

Fig. A-2. Transverse electric field transition from an enclosed guide to an open dielectric ribbon guide.

## References

- [1] C. Yeh, F. I. Shimabukuro, and J. Chu, "Dielectric Ribbon Waveguide: an Optimum Configuration for Ultra-Low-Loss Millimeter/Submillimeter Dielectric Waveguide," *IEEE Transactions on Microwave Theory Technology*, vol. 38, no. 6, pp. 691-702, June 1990.
- [2] T. N. Trinh, J. A. G. Malberbe, and R. Mittra, "A Metal-to-Dielectric Waveguide Transition with Application to Millimeter-Wave Integrated Circuits," *1980 IEEE-MTT-S International Microwave Symposium*, Washington, DC, pp. 205-207, May 1980.
- [3] H. M. Presby and C. A. Edwards, "Near 100% Efficiency Fibre Microlenses," *Electronic Letters*, vol. 28, no. 6, pp. 582-584, March 12, 1992.
- [4] C. Yeh, "Elliptical Dielectric Waveguides," Ph.D. thesis, California Institute of Technology, Pasadena, California, 1962, and *Journal of Applied Physics*, vol. 33, no. 11, pp. 3235-3243, November 1962.
- [5] A. Ishimaru, *Electromagnetic Wave Propagation, Radiation, and Scattering*, Englewood Cliffs, New Jersey: Prentice Hall, 1991.
- [6] R. E. Collin, *Foundations for Microwave Engineering*, New York: McGraw-Hill, pp. 237-254, 1966.
- [7] M. Jamil Ahmed, "Impedance Transformation Equations for Exponential, Cosine-Squared, and Parabolic Tapered Transmission Lines," *IEEE Transactions on Microwave Theory and Techniques*, vol. MTT-29, no. 1, pp. 67-68, January 1981.
- [8] K. C. Gupta, R. G. Garg, and I. J. Bahl, *Microstrip Lines and Slotted Lines*, Dedham, Massachusetts: Artech House Books, 1982.
- [9] R. E. Collin, *Field Theory of Guided Waves*, New York: McGraw-Hill, 1960.
- [10] S. Ramo, J. R. Whinnery, and T. Van Duzer, *Fields and Waves in Communication Electronics*, 2nd ed., New York: Wiley, 1984.
- [11] F. E. Borginis and C. H. Papas, "Electromagnetic Waveguides and Resonators," *Handbuch der Physik*, vol. XVI, Berlin, Germany: Springer Verlag, pp. 285-423, 1958.